



**THE DATASHEET OF
13007DFP**





ST13007DFP

HIGH VOLTAGE FAST-SWITCHING NPN POWER TRANSISTOR

- IMPROVED SPECIFICATION:
 - LOWER LEAKAGE CURRENT
 - TIGHTER GAIN RANGE
 - DC CURRENT GAIN PRESELECTION
 - TIGHTER STORAGE TIME RANGE
- HIGH VOLTAGE CAPABILITY
- INTEGRATED FREE-WHEELING DIODE
- LOW SPREAD OF DYNAMIC PARAMETERS
- MINIMUM LOT-TO-LOT SPREAD FOR RELIABLE OPERATION
- VERY HIGH SWITCHING SPEED
- FULLY CHARACTERIZED AT 125 °C
- LARGE RBSOA
- FULLY INSULATED PACKAGE (U.L. COMPLIANT) FOR EASY MOUNTING

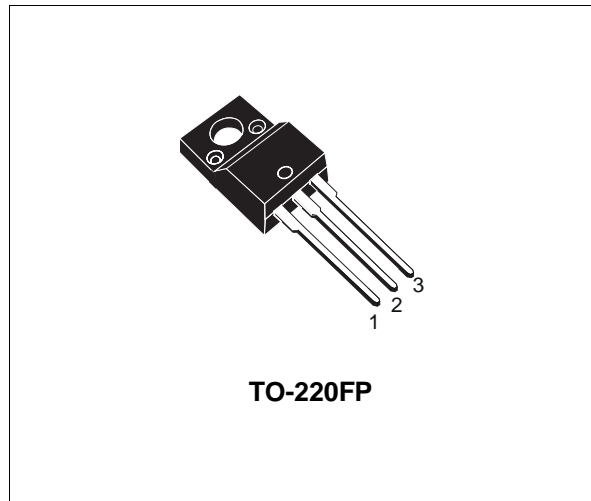

APPLICATIONS

- UP TO 120W ELECTRONIC TRANSFORMERS FOR HALOGEN LAMPS
- SWITCH MODE POWER SUPPLIES

DESCRIPTION

The device is manufactured using high voltage Multi Epitaxial Planar technology for high switching speeds and high voltage capability. It uses a Cellular Emitter structure to enhance switching speeds.

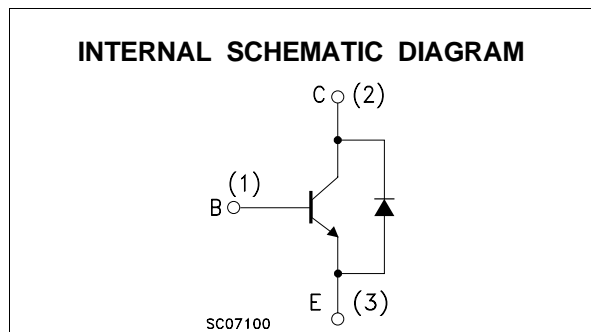

ABSOLUTE MAXIMUM RATINGS

Symbol	Parameter	Value	Unit
V_{CEV}	Collector-Emitter Voltage ($V_{BE} = -1.5V$)	700	V
V_{CEO}	Collector-Emitter Voltage ($I_B = 0$)	400	V
V_{EBO}	Emitter-Base Voltage ($I_C = 0$)	9	V
I_C	Collector Current	8	A
I_{CM}	Collector Peak Current	16	A
I_B	Base Current	4	A
I_{BM}	Base Peak Current	8	A
P_{tot}	Total Dissipation at $T_c \leq 25^\circ C$	36	W
V_{isol}	Insulation Withstand Voltage (RMS) from All Three Leads to External Heatsink	1500	V
T_{stg}	Storage Temperature	-65 to 150	°C
T_j	Max. Operating Junction Temperature	150	°C

THERMAL DATA

R _{thj-case}	Thermal Resistance Junction-case	Max	3.47	°C/W
R _{thj-amb}	Thermal Resistance Junction-ambient	Max	62.5	°C/W

ELECTRICAL CHARACTERISTICS (T_{case} = 25 °C unless otherwise specified)

Symbol	Parameter	Test Conditions	Min.	Typ.	Max.	Unit
I _{CEs}	Collector Cut-off Current (V _{BE} = 0)	V _{CE} = 700 V V _{CE} = 700 V T _c = 100 °C			10 0.5	μA mA
I _{CEO}	Collector Cut-off Current (I _B = 0)	V _{CE} = 400 V			100	μA
I _{EBO}	Emitter Cut-off Current (I _C = 0)	V _{EB} = 9 V			100	μA
V _{CEO(sus)*}	Collector-Emitter Sustaining Voltage (I _B = 0)	I _C = 10 mA	400			V
V _{CE(sat)*}	Collector-Emitter Saturation Voltage	I _C = 2 A I _B = 0.4 A I _C = 5 A I _B = 1 A I _C = 8 A I _B = 2 A I _C = 5 A I _B = 1 A T _c = 100 °C			0.8 1.5 2 3	V V V V
V _{BE(sat)*}	Base-Emitter Saturation Voltage	I _C = 2 A I _B = 0.4 A I _C = 5 A I _B = 1 A I _C = 5 A I _B = 1 A T _c = 100 °C			1.2 1.6 1.5	V V V
h _{FE*}	DC Current Gain	I _C = 2 A V _{CE} = 5 V I _C = 5 A V _{CE} = 5 V	18 8		40 25	
V _f	Diode Forward Voltage	I _C = 3 A			2.5	V
t _s t _f	INDUCTIVE LOAD Storage Time Fall Time	I _C = 5 A V _{CL} = 250 V R _{BB} = 0Ω I _{B1} = 1 A V _{BE(off)} = -5 V L = 200 μH (see figure 1)		1.7 90	2.3 150	μs ns
t _s t _f	INDUCTIVE LOAD Storage Time Fall Time	I _C = 5 A V _{CL} = 250 V R _{BB} = 0Ω I _{B1} = 1 A V _{BE(off)} = -5 V L = 200 μH T _C = 125 °C (see figure 1)		2.2 150		μs ns

* Pulsed: Pulse duration = 300 μs, duty cycle 2 %.

Safe Operating Area

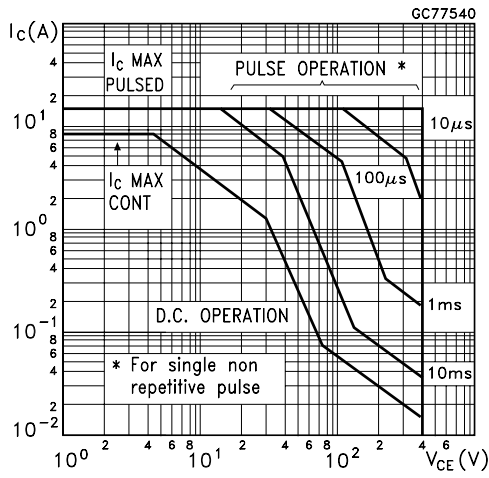

Derating Curve

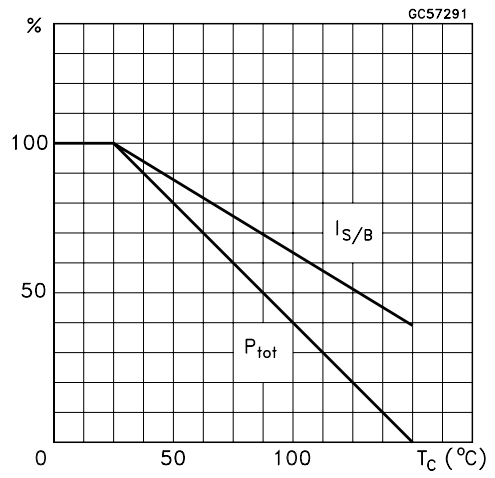

DC Current Gain

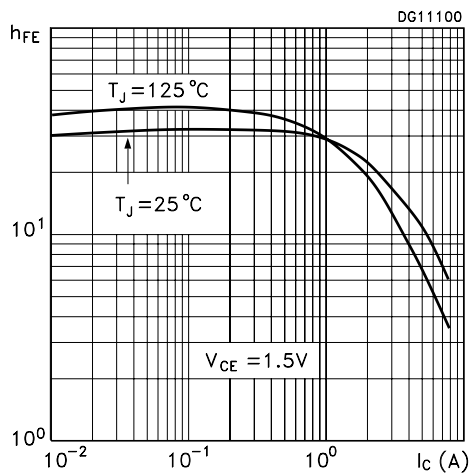

DC Current Gain

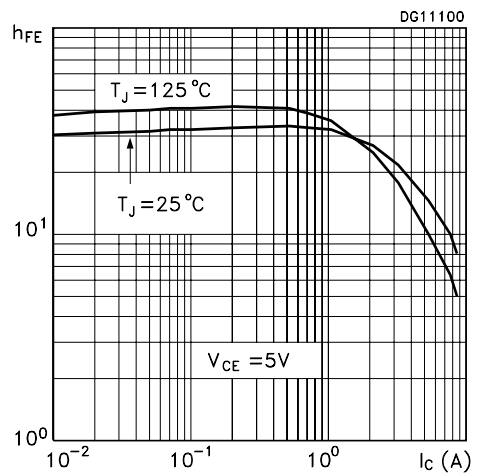

Collector Emitter Saturation Voltage

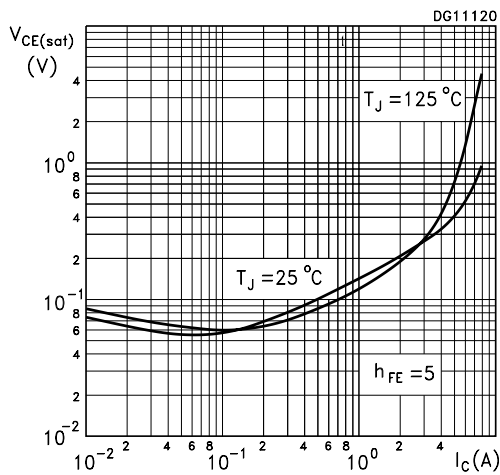

Base Emitter Saturation Voltage

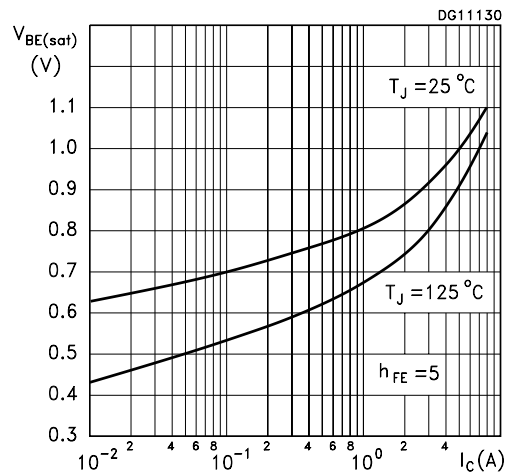

Diode Forward Voltage

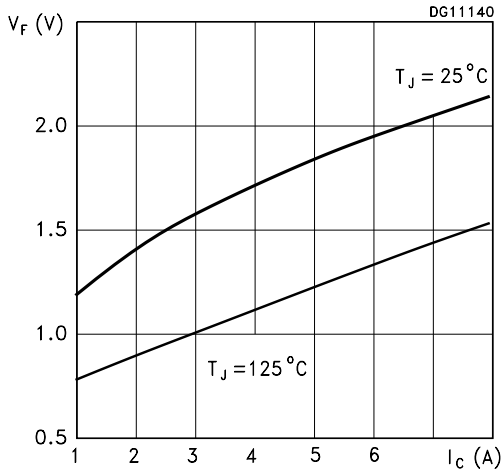

Switching Time Resistive Load

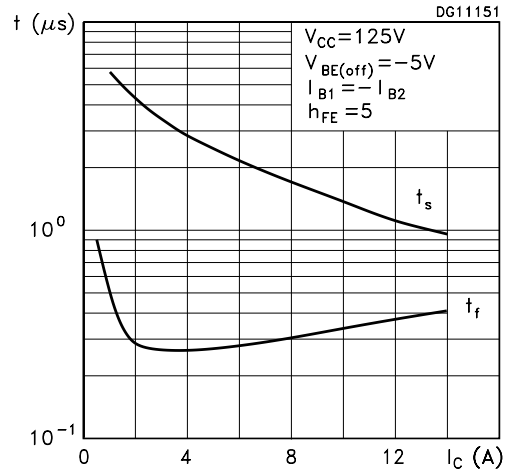

Switching Time Inductive Load

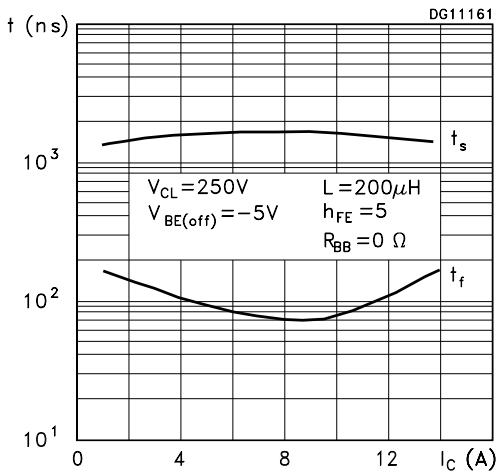

Reverse Biased SOA

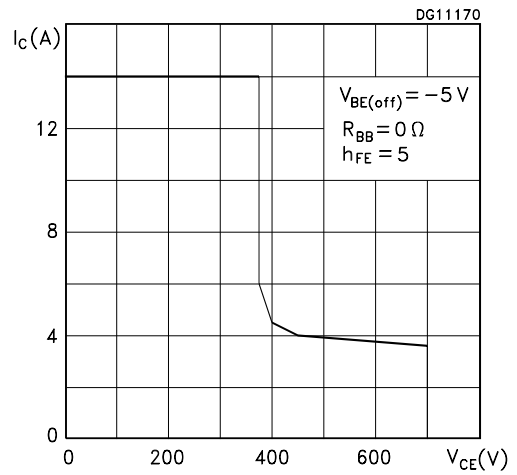

Figure 1: Inductive Load Switching Test Circuit.

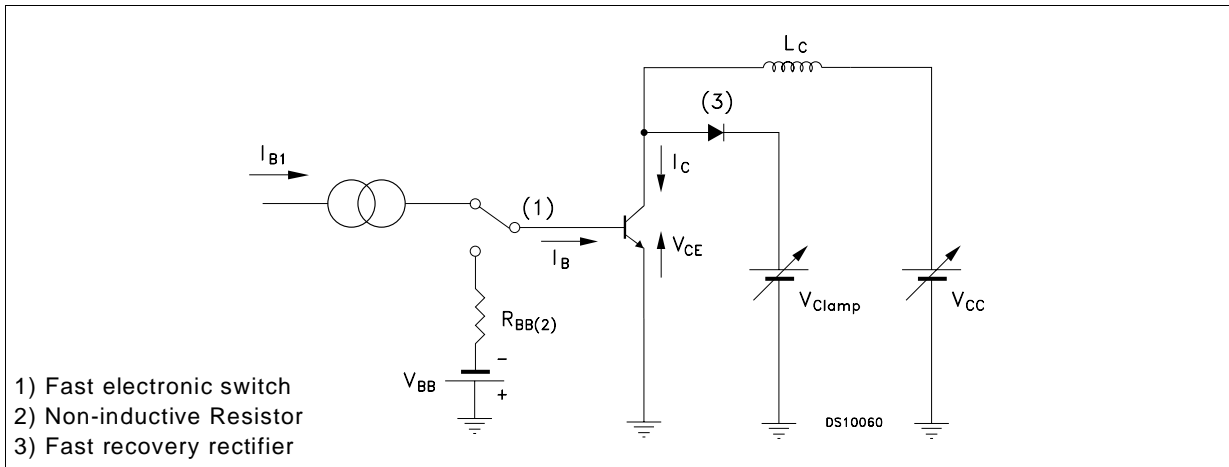
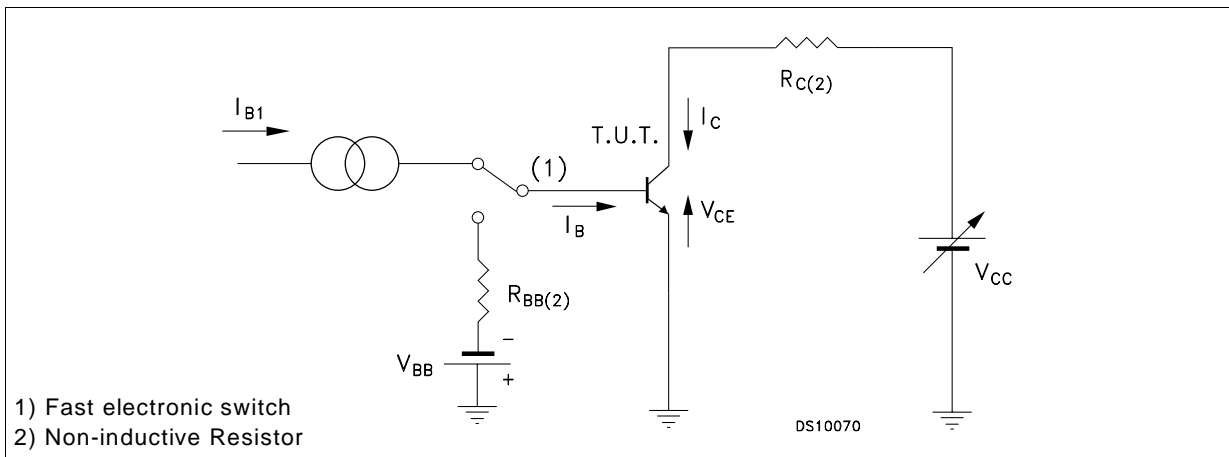
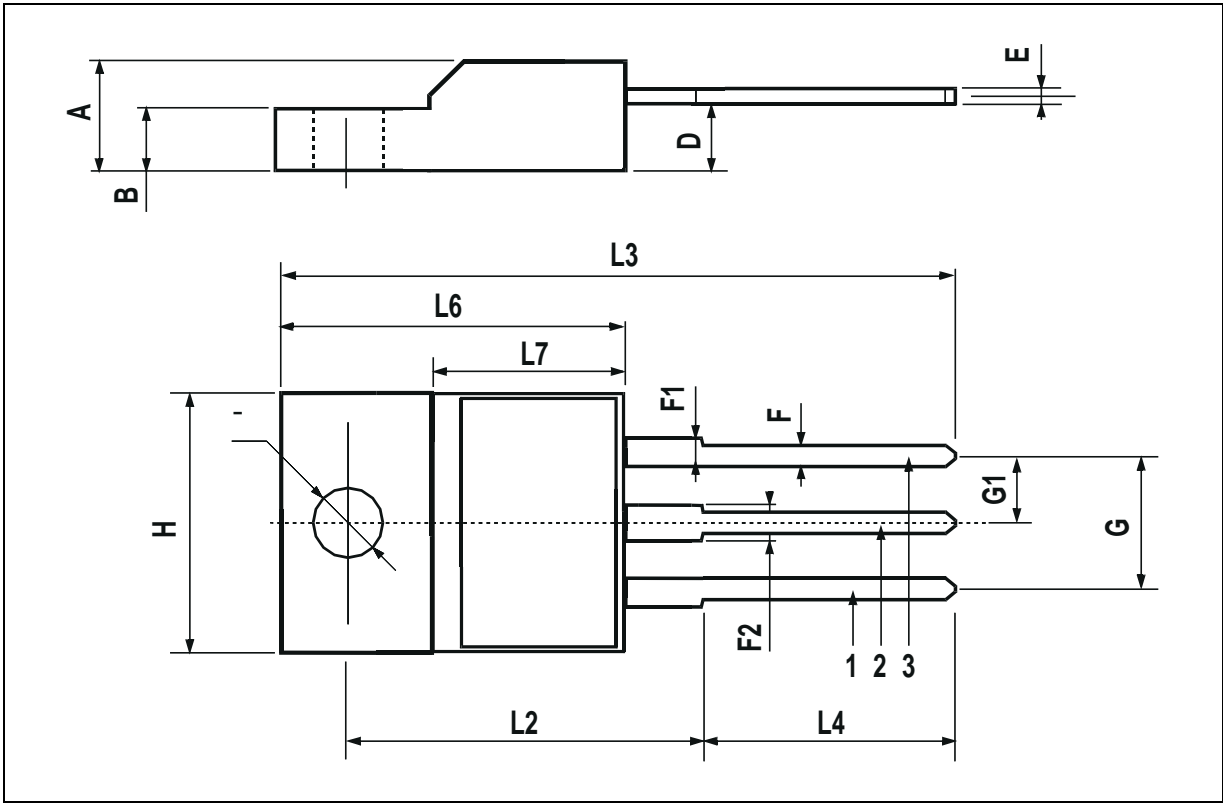

Figure 2: Resistive Load Switching Test Circuit.



TO-220FP MECHANICAL DATA

DIM.	mm			inch		
	MIN.	TYP.	MAX.	MIN.	TYP.	MAX.
A	4.4		4.6	0.173		0.181
B	2.5		2.7	0.098		0.106
D	2.5		2.75	0.098		0.108
E	0.45		0.7	0.017		0.027
F	0.75		1	0.030		0.039
F1	1.15		1.7	0.045		0.067
F2	1.15		1.7	0.045		0.067
G	4.95		5.2	0.195		0.204
G1	2.4		2.7	0.094		0.106
H	10		10.4	0.393		0.409
L2		16			0.630	
L3	28.6		30.6	1.126		1.204
L4	9.8		10.6	0.385		0.417
L6	15.9		16.4	0.626		0.645
L7	9		9.3	0.354		0.366
Ø	3		3.2	0.118		0.126



Information furnished is believed to be accurate and reliable. However, STMicroelectronics assumes no responsibility for the consequences of use of such information nor for any infringement of patents or other rights of third parties which may result from its use. No license is granted by implication or otherwise under any patent or patent rights of STMicroelectronics. Specification mentioned in this publication are subject to change without notice. This publication supersedes and replaces all information previously supplied. STMicroelectronics products are not authorized for use as critical components in life support devices or systems without express written approval of STMicroelectronics.

The ST logo is a trademark of STMicroelectronics

© 2003 STMicroelectronics – Printed in Italy – All Rights Reserved

STMicroelectronics GROUP OF COMPANIES

Australia - Brazil - Canada - China - Finland - France - Germany - Hong Kong - India - Israel - Italy - Japan - Malaysia - Malta - Morocco - Singapore - Spain - Sweden - Switzerland - United Kingdom - United States.

<http://www.st.com>

Looking for pricing, stock, or lifecycle information?

Click below to explore more details on WIN SOURCE:

 [View 13007DFP on WIN SOURCE](#)

 [STMicroelectronics](#) Information

Optimize Your Supply Chain with WIN SOURCE Solutions

-  Global Sourcing Solution
-  Obsolete Management
-  Cost Control Management
-  Shortage Management
-  Alternative Solution
-  Excess Inventory Management