



**THE DATASHEET OF  
LQH32NH100J23L**



# Reference Only

SpecNo.JELF243A-9146E-01

P1/9

## CHIP COIL (CHIP INDUCTORS) LQH32NH□□□□23L Murata Standard Reference Specification [AEC-Q200]

### 1. Scope

This reference specification applies to Wire Wound Chip Coil (Chip Inductors) LQH32NH Series for Automotive Electronics based on AEC-Q200.

### 2. Part Numbering

(ex)   LQ     H     32     N     H     1R0     M     2     3     L    
 Product ID Structure Dimension Applications Category Inductance Tolerance Features Electrode Packaging  
 (L×W) and Characteristics L:Taping

### 3. Rating

- Operating Temperature Range. -40 to +125°C
- Storage Temperature Range. -40 to +125°C

Customer's Part Number	MURATA Part Number	Inductance		Q (min.)	DC Resistance		Self Resonant Frequency (MHz min.)	Rated Current (mA)	ESD 5A : 8kV
		(μH)	Tolerance (%)		(Ω)	Tolerance (%)			
	LQH32NH1R0M23L	1.0	M:±20	25	0.06	± 20	100	780	5A
	LQH32NH1R2J23L	1.2			0.07		90	720	
	LQH32NH1R5J23L	1.5			0.08		85	675	
	LQH32NH1R8J23L	1.8			0.09		80	635	
	LQH32NH2R2J23L	2.2			0.097		75	610	
	LQH32NH2R7J23L	2.7			0.15		70	495	
	LQH32NH3R3J23L	3.3			0.20		65	425	
	LQH32NH3R9J23L	3.9			0.14		60	510	
	LQH32NH4R7J23L	4.7			0.21		55	420	
	LQH32NH5R6J23L	5.6			0.32		50	335	
	LQH32NH6R8J23L	6.8			0.36		45	315	
	LQH32NH8R2J23L	8.2			0.40		40	300	
	LQH32NH100J23L	10			0.34		35	325	
	LQH32NH120J23L	12		0.50	30	270			
	LQH32NH150J23L	15		0.50	25	235			
	LQH32NH180J23L	18		0.64		220			
	LQH32NH220J23L	22		0.74	20	190			
	LQH32NH270J23L	27	J:± 5	1.00		175			
	LQH32NH330J23L	33		1.14	40	170			
	LQH32NH390J23L	39		1.27		15	155		
	LQH32NH470J23L	47		1.46		13	130		
	LQH32NH560J23L	56		2.00		12	125		
	LQH32NH680J23L	68		2.25		11	100		
	LQH32NH820J23L	82		3.25		10	95		
	LQH32NH101J23L	100		3.65			85		
	LQH32NH121J23L	120		4.20		8.0	80		
	LQH32NH151J23L	150		4.85			6.0	60	
	LQH32NH181J23L	180		7.60		5.5		40	
	LQH32NH221J23L	220		8.45					
	LQH32NH271J23L	270		9.70	5.0	55			
	LQH32NH331J23L	330		11.0		50			
	LQH32NH391J23L	390		12.4		45			
	LQH32NH471J23L	470		14.1	4.0	40			
	LQH32NH561J23L	560		14.6					

# Reference Only

SpecNo.JELF243A-9146E-01

P2/9

## 4. Testing Conditions

《Unless otherwise specified》

Temperature : Ordinary Temperature (15 to 35°C)  
 Humidity : Ordinary Humidity (25 to 85 %(RH))

《In case of doubt》

Temperature : 20 ± 2°C  
 Humidity : 60 to 70 %(RH)  
 Atmospheric Pressure : 86 to 106 kPa

## 5. Appearance and Dimensions (No marking)

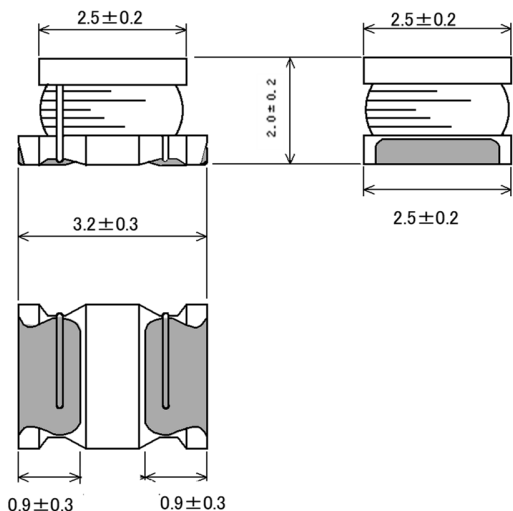

\* No Marking.

(in mm)

■ Unit Mass (Typical value)  
 0.060 g

## 6. Electrical Performance

No.	Item	Specification	Test Method
6.1	Inductance	Inductance shall meet item 3.	Measuring Equipment : KEYSIGHT 4192A or equivalent Measuring Frequency : 1MHz / 1.0 to 390μH 1kHz / 470 to 560μH
6.2	Q		Measuring Equipment : KEYSIGHT 4192A or equivalent Measuring Frequency : 1MHz / 1.0 to 82μH 796kHz / 100 to 560μH
6.2	DC Resistance	DC Resistance shall meet item 3.	Measuring Equipment : Digital multi meter
6.3	Self Resonant Frequency(S.R.F)	S.R.F shall meet item 3.	Measuring Equipment : KEYSIGHT E4991A or equivalent
6.4	Rated Current	Self temperaturer rise shall be limited to 20°C max. Inductance Change : within ± 10%	The rated current is applied.

## 7. AEC-Q200 Requirement

7.1 Performance (based on Table 5 for Magnetics(Inductors / Transformer)  
 AEC-Q200 Rev.D issued June. 1 2010

AEC-Q200			Murata Specification / Deviation				
No	Stress	Test Method					
3	High Temperature Exposure	1000hours at 125 deg C Set for 24hours at room temperature, then measured.	Meet Table A after testing. Table A <table border="1" style="margin-left: 20px;"> <tr> <td>Appearance</td> <td>No damage</td> </tr> <tr> <td>Inductance change</td> <td>Within ±5%</td> </tr> </table>	Appearance	No damage	Inductance change	Within ±5%
Appearance	No damage						
Inductance change	Within ±5%						
4	Temperature Cycling	1000cycles -40 deg C to + 125deg C Set for 24hours at room temperature, then measured.	Meet Table A after testing.				

# Reference Only

SpecNo.JELF243A-9146E-01

P3/9

AEC-Q200			Murata Specification / Deviation				
No	Stress	Test Method					
7	Biased Humidity	1000hours at 85 deg C, 85%RH unpowered..	Meet Table A after testing.				
8	Operational Life	Apply 125 deg C 1000 hours Set for 24hours at room temperature, then measured	Meet Table A after testing.				
9	External Visual	Visual inspection	No abnormalities				
10	Physical Dimension	Meet ITEM 5 (Style and Dimensions)	No defects				
12	Resistance to Solvents	Per MIL-STD-202 Method 215	Not Applicable				
13	Mechanical Shock	Per MIL-STD-202 Method 213 100g's/6ms/Half sine	Meet Table A after testing.				
14	Vibration	5g's for 20 minutes, 12cycles eah of 3 orientations Test from 10-2000Hz. 12cycles each of 3 orientations	Meet Table A after testing.				
15	Resistance to Soldering Heat	No-heating Solder temperature 260C+/-5 deg C Immersion time 10s	Meet Table A after testing.				
17	ESD	Per AEC-Q200-002	ESD Rank: Refer to Item 3. Rating. No defects				
18	Solderbility	Per J-STD-002	Method B : Not Applicable 95% of the terminations is to be soldered. (Except exposed wire)				
19	Electrical Characterization	Measured : Inductance	No defects				
20	Flammability	Per UL-94	Not Applicable				
21	Board Flex	Epoxy-PCB(1.6mm) Deflection 2mm(min) 60s minimum holding time	Murata deviation request: 5s  Meet Table B after testing. <u>Table B</u> <table border="1" style="margin-left: auto; margin-right: auto; border-collapse: collapse;"> <tr> <td style="padding: 2px;">Appearance</td> <td style="padding: 2px;">No damage</td> </tr> <tr> <td style="padding: 2px;">DC resistance change</td> <td style="padding: 2px;">Within ±10%</td> </tr> </table>	Appearance	No damage	DC resistance change	Within ±10%
Appearance	No damage						
DC resistance change	Within ±10%						
22	Terminal Strength	Per AEC-Q200-006 A force of 17.7N for 60s	No defects				

# Reference Only

## 8. Specification of Packaging

### 8.1 Appearance and Dimensions of plastic tape

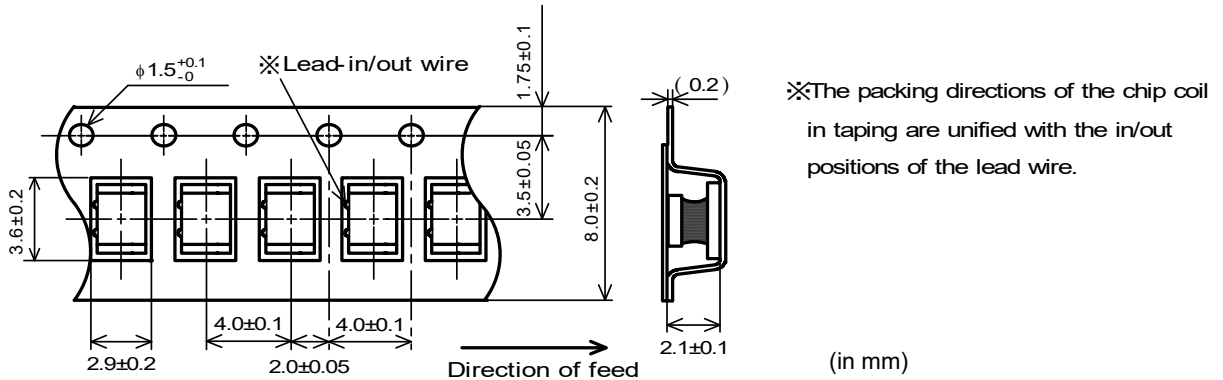

Dimension of the Cavity is measured at the bottom side.

### 8.2 Specification of Taping

- (1) Packing quantity (standard quantity)  
2,000 pcs / reel
- (2) Packing Method  
Products shall be packed in the each embossed cavity of plastic tape and sealed by cover tape.
- (3) Sprocket hole  
The sprocket holes are to the right as the tape is pulled toward the user.
- (4) Spliced point  
Plastic tape and Cover tape has no spliced point.
- (5) Missing components number  
Missing components number within 0.025% of the number per reel or 1 pc., whichever is greater, and are not continuous. The specified quantity per reel is kept.

### 8.3 Pull Strength

Embossed carrier tape	10N min.
Cover tape	5N min.

### 8.4 Peeling off force of cover tape

Speed of Peeling off	300mm/min
Peeling off force	0.2 to 0.7N (minimum value is typical)

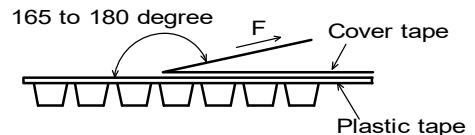

### 8.5 Dimensions of Leader-tape, Trailer and Reel

There shall be leader-tape (cover tape) and trailer-tape (empty tape) as follows.

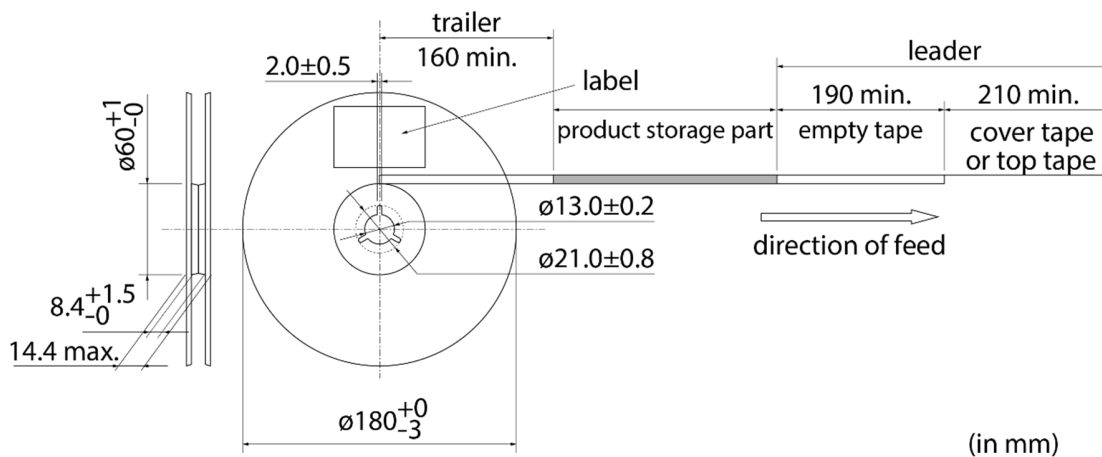



## 10. Notice

This product is designed for solder mounting. (Reflow soldering only)  
Please consult us in advance for applying other mounting method such as conductive adhesive.

### 10.1 Land pattern designing (Reflow Soldering)

Recommended land pattern for reflow soldering is as follows:  
It has been designed for Electric characteristics and solderability.  
Please follow the recommended patterns. Otherwise, their performance which includes electrical performance or solderability may be affected, or result to "position shift" in soldering process.

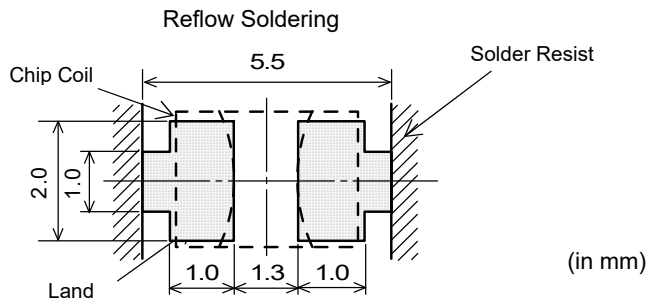

### 10.2 Flux, Solder

Flux	<ul style="list-style-type: none"> <li>• Use rosin-based flux.</li> <li>• Don't use highly acidic flux with halide content exceeding 0.2(wt)% (chlorine conversion value).</li> <li>• Don't use water-soluble flux.</li> </ul>
Solder	<ul style="list-style-type: none"> <li>• Use Sn-3.0Ag-0.5Cu solder</li> <li>• Standard thickness of solder paste : 100μm to 150μm</li> </ul>

Other flux (except above) Please contact us for details, then use.

### 10.3 Reflow soldering conditions

- Pre-heating should be in such a way that the temperature difference between solder and product surface is limited to 150°C max. Cooling into solvent after soldering also should be in such a way that the temperature difference is limited to 100°C max. Insufficient pre-heating may cause cracks on the product, resulting in the deterioration of products quality.
- Standard soldering profile and the limit soldering profile is as follows. The excessive limit soldering conditions may cause leaching of the electrode and / or resulting in the deterioration of product quality.

Reflow soldering profile

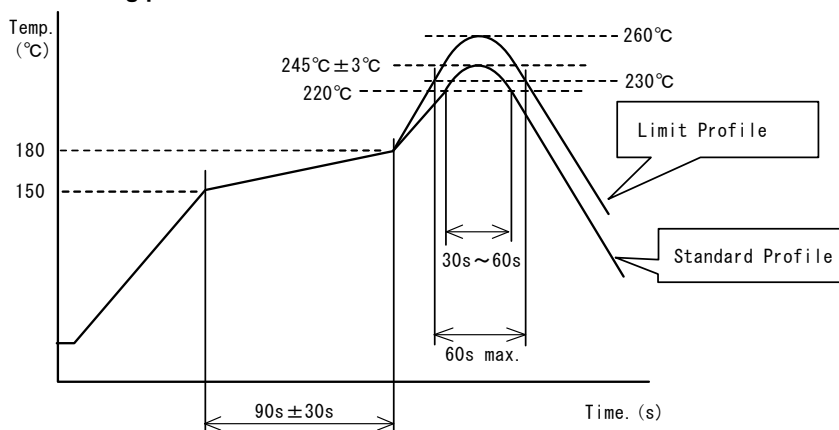

	Standard Profile	Limit Profile
Pre-heating	150~180°C、90s±30s	
Heating	above 220°C、30s~60s	above 230°C、60s max.
Peak temperature	245±3°C	260°C,10s
Cycle of reflow	2 times	2time

### 10.4 Reworking with soldering iron.

The following conditions must be strictly followed when using a soldering iron.

Pre-heating	150°C, 1 min
Tip temperature	350°C max.
Soldering iron output	80W max.
Tip diameter	φ3mm max.
Soldering time	3 (+1,-0)s
Times	2 times

Note : Do not directly touch the products with the tip of the soldering iron in order to prevent the crack on the products due to the thermal shock.

### 10.5 Solder Volume

- Solder shall be used not to be exceeded the upper limits as shown below.
- Accordingly increasing the solder volume, the mechanical stress to Chip is also increased. Exceeding solder volume may cause the failure of mechanical or electrical performance.

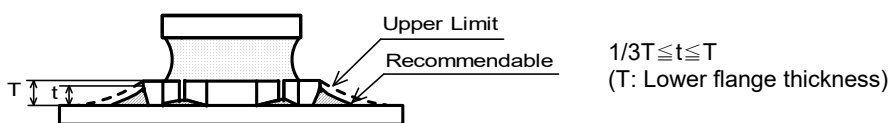

### 10.6 Product's location

The following shall be considered when designing and laying out P.C.B.'s.

- (1) P.C.B. shall be designed so that products are not subject to the mechanical stress due to warping the board.

[Products direction]

Products shall be located in the sideways direction to the mechanical stress.

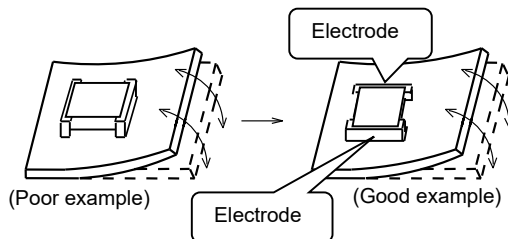

- (2) Components location on PCB separation

It is effective to implement the following measures, to reduce stress in separating the board.

It is best to implement all of the following three measures; however, implement as many measures as possible to reduce stress.

Contents of measures	Stress level
(1) Turn the mounting direction of the component parallel to the board separation surface.	$A > D^{*1}$
(2) Add slits in the board separation part.	$A > B$
(3) Keep the mounting position of the component away from the board separation surface.	$A > C$
*1 $A > D$ is valid when stress is added vertically to the perforation as with hand separation. If a cutting disc is used, stress will be diagonal to the PCB, therefore $A > D$ is invalid.	

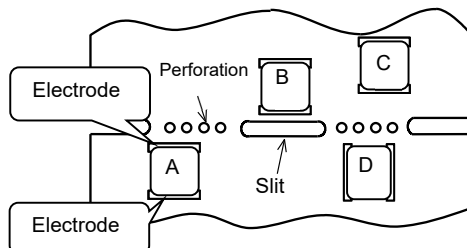

(3) Mounting components near screw holes

When a component is mounted near a screw hole, it may be affected by the board deflection that occurs during the tightening of the screw.

Mount the component in a position as far away from the screw holes as possible.

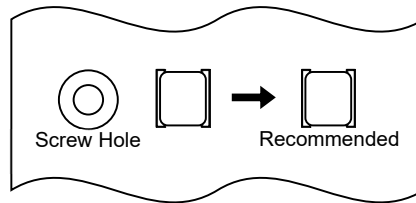

## 10.7 Cleaning Conditions

Products shall be cleaned on the following conditions.

(1) Cleaning temperature shall be limited to 60°C max.(40°C max for IPA.)

(2) Ultrasonic cleaning shall comply with the following conditions with avoiding the resonance phenomenon at the mounted products and P.C.B.

Power : 20 W / l max.      Frequency : 28kHz to 40kHz      Time : 5 minutes max.

(3) Cleaner

1. Alternative cleaner
  - Isopropyl alcohol (IPA)
2. Aqueous agent
  - PINE ALPHA ST-100S

(4) There shall be no residual flux and residual cleaner after cleaning.

In the case of using aqueous agent, products shall be dried completely after rinse with de-ionized water in order to remove the cleaner.

(5) Other cleaning

Please contact us.

## 10.8 Attention regarding product's heat generation

Please pay special attention to the product's heat generation such as beyond Operating Temperature range, mounting product in close proximity to other products that radiate heat and beyond the rated current.

## 10.9 Resin coating (moistureproof coating)

Do not make any resin coating.

The inductance value may change due to high cure-stress of resin to be used for coating/molding products. An open circuit issue may occur by mechanical stress caused by the resin, amount/cured shape of resin, or operating condition etc. Some resin contains some impurities or chloride possible to generate chlorine by hydrolysis under some operating condition may cause corrosion of wire of coil, leading to open circuit.

## 10.10 Caution for use

- Sharp material such as a pair of tweezers or other material such as bristles of cleaning brush, shall not be touched to the winding portion to prevent the breaking of wire.
- Mechanical shock should not be applied to the products mounted on the board to prevent the breaking of the core.

## 10.11 Handling of a substrate

After mounting products on a substrate, do not apply any stress to the product caused by bending or twisting to the substrate when cropping the substrate, inserting and removing a connector from the substrate or tightening screw to the substrate.

Excessive mechanical stress may cause cracking in the product.

**Bending**

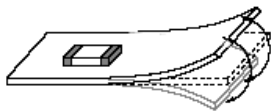

**Twisting**

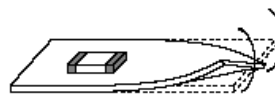

## 10.12 Storage and Handling Requirements

### (1) Storage period

Use the products within 12 months after delivered.

Solderability should be checked if this period is exceeded.

### (2) Storage conditions

- Products should be stored in the warehouse on the following conditions.

Temperature : -10 ~ 40°C

Humidity : 15 to 85% relative humidity No rapid change on temperature and humidity

The electrode of the products is coated with solder. Don't keep products in corrosive gases such as sulfur, chlorine gas or acid, or it may cause oxidization of electrode, resulting in poor solderability.

- Products should not be stored on bulk packaging condition to prevent the chipping of the core and the breaking of winding wire caused by the collision between the products.
- Products should be stored on the palette for the prevention of the influence from humidity, dust and so on.
- Products should be stored in the warehouse without heat shock, vibration, direct sunlight and so on.

### (3) Handling Condition

Care should be taken when transporting or handling product to avoid excessive vibration or mechanical shock.

## 11. Note

(1) Please make sure that your product has been evaluated in view of your specifications with our product being mounted to your product.

(2) You are requested not to use our product deviating from the reference specifications.

(3) The contents of this reference specification are subject to change without advance notice.

Please approve our product specifications or transact the approval sheet for product specifications before ordering.

## Looking for pricing, stock, or lifecycle information?

Click below to explore more details on WIN SOURCE:

- ⊖ [View LQH32NH100J23L on WIN SOURCE](#)
- ⊖ [Murata Electronics North America Information](#)

## Optimize Your Supply Chain with WIN SOURCE Solutions

- ✓ Global Sourcing Solution
- ✓ Obsolete Management
- ✓ Cost Control Management
- ✓ Shortage Management
- ✓ Alternative Solution
- ✓ Excess Inventory Management