



**THE DATASHEET OF  
FH48-20S-0.5SV**



# 0.5 mm Pitch, 6.18 mm Height, Vertical Mount, Shielded FFC High Speed Connectors

## FH48 Series

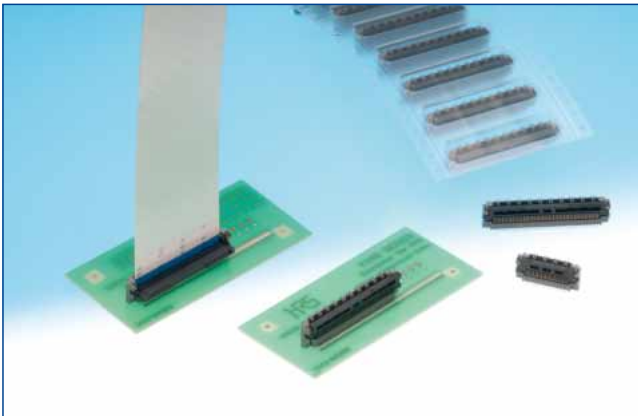

Supports the next generation chip  
V-by-One® HS\* by THINE

\*High speed serial interface  
technology for picture transmission



### ■ Features

#### 1. Accepts impedance matched shielded FFC

The FH48 Series is equipped with a ground terminal and can be used with impedance matched, shielded FFC.

#### 2. Impedance matched terminal design

The signal terminal is designed for impedance control and is capable of handling high speed transmissions.

#### 3. Highly reliable and secure structure

The design of the FH48 series follows in the footsteps of another popular Hirose connector, the FH40 series. The FFC positioning mechanism and rugged structure combine to prevent accidental unlocking and produce a secure connection.

#### 4. Simplified operations with a flip lock system

The flip lock design allows a smoother simpler FFC operation. It requires less force to rotate the actuator and delivers a tactile click to reinforce that the lock has secured the connection.

#### 5. Suitable for automatic pick-n-place mounting

Offered in tape and reel packaging that is compatible with automatic machine mounting. (1,000 pieces per reel)

#### 6. Halogen free

All materials and substances used to produce this product comply with Halogen-free standards.\*Standards by IEC 61249-2-21Br: 900ppm or lower, Cl: 900ppm or lower, Br+Cl: 1,500ppm or lower

#### ● Inserting FFC

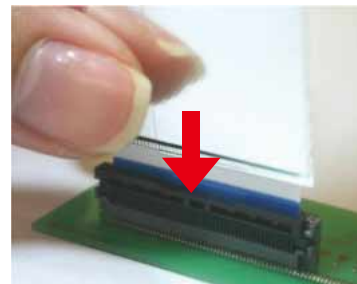

#### ● Lock completed

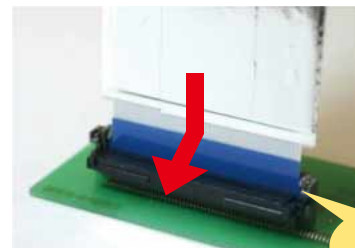

#### ● Uses the same FFC that the FH41 Series (horizontal connection) uses.



#### ● Shielded FFC

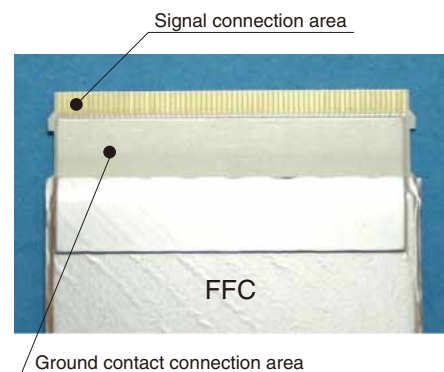

## Product specifications

Rating	Rated current	0.5A (Note 1)	Operating temperature range	-40 to +85°C (Note 2)	Storage temperature range	-10 to +50°C (Note 3)
	Rated voltage	AC 50 Vrms	Operating humidity range	Relative humidity of 90% or lower (no dew condensation)	Storage humidity range	Relative humidity of 90% or lower (no dew condensation)

Applicable FPC and FFC terminal specifications t= 0.3 ±0.05, gold plating (GND plate: t= 0.5 ±0.05, tin plating)

Items	Specifications	Conditions
1. Insulation resistance	Minimum of 500 MΩ	Measured at DC 100 V.
2. Withstanding voltage	No flashover or insulation damage	AC 150 Vrms applied for 1 minute
3. Contact resistance	Maximum of 100 mΩ *Incl. FFC conductor resistance	Measured at 1mA.
4. Durability	Contact resistance: Maximum of 100 mΩ No damage, cracks or loose part.	20 mating cycles
5. Vibration resistance	No electrical discontinuity for more than 1μs Contact resistance: Maximum of 100 mΩ No damage, cracks or loose part.	Frequency 10 to 55Hz with half amplitude 0.75mm in 3 directions, 10 cycles each.
6. Impact resistance	No electrical discontinuity for more than 1μs Contact resistance: Maximum of 100 mΩ No damage, cracked or loose parts.	Acceleration: 981m/s <sup>2</sup> , duration time: 6ms, With half sine waves in 3 both directions, 3 times each.
7. Humidity resistance in ordinary conditions	Contact resistance: Maximum of 100 mΩ Insulation resistance: Minimum of 50 MΩ No damage, cracked or loose parts.	Left for 96 hours at temperature 40°C, humidity 90 to 95%
8. Temperature cycle	Contact resistance: Maximum of 100 mΩ Insulation resistance: Minimum of 50 MΩ No damage, cracked or loose parts.	Temperature: -40 → +15 to +35 → +85 → +15 to +35°C Time: 30 → 2 to 3 → 30 → 2 to 3 min. 5 cycles in the above conditions
9. Solder heat resistance	No external deformation or significant shaking of terminal	Reflow: Recommended temperature profile Manual soldering: 350±5°C for 5 sec.

(Note 1) Use 70% of the rated current for all the cores.

(Note 2) Including the temperature increase when the power is on.

(Note 3) Here, the storage means that unused products are stored before installed on a board for a long period of time.

For the products installed on a board with no power supplied, the operating temperature and humidity ranges shall be applied.

## Materials

Parts	Materials	Color/finishing	Remarks
Insulating parts	LCP	Gray	UL94V-0
		Black	
Terminal	Phosphor bronze	Gold plating	—
		Pure tin reflow plating	
Lock metal parts	Phosphor bronze (plating material)	Nickel plating	

## Product number structure

Refer to this page when determining product specifications by model types. Please place orders with part numbers listed in this catalog. The characteristics and specifications of the product described in this catalog are reference values. Please make sure to check the latest delivery specifications at the time of product use.

**FH 48 - 50S - 0.5 SV**

①      ②      ③      ④      ⑤

① Series name: FH	④ Contact pitch: 0.5 mm
② Series number: 48	⑤ Terminal shape
③ Number of contacts: 20 to 68	SV...SMT vertical implementation type

## Connector dimension diagram

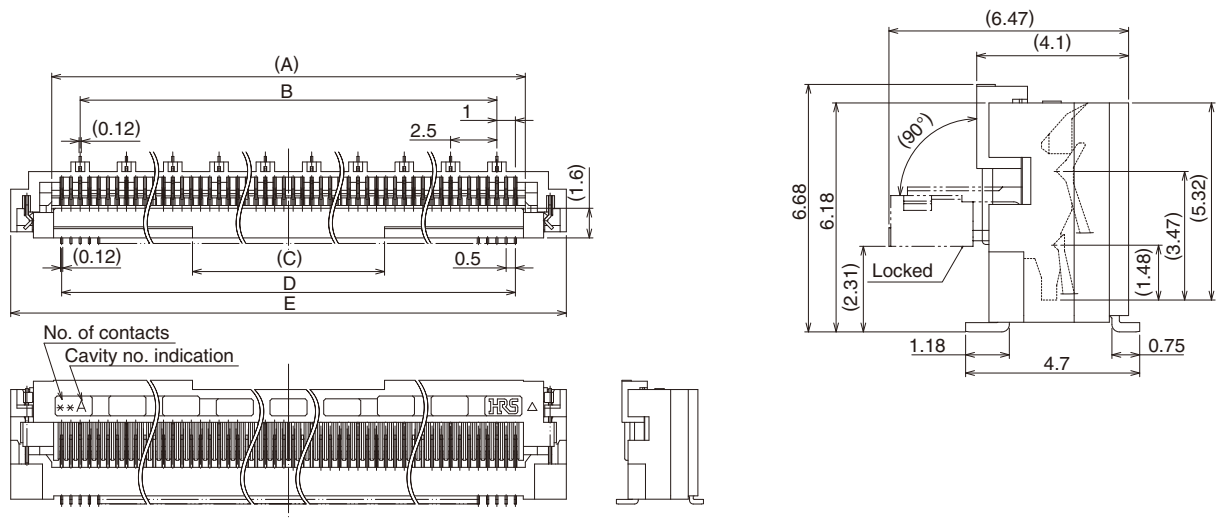

- Note 1. The flatness of the terminal and the metal lead is 0.1 MAX.  
 2. This product is emboss packaged. For details, see the package specification diagram on page 6.  
 3. Black marks may appear in the mold resin, but they will not negatively affect the performance of these connectors.  
 4. The color of the plating may change after the reflow process, but it will not negatively affect the performance of these connectors.

## Connector dimension table

Unit: mm

Product number	HRS No.	Number of contacts	Number of ground contacts	A	B	C	D	E
FH48-20S-0.5SV	CL580-3104-1-00	20	4	10.57	7.5	8.37	9.5	15
FH48-21S-0.5SV	CL580-3103-9-00	21	4	11.07	7.5	8.87	10	15.5
FH48-31S-0.5SV	CL580-3102-6-00	31	6	16.07	12.5	10.37	15	20.5
FH48-40S-0.5SV	CL580-3100-0-00	40	8	20.57	17.5	10.37	19.5	25
FH48-50S-0.5SV	CL580-3101-3-00	50	10	25.57	22.5	10.37	24.5	30
FH48-68S-0.5SV	CL580-3105-4-00	68	13	34.57	30	10.37	33.5	39

(Note 1) This product is packaged on tape and reel and is only sold in full reel quantities of 1,000 pieces per reel. Please place orders by full reel quantities.

### Recommended land and metal mask dimension diagram

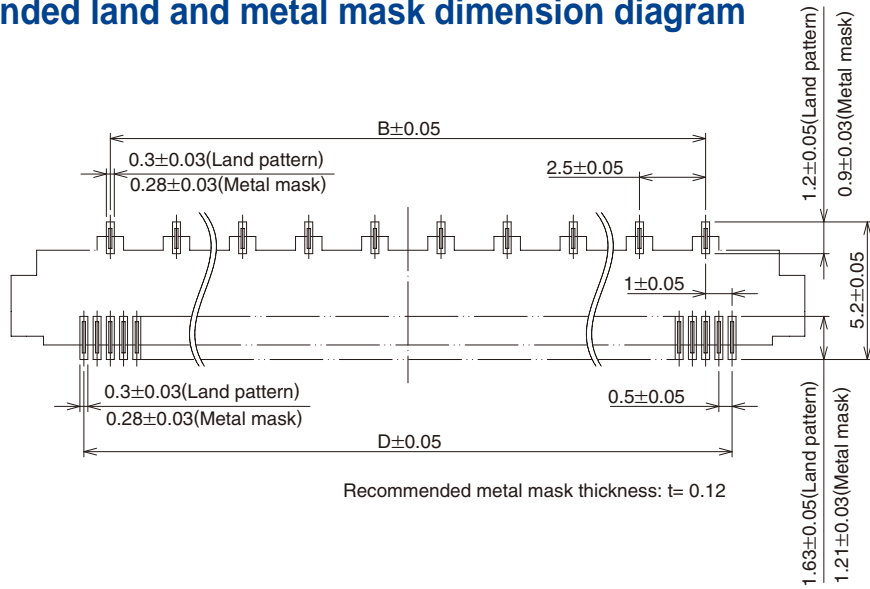

### Recommended FFC dimension diagram

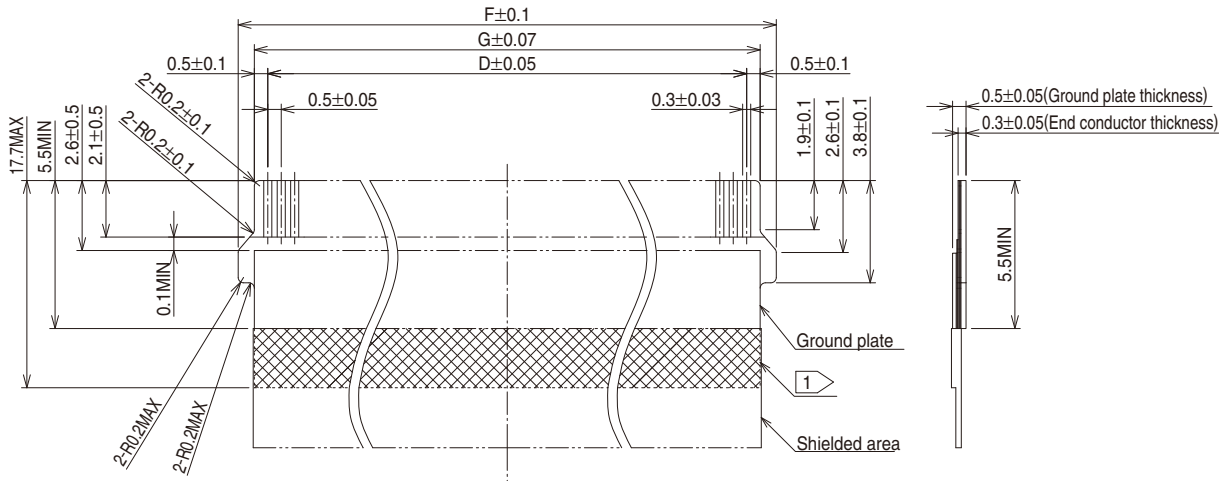

Note 1: Place the shielded area on the ground plate.

### Recommended land, metal mask and FFC dimension table

Unit: mm

Product number	HRS No.	Number of contacts	Number of ground contacts	B	D	F	G
FH48-20S-0.5SV	CL580-3104-1-00	20	4	7.5	9.5	11.7	10.5
FH48-21S-0.5SV	CL580-3103-9-00	21	4	7.5	10	12.2	11
FH48-31S-0.5SV	CL580-3102-6-00	31	6	12.5	15	17.2	16
FH48-40S-0.5SV	CL580-3100-0-00	40	8	17.5	19.5	21.7	20.5
FH48-50S-0.5SV	CL580-3101-3-00	50	10	22.5	24.5	26.7	25.5
FH48-68S-0.5SV	CL580-3105-4-00	68	13	30	33.5	35.7	34.5

### ◆ FH48 Series FFC material structure (recommended specifications)

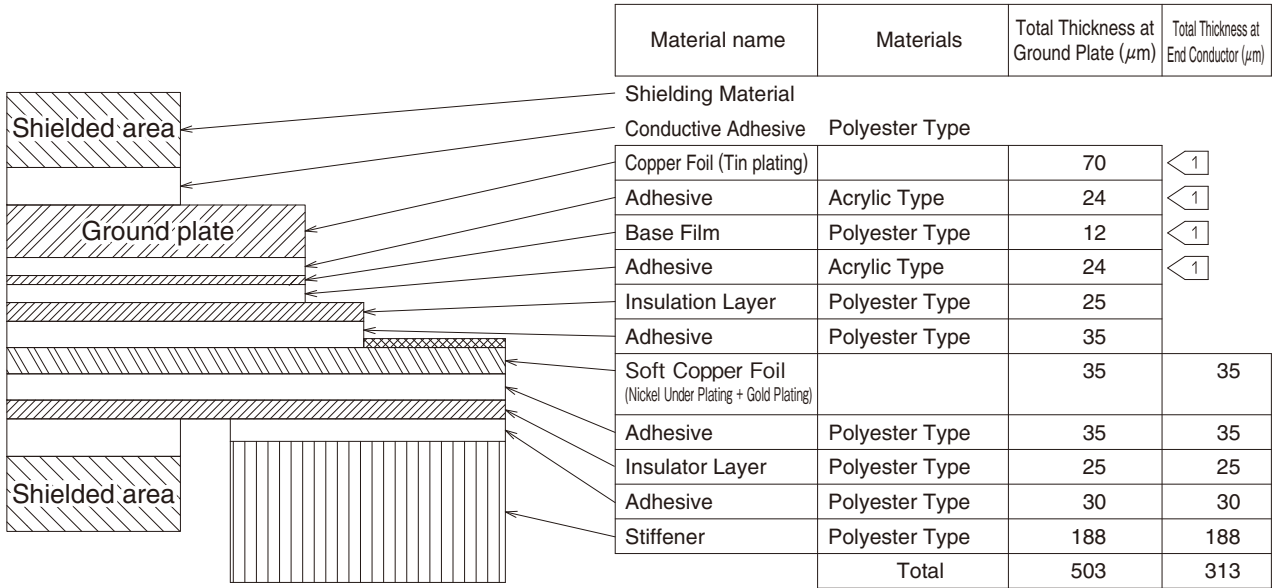

① Contact us to change this specifications and thickness configuration.

### ◆ Temperature profile

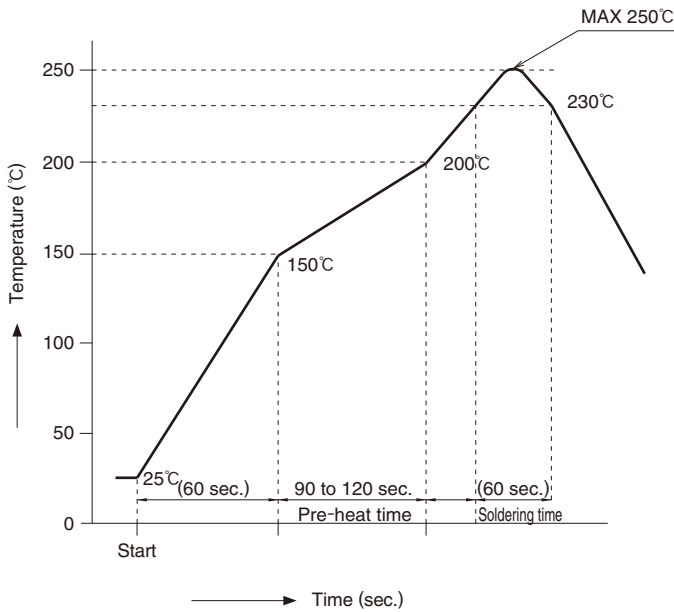

#### Application conditions

- Reflow type : Reflow with far-infrared ray and hot air combined
- Reflow furnace atmosphere : Air
- Solder : Cream type Sn/3.0Ag/0.5Cu (Senju Metal Industry, M705-221CM5-42-10.5)
- Test board : Board material and size  
Glass epoxy 25x55x1.0mm  
Land dimension 0.3x1.63, 0.3x1.2 mm
- Metal mask : Thickness 0.12 mm  
Opening dimensions 0.28x1.21, 0.28x0.9 mm

This solder profile is based on the conditions provided above.

Please check the mounting conditions before use, conditions such as solder paste types, manufacturer, PCB size and any other soldering materials may alter the performance of such materials.

## Package specification diagram

### Emboss carrier tape dimension diagram

(Maximum tape width: 24 mm)

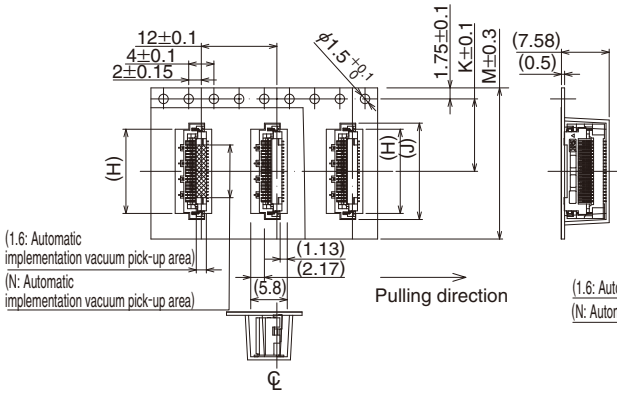

(Minimum tape width: 32 mm)

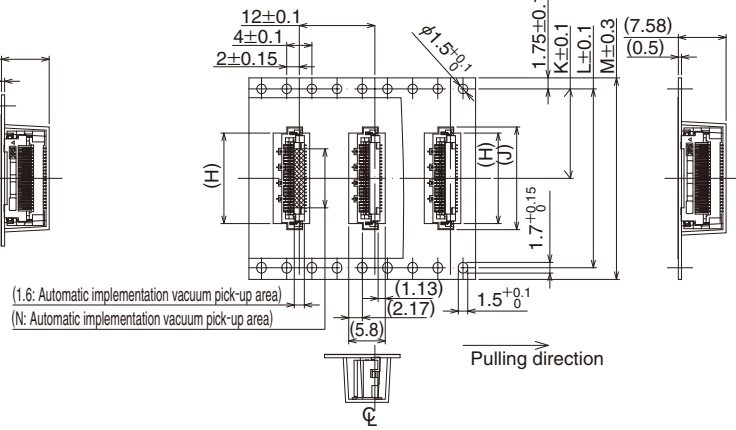

### Reel dimension diagram

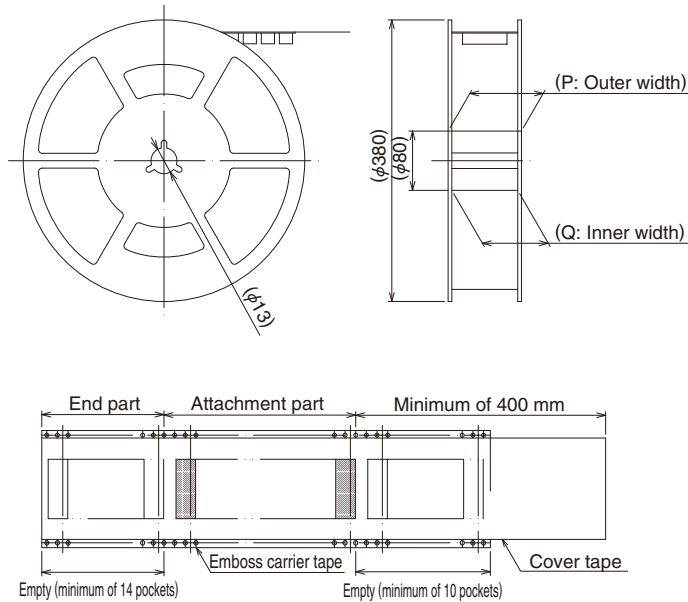

## Package specification dimension table

Unit: mm

Product number	HRS No.	Number of contacts	Number of ground contacts	H	J	K	L	M	N	P	Q
FH48-20S-0.5SV	CL580-3104-1-00	20	4	13.37	15.3	11.5	-	24	8.37	29.4	25.4
FH48-21S-0.5SV	CL580-3103-9-00	21	4	13.87	15.8	11.5	-	24	8.87	29.4	25.4
FH48-31S-0.5SV	CL580-3102-6-00	31	6	18.87	20.8	20.2	40.4	44	10.37	49.4	45.4
FH48-40S-0.5SV	CL580-3100-0-00	40	8	23.37	25.3	20.2	40.4	44	10.37	49.4	45.4
FH48-50S-0.5SV	CL580-3101-3-00	50	10	28.37	30.3	20.2	40.4	44	10.37	49.4	45.4
FH48-68S-0.5SV	CL580-3105-4-00	68	13	37.37	39.3	26.2	52.4	56	10.37	61.4	57.4

## ◆ Connector handling and precautions

### Handling and precautions

Care must be taken to the handling of this connector. Check the followings before using the product. The figures and values described in the precautions may differ from the standard values of the product.

#### [Precautions for board implementation]

- ◆ Board warp
  - Avoid board warp if possible.
  - The flatness of the connector is 0.1mm or smaller, and a large warp could cause solder failure.
- ◆ Load on connector
  - When the emboss is extracted from the reel or when the connector is vacuum picked up from the emboss, avoid an excessive force (over 1 N) to the un-mounted connector. Otherwise the connector could be damaged.
  - Also, do not insert FFC or handle the connector before inserting the connector.

#### [Precautions for board handling after implementation]

- ◆ Load on board
  - When a board is divided to make multiple boards
  - When a board is fixed with screws.
  - In the assembling process such as the above, no load should be applied to the board. Otherwise the connector could be damaged.
- ◆ Board warp
  - When the board width is 100mm, the board warp should be 1mm or smaller for the use. (Right figure)
  - The board warp could cause a load on the connector and damage it.

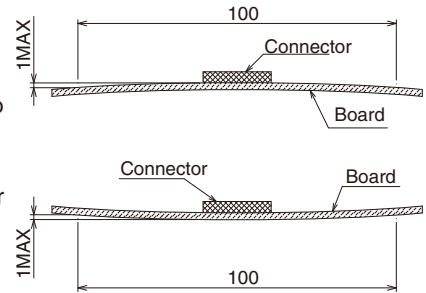

#### [Precautions for FFC insertion and mating]

- ◆ Opening and closing of actuator
  - The connector, when delivered, is ready for FFC insertion. When FFC is inserted and the actuator is rotated by 90°, the connector is in a FFC mating locked state. Do not rotate the actuator before inserting FFC.
- ◆ Contact direction
  - Insert the connector with the FFC's exposed conductor side on the housing and with the FFC stiffening plate on the actuator.

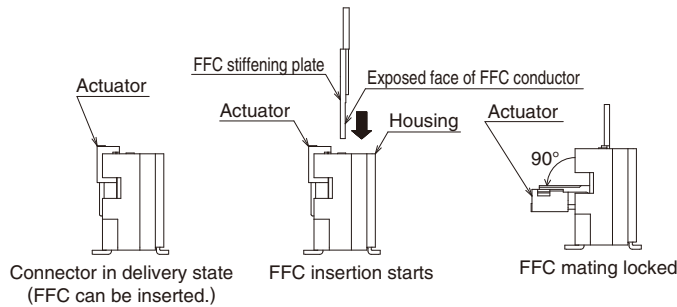

- ◆ FFC insertion
  - Securely insert FFC vertically to the connector.

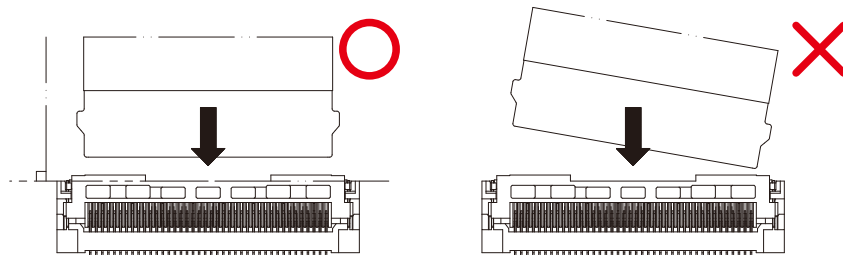

Handling and precautions

◆ Actuator handling

- (1) The actuator can rotate about the rotation axis. Handle it as it rotates.
- (2) The actuator does not rotate by more than 90°. Do not apply an excessive force to rotate it more. Otherwise the terminal is deformed or the actuator is damaged.
- (3) Do not pull or hook the actuator. Otherwise damage could be caused. (Only the rotation motion described above is allowed.)

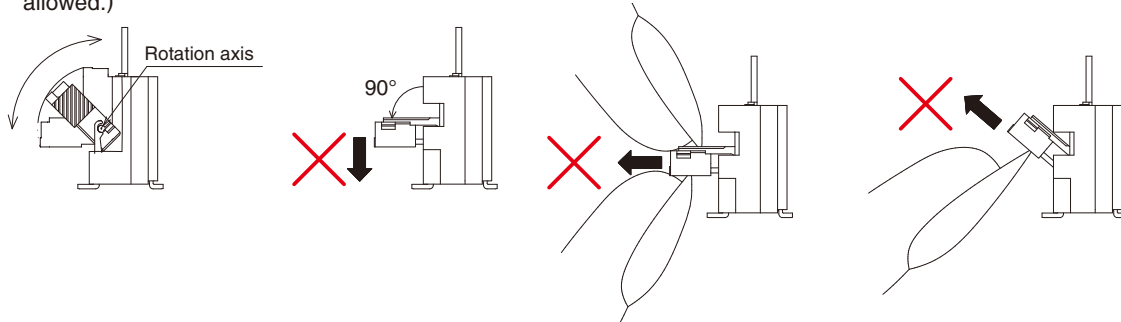

◆ Check of lock

- (1) When locking the actuator, make sure that it is parallel to the board face.
- (2) After mating and locking FFC, make sure that the FFC positioning tab does not come on the FFC positioning guide. If the FFC positioning tab runs over the FFC positioning guide, contact failure could be caused.

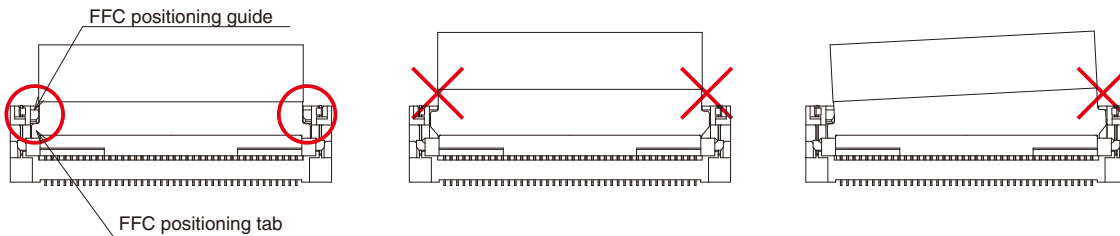

**[Precautions for FFC handling after mating FFC]**

◆ Load on FFC

When handling FFC, do not apply a load directly to it. If FFC is bent near the connector when it is used, contact failure or disconnection or damage of FFC could be caused. In particular, do not bend FFC sharply at the insertion point to the actuator direction.

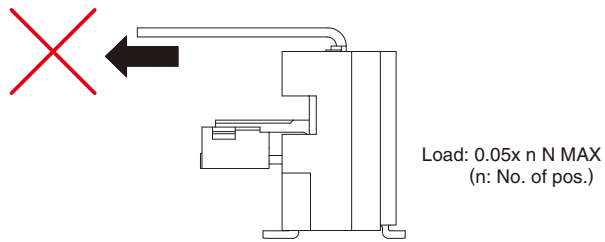

**[Precautions for pulling FFC]**

- ◆ FFC needs to be pulled out with the actuator locked. To circumvent the FFC positioning guide, pull it out at an angle of about 7° from the perpendicular direction to the board.

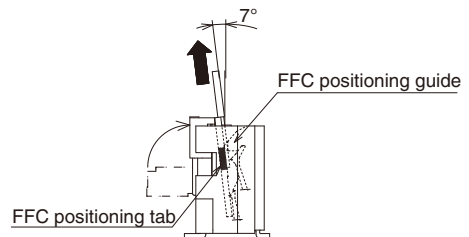

**[Other precautions]**

◆ Precautions for manual soldering

For manual soldering for repair or other purposes, see the followings.

- (1) Do not make reflow or manual soldering with FFC inserted in the connector.
- (2) Do not apply excessive heat. Prevent a soldering iron from contacting a part other than the lead wire of the connector. Otherwise the connector may deform or melt.
- (3) Do not supply an excessive amount of solder (flux).

If too much solder (flux) is applied on the terminal, a part of the solder or flux would adhere to the contact or actuator's rotation axis and cause contact failure or rotation failure of the actuator.



**HIROSE ELECTRIC CO.,LTD.**

6-3,Nakagawa Chuoh-2-Chome,Tsuzuki-Ku,Yokohama-Shi 224-8540,JAPAN  
 TEL: +81-45-620-3526 Fax: +81-45-591-3726  
<http://www.hirose.com>  
<http://www.hirose-connectors.com>

## Looking for pricing, stock, or lifecycle information?

Click below to explore more details on WIN SOURCE:

-  [View FH48-20S-0.5SV on WIN SOURCE](#)
-  [Hirose Electric Co Ltd Information](#)

## Optimize Your Supply Chain with WIN SOURCE Solutions

-  Global Sourcing Solution
-  Obsolete Management
-  Cost Control Management
-  Shortage Management
-  Alternative Solution
-  Excess Inventory Management