



**THE DATASHEET OF
LTM2985IY#PBF**



Isolated High Accuracy Digital Temperature Measurement System with EEPROM

FEATURES

- 5000V_{RMS} Isolated Power and SPI Interface
- Directly Digitizes 2-, 3- or 4-Wire RTDs, Thermocouples, Thermistors and Diodes
- 10 Flexible Inputs Allow Interchanging Sensors
- Automatic Thermocouple Cold Junction Compensation
- Built-In Standard and User-Programmable Coefficients for Thermocouples, RTDs and Thermistors
- Automatic Burn Out, Short-Circuit and Fault Detection
- Buffered Inputs Allow External Protection
- Simultaneous 50Hz/60Hz Rejection
- Includes 15ppm/°C (Max) Reference
- Includes Special Protection Modes
- On-Chip EEPROM Stores Channel Configuration Data and Custom Coefficients

APPLICATIONS

- Direct Thermocouple Measurements
- Direct RTD Measurements
- Direct Thermistor Measurements
- Custom Sensor Applications

DESCRIPTION

The LTM[®]2985 measures a wide variety of temperature sensors and digitally outputs the result, in °C or °F, with 0.1°C accuracy and 0.001°C resolution. The LTM2985 can measure the temperature of virtually all standard (Type B, E, J, K, N, S, R, T) or custom thermocouples, automatically compensate for cold junction temperatures and linearize the results. The device can also measure temperature with standard 2-, 3- or 4-wire RTDs, thermistors and diodes. The LTM2985 includes excitation current sources and fault detection circuitry appropriate for each type of temperature sensor.

The LTM2985 is an isolated 10-channel temperature measurement system software compatible with the LTC2986-1. It provides 5kV isolated power and SPI interface to the precision temperature-to-bits converter. The LTM2985 also includes a user-programmable EEPROM for custom sensor data.

All registered trademarks and trademarks are the property of their respective owners. Patents Pending

TYPICAL APPLICATION

Universal Isolated Temperature Measurement System

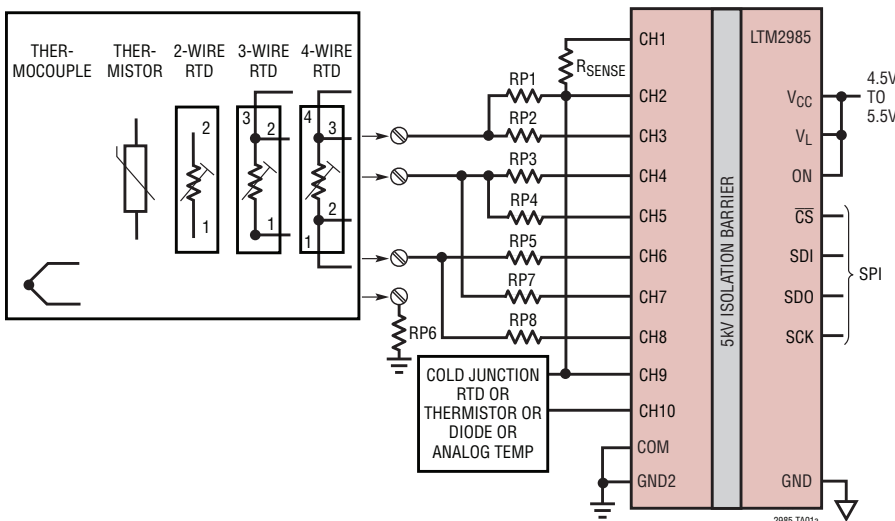

Typical Temperature Error Contribution

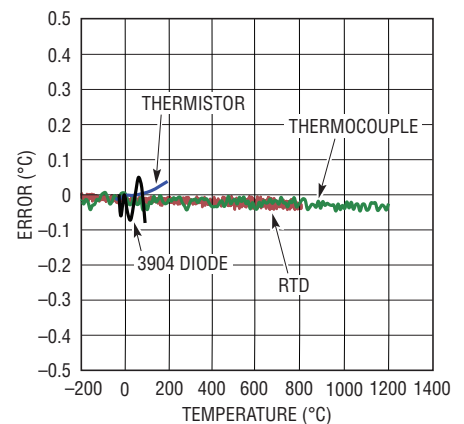

2985 TA01b

TABLE OF CONTENTS

Features	1
Applications	1
Typical Application	1
Description.....	1
Absolute Maximum Ratings.....	3
Order Information	3
Pin Configuration	3
Complete System Electrical Characteristics.....	4
ADC Electrical Characteristics	5
Reference Electrical Characteristics.....	5
Digital Inputs and Digital Outputs	6
Isolation Characteristics	6
LTM2985 EEPROM Characteristics.....	7
Typical Performance Characteristics	8
Pin Functions	11
Block Diagram.....	12
Test Circuits	13
Timing Diagram	13
Overview	14
Applications Information	18
EEPROM Overview.....	24
EEPROM Read/Write Validation	24
EEPROM Write Operation	24
EEPROM Read Operation.....	25
Thermocouple Measurements	26
Diode Measurements.....	29
RTD Measurements	33
Thermistor Measurements.....	52
Global Configuration Register.....	61
Input Overvoltage Protection – Overview.....	61
Active Analog Temperature Sensors	67
Direct ADC Measurements.....	71
Supplemental Information.....	76
2- and 3-Cycle Conversion Modes.....	76
Running Conversions Consecutively on Multiple Channels.....	76
Entering/Exiting Sleep Mode.....	77
MUX Configuration Delay.....	77
Reference Considerations	77
Custom Thermocouples	78
Custom RTDs	81
Custom Thermistors	84
Package Description	89
Typical Application	90
Related Parts	90

ABSOLUTE MAXIMUM RATINGS

(Notes 1)

Supply Voltage (V_{CC}) to GND -0.3V to 6V

V_L to GND -0.3V to 6V

V_{CC2} to GND2 -0.3V to 6V

Logic Inputs:

SCK, SDI, \overline{CS} , \overline{SDOE} , ON to GND ... -0.3V to ($V_L + 0.3V$)

DIN to GND2 -0.3V to ($V_{CC2} + 0.3V$)

Logic Outputs:

DOUT, SDO to GND -0.3V to ($V_L + 0.3V$)

INT to GND2 -0.3V to ($V_{CC2} + 0.3V$)

Analog Input Pins (CH1 to CH10, COM)

to GND2 -0.3V to ($V_{CC2} + 0.3V$)

Input Current (CH1 to CH10, COM) $\pm 15mA$

V_{REF} to GND2 -0.3V to ($V_{CC2} + 0.3V$)

Peak Solder Reflow Package Body Temperature 245°C

PIN CONFIGURATION

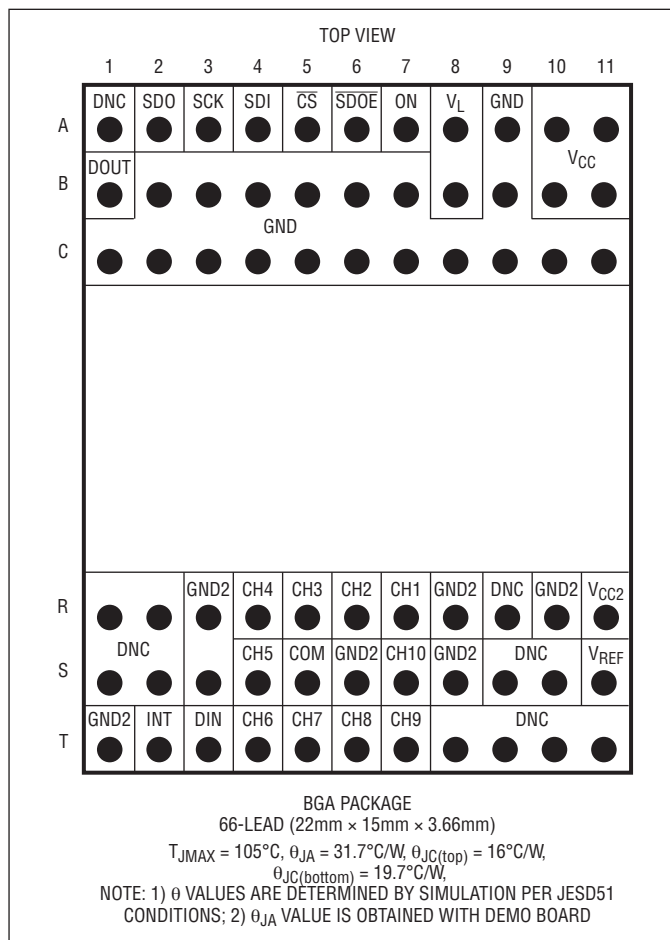

ORDER INFORMATION

PART NUMBER	PAD OR BALL FINISH	PART MARKING		PACKAGE TYPE	MSL RATING	TEMPERATURE RANGE
		DEVICE	FINISH CODE			
LTM2985CY#PBF	SAC305 (RoHS)	LTM2985Y	e1	BGA	4	0°C to 70°C
LTM2985IY#PBF						-40°C to 85°C

- Device temperature grade is indicated by a label on the shipping container.
- Pad or ball finish code is per IPC/JEDEC J-STD-609.
- [Recommended BGA PCB Assembly and Manufacturing Procedures.](#)
- [BGA Package and Tray Drawings](#)

COMPLETE SYSTEM ELECTRICAL CHARACTERISTICS

The ● denotes the specifications which apply over the full operating temperature range, otherwise specifications are at $T_A = 25^\circ\text{C}$. $V_L = 3.3\text{V}$ and $\text{GND} = \text{GND2} = 0\text{V}$, $\text{ON} = V_L$ unless otherwise noted.

SYMBOL	PARAMETER	CONDITIONS		MIN	TYP	MAX	UNITS
Input Supplies							
V_{CC}	Input Supply Range		●	4.5	5	5.5	V
V_L	Logic Supply Range		●	1.62		5.5	V
I_{CC}	Input Supply Current	$\text{ON} = V_L$, No Load	●			80	mA
I_L	Logic Supply Current	$\text{ON} = 0\text{V}$ $\text{ON} = V_L$	●		10	10	μA μA
Output Supplies							
V_{CC2}	Regulated Output Voltage	No Load (Note 3)	●	4.75	5	5.25	V
	Output Voltage Operating Range			3		5.5	V
	Line Regulation	External $I_{\text{LOAD}} = 1\text{mA}$, $\text{MIN} \leq V_{CC} \leq \text{MAX}$	●		25	100	mV
	Load Regulation	External $I_{\text{LOAD}} = 100\mu\text{A}$ to 1mA	●			6	mV
I_{CC2}	Output Short Circuit Current	$V_{CC2} = 0\text{V}$			150		mA
	Current Limit	$\Delta V_{CC2} \leq -5\%$	●	1			mA
Logic							
V_{ITH}	Input Threshold Voltage	$\text{ON}, \overline{\text{SDOE}}, \text{SCK}, \text{SDI}, \overline{\text{CS}} 1.62\text{V} \leq V_L < 2.35\text{V}$	●	$0.25 \cdot V_L$		$0.75 \cdot V_L$	V
		$\text{ON}, \overline{\text{SDOE}}, \text{SCK}, \text{SDI}, \overline{\text{CS}} 2.35\text{V} \leq V_L \leq 5.5\text{V}$	●	$0.33 \cdot V_L$		$0.67 \cdot V_L$	V
		DIN	●	$0.33 \cdot V_{CC2}$		$0.67 \cdot V_{CC2}$	V
I_{IN}	Input Current	$\text{ON}, \overline{\text{SDOE}}, \text{SCK}, \text{SDI}, \overline{\text{CS}}, \text{DIN}, V_L = 5\text{V},$ $V_{\text{IN}} = 0\text{V}, 5\text{V}$	●			± 1	μA
V_{HYS}	Input Hysteresis	(Note 3)			150		mV
V_{OH}	Output High Voltage	DOUT, SDO $I_{\text{LOAD}} = -1\text{mA}, 1.62\text{V} \leq V_L < 3\text{V}$ $I_{\text{LOAD}} = -4\text{mA}, 3\text{V} \leq V_L \leq 5.5\text{V}$	●	$V_L - 0.4$			V
V_{OL}	Output Low Voltage	DOUT, SDO $I_{\text{LOAD}} = 1\text{mA}, 1.62\text{V} \leq V_L < 3\text{V}$ $I_{\text{LOAD}} = 4\text{mA}, 3\text{V} \leq V_L \leq 5.5\text{V}$	●			0.4	V
I_{SC}	Short-Circuit Current	$0\text{V} \leq (\text{DOUT}, \text{SDO}) \leq V_L$	●			± 85	mA

ADC ELECTRICAL CHARACTERISTICS

The ● denotes the specifications which apply over the full operating temperature range, otherwise specifications are at $T_A = 25^\circ\text{C}$.

PARAMETER	CONDITIONS	MIN	TYP	MAX	UNITS	
Resolution (No Missing Codes)	$-\text{FS} \leq V_{\text{IN}} \leq +\text{FS}$	24			Bits	
Integral Nonlinearity	$V_{\text{IN(CM)}} = 1.25$ (Note 14)	●	2	30	ppm of V_{REF}	
Offset Error		●	0.5	2	μV	
Offset Error Drift	(Note 3)	●	10	20	$\text{nV}/^\circ\text{C}$	
Positive Full-Scale Error	(Notes 2, 14)	●		100	ppm of V_{REF}	
Positive Full-Scale Drift	(Notes 2, 14)	●	0.1		ppm of $V_{\text{REF}}/^\circ\text{C}$	
Input Leakage	I-Grade, C-Grade (Note 18)	●		1	nA	
Negative Full-Scale Error	(Notes 2, 14)	●		100	ppm of V_{REF}	
Negative Full-Scale Drift	(Notes 2, 14)	●	0.1		ppm of $V_{\text{REF}}/^\circ\text{C}$	
Input Referred Noise	I-Grade, C-Grade (Note 4)	●	0.8	1.5	μV_{RMS}	
Common Mode Input Range		●	-0.05	$V_{\text{CC2}} - 0.3$	V	
RTD Excitation Current	(Note 15)	●	-25	Table 33	25	%
RTD Excitation Current Matching	Continuously Calibrated	●	Error within Noise Level of ADC		V	
Thermistor Excitation Current	(Note 15)	●	-37.5	Table 57	37.5	%
Input Range	All Analog Input Channels	●	-0.05	$V_{\text{CC2}} - 0.3$	V	
Output Rate	Two Conversion Cycle Mode (Notes 5, 8)	●	150	164	170	ms
	Three Conversion Cycle Mode (Notes 5, 8)	●	225	246	255	ms
Input Common Mode Rejection	50Hz/60Hz (Note 3)	●	120		dB	
Input Normal Mode Rejection	60Hz (Notes 3, 6)	●	120		dB	
	50Hz (Notes 3, 7)	●	120		dB	
	50Hz/60Hz (Notes 3, 5, 8)	●	75		dB	
Analog Power-Up	(Note 10)	●		100	ms	
Digital Initialization	(Note 11)	●		100	ms	

REFERENCE ELECTRICAL CHARACTERISTICS

The ● denotes the specifications which apply over the full operating temperature range, otherwise specifications are at $T_A = 25^\circ\text{C}$.

PARAMETER	CONDITIONS	MIN	TYP	MAX	UNITS
Output Voltage	V_{REF} (Note 9)	2.49		2.51	V
Output Voltage Temperature Coefficient	I-Grade	●	3	15	$\text{ppm}/^\circ\text{C}$
	C-Grade	●	3	20	$\text{ppm}/^\circ\text{C}$
Load Regulation	$I_{\text{OUT(SOURCE)}} = 100\mu\text{A}$	●		5	mV/mA
	$I_{\text{OUT(SINK)}} = 100\mu\text{A}$	●		5	mV/mA
Output Voltage Noise	$0.1\text{Hz} \leq f \leq 10\text{Hz}$		4		$\mu\text{V}_{\text{P-P}}$
	$10\text{Hz} \leq f \leq 1\text{kHz}$		4.5		$\mu\text{V}_{\text{P-P}}$
Output Short Circuit Current	Short V_{REF} to GND		40		mA
	Short V_{REF} to V_{CC2}		30		mA
Long Term Drift of Output Voltage	(Notes 3, 12)		60		$\text{ppm}/\sqrt{\text{kHr}}$
Hysteresis	$\Delta T = 0^\circ\text{C}$ to 70°C (Note 13)		30		ppm
	$\Delta T = -40^\circ\text{C}$ to 85°C (Note 13)		70		ppm

DIGITAL INPUTS AND DIGITAL OUTPUTS

The ● denotes the specifications which apply over the full operating temperature range, otherwise specifications are at $T_A = 25^\circ\text{C}$.

SYMBOL	PARAMETER	CONDITIONS	MIN	TYP	MAX	UNITS
	External SCK Frequency Range		●	0	1.5	MHz
	External SCK LOW Period		●	350		ns
	External SCK HIGH Period		●	350		ns
	$\overline{\text{SDOE}} \square$ to SDO Valid $\square\square$	$R_{\text{LOAD}} = 1\text{k}\Omega$, $C_{\text{LOAD}} = 15\text{pF}$	●	0	400	ns
	$\overline{\text{SDOE}} \square$ to SDO Hi-Z	(Note 3) $R_{\text{LOAD}} = 1\text{k}\Omega$, $C_{\text{LOAD}} = 15\text{pF}$	●	0	200	ns
t_1	$\overline{\text{CS}} \square$ to SCK \square		●	200		ns
t_2	SCK \square to SDO Valid		●		425	ns
t_3	SDO Hold After SCK \square		●	10		ns
t_4	SDI Setup Before SCK \square		●	100		ns
t_5	SDI Hold After SCK \square		●	200		ns
t_R	Rise Time	$C_{\text{LOAD}} = 15\text{pF}$	●		3 12.5	ns
t_F	Fall Time	$C_{\text{LOAD}} = 15\text{pF}$	●		3 12.5	ns

ISOLATION CHARACTERISTICS

The ● denotes the specifications which apply over the full operating temperature range, otherwise specifications are at $T_A = 25^\circ\text{C}$.

PARAMETER	CONDITIONS	MIN	TYP	MAX	UNITS
Rated Dielectric Insulation Voltage	1 Minute, Derived from 1 Second Test (Notes 20, 21)	5000			V_{RMS}
Rated Dielectric Insulation Voltage	1 Second (Note 3)	6000			V_{RMS}
Common Mode Transient Immunity	$V_L = \text{ON} = 3.3\text{V}$, $V_{\text{CM}} = 1\text{kV}$, $\Delta t = 33\text{ns}$	30	50		$\text{kV}/\mu\text{s}$
Maximum Continuous Working Voltage	(Note 3)	1000			V_{PEAK}
Maximum Continuous Working Voltage	(Note 3)	690			V_{RMS}
Partial Discharge	$V_{\text{PD}} = 1300V_{\text{PEAK}}$			5	pC
Comparative Tracking Index	IEC 60112 (Note 3)	600			V_{RMS}
Depth of Erosion	IEC 60112 (Note 3)		0.017		mm
Distance Through Insulation	(Note 3)		0.2		mm
Input to Output Resistance	(Note 3)	1	5		$\text{T}\Omega$
Input to Output Capacitance	(Note 3)		5		pF
Creepage Distance	(Note 3)		14.49		mm

LTM2985 EEPROM CHARACTERISTICS

full operating temperature range, otherwise specifications are at $T_A = 25^\circ\text{C}$.

The ● denotes the specifications which apply over the

PARAMETER	CONDITIONS		MIN	TYP	MAX	UNITS
Retention	(Notes 3, 16)	●	10			Years
Endurance	(Note 3)	●	10000			Cycles
Programming Time	Complete Transfer from RAM to EEPROM	●			2600	ms
Read Time	Complete Transfer from EEPROM to RAM	●			20	ms

Note 1: Stresses beyond those listed under Absolute Maximum Ratings may cause permanent damage to the device. Exposure to any Absolute Maximum Rating condition for extended periods may affect device reliability and lifetime.

Note 2: Full scale ADC error. Measurements do not include reference error.

Note 3: Guaranteed by design, not subject to test.

Note 4: The input referred noise includes the contribution of internal calibration operations.

Note 5: MUX configuration delay = default 1ms.

Note 6: Global configuration set to 60Hz rejection.

Note 7: Global configuration set to 50Hz rejection.

Note 8: Global configuration default 50Hz/60Hz rejection.

Note 9: The exact value of V_{REF} is stored in the LTM2985 and used for all measurement calculations. Temperature coefficient is measured by dividing the maximum change in output voltage by the specified temperature range.

Note 10: Analog power-up. Command status register inaccessible during this time.

Note 11: Digital initialization. Begins at the conclusion of analog power-up. Command status register is 0x80 at the beginning of digital initialization and 0x40 at the conclusion.

Note 12: Long-term stability typically has a logarithmic characteristic and therefore, changes after 1000 hours tend to be much smaller than before that time. Total drift in the second thousand hours is normally less than one third that of the first thousand hours with a continuing trend toward reduced drift with time. Long-term stability will also be affected by differential stresses between the IC and the board material created during board assembly.

Note 13: Hysteresis in output voltage is created by package stress that differs depending on whether the IC was previously at a higher or lower temperature. Output voltage is always measured at 25°C , but

the IC is cycled to the hot or cold temperature limit before successive measurements. Hysteresis measures the maximum output change for the averages of three hot or cold temperature cycles. For instruments that are stored at well controlled temperatures (within 20 or 30 degrees of operational temperature), it is usually not a dominant error source. Typical hysteresis is the worst-case of 25°C to cold to 25°C or 25°C to hot to 25°C , preconditioned by one thermal cycle.

Note 14: Differential Input Range is $\pm V_{REF}/2$.

Note 15: RTD and thermistor measurements are made ratiometrically. As a result, current source excitation variation does not affect absolute accuracy. Choose an excitation current such that largest sensor or R_{SENSE} resistance value, when driven by the nominal excitation current, will drop 1V or less. The extended ADC input range will accommodate variation in excitation current and the ratiometric calculation will negate the absolute value of the excitation current.

Note 16: 10-year data retention guaranteed for up to 1000 program cycles.

Note 17: Do not apply voltage or current sources to these pins. They must be connected to capacitive loads only. Otherwise, permanent damage may occur.

Note 18: Input leakage measured with $V_{IN} = -10\text{mV}$ and $V_{IN} = 2.5\text{V}$.

Note 19: This Module includes overtemperature protection that is intended to protect the device during momentary overload conditions. Junction temperature will exceed 125°C when overtemperature protection is active. Continuous operation above specified maximum operating junction temperature may result in device degradation or failure.

Note 20: Device considered a 2-terminal device. Pin group A1 through C11 shorted together and pin group R1 through T11 shorted together.

Note 21: The rated dielectric insulation voltage should not be interpreted as a continuous voltage rating.

TYPICAL PERFORMANCE CHARACTERISTICS

Type J Thermocouple Error and RMS Noise vs Temperature

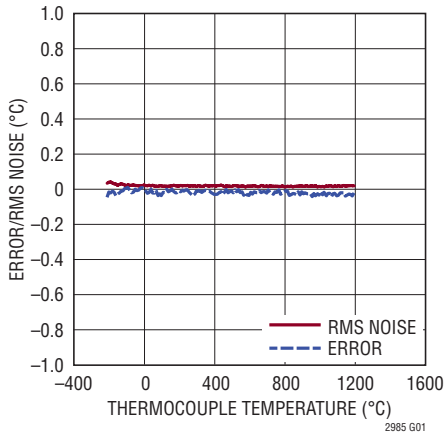

Type K Thermocouple Error and RMS Noise vs Temperature

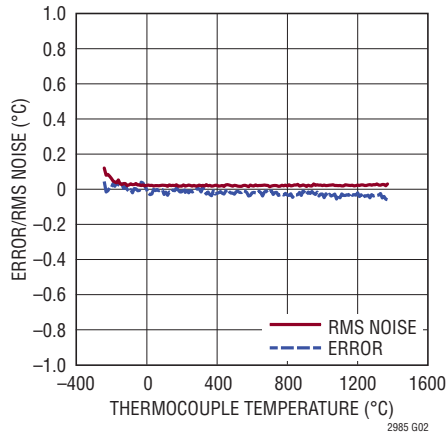

Type N Thermocouple Error and RMS Noise vs Temperature

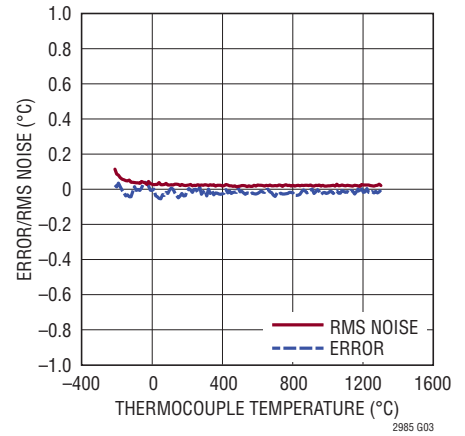

Type R Thermocouple Error and RMS Noise vs Temperature

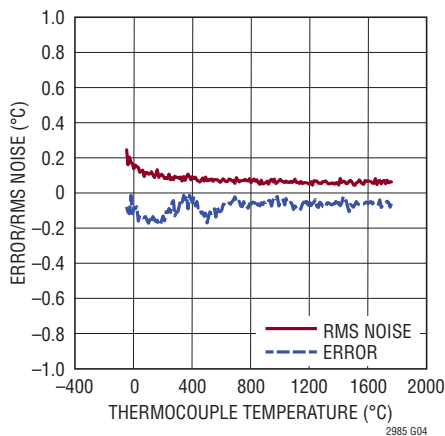

Type S Thermocouple Error and RMS Noise vs Temperature

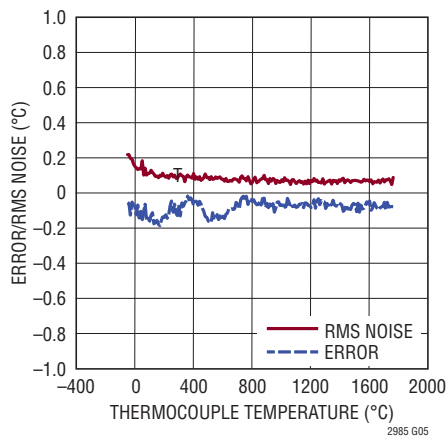

Type T Thermocouple Error and RMS Noise vs Temperature

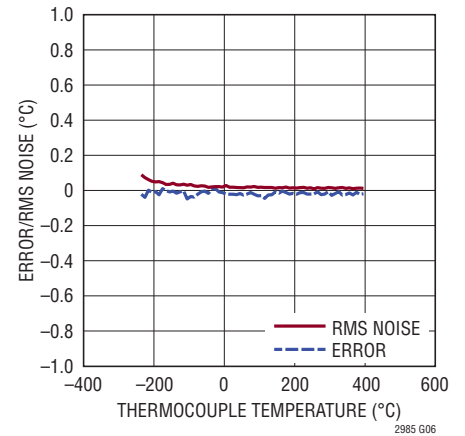

Type E Thermocouple Error and RMS Noise vs Temperature

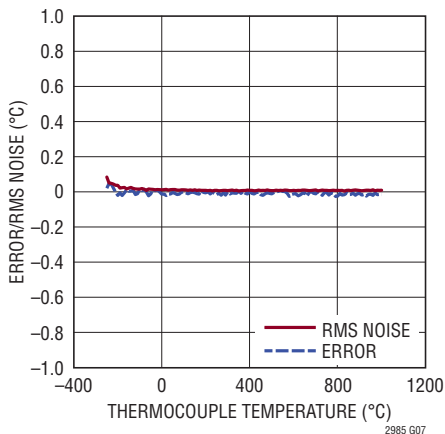

Type B Thermocouple Error and RMS Noise vs Temperature

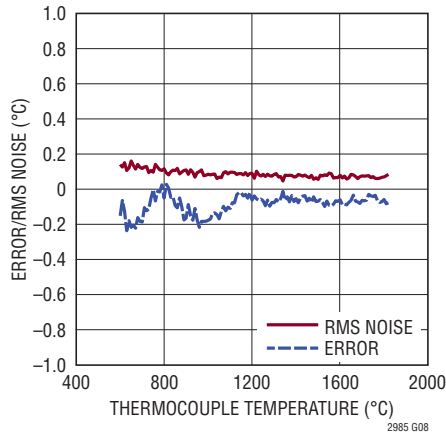

RTD PT-1000 Error and RMS Noise vs Temperature

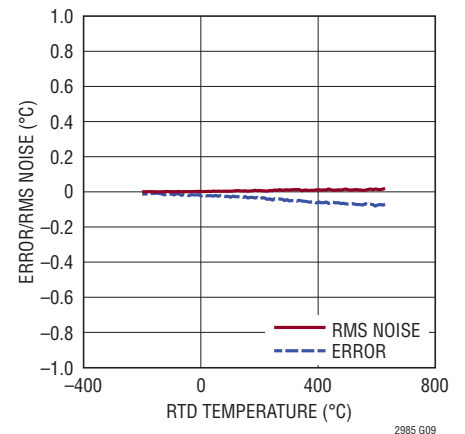

TYPICAL PERFORMANCE CHARACTERISTICS

RTD PT-200 Error and RMS Noise vs Temperature

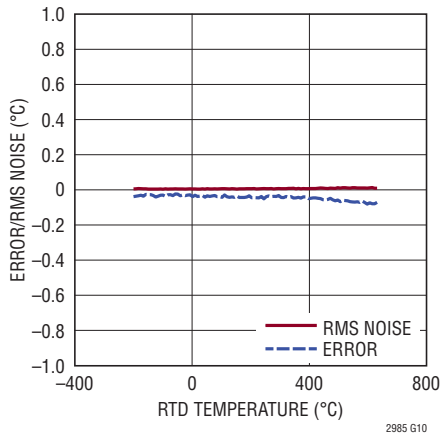

RTD PT-100 Error and RMS Noise vs Temperature

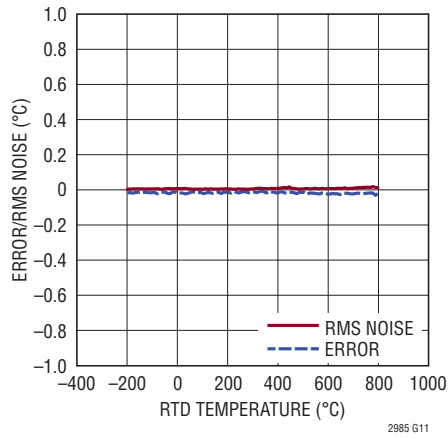

RTD NI-120 RTD Error and RMS Noise vs Temperature

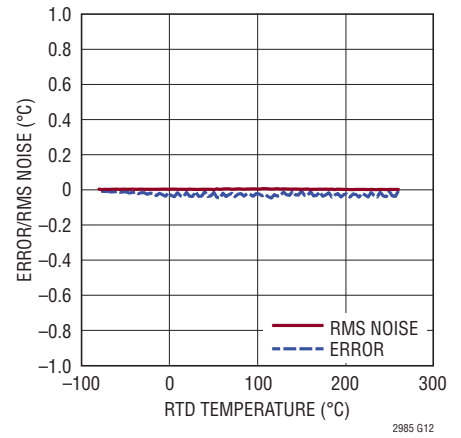

2.252k Thermistor Error vs Temperature

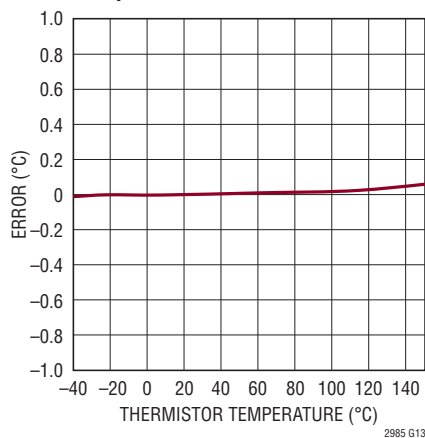

3k Thermistor Error vs Temperature

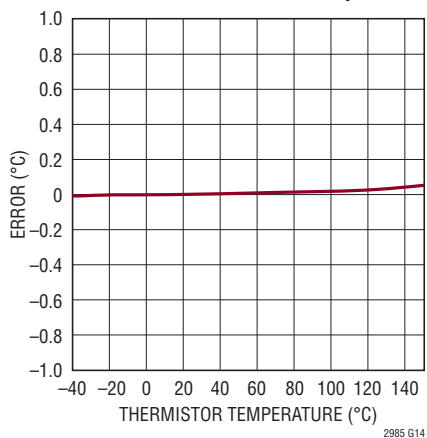

5k Thermistor Error vs Temperature

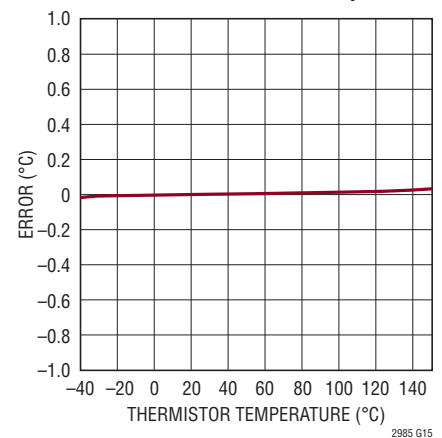

10k Thermistor Error vs Temperature

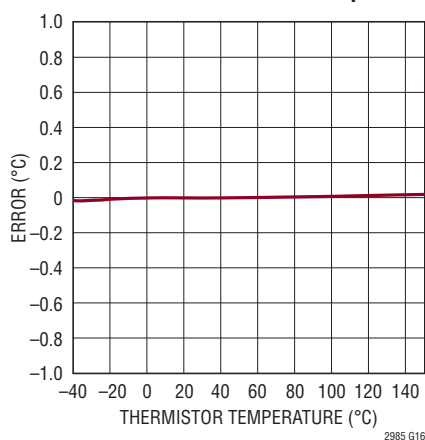

30k Thermistor Error vs Temperature

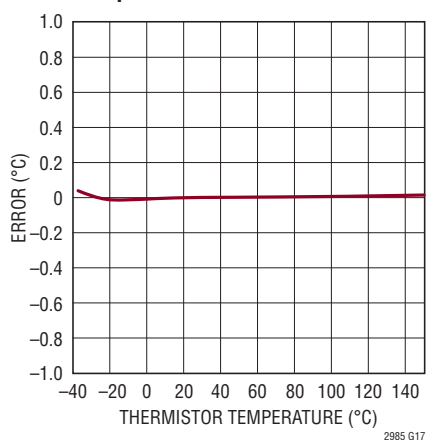

YSI-400 Thermistor Error vs Temperature

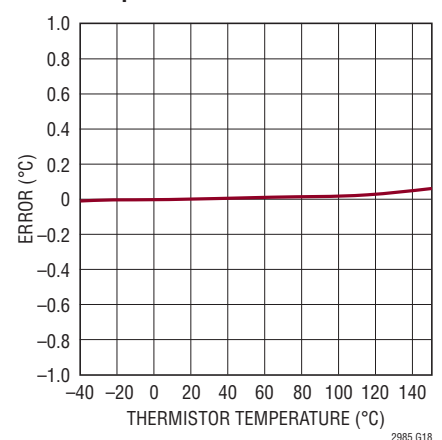

TYPICAL PERFORMANCE CHARACTERISTICS

Diode Error and Repeatability vs Temperature

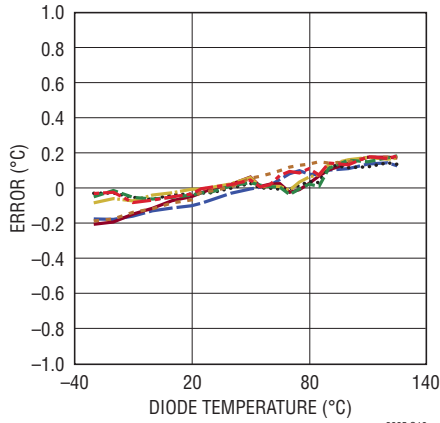

Offset vs Temperature

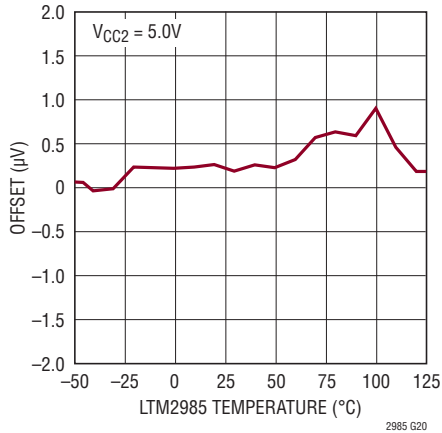

Noise vs Temperature

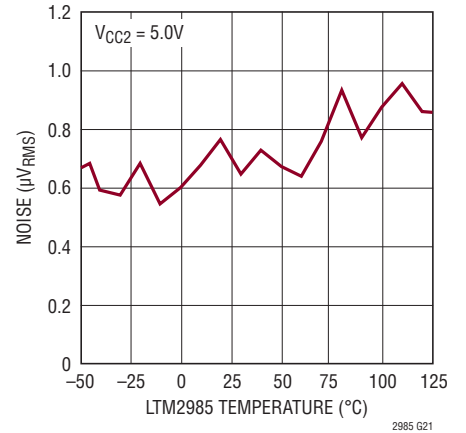

V_{REF} vs Temperature

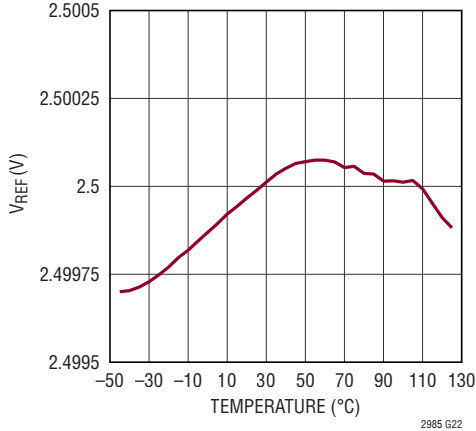

Channel Input Leakage Current vs Temperature

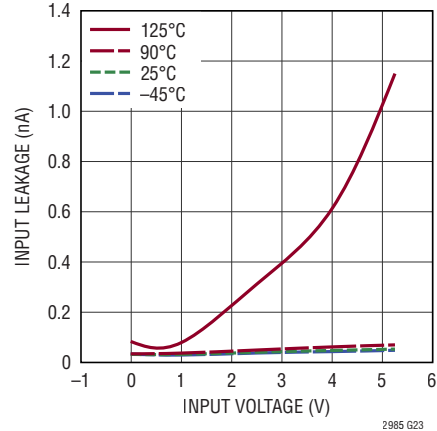

Adjacent Channel Offset Error vs Input Fault Voltage (V_{CC2} = 5V)

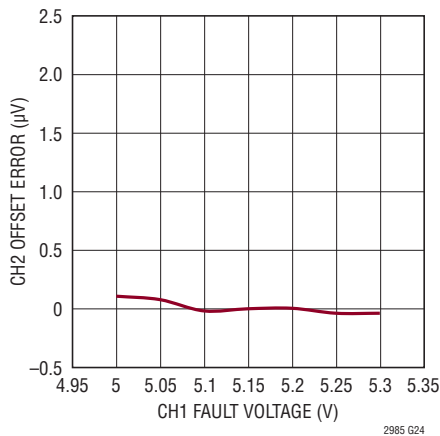

Adjacent Channel Offset Error vs Input Fault Voltage

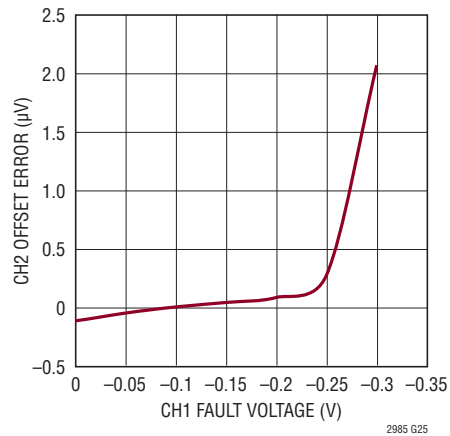

PIN FUNCTIONS

Logic Side

DOUT (B1): Digital Output, Referenced to V_L and GND. Logic output connected to DIN through isolation barrier. Under the condition of an isolation communication failure this output is in a high impedance state.

SDO (A2): Serial SPI Digital Output, Referenced to V_L and GND. Under the condition of an isolation communication failure this output is in a high impedance state.

SCK (A3): Serial SPI Clock Input, Referenced to V_L and GND. Do not float.

SDI (A4): Serial SPI Data Input, Referenced to V_L and GND. Do not float.

\overline{CS} (A5): Serial SPI Chip Select, Referenced to V_L and GND. Do not float.

\overline{SDOE} (A6): Serial SPI Data Output Enable, Referenced to V_L and GND. A logic high on \overline{SDOE} places the logic side SDO pin in a high impedance state, a logic low enables the output. Do not float. For multiple SPI devices on the same bus connect \overline{SDOE} to \overline{CS} , otherwise tie to GND.

ON (A7): Enable. Enables power and data communication through the isolation barrier. If ON is high, the part is enabled and power and communications are functional to the isolated side. If ON is low, the logic side is held in reset, all digital outputs are in a high impedance state and the isolated side is unpowered. Do not float.

V_L (A8, B8): Logic Supply. Interface supply voltage for pins SDI, SCK, SDO, DOUT, \overline{CS} , \overline{SDOE} and ON. Operating voltage is 1.62V to 5.5V. Internally bypassed with 2.2 μ F to GND.

GND (A9, B2 to B7, B9, C1 to C11): Circuit Ground.

V_{CC} (A10, A11, B10, B11): Isolated Analog Power Supply. Internally bypassed with 2.2 μ F to GND.

DNC (A1): Do Not Connect. Pin connected internally.

Isolated Side

V_{CC2} (R11): 5V Nominal Isolated Supply Voltage. Internally generated from V_{CC} by an isolated DC/DC converter and regulated to 5V. Internally bypassed with 2.2 μ F to GND2.

DIN (T3): Digital Input, Referenced to V_{CC2} and GND2. Logic input connected to DOUT through isolation barrier. The logic state on DIN translates to the same logic state on DOUT (Do not float).

INT (T2): Interrupt. Transitions from LOW to HIGH once the conversion is complete. Can be sent to logic side by shorting to DIN.

GND2 (R8, S6, S8, R10, R3, S3, T1): Isolated Ground.

V_{REF} (S11): Reference output pin. Internally bypassed with 10 μ F to GND. Do not load this pin.

DNC (R1, R2, R9, S1, S2, S9, S10, T8, T9, T10, T11): Do Not Connect. Do not connect these pins to external circuitry unless stated otherwise in this data sheet. Note that Ball S9 is LDO and may be used in the thermistor auto range circuit.

CH1–CH10 (R7, R6, R5, R4, S4, T4, T5, T6, T7, S7): Analog Inputs. May be programmed for single-ended, differential, or ratio-metric operation. The voltage on these pins can have any value between GND2 – 50mV and V_{CC2} – 0.3V. Unused pins can be grounded or left floating.

COM (S5): Common input, this is the negative input pin for all single ended operations.

BLOCK DIAGRAM

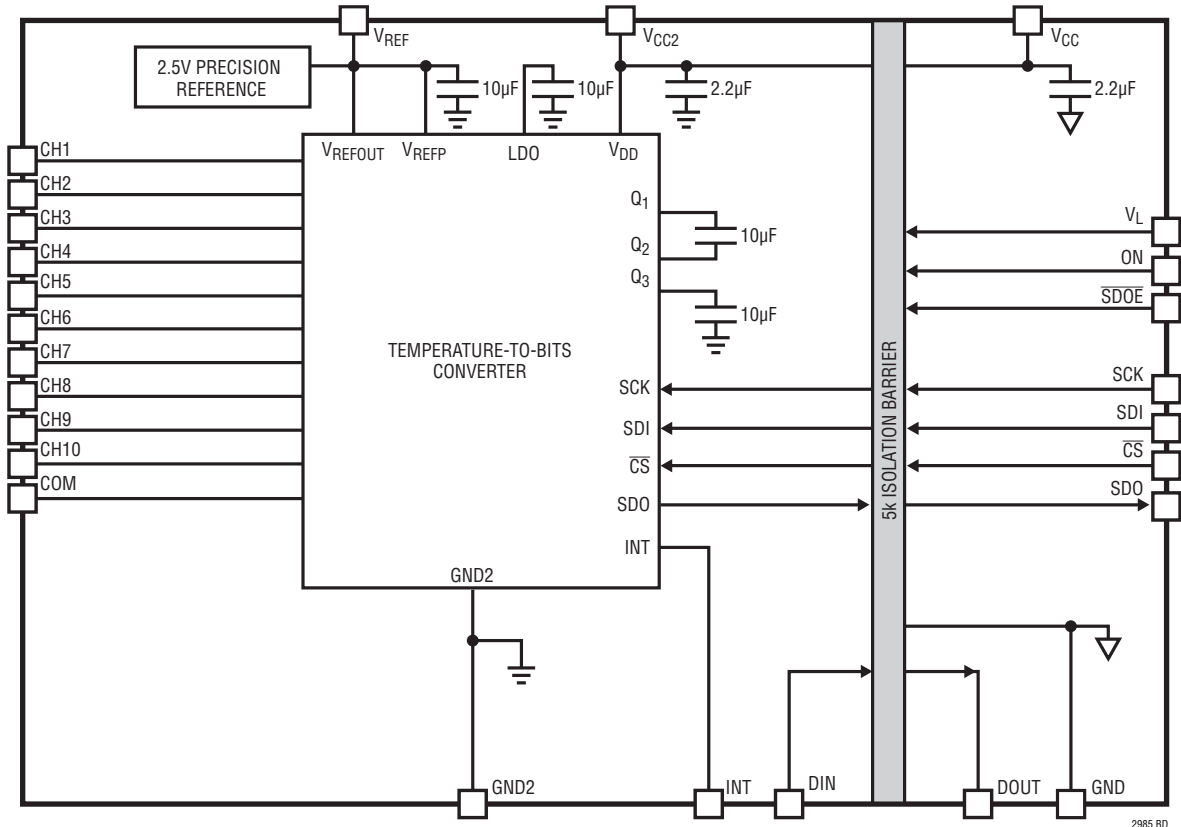

2985 BD

TEST CIRCUITS

Test Circuits for SDO Output Timing

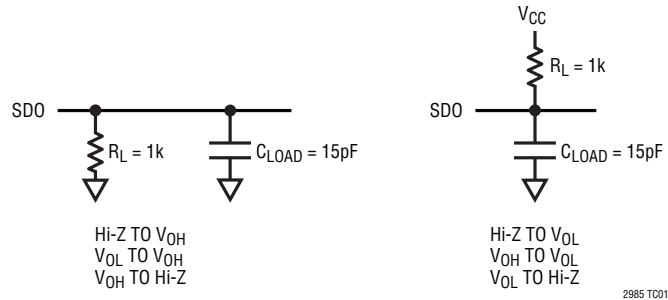

TIMING DIAGRAM

SPI Timing Diagram

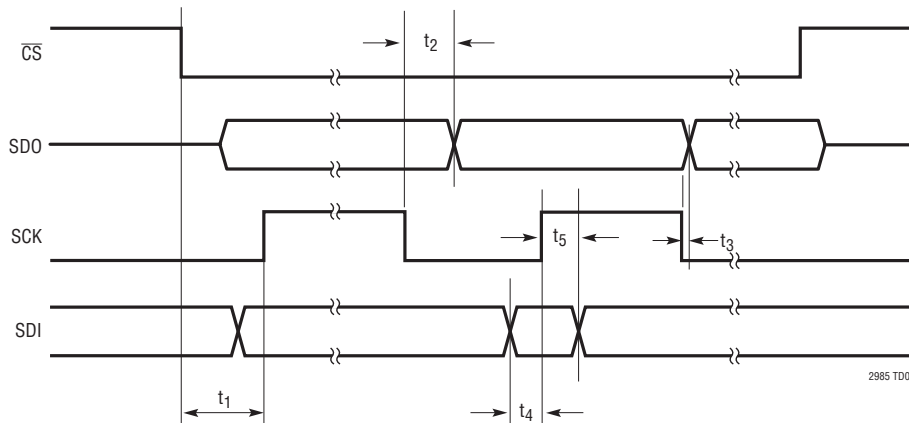

OVERVIEW

The LTM2985 measures the temperature of the most common sensors (thermocouples, RTDs, thermistors, active analog temperature sensors and diodes). It includes all necessary active circuitry, switches, measurement algorithms and mathematical conversions to determine the temperature for each sensor type.

Thermocouples can measure temperatures from as low as -265°C to over 1800°C . Thermocouples generate a voltage as a function of the temperature difference between the tip (thermocouple temperature) and the electrical connection on the circuit board (cold junction temperature). In order to determine the thermocouple temperature, an accurate measurement of the cold junction temperature is required; this is known as cold junction compensation. The cold junction temperature is usually determined by placing a separate (non-thermocouple) temperature sensor at the cold junction. The LTM2985 allows diodes, active analog temperature sensors, RTDs and thermistors to be used as cold junction sensors. In order to convert the voltage output from the thermocouple into a temperature result, a high order polynomial equation (up to 14th order) must be solved. The LTM2985 has these polynomials built in for virtually all standard thermocouples (J, K, N, E, R, S, T and B). Additionally, inverse polynomials must be solved for the cold junction temperature. The LTM2985 simultaneously measures the thermocouple output and the cold junction temperature and performs all required calculations to report the thermocouple temperature in $^{\circ}\text{C}$ or $^{\circ}\text{F}$. It directly digitizes both positive and negative voltages (down to 50mV below ground) from a single ground referenced supply, includes sensor burn-out detection and allows external protection/anti-aliasing circuits without the need of buffer circuits.

Diodes are convenient low cost sensor elements and are often used to measure cold junction temperatures in thermocouple applications. Diodes are typically used to measure temperatures from -60°C to 130°C , which is suitable for most cold junction applications. Diodes generate an output voltage that is a function of temperature and excitation current. When the difference of two diode

output voltages are taken at two different excitation current levels, the result (ΔV_{BE}) is proportional to temperature. The LTM2985 accurately generates excitation currents, measures the diode voltages and calculates the temperature in $^{\circ}\text{C}$ or $^{\circ}\text{F}$.

RTDs and thermistors are resistors that change value as a function of temperature. RTDs can measure temperatures over a wide temperature range, from as low as -200°C to 850°C while thermistors typically operate from -40°C to 150°C . In order to measure one of these devices a precision sense resistor is tied in series with the sensor. An excitation current is applied to the network and a ratiometric measurement is made. The value, in Ω , of the RTD/thermistor can be determined from this ratio. This resistance is used to determine the temperature of the sensor element using a table lookup (RTDs) or solving Steinhart-Hart equations (thermistors). The LTM2985 automatically generates the excitation current, simultaneously measures the sense resistor and thermistor/RTD voltage, calculates the sensor resistance and reports the result in $^{\circ}\text{C}$. The LTM2985 can digitize most RTD types (PT-10, PT-50, PT-100, PT-200, PT-500, PT-1000 and NI-120), has built in coefficients for many curves (American, European, Japanese and ITS-90) and accommodates 2-wire, 3-wire and 4-wire configurations. It also includes coefficients for calculating the temperature of standard 2.252k, 3k, 5k, 10k and 30k thermistors. It can be configured to share one sense resistor among multiple RTDs/thermistors and to rotate excitation current sources to remove parasitic thermal effects. In addition to built-in linearization coefficients, the LTM2985 provides the means of inserting custom coefficients for both RTDs and thermistors.

The LTM2985 includes the capability to measure active analog output temperature sensors. These sensors output voltage as a function of temperature. The relationship between voltage and temperature can be stored in the LTM2985. These sensors can be used as a stand alone temperature sensor or as the cold junction compensation for thermocouple measurements.

OVERVIEW

Table 1 shows the estimated system accuracy and noise associated with specific temperature sensing devices. System accuracy and peak-to-peak noise include the effects of the ADC, internal amplifiers, excitation current sources and integrated reference. Accuracy and noise are the worst-case errors calculated from the guaranteed maximum ADC and reference specifications. Peak-to-peak noise values are calculated at 0°C (except Type B

was calculated at 400°C) and diode measurements use AVG = ON mode.

Thermocouple errors do not include the errors associated with the cold junction measurement. Errors associated with a specific cold junction sensor within the operating temperature range can be combined with the errors for a given thermocouple for total temperature measurement accuracy.

Table 1. LTM2985 Error Contribution and Peak Noise Errors

SENSOR TYPE	TEMPERATURE RANGE	ERROR CONTRIBUTION	PEAK-TO-PEAK NOISE
Type K Thermocouple	–200°C to 0°C 0°C to 1372°C	$\pm(\text{Temperature} \cdot 0.23\% + 0.05)^\circ\text{C}$ $\pm(\text{Temperature} \cdot 0.12\% + 0.05)^\circ\text{C}$	$\pm 0.08^\circ\text{C}$
Type J Thermocouple	–210°C to 0°C 0°C to 1200°C	$\pm(\text{Temperature} \cdot 0.23\% + 0.05)^\circ\text{C}$ $\pm(\text{Temperature} \cdot 0.12\% + 0.05)^\circ\text{C}$	$\pm 0.07^\circ\text{C}$
Type E Thermocouple	–200°C to 0°C 0°C to 1000°C	$\pm(\text{Temperature} \cdot 0.18\% + 0.05)^\circ\text{C}$ $\pm(\text{Temperature} \cdot 0.10\% + 0.05)^\circ\text{C}$	$\pm 0.06^\circ\text{C}$
Type N Thermocouple	–200°C to 0°C 0°C to 1300°C	$\pm(\text{Temperature} \cdot 0.27\% + 0.08)^\circ\text{C}$ $\pm(\text{Temperature} \cdot 0.10\% + 0.08)^\circ\text{C}$	$\pm 0.13^\circ\text{C}$
Type R Thermocouple	0°C to 1768°C	$\pm(\text{Temperature} \cdot 0.10\% + 0.4)^\circ\text{C}$	$\pm 0.62^\circ\text{C}$
Type S Thermocouple	0°C to 1768°C	$\pm(\text{Temperature} \cdot 0.10\% + 0.4)^\circ\text{C}$	$\pm 0.62^\circ\text{C}$
Type B Thermocouple	400°C to 1820°C	$\pm(\text{Temperature} \cdot 0.10\%)^\circ\text{C}$	$\pm 0.83^\circ\text{C}$
Type T Thermocouple	–250°C to 0°C 0°C to 400°C	$\pm(\text{Temperature} \cdot 0.15\% + 0.05)^\circ\text{C}$ $\pm(\text{Temperature} \cdot 0.10\% + 0.05)^\circ\text{C}$	$\pm 0.09^\circ\text{C}$
External Diode (2 Reading)	–40°C to 85°C	$\pm 0.25^\circ\text{C}$	$\pm 0.05^\circ\text{C}$
External Diode (3 Reading)	–40°C to 85°C	$\pm 0.25^\circ\text{C}$	$\pm 0.2^\circ\text{C}$
Platinum RTD – PT-10, $R_{\text{SENSE}} = 1\text{k}\Omega$	–200°C to 800°C	$\pm 0.1^\circ\text{C}$	$\pm 0.05^\circ\text{C}$
Platinum RTD – PT-100, $R_{\text{SENSE}} = 2\text{k}\Omega$	–200°C to 800°C	$\pm 0.1^\circ\text{C}$	$\pm 0.05^\circ\text{C}$
Platinum RTD – PT-500, $R_{\text{SENSE}} = 2\text{k}\Omega$	–200°C to 800°C	$\pm 0.1^\circ\text{C}$	$\pm 0.02^\circ\text{C}$
Platinum RTD – PT-1000, $R_{\text{SENSE}} = 2\text{k}\Omega$	–200°C to 800°C	$\pm 0.1^\circ\text{C}$	$\pm 0.01^\circ\text{C}$
Thermistor, $R_{\text{SENSE}} = 10\text{k}\Omega$	–40°C to 85°C	$\pm 0.1^\circ\text{C}$	$\pm 0.01^\circ\text{C}$

OVERVIEW

Memory Map

The LTM2985 channel assignment, configuration, conversion start and results are all accessible via the RAM (see Table 2A). Table 2B details the valid SPI instruction bytes for accessing memory. The channel conversion results are mapped into memory locations 0x010 to 0x037 and can be read using the SPI interface as shown in Figure 1. A read is initiated by sending the read instruction byte = 0x03

followed by the address and then data. Channel assignment data resides in memory locations 0x200 to 0x227 and can be programmed via the SPI interface as shown in Figure 2. A write is initiated by sending the write instruction byte = 0x02 followed by the address and then data. Conversions are initiated by writing the conversion control byte (see Table 6) into memory location 0x000 (command status register).

Table 2A. Memory Map

LTM2985 MEMORY MAP				
SEGMENT	START ADDRESS	END ADDRESS	SIZE (BYTES)	DESCRIPTION
Command Status Register	0x000	0x0000	1	See Table 6 and Table 12, Initiate Conversion, Sleep Command, EEPROM Command
Reserved	0x001	0x000F	15	
Temperature Result Memory 10 Words – 40 Bytes	0x010	0x037	40	See Tables 8 to 10, Read Result
Reserved	0x038	0x0AF	120	
EEPROM Key	0x0B0	0x0B3	4	See Table 11
Reserved	0x0B4	0x0CF	44	
EEPROM Read Result Code	0x0D0	0x0D0	1	See Table 11
Reserved	0x0D1	0x0EF	15	
Global Configuration Register	0x0F0	0x0F0	1	See Table 67 for Global Configuration
Reserved	0x0F1	0x0F3	3	
Measure Multiple Channels Bit Mask	0x0F4	0x0F7	4	See Tables 84, 85, Run Multiple Conversions
Reserved	0x0F8	0x0F8	1	
EEPROM Status Register	0x0F9	0x0F9	1	See Table 13
Reserved	0x0FA	0x0FE	5	
MUX Configuration Delay	0x0FF	0x0FF	1	See MUX Configuration Delay Section of Data Sheet
Reserved	0x100	0x1FF	256	
Channel Assignment Data	0x200	0x227	40	See Table 3 and Table 4, Channel Assignment
Reserved	0x228	0x24F	40	
Custom Sensor Table Data	0x250	0x3CF	384	
Reserved	0x3D0	0x3FF	48	

Table 2B. SPI Instruction Byte

INSTRUCTION	SPI INSTRUCTION BYTE	DESCRIPTION
Read	0b00000011	See Figure 1
Write	0b00000010	See Figure 2
Invalid	0bxxxxxx0x	

OVERVIEW

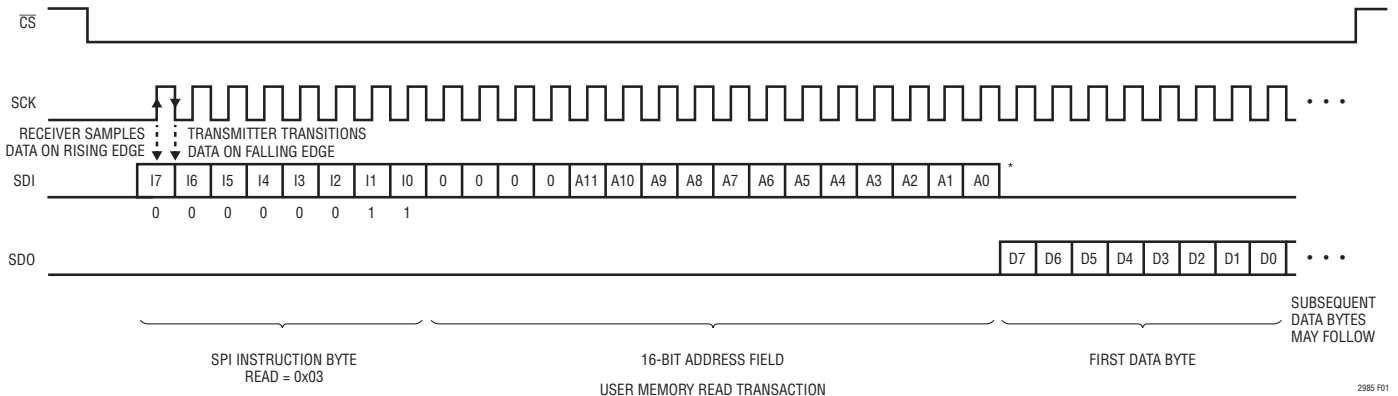

Figure 1. Memory Read Operation

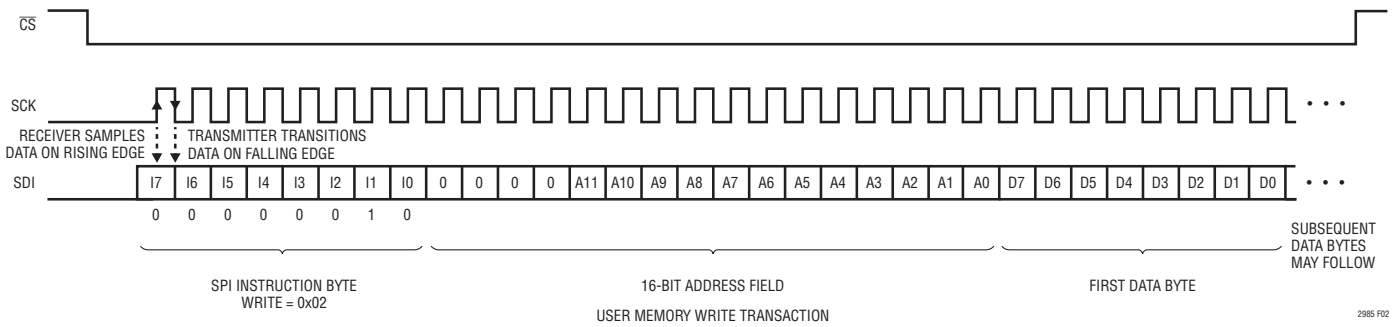

Figure 2. Memory Write Operation

APPLICATIONS INFORMATION

The LTM2985 combines high accuracy with ease of use. The basic operation is simple and is composed of five states (see Figure 3).

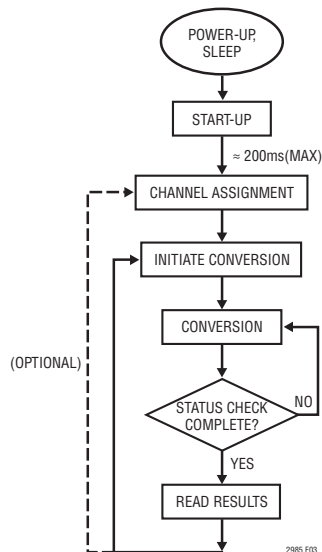

Figure 3. Basic Operation

Conversion States Overview

- 1. Start-Up.** After power is applied to the LTM2985 ($V_{CC2} > 2.6V$), there is a 200ms wake up period. During this time, the LDO, charge pump, ADCs and reference are powered up and the internal RAM is initialized. Once start-up is complete, the INT pin goes HIGH and the command status register will return a value of 0x40 (Start bit = 0, Done bit = 1) when read.
- 2. Channel Assignment.** The device automatically enters the channel assignment state after start-up is complete. While in this state, the user writes sensor specific data for each input channel into RAM. The user can also load it from the EEPROM (see the EEPROM section for more details). The assignment data contains information about the sensor type, pointers to cold junction sensors or sense resistors and sensor specific parameters.
- 3. Initiate Conversion.** A conversion is initiated by writing a measurement command into RAM memory location 0x000. This command is a pointer to the channel in which the conversion will be performed.

4. Conversion. A new conversion begins automatically following an Initiate Conversion command. In this state, the ADC is running a conversion on the specified channel and associated cold junction or R_{SENSE} channel (if applicable). The user is locked out of RAM access while in the state (except for reading status location 0x000). The end of conversion is indicated by both the INT pin going HIGH and a status register START bit going LOW and DONE bit going HIGH.

5. Read Results. In this state, the user has access to RAM and can read the completed conversion results and fault status bits. It is also possible for the user to modify/append the channel assignment data during the read results state.

Conversion State Details

State 1: Start-Up

The start-up state automatically occurs when power is applied to the LTM2985. If the power drops below a threshold of $\approx 2.6V$ and then returns to the normal operating voltage (2.85V to 5.25V), the LTM2985 resets and enters the power-up state. Note that the LTM2985 also enters the start-up state at the conclusion of the sleep state.

In the first phase of the start-up state all critical analog circuits are powered up. This includes the LDO, reference, charge pump and ADCs. During this first phase, the command status register will be inaccessible to the user. This phase takes a maximum of 100ms to complete. Once this phase completes, the command status register will be accessible and return a value of 0x80 until the LTM2985 is completely initialized. Once the LTM2985 is initialized and ready to use, the INT pin will go high and the command status register will return a read value of 0x40 (Start bit = 0, Done bit = 1). At this point the LTM2985 is fully initialized and is ready to perform a conversion.

State 2: Channel Assignment

The LTM2985 RAM can be programmed with up to 10 sets of 32-bit (4-byte) channel assignment data. These reside sequentially in RAM with a one-to-one correspondence to each of the 10 analog input channels (see Table 3). Channels that are not used should have their channel assignment data set to all zeros (default at START-UP).

APPLICATIONS INFORMATION

Table 3. Channel Assignment Memory Map

CHANNEL ASSIGNMENT NUMBER	CONFIGURATION DATA START ADDRESS	CONFIGURATION DATA ADDRESS + 1	CONFIGURATION DATA ADDRESS + 2	CONFIGURATION DATA END ADDRESS + 3	SIZE (BYTES)
CH1	0x200	0x201	0x202	0x203	4
CH2	0x204	0x205	0x206	0x207	4
CH3	0x208	0x209	0x20A	0x20B	4
CH4	0x20C	0x20D	0x20E	0x20F	4
CH5	0x210	0x211	0x212	0x213	4
CH6	0x214	0x215	0x216	0x217	4
CH7	0x218	0x219	0x21A	0x21B	4
CH8	0x21C	0x21D	0x21E	0x21F	4
CH9	0x220	0x221	0x222	0x223	4
CH10	0x224	0x225	0x226	0x227	4

APPLICATIONS INFORMATION

The channel assignment data contains all the necessary information associated with the specific sensor tied to that channel (see Table 4). The first five bits determine the sensor type (see Table 5). Associated with each sensor are sensor specific configurations. These include pointers to cold junction or sense resistor channels, pointers to memory locations of custom linearization data, sense resistor values and diode ideality factors. Also included in this data are, if applicable, the excitation current level,

single-ended/differential input mode, as well as sensor specific controls. Separate detailed operation sections for thermocouples, RTDs, diodes, thermistors, analog temperature sensors and sense resistors describe the assignment data associated with each sensor type in more detail. The LTM2985 demonstration software includes a utility for checking configuration data and generating annotated C-code for programming the channel assignment data.

Table 4. Channel Assignment Data

Channel Assignment Memory Location	SENSOR TYPE					SENSOR SPECIFIC CONFIGURATION																									
	Configuration Data Start Address					Configuration Data Start Address + 1						Configuration Data Start Address + 2				Configuration Data Start Address + 3															
	31	30	29	28	27	26	25	24	23	22	21	20	19	18	17	16	15	14	13	12	11	10	9	8	7	6	5	4	3	2	1
Unassigned (Default)	Type = 0					Channel Disabled																									
Thermocouple	Type = 1 to 9					Cold Junction Channel Assignment [4:0]				SGL=1 DIFF=0	OC Check	OC Current [1:0]		0	0	0	0	0	0	Custom Address [5:0]		Custom Length – 1 [5:0]									
RTD	Type = 10 to 18					R _{SENSE} Channel Assignment [4:0]				2, 3, 4 Wire		Excitation Mode		Excitation Current [3:0]		Curve [1:0]		Custom Address [5:0]		Custom Length – 1 [5:0]											
Thermistor	Type = 19 to 27					R _{SENSE} Channel Assignment [4:0]				SGL=1 DIFF=0	Excitation Mode		Excitation Current [3:0]		0	0	0	Custom Address [5:0]		Custom Length – 1 [5:0]											
Diode	Type = 28					SGL=1 DIFF=0		2 to 3 Reading	Avg on	Current [1:0]	Ideality Factor (2, 20) Value from 0 to 4 with 1/1048576 Resolution All Zeros Use Factory Set Default in ROM																				
Sense Resistor	Type = 29					Sense Resistor Value (17, 10) Up to 131,072Ω with 1/1024Ω Resolution																									
Direct ADC	Type = 30					SGL=1 DIFF=0	Table Mode	Not Used									Custom Address [5:0]		Custom Length – 1 [5:0]												
Active Analog Temperature Sensor	Type = 31					SGL=1 DIFF=0	Not Used									Custom Address [5:0]		Custom Length – 1 [5:0]													

APPLICATIONS INFORMATION

Table 5. Sensor Type Selection

31	30	29	28	27	SENSOR TYPE
0	0	0	0	0	Unassigned
0	0	0	0	1	Type J Thermocouple
0	0	0	1	0	Type K Thermocouple
0	0	0	1	1	Type E Thermocouple
0	0	1	0	0	Type N Thermocouple
0	0	1	0	1	Type R Thermocouple
0	0	1	1	0	Type S Thermocouple
0	0	1	1	1	Type T Thermocouple
0	1	0	0	0	Type B Thermocouple
0	1	0	0	1	Custom Thermocouple
0	1	0	1	0	RTD PT-10
0	1	0	1	1	RTD PT-50
0	1	1	0	0	RTD PT-100
0	1	1	0	1	RTD PT-200
0	1	1	1	0	RTD PT-500
0	1	1	1	1	RTD PT-1000
1	0	0	0	0	RTD 1000 (0.00375)
1	0	0	0	1	RTD NI-120
1	0	0	1	0	RTD Custom
1	0	0	1	1	Thermistor 44004/44033 2.252k Ω at 25°C
1	0	1	0	0	Thermistor 44005/44030 3k Ω at 25°C
1	0	1	0	1	Thermistor 44007/44034 5k Ω at 25°C
1	0	1	1	0	Thermistor 44006/44031 10k Ω at 25°C
1	0	1	1	1	Thermistor 44008/44032 30k Ω at 25°C
1	1	0	0	0	Thermistor YSI 400 2.252k Ω at 25°C
1	1	0	0	1	Thermistor Spectrum 1003k 1k Ω
1	1	0	1	0	Thermistor Custom Steinhart-Hart
1	1	0	1	1	Thermistor Custom Table
1	1	1	0	0	Diode
1	1	1	0	1	Sense Resistor
1	1	1	1	0	Direct ADC
1	1	1	1	1	Analog Temperature Sensor

State 3: Initiate Conversion

Once the channel assignment is complete, the device is ready to begin a conversion. A conversion is initiated by writing Start (B7 = 1) and Done (B6 = 0) followed by the desired input channel (B4 – B0) into RAM memory location 0x000 (see Tables 6 and 7). It is possible to initiate a measurement cycle on multiple channels by setting the channel selection bits (B4 to B0) to 00000; see the Running Conversions Consecutively on Multiple Channels section of the data sheet.

Table 6. Command Status Register

B7	B6	B5	B4	B3	B2	B1	B0	
Start = 1	Done = 0	0	EEPROM Command and Channel Selection 1 to 10				Start Conversion	
1	0	0	1	0	1	1	1	Initiate Sleep

Table 7. Input Channel Mapping

B7	B6	B5	B4	B3	B2	B1	B0	CHANNEL SELECTED
1	0	0	0	0	0	0	0	Multiple Channels
1	0	0	0	0	0	0	1	CH1
1	0	0	0	0	0	1	0	CH2
1	0	0	0	0	0	1	1	CH3
1	0	0	0	0	1	0	0	CH4
1	0	0	0	0	1	0	1	CH5
1	0	0	0	0	1	1	0	CH6
1	0	0	0	0	1	1	1	CH7
1	0	0	0	1	0	0	0	CH8
1	0	0	0	1	0	0	1	CH9
1	0	0	0	1	0	1	0	CH10
1	0	0	1	0	1	1	1	Sleep
All Other Combinations								Reserved

APPLICATIONS INFORMATION

Bits B4 to B0 determine which input channel the conversion is performed upon and are simply the binary equivalent of the channel number (see Table 7). These bits are also used for EEPROM read and write operations (see Table 12).

Bit B5 should be set to 0.

Bits B7 and B6 serve as start/done bits. In order to start a conversion, these bits must be set to “10” (B7=1 and B6=0). When the conversion begins, the INT pin goes LOW. Once the conversion is complete, bits B7 and B6 will toggle to “01” (B7=0 and B6=1) (Address = 0x000) and the INT pin will go HIGH, indicating the conversion is complete and the result is available.

State 4: Conversion

The measurement cycle starts after the Initiate Conversion command is written into RAM location 0x000 (Table 6). The LTM2985 simultaneously measures the selected input sensor, sense resistors (RTDs and thermistors) and cold junction temperatures if applicable (thermocouples).

Once the conversion is started, the user is locked out of the RAM, with the exception of reading status data stored in RAM memory location 0x000.

Once the conversion is started the INT pin goes low. Depending on the sensor configuration, two or three 82ms cycles are required per temperature result. These correspond to conversion rates of 167ms and 251ms, respectively (assuming a filter frequency setting of 55Hz). Details describing these modes are described in the 2- and 3-cycle Conversion Modes section of the data sheet.

The end of conversion can be monitored either through the INT pin (LOW to HIGH transition), or by reading the command status register in RAM memory location 0x000 (start bit, B7, toggles from 1 to 0 and DONE bit, B6, toggles from 0 to 1).

State 5: Read Results

Once the conversion is complete, the conversion results can be read from RAM memory locations corresponding to the input channel (see Table 8).

The conversion result is 32 bits long and contains both the sensor temperature (D23 to D0) and sensor fault data (D31 to D24) (see Tables 9A and 9B).

The result is reported in °C for all temperature sensors with a range of -273.15°C to 8192°C and $1/1024^{\circ}\text{C}$ resolution or in °F with a range of -459.67°F to 8192°F with $1/1024^{\circ}\text{F}$ resolution. Included with the conversion result are seven sensor fault bits and a valid bit. These sensor fault bits are set to a 1 if there was a problem associated with the corresponding conversion result (see Table 10). Two types of errors are reported: hard errors and soft errors. Hard errors indicate the reading is invalid and the resulting temperature reported is -999°C or °F. Soft errors indicate operation beyond the normal temperature range of the sensor or the input range of the ADC. In this case, the calculated temperature is reported but the accuracy may be compromised. Details relating to each fault type are sensor specific and are described in detail in the sensor specific sections of this data sheet. Bit D24 is the valid bit and will be set to a 1 for valid data.

Once the data read is complete, the device is ready for a new Initiate Conversion command. In cases where new channel configuration data is required, the user has access to the RAM in order to modify existing channel assignment data.

Table 8. Conversion Result Memory Map

CONVERSION CHANNEL	START ADDRESS	END ADDRESS	SIZE (BYTES)
CH1	0x010	0x013	4
CH2	0x014	0x017	4
CH3	0x018	0x01B	4
CH4	0x01C	0x01F	4
CH5	0x020	0x023	4
CH6	0x024	0x027	4
CH7	0x028	0x02B	4
CH8	0x02C	0x02F	4
CH9	0x030	0x033	4
CH10	0x034	0x037	4

APPLICATIONS INFORMATION

Table 9A. Example Data Output Words (°C)

	START ADDRESS								START ADDRESS + 1								START ADDRESS + 2								START ADDRESS + 3 (END ADDRESS)										
	D31	D30	D29	D28	D27	D26	D25	D24	D23	D22	D21	D20	D19	D18	D17	D16	D15	D14	D13	D12	D11	D10	D9	D8	D7	D6	D5	D4	D3	D2	D1	D0			
	Fault Data								SIGN MSB																								LSB		
Temperature	Sensor Hard Fault	ADC Hard Fault	CJ Hard Fault	CJ Soft Fault	Sensor Over Range Fault	Sensor Under Range Fault	ADC Out of Range Fault	Valid If 1	4096°C ↓								1°C ↓								1/1024°C ↓										
8191.999°C								1	0	1	1	1	1	1	1	1	1	1	1	1	1	1	1	1	1	1	1	1	1	1	1				
1024°C								1	0	0	0	0	1	0	0	0	0	0	0	0	0	0	0	0	0	0	0	0	0	0	0	0			
1°C								1	0	0	0	0	0	0	0	0	0	0	0	0	0	0	1	0	0	0	0	0	0	0	0	0			
1/1024°C								1	0	0	0	0	0	0	0	0	0	0	0	0	0	0	0	0	0	0	0	0	0	0	0	1			
0°C								1	0	0	0	0	0	0	0	0	0	0	0	0	0	0	0	0	0	0	0	0	0	0	0	0			
-1/1024°C								1	1	1	1	1	1	1	1	1	1	1	1	1	1	1	1	1	1	1	1	1	1	1	1	1			
-1°C								1	1	1	1	1	1	1	1	1	1	1	1	1	1	1	0	0	0	0	0	0	0	0	0	0			
-273.15°C								1	1	1	1	1	1	0	1	1	1	0	1	1	1	0	1	1	0	1	1	0	0	1	1	1			

Table 9B. Example Data Output Words (°F)

	START ADDRESS								START ADDRESS + 1								START ADDRESS + 2								START ADDRESS + 3 (END ADDRESS)										
	D31	D30	D29	D28	D27	D26	D25	D24	D23	D22	D21	D20	D19	D18	D17	D16	D15	D14	D13	D12	D11	D10	D9	D8	D7	D6	D5	D4	D3	D2	D1	D0			
	Fault Data								SIGN MSB																								LSB		
Temperature	Sensor Hard Fault	ADC Hard Fault	CJ Hard Fault	CJ Soft Fault	Sensor Over Range Fault	Sensor Under Range Fault	ADC Out of Range Fault	Valid If 1	4096°F ↓								1°F ↓								1/1024°F ↓										
8191.999°F								1	0	1	1	1	1	1	1	1	1	1	1	1	1	1	1	1	1	1	1	1	1	1	1				
1024°F								1	0	0	0	0	1	0	0	0	0	0	0	0	0	0	0	0	0	0	0	0	0	0	0	0			
1°F								1	0	0	0	0	0	0	0	0	0	0	0	0	0	0	1	0	0	0	0	0	0	0	0	0			
1/1024°F								1	0	0	0	0	0	0	0	0	0	0	0	0	0	0	0	0	0	0	0	0	0	0	0	1			
0°F								1	0	0	0	0	0	0	0	0	0	0	0	0	0	0	0	0	0	0	0	0	0	0	0	0			
-1/1024°F								1	1	1	1	1	1	1	1	1	1	1	1	1	1	1	1	1	1	1	1	1	1	1	1	1			
-1°F								1	1	1	1	1	1	1	1	1	1	1	1	1	1	1	0	0	0	0	0	0	0	0	0	0			
-459.67°F								1	1	1	1	1	1	0	0	0	1	1	0	1	0	0	0	1	0	1	0	1	0	0	1	0			

Table 10. Sensor Fault Reporting

BIT	FAULT	ERROR TYPE	DESCRIPTION	OUTPUT RESULT
D31	Sensor Hard Fault	Hard	Bad Sensor Reading	-999°C or °F
D30	Hard ADC-Out-of-Range	Hard	Bad ADC Reading (Could Be Large External Noise Event)	-999°C or °F
D29	CJ Hard Fault	Hard	Cold Junction Sensor Has a Hard Fault Error	-999°C or °F
D28	CJ Soft Fault	Soft	Cold Junction Sensor Result Is Beyond Normal Range	Suspect Reading
D27	Sensor Over Range	Soft	Sensor Reading Is Above Normal Range	Suspect Reading
D26	Sensor Under Range	Soft	Sensor Reading Is Below Normal Range	Suspect Reading
D25	ADC Out-of-Range	Soft	ADC Absolute Input Voltage Is Beyond $\pm 1.125 \cdot V_{REF}/2$	Suspect Reading
D24	Valid	NA	Result Valid (Should Be 1) Discard Results if 0	Suspect Reading

APPLICATIONS INFORMATION

EEPROM OVERVIEW

The LTM2985 contains 512 bytes of EEPROM, which shadows the upper sensor configuration segment of USER RAM (locations 0x200–0x3CF, see Figure 4). Prior to initial usage, the user programs the USER RAM with all channel assignment and custom sensor data. Once the USER RAM has been programmed, the user can save this segment of memory into the EEPROM. After subsequent power down or sleep cycles, the user can reload the USER RAM with this stored EEPROM data bypassing the channel assignment and customer sensor programming normally required.

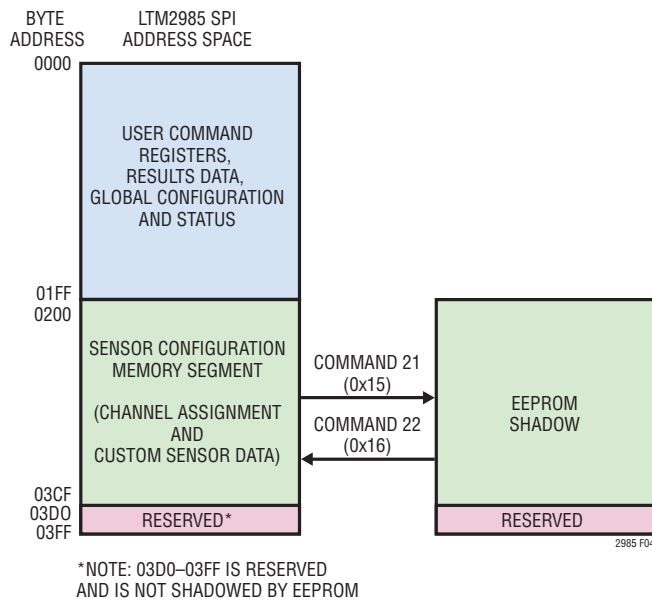

Figure 4. Shadow EEPROM Memory Map

EEPROM READ/WRITE VALIDATION

Access to the EEPROM is key-protected to prevent inadvertent access. The EEPROM also has two levels of data integrity protection. The first level is implemented using an error correcting code (ECC) on each 32-bit word of data in the EEPROM. The ECC is capable of correcting any single bit error per word and detecting 2-bit errors per word. The second level of protection is implemented using a 32-bit checksum, which covers the entire contents of user EEPROM. Status bits are available to the user for reporting ECC status and checksum error conditions.

EEPROM WRITE OPERATION

The EEPROM write operation requires 5 states (see Figure 5).

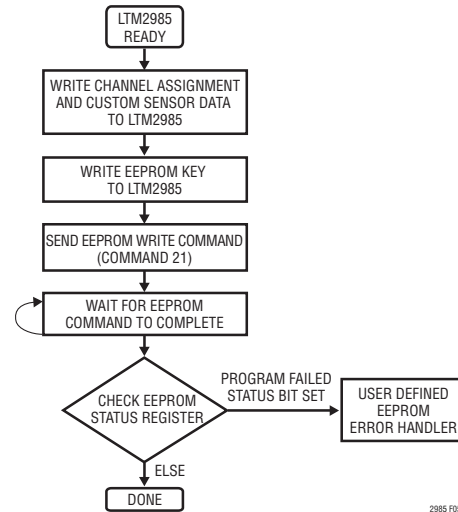

Figure 5. EEPROM Write Operation

- Sensor Configuration.** Write all desired channel assignment and custom sensor data to the LTM2985 USER RAM.
- Set EEPROM Key.** Write the EEPROM Key (0xA53C0F5A) to the key register space of the LTM2985 USER RAM (Address range 0x0B0–0x0B3, see Table 11). Note the key is written MSB first.
- Send EEPROM Write Command.** Write the EEPROM write command (0x15) and start bit (0x80) to the LTM2985 command register (Address 0x000). The command plus start bit is $0x80 + 0x15 = 0x95$ (see Table 12).
- Wait for EEPROM Command to Complete.** Completion of the write operation is indicated by both the INT pin going HIGH and the status register START bit going LOW and DONE bit going HIGH.
- Check EEPROM Status Register.** Read EEPROM Status register (Address 0x0F9) and checks the Program-Failed status bit (Bit 2) to determine whether the EEPROM write operation was successful (see Table 13). The Program-Failed status bit being set indicates that the write operation failed.

Upon successful completion of steps 1–5, the EEPROM will now contain the image that was present in USER RAM locations 0x200–0x3CF.

APPLICATIONS INFORMATION

EEPROM READ OPERATION

The LTM2985 EEPROM read operation is comprised of 4 states (see Figure 6)

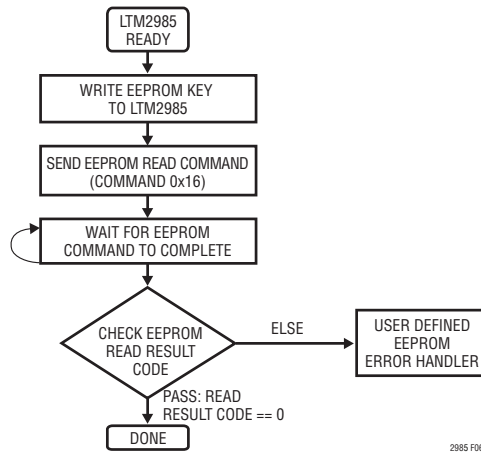

Figure 6. Read Operation

- Set EEPROM Key.** Write the EEPROM Key (0xA53C0F5A) to the key register space of the LTM2985 USER RAM (Address range 0x0B0–0x0B3, see Table 11). Note the key is written MSB first.
- Send EEPROM Read Command.** Write the EEPROM read command (0x16) and start bit (0x80) to the LTM2985 command register (Address 0x000). The command plus start bit would be $0x80 + 0x16 = 0x96$ (see Table 12).
- Wait for EEPROM Command to Complete.** Completion of the read operation is indicated by both the INT pin going HIGH and the status register START bit going LOW and DONE bit going HIGH.
- Check EEPROM Read Result Code.** Read the EEPROM read result code register address (0x0D0) to determine the pass/fail status of the read operation. A value of zero indicates that the command completed successfully and a non-zero value indicates that an error has occurred. Additional read operation status bits are also available in the EEPROM Status Register (see Tables 13 and 14).

Upon successful completion of steps 1–4, USER RAM locations 0x200–0x3CF will now contain the data that was stored in the LTM2985's shadow EEPROM.

Table 11. LTM2985 EEPROM Related Registers

ADDRESS	REGISTER NAME	DESCRIPTION
0x0B0	EEPROM Key [3] (MSB)	EEPROM Key byte 3 – Set to 0xA5
0x0B1	EEPROM Key [2]	EEPROM Key byte 2 – Set to 0x3C
0x0B2	EEPROM Key [1]	EEPROM Key byte 1 – Set to 0x0F
0x0B3	EEPROM Key [0] (LSB)	EEPROM Key byte 0 – Set to 0x5A
0x0D0	EEPROM Read Result Code	This register indicates the Pass/Fail status of the most recent EEPROM read operation 0x00 = PASS 0xFF = FAIL
0x0F9	EEPROM Status Register	See LTM2985 EPROM Status Register Tables 12 and 13

Table 12. LTM2985 EEPROM Related Commands and Status

B7	B6	B5	B4	B3	B2	B1	B0	DESCRIPTION
1	0	0	1	0	1	0	1	EEPROM Write Command – Transfer the contents of user memory locations 0x200–0x3CF to the on-chip shadow EEPROM
1	0	0	1	0	1	1	0	EEPROM Read Command – Transfer the contents of the on-chip shadow EEPROM to user memory locations 0x200–0x3CF

Table 13. EEPROM Status Bits

EEPROM STATUS BIT	DESCRIPTION
ECC Used	Error Correcting Code Used – This bit indicates that ECC was used to correct data on one or more locations during the EEPROM read process (Note 20)
ECC Failure	Error Correcting Code Failure – This bit indicates that ECC failed to correct data on one or more locations during the EEPROM read process. If this bit is set one or more locations has invalid data (Note 20)
Program Failure	Program Failure – This bit indicates that a write data error occurred on one or more locations during the EEPROM programming process (Note 20)
Checksum Error	Checksum Error – This bit indicates that a checksum error occurred during the EEPROM read process (Note 20)

Note 20: Once bits in the EEPROM status register are set they will remain set until cleared by the user. The EEPROM status register bits are cleared by writing 0x00 to address 0x0F9. These bits are also cleared after exiting sleep mode.

Table 14. LTM2985 EEPROM Status Register (Address 0x0F9)

7	6	5	4	3	2	1	0
–	–	–	–	Checksum Error	Program Failure	ECC Failure	ECC Used

APPLICATIONS INFORMATION

THERMOCOUPLE MEASUREMENTS

Channel Assignment – Thermocouples

For each thermocouple tied to the LTM2985, a 32-bit channel assignment word is programmed into a memory location corresponding to the channel the sensor is tied to (see Table 15). This word includes (1) thermocouple type, (2) cold junction channel pointer, (3) sensor configuration and (4) custom thermocouple data pointer.

(1) Thermocouple Type

The thermocouple type is determined by the first five input bits B31 to B27 as shown in Table 16. Standard NIST coefficients for types J, K, E, N, R, S, T and B thermocouples are stored in the device ROM. If custom thermocouples are used, the custom thermocouple sensor type can be selected. In this case, user-specific data can be stored in the on-chip RAM starting at the address defined in the custom thermocouple data pointer.

(2) Cold Junction Channel Pointer

The cold junction compensation can be a diode, active analog temperature sensor, RTD, or thermistor. The cold junction channel pointer tells the LTM2985 which channel (1 to 10) the cold junction sensor is assigned to (see Table 17). When a conversion is performed on a channel tied to a thermocouple, the cold junction sensor is simultaneously and automatically measured. The final output data uses the embedded coefficients stored in ROM to automatically compensate the cold junction temperature and output the thermocouple sensor temperature.

(3) Sensor Configuration

The sensor configuration field (see Table 18) is used to select single-ended (B21=1) or differential (B21=0) input and allows selection of open circuit current if internal open-circuit detect is enabled (bit B20). Single-ended readings are measured relative to the COM pin and differential are measured between the selected CH_{TC} and adjacent CH_{TC-1} (see Figure 7). If open-circuit detection is enabled, B20=1, then the user can select the pulsed current value applied during open-circuit detect using bits B18 and B19. The user determines the value of the open circuit current based on the size of the external protection resistor and filter capacitor (typically 10µA). This network needs to settle within 50ms to 1µV or less. The duration of the current pulse is approximately 8ms and occurs 50ms before the normal conversion cycle.

Thermocouple channel assignments follow the general convention shown in Figure 7. The thermocouple positive terminal ties to CH_{TC} (where TC is the selected channel number) for both the single-ended and differential modes of operation. For single-ended measurements the thermocouple negative terminal and the COM pin are grounded. The thermocouple negative terminal is tied to CH_{TC-1} for differential measurements. This node can either be grounded or tied to a bias voltage.

Table 15. Thermocouple Channel Assignment Word

	(1) THERMOCOUPLE TYPE					(2) COLD JUNCTION CHANNEL POINTER					(3) SENSOR CONFIGURATION						(4) CUSTOM THERMOCOUPLE DATA POINTER															
	TABLES 4, 16					TABLE 17					TABLE 18						TABLES 86 TO 88															
Measurement Type	31	30	29	28	27	26	25	24	23	22	21	20	19	18	17	16	15	14	13	12	11	10	9	8	7	6	5	4	3	2	1	0
Thermocouple	Types 1 to 9					Cold Junction Channel Assignment [4:0]					SGL=1	OC	OC		0	0	0	0	0	0	Custom Address [5:0]					Custom Length –1 [5:0]						

APPLICATIONS INFORMATION

Table 16. Thermocouple Type

(1) THERMOCOUPLE TYPE					THERMOCOUPLE TYPES
B31	B30	B29	B28	B27	
0	0	0	0	1	Type J Thermocouple
0	0	0	1	0	Type K Thermocouple
0	0	0	1	1	Type E Thermocouple
0	0	1	0	0	Type N Thermocouple
0	0	1	1	0	Type R Thermocouple
0	0	1	1	1	Type S Thermocouple
0	0	1	1	1	Type T Thermocouple
0	1	0	0	0	Type B Thermocouple
0	1	0	0	1	Custom Thermocouple

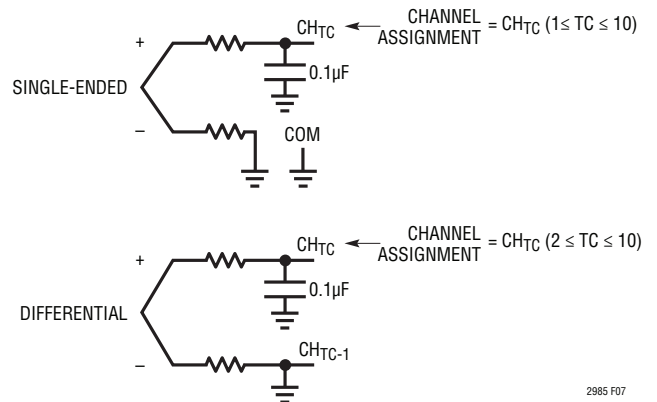

Figure 7. Thermocouple Channel Assignment Convention

Table 17. Cold Junction Channel Pointer

(2) COLD JUNCTION CHANNEL POINTER					COLD JUNCTION CHANNEL
B26	B25	B24	B23	B22	
0	0	0	0	0	No Cold Junction Compensation, 0°C Used for Calculations
0	0	0	0	1	CH1
0	0	0	1	0	CH2
0	0	0	1	1	CH3
0	0	1	0	0	CH4
0	0	1	0	1	CH5
0	0	1	1	0	CH6
0	0	1	1	1	CH7
0	1	0	0	0	CH8
0	1	0	0	1	CH9
0	1	0	1	0	CH10
All Other Combinations					Invalid

Table 18. Sensor Configuration

(3) SENSOR CONFIGURATION				SINGLE-ENDED/ DIFFERENTIAL	OPEN-CIRCUIT CURRENT
SGL	OC CHECK	OC CURRENT			
B21	B20	B19	B18		
0	0	X	X	Differential	External
0	1	0	0	Differential	10µA
0	1	0	1	Differential	100µA
0	1	1	0	Differential	500µA
0	1	1	1	Differential	1mA
1	0	X	X	Single-Ended	External
1	1	0	0	Single-Ended	10µA
1	1	0	1	Single-Ended	100µA
1	1	1	0	Single-Ended	500µA
1	1	1	1	Single-Ended	1mA

APPLICATIONS INFORMATION

(4) Custom Thermocouple Data Pointer

See Custom Thermocouples section near the end of this data sheet for more information.

Fault Reporting – Thermocouple

Each sensor type has a unique fault reporting mechanism indicated in the upper byte of the data output word. Table 19 shows faults reported in the measurement of thermocouples.

Bit D31 indicates the thermocouple sensor is open (broken or not plugged in), the cold junction sensor has a hard fault, or the ADC is out of range. This is indicated by a reading well beyond the normal operating range. Bit D30 indicates a bad ADC reading. This can be a result of either a broken (open) sensor or an excessive noise event (ESD or static discharge into the sensor path). Either of these

are a hard error and -999°C or $^{\circ}\text{F}$ is reported. In the case of an excessive noise event, the device should recover and the following conversions will be valid if the noise event was a random, infrequent event. Bit D29 indicates a hard fault occurred at the cold junction sensor and -999°C or $^{\circ}\text{F}$ is reported. Refer to the specific sensor (diode, thermistor, or RTD) used for cold junction compensation. Bit D28 indicates a soft fault occurred at the cold junction sensor. A valid temperature is reported, but the accuracy may be compromised since the cold junction sensor is operating outside its normal temperature range. Bits D27 and D26 indicate over or under temperature limits have been exceeded for specific thermocouple types, as defined in Table 20. Bit D25 indicates the absolute voltage measured by the ADC is beyond its normal operating range. This fault reflects a reading that is well beyond the normal range of a thermocouple.

Table 19. Thermocouple Fault Reporting

BIT	FAULT	ERROR TYPE	DESCRIPTION	OUTPUT RESULT
D31	Sensor Hard Fault	Hard	Open Circuit or Hard ADC or Hard CJ	-999°C or $^{\circ}\text{F}$
D30	Hard ADC-Out-of-Range	Hard	Bad ADC Reading (Could Be Large External Noise Event)	-999°C or $^{\circ}\text{F}$
D29	CJ Hard Fault	Hard	Cold Junction Sensor Has a Hard Fault Error	-999°C or $^{\circ}\text{F}$
D28	CJ Soft Fault	Soft	Cold Junction Sensor Result Is Beyond Normal Range	Suspect Reading
D27	Sensor Over Range	Soft	Thermocouple Reading Greater Than High Limit	Suspect Reading
D26	Sensor Under Range	Soft	Thermocouple Reading Less Than Low Limit	Suspect Reading
D25	ADC Out-of-Range	Soft	ADC Absolute Input Voltage Is Beyond $\pm 1.125 \cdot V_{\text{REF}}/2$	Suspect Reading
D24	Valid	NA	Result Valid (Should Be 1) Discard Results if 0	Valid Reading

Table 20. Thermocouple Temperature Limits

THERMOCOUPLE TYPE	LOW TEMP LIMIT $^{\circ}\text{C}$	HIGH TEMP LIMIT $^{\circ}\text{C}$
J-Type	-210	1200
K-Type	-265	1372
E-Type	-265	1000
N-Type	-265	1300
R-type	-50	1768
S-Type	-50	1768
T-Type	-265	400
B-Type	40	1820
Custom	Lowest Table Entry	Highest Table Entry

APPLICATIONS INFORMATION

DIODE MEASUREMENTS

Channel Assignment – Diode

For each diode tied to the LTM2985, a 32-bit channel assignment word is programmed into a memory location corresponding to the channel the sensor is tied to (see Table 21). This word includes (1) diode sensor selection, (2) sensor configuration, (3) excitation current and (4) diode ideality factor.

1) Sensor Type

The diode is selected by the first five input bits B31 to B27 (see Table 22).

(2) Sensor Configuration

The sensor configuration field (bits B26 to B24) is used to define various diode measurement properties. Configuration bit B26 is set high for single-ended (measurement relative to COM) and low for differential.

Bit B25 sets the measurement algorithm. If B25 is low, two conversion cycles (one at **1I** and one at **8I** current excitation) are used to measure the diode. This is used in applications where parasitic resistance between the LTM2985 and the diode is small. Parasitic resistance

effects can be removed by setting bit B25 high, enabling three conversion cycles (one at **1I**, one at **4I** and one at **8I**).

Bit B24 enables a running average of the diode temperature reading. This reduces the noise when the diode is used as a cold junction temperature element on an isothermal block where temperatures change slowly.

The algorithm used for diode averaging is a simple recursive running average. The new value is equal to the average of the current reading plus the previous value.

$$\text{NEW VALUE} = \frac{\text{CURRENT READING}}{2} + \frac{\text{PREVIOUS VALUE}}{2}$$

If the current reading is 2°C above or below the previous value, the new value is reset to the current reading.

(3) Excitation Current

The next field in the channel assignment word (B23 to B22) controls the magnitude of the excitation current applied to the diode (see Table 23). In the two conversion cycle mode, the device performs the first conversion at a current equal to 8x the excitation current **1I**. The second conversion occurs at **1I**. Alternatively, in the three conversion cycle mode the first conversion excitation current is **8I**, the second is **4I** and the 3rd is **1I**.

Table 21. Diode Channel Assignment Word

	(1) SENSOR TYPE					(2) SENSOR CONFIGURATION			(3) EXCITATION CURRENT		(4) DIODE IDEALITY FACTOR VALUE																					
	TABLE 22								TABLE 23		TABLE 24																					
Measurement Class	31	30	29	28	27	26	25	24	23	22	21	20	19	18	17	16	15	14	13	12	11	10	9	8	7	6	5	4	3	2	1	0
Diode	Type = 28					SGL=1 DIFF=0	2 or 3 Readings	Avg on	Current [1:0]		Non-Ideality Factor (2, 20) Value from 0 to 4 with 1/1048576 Resolution All Zeros Uses a Factory Set Default of 1.003																					

Table 22. Diode Sensor Selection

(1) SENSOR TYPE					SENSOR TYPE
B31	B30	B29	B28	B27	
1	1	1	0	0	Diode

Table 23. Diode Excitation Current Selection

(3) EXCITATION CURRENT		1I	4I	8I
B23	B22			
0	0	10µA	40µA	80µA
0	1	20µA	80µA	160µA
1	0	40µA	160µA	320µA
1	1	80µA	320µA	640µA

APPLICATIONS INFORMATION

(4) Diode Ideality Factor

The last field in the channel assignment word (B21 to B0) sets the diode ideality factor within the range 0 to 4 with $1/1048576$ (2^{-20}) resolution. The top two bits (B21 to B20) are the integer part and bits B19 to B0 are the fractional part of the ideality factor (see Table 24).

Diode channel assignments follow the general convention shown in Figure 8. The anode ties to CH_D (where D is the selected channel number) for both the single-ended and differential modes of operation and the cathode is grounded. For differential diode measurements, the cathode is also tied to CH_{D-1} .

Fault Reporting – Diode

Each sensor type has unique fault reporting mechanism indicated in the upper byte of the data output word. Table 25 shows faults reported in the measurement of diodes.

Bit D31 indicates the diode is open, shorted, not plugged in, wired backwards, or the ADC reading is bad. Any of these are hard faults and -999°C or $^{\circ}\text{F}$ is reported. Bit D30 indicates a bad ADC reading. This can be a result of either a broken (open) sensor or an excessive noise event (ESD or static discharge into the sensor path). This is a hard error and -999°C or $^{\circ}\text{F}$ is reported. In the case of

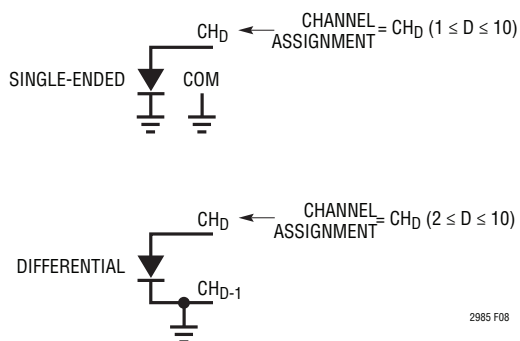

Figure 8. Diode Channel Assignment Convention

Table 24. Programming Diode Ideality Factor

	(4) DIODE IDEALITY FACTOR VALUE																					
	B21	B20	B19	B18	B17	B16	B15	B14	B13	B12	B11	B10	B9	B8	B7	B6	B5	B4	B3	B2	B1	B0
Example h	2^1	2^0	2^{-1}	2^{-2}	2^{-3}	2^{-4}	2^{-5}	2^{-6}	2^{-7}	2^{-8}	2^{-9}	2^{-10}	2^{-11}	2^{-12}	2^{-13}	2^{-14}	2^{-15}	2^{-16}	2^{-17}	2^{-18}	2^{-19}	2^{-20}
1.25	0	1	0	1	0	0	0	0	0	0	0	0	0	0	0	0	0	0	0	0	0	0
1.003 (Default)	0	0	0	0	0	0	0	0	0	0	0	0	0	0	0	0	0	0	0	0	0	0
1.006	0	1	0	0	0	0	0	0	0	1	1	0	0	0	1	0	0	1	0	0	1	1

Table 25. Diode Fault Reporting

BIT	FAULT	ERROR TYPE	DESCRIPTION	OUTPUT RESULT
D31	Sensor Hard Fault	Hard	Open, Short, Reversed, or Hard ADC	-999°C or $^{\circ}\text{F}$
D30	Hard ADC-Out-of-Range	Hard	Bad ADC Reading (Could Be Large External Noise Event)	-999°C or $^{\circ}\text{F}$
D29	Not Used for Diodes	N/A	Always 0	
D28	Not Used for Diodes	N/A	Always 0	
D27	Sensor Over Range	Soft	$T > 130^{\circ}\text{C}$	Suspect Reading
D26	Sensor Under Range	Soft	$T < -60^{\circ}\text{C}$	Suspect Reading
D25	ADC Out-of-Range	Soft	ADC Absolute Input Voltage Is Beyond $\pm 1.125 \cdot V_{\text{REF}}/2$	Suspect Reading
D24	Valid	NA	Result Valid (Should Be 1) Discard Results if 0	Valid Reading

APPLICATIONS INFORMATION

an excessive noise event, the device should recover and the following conversions will be valid if the noise event was a random, infrequent event. Bits D29 and D28 are not used for diodes. Bits D27 and D26 indicate over or under temperature limits (defined as $T > 130^{\circ}\text{C}$ or $T < -60^{\circ}\text{C}$). The calculated temperature is reported, but the accuracy may be compromised. Bit D25 indicates the absolute voltage measured by the ADC is beyond its normal operating range. If a diode is used as the cold junction element, any hard or soft error is flagged in the corresponding thermocouple result (bits D28 and D29 in Table 19).

Example: Single-Ended Type K and Differential Type T Thermocouples with Shared Diode Cold Junction Compensation

Figure 9 shows a typical temperature measurement system where two thermocouples share a single cold junction diode. In this example, a Type K thermocouple is tied to CH1 and a Type T thermocouple is tied to CH3 and CH4. They both share a single cold junction diode with ideality factor of $\eta = 1.003$ tied to CH2. Channel assignment data for both thermocouples and the diode are shown in

Tables 26 to 28. Thermocouple #1 (Type K) sensor type and configuration data are assigned to CH1. 32-bits of binary configuration data are mapped directly into memory locations 0x200 to 0x203 (see Table 26). The cold junction diode sensor type and configuration data are assigned to CH2. 32-bits of binary configuration data are mapped directly into memory locations 0x204 to 0x207 (see Table 27). Thermocouple #2 (Type T) sensor type and configuration data are assigned to CH4. 32-bits of binary configuration data are mapped directly into memory locations 0x20C to 0x20F (see Table 28). A conversion is initiated on CH1 by writing 10000001 into memory location 0x000. Both the Type K thermocouple and the diode are measured simultaneously. The LTM2985 calculates the cold junction compensation and determines the temperature of the Type K thermocouple. Once the conversion is complete, the INT pin goes HIGH and memory location 0x000 becomes 01000001. Similarly, a conversion can be initiated on CH4 by writing 10000100 into memory location 0x000. The results (in $^{\circ}\text{C}$) can be read from memory locations 0x010 to 0x013 for CH1 and 0x01C to 0x01F for CH4.

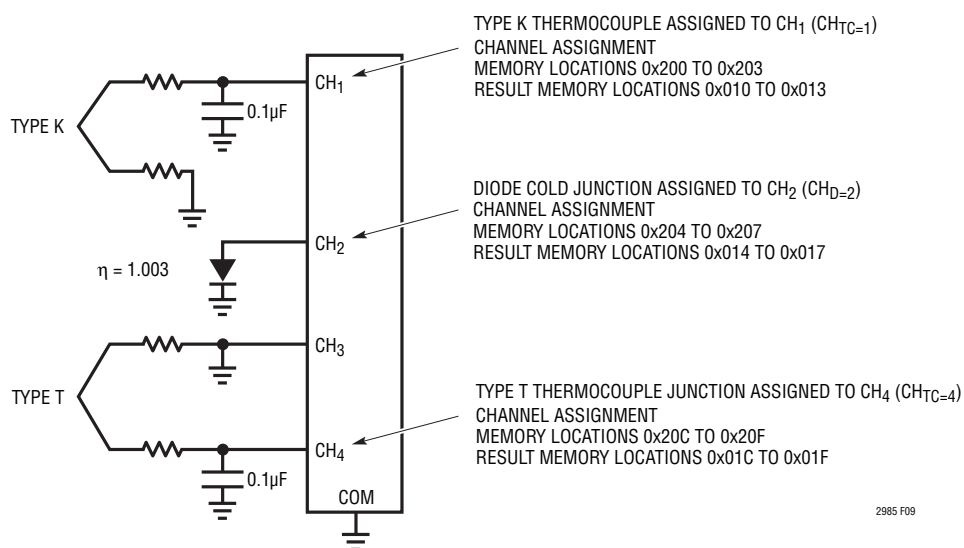

Figure 9. Dual Thermocouple with Diode Cold Junction Example

APPLICATIONS INFORMATION

Table 26. Thermocouple #1 Channel Assignment (Type K, Cold Junction CH₂, Single-Ended, 10μA Open-Circuit Detect)

CONFIGURATION FIELD	DESCRIPTION	# BITS	BINARY DATA	MEMORY ADDRESS 0x200	MEMORY ADDRESS 0x201	MEMORY ADDRESS 0x202	MEMORY ADDRESS 0x203
(1) Thermocouple Type	Type K	5	00010	0 0 0 1 0			
(2) Cold Junction Channel Pointer	CH ₂	5	00010		0 0 0 1 0		
(3) Sensor Configuration	Single-Ended, 10μA Open-Circuit	4	1100		1 1 0 0		
Not Used	Set These Bits to 0	6	000000			0 0 0 0 0 0	
(4) Custom Thermocouple Data Pointer	Not Custom	12	000000000000				0 0 0 0 0 0 0 0 0 0 0 0

Table 27. Diode Channel Assignment (Single-Ended 3-Reading, Averaging On, 20μA/80μA Excitation, Ideality Factor = 1.003)

CONFIGURATION FIELD	DESCRIPTION	# BITS	BINARY DATA	MEMORY ADDRESS 0x204	MEMORY ADDRESS 0x205	MEMORY ADDRESS 0x206	MEMORY ADDRESS 0x207
(1) Sensor Type	Diode	5	11100	1 1 1 0 0			
(2) Sensor Configuration	Single-Ended, 3-Reading, Average On	3	111		1 1 1		
(3) Excitation Current	20μA, 80μA, 160μA	2	01		0 1		
(4) Ideality Factor	1.003	22	010000000110001001001			0 1 0 0 0 0 0 0 0 0 1 1 0 0 0 1 0 0 1 0 0 1	

Table 28. Thermocouple #2 Channel Assignment (Type T, Cold Junction CH₂, Differential, 100μA Open-Circuit Detect)

CONFIGURATION FIELD	DESCRIPTION	# BITS	BINARY DATA	MEMORY ADDRESS 0x20C	MEMORY ADDRESS 0x20D	MEMORY ADDRESS 0x20E	MEMORY ADDRESS 0x20F
(1) Thermocouple Type	Type T	5	00111	0 0 1 1 1			
(2) Cold Junction Channel Pointer	CH ₂	5	00010		0 0 0 1 0		
(3) Sensor Configuration	Differential, 100μA Open-Circuit Current	4	0101		0 1 0 1		
Not Used	Set These Bits to 0	6	000000			0 0 0 0 0 0	
(4) Custom Thermocouple Data Pointer	Not Custom	12	000000000000				0 0 0 0 0 0 0 0 0 0 0 0

APPLICATIONS INFORMATION

RTD MEASUREMENTS

Channel Assignment – RTD

For each RTD tied to the LTM2985, a 32-bit channel assignment word is programmed into a memory location corresponding to the channel the sensor is tied to (see Table 29). This word includes (1) RTD type, (2) sense resistor channel pointer, (3) sensor configuration, (4) excitation current, (5) RTD curve and (6) custom RTD data pointer.

(1) RTD Type

The RTD type is determined by the first five input bits B31 to B27 as shown in Table 30. Linearization coefficients for RTD types PT-10, PT-50, PT-100, PT-200, PT-500, PT-1000 and NI-120 with selectable common curves ($\alpha = 0.003850$, $\alpha = 0.003911$, $\alpha = 0.003916$ and $\alpha = 0.003926$) are built into the device. If custom RTDs are used, RTD Custom can be selected. In this case, user specific data can be stored in the on-chip RAM starting at the address defined by the custom RTD data pointers.

(2) Sense Resistor Channel Pointer

RTD measurements are performed ratiometrically relative to a known R_{SENSE} resistor. The sense resistor channel pointer field indicates the differential channel the sense resistor is tied to for the RTD (see Table 31). Sense resistors are always measured differentially.

(3) Sensor Configuration

The sensor configuration field is used to define various RTD properties. Configuration bits B20 and B21 determine if the RTD is a 2-, 3-, or 4-wire type (see Table 32).

The simplest configuration is the 2-wire configuration. While this setup is simple, parasitic errors due to IR drops in the leads result in systematic temperature errors. The 3-wire configuration cancels RTD lead resistance errors (if the lines are equal resistance) by applying two matched current sources to the RTD, one per lead. Mismatches in the two current sources are removed through transparent background calibration. 4-wire RTDs remove unbalanced RTD lead resistance by measuring directly across the sensor using a high impedance Kelvin sensing. 4-wire measurements with Kelvin R_{SENSE} are useful in applications where sense resistor wiring parasitics can lead to errors; this is especially useful for low resistance PT-10 type RTDs. In this case, both the RTD and sense resistor have Kelvin sensing connections.

The next sensor configuration bits (B18 and B19) determine the excitation current mode. These bits are used to enable R_{SENSE} sharing, where one sense resistor is used for multiple 2-, 3- and/or 4-wire RTDs. In this case, the RTD ground connection is internal and each RTD points to the same R_{SENSE} channel.

Bits B18 and B19 are also used to enable excitation current rotation to automatically remove parasitic thermocouple effects. Parasitic thermocouple effects may arise from the physical connected between the RTD and the measurement instrument. This mode is available for all 4-wire configurations using internal current source excitation.

Table 29. RTD Channel Assignment Word

	(1) RTD TYPE					(2) SENSE RESISTOR CHANNEL POINTER					(3) SENSOR CONFIGURATION				(4) EXCITATION CURRENT				(5) RTD CURVE		(6) CUSTOM RTD DATA POINTER													
	TABLE 30					TABLE 31					TABLE 32				TABLE 33				TABLE 34		TABLES 92 TO 94													
Measurement Class	31	30	29	28	27	26	25	24	23	22	21	20	19	18	17	16	15	14	13	12	11	10	9	8	7	6	5	4	3	2	1	0		
RTD	Type = 10 to 18					R_{SENSE} Channel Assignment [4:0]					2, 3, 4 Wire				Excitation Mode				Excitation Current [3:0]				Curve [1:0]		Custom Address [5:0]					Custom Length-1 [5:0]				

APPLICATIONS INFORMATION

Table 30. RTD Type

(1) RTD TYPE					RTD TYPE
B31	B30	B29	B28	B27	
0	1	0	1	0	RTD PT-10
0	1	0	1	1	RTD PT-50
0	1	1	0	0	RTD PT-100
0	1	1	0	1	RTD PT-200
0	1	1	1	0	RTD PT-500
0	1	1	1	1	RTD PT-1000
1	0	0	0	0	RTD 1000 ($\alpha = 0.00375$)
1	0	0	0	1	RTD NI-120
1	0	0	1	0	RTD Custom

Table 31. Sense Resistor Channel Pointer

(2) SENSE RESISTOR CHANNEL POINTER					SENSE RESISTOR CHANNEL
B26	B25	B24	B23	B22	
0	0	0	0	0	Invalid
0	0	0	0	1	Invalid
0	0	0	1	0	CH2-CH1
0	0	0	1	1	CH3-CH2
0	0	1	0	0	CH4-CH3
0	0	1	0	1	CH5-CH4
0	0	1	1	0	CH6-CH5
0	0	1	1	1	CH7-CH6
0	1	0	0	0	CH8-CH7
0	1	0	0	1	CH9-CH8
0	1	0	1	0	CH10-CH9
All Other Combinations					Invalid

APPLICATIONS INFORMATION

Table 32. RTD Sensor Configuration Selection

(3) SENSE CONFIGURATION				MEASUREMENT MODE					BENEFITS			
NUMBER OF WIRES		EXCITATION MODE		NUMBER OF WIRES	GROUND CONNECTION	CURRENT SOURCE ROTATION	SENSE RESISTOR SHARING	RTDs POSSIBLE PER DEVICE	CANCELS RTD MATCHED LEAD RESISTANCE	CANCELS RTD MISMATCH LEAD RESISTANCE	CANCELS PARASITIC THERMOCOUPLE EFFECTS	CANCELS R _{SENSE} LEAD RESISTANCE
B21	B20	B19	B18									
0	0	0	0	2-Wire	External	No	No	2				
0	0	0	1	2-Wire	Internal	No	Yes	4				
0	1	0	0	3-Wire	External	No	No	2	•			
0	1	0	1	3-Wire	Internal	No	Yes	4	•			
0	1	1	X	Reserved								
1	0	0	0	4-Wire	External	No	No	2	•	•		
1	0	0	1	4-Wire	Internal	No	Yes	2	•	•		
1	0	1	0	4-Wire	Internal	Yes	Yes	2	•	•	•	
1	0	1	1	Reserved								
1	1	0	0	4-Wire, Kelvin R _{SENSE}	External	No	No	2	•	•		•
1	1	0	1	4-Wire, Kelvin R _{SENSE}	Internal	No	Yes	2	•	•		•
1	1	1	0	4-Wire, Kelvin R _{SENSE}	Internal	Yes	Yes	2	•	•	•	•
1	1	1	1	Reserved								

APPLICATIONS INFORMATION

(4) Excitation Current

The next field in the channel assignment word (B17 to B14) controls the magnitude of the excitation current applied to the RTD (see Table 33). The current selected is the total current flowing through the RTD independent of the wiring configuration. The R_{SENSE} current is 2x the sensor excitation current for 3-wire RTDs.

Table 33. Total Excitation Current for All RTD Wire Types

(4) EXCITATION CURRENT				
B17	B16	B15	B14	CURRENT
0	0	0	0	External
0	0	0	1	5 μ A
0	0	1	0	10 μ A
0	0	1	1	25 μ A
0	1	0	0	50 μ A
0	1	0	1	100 μ A
0	1	1	0	250 μ A
0	1	1	1	500 μ A
1	0	0	0	1mA

In order to prevent soft or hard faults, select a current such that the maximum voltage drop across the sensor or sense resistor is nominally 1.0V. For example, if R_{SENSE} is 10k Ω and the RTD is a PT-100, select an excitation current of 100 μ A for 2-wire and 4-wire RTDs and select 50 μ A for a 3-wire RTD. Alternatively, using a 1k Ω sense resistor with a PT-100 RTD allows 500 μ A excitation for any wiring configuration.

(5) RTD Curve

Bits B13 and B12 set the RTD curve used and the corresponding Callendar-Van Dusen constants (shown in Table 34).

(6) Custom RTD Data Pointer

In the case where an RTD not listed in Table 34 is used, a custom RTD table may be entered into the LTM2985.

See Custom RTD section near the end of this data sheet for more information.

Table 34. RTD Curves: $RT = R_0 \cdot (1 + a \cdot T + b \cdot T^2 + (T - 100^\circ\text{C}) \cdot c \cdot T^3)$ for $T < 0^\circ\text{C}$, $RT = R_0 \cdot (1 + a \cdot T + b \cdot T^2)$ for $T > 0^\circ\text{C}$

(5) CURVE		CURVE	ALPHA	a	b	c
B13	B12					
0	0	European Curve	0.00385	3.908300E-03	-5.775000E-07	-4.183000E-12
0	1	American	0.003911	3.969200E-03	-5.849500E-07	-4.232500E-12
1	0	Japanese	0.003916	3.973900E-03	-5.870000E-07	-4.400000E-12
1	1	ITS-90	0.003926	3.984800E-03	-5.870000E-07	-4.000000E-12
X	X	RTD1000-375	0.00375	3.810200E-03	-6.018880E-07	-6.000000E-12
X	X	*NI-120	N/A	N/A	N/A	N/A

*NI-120 uses table based data.

APPLICATIONS INFORMATION

Fault Reporting – RTD

Each sensor type has unique fault reporting mechanism indicated in the most significant byte of the data output word. Table 35 shows faults reported in the measurement of RTDs.

Bit D31 indicates the RTD or R_{SENSE} is open, shorted, or not plugged in. This is a hard fault and -999°C or $^{\circ}\text{F}$ is reported. Bit D30 indicates a bad ADC reading. This can be a result of either a broken (open) sensor or an excessive noise event (ESD or static discharge into the sensor path). This is a hard error and -999°C or $^{\circ}\text{F}$ is reported. In the case of an excessive noise event, the device should recover and the following conversions will be valid if the noise was a random infrequent event. Bits D29 and D28 are not used

for RTDs. Bits D27 and D26 indicate over or under temperature limits (see Table 36). The calculated temperature is reported, but the accuracy may be compromised. Bit D25 indicates the absolute voltage measured by the ADC is beyond its normal operating range. If an RTD is used as the cold junction element, any hard or soft error is also flagged in the thermocouple result.

Sense Resistor Channel Assignment

For each sense resistor tied to the LTM2985, a 32-bit channel assignment word is programmed into a memory location corresponding to the channel the sensor is tied to (see Table 37). This word includes (1) sense resistor selection and (2) sense resistor value.

Table 35. RTD Fault Reporting

BIT	FAULT	ERROR TYPE	DESCRIPTION	OUTPUT RESULT
D31	Sensor Hard Fault	Hard	Open or Short RTD or R_{SENSE}	-999°C or $^{\circ}\text{F}$
D30	Hard ADC-Out-of-Range	Hard	Bad ADC Reading (Could Be Large External Noise Event)	-999°C or $^{\circ}\text{F}$
D29	Not Used for RTDs	N/A	Always 0	Valid Reading
D28	Not Used for RTDs	N/A	Always 0	Valid Reading
D27	Sensor Over Range	Soft	$T >$ High Temp Limit (See Table 36)	Suspect Reading
D26	Sensor Under Range	Soft	$T <$ Low Temp Limit (See Table 36)	Suspect Reading
D25	ADC Out-of-Range	Soft	ADC Absolute Input Voltage Is Beyond $\pm 1.125 \cdot V_{REF}/2$	Suspect Reading
D24	Valid	N/A	Result Valid (Should Be 1) Discard Results if 0	Valid Reading

Table 36. Table 36. Voltage and Resistance Ranges

RTD TYPE	MIN Ω	MAX Ω	LOW TEMP LIMIT $^{\circ}\text{C}$	HIGH TEMP LIMIT $^{\circ}\text{C}$
PT-10	1.95	34.5	-200	850
PT-50	9.75	172.5	-200	850
PT-100	19.5	345	-200	850
PT-200	39	690	-200	850
PT-500	97.5	1725	-200	850
PT-1000	195	3450	-200	850
NI-120	66.6	380.3	-80	260
Custom Table	Lowest Table Entry	Highest Table Entry	Lowest Table Entry	Highest Table Entry

Table 37. Sense Resistor Channel Assignment Word

	(1) SENSOR TYPE					(2) SENSE RESISTOR VALUE (Ω)																										
	Table 38					Table 39																										
Measurement Class	31	30	29	28	27	26	25	24	23	22	21	20	19	18	17	16	15	14	13	12	11	10	9	8	7	6	5	4	3	2	1	0
Sense Resistor	Type = 29					Sense Resistor Value (17, 10) Up to $\approx 131,072\Omega$ with $1/1024\Omega$ Resolution																										

APPLICATIONS INFORMATION

(1) Sensor Type

The sense resistor is selected by setting the first 5 input bits, B31 to B27, to 11101 (see Table 38).

Table 38. Sense Resistor Selection

(1) SENSOR TYPE					SENSOR TYPE
B31	B30	B29	B28	B27	
1	1	1	0	1	Sense Resistor

(2) Sense Resistor Value

The last field in the channel assignment word (B26 to B0) sets the value of the sense resistor within the range 0 to 131,072Ω with 1/1024Ω precision (see Table 39). The top 17 bits (B26 to B10) create the integer and bits B9 to B0 create the fraction of the sense resistor value.

Example: 2-Wire RTD

The simplest RTD configuration is the 2-wire configuration, 2-wire RTDs follow the general convention shown in Figure 10. They require only two connections per RTD and can be tied directly to 2-lead RTD elements. This topology, however, causes errors due to parasitic lead resistance. If sharing is not selected (1 R_{SENSE} per RTD), then CH_{RTD} should be grounded. The ground connection should be removed if sharing is enabled (1 R_{SENSE} for multiple RTDs).

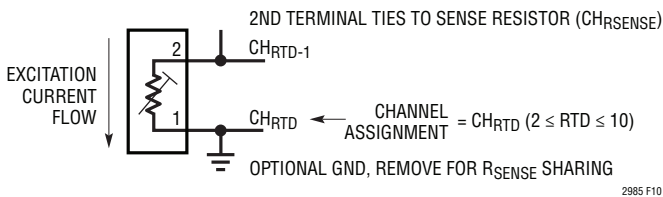

Figure 10. 2-Wire RTD Channel Assignment Convention

Table 39. Example Sense Resistor Values

	(2) SENSE RESISTOR VALUE (Ω)																															
	B26	B25	B24	B23	B22	B21	B20	B19	B18	B17	B16	B15	B14	B13	B12	B11	B10	B9	B8	B7	B6	B5	B4	B3	B2	B1	B0					
Example R	2 ¹⁶	2 ¹⁵	2 ¹⁴	2 ¹³	2 ¹²	2 ¹¹	2 ¹⁰	2 ⁹	2 ⁸	2 ⁷	2 ⁶	2 ⁵	2 ⁴	2 ³	2 ²	2 ¹	2 ⁰	2 ⁻¹	2 ⁻²	2 ⁻³	2 ⁻⁴	2 ⁻⁵	2 ⁻⁶	2 ⁻⁷	2 ⁻⁸	2 ⁻⁹	2 ⁻¹⁰					
10,000.2Ω	0	0	0	1	0	0	1	1	1	0	0	0	1	0	0	0	0	0	0	1	1	0	0	1	1	0	1					
99.99521kΩ	1	1	0	0	0	0	1	1	0	1	0	0	1	1	0	1	1	0	0	1	1	0	1	0	1	1	1					
1.0023kΩ	0	0	0	0	0	0	0	1	1	1	1	1	0	1	0	1	0	0	1	0	0	1	1	0	0	1	1					

Sense resistor channel assignments follow the general convention shown in Figure 11. The sense resistor is tied between CH_{SENSE} and CH_{SENSE-1}, where CH_{SENSE} is tied to the 2nd terminal of the RTD. Channel assignment data (see Table 37) is mapped into a memory location corresponding to CH_{SENSE}.

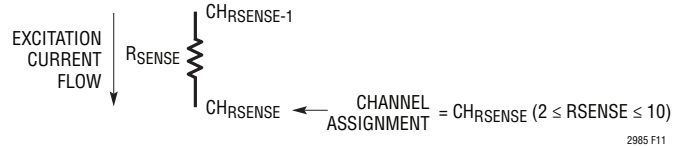

Figure 11. Sense Resistor Channel Assignment Convention for 2-Wire RTDs

Example: 2-Wire RTDs with Shared R_{SENSE}

Figure 12 shows a typical temperature measurement system using multiple 2-wire RTDs. In this example, a PT-1000 RTD ties to CH7 and CH8 and an NI-120 RTD ties to CH9 and CH10. Using this configuration, the LTM2985 can digitize up to four 2-wire RTDs with a single sense resistor.

RTD #1 sensor type and configuration data are assigned to CH8. 32 bits of binary configuration data are mapped directly into memory locations 0x21C to 0x21F (see Table 40). RTD #2 sensor type and configuration data are assigned to CH10. 32-bits of binary configuration data are mapped directly into memory locations 0x224 to 0x227 (see Table 41). The sense resistor is assigned to CH6. The user-programmable value of this resistor is 5001.5Ω. 32 bits of binary configuration data are mapped directly into memory locations 0x214 to 0x217 (see Table 42).

A conversion is initiated on CH8 by writing 10001000 into memory location 0x000. Once the conversion is complete, the INT pin goes HIGH and memory location 0x000 becomes 01001000. The resulting temperature in °C can be read from memory locations 0x02C to 0x02F (corresponding to CH8). A conversion can be initiated and read from CH10 in a similar fashion.

APPLICATIONS INFORMATION

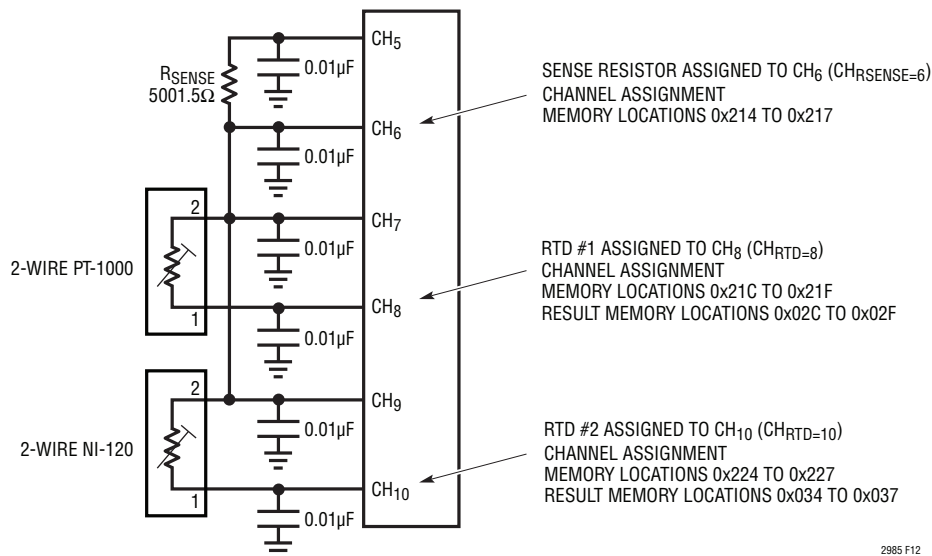

2985 F12

Figure 12. Shared 2-Wire RTD Example

Table 40. Channel Assignment Data for 2-Wire RTD #1 (PT-1000, R_{SENSE} on CH₆, 2-Wire, Shared R_{SENSE}, 10µA Excitation Current, $\alpha = 0.003916$ Curve)

CONFIGURATION FIELD	DESCRIPTION	# BITS	BINARY DATA	MEMORY ADDRESS 0x21C	MEMORY ADDRESS 0x21D	MEMORY ADDRESS 0x21E	MEMORY ADDRESS 0x21F
(1) RTD TYPE	PT-1000	5	01111	0 1 1 1 1			
(2) Sense Resistor Channel Pointer	CH ₆	5	00110		0 0 1 1 0		
(3) Sensor Configuration	2-Wire with Shared R _{SENSE}	4	0001			0 0 0 1	
(4) Excitation Current	10µA	4	0010			0 0 1 0	
(5) Curve	Japanese, $\alpha = 0.003916$	2	10				1 0
(6) Custom RTD Data Pointer	Not Custom	12	000000000000				0 0 0 0 0 0 0 0 0 0 0 0

APPLICATIONS INFORMATION

Table 41. Channel Assignment Data for 2-Wire RTD #2 (NI-120, R_{SENSE} on CH₆, 2-Wire, Shared R_{SENSE}, 100µA Excitation Current)

CONFIGURATION FIELD	DESCRIPTION	# BITS	BINARY DATA	MEMORY ADDRESS 0x224	MEMORY ADDRESS 0x225	MEMORY ADDRESS 0x226	MEMORY ADDRESS 0x227
(1) RTD TYPE	NI-120	5	10001	1 0 0 0 1			
(2) Sense Resistor Channel Pointer	CH ₆	5	00110		0 0 1 1 0		
(3) Sensor Configuration	2-Wire with Shared R _{SENSE}	4	0001		0 0 0 1		
(4) Excitation Current	100µA	4	0101			0 1 0 1	
(5) Curve	European α = 0.00385	2	00			0 0	
(6) Custom RTD Data Pointer	Not Custom	12	000000000000				0 0 0 0 0 0 0 0 0 0 0 0

Table 42. Channel Assignment Data for Sense Resistor (Value = 5001.5Ω)

CONFIGURATION FIELD	DESCRIPTION	# BITS	BINARY DATA	MEMORY ADDRESS 0x214	MEMORY ADDRESS 0x215	MEMORY ADDRESS 0x216	MEMORY ADDRESS 0x217
(1) Sensor Type	Sense Resistor	5	11101	1 1 1 0 1			
(2) Sense Resistor Value	5001.5Ω	27	000010011100010011000000000		0 0 0 0 1 0 0 1 1 1 0	0 0 1 0 0 1 1 0	0 0 0 0 0 0 0 0

APPLICATIONS INFORMATION

Example: 3-Wire RTD

3-wire RTD channel assignments follow the general convention shown in Figure 13. Terminals 1 and 2 tie to the input/excitation current sources and terminal 3 connects to the sense resistor. Channel assignment data is mapped to memory locations corresponding to CH_{RTD} .

Sense resistor channel assignments follow the general convention shown in Figure 14. The sense resistor is tied between CH_{RSENSE} and $CH_{RSENSE-1}$, where CH_{RSENSE} is tied to the 3rd terminal of the RTD and $CH_{RSENSE-1}$ is tied to ground (or left floating for R_{SENSE} sharing). Channel assignment data (see Table 37) is mapped into the memory location corresponding to CH_{RSENSE} .

Figure 15 shows a typical temperature measurement system using a 3-wire RTD. In this example, a 3-wire RTD's terminals tie to CH9, CH8 and CH7. The sense resistor ties to CH7 and CH6. The sense resistor and RTD connect together at CH7.

The 3-wire RTD reduces the errors associated with parasitic lead resistance by applying excitation current to each RTD input. This first order cancellation removes matched lead resistance errors. This cancellation does not remove errors due to thermocouple effects or mismatched lead resistances. The RTD sensor type and configuration data are assigned to CH9. 32 bits of binary configuration data are mapped directly into memory locations 0x220 to 0x223 (see Table 43). The sense resistor is assigned to CH7. The user-programmable value of this resistor is 12150.39 Ω . 32 bits of binary configuration data are mapped directly into memory locations 0x218 to 0x21B (see Table 44).

A conversion is initiated on CH9 by writing 10001001 into memory location 0x000. Once the conversion is complete, the INT pin goes HIGH and memory location 0x000 becomes 01001001. The resulting temperature in $^{\circ}\text{C}$ can be read from memory locations 0x030 to 0x033 (corresponding to CH9).

APPLICATIONS INFORMATION

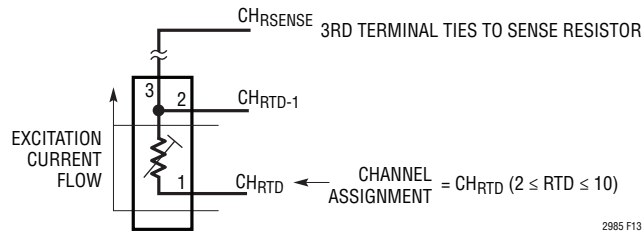

Figure 13. 3-Wire RTD Channel Assignment Convention

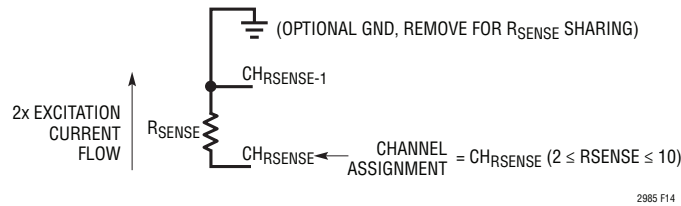

Figure 14. 3-Wire Sense Resistor Channel Assignment Convention for 3-Wire RTDs

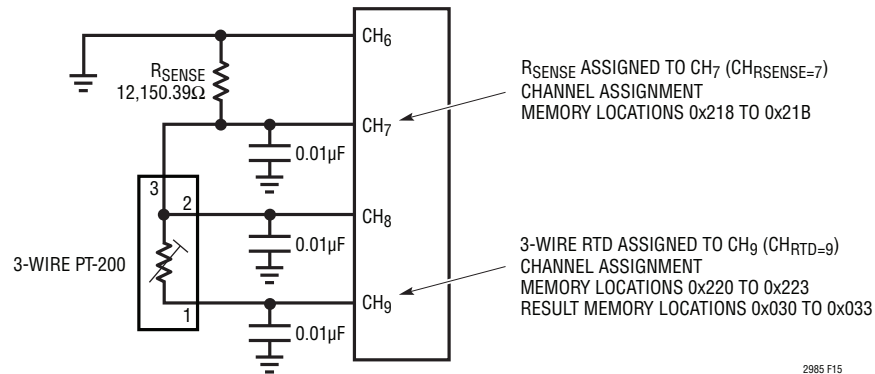

Figure 15. 3-Wire RTD Example

APPLICATIONS INFORMATION

Table 43. Channel Assignment Data for 3-Wire RTD (PT-200, R_{SENSE} on CH₇, 3-Wire, 50 μ A Excitation Current, α = 0.003911 Curve)

CONFIGURATION FIELD	DESCRIPTION	# BITS	BINARY DATA	MEMORY ADDRESS 0x220	MEMORY ADDRESS 0x221	MEMORY ADDRESS 0x222	MEMORY ADDRESS 0x223
(1) RTD TYPE	PT-200	5	01101	0 1 1 0 1			
(2) Sense Resistor Channel Pointer	CH ₇	5	00111		0 0 1 1 1		
(3) Sensor Configuration	3-Wire	4	0100		0 1 0 0		
(4) Excitation Current	50 μ A	4	0100		0 1 0 0		
(5) Curve	American, α = 0.003911	2	01			0 1	
(6) Custom RTD Data Pointer	Not Custom	12	000000000000				0 0 0 0 0 0 0 0 0 0 0 0

Table 44. Channel Assignment Data for Sense Resistor (Value = 12150.39 Ω)

CONFIGURATION FIELD	DESCRIPTION	# BITS	BINARY DATA	MEMORY ADDRESS 0x218	MEMORY ADDRESS 0x219	MEMORY ADDRESS 0x21A	MEMORY ADDRESS 0x21B
(1) Sensor Type	Sense Resistor	5	11101	1 1 1 0 1			
(2) Sense Resistor Value	12150.39 Ω	27	000101111011101100110001111		0 0 0 1 0 1 1 1 1 0 1	1 1 0 1 1 0 0 1 1 0 0 0 1 1 1 0	

APPLICATIONS INFORMATION

Example: Standard 4-Wire RTD (No Rotation or R_{SENSE} Sharing)

Standard 4-wire RTD channel assignments follow the general convention shown in Figure 16. Terminal 1 is tied to ground, terminals 2 and 3 (Kelvin sensed signal) tie to CH_{RTD} and CH_{RTD-1} and the 4th terminal ties to the sense resistor. Channel assignment data (see Table 29) is mapped to memory locations corresponding to CH_{RTD} .

Sense resistor channel assignments follow the general convention shown in Figure 17. The sense resistor is tied between CH_{RSENSE} and $CH_{RSENSE-1}$, where CH_{RSENSE} is tied to the 4th terminal of the RTD. Channel assignment data (see Table 37) is mapped into a memory location corresponding to CH_{RSENSE} .

Figure 18 shows a typical temperature measurement system using a 4-wire RTD. In this example, a 4-wire RTD's

terminals tie to GND, CH4, CH3 and CH2. The sense resistor ties to CH2 and CH1. The sense resistor and RTD share a common connection at CH2. The RTD sensor type and configuration data are assigned to CH4. 32 bits of binary configuration data are mapped directly into memory locations 0x20C to 0x20F (see Table 45). The sense resistor is assigned to CH2. The user-programmable value of this resistor is 5000.2Ω . 32 bits of binary configuration data are mapped directly into memory locations 0x204 to 0x207 (see Table 46).

A conversion is initiated on CH4 by writing 1000100 into the data byte at memory location 0x000. Once the conversion is complete, the INT pin goes HIGH and memory location 0x000 becomes 01000100. The resulting temperature in $^{\circ}C$ can be read from memory locations 0x01C to 0x01F (corresponding to CH4).

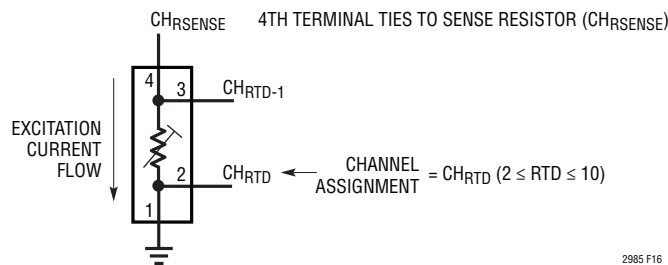

Figure 16. 4-Wire RTD Channel Assignment Convention

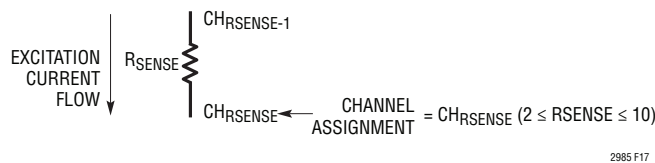

Figure 17. Sense Resistor Channel Assignment Convention for 4-Wire RTDs

APPLICATIONS INFORMATION

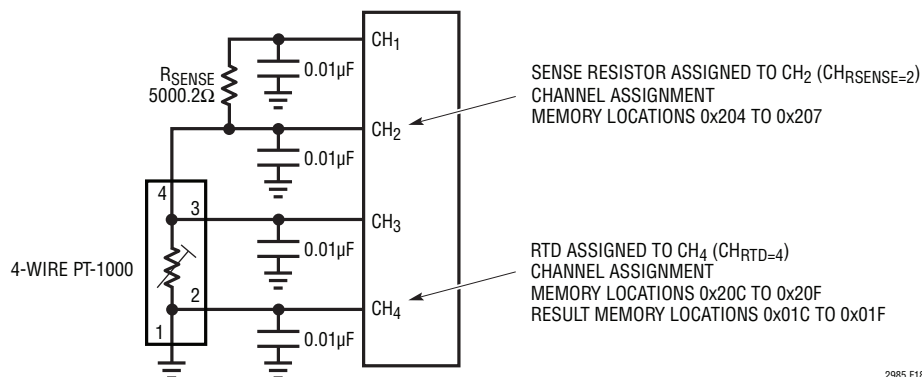

Figure 18. Standard 4-Wire RTD Example

Table 45. Channel Assignment Data for 4-Wire RTD (PT-1000, R_{SENSE} on CH₂, Standard 4-Wire, 25μA Excitation Current, $\alpha = 0.00385$ Curve)

CONFIGURATION FIELD	DESCRIPTION	# BITS	BINARY DATA	MEMORY ADDRESS 0x20C	MEMORY ADDRESS 0x20D	MEMORY ADDRESS 0x20E	MEMORY ADDRESS 0x20F
(1) RTD TYPE	PT-1000	5	01111	0 1 1 1 1			
(2) Sense Resistor Channel Pointer	CH ₂	5	00010		0 0 0 1 0		
(3) Sensor Configuration	4-Wire, No Rotate, No Share	4	1000		1 0 0 0		
(4) Excitation Current	25μA	4	0011			0 0 1 1	
(5) Curve	European, $\alpha = 0.00385$	2	00			0 0	
(6) Custom RTD Data Pointer	Not Custom	12	000000000000				0 0 0 0 0 0 0 0 0 0 0 0

Table 46. Channel Assignment Data for Sense Resistor (Value = 5000.2Ω)

CONFIGURATION FIELD	DESCRIPTION	# BITS	BINARY DATA	MEMORY ADDRESS 0x204	MEMORY ADDRESS 0x205	MEMORY ADDRESS 0x206	MEMORY ADDRESS 0x207
(1) Sensor Type	Sense Resistor	5	11101	1 1 1 0 1			
(2) Sense Resistor Value	5000.2Ω	27	000010011100010000011001100		0 0 0 0 1 0 0 1 1 1 0	0 0 1 0 0 0 0 0 1 1 0 0 1 1 0 0	

APPLICATIONS INFORMATION

Example: 4-Wire RTD with Rotation

One method to improve the accuracy of an RTD over the standard 4-wire implementation is by rotating the excitation current source. Parasitic thermocouple effects are automatically removed through autorotation. In order to perform autorotation, the 1st terminal of the RTD ties to CH_{RTD+1} instead of GND, as in the standard case. This allows the LTM2985 to automatically change the direction of the current source without the need for additional external components.

4-wire RTD with rotation channel assignments follow the general convention shown in Figure 19. Terminal 1 is tied to CH_{RTD+1} , terminals 2 and 3 (Kelvin sensed signal) tie to CH_{RTD} and CH_{RTD-1} and the 4th terminal ties to the sense resistor. Channel assignment data (see Table 29) is mapped to memory locations corresponding to CH_{RTD} .

Sense resistor channel assignments follow the general convention shown in Figure 20. The sense resistor is tied between CH_{RSENSE} and $CH_{RSENSE-1}$, where CH_{RSENSE} is tied to the 4th terminal of the RTD. Channel assignment

data is mapped into a memory location corresponding to CH_{RSENSE} .

Figure 21 shows a typical temperature measurement system using a rotating 4-wire RTD. In this example a 4-wire RTD's terminals tie to CH10, CH9, CH8 and CH6. The sense resistor is tied to CH6 and CH5. The sense resistor and RTD connect together at CH6. The RTD sensor type and configuration data are assigned to CH9. 32 bits of binary configuration data are mapped directly into memory locations 0x220 to 0x223 (see Table 47). The sense resistor is assigned to CH6. The user programmable value of this resistor is 10.0102kΩ. 32 bits of binary configuration data are mapped directly into memory locations 0x214 to 0x217 (see Table 48).

A conversion is initiated on CH9 by writing 10001001 into memory location 0x000. Once the conversion is complete, the INT pin goes HIGH and memory location 0x000 becomes 01001001. The resulting temperature in °C can be read from memory locations 0x030 to 0x033 (corresponding to CH9).

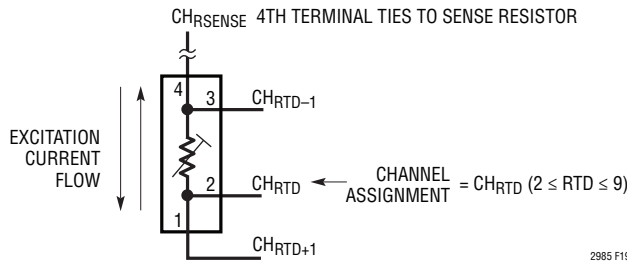

Figure 19. 4-Wire RTD Channel Assignment Convention

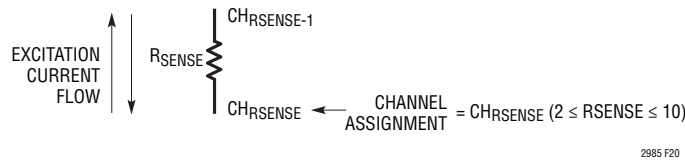

Figure 20. Sense Resistor Channel Assignment Convention for 4-Wire RTDs with Rotation

APPLICATIONS INFORMATION

Example: Multiple 4-Wire RTDs with Shared R_{SENSE}

Figure 22 shows a typical temperature measurement system using two 4-wire RTDs with a shared R_{SENSE}. The LTM2985 can support up to two 4-wire RTDs with a single sense resistor. In this example, the first 4-wire RTD's terminals tie to CH5, CH4, CH3 and CH2 and the 2nd ties to CH8, CH7, CH6 and CH2. The sense resistor ties to CH1 and CH2. The sense resistor and both RTDs connect together at CH2. This channel assignment convention is identical to that of the rotating RTD. This topology

supports both rotated and non-rotated RTD excitations. Channel assignment data for each sensor is shown in Table 49 to Table 51.

A conversion is initiated on CH4 by writing 10000100 into memory location 0x000. Once the conversion is complete, the INT pin goes HIGH and memory location 0x000 becomes 01000100. The resulting temperature in °C can be read from memory locations 0x01C to 0x01F (corresponding to CH4). A conversion can be initiated and read from CH7 in a similar fashion.

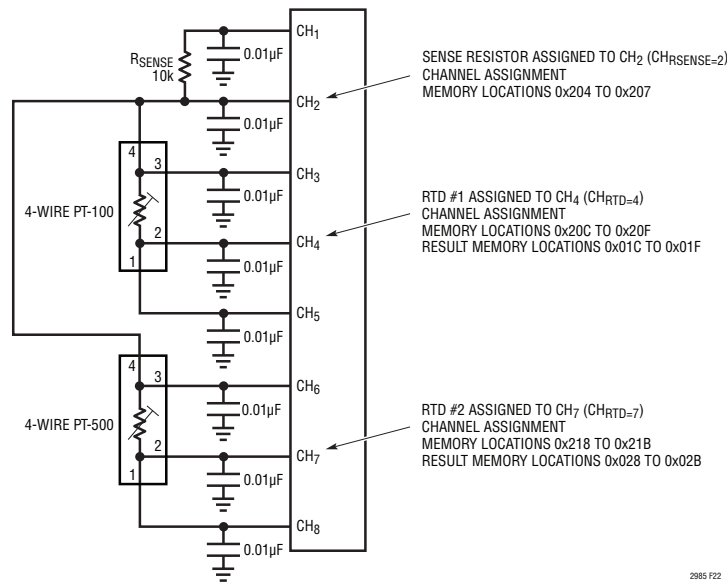

Figure 22. Shared R_{SENSE} 4-Wire RTD Example

Table 49. Channel Assignment Data for 4-Wire RTD #1 (PT-100, R_{SENSE} on CH₂, 4-Wire, Shared R_{SENSE}, Rotated 100µA Excitation Current, $\alpha = 0.003926$ Curve)

CONFIGURATION FIELD	DESCRIPTION	# BITS	BINARY DATA	MEMORY ADDRESS 0x20C	MEMORY ADDRESS 0x20D	MEMORY ADDRESS 0x20E	MEMORY ADDRESS 0x20F
(1) RTD TYPE	PT-100	5	01100	0 1 1 0 0			
(2) Sense Resistor Channel Pointer	CH ₂	5	00010		0 0 0 1 0		
(3) Sensor Configuration	4-Wire Rotated	4	1010		1 0 1 0		
(4) Excitation Current	100µA	4	0101			0 1 0 1	
(5) Curve	ITS-90, $\alpha = 0.003926$	2	11			1 1	
(6) Custom RTD Data Pointer	Not Custom	12	000000000000				0 0 0 0 0 0 0 0 0 0 0 0

APPLICATIONS INFORMATION

Table 50. Channel Assignment Data for 4-Wire RTD #2 (PT-500, R_{SENSE} on CH₂, 4-Wire, Rotated 50 μ A Excitation Current, $\alpha = 0.003911$ Curve)

CONFIGURATION FIELD	DESCRIPTION	# BITS	BINARY DATA	MEMORY ADDRESS 0x218	MEMORY ADDRESS 0x219	MEMORY ADDRESS 0x21A	MEMORY ADDRESS 0x21B
(1) RTD TYPE	PT-500	5	01110	0 1 1 1 0			
(2) Sense Resistor Channel Pointer	CH ₂	5	00010		0 0 0 1 0		
(3) Sensor Configuration	4-Wire Shared, No Rotation	4	1001		1 0 0 1		
(4) Excitation Current	50 μ A	4	0100			0 1 0 0	
(5) Curve	American, $\alpha = 0.003911$	2	01			0 1	
(6) Custom RTD Data Pointer	Not Custom	12	000000000000				0 0 0 0 0 0 0 0 0 0 0 0

Table 51. Channel Assignment Data for Sense Resistor (Value = 10.000k Ω)

CONFIGURATION FIELD	DESCRIPTION	# BITS	BINARY DATA	MEMORY ADDRESS 0x204	MEMORY ADDRESS 0x205	MEMORY ADDRESS 0x206	MEMORY ADDRESS 0x207
(1) Sensor Type	Sense Resistor	5	11101	1 1 1 0 1			
(2) Sense Resistor Value	10.000k Ω	27	0001001110001000000000000000		0 0 0 1 0 0 1 1 1 0 0 0 1 0 0 0 0 0 0 0 0 0 0 0 0 0 0		

APPLICATIONS INFORMATION

Example: 4-Wire RTD with Kelvin R_{SENSE}

It is possible to cancel the parasitic lead resistance in the sense resistors by configuring the 4-wire RTD with a 4-wire (Kelvin connected) sense resistor. This is useful when using a PT-10 or PT-50 with a small valued R_{SENSE} or when the sense resistor is remotely located or in applications requiring extreme precision.

The 4-wire RTD channel assignments follow the general conventions previously defined (Figure 19) for a standard 4-wire RTD. The sense resistor follows the convention shown in Figure 23.

Figure 24 shows a typical temperature measurement system using a 4-wire RTD with a Kelvin connected R_{SENSE} . In this example, the 4-wire RTD's terminals tie to CH10, CH9, CH8 and CH6. The sense resistor ties to CH6, CH5

and CH4 and excitation current is applied to CH4 and CH10. The sense resistor's nominal value is $1k\Omega$ in order to accommodate a 1mA excitation current. The sense resistor and RTD connect together at CH6. This topology supports rotated, shared and standard 4-wire RTD topologies. If rotated or shared configuration are not used then terminal 1 of the RTD is tied to ground instead of CH10, freeing up one input channel. Channel assignment data is shown in Tables 52 and 53.

A conversion is initiated on CH9 by writing 10001001 into memory location 0x000. Once the conversion is complete, the INT pin goes HIGH and memory location 0x000 becomes 01001001 (see Table 6). The resulting temperature in $^{\circ}C$ can be read from memory locations 0x030 to 0x033 (corresponding to CH9).

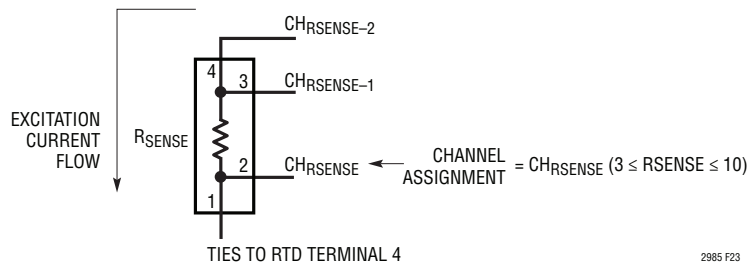

Figure 23. Sense Resistor with Kelvin Connections Channel Assignment Convention

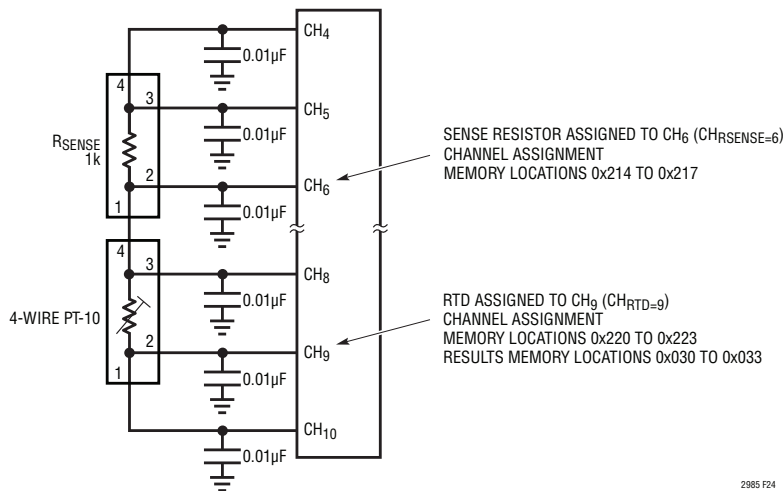

Figure 24. Sense Resistor with Kelvin Connections Example

APPLICATIONS INFORMATION

THERMISTOR MEASUREMENTS

Channel Assignment – Thermistor

For each thermistor tied to the LTM2985, a 32-bit channel assignment word is programmed into a memory location corresponding to the channel the sensor is tied to (see Table 54). This data includes (1) thermistor type, (2) sense resistor channel pointer, (3) sensor configuration, (4) excitation current, (5) Steinhart-Hart address pointer or custom table address pointer.

(1) Thermistor Type

The thermistor type is determined by the first five input bits (B31 to B27) as shown in Table 55. Linearization coefficients based on Steinhart-Hart equation for com-

monly used Thermistor types 44004/44033, 44005/44030, 44006/44031, 44007/44034, 44008/44032 and YSI-400 are built into the device. If other custom thermistors are used, Thermistor Custom Steinhart-Hart or Thermistor Custom Table (temperature vs resistance) can be selected. In this case, user specific data can be stored in the on-chip RAM starting at the address defined in Thermistor Custom Steinhart-Hart or Thermistor Custom Table address pointers.

(2) Sense Resistor Channel Pointer

Thermistor measurements are performed ratiometrically relative to a known R_{SENSE} resistor. The sense resistor channel pointer field indicates the differential channel the sense resistor is tied to for the current thermistor (see Table 31).

Table 54. Thermistor Channel Assignment Word

	(1) THERMISTOR TYPE					(2) SENSE RESISTOR CHANNEL POINTER					(3) SENSOR CONFIGURATION			(4) EXCITATION CURRENT				(5) CUSTOM THERMISTOR DATA POINTER																			
	TABLE 55					TABLE 31					TABLE 56			TABLE 57				TABLES 96, 97, 98, 100, 101																			
Measurement Class	31	30	29	28	27	26	25	24	23	22	21	20	19	18	17	16	15	14	13	12	11	10	9	8	7	6	5	4	3	2	1	0					
Thermistor	Type = 19 to 27					R_{SENSE} Channel Pointer [4:0]					SGL = 1 DIFF = 0			Excitation Mode				Excitation Current [3:0]				Not Used 0 0 0				Custom Address [5:0]					Custom Length –1 [5:0]						

Table 55. Thermistor Type: $1/T = A + B \cdot \ln(R) + C \cdot \ln(R)^2 + D \cdot \ln(R)^3 + E \cdot \ln(R)^4 + F \cdot \ln(R)^5$

B31	B30	B29	B28	B27	THERMISTOR TYPE	A	B	C	D	E	F
1	0	0	1	1	Thermistor 44004/44033 2.252k Ω at 25°C	1.46800E-03	2.38300E-04	0	1.00700E-07	0	0
1	0	1	0	0	Thermistor 44005/44030 3k Ω at 25°C	1.40300E-03	2.37300E-04	0	9.82700E-08	0	0
1	0	1	0	1	Thermistor 44007/44034 5k Ω at 25°C	1.28500E-03	2.36200E-04	0	9.28500E-08	0	0
1	0	1	1	0	Thermistor 44006/44031 10k Ω at 25°C	1.03200E-03	2.38700E-04	0	1.58000E-07	0	0
1	0	1	1	1	Thermistor 44008/44032 30k Ω at 25°C	9.37600E-04	2.20800E-04	0	1.27600E-07	0	0
1	1	0	0	0	Thermistor YSI-400 2.252k Ω at 25°C	1.47134E-03	2.37624E-04	0	1.05034E-07	0	0
1	1	0	0	1	Spectrum 1003k 1k Ω at 25°C	1.445904E-3	2.68399E-04	0	1.64066E-07	0	0
1	1	0	1	0	Thermistor Custom Steinhart-Hart	user input	user input	user input	user input	user input	user input
1	1	0	1	1	Thermistor Custom Table	not used	not used	not used	not used	not used	not used

APPLICATIONS INFORMATION

(3) Sensor Configuration

The sensor configuration field is used to define various thermistor properties. Configuration bit B21 is set high for single-ended (measurement relative to COM) and low for differential (see Table 56).

Table 56. Sensor Configuration Data

(3) SENSOR CONFIGURATION			SINGLE-ENDED/ DIFFERENTIAL	SHARE R _{SENSE}	ROTATE
SGL	EXCITATION MODE				
B21	B20	B19			
0	0	0	Differential	No	No
0	0	1	Differential	Yes	Yes
0	1	0	Differential	Yes	No
0	1	1		Reserved	
1	0	0	Single-Ended	No	No
1	0	1		Reserved	
1	1	0		Reserved	
1	1	1		Reserved	

The next sensor configuration bits (B19 and B20) determine the excitation current mode. These bits are used to enable R_{SENSE} sharing, where one sense resistor is used for multiple thermistors. In this case, the thermistor ground connection is internal and each thermistor points to the same R_{SENSE} channel.

Bits B19 and B20 are also used to enable excitation current rotation to automatically remove parasitic thermocouple effects. Parasitic thermocouple effects may arise from the physical connection between the thermistor and the measurement instrument. This mode is available for differential thermistor configurations using internal current source excitation.

(4) Excitation Current

The next field in the channel assignment word (B18 to B15) controls the magnitude of the excitation current applied to the thermistor (see Table 57). In order to prevent hard or soft faults, select a current such that the maximum voltage drop across the sensor or sense resistor is nominally 1.0V. The LTM2985 has no special requirements related to the ratio between the voltage drop across the sense resistor and the sensor. Consequently, it is possible to have a sense resistor several orders of magnitude smaller than the maximum sensor value. For optimal performance over the full thermistor temperature range, auto ranged current can be selected. In this case, the LTM2985 conversion is performed in three cycles (instead of the standard two cycles) (see Table 83). The first cycle determines the optimal excitation current for the sensor resistance value and R_{SENSE} value. The following two cycles use that current to measure the thermistor temperature.

(5) Steinhart-Hart Address/Custom Table Address

See Custom Thermistors section near the end of this data sheet for more information.

Table 57. Excitation Current for Thermistors

(4) EXCITATION CURRENT				CURRENT
B18	B17	B16	B15	
0	0	0	0	Reserved
0	0	0	1	250nA
0	0	1	0	500nA
0	0	1	1	1μA
0	1	0	0	5μA
0	1	0	1	10μA
0	1	1	0	25μA
0	1	1	1	50μA
1	0	0	0	100μA
1	0	0	1	250μA
1	0	1	0	500μA
1	0	1	1	1mA
1	1	0	0	Auto Range*
1	1	0	1	Invalid
1	1	1	0	Invalid
1	1	1	1	External

*Auto Range not allowed for custom sensors.

*Additional Circuitry required for auto-range, see Figure 30.

APPLICATIONS INFORMATION

Fault Reporting – Thermistor

Each sensor type has unique fault reporting mechanism indicated in the upper byte of the data output word. Table 58 shows faults reported during the measurement of thermistors.

Bit D31 indicates the thermistor or R_{SENSE} is open, shorted, or not plugged in. This is a hard fault and -999°C is reported. Bit D30 indicates a bad ADC reading. This could be a result of either a broken (open) sensor or an excessive noise event (ESD or static discharge into the sensor path).

This is a hard error and -999°C is output. In the case of an excessive noise event, the device should recover and the following conversions will be valid if the noise event was a random infrequent event. Bits D29 and D28 are not used for thermistors. Bits D27 and D26 indicate the reading is over or under temperature limits (see Table 59). The calculated temperature is reported, but the accuracy may be compromised. Bit D25 indicates the absolute voltage measured by the ADC is beyond its normal operating range. If a thermistor is used as the cold junction element, any hard or soft error is flagged in the thermocouple result.

Table 58. Thermistor Fault Reporting

BIT	FAULT	ERROR TYPE	DESCRIPTION	OUTPUT RESULT
D31	Sensor Hard Fault	Hard	Open or Short Thermistor or R_{SENSE}	-999°C
D30	Hard ADC-Out-of-Range	Hard	Bad ADC Reading (Could Be Large External Noise Event)	-999°C
D29	Not Used for Thermistors	N/A	Always 0	Valid Reading
D28	Not Used for Thermistors	N/A	Always 0	Valid Reading
D27	Sensor Over Range*	Soft	$T > \text{High Temp Limit}$	Suspect Reading
D26	Sensor Under Range*	Soft	$T < \text{Low Temp Limit}$	Suspect Reading
D25	ADC Out-of-Range	Soft	ADC Absolute Input Voltage Is Beyond $\pm 1.125 \cdot V_{REF}/2$	Suspect Reading
D24	Valid	N/A	Result Valid (Should Be 1) Discard Results if 0	Valid Reading

*Do not apply to custom Steinhart-Hart sensor type. Custom table thermistor over/under range is determined by the resistor table values, see custom thermistor table example for details.

Table 59. Thermistor Temperature/Resistance Range

THERMISTOR TYPE	MIN (Ω)	MAX (Ω)	LOW Temp Limit ($^{\circ}\text{C}$)	HIGH Temp Limit ($^{\circ}\text{C}$)
Thermistor 44004/44033 2.252k Ω at 25 $^{\circ}\text{C}$	41.9	75.79k	-40	150
Thermistor 44005/44030 3k Ω at 25 $^{\circ}\text{C}$	55.6	101.0k	-40	150
Thermistor 44007/44034 5k Ω at 25 $^{\circ}\text{C}$	92.7	168.3k	-40	150
Thermistor 44006/44031 10k Ω at 25 $^{\circ}\text{C}$	237.0	239.8k	-40	150
Thermistor 44008/44032 30k Ω at 25 $^{\circ}\text{C}$	550.2	884.6k	-40	150
Thermistor YSI 400 2.252k Ω at 25 $^{\circ}\text{C}$	6.4	1.66M	-80	250
Spectrum 1003K 1k Ω at 25 $^{\circ}\text{C}$	51.1	39.51k	-50	125
Thermistor Custom Steinhart-Hart	N/A	N/A	N/A	N/A
Thermistor Custom Table	Second Table Entry	Last Table Entry		

APPLICATIONS INFORMATION

Example: Single-Ended Thermistor

The simplest thermistor configuration is the single-ended configuration. Thermistors using this configuration share a common ground (COM) between all sensors and are each tied to a unique sense resistor (R_{SENSE} sharing is not allowed for single-ended thermistors). Single-ended thermistors follow the convention shown in Figure 25. Terminal 1 ties to ground (COM) and terminal 2 ties to CH_{THERM} and the sense resistor. Channel assignment data (see Table 54) is mapped to memory locations corresponding to CH_{THERM} .

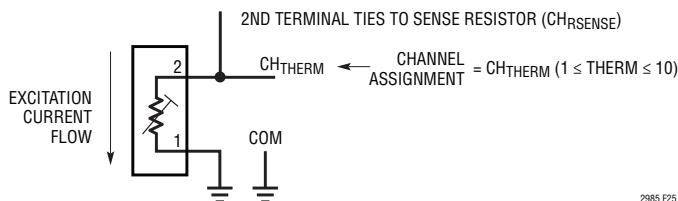

Figure 25. Single-Ended Thermistor Channel Assignment Convention

Sense resistor channel assignments follow the general convention shown in Figure 26. The sense resistor is tied between CH_{RSENSE} and $CH_{RSENSE-1}$, where CH_{RSENSE} is tied

to the 2nd terminal of the thermistor. Channel assignment data (see Table 37) is mapped into the memory location corresponding to CH_{RSENSE} .

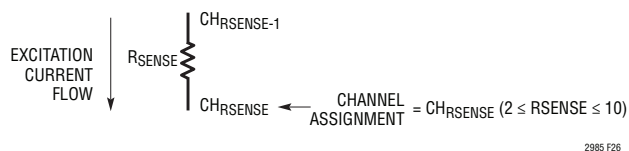

Figure 26. Sense Resistor Channel Assignment Convention

Figure 27 shows a typical temperature measurement system using a single-ended thermistor. In this example a 10kΩ (44031 type) thermistor is tied to a 10.1kΩ sense resistor. The thermistor is assigned channel CH5 (memory locations 0x210 to 0x213) and the sense resistor to CH4 (memory locations 0x20C to 0x20F). Channel assignment data are shown in Tables 60 and 61.

A conversion is initiated on CH5 by writing 10000101 into memory location 0x000. Once the conversion is complete, the INT pin goes HIGH and memory location 0x000 becomes 01000101. The resulting temperature in °C can be read from memory locations 0x020 to 0x023 (corresponding to CH5).

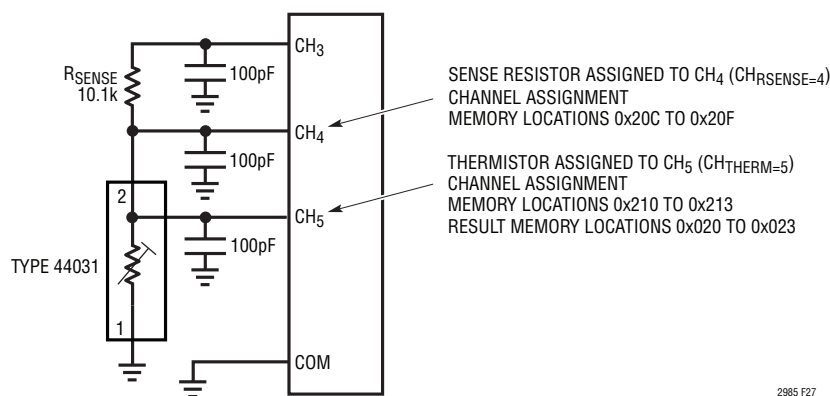

Figure 27. Single-Ended Thermistor Example

APPLICATIONS INFORMATION

Table 60. Channel Assignment Data for Single-Ended Thermistor (44006/44031 10kΩ at 25°C Type Thermistor, Single-Ended Configuration, R_{SENSE} on CH₄, 1μA Excitation Current)

CONFIGURATION FIELD	DESCRIPTION	# BITS	BINARY DATA	MEMORY ADDRESS 0x210	MEMORY ADDRESS 0x211	MEMORY ADDRESS 0x212	MEMORY ADDRESS 0x213
(1) Thermistor Type	44006/44031 10kΩ at 25°C	5	10110	1 0 1 1 0			
(2) Sense Resistor Channel Pointer	CH ₄	5	00100		0 0 1 0 0		
(3) Sensor Configuration	Single-Ended	3	100		1 0 0		
(4) Excitation Current	1μA	4	0011		0 0 1 1		
Not Used	Set These Bits to 0	3	000			0 0 0	
(5) Custom Thermistor Data Pointer	Not Custom	12	000000000000				0 0 0 0 0 0 0 0 0 0 0 0

Table 61. Channel Assignment Data for Sense Resistor (Value = 10.1kΩ)

CONFIGURATION FIELD	DESCRIPTION	# BITS	BINARY DATA	MEMORY ADDRESS 0x20C	MEMORY ADDRESS 0x20D	MEMORY ADDRESS 0x20E	MEMORY ADDRESS 0x20F
(1) Sensor Type	Sense Resistor	5	11101	1 1 1 0 1			
(2) Sense Resistor Value	10.1kΩ	27	00010011101110100000000000		0 0 0 1 0 0 1 1 1 0 1 1	1 0 1 0 0 0 0 0 0 0 0 0	0 0 0 0 0 0 0 0

APPLICATIONS INFORMATION

Example: Differential Thermistor

The differential thermistor configuration allows separate ground sensing for each sensor. In this standard differential configuration, one sense resistor is used for each thermistor. Differential thermistors follow the convention shown in Figure 28. Terminal 1 ties to CH_{THERM} and is shorted to ground and terminal 2 ties $CH_{THERM-1}$ to and the sense resistor. Channel assignment data (see Table 54) is mapped to memory locations corresponding to CH_{THERM} .

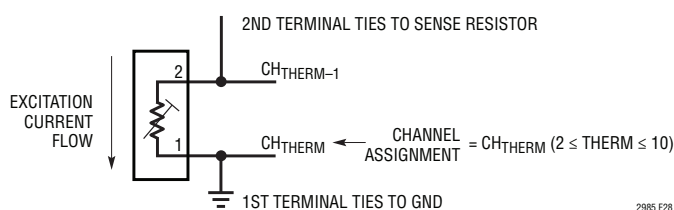

Figure 28. Differential Thermistor Channel Assignment Convention

Sense resistor channel assignments follow the general convention shown in Figure 29. The sense resistor is tied between CH_{RSENSE} and $CH_{RSENSE-1}$, where CH_{RSENSE} is tied to the 2nd terminal of the thermistor. Channel as-

ignment data (see Table 37) is mapped into a memory location corresponding to CH_{RSENSE} .

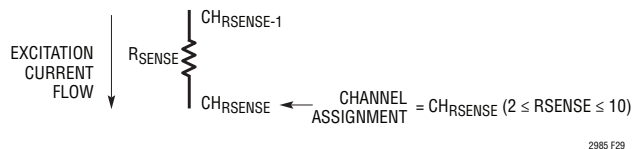

Figure 29. Sense Resistor Channel Assignment Convention

Figure 30 shows a typical temperature measurement system using a differential thermistor. In this example a $30k\Omega$ (44032 type) thermistor is tied to a $9.99k\Omega$ sense resistor. The thermistor is assigned channel CH_9 (memory locations $0x220$ to $0x223$) and the sense resistor to CH_7 (memory locations $0x218$ to $0x21B$). Channel assignment data is shown in Table 62 and Table 63).

A conversion is initiated on CH_9 by writing 10001001 into memory location $0x000$. Once the conversion is complete, the INT pin goes HIGH and memory location $0x000$ becomes 01001001 . The resulting temperature in $^{\circ}C$ can be read from memory locations $0x030$ to $0x033$ (Corresponding to CH_9).

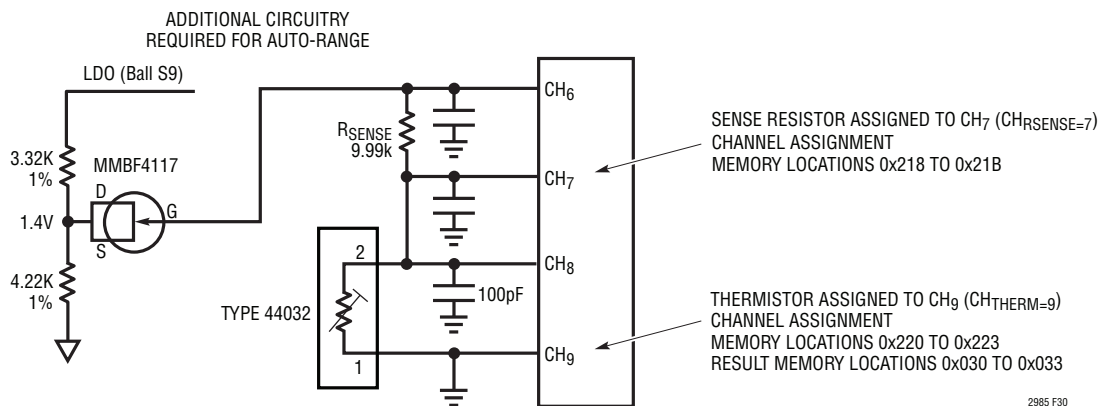

Figure 30. Differential Thermistor Example

APPLICATIONS INFORMATION

Table 62. Channel Assignment Data for Differential Thermistor (44008/44032 30kΩ at 25°C Type Thermistor, Differential Configuration, R_{SENSE} on CH₇, Auto Range Excitation)

CONFIGURATION FIELD	DESCRIPTION	# BITS	BINARY DATA	MEMORY ADDRESS 0x220	MEMORY ADDRESS 0x221	MEMORY ADDRESS 0x222	MEMORY ADDRESS 0x223
(1) Thermistor Type	44008/44032 30kΩ at 25°C	5	10111	1 0 1 1 1			
(2) Sense Resistor Channel Pointer	CH ₇	5	00111		0 0 1 1 1		
(3) Sensor Configuration	Differential, No Share, No Rotate	3	000		0 0 0		
(4) Excitation Current	Auto Range See Note 1	4	1100		1 1 0 0		
Not Used	Set These Bits to 0	2	000			0 0 0	
(5) Custom Thermistor Data Pointer	Not Custom	12	000000000000				0 0 0 0 0 0 0 0 0 0 0 0

Note 1: Additional Circuitry required for thermistors using auto-range. See Figure 30.

Table 63. Channel Assignment Data for Sense Resistor (Value = 9.99kΩ)

CONFIGURATION FIELD	DESCRIPTION	# BITS	BINARY DATA	MEMORY ADDRESS 0x218	MEMORY ADDRESS 0x219	MEMORY ADDRESS 0x21A	MEMORY ADDRESS 0x21B
(1) Sensor Type	Sense Resistor	5	11101	1 1 1 0 1			
(2) Sense Resistor Value	9.99kΩ	27	00010011100000110000000000		0 0 0 1 0 0 1 1 1 0 0 0 0 0 0 0 0 1 1 0 0 0 0 0 0 0 0		

APPLICATIONS INFORMATION

Example: Shared/Rotated Differential Thermistor

The differential thermistor configuration allows separate internal ground sensing for each sensor. In this configuration, one sense resistor can be used for multiple thermistors. Differential thermistors follow the convention shown in Figure 31. Terminal 1 ties to CH_{THERM} and terminal 2 ties to $CH_{THERM-1}$ and the sense resistor. Channel assignment data (see Table 54) is mapped to memory locations corresponding to CH_{THERM} .

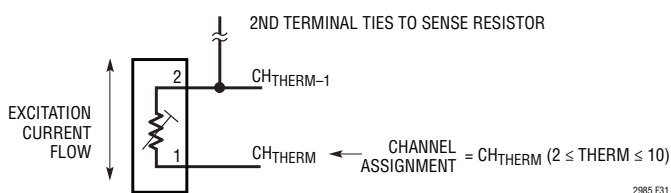

Figure 31. Thermistor with Shared R_{SENSE} Channel Assignment Convention

Sense resistor channel assignments follow the general convention shown in Figure 32. The sense resistor is tied between CH_{RSENSE} and $CH_{RSENSE-1}$, where CH_{RSENSE} is tied to the 2nd terminal of the thermistor. Channel assignment data (see Table 37) is mapped into a memory location corresponding to CH_{THERM} .

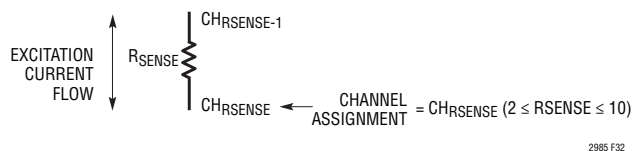

Figure 32. Sense Resistor Channel Assignment Convention for Thermistors

Figure 33 shows a typical temperature measurement system using a shared sense resistor and one rotated/non-rotated differential thermistors. In this example a $30k\Omega$ (44032 Type) thermistor is tied to a $10.0k\Omega$ sense resistor and configured as rotated/shared. The second thermistor a $2.25k\Omega$ (44033 type) is configured as a non-rotated/shared. Channel assignment data are shown in Tables 64 to 66.

A conversion is initiated on CH8 by writing 10001000 into memory location 0x000. Once the conversion is complete, the INT pin goes HIGH and memory location 0x000 becomes 01001000. The resulting temperature in $^{\circ}C$ can be read from memory locations 0x02C to 0x02F (corresponding to CH8). A conversion can be initiated and read from CH10 in a similar fashion.

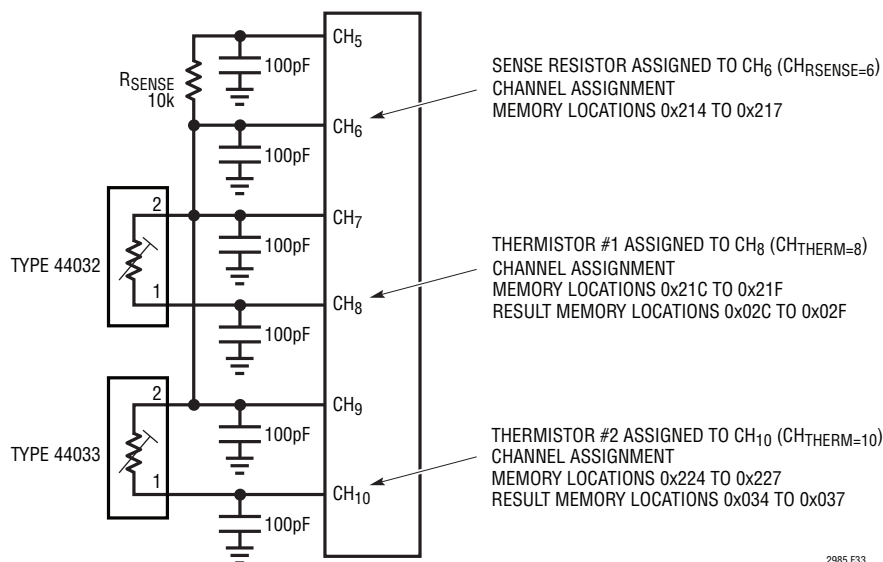

Figure 33. Rotated and Shared Thermistor Example

APPLICATIONS INFORMATION

Table 64. Channel Assignment Data Differential Thermistor (44008/44032 30kΩ at 25°C Type Thermistor, Differential Configuration with Sharing and Rotation, R_{SENSE} on CH₆, 250nA Excitation Current)

CONFIGURATION FIELD	DESCRIPTION	# BITS	BINARY DATA	MEMORY ADDRESS 0x21C	MEMORY ADDRESS 0x21D	MEMORY ADDRESS 0x21E	MEMORY ADDRESS 0x21F
(1) Thermistor Type	44008/44032 30kΩ at 25°C	5	10111	1 0 1 1 1			
(2) Sense Resistor Channel Pointer	CH ₆	5	00110		0 0 1 1 0		
(3) Sensor Configuration	Differential, Rotate and Shared	3	001		0 0 1		
(4) Excitation Current	250nA Excitation Current	4	0001		0 0 0 1		
Not Used	Set These Bits to 0	3	000			0 0 0	
(5) Custom Thermistor Data Pointer	Not Custom	12	000000000000				0 0 0 0 0 0 0 0 0 0 0 0

Table 65. Channel Assignment Data Differential Thermistor (44004/44033 2.252kΩ at 25°C Type Thermistor, Differential Configuration with Sharing and No Rotation, R_{SENSE} on CH₆, 10μA Excitation Current)

Configuration Field	Description	# Bits	Binary Data	MEMORY ADDRESS 0x224	MEMORY ADDRESS 0x225	MEMORY ADDRESS 0x226	MEMORY ADDRESS 0x227
(1) Thermistor Type	44004/44033 2.252kΩ at 25°C	5	10011	1 0 0 1 1			
(2) Sense Resistor Channel Pointer	CH ₆	5	00110		0 0 1 1 0		
(3) Sensor Configuration	Differential, No Rotate and Shared	3	010		0 1 0		
(4) Excitation Current	10μA Excitation Current	4	0101		0 1 0 1		
Not Used	Set These Bits to 0	3	000			0 0 0	
(5) Custom RTD Data Pointer	Not Custom	12	000000000000				0 0 0 0 0 0 0 0 0 0 0 0

Table 66. Channel Assignment Data for Sense Resistor (Value = 10.0kΩ)

Configuration Field	Description	# Bits	Binary Data	MEMORY ADDRESS 0x214	MEMORY ADDRESS 0x215	MEMORY ADDRESS 0x216	MEMORY ADDRESS 0x217
(1) Sensor Type	Sense Resistor	5	11101	1 1 1 0 1			
(2) Sense Resistor Value	10.0kΩ	27	0001001110001000000000000000		0 0 0 1 0 0 1 1 1 0 0 0 1 0 0 0 0 0 0 0 0 0 0 0 0 0 0		

APPLICATIONS INFORMATION

GLOBAL CONFIGURATION REGISTER

Table 67 shows a summary of the global configuration register. The global configuration register is 1 byte long and is at memory location 0x0F0. Bits G0 – G1 set the notch frequency of the on chip digital filter, Bit G2 sets the temperature results unit (°C or °F), Bits G3 and G7 are reserved and should be set low, Bits G4 – G6 determine the Kelvin current excitation mode.

Table 67. Global Configuration Register

BIT #	FIELD NAME	DESCRIPTION
G0 G1	Filter Frequency Select [1:0]	00 = 55Hz 01 = 60Hz 10 = 50Hz
G2	Temperature Result Format	0 = Celsius 1 = Fahrenheit
G3	Reserved	Set to 0
G4	3-Wire RTD Kelvin Current Excitation Mode	Excitation Current on Adjacent Channels
G5	2-Wire RTD Kelvin Current Excitation Mode	Excitation Current on Adjacent Channels
G6	Thermistor Kelvin Current Excitation Mode	Excitation Current on Adjacent Channels
G7	Reserved	Set to 0

INPUT OVERVOLTAGE PROTECTION – OVERVIEW

Temperature sensors are often used in harsh environments. The sensors or leads can short to high voltages or each other. Resistive circuits can protect the LTM2985 from these fault conditions. These external resistors can potentially introduce measurement errors; however, the LTM2985 includes special modes and features that reduce these effects

The tip of a thermocouple is often unshielded, creating a low impedance conductive path to the input of the measurement device. In order to protect the LTM2985 from damage due to overvoltage conditions, current-limiting resistors can be placed between the input channels and the thermocouple sensor. The value of this resistor is chosen such that at the maximum overvoltage, the current entering the LTM2985 is less than ±15mA. Errors due to these protection resistors are minimal during normal operation due to the very low input leakage (1nA) specifications of the LTM2985.

Most RTD sensor elements are electrically isolated from the sensor leads either through a non-conductive encapsulation or a separate grounding shield. While these types of sensors may not require input overvoltage protection, certain applications may require current limiting resistors between the RTD and the LTM2985. One such application is a universal input device where an input terminal can see either an RTD or a thermocouple. Other applications may require protection against erroneous connections, for example, connecting a voltage source accidentally to the RTD input terminals. The protection circuits implemented for RTDs should accommodate 2-wire, 3-wire and 4-wire configurations.

Thermistors are 2-wire resistance to temperature sensors with a non-conductive encapsulation enclosing the sensor element. Similar to the RTD, overvoltage protection for thermistors may be required for both universal sensor input applications and inadvertent user applied overvoltage.

The LTM2985 offers several current excitation modes for eliminating errors due to resistive overvoltage protection circuits. The following sections describe overvoltage protection circuits for thermocouples, 2-, 3- and 4-wire RTDs and thermistors with an emphasis on universality (sharing the same protection scheme for all sensor types).

Input Overvoltage Protection – Resistor Value Selection

The maximum continuous current the LTM2985 can sustain without damage is ±15mA. In order to determine the value of the overvoltage protection resistor and its power rating, the maximum voltage is required. This voltage is application specific and depends on the maximum anticipated overvoltage. For example, a system with possible overvoltage of 40V would require a resistance $R > 2.7k\Omega$ and a power rating (see Figure 34 and Figure 35):

$$P > 600\text{mW, where } R > \frac{V_{\text{MAX}} - V_{\text{CC2}}}{15\text{mA}}$$

APPLICATIONS INFORMATION

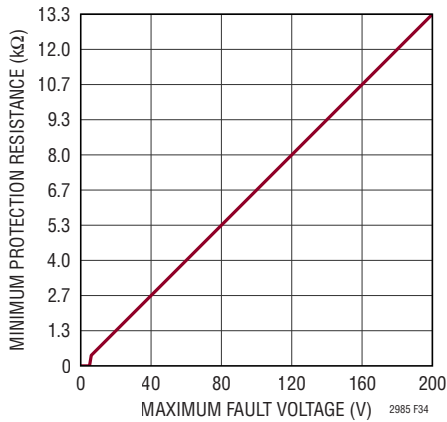

Figure 34. Maximum Fault Voltage vs Minimum Protection Resistance

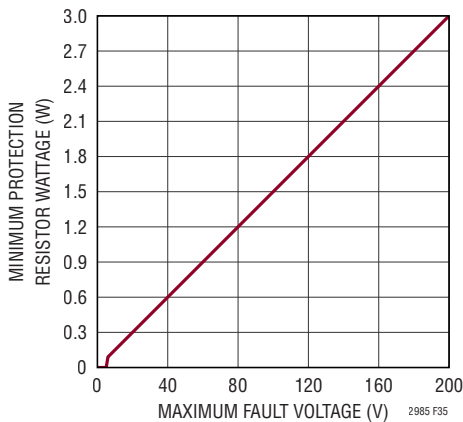

Figure 35. Maximum Fault Voltage vs Minimum Protection Resistor Power Rating

Input Overvoltage Protection – Thermocouples

Thermocouples are low impedance devices that generate voltage as a function of temperature differences. Since the LTM2985 input impedance is very high (input leakage < 1nA) external overvoltage protection resistors have minimal effect on the temperature measurement accuracy. For example, a 2kΩ protection resistor results in a worst-case error of 4μV (see Figure 36). This corresponds to a 0.1°C error for a Type K thermocouple at 25°C.

In addition to the protection resistors, 100pF capacitors should be added to each input for anti-alias filtering; these are not shown in the following schematics for simplicity.

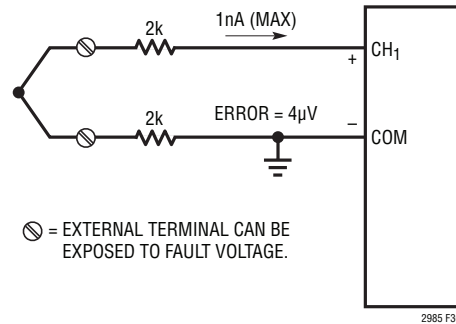

Figure 36. Thermocouple with Protection Resistors

Input Overvoltage Protection – RTDs

RTDs are resistive devices that require excitation current in order to determine their temperature. The excitation is applied to the series network consisting of the RTD and a sense resistor in order to make a ratiometric measurement. Overvoltage protection is implemented by placing a resistor between each RTD terminal and the LTM2985 input channels.

4-Wire RTDs

The simplest RTD configuration to protect is the 4-wire RTD. A protection resistor is tied to each of the 4 RTD terminals (see Figure 37). Excitation current flows through the sense resistor (R_{SENSE}), the RTD and protection resistors RP1 and RP4. The LTM2985 measures the voltage drop across the RTD using CH3 and CH4 through protection resistors RP2 and RP3. Since the excitation current does not flow through RP2 and RP3, errors due to the protection resistance are negligible. Measurement errors are dominated by input leakage current ($I < 1nA$). For example, errors due to leakage current for a PT-100 RTD with 1kΩ sense resistor and 1kΩ protection resistors are below 0.025°C.

APPLICATIONS INFORMATION

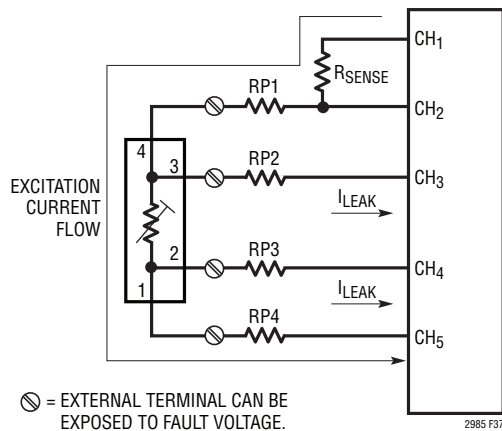

Figure 37. 4-Wire RTD with Protection Resistors

3-Wire RTDs

3-wire RTDs are more difficult to protect than 4-wire RTDs. Normally, protection resistors are tied to each of the 3 RTD terminals (see Figure 38). The LTM2985 provides two matched excitation currents, I_1 and I_2 . These currents flow from CH3 and CH4 through RP2 and RP3 into the RTD. The resulting voltage is measured between CH3 and CH4. Assuming $RP2 = RP3$ and $I_1 = I_2$, the errors resulting from the protection resistors are cancelled. While the LTM2985 provides matched current source excitation, external protection resistors may be difficult to match. Every 1Ω mismatch in $RP2$ and $RP3$ translates to a 1Ω error in the RTD measurement.

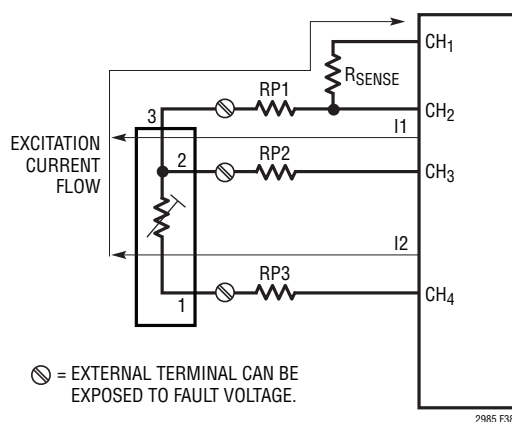

Figure 38. 3-Wire RTD with Protection Resistors

The LTM2985 offers a 3-wire RTD Kelvin current source mode in order to remove errors due to mismatched protection resistors. This feature is enabled by setting the global 3-wire RTD Kelvin current excitation mode bit ($G4 = 1$, see Table 67) prior to initiating a conversion start. This mode uses the adjacent channels (in this example CH5 and CH6) for the current source excitation and performs the measurement on CH3 and CH4 (see Figure 39). Two additional resistors are placed between the RTD and the channels tied to the excitation current sources, but the protection resistor matching constraint is removed for all resistors. The excitation current no longer flows through $RP2$ or $RP3$, removing the voltage drop across them. Figure 40 shows the channel assignment convention for this mode.

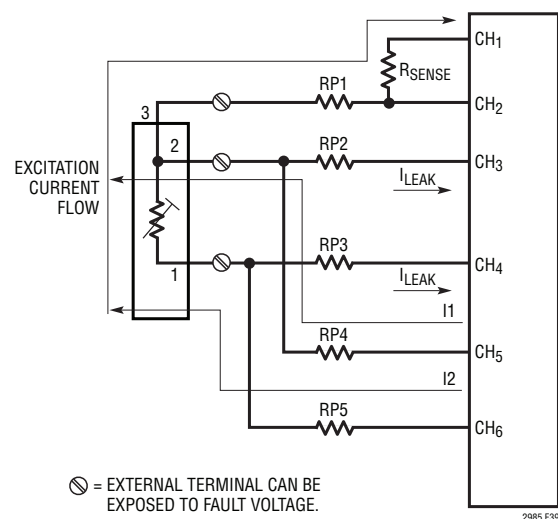

Figure 39. 3-Wire RTD Kelvin Current Mode ($G4 = 1$)

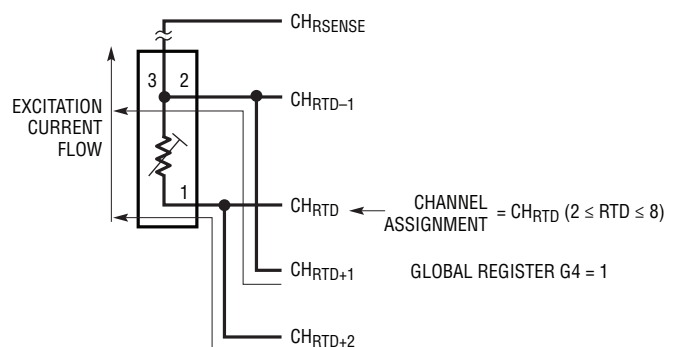

Figure 40. 3-Wire RTD Kelvin Current Mode Channel Assignment Convention ($G4 = 1$)

APPLICATIONS INFORMATION

2-Wire RTDs

2-wire RTDs are difficult to protect because the protection resistor (RP3) is in series with the RTD (see Figure 41). Every 1Ω of protection resistance adds 1Ω measurement error to the RTD.

The LTM2985 offers a 2-wire Kelvin current source mode in order to remove the errors associated with protection resistors. This feature is enabled by setting the global 2-wire RTD Kelvin current excitation mode bit (G5 = 1, see Table 67) prior to initiating a conversion start. This current excitation mode uses the adjacent channel (CH5 for this example) for the internal ground connection (see Figure 42). One additional protection resistor is added between the RTD and CH5. The excitation current no longer flows through RP3, removing the voltage drop across it. Figure 43 shows the channel assignment convention for this mode.

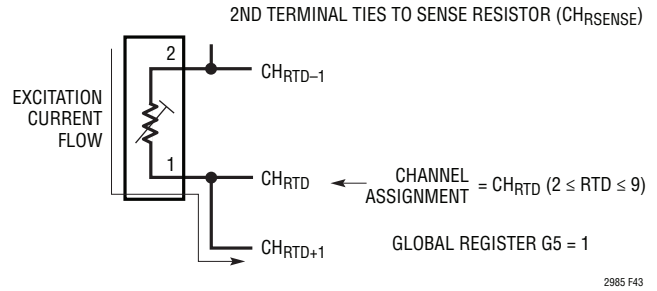

Figure 43. 2-Wire Kelvin Current Mode Channel Assignment Convention (G5 = 1)

Thermistors

Similar to the 2-wire RTD, thermistors are difficult to protect because the protection resistor RP3 is in series with the sensor (see Figure 44). Every 1Ω of protection resistance adds 1Ω measurement error to the thermistor.

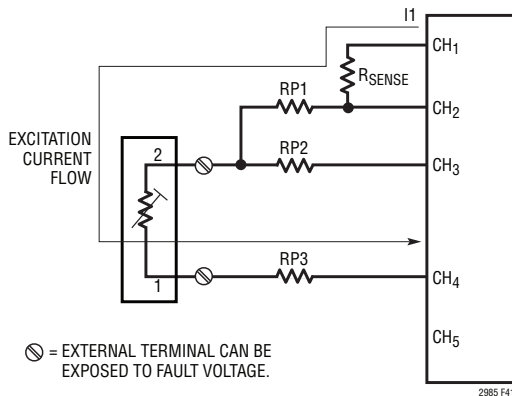

Figure 41. 2-wire RTD with Protection Resistors

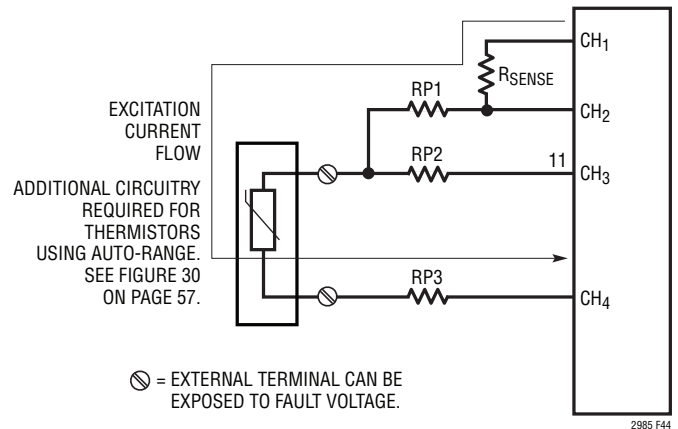

Figure 44. Thermistor with Protection Resistors

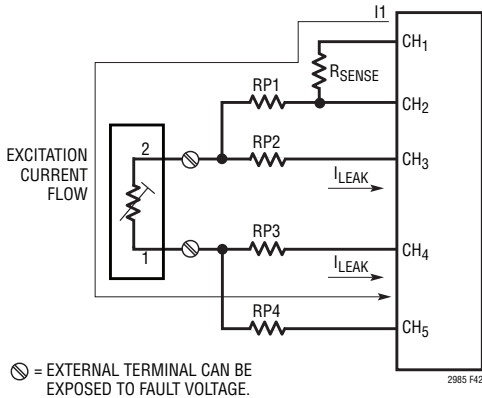

Figure 42. 2-Wire RTD Kelvin Current Mode (G5 = 1)

The LTM2985 offers a thermistor Kelvin current source mode in order to remove the errors associated with protection resistors. This feature is enabled by setting the global thermistor Kelvin current excitation mode bit (G6 = 1, see Table 67) prior to initiating a conversion start. This current excitation mode uses the adjacent channel (CH5 for this example) for the internal ground connection (see Figure 45). One additional protection resistor is added between the thermistor and CH5. The excitation current no longer flows through RP3, removing the voltage drop across it. Figure 46 shows the channel assignment convention for this mode.

APPLICATIONS INFORMATION

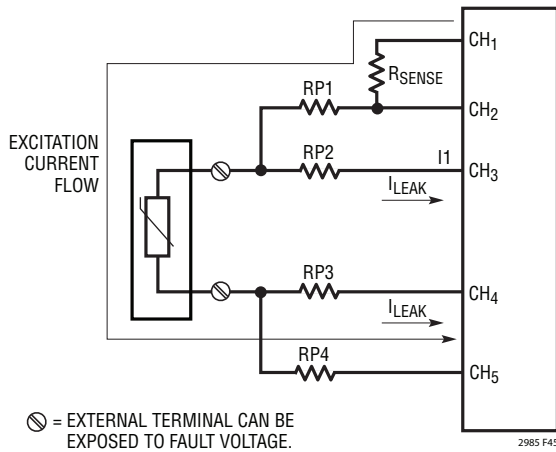

Figure 45. Thermistor Kelvin Current Source Mode (G6 = 1)

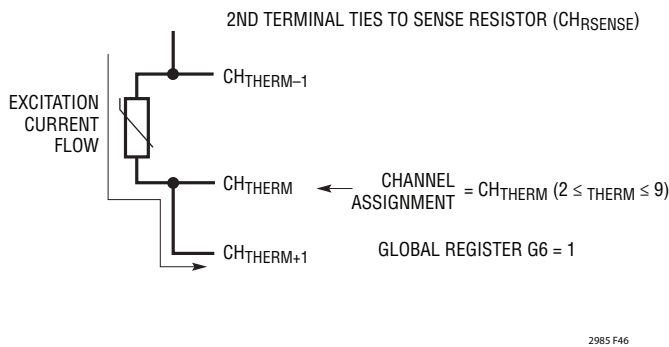

Figure 46. Thermistor Kelvin Current Mode Channel Assignment Convention (G6 = 1)

Universal Example

The LTM2985 is capable of sharing one protected interface with multiple sensor types (see Figure 47). This includes all RTD configurations (2-, 3- and 4-wire), thermistors and thermocouples. Switching between sensors only requires a new channel assignment word via software control. The multi-sensor circuit provides 4 input terminals, each protected against external overvoltage conditions. In order to enable Kelvin current excitation mode for all sensors set all 3 global configuration bits G4, G5 and G6 to 1 (see Table 67).

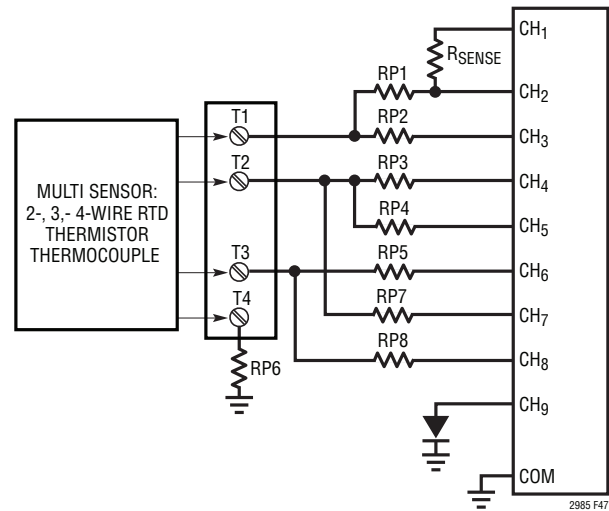

Figure 47. Universal Multi-Sensor Schematic

In Figure 48, a 4-wire RTD is tied directly to the 4 input terminals. In this case, the 4-wire RTD is assigned to CH6 and the sense resistor is tied to CH2. The excitation current flows through protection resistors RP1 and RP6. Since RP6 is grounded, R_SENSE sharing and excitation current rotation are off.

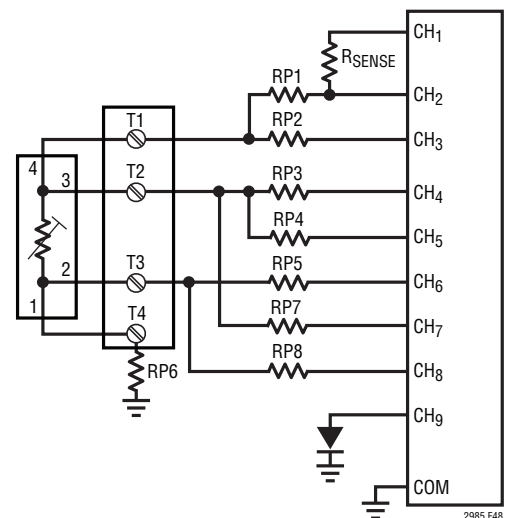

Figure 48. Protected Multi-Sensor 4-Wire RTD Connection

APPLICATIONS INFORMATION

Figure 49 shows the interface to a 3-wire RTD using the multi-sensor circuit. In this case, the RTD ties directly to terminals T1 – T3 and terminal T4 is left floating. Matched excitation currents flow from CH7 and CH8 through protection resistors RP7 and RP8 while the RTD measurement occurs at CH5 and CH6. The 3-wire RTD is assigned to CH6 and R_{SENSE} sharing is turned on.

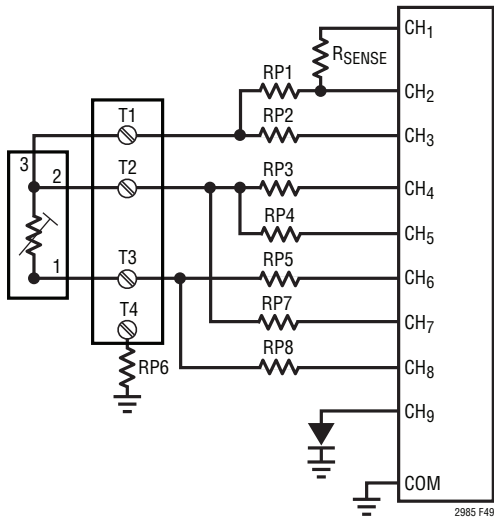

Figure 49. Protected Multi-Sensor 3-Wire RTD Connection

Figure 50 shows the interface to a 2-wire RTD using the LTM2985 multi-sensor circuit. In this case, the RTD ties directly to terminals T1 and T2 while terminals T3 and T4 are left floating. The excitation current flows from CH1 through R_{SENSE} and protection resistors RP1 and RP4 (CH5 is internally grounded) while the RTD measurement occurs at CH3 and CH4. The 2-wire RTD is assigned to CH4 and R_{SENSE} sharing is turned on.

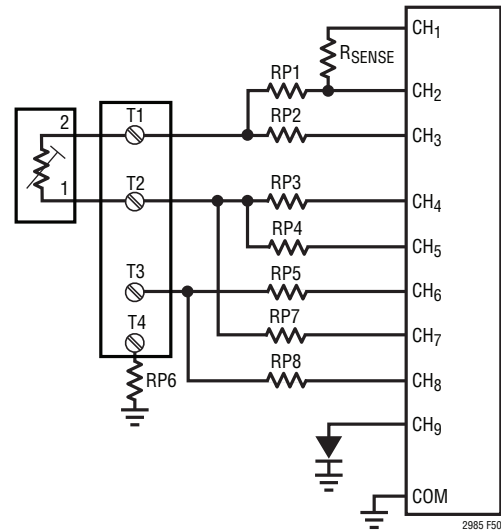

Figure 50. Protected Multi-Sensor 2-Wire RTD Connection

Figure 51 shows the interface to a thermistor using the LTM2985 multi-sensor circuit. In this case, the thermistor ties directly to terminals T1 and T2 while terminals T3 and T4 are left floating. The excitation current flows from CH1 through R_{SENSE} and protection resistors RP1 and RP4 (CH5 is internally grounded) while the thermistor differential measurement occurs at CH3 and CH4. The thermistor is assigned to CH4 and R_{SENSE} sharing is enabled in order to provide an internal ground connection.

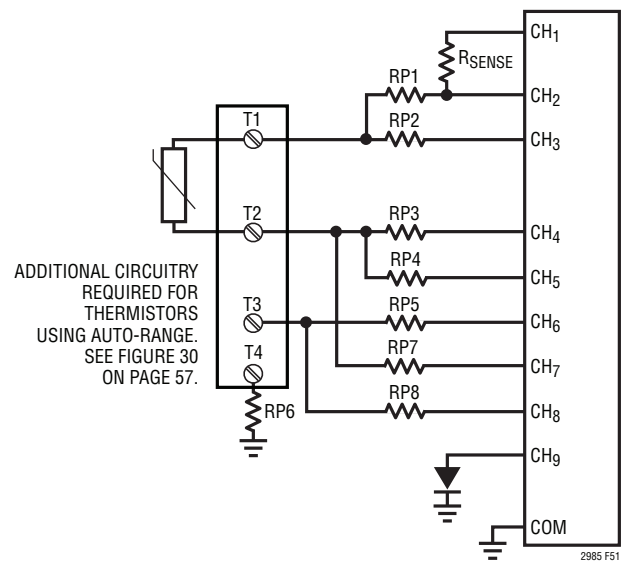

Figure 51. Protected Multi-Sensor Thermistor Connection

APPLICATIONS INFORMATION

Figure 52 shows the interface to a thermocouple using the LTM2985 multi-sensor circuit. In this case, the thermocouple ties directly to terminals T3 and T4 while terminals T1 and T2 can be left floating or tied to an RTD (Global Register G5 = 1) or thermistor (Global Register G6 = 1) for cold junction compensation. Alternatively, a diode (tied to CH9) can be used for cold junction compensation. The thermocouple is assigned to CH6 with single ended measurement mode.

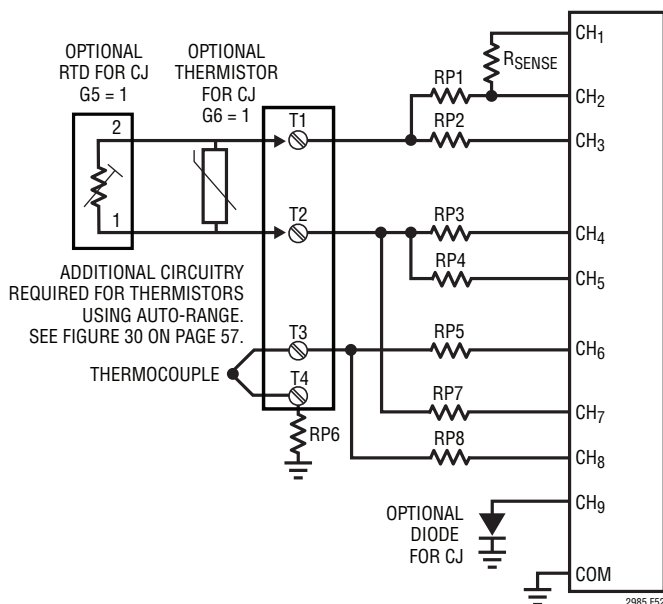

Figure 52. Protected Multi-Sensor Thermocouple Connection

ACTIVE ANALOG TEMPERATURE SENSORS

In addition to passive type temperature sensors, the LTM2985 also supports active analog temperature sensors (e.g., LTC2997). In this mode, the LTM2985 measures the voltage output from the analog temperature sensor and does a table lookup to convert the measured voltage to temperature. This sensor option is fully customizable and can be used for direct temperature measurement or cold junction compensation.

Analog Sensor Channel Assignment and Result Formats

For the active analog temperature sensor type = 31 (see Table 4 and Figure 53), the channel assignment word is 0xF800 0000 for differential measurements and 0xFC00 0000 for single-ended. When the LTM2985 is configured for the active analog temperature sensor type, it will take the measured voltage value from the ADC and perform a table lookup to produce a temperature result. The result format of the table lookup will be a 24-bit signed fixed-point temperature result along with the error status byte. The fixed-point format of the temperature is identical to all the other LTM2985 temperature sensor types. This format can be seen in Table 9A and Table 9B.

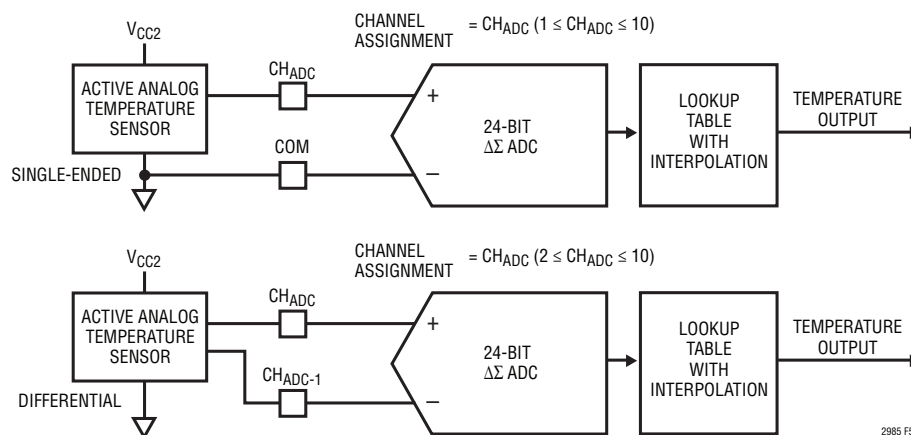

Figure 53. Active Analog Temperature Sensor Channel Assignment Conventions

APPLICATIONS INFORMATION

The error status byte is located in the upper byte of the data output word. Table 68 shows format of the error status byte for the analog sensor type. Bit D31 and D30 indicate a bad ADC reading. This can be a result of either a broken (open) sensor or an excessive noise event (ESD or static discharge into the sensor path). Either of these are a hard error and -999°C or $^{\circ}\text{F}$ is reported. In the case of an excessive noise event, the device should recover and the following conversions will be valid if the noise event was a random, infrequent event. Bits D27 and D26 indicate over or under temperature limits have been exceeded the table limits as described in Table 68. Bit D25 indicates the absolute voltage measured by the ADC is beyond its normal operating range.

Example: Differential Active Analog Temperature Sensor

In this example, a simplified temperature curve is implemented (see Figure 54). Points P1 to P9 represent the

normal operating range of the custom device. Voltage readings above point P9 result in a soft fault and the reported result is a linear extrapolation using a slope determined by points P8 and P9 (the final two table entries). Voltage readings below point P1 are also reported as soft faults. The reported result is the extrapolation between point P1 and P0, where P0 is typically the lowest possible sensor output voltage. Sensor output voltages below P0 (in mV) will report P0 output.

In order to program the LTM2985 with an active analog temperature sensor table, both the mV data and the Kelvin data are converted to 24-bit binary values (represented as two, 3-byte table entries, see Table 69). Since some analog sensors generate negative output voltages, the table mV values are 2's compliment. The sensor output voltage (units = mV) follows the convention shown in Table 71, where the first bit is the sign, the next 11 bits are the integer part and the remaining 12 bits are the fractional part.

Table 68. Active Analog Temperature Sensor Fault Data Byte

BIT	FAULT	ERROR TYPE	DESCRIPTION	OUTPUT RESULT
D31	Hard Fault	Hard	$V_{\text{ADC}} < -1.75 \cdot V_{\text{REF}}/2$ or $V_{\text{ADC}} > 1.75 \cdot V_{\text{REF}}/2$	-999
D30	Range Hard Fault	Hard	$V_{\text{ADC}} < -1.75 \cdot V_{\text{REF}}/2$ or $V_{\text{ADC}} > 1.75 \cdot V_{\text{REF}}/2$	-999
D29	Not Used	N/A	NA	NA
D28	Not Used	N/A	NA	NA
D27	Soft Above	Soft	$V_{\text{ADC}} >$ Last Table Point Voltage	Suspect Reading
D26	Soft Below	Soft	$V_{\text{ADC}} <$ Second Table Point (P1) Voltage	Suspect Reading
D25	Soft Range	Soft	$V_{\text{ADC}} < -1.125 \cdot V_{\text{REF}}/2$ or $V_{\text{ADC}} > 1.125 \cdot V_{\text{REF}}/2$	Suspect Reading
D24	Result Valid (Always 1)	NA	NA	NA

Active Analog Temperature Sensor Table Format

Table 69. Active Analog Temperature Sensor Table Format

ADDRESS	BYTE 0	BYTE 1	BYTE 2	BYTE 3	BYTE 4	BYTE 5
$0x250 + 6 \cdot \text{Start Address}$	Table Entry #1 (mV)			Table Entry #1 (Kelvin)		
$0x250 + 6 \cdot \text{Start Address} + 6$	Table Entry #2 (mV)			Table Entry #2 (Kelvin)		
$0x250 + 6 \cdot \text{Start Address} + 12$	Table Entry #3 (mV)			Table Entry #3 (Kelvin)		
.
.
.
Max Address = $0x3CA$	Table Entry #64 (mV)			Table Entry #64 (Kelvin)		

APPLICATIONS INFORMATION

The temperature values are input in Kelvin as unsigned fixed-point values, but the final temperatures reported by the LTM2985 are reported in °C or °F. The sensor temperature (Kelvin) follows the convention shown in Table 72, where the first 14 bits are the integer part and the remaining 10 bits are the fractional part. In this example, a custom analog sensor is tied to CH2 and is programmed with the channel assignment data shown in Table 73. In this

case the custom data begins at memory location 0x250 (starting address is 0). The starting address (offset from 0x250) is entered in the analog sensor data pointer field of the channel assignment data. The table data length –1 (9 in this example) is entered into the data length field of the analog temperature sensor channel assignment word. Refer to Table 70 for the location and format of the 10 six-byte table entries.

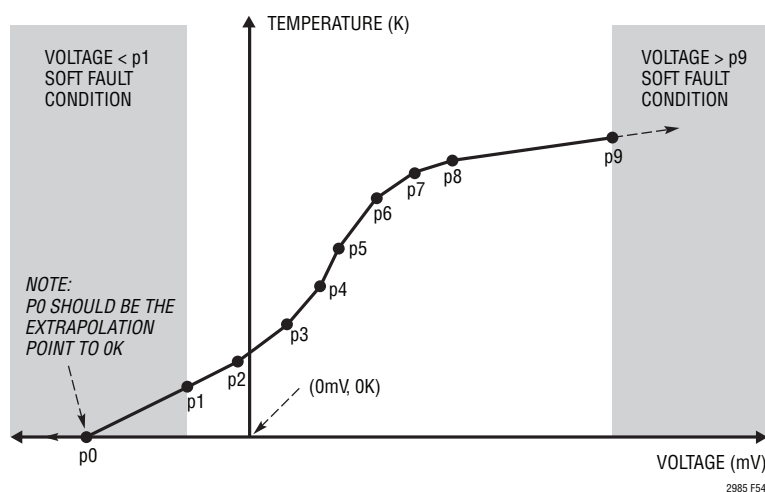

Figure 54. Active Analog Temperature Sensor Table Example

Table 70. Active Analog Temperature Sensor Example Table Data Memory Map

POINT	SENSOR OUTPUT VOLTAGE (mV)	TEMPERATURE KELVIN	START ADDRESS	STOP ADDRESS	BYTE 0	BYTE 1	BYTE 2	BYTE 3	BYTE 4	BYTE 5
p0	-50.22	0	0x250	0x255						
p1	-30.2	99.1	0x256	0x25B						
p2	-5.3	135.4	0x25C	0x261						
p3	20.33	220.3	0x262	0x267						
p4	40.2	361.2	0x268	0x26D	mV Data			Temperature Data		
p5	55.3	522.1	0x26E	0x273						
p6	88.3	720.3	0x274	0x279						
p7	132.2	811.2	0x27A	0x27F						
p8	188.7	922.5	0x280	0x285						
p9	460.4	1000	0x286	0x28B						

APPLICATIONS INFORMATION

DIRECT ADC MEASUREMENTS

In addition to measuring temperature sensors, the LTM2985 can perform direct ADC (i.e. voltage) measurements. Any channel may be configured to perform direct single-ended or differential measurements. Direct ADC channel assignments follow the general convention shown in Figure 55. The 32-bit channel assignment word is programmed into a memory location corresponding to the input channel.

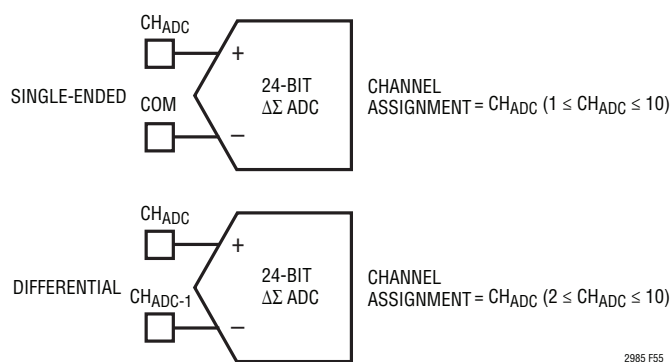

Figure 55. Direct ADC Channel Assignment Conventions

The Direct ADC mode is configurable to single-ended as well as differential inputs. The positive input channel ties to CH_{ADC} for both single-ended and differential modes. For single-ended measurements the ADC negative input is COM while for differential measurements it is CH_{ADC-1} . For single-ended measurements, COM can be driven with any voltage above $GND - 50mV$ and below $V_{CC2} - 0.3V$. The direct ADC results are available in memory at a location corresponding to the conversion channel.

There are two result mode options for direct ADC operation. The first mode is direct voltage output and the second is table-driven output. When configured for direct voltage output, the LTM2985 will return a 24-bit fixed-point voltage result along with the 8-bit fault status byte. When configured for table-lookup, the LTM2985 will perform a table lookup on the raw ADC voltage and return a 24-bit signed-integer table-lookup result along with the 8-bit fault status byte.

Figure 56 shows typical integral nonlinearity variation as a function of supply voltage and temperature for a differential input voltage ($\pm V_{REF}/2$) and $V_{REF}/2$ common mode input voltage.

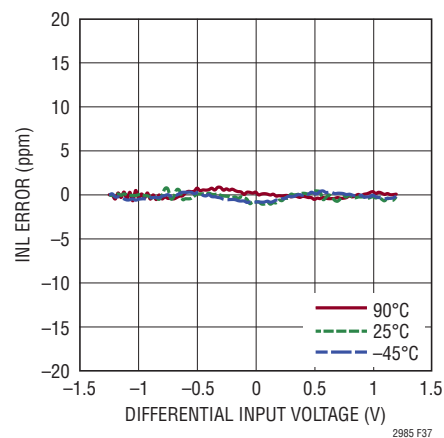

Figure 56. Integral Nonlinearity as a Function of Temperature at $V_{CC2} = 5.25V$

APPLICATIONS INFORMATION

Voltage Output Mode

For standard (non table mode) voltage output mode, the channel assignment word is 0xF000 0000 for differential readings and 0xF400 0000 for single-ended (see Table 75).

The data is represented as a 32-bit word (see Table 74) where the eight most significant bits are fault bits and the bottom 24 are the ADC reading in volts. For direct

ADC readings hard fault errors do not clamp the digital output. Readings beyond $\pm 1.125 \cdot V_{REF}/2$ exceed the normal accuracy range of the LTM2985 and flag a soft error; these results should be discarded. Readings beyond $\pm 1.75 \cdot V_{REF}/2$ exceed the usable range of the LTM2985; these result in a hard fault and should be discarded.

Table 74. Direct ADC Voltage Output Result Format

	START ADDRESS								START ADDRESS + 1								START ADDRESS + 2								START ADDRESS + 3 (END ADDRESS)							
	D31	D30	D29	D28	D27	D26	D25	D24	D23	D22	D21	D20	D19	D18	D17	D16	D15	D14	D13	D12	D11	D10	D9	D8	D7	D6	D5	D4	D3	D2	D1	D0
	Fault Data								SIGN MSB								LSB															
Volts	Sensor Hard Fault	Range Hard Fault	NA	NA	Soft Above	Soft Below	Soft Range	Valid Always 1																								
									$\pm 2V$	$1V$	$0.5V$	$0.25V$...																			
									Integer								Fraction															
$>V_{REF}$	1	1	0	0	1	0	1	1	CLAMPED to Factory Programmed Value of V_{REF}																							
$1.75 \cdot V_{REF}/2$	1	1	0	0	1	0	1	1	0	1	0	0	0	1	1	0	0	0	0	0	0	0	0	0	0	0	0	0	0	0	0	
$1.125 \cdot V_{REF}/2$	0	0	0	0	1	0	1	1	0	0	1	0	1	1	0	1	0	0	0	0	0	0	0	0	0	0	0	0	0	0	0	
$V_{REF}/2$	0	0	0	0	0	0	0	1	0	0	1	0	1	0	0	0	0	0	0	0	0	0	0	0	0	0	0	0	0	0	0	
$2^{-21}V$	0	0	0	0	0	0	0	1	0	0	0	0	0	0	0	0	0	0	0	0	0	0	0	0	0	0	0	0	0	0	0	
0	0	0	0	0	0	0	0	1	0	0	0	0	0	0	0	0	0	0	0	0	0	0	0	0	0	0	0	0	0	0	0	
$-2^{-21}V$	0	0	0	0	0	0	0	1	1	1	1	1	1	1	1	1	1	1	1	1	1	1	1	1	1	1	1	1	1	1	1	
$-V_{REF}/2$	0	0	0	0	0	0	0	1	1	1	0	1	0	1	1	1	1	1	1	1	1	1	1	1	1	1	1	1	1	1	1	
$-1.125 \cdot V_{REF}$	0	0	0	0	0	1	1	1	1	1	0	1	0	0	1	0	1	1	1	1	1	1	1	1	1	1	1	1	1	1	1	
$-1.75 \cdot V_{REF}$	1	1	0	0	0	1	1	1	1	0	1	1	1	0	0	1	1	1	1	1	1	1	1	1	1	1	1	1	1	1	1	
$< -V_{REF}$	1	1	0	0	0	1	1	1	CLAMPED to Factory Programmed Value of $-V_{REF}$																							

Example: Direct ADC with Differential Input

Table 75. Direct ADC Channel Assignment Data

CONFIGURATION FIELD	DESCRIPTION	# BITS	BINARY DATA	MEMORY ADDRESS 0x200	MEMORY ADDRESS 0x201	MEMORY ADDRESS 0x202	MEMORY ADDRESS 0x203																										
(1) Direct ADC	Directly Measure ADC	5	11110	1	1	1	1	0																									
(2) SE/Diff	Single-Ended or Differential	1	0					0																									
(3) TBL	Table Lookup	1	0					0																									
(4) Not Used	Set to 0	13	0000000000000						0	0	0	0	0	0	0	0	0	0	0	0	0	0	0	0	0	0	0	0	0	0	0		
(4) Direct ADC Table Data Pointer	Start Address = 0	6	000000																			0	0	0	0	0	0						
(5) Direct ADC Table Data Length-1	Data Length-1 = 0	6	000000																									0	0	0	0	0	0

APPLICATIONS INFORMATION

Table Lookup Mode

For table-driven output mode, the channel assignment word's 1st two bytes are 0xF200 for differential readings and 0xF600 for single-ended. The 12 least significant bits

contain length and pointer information for the custom table data. When the LTM2985 is configured for table-driven output data, it will take the voltage value from the ADC and perform a table lookup. The result format of the table lookup will be a 24-bit signed integer along with the error status byte.

Table 76. Direct ADC Table Lookup Result Format

START ADDRESS								START ADDRESS + 1								START ADDRESS + 2								START ADDRESS + 3 (END ADDRESS)							
D31	D30	D29	D28	D27	D26	D25	D24	D23	D22	D21	D20	D19	D18	D17	D16	D15	D14	D13	D12	D11	D10	D9	D8	D7	D6	D5	D4	D3	D2	D1	D0
Fault Data								SIGN								MSB								LSB							
Sensor Hard Fault	Range Hard Fault	NA	NA	Soft Above	Soft Below	Soft Range	Valid Always 1	Table Lookup Result – Signed Integer																							

Table 77. Direct ADC Table Lookup Fault Data Byte

BIT	FAULT	DESCRIPTION
D31	Sensor Hard Fault	$V_{ADC} < -1.75 \cdot V_{REF}/2$ or $V_{ADC} > 1.75 \cdot V_{REF}/2$
D30	Range Hard Fault	$V_{ADC} < -1.75 \cdot V_{REF}/2$ or $V_{ADC} > 1.75 \cdot V_{REF}/2$
D29	Not Used	NA
D28	Not Used	NA
D27	Soft Above	$V_{ADC} >$ Last Table Point Voltage
D26	Soft Below	$V_{ADC} <$ Second Table Point (P1) Voltage
D25	Soft Range	$V_{ADC} < -1.125 \cdot V_{REF}/2$ or $V_{ADC} > 1.125 \cdot V_{REF}/2$
D24	Result Valid (Always 1)	NA

Table 78. Direct ADC Table Format

ADDRESS	BYTE 0	BYTE 1	BYTE 2	BYTE 3	BYTE 4	BYTE 5
$0x250 + 6 \cdot \text{Start Address}$	Table Entry #1 (mV)			Table Entry #1 (Integer Value)		
$0x250 + 6 \cdot \text{Start Address} + 6$	Table Entry #2 (mV)			Table Entry #2 (Integer Value)		
$0x250 + 6 \cdot \text{Start Address} + 12$	Table Entry #3 (mV)			Table Entry #3 (Integer Value)		
•	•			•		
•	•			•		
•	•			•		
Max Address = 0x3CA	Table Entry #64 (mV)			Table Entry #64 (Integer Value)		

APPLICATIONS INFORMATION

Example: Direct ADC with Differential Input and Table Lookup

In this example, a simplified custom curve is implemented (see Figure 57). Points P1 to P9 represent the normal operating range of the custom device. Voltage readings above point P9 result in a soft fault and the reported result is a linear extrapolation using a slope determined by points P8 and P9 (the final two table entries). Voltage readings below point P1 are also reported as soft faults. The reported result is the extrapolation between point P1 and P0, where P0 is typically the lowest possible sensor output voltage. Sensor output voltages below P0 (in mV) will report P0 output.

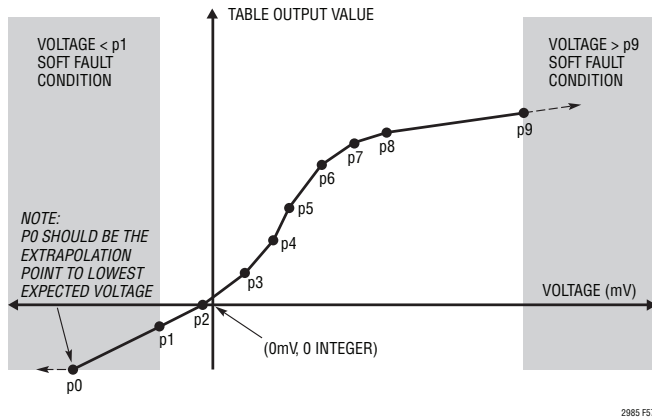

Figure 57. Direct ADC Table Example

In order to program the LTM2985 with the custom ADC table, both the mV data and the result data are converted to 24-bit binary values (represented as two 3-byte table entries). To accommodate sensors with bipolar output voltages, the mV values input to the LTM2985 are 2’s compliment. The sensor output voltage (units = mV) follows the convention shown in Table 80, where the first bit is the sign, the next 11 bits are the integer part and the remaining 12 bits are the fractional part.

The result-side of table entries are input as signed 24-bit integers, the final result reported by the LTM2985 is also a 24-bit integer. The result format follows the convention shown in Table 81, where the first bit is the sign bit and the remaining 23 bits are the integer magnitude. In this example, a custom differential sensor is tied to CH2 with the channel assignment data shown in Table 82. In this case the custom data begins at memory location 0x250 (starting address is 0). The starting address (offset from 0x250) is entered in the data pointer field of the channel assignment data. The table data length-1 (9 in this example) is entered into the data length field of the sensor channel assignment word. Refer to Table 79 for the location and format of the 10 six-byte table entries.

Table 79. Direct ADC Table Example Data Memory Map

POINT	SENSOR OUTPUT VOLTAGE (mV)	INTEGER OUTPUT DATA	START ADDRESS	STOP ADDRESS	BYTE 0	BYTE 1	BYTE 2	BYTE 3	BYTE 4	BYTE 5
p0	-50.22	-100	0x250	0x255						
p1	-30.2	-50	0x256	0x25B						
p2	-5.3	0	0x25C	0x261						
p3	20.33	2203	0x262	0x267						
p4	40.2	3612	0x268	0x26D	mV Data			Integer Output Data		
p5	55.3	5221	0x26E	0x273						
p6	88.3	7203	0x274	0x279						
p7	132.2	8112	0x27A	0x27F						
p8	188.7	9225	0x280	0x285						
p9	460.4	10000	0x286	0x28B						

SUPPLEMENTAL INFORMATION

2- AND 3-CYCLE CONVERSION MODES

The LTM2985 performs multiple internal conversions in order to determine the sensor temperature. Normally, two internal conversion cycles are required for each temperature result providing a maximum output time of 167.2ms. The LTM2985 uses these two cycles to automatically remove offset/offset drift errors, reduce 1/f noise, auto-calibrate matched internal current sources and provide simultaneous 50/60Hz noise rejection.

In addition to performing two conversion cycles per result, the LTM2985 also offers several unique features by utilizing a 3rd conversion cycle. In this case, the maximum output time is 251ms and all the benefits of the 2-cycle modes are present (see Table 83).

One feature utilizing the three conversion cycle mode is the internal open circuit detect mode. Typically, thermocouple open circuit detection is performed by adding a high resistance pull-up between the thermocouple and V_{CC2} . This method can be used with the LTM2985 while operating in the two conversion cycle mode (OC=0). This external pull-up can interact with the input protection circuitry and lead to temperature measurement errors and increased noise. These problems are eliminated by selecting the internal open circuit detection mode (OC=1). In this case, a current is pulsed for 8ms and allowed to settle during one conversion cycle. This is followed by the normal two conversion cycle measurement of the thermocouple. If the thermocouple is broken, the current pulse will result in an open circuit fault.

A second feature taking advantage of the 3rd conversion cycle is thermistor excitation current auto ranging. Since a thermistor's resistance varies many orders of magnitude, the performance in the low resistance regions are compromised by the small currents required by the high resistance regions of operation. The auto ranging mode applies a test current during the first conversion cycle in order to determine the optimum current for the resistance state of the thermistor. It then uses that current to perform the thermistor measurement using the normal 2-cycle measurement. If a 3-cycle thermistor measurement is used as the cold junction sensor for a 2-cycle thermocouple

measurement, the thermocouple conversion result is ready after three cycles.

A third feature requiring a 3rd conversion cycle is the three current diode measurement. In this mode, three ratioed currents are applied to the external diode in order to cancel parasitic lead resistance effects. This is useful in applications where the diode is remotely located and significant, unknown parasitic lead resistance requires cancellation. If a 3-cycle diode or thermistor measurement is used as the cold junction sensor for a 2-cycle thermocouple measurement, the thermocouple conversion result is ready after three cycles.

Table 83. 2- and 3-Cycles Conversion Modes

TYPE OF SENSOR	CONFIGURATION	NUMBER OF CONVERSION CYCLES	MAXIMUM OUTPUT TIME
Thermocouple	OC = 0	2	167.2ms
RTD	All	2	167.2ms
Thermistor	Non-Autorange Current	2	167.2ms
Diode	Two Readings	2	167.2ms
Thermocouple	OC = 1	3	251ms
Thermocouple	OC = 0, 3-Cycle Cold Junction	3	251ms
Thermistor	Autorange Current	3	251ms
Diode	Three Readings	3	251ms

RUNNING CONVERSIONS CONSECUTIVELY ON MULTIPLE CHANNELS

Generally, during the Initiate Conversion state, a conversion measurement is started on a single input channel determined by the channel number (bits B[4:0] = 00001 to 01010) written into memory location 0x000. Multiple consecutive conversions can be initiated by writing bits B[4:0]=00000 into memory location 0. Conversions will be initiated on each channel selected in the mask register (see Table 84).

For example, using the mask data shown in Table 85, after 1000000 is written into memory location 0, conversions are initiated consecutively on CH10, CH8, CH6 and CH1.

SUPPLEMENTAL INFORMATION

Once the conversions begin, the INT pin goes LOW and remains LOW until all conversions are complete. If the mask register is set for a channel that has no assignment data, that conversion step is skipped. All the results are stored in the conversion result memory locations and can be read at the conclusion of the measurement cycle.

ENTERING/EXITING SLEEP MODE

The LTM2985 can be placed into sleep mode by writing 0x97 to memory location 0x000. On the rising edge of \overline{CS} following the memory write (see Figure 2) the device enters the low power sleep state. It remains in this state until \overline{CS} is brought low. Once one of these two signals is asserted, the LTM2985 begins its start-up cycle as described in State 1: Start-Up section of this data sheet.

MUX CONFIGURATION DELAY

The LTM2985 performs 2 or 3 internal conversion cycles per temperature result. Each conversion cycle is performed with different excitation and input multiplexer configurations. Prior to each conversion, these excitation circuits and input switch configurations are changed and an

internal 1ms (typical) delay ensures settling prior to the conversion cycle in most cases.

If excessive RC time constants are present in external sensor circuits (large bypass capacitors used for thermistors or RTDs) it is possible to increase the settling time between current source excitation and MUX switching. The extra delay is determined by the value written into the MUX configuration delay register (memory location 0x0FF). The value written into this memory location is multiplied by 100 μ s; therefore, the maximum extra MUX delay is 25.5ms (i.e. 0x0FF = 255 • 100 μ s).

REFERENCE CONSIDERATIONS

The mechanical stress of soldering the LTM2985 to a PC board can cause the output voltage reference to shift and temperature coefficient to change. These two changes are not correlated. For example, the voltage may shift but the temperature coefficient may not. To reduce the effects of stress-related shifts, mount the reference near the short edge of the PC board or in a corner.

Table 84. Multiple Conversion Mask Register

MEMORY LOCATION	B7	B6	B5	B4	B3	B2	B1	B0
0x0F4		Reserved						
0x0F5								
0x0F6							CH10	CH9
0x0F7	CH8	CH7	CH6	CH5	CH4	CH3	CH2	CH1

Table 85. Example Mask Register Select CH10, CH8, CH6 and CH1

MEMORY LOCATION	B7	B6	B5	B4	B3	B2	B1	B0
0x0F4		Reserved						
0x0F5								
0x0F6							1	0
0x0F7	1	0	1	0	0	0	0	1

CUSTOM THERMOCOUPLES

the reported temperature is a linear extrapolation using a slope determined by points P8 and P9 (the final two table entries in Table 87). Voltage readings below point P1 are also reported as soft faults. The temperature reported is the extrapolation between point P1 and P0, where P0 is typically the sensor output voltage at 0 Kelvin. If P0 is above 0 Kelvin, then all sensor output voltages below P0 (in mV) will report 0 Kelvin. Sensor readings below P1 are reported as soft faults.

In order to program the LTM2985 with the custom thermocouple table, both the mV data and the Kelvin data are converted to 24-bit binary values (represented as two 3-byte table entries). Since most thermocouples generate negative output voltages, the mV values input to the LTM2985 are 2's complement. The sensor output voltage (units=mV), follows the convention shown in Table 88, where the first bit is the sign, the next nine are the integer part and the remaining 14 bits are the fractional part.

Table 87. Thermocouple Example mV vs Kelvin (K) Data Memory Map

POINT	SENSOR OUTPUT VOLTAGE (mV)	TEMPERATURE KELVIN	START ADDRESS	STOP ADDRESS	BYTE 0	BYTE 1	BYTE 2	BYTE 3	BYTE 4	BYTE 5
p0	-50.22	0	0x250	0x255						
p1	-30.2	99.1	0x256	0x25B						
p2	-5.3	135.4	0x25C	0x261						
p3	0	273.15	0x262	0x267						
p4	40.2	361.2	0x268	0x26D	mV Data			Temperature Data		
p5	55.3	522.1	0x26E	0x273	(see Table 88)			(see Table 89)		
p6	88.3	720.3	0x274	0x279						
p7	132.2	811.2	0x27A	0x27F						
p8	188.7	922.5	0x280	0x285						
p9	460.4	1000	0x286	0x28B						

Table 88. Example Thermocouple Output Voltage Values (mV)

mV	BYTE 0								BYTE 1								BYTE 2							
	B23	B22	B21	B20	B19	B18	B17	B16	B15	B14	B13	B12	B11	B10	B9	B8	B7	B6	B5	B4	B3	B2	B1	B0
	Sign	2 ⁸	2 ⁷	2 ⁶	2 ⁵	2 ⁴	2 ³	2 ²	2 ¹	2 ⁰	2 ⁻¹	2 ⁻²	2 ⁻³	2 ⁻⁴	2 ⁻⁵	2 ⁻⁶	2 ⁻⁷	2 ⁻⁸	2 ⁻⁹	2 ⁻¹⁰	2 ⁻¹¹	2 ⁻¹²	2 ⁻¹³	2 ⁻¹⁴
-50.22	1	1	1	1	0	0	1	1	0	1	1	1	0	0	0	1	1	1	1	0	1	1	0	0
-30.2	1	1	1	1	1	0	0	0	0	1	1	1	0	0	1	1	0	0	1	1	0	1	0	0
-5.3	1	1	1	1	1	1	1	0	1	0	1	0	1	1	0	0	1	1	0	0	1	1	0	1
0	0	0	0	0	0	0	0	0	0	0	0	0	0	0	0	0	0	0	0	0	0	0	0	0
40.2	0	0	0	0	1	0	1	0	0	0	0	0	1	1	0	0	1	1	0	0	1	1	0	0
55.3	0	0	0	0	1	1	0	1	1	1	0	1	0	0	1	1	0	0	1	1	0	0	1	1
88.3	0	0	0	1	0	1	1	0	0	0	0	1	0	0	1	1	0	0	1	1	0	0	1	1
132.2	0	0	1	0	0	0	0	1	0	0	0	0	1	1	0	0	1	1	0	0	1	1	0	0
188.7	0	0	1	0	1	1	1	1	0	0	1	0	1	1	0	0	1	1	0	0	1	1	0	0
460.4	0	1	1	1	0	0	1	1	0	0	0	1	1	0	0	1	1	0	0	1	1	0	0	1

CUSTOM THERMOCOUPLES

In order to simplify the temperature field, temperature values are input in Kelvin as an unsigned value, but the final temperatures reported by the LTM2985 are reported in °C or °F (see Table 9A and Table 9B). The sensor temperature (Kelvin), follows the convention shown in Table 89, where the first 14 bits are the integer part and the remaining 10 bits are the fractional part.

In this example, a custom thermocouple tied to CH1, with a cold junction sensor on CH2, is programmed with the chan-

nel assignment data shown in Table 90 (refer to Figure 9 for similar format). In this case the custom data begins at memory location 0x250 (starting address is 0). The starting address (offset from 0x250) is entered in the custom thermocouple data pointer field of the channel assignment data. The table data length-1 (9 in this example) is entered into the custom thermocouple data length field of the thermocouple channel assignment word. Refer to Table 87 where the number of six byte entries is 10.

Table 89. Example Thermocouple Temperature Values

	BYTE 3								BYTE 4								BYTE 5							
	B23	B22	B21	B20	B19	B18	B17	B16	B15	B14	B13	B12	B11	B10	B9	B8	B7	B6	B5	B4	B3	B2	B1	B0
Temperature	2 ¹³	2 ¹²	2 ¹¹	2 ¹⁰	2 ⁹	2 ⁸	2 ⁷	2 ⁶	2 ⁵	2 ⁴	2 ³	2 ²	2 ¹	2 ⁰	2 ⁻¹	2 ⁻²	2 ⁻³	2 ⁻⁴	2 ⁻⁵	2 ⁻⁶	2 ⁻⁷	2 ⁻⁸	2 ⁻⁹	2 ⁻¹⁰
0	0	0	0	0	0	0	0	0	0	0	0	0	0	0	0	0	0	0	0	0	0	0	0	0
99.1	0	0	0	0	0	0	0	1	1	0	0	0	1	1	0	0	0	1	1	0	0	1	1	0
135.4	0	0	0	0	0	0	1	0	0	0	0	1	1	1	0	1	1	0	0	1	1	0	0	1
273.15	0	0	0	0	0	1	0	0	0	1	0	0	0	1	0	0	1	0	0	1	1	0	0	1
361.2	0	0	0	0	0	1	0	1	1	0	1	0	0	1	0	0	1	1	0	0	1	1	0	0
522.1	0	0	0	0	1	0	0	0	0	0	1	0	1	0	0	0	0	1	1	0	0	1	1	0
720.3	0	0	0	0	1	0	1	1	0	1	0	0	0	0	1	0	0	1	1	0	0	1	1	1
811.2	0	0	0	0	1	1	0	0	1	0	1	0	1	1	0	0	1	1	0	0	1	1	0	0
922.5	0	0	0	0	1	1	1	0	0	1	1	0	1	0	1	0	0	0	0	0	0	0	0	0
1000	0	0	0	0	1	1	1	1	1	0	1	0	0	0	0	0	0	0	0	0	0	0	0	0

Table 90. Custom Thermocouple Channel Assignment Data

CONFIGURATION FIELD	DESCRIPTION	# BITS	BINARY DATA	MEMORY ADDRESS 0x200	MEMORY ADDRESS 0x201	MEMORY ADDRESS 0x202	MEMORY ADDRESS 0x203																				
(1) Thermocouple Type	Type Custom	5	01001	0	1	0	0	1																			
(2) Cold Junction Channel Pointer	CH ₂	5	00010						0	0	0	1	0														
(3) Sensor Configuration	Single-Ended, 10µA Open Circuit	4	1100											1	1	0	0										
Not Used	Set These Bits to 0	6	000000														0	0	0	0	0	0					
(4) Custom Thermocouple Data Pointer	Start Address = 0 (Start at 0x250)	6	000000																0	0	0	0	0	0			
(5) Custom Thermocouple Data Length-1	Data Length -1 = 9 (10 Paired Entries)	6	001001																			0	0	1	0	0	1

CUSTOM RTDS

In addition to digitizing standard RTDs, the LTM2985 can also digitize custom RTDs (RTD type=0b10010, see Table 30). Custom sensor data (minimum of three, maximum of 64 pairs) reside sequentially in memory and are arranged in blocks of six bytes of monotonically increasing tabular data Ω vs temperature (see Table 91).

Table 91. Custom RTD/Thermistor Tabular Data Format

ADDRESS	BYTE 0	BYTE 1	BYTE 2	BYTE 3	BYTE 4	BYTE 5
$0x250 + 6 \cdot \text{Start Address}$	Table Entry #1 (Ω)			Table Entry #1 (Kelvin)		
$0x250 + 6 \cdot \text{Start Address} + 6$	Table Entry #2 (Ω)			Table Entry #2 (Kelvin)		
$0x250 + 6 \cdot \text{Start Address} + 12$	Table Entry #3 (Ω)			Table Entry #3 (Kelvin)		
.
.
.
Max Address = $0x3CA$	Table Entry #64 (Ω)			Table Entry #64 (Kelvin)		

Custom RTD Example

In this example, a simplified RTD curve is implemented (see Figure 59). Points P1 to P9 represent the normal operating range of the custom RTD. Resistance readings above point P9 result in a soft fault and the reported temperature is a linear extrapolation using a slope determined by points P8 and P9 (the final two table entries). Resistance readings below point P1 are also reported as soft faults. The temperature reported is the extrapolation between point P1 and P0, where P0 is the sensor output temperature at 0Ω (This point should be 0Ω for proper interpolation below point P1).

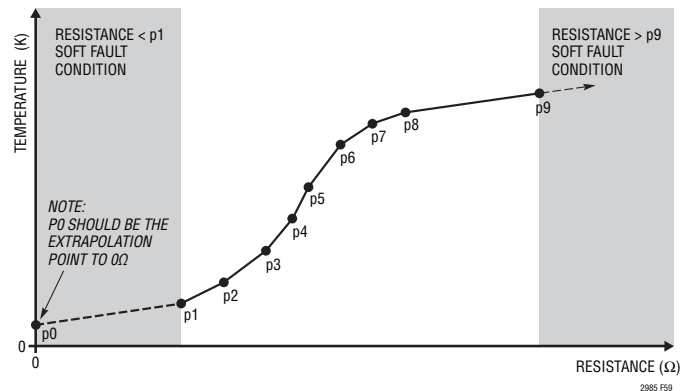

Figure 59. Custom RTD Example (Ω vs Kelvin)

CUSTOM RTDS

Custom RTD table data is formatted in Ω (sensor output resistance) vs Kelvin (see Table 92). Each table entry pair spans six bytes. The first set of data can begin at any memory location greater than or equal to 0x250 and end at or below 0x3CF.

In order to program the LTM2985 with the custom RTD table, both the resistance data and the Kelvin data are converted to 24-bit binary values. The sensor output

resistance (units= Ω) follows the convention shown in Table 93, where the first 13 bits are the integer part and the remaining 11 bits are the fractional part.

In order to simplify the temperature field, temperature values are input in Kelvin as an unsigned value, but the final temperatures reported by the LTM2985 are reported in $^{\circ}\text{C}$ or $^{\circ}\text{F}$. The sensor temperature (Kelvin) follows the

Table 92. RTD Example Resistance vs Kelvin Data Memory Map

POINT	SENSOR OUTPUT RESISTANCE (Ω)	TEMPERATURE (K)	START ADDRESS	STOP ADDRESS	BYTE 1	BYTE 2	BYTE 3	BYTE 1	BYTE 2	BYTE 3
P0	0	112.3	0x28C	0x291						
P1	80	200.56	0x292	0x297						
P2	150	273.16	0x298	0x29D						
P3	257.36	377.25	0x29E	0x2A3						
P4	339.22	489.66	0x2A4	0x2A9	Resistance Data			Temperature Data		
P5	388.26	595.22	0x2AA	0x2AF						
P6	512.99	697.87	0x2B0	0x2B5						
P7	662.3	765.14	0x2B6	0x2BB						
P8	743.5	801.22	0x2BC	0x2C1						
P9	2001.89	900.5	0x2C2	0x2C7						

Table 93. Example RTD Resistance Values

	BYTE 1								BYTE 2								BYTE 3							
	B23	B22	B21	B20	B19	B18	B17	B16	B15	B14	B13	B12	B11	B10	B9	B8	B7	B6	B5	B4	B3	B2	B1	B0
Resistance	2 ¹²	2 ¹¹	2 ¹⁰	2 ⁹	2 ⁸	2 ⁷	2 ⁶	2 ⁵	2 ⁴	2 ³	2 ²	2 ¹	2 ⁰	2 ⁻¹	2 ⁻²	2 ⁻³	2 ⁻⁴	2 ⁻⁵	2 ⁻⁶	2 ⁻⁷	2 ⁻⁸	2 ⁻⁹	2 ⁻¹⁰	2 ⁻¹¹
0	0	0	0	0	0	0	0	0	0	0	0	0	0	0	0	0	0	0	0	0	0	0	0	0
80	0	0	0	0	0	0	1	0	1	0	0	0	0	0	0	0	0	0	0	0	0	0	0	0
150	0	0	0	0	0	1	0	0	1	0	1	1	0	0	0	0	0	0	0	0	0	0	0	0
257.36	0	0	0	0	1	0	0	0	0	0	0	0	1	0	1	0	1	1	1	0	0	0	0	1
339.22	0	0	0	0	1	0	1	0	1	0	0	1	1	0	0	1	1	1	0	0	0	0	1	0
388.26	0	0	0	0	1	1	0	0	0	0	1	0	0	0	1	0	0	0	0	1	0	1	0	0
512.99	0	0	0	1	0	0	0	0	0	0	0	0	0	1	1	1	1	1	1	0	1	0	1	1
662.3	0	0	0	1	0	1	0	0	1	0	1	1	0	0	1	0	0	1	1	0	0	1	1	0
743.5	0	0	0	1	0	1	1	1	0	0	1	1	1	1	0	0	0	0	0	0	0	0	0	0
2001.89	0	0	1	1	1	1	1	0	1	0	0	0	1	1	1	1	0	0	0	1	1	1	1	0

CUSTOM RTDS

convention shown in Table 94, where the first 14 bits are the integer part and the remaining 10 bits are the fractional part.

In this example, a custom RTD tied to CH3/CH4, with a sense resistor on CH1/CH2, is programmed with the channel assignment data shown in Table 95 (refer to Figure 18 for a similar format). In this case, the custom data begins

at memory location 0x28C (starting address is 10). The starting address (offset from 0x250) is entered in the custom RTD data pointer field of the channel assignment data. The table data length –1 (9 in this case) is entered into the custom RTD data length field of the channel assignment word. Refer to Table 91 where the total number of paired entries is 10.

Table 94. Example RTD Temperature Values

	BYTE 1							BYTE 2							BYTE 3									
	B23	B22	B21	B20	B19	B18	B17	B16	B15	B14	B13	B12	B11	B10	B9	B8	B7	B6	B5	B4	B3	B2	B1	B0
Temperature	2 ¹³	2 ¹²	2 ¹¹	2 ¹⁰	2 ⁹	2 ⁸	2 ⁷	2 ⁶	2 ⁵	2 ⁴	2 ³	2 ²	2 ¹	2 ⁰	2 ⁻¹	2 ⁻²	2 ⁻³	2 ⁻⁴	2 ⁻⁵	2 ⁻⁶	2 ⁻⁷	2 ⁻⁸	2 ⁻⁹	2 ⁻¹⁰
112.3	0	0	0	0	0	0	0	1	1	1	0	0	0	0	1	0	0	1	1	0	0	1	1	
200.56	0	0	0	0	0	0	1	1	0	0	1	0	0	0	1	0	0	0	1	1	1	1	0	1
273.16	0	0	0	0	0	0	1	0	0	1	0	0	0	1	0	0	1	0	1	0	0	0	1	1
377.25	0	0	0	0	0	0	1	1	1	1	1	0	0	1	0	1	0	0	0	0	0	0	0	0
489.66	0	0	0	0	0	0	0	1	1	0	1	0	0	1	1	0	1	0	1	0	0	0	1	1
595.22	0	0	0	0	1	0	0	1	0	1	0	0	1	1	0	0	1	1	1	0	0	0	0	1
697.87	0	0	0	0	1	0	1	0	1	1	1	0	0	1	1	1	0	1	1	1	1	0	1	0
765.14	0	0	0	0	1	1	0	1	1	1	1	1	0	1	0	0	1	0	0	0	1	1	1	1
801.22	0	0	0	0	1	0	1	0	1	0	0	0	0	1	0	0	1	1	1	0	0	0	0	1
900.5	0	0	0	0	1	1	1	0	0	0	0	1	0	0	1	0	0	0	0	0	0	0	0	0

Table 95. Custom RTD Channel Assignment Data

CONFIGURATION FIELD	DESCRIPTION	# BITS	BINARY DATA	MEMORY ADDRESS 0x20C	MEMORY ADDRESS 0x20D	MEMORY ADDRESS 0x20E	MEMORY ADDRESS 0x20F																	
(1) RTD Type	Custom	5	10010	1	0	0	1	0																
(2) Sense Resistor Channel Pointer	CH ₂	5	00010						0	0	0	1	0											
(3) Sensor Configuration	4-Wire, No Rotate, No Share	4	1000											1	0	0	0							
(4) Excitation Current	25μA	4	0011															0	0	1	1			
(5) Curve	Not Used for Custom	2	00																					
(6) Custom RTD Data Pointer	Start Address = 10	6	001010																					
(7) Custom RTD Data Length-1	Data Length –1 = 9 10 Paired Entries	6	001001																					

CUSTOM THERMISTORS

In addition to digitizing standard thermistors, the LTM2985 can also digitize custom thermistors (thermistor type=0b11011, see Table 55). Custom sensor data (minimum of three, maximum of 64 pairs) reside sequentially in memory and are arranged in blocks of six bytes of monotonically increasing tabular data Ω vs temperature (see Table 91).

Custom Thermistor Table Example

In this example, a simplified thermistor NTC (negative temperature coefficient) curve is implemented (see Figure 60). Points P1 to P9 represent the normal operating range of the custom thermistor. Resistance readings above point

P9 result in a soft fault and the reported temperature is a linear extrapolation using a slope determined by points P8 and P9 (the final two table entries). Resistance readings below point P1 are also reported as soft faults. The temperature reported is the extrapolation between point P1 and P0, where P0 is the sensor output temperature at 0Ω (This point must be 0Ω for proper interpolation below point P1).

In addition to NTC type thermistors, it is also possible to implement PTC (positive temperature coefficient) type thermistors (see Figure 61). In both cases, table entries start at the minimum resistance and end at the maximum resistance value.

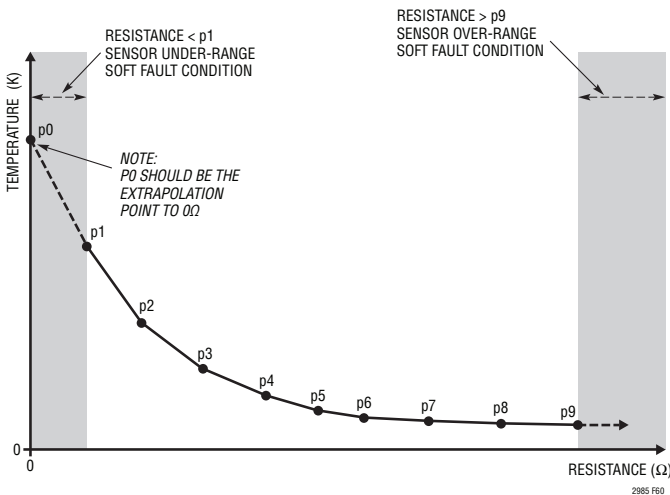

Figure 60. Custom NTC Thermistor Example (Ω vs Kelvin)

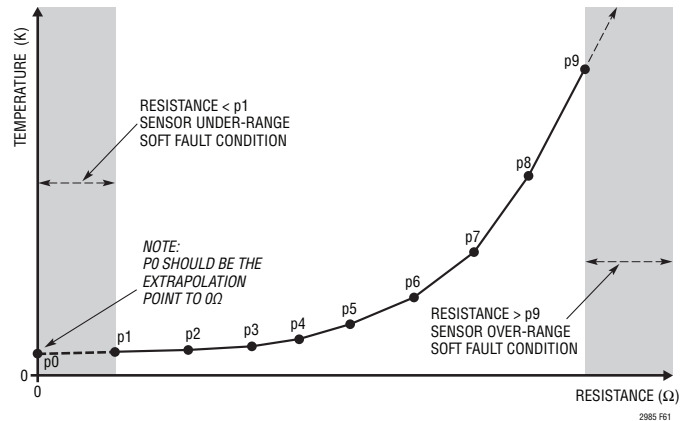

Figure 61. Custom PTC Thermistor Example (Ω vs Kelvin)

CUSTOM THERMISTORS

Custom thermistor table data is formatted in Ω (sensor output resistance) vs Kelvin (see Table 96). Each table entry pair spans six bytes. The first set of data can begin at any memory location greater than or equal to 0x250 and end below 0x3CF.

In order to program the LTM2985 with the custom thermistor table, both the resistance data and the Kelvin data are converted to 24-bit binary values. The sensor output resistance (units = Ω) follows the convention shown in

Table 97, where the first 20 bits are the integer part and the remaining four bits are the fractional part.

In order to simplify the temperature field, temperature values are input in Kelvin as an unsigned value, but the final temperatures reported by the LTM2985 are reported in $^{\circ}\text{C}$ or $^{\circ}\text{F}$. The sensor temperature (Kelvin) follows the convention shown in Table 98, where the first 14 bits are the integer part and the remaining 10 bits are the fractional part.

Table 96. NTC Thermistor Example Resistance vs Kelvin Data Memory Map

POINT	SENSOR OUTPUT RESISTANCE(Ω)	TEMPERATURE (K)	START ADDRESS	STOP ADDRESS	BYTE 1	BYTE 2	BYTE 3	BYTE 1	BYTE 2	BYTE 3
P0	0	457.5	0x2C8	0x2CD						
P1	80	400.2	0x2CE	0x2D3						
P2	184	372.3	0x2D4	0x2D9						
P3	423.2	320.1	0x2DA	0x2DF						
P4	973.36	290.55	0x2E0	0x2E5	Resistance Data			Temperature Data		
P5	2238.728	249.32	0x2E6	0x2EB						
P6	5149.0744	240.3	0x2EC	0x2F1						
P7	26775.18688	230	0x2F2	0x2F7						
P8	139230.9718	215.3	0x2F8	0x2FD						
P9	724001.0532	200	0x2FE	0x303						

Table 97. Example Thermistor Resistance Values

	BYTE 1								BYTE 2								BYTE 3							
	B23	B22	B21	B20	B19	B18	B17	B16	B15	B14	B13	B12	B11	B10	B9	B8	B7	B6	B5	B4	B3	B2	B1	B0
Resistance	2^{19}	2^{18}	2^{17}	2^{16}	2^{15}	2^{14}	2^{13}	2^{12}	2^{11}	2^{10}	2^9	2^8	2^7	2^6	2^5	2^4	2^3	2^2	2^1	2^0	2^{-1}	2^{-2}	2^{-3}	2^{-4}
0	0	0	0	0	0	0	0	0	0	0	0	0	0	0	0	0	0	0	0	0	0	0	0	0
80	0	0	0	0	0	0	0	0	0	0	0	0	0	1	0	1	0	0	0	0	0	0	0	0
184	0	0	0	0	0	0	0	0	0	0	0	1	0	1	1	1	0	0	0	0	0	0	0	0
423.2	0	0	0	0	0	0	0	0	0	0	1	1	0	1	0	0	1	1	1	0	0	1	1	1
973.36	0	0	0	0	0	0	0	0	0	1	1	1	1	0	0	1	1	0	1	0	1	0	1	1
2238.728	0	0	0	0	0	0	0	0	1	0	0	0	1	0	1	1	1	1	0	1	0	1	1	1
5149.074	0	0	0	0	0	0	0	1	0	1	0	0	0	0	1	1	1	0	1	0	0	0	0	1
26775.19	0	0	0	0	0	1	1	0	1	0	0	0	1	0	0	1	0	1	1	1	0	0	1	1
139231	0	0	1	0	0	0	0	1	1	1	1	1	1	0	1	1	1	1	1	0	0	0	0	0
724001.1	1	0	1	1	0	0	0	0	1	1	0	0	0	0	1	0	0	0	0	1	0	0	0	1

TYPICAL APPLICATION

Universal Inputs Allow Common Hardware Sharing for Thermocouples, Diodes, Thermistors, 3-Wire RTDs and 4-Wire RTDs

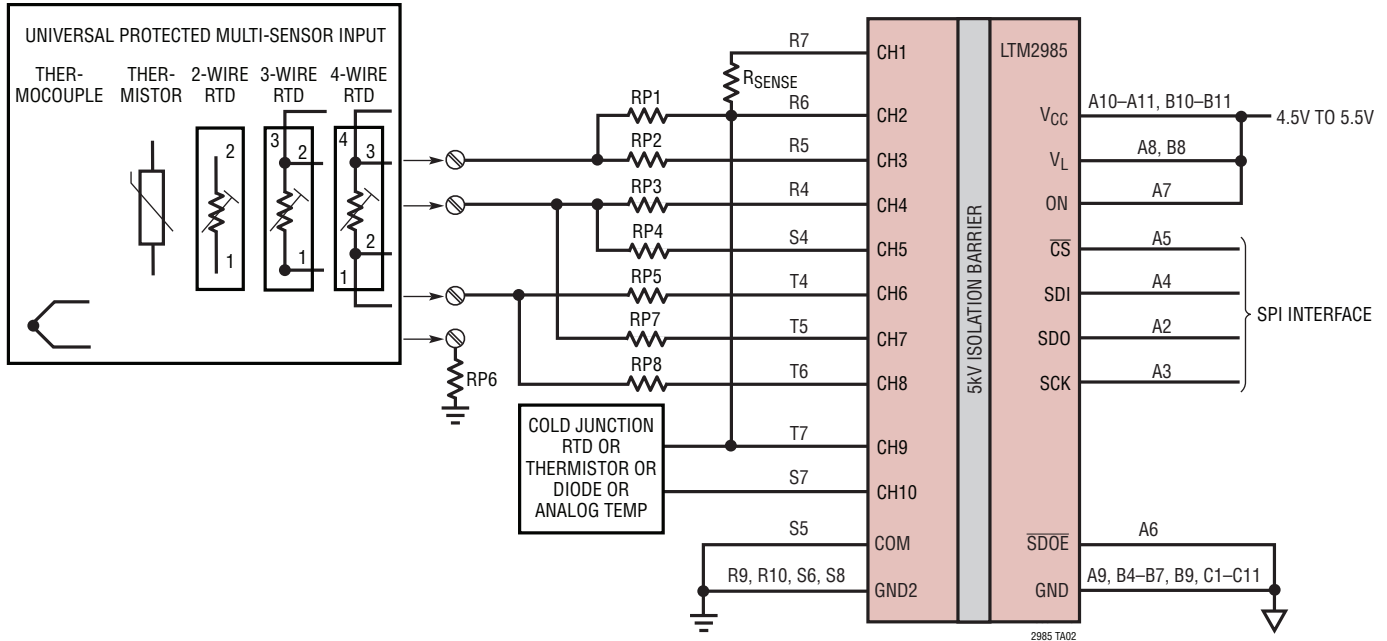

RELATED PARTS

PART NUMBER	DESCRIPTION	COMMENTS
LTC2986	Multi-Sensor High Accuracy Digital Temperature Measurement System without EEPROM	Non-Isolated 10-channel. Software Compatible with LTM2985
LTC2986-1	Multi-Sensor High Accuracy Digital Temperature Measurement System with EEPROM	Non-Isolated 10-channel. Software Compatible with LTM2985
LTC2983	Multi-Sensor High Accuracy Digital Temperature Measurement System	Pin/Software Compatible 20-Channel Version of LTC2986
LTC2984	Multi-Sensor High Accuracy Digital Temperature Measurement System with EEPROM	Pin/Software Compatible 20-Channel Version of LTC2986-1
LTC2990	Quad I ² C Temperature, Voltage and Current Monitor	Remote and Internal Temperatures, 14-Bit Voltages and Current, Internal 10ppm/°C Reference
LTC2991	Octal I ² C Voltage, Current, Temperature Monitor	Remote and Internal Temperatures, 14-Bit Voltages and Current, Internal 10ppm/°C Reference
LTC2995	Temperature Sensor and Voltage Monitor with Alert Outputs	Monitors Temperature and Two Voltages, Adjustable Thresholds, Open-Drain Alert Outputs, Temperature to Voltage Output with Integrated 1.8V Reference, ±1°C (Max) Accuracy
LTC2996	Temperature Sensor with Alert Outputs	Monitors Temperature, Adjustable Thresholds, Open-Drain Alert Outputs, Temperature to Voltage Output with Integrated 1.8V Reference, ±1°C (Max) Accuracy
LTC2997	Remote/Internal Temperature Sensor	Temperature to Voltage Output with Integrated 1.8V Reference, ±1°C (Max) Accuracy
LTC2943	20V I ² C Coulomb Counter	Monitors Charge, Current, Voltage and Temperature with 1% Accuracy. Works with Any Battery Chemistry and Capacity

Looking for pricing, stock, or lifecycle information?

Click below to explore more details on WIN SOURCE:

 [View LTM2985IY#PBF on WIN SOURCE](#)

 [Analog Devices Inc. Information](#)

Optimize Your Supply Chain with WIN SOURCE Solutions

-  Global Sourcing Solution
-  Obsolete Management
-  Cost Control Management
-  Shortage Management
-  Alternative Solution
-  Excess Inventory Management