



**THE DATASHEET OF  
TLE493DW2B6A3HTSA1**



# TLE493D-W2B6

## Low Power 3D Hall Sensor with I<sup>2</sup>C Interface and Wake Up Function

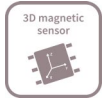

ISO26262  
ready

### 1 Overview

Quality Requirement Category: Automotive | Industry

#### Features

- 3D magnetic flux density sensing of  $\pm 160$  mT.
- Programmable flux resolution down to  $65 \mu\text{T}$  (typ.).
- X-Y angular measurement mode
- Diagnostic measurements to check digital parts, analog parts and Hall probe of the sensor
- Power down mode with  $7 \text{ nA}$  (typ) power consumption
- 12-bit data resolution for each measurement direction plus 10-bit temperature sensor
- Variable update frequencies and power modes (configurable during operation)
- Temperature range  $T_j = -40^\circ\text{C} \dots 125^\circ\text{C}$ , supply voltage range =  $2.8 \text{ V} \dots 3.5 \text{ V}$
- Triggering by external  $\mu\text{C}$  possible via I<sup>2</sup>C protocol
- Interrupt signal to indicate a valid measurement to the microcontroller

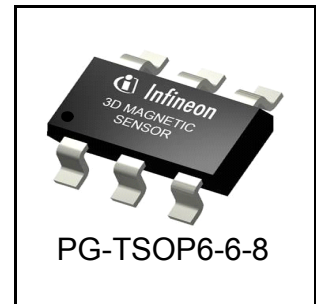

#### Applications

The TLE493D-W2B6 is designed for all kinds of sensing applications, including the following:

- Gear stick position
- Control elements in the top column module and multi function steering wheel
- Multi function knobs
- Pedal/valve position sensing

#### Benefits

- Component reduction due to 3D magnetic measurement principle
- Wide application range addressable due to high flexibility
- Platform adaptability due to device configurability
- Supporting functional safety by means of integrated diagnostics
- Very low system power consumption due to Wake Up mode
- Disturbance of smaller stray fields are neglectable compared to the high magnetic flux measurement range

---

**Overview****Table 1    Ordering Information**

Product Type	Marking <sup>1)</sup>	Ordering Code	Package	Default address write / read
TLE493D-W2B6 A0	EC	SP001605334	PG-TSOP6-6-8	6A <sub>H</sub> / 6B <sub>H</sub>
TLE493D-W2B6 A1	ED	SP001605340	PG-TSOP6-6-8	44 <sub>H</sub> / 45 <sub>H</sub>
TLE493D-W2B6 A2	EE	SP001605344	PG-TSOP6-6-8	F0 <sub>H</sub> / F1 <sub>H</sub>
TLE493D-W2B6 A3	EF	SP001605348	PG-TSOP6-6-8	88 <sub>H</sub> / 89 <sub>H</sub>

1) Engineering samples are marked with "SA".

## Table of Contents

<b>1</b>	<b>Overview</b> .....	<b>1</b>
<b>2</b>	<b>Functional Description</b> .....	<b>4</b>
2.1	General .....	4
2.1.1	Power mode control .....	4
2.1.2	Sensing .....	5
2.1.3	Wake Up .....	5
2.2	Pin Configuration (top view) .....	5
2.3	Definition of Magnetic Field .....	6
2.4	Sensitive Area .....	6
2.5	Application Circuit .....	7
<b>3</b>	<b>Specification</b> .....	<b>8</b>
3.1	Absolute Maximum Ratings .....	8
3.2	Operating Range .....	9
3.3	Electrical Characteristics .....	10
3.4	Magnetic Characteristics .....	11
3.5	Temperature Measurement .....	13
3.6	Overview of Modes .....	14
3.7	Interface and Timing Description .....	15
<b>4</b>	<b>Package Information</b> .....	<b>17</b>
4.1	Package Parameters .....	17
4.2	Package Outlines .....	18
<b>5</b>	<b>Revision History</b> .....	<b>20</b>

## Functional Description

## 2 Functional Description

This three dimensional Hall effect sensor can be configured by the microcontroller. The measurement data is provided in digital format to the microcontroller. The microcontroller is the master and the sensor is the slave. It also provides test functions and the capability to wake up a sleeping system.

### 2.1 General

Description of the Block diagram and its functions.

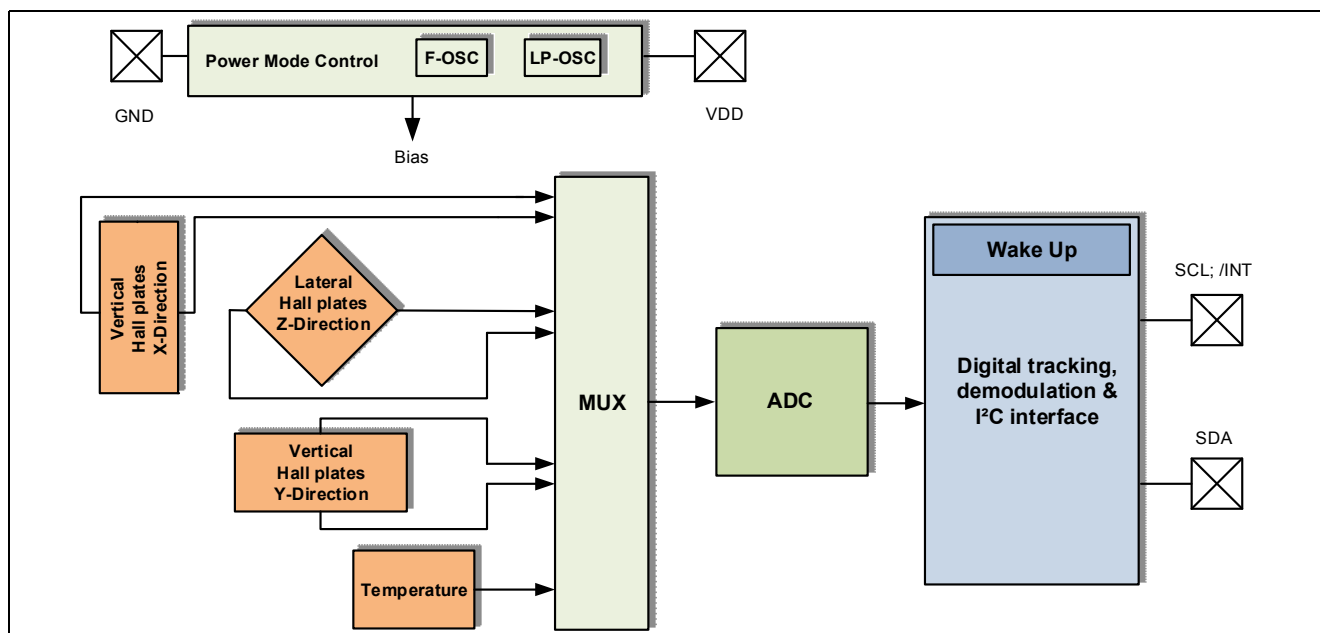

**Figure 1** Block Diagram

The IC consists of three main functional units containing the following building blocks:

- The power mode control system, containing a low-power oscillator, basic biasing, accurate restart, undervoltage detection and a fast oscillator.
- The sensing unit, which contains the HALL biasing, HALL probes with multiplexers and successive tracking ADC, as well as a temperature sensor is implemented.
- The I<sup>2</sup>C interface, containing the register files and I/O pads

#### 2.1.1 Power mode control

The power mode control provides the power distribution in the IC, a power-on reset function and a specialized low-power oscillator as the clock source. It also manages the start-up behavior.

- On start-up, this unit:
  - activates the biasing, provides an accurate reset detector and fast oscillator
  - sensor enters low power mode and can be configured via I<sup>2</sup>C interface
- After re-configuration, a measurement cycle is performed, which consists of the following steps:
  - activating internal biasing, checking for the restart condition and providing the fast oscillator
  - HALL biasing
  - measuring the three HALL probe channels sequentially (including the temperature). This is enabled by default
  - reentering configured mode

## Functional Description

In any case functions are only executed if the supply voltage is high enough, otherwise the restart circuit will halt the state machine until the required level is reached and restart afterwards. The functions are also restarted if a restart event occurs in between (see parameter [ADC restart level](#)).

### 2.1.2 Sensing

Measures the magnetic field in X, Y and Z direction. Each X-, Y- and Z-Hall probe is connected sequentially to a multiplexer, which is then connected to an Analog to Digital Converter (ADC). Optional, the temperature (default = activated) can be determined as well after the three Hall channels.

### 2.1.3 Wake Up

For each of the three magnetic channels (X/Y/Z), the Wake Up function has an upper and lower comparison threshold. Each component of the applied field is compared to the lower and upper threshold. If one of the results is above or below these thresholds, an interrupt pulse /INT is generated. This is called a Wake Up function. The sensor signals a certain field strength change to the microcontroller. As long as all components of the field stay within the envelope, no interrupt signal will be provided. Note however that the /INT can also be inhibited during I<sup>2</sup>C activities, by activated collision avoidance. An Wake Up interrupt /INT is the logical OR among all Wake Up interrupt envelopes of the three channels.

## 2.2 Pin Configuration (top view)

[Figure 2](#) shows the pinout of the TLE493D-W2B6.

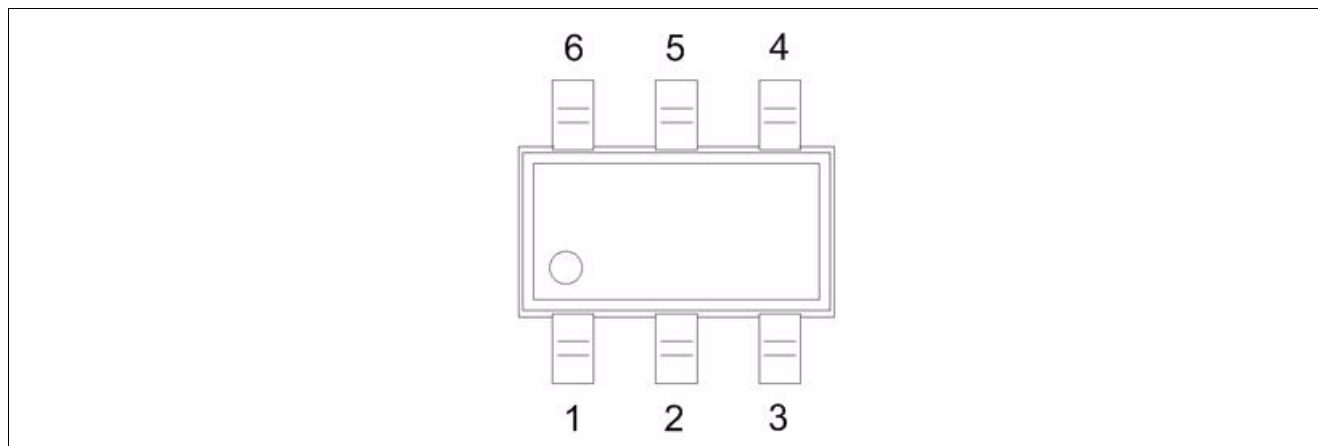

**Figure 2** TLE493D-W2B6 pinout

**Table 2** TSOP6 pin description and configuration (see [Figure 2](#))

Pin No.	Name	Description
1	SCL /INT	Interface serial clock pin (input) Interrupt pin, signals a finished measurement cycle, open-drain
2	GND	Connect to GND
3	GND	Ground Pin
4	VDD	Supply Pin
5	GND	Connect to GND
6	SDA	Interface serial data pin (input/output), open-drain

Functional Description

### 2.3 Definition of Magnetic Field

A positive field is considered as South-Pole facing the corresponding Hall element.

Figure 3 shows the definition of the magnetic directions X, Y, Z of the TLE493D-W2B6.

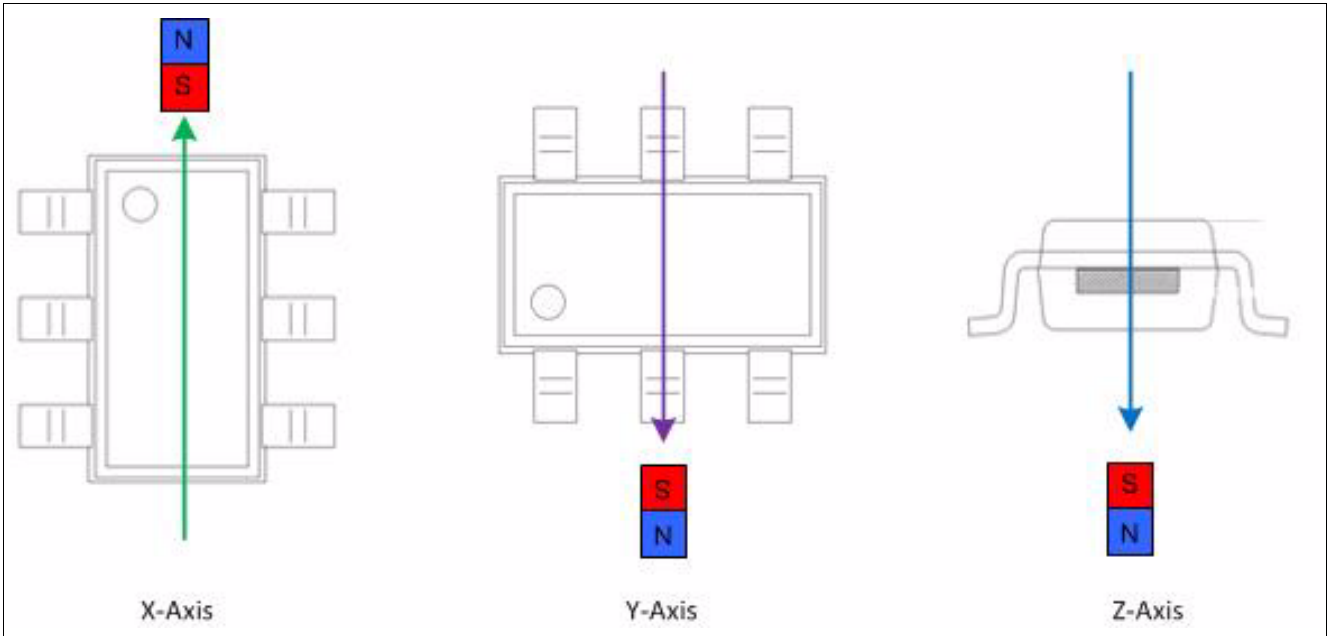

Figure 3 Definition of Magnetic Field Direction

### 2.4 Sensitive Area

The magnetic sensitive area for the Hall measurement is shown in Figure 4.

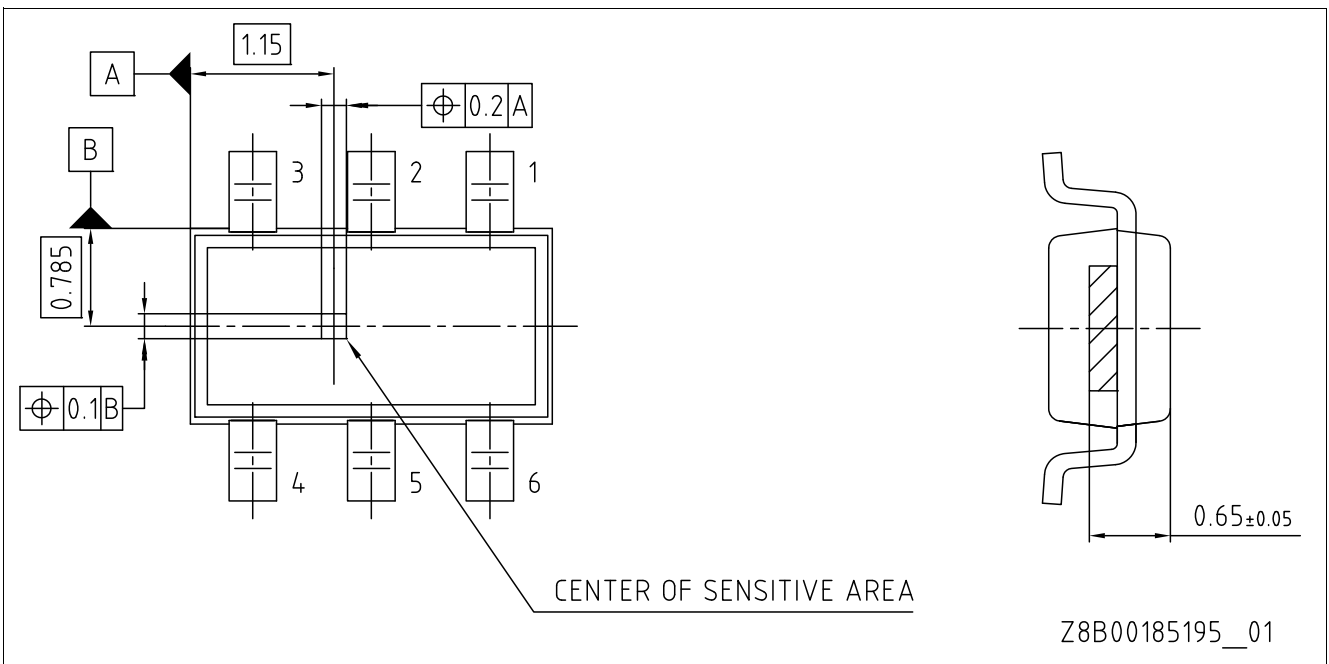

Figure 4 Center of Sensitive Area (dimensions in mm)

## Functional Description

### 2.5 Application Circuit

The use of an interrupt line is optional, but highly recommended to ensure proper and efficient readout of the sensor data.

The pull-up resistor values of the I<sup>2</sup>C bus have to be calculated in such a way as to fulfill the rise- and fall time specification of the interface for the given worst case parasitic (capacitive) load of the actual application setup.

Please note: too small resistive R1/2 values have to be prevented to avoid unnecessary power consumption during interface transmissions, especially for low-power applications.

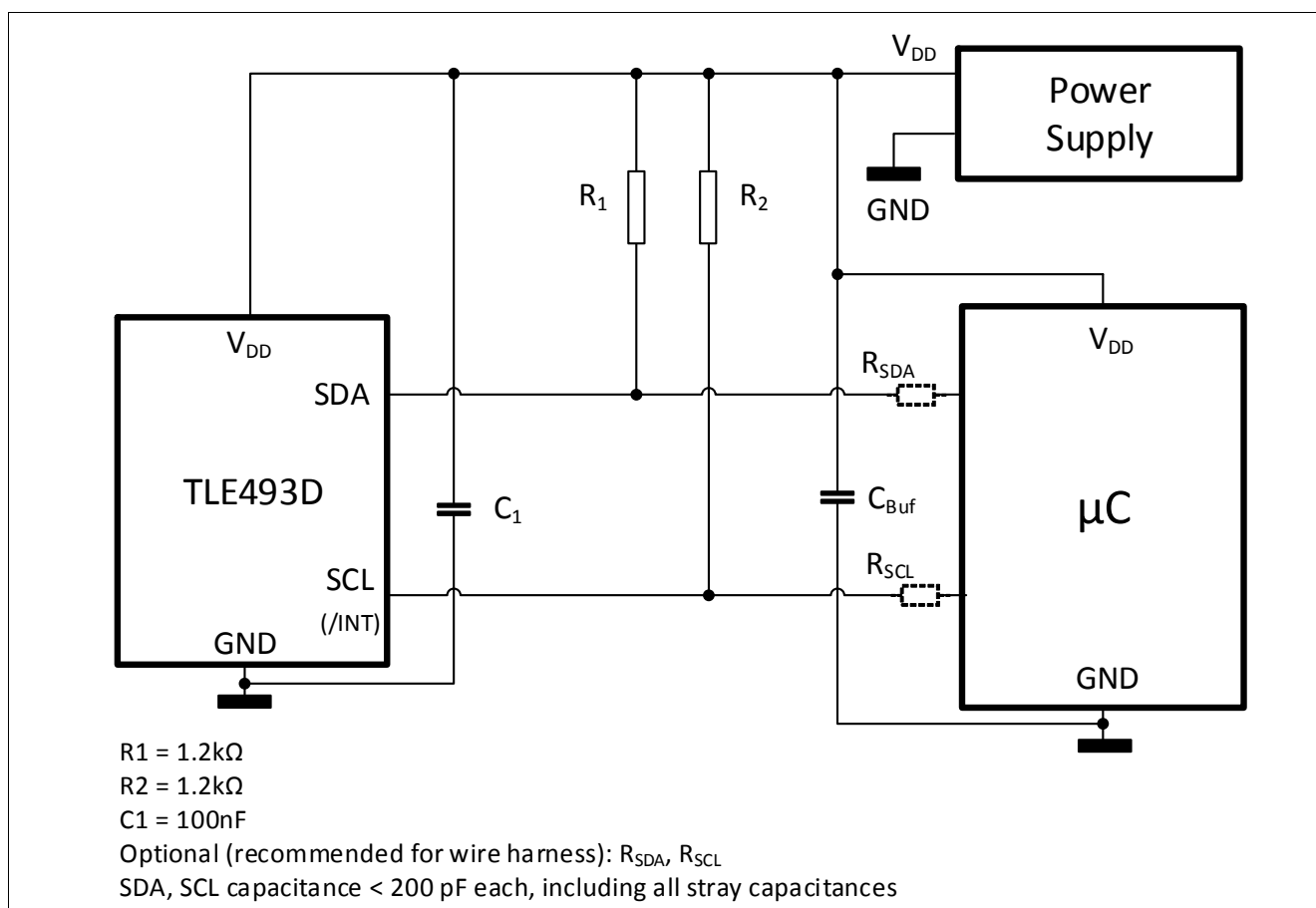

**Figure 5** Application Circuit with external power supply and  $\mu C$

For additional EMC precaution in harsh environments,  $C_1$  may be implemented by two 100 nF capacitors in parallel, which should be already given by  $C_{Buf}$  near the  $\mu C$  and/or power supply.

## Specification

### 3 Specification

This sensor is intended to be used in an automotive environment. This chapter describes the environmental conditions required by the device (magnetic, thermal and electrical).

#### 3.1 Absolute Maximum Ratings

Stresses above those listed under “Absolute Maximum Ratings” may cause permanent damage to the device. This is a stress rating only and functional operation of the device at these or any other conditions above those indicated in the operational sections of this specification is not implied. Furthermore, only single error cases are assumed. More than one stress/error case may also damage the device.

Exposure to absolute maximum rating conditions for extended periods may affect device reliability. During absolute maximum rating overload conditions the voltage on  $V_{DD}$  pin with respect to ground (GND) must not exceed the values defined by the absolute maximum ratings.

**Table 3 Absolute Maximum Ratings**

Parameter	Symbol	min	typ	max	Unit	Note/Condition
Junction temperature	$T_j$	-40	–	125	°C	
Voltage on $V_{DD}$	$V_{DD}$	-0.3	–	3.5	V	
Magnetic field	$B_{max}$	–	–	±1	T	
Voltage range on any pin to GND	$V_{max}$	-0.1	–	3.5	V	open-drain outputs are not current limited.

**Table 4 ESD Protection<sup>1)</sup>**

Ambient temperature  $T_A = 25^\circ\text{C}$

Parameter	Symbol	Values			Unit	Note or Test Condition
		Min.	Typ.	Max.		
ESD voltage (HBM) <sup>2)</sup>	$V_{ESD}$	–	–	±2.0	kV	$R = 1.5\text{ k}\Omega, C = 100\text{ pF}$
ESD voltage (CDM) <sup>3)</sup>		–	–	±0.75	kV	for corner pins
		–	–	±0.5	kV	all pins

- 1) Characterization of ESD is carried out on a sample basis, not subject to production test.
- 2) Human Body Model (HBM) tests according to ANSI/ESDA/JEDEC JS-001.
- 3) Charged Device Model (CDM), ESD susceptibility according to JEDEC JESD22-C101.

## Specification

### 3.2 Operating Range

To achieve ultra low power consumption, the chip does not use a conventional, power-consuming restart procedure. The focus of the restart procedure implemented is to ensure a proper supply for the ADC operation only. So it inhibits the ADC until the sensor supply is high enough.

**Table 5** Operating Range

Parameter	Symbol	min	typ	max	Unit	Note/Condition
Operating temperature	$T_j$	-40	–	125	°C	$T_j = T_a + 3$ K in fast mode
Supply voltage	$V_{DD}$	2.8	3.3	3.5	V	Supply voltage must be above restart level
ADC restart level	$V_{res}$	2.2	2.5	2.8	V	min. ADC operating level
ADC restart hysteresis	$V_{res-hys}$	–	50	–	mV	
Register stable level	$V_{reg}$	–	–	2.5	V	Register values are stable above this voltage level

The sensor relies on a proper supply ramp defined with  $t_{PUP}$ ,  $V_{OUS}$  and  $I_{DD-PUP}$ , see [Figure 6](#). The I<sup>2</sup>C reset feature of the sensor shall be used by the  $\mu$ C after Power Up. If supply monitoring is used in the system (e.g. brown-out detector etc.), it is also recommended to use the I<sup>2</sup>C reset of the sensor following events detected by this monitor.

In any case, an external supply switch (either provided by a System-Basis-Chip solution which includes a supply-enable feature, a Bias-Resistor-Transistor device, a capable  $\mu$ C GPIO pin, etc.) shall allow a power-cycle of the sensor as backup for high availability applications to cope with any form of  $V_{DD}$  ramps (including potential EMC influences), see [Figure 6](#).

At Power Up, SDA and SCL shall be pulled to  $V_{DD}$  using R1 and R2 of [Figure 5](#) and not be driven to low by any device or  $\mu$ C on SDA and SCL.

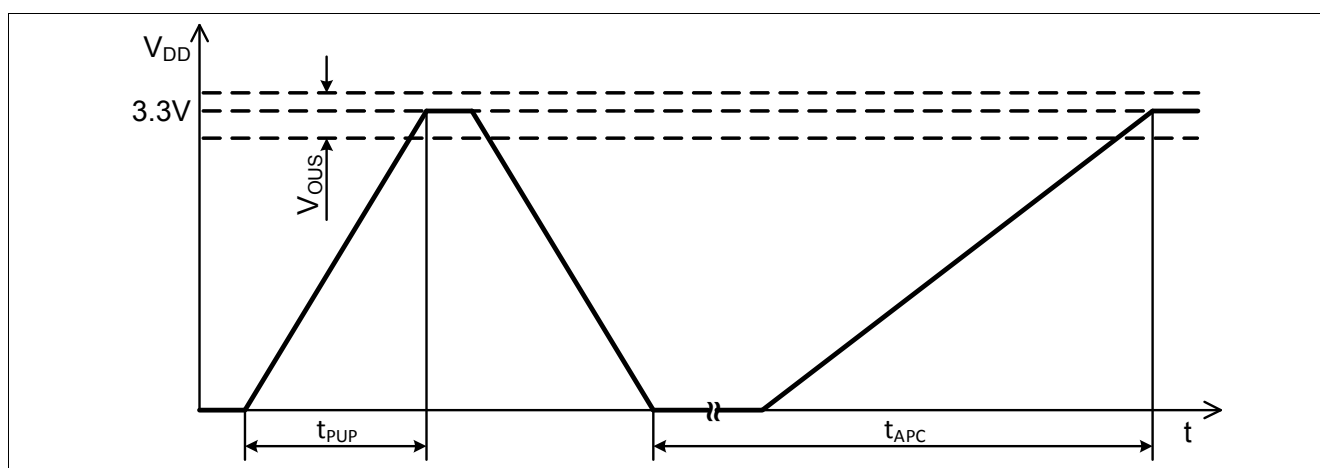

**Figure 6**  $V_{DD}$  power up and power-cycle for high availability

## Specification

**Table 6**  $V_{DD}$  power up and power-cycle

Parameter	Symbol	min	typ	max	Unit	Note/Condition
Power Up ramp time	$t_{PUP}$	–	–	10	$\mu\text{s}$	
Availability power cycle <sup>1)</sup>	$t_{APC}$	–	150	400	$\mu\text{s}$	
Power Up over-undershoot	$V_{OUS}$	3	3.3	3.5	V	Envelope which must not be exceeded at the end of a Power Up.
Power Up current consumption	$I_{DD-PUP}$	–		10	mA	Current consumption during $t_{PUP}$

1) Not subject to production test - verified by design.

### 3.3 Electrical Characteristics

This sensor provides different operating modes and a digital communication interface. The corresponding electrical parameters are listed in [Table 7](#). Regarding current consumption more information are available in [Chapter 3.6](#).

**Table 7** Electrical Setup

Values for  $V_{DD} = 3.3 \text{ V} \pm 5 \%$ ,  $T_j = -40^\circ\text{C}$  to  $+125^\circ\text{C}$  (unless otherwise specified)

Parameter	Symbol	min	typ	max	Unit	Note/Condition
Supply current <sup>1)</sup>	$I_{DD\_pd}$	–	7	130	nA	$T_j = 25^\circ\text{C}$ ; power down mode
	$I_{DD\_fm}$	1	3.4	5	mA	Fast mode
Input voltage low threshold <sup>2)</sup>	$V_{IL}$	–	–	30	$\%V_{DD}$	all input pads
Input voltage high threshold <sup>2)</sup>	$V_{IH}$	70	–	–	$\%V_{DD}$	all input pads
Input voltage hysteresis <sup>2)</sup>	$V_{IHYS}$	5	–		$\%V_{DD}$	all input pads
Output voltage low level @ 3 mA load	$V_{OL}$	–	–	0.4	V	all output pads, static load

1) Currents at pull up resistors ([Figure 5](#)) needs to be considered for power supply dimensioning.

2) Based on I<sup>2</sup>C standard 1995 for  $V_{DD}$  related input levels

## Specification

### 3.4 Magnetic Characteristics

The magnetic parameters are specified for an end of line production scenario and for an application life time scenario.

The magnetic measurement values are provided in the two's complement with 12 bit or 8 bit resolution in the registers with the symbols B<sub>x</sub>, B<sub>y</sub> and B<sub>z</sub>. Two examples, how to calculate the magnetic flux are shown in [Table 11](#) and [Table 12](#).

**Table 8 Initial Magnetic Characteristics<sup>1)</sup>**

Values for T<sub>j</sub> = +25°C, 0 h and V<sub>DD</sub> = 3.3 V (unless otherwise specified)

Parameter	Symbol	min	typ	max	Unit	Note/Condition
Magnetic linear range <sup>2)</sup> (full range)	B <sub>xyz_LIN</sub>	±160	±200	±230	mT	-40°C < T <sub>j</sub> < +125°C
Magnetic linear range <sup>2)3)</sup> (short range)	B <sub>xyz_LINSR</sub>	±100	±135	±150	mT	
Sensitivity X, Y, Z (full range)	S <sub>X</sub> , S <sub>Y</sub> , S <sub>Z</sub>	5.5	7.7	10.5	LSB <sub>12</sub> / mT	
Sensitivity X, Y, Z (short range)	S <sub>X<sub>SR</sub></sub> , S <sub>Y<sub>SR</sub></sub> , S <sub>Z<sub>SR</sub></sub>	11	15.4	21		
Z-Offset (full range and short range)	B <sub>0Z</sub>	-1.8	±0.2	+1.8	mT	
XY-Offset (full range and short range)	B <sub>0xy</sub>	-0.75	±0.2	+0.75	mT	
X to Y magnetic matching <sup>4)</sup>	M <sub>XY</sub>	-15	±1	+15	%	Up to min.
X/Y to Z magnetic matching <sup>4)</sup>	M <sub>X/YZ</sub>	-25	0	+25	%	B <sub>xyz_LIN</sub> or B <sub>xyz_LINSR</sub>
Resolution, 12-bit <sup>5)</sup> (full range)	Res <sub>12</sub>	95	130	182	μT/ LSB <sub>12</sub>	
Resolution, 12-bit <sup>5)</sup> (short range)	Res <sub>12_SR</sub>	47.5	65	91		
Resolution, 8-bit <sup>5)</sup> (full range)	Res <sub>8</sub>	1.52	2.08	2.91	mT/ LSB <sub>8</sub>	
Resolution, 8-bit <sup>5)</sup> (short range)	Res <sub>8_SR</sub>	0.76	1.04	1.46		
Magnetic initial noise (rms) (full range and short range)	B <sub>ineff</sub>	-	0.1	0.5	mT	rms = 1 sigma
Magnetic hysteresis <sup>2)</sup> (full range and short range)	B <sub>HYS</sub>	-	1	-	LSB <sub>12</sub>	due to quantization effects

- 1) Magnetic test on wafer level. It is assumed that initial variations are stored and compensated in the external μC during module test and calibration.
- 2) Not subject to production test - verified by design/characterization.
- 3) The short range setting does not have an analogue saturation behavior due to internal offsets and the compensation thereof.
- 4) See the magnetic matching definition in [Equation \(3.1\)](#) and [Equation \(3.2\)](#).
- 5) Resolution is calculated as 1/Sensitivity (and multiplied by 16 for 8-bit value).

Equation for parameter “X to Y magnetic matching”: (3.1)

$$M_{XY} = 100 \cdot 2 \cdot \frac{S_x - S_y}{S_x + S_y} [\%]$$

Equation for parameter “X/Y to Z magnetic matching”: (3.2)

$$M_{X/YZ} = 100 \cdot 2 \cdot \frac{S_x + S_y - 2 \cdot S_z}{S_x + S_y + 2 \cdot S_z} [\%]$$

## Specification

**Table 9** Sensor Drifts<sup>1)</sup> valid for both full range and short range (unless indicated)

Values for  $V_{DD} = 3.3 \text{ V} \pm 5 \%$ ,  $T_j = -40^\circ\text{C}$  to  $125^\circ\text{C}$ , static magnetic field within full magnetic linear range (unless otherwise specified)

Parameter	Symbol	min	typ	max	Unit	Note/Condition
Sensitivity drift X, Y, Z	$S_{X_D}, S_{Y_D}, S_{Z_D}$	-15	$\pm 5$	+15	%	$TC_0$
Offset drift X, Y	$B_{O\_DXY}$	-0.45	-	+0.45	mT	@ 0 mT, $TC_0$
Offset drift Z	$B_{O\_DZ}$	-1.6	-	+1.6	mT	@ 0 mT, $TC_0$
Offset drift Z	$B_{O\_DZ}$	-0.45	-	+0.45	mT	@ 0 mT, $TC_0$ , Z Hall spintest
X to Y magnetic matching drift <sup>2)</sup>	$M_{XY\_D}$	-3.5	$\pm 1$	+3.5	%	$TC_0$
X/Y to Z magnetic matching drift <sup>2)</sup>	$M_{X/YZ\_D}$	-15	$\pm 10$	+15	%	$TC_0$

- 1) Not subject to production test, verified by design/characterization. Drifts are changes from the initial characteristics due to external influences.
- 2) See the magnetic matching definition in [Equation \(3.1\)](#) and [Equation \(3.2\)](#).

**Table 10** Temperature compensation, non-linearity and noise<sup>1)</sup>

Values for  $V_{DD} = 3.3 \text{ V} \pm 5 \%$ ,  $T_j = -40^\circ\text{C}$  to  $125^\circ\text{C}$  (unless otherwise specified)

Parameter	Symbol	min	typ	max	Unit	Note/Condition
Temperature compensation <sup>2)</sup> (full range and short range)	$TC_0$	-	$\pm 0$	-	ppm/K	Bx, By and Bz (default)
	$TC_1$	-	-750	-		Bx, By and Bz (option 1)
	$TC_2$	-	-1500	-		Bx, By and Bz (option 2)
	$TC_3$	-	+350	-		Bx, By and Bz (option 3)
Differential Non Linearity (full range)	$DNL$	-	$\pm 2$	-	$LSB_{12}$	Bx, By and Bz
Differential Non Linearity (short range)	$DNL_{SR}$	-	$\pm 4$	-		
Integral Non Linearity (full range)	$INL$	-	$\pm 2$	-	$LSB_{12}$	Bx, By and Bz
Integral Non Linearity (short range)	$INL_{SR}$	-	$\pm 4$	-	$LSB_{12}$	Bx, By and Bz
Magnetic noise (rms)	$B_{Neff}$	-	-	1	mT	rms = 1 sigma
Z-Magnetic noise (rms)	$B_{NeffZ}$	-	-	0.5	mT	rms = 1 sigma, $-40^\circ\text{C} < T_j < +85^\circ\text{C}$
XY-Magnetic noise (rms)	$B_{NeffXY}$	-	-	0.25	mT	

- 1) Not subject to production test, verified by design/characterization.
- 2)  $TC_x$  must be set before magnetic flux trimming and measurements with the same value.

## Specification

### Conversion register value to magnetic field value:

**Table 11 Magnetic conversion table for 12Bit**

	MSB	Bit10	Bit9	Bit8	Bit7	Bit6	Bit5	Bit4	Bit3	Bit2	Bit1	LSB
[Dec]	-2048	1024	512	256	128	64	32	16	8	4	2	1
[Bin] e.g.	1	1	1	1	0	0	0	0	1	1	1	1

The conversion is realized by the two's complement. Please use following table for transformation:

Example for 12-bit read out:  $1111\ 0000\ 1111_B$ :  $-2048 + 1024 + 512 + 256 + 0 + 0 + 0 + 0 + 8 + 4 + 2 + 1 = -241\ \text{LSB}_{12}$

Calculation of magnetic flux:  $-241\ \text{LSB}_{12} * 0.13\ \text{mT/LSB}_{12} = -31.3\ \text{mT}$

**Table 12 Magnetic conversion table for 8Bit**

	MSB	Bit10	Bit9	Bit8	Bit7	Bit6	Bit5	LSB
[Dec]	-128	64	32	16	8	4	2	1
[Bin] e.g.	0	1	0	1	1	1	0	1

Example for 8-bit read out:  $0101\ 1101_B$ :  $0 + 64 + 0 + 16 + 8 + 4 + 0 + 1 = 93\ \text{LSB}_8$

Calculation of magnetic flux:  $93\ \text{LSB}_8 * 2.08\ \text{mT/LSB}_8 = 193.4\ \text{mT}$

## 3.5 Temperature Measurement

By default, the temperature measurement is activated. The temperature measurement can be disabled if it is not needed and to increase the speed of repetition of the magnetic values.

**Table 13 Temperature Measurement Characteristics<sup>1)</sup>**

Parameter	Symbol	min	typ	max	Unit	Note/Condition
Digital value @ 25°C	$T_{25}$	1000	1180	1360	$\text{LSB}_{12}$	
Temperature resolution, 12-bit	$T_{\text{Res}12}$	0.21	0.24	0.27	$\text{K/LSB}_{12}$	referring to $T_j$
Temperature resolution, 8-bit	$T_{\text{Res}8}$	–	3.84	–	$\text{K/LSB}_8$	referring to $T_j$

1) The temperature measurement is not trimmed on the sensor. An external  $\mu\text{C}$  can measure the sensor during module production and implement external trimming to gain higher accuracies.

Temperature values are based on 12 bit resolution. Please note: only bit 11 ... 2 are listed in the bitmap registers.

**Table 14 Temperature conversion table for 12Bit**

The bits MSB to Bit2 are read out from the temperature value registers. Bit1 and LSB are added to get a 12-bit value for calculation.

	MSB	Bit10	Bit9	Bit8	Bit7	Bit6	Bit5	Bit4	Bit3	Bit2
[Dec]	-2048	1024	512	256	128	64	32	16	8	4
[Bin] e.g.	0	1	0	1	0	0	1	0	1	1

Example for 12-bit calculation:  $0110\ 1010\ 11_B$ :  $0 + 1024 + 0 + 256 + 0 + 0 + 32 + 0 + 8 + 4 = 1324\ \text{LSB}_{12}$

Calculation to temperature:  $(1324\ \text{LSB}_{12} - 1180\ \text{LSB}_{12}) * 0.24\ \text{K/LSB}_{12} + 25^\circ\text{C} \approx 60^\circ\text{C}$

## Specification

### 3.6 Overview of Modes

For a good adaptation on application requirements this sensor is equipped with different modes. An overview is listed in [Table 15](#).

**Table 15** Overview of modes<sup>1)</sup>

Mode	Measurements	Typ. $f_{Update}$ <sup>2)</sup>	Description
Power Down	No measurements	–	Lowest possible supply current $I_{DD}$ .
Low Power Mode (full range and short range)	Bx, By, Bz, T	0.05 Hz - 770 Hz (8 steps)	Cyclic measurements and ADC-conversions with different update rates.
	Bx, By, Bz		
	Bx, By		
Fast Mode (full range)	Bx, By, Bz, T	5.7 kHz	Measurements and ADC conversions are running continuously. An I <sup>2</sup> C clock speed $\geq 800$ kHz and use of the interrupt /INT is required.
	Bx, By, Bz	7.5 kHz	
	Bx, By	8.4 kHz	
Fast Mode (short range)	Bx, By, Bz, T	4.2 kHz	
	Bx, By, Bz	5.5 kHz	
	Bx, By	6.2 kHz	
Master-Controlled Mode (full range and short range)	Bx, By, Bz, T	Up to Fast Mode values.	Measurements triggered by the microcontroller via I <sup>2</sup> C.
	Bx, By, Bz		
	Bx, By		

1) Not subject to production test - verified by design/characterization.

2) This is the frequency at which specified measurements are updated.

I<sup>2</sup>C triggered Master-Controlled Mode typical  $I_{DD}$  current consumption estimation formula:

Equation  $I_{DD}$  full range (3.3)

$$I_{DD} \approx I_{DD.fm} \cdot 0.18 \text{ ms} \cdot f_{Update}$$

Equation  $I_{DD}$  short range (3.4)

$$I_{DD} \approx I_{DD.fm} \cdot 0.24 \text{ ms} \cdot f_{Update}$$

The average supply current  $I_{DD}$  in the 8 Low Power Modes and I<sup>2</sup>C triggered mode will decrease by about 25 % if the temperature measurement is disabled and will decrease by about 50% if the temperature and Bz measurement is disabled.

## Specification

### 3.7 Interface and Timing Description

This chapter refers to how to set the boundary conditions in order to establish a proper interface communication.

**Table 16** Interface and timing<sup>1)</sup>

Parameter	Symbol	min	typ	max	Unit	Note/Condition
End of Conversion /INT pulse	$t_{INT}$	1.8	2.5	3.2	$\mu\text{s}$	low-active (when activated)
Time window to read first value (full range)	$t_{RD1}$	30	40	50	$\mu\text{s}$	read after rising /INT edge
Time window to read first value (short range)	$t_{RD1\_SR}$	42	56	70	$\mu\text{s}$	read after rising /INT edge
Time window to read next value (full range)	$t_{RDn}$	32	43	54	$\mu\text{s}$	consecutive reads
Time window to read next value (short range)	$t_{RDn\_SR}$	44	59	74	$\mu\text{s}$	consecutive reads
Internal clock accuracy	$t_{clk\_E}$	-25	-	+25	%	

#### I<sup>2</sup>C timings

Allowed I <sup>2</sup> C bit clock frequency <sup>2)</sup>	$f_{I2C\_clk}$	-	400	1000	kHz	
Low period of SCL clock	$t_L$	0.5	-	-	$\mu\text{s}$	1.3 $\mu\text{s}$ for 400-kHz mode
High period of SCL clock	$t_H$	0.4	-	-	$\mu\text{s}$	0.6 $\mu\text{s}$ for 400-kHz mode
SDA fall to SCL fall hold time (hold time start condition to clock)	$t_{STA}$	0.4	-	-	$\mu\text{s}$	0.6 $\mu\text{s}$ for 400-kHz mode
SCL rise to SDA rise su. time (setup time clock to stop condition)	$t_{STOP}$	0.4	-	-	$\mu\text{s}$	0.6 $\mu\text{s}$ for 400-kHz mode
SDA rise to SDA fall hold time (wait time from stop to start cond.)	$t_{WAIT}$	0.4	-	-	$\mu\text{s}$	0.6 $\mu\text{s}$ for 400-kHz mode
SDA setup before SCL rising	$t_{SU}$	0.1	-	-	$\mu\text{s}$	
SDA hold after SCL falling	$t_{HOLD}$	0	-	-	$\mu\text{s}$	
Fall time SDA/SCL signal <sup>3)</sup>	$t_{FALL}$	-	0.25	0.3	$\mu\text{s}$	
Rise time SDA/SCL signal <sup>3)</sup>	$t_{RISE}$	-	0.5	-	$\mu\text{s}$	R = 1.2 k $\Omega$

1) Not subject to production test - verified by design/characterization

2) Dependent on R-C-combination on SDA and SCL. Ensure reduced capacitive load for speeds above 400 kHz.

3) Dependent on used R-C-combination.

The fast mode, shown in [Figure 7](#), requires a very strict I<sup>2</sup>C behavior synchronized with the sensor conversions and high bit rates. In this mode, a fresh measurement cycle is started immediately after the previous cycle was completed.

Other modes are available for more relaxed timing and also for a synchronous microcontroller operation of sensor conversions. In these modes, a fresh measurement cycle is only started if it is triggered by an internal or external trigger source.

In the default measurement configuration (Bx, By, Bz and T), shown in [Figure 7](#), the measurement cycle ends after the temperature measurement.

In 3-channel measurement configuration (Bx, By and Bz), the temperature channel is not converted and updated. Thus, the measurement cycle ends after the Bz measurement.

Specification

In X/Y angular measurement configuration (Bx and By), the Bz and temperature channel are not converted and updated. Thus, the measurement cycle ends after the By measurement.

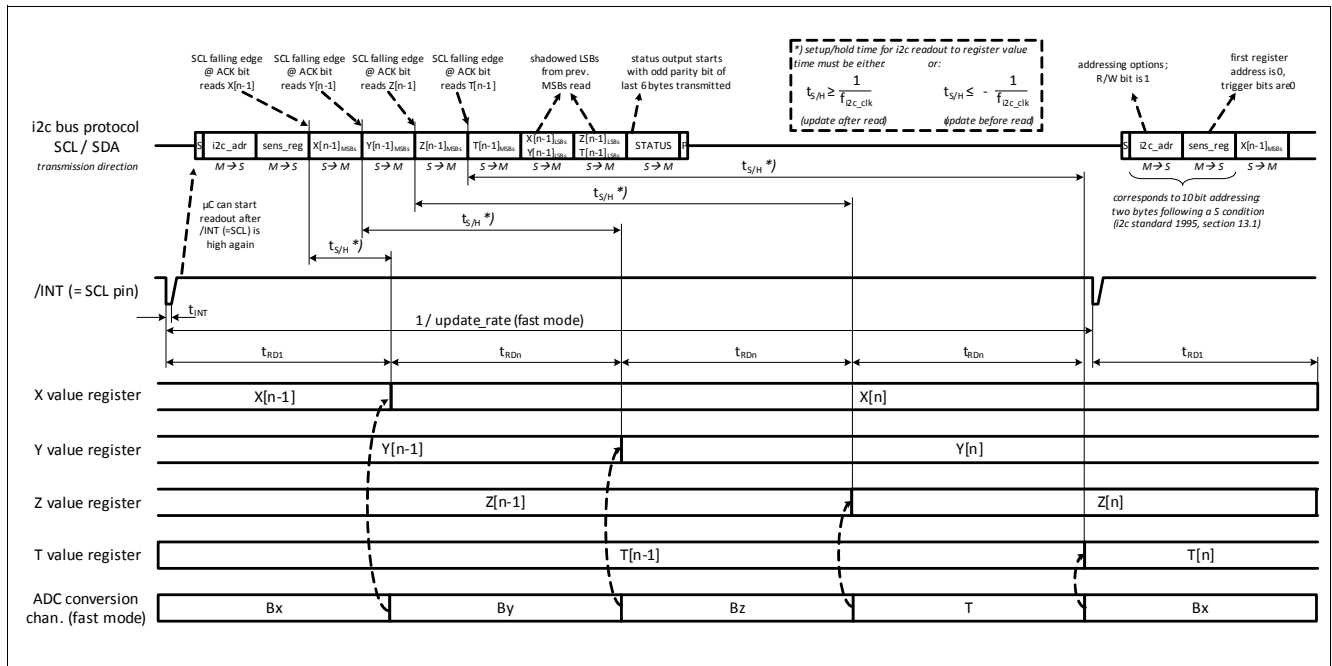

Figure 7 I<sup>2</sup>C readout frame, ADC conversion and related timing

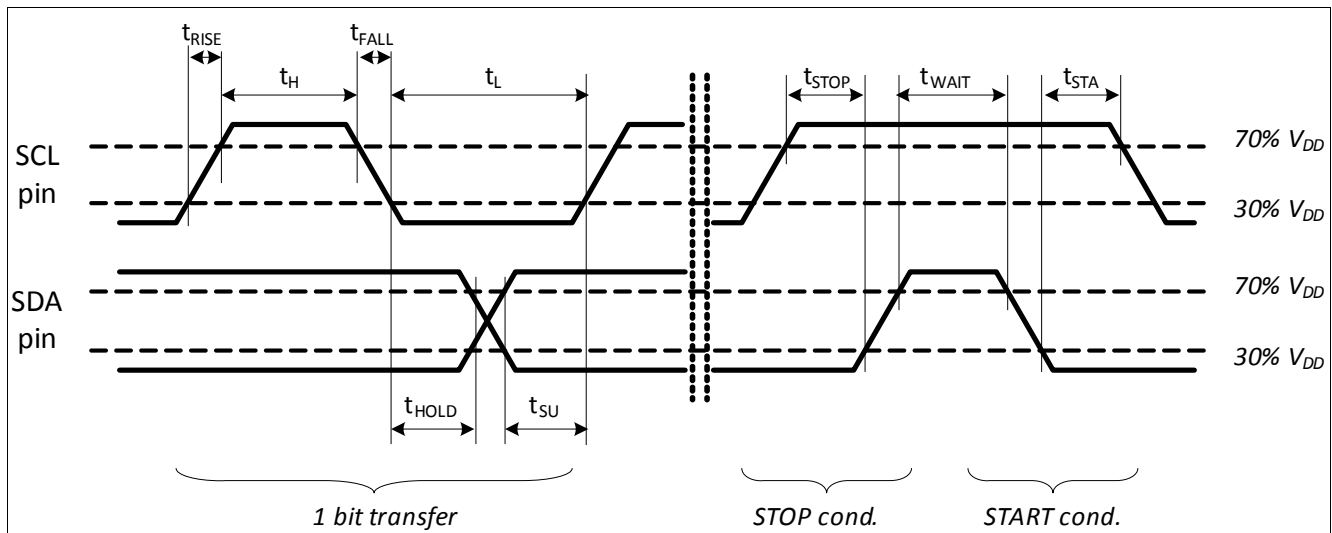

Figure 8 I<sup>2</sup>C timing specification

Package Information

## 4 Package Information

### 4.1 Package Parameters

Table 17 Package Parameters

Parameter	Symbol	Limit Values			Unit	Notes
		Min.	Typ.	Max.		
Thermal resistance <sup>1)</sup> Junction ambient	$R_{thJA}$	-	-	200	K/W	Junction to air for PG-TSOP-6-6-8
Thermal resistance Junction lead	$R_{thJL}$	-	-	100	K/W	Junction to lead for PG-TSOP-6-6-8
Soldering moisture level <sup>2)</sup>	MSL 1					260°C

1) According to Jecdec JESD51-7

2) Suitable for reflow soldering with soldering profiles according to JEDEC J-STD-020D.1 (March 2008)



Figure 9 Image of TLE493D-W2B6 in TSOP6

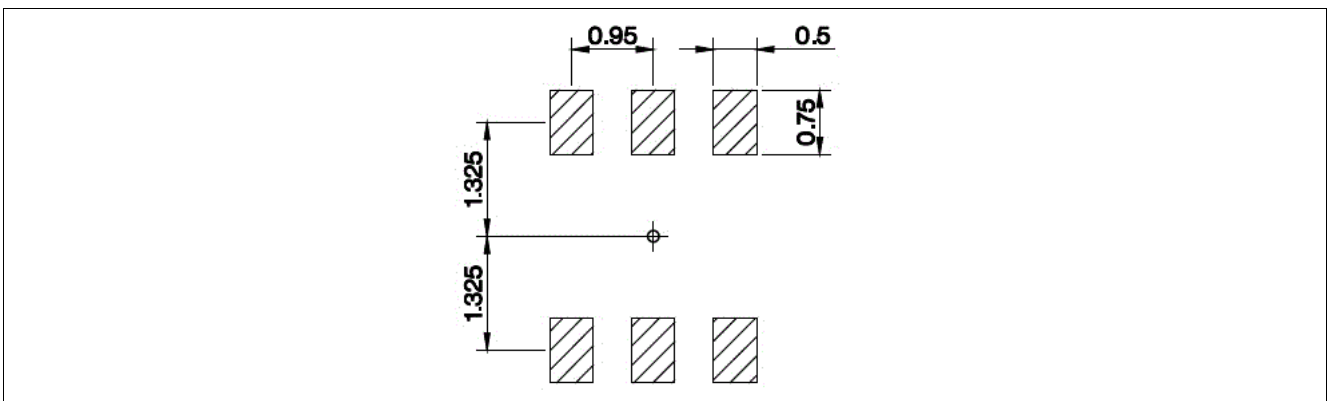

Figure 10 Footprint PG-TSOP6-6-8 (compatible to PG-TSOP6-6-5, all dimensions in mm)

Package Information

4.2 Package Outlines

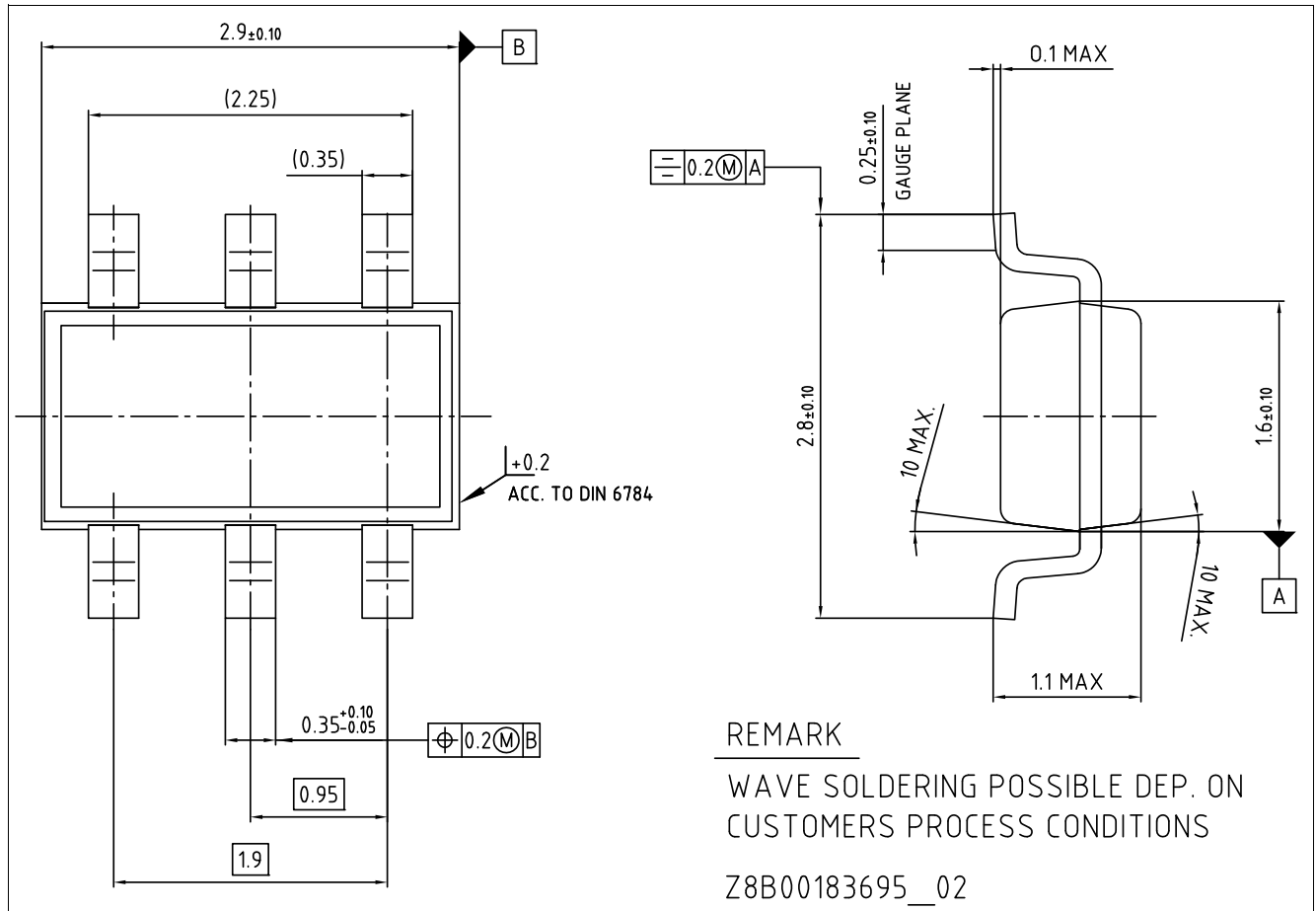

Figure 11 Package Outlines (all dimensions in mm)

Package Information

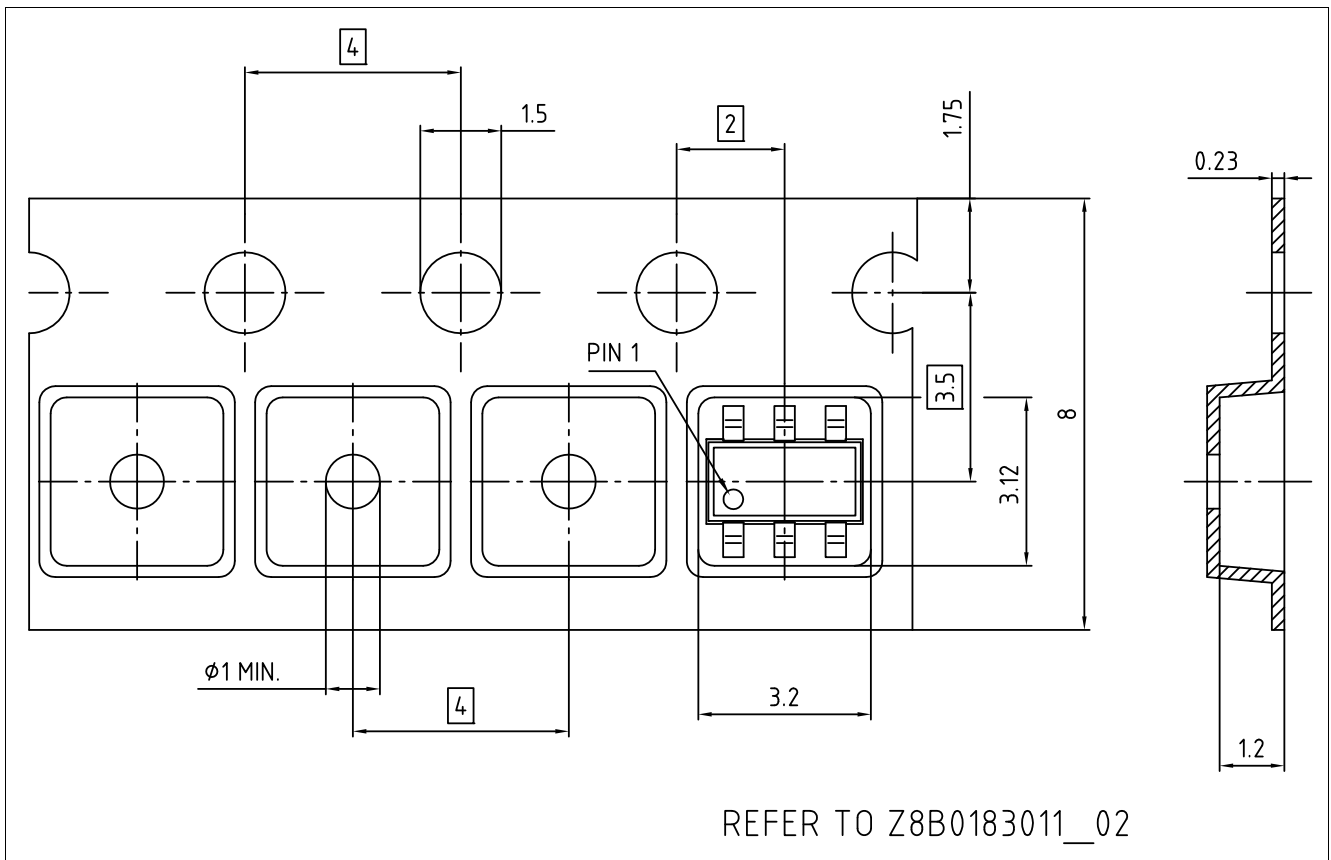

Figure 12 Packing (all dimensions in mm)

Further information about the package can be found here:

[http://www.infineon.com/cms/packages/SMD\\_-\\_Surface\\_Mounted\\_Devices/TSOP/TSOP6.html](http://www.infineon.com/cms/packages/SMD_-_Surface_Mounted_Devices/TSOP/TSOP6.html)

---

**Revision History****5 Revision History**

---

**Revision History**

Page or Item	Subjects (major changes since previous revision)
<b>Ver. 1.2, 2019-04-09</b>	
	<a href="#">Chapter 3.2</a> text "I <sup>2</sup> C reset" updated.
<b>Ver. 1.1, 2019-02-08</b>	
	<a href="#">Figure 4</a> , <a href="#">Figure 11</a> and <a href="#">Figure 12</a> updated.
<b>Ver. 1.0, 2018-01-24</b>	
	Initial version

## Trademarks

All referenced product or service names and trademarks are the property of their respective owners.

**Edition 2019-04-09**  
**Published by**  
**Infineon Technologies AG**  
**81726 Munich, Germany**

**© 2019 Infineon Technologies AG.**  
**All Rights Reserved.**

**Do you have a question about any aspect of this document?**

**Email: [erratum@infineon.com](mailto:erratum@infineon.com)**

**Document reference**

## IMPORTANT NOTICE

The information given in this document shall in no event be regarded as a guarantee of conditions or characteristics ("Beschaffheitsgarantie").

With respect to any examples, hints or any typical values stated herein and/or any information regarding the application of the product, Infineon Technologies hereby disclaims any and all warranties and liabilities of any kind, including without limitation warranties of non-infringement of intellectual property rights of any third party.

In addition, any information given in this document is subject to customer's compliance with its obligations stated in this document and any applicable legal requirements, norms and standards concerning customer's products and any use of the product of Infineon Technologies in customer's applications.

The data contained in this document is exclusively intended for technically trained staff. It is the responsibility of customer's technical departments to evaluate the suitability of the product for the intended application and the completeness of the product information given in this document with respect to such application.

For further information on technology, delivery terms and conditions and prices, please contact the nearest Infineon Technologies Office ([www.infineon.com](http://www.infineon.com)).

## WARNINGS

Due to technical requirements products may contain dangerous substances. For information on the types in question please contact your nearest Infineon Technologies office.

Except as otherwise explicitly approved by Infineon Technologies in a written document signed by authorized representatives of Infineon Technologies, Infineon Technologies' products may not be used in any applications where a failure of the product or any consequences of the use thereof can reasonably be expected to result in personal injury.

## Looking for pricing, stock, or lifecycle information?

Click below to explore more details on WIN SOURCE:

- ⊖ [View TLE493DW2B6A3HTSA1 on WIN SOURCE](#)
- ⊖ [Infineon Technologies Information](#)

## Optimize Your Supply Chain with WIN SOURCE Solutions

- ✓ Global Sourcing Solution
- ✓ Obsolete Management
- ✓ Cost Control Management
- ✓ Shortage Management
- ✓ Alternative Solution
- ✓ Excess Inventory Management