



**THE DATASHEET OF
ADS7066IYBHR**



ADS7066 Small, 8-Channel, 16-Bit, 250-kSPS SAR ADC With GPIOs

1 Features

- Small solution size:
 - DSBGA and WQFN packages
 - Space-saving, capless, 2.5-V internal reference
- 8 channels configurable as any combination of:
 - Up to 8 analog inputs, digital inputs, or digital outputs
- Programmable averaging filters:
 - Programmable sample size for averaging
 - Averaging with internal conversions
 - 20-bit resolution for average output
- Low-leakage multiplexer with channel sequencer:
 - Manual mode, on-the-fly mode, and auto-sequence mode
- Excellent AC and DC performance:
 - SNR: 91.9 dB, THD: –100 dB
 - Improved SNR with programmable averaging filters
 - INL: ± 1 LSB, 16-bit no missing codes
 - Internal calibration improves offset and drift
 - 250 kSPS sample rate with no latency
- Wide operating range:
 - ADC input range: 0 V to V_{REF} and $2 \times V_{REF}$
 - Analog supply: 3 V to 5.5 V
 - Digital supply: 1.65 V to 5.5 V
 - Temperature range: -40°C to $+125^{\circ}\text{C}$
- Enhanced-SPI digital interface:
 - High-speed, 60-MHz SPI

2 Applications

- [Optical modules](#)
- [Optical line cards](#)
- [Multiparameter patient monitors](#)

3 Description

The ADS7066 is a small, 16-bit, 8-channel, high-precision successive-approximation register (SAR) analog-to-digital converter (ADC). The ADS7066 has an integrated capless reference and a reference buffer that helps reduce the overall solution size by requiring fewer external components. The device family includes the ADS7067 (800 kSPS) and the ADS7066 (250 kSPS) speed variants.

The ADS7066 features built-in offset calibration for improved accuracy over wide operating conditions of the system. The programmable averaging filters enable higher resolution measurement. The eight channels of the ADS7066 can be individually configured as analog inputs, digital inputs, or digital outputs that simplify circuit design for mixed signal feedback and digital control.

The enhanced-SPI enables the ADS7066 in achieving high throughput at lower clock speeds, thereby simplifying the board layout and lowering system cost. The ADS7066 features a cyclic redundancy check (CRC) for data read and write operations and the power-up configuration.

Package Information

| PART NAME | PACKAGE ⁽¹⁾ | PACKAGE SIZE (NOM) ⁽²⁾ |
|-----------|------------------------|-----------------------------------|
| ADS7066 | YBH (DSBGA, 16) | 1.636 mm × 1.636 mm |
| | RTE (WQFN, 16) | 3.00 mm × 3.00 mm |

- (1) For all available packages, see the orderable addendum at the end of the data sheet.
- (2) The package size (length × width) is a nominal value and includes pins, where applicable.

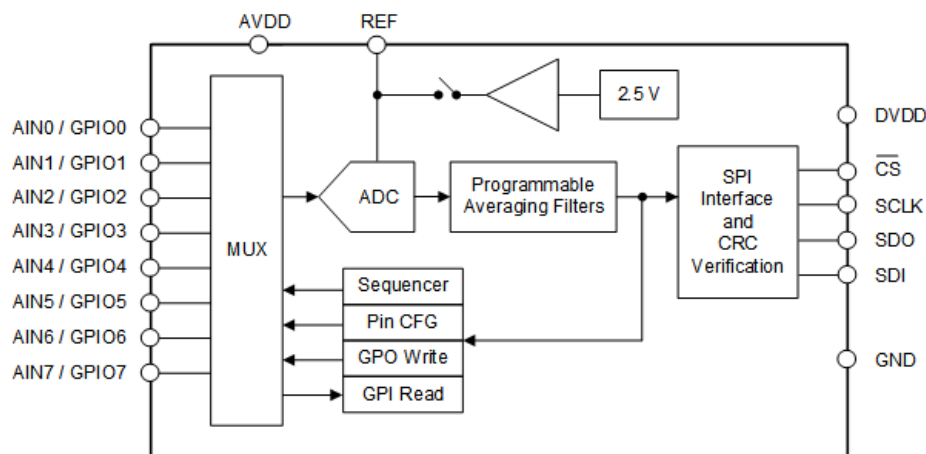

ADS7066 Block Diagram



Table of Contents

| | | | |
|--|----|--|----|
| 1 Features | 1 | 7.3 Feature Description..... | 15 |
| 2 Applications | 1 | 7.4 Device Functional Modes..... | 25 |
| 3 Description | 1 | 7.5 ADS7066 Registers..... | 28 |
| 4 Revision History | 2 | 8 Application and Implementation | 35 |
| 5 Pin Configuration and Functions | 3 | 8.1 Application Information..... | 35 |
| 6 Specifications | 5 | 8.2 Typical Application..... | 35 |
| 6.1 Absolute Maximum Ratings | 5 | 8.3 Power Supply Recommendations..... | 37 |
| 6.2 ESD Ratings | 5 | 8.4 Layout..... | 38 |
| 6.3 Recommended Operating Conditions | 5 | 9 Device and Documentation Support | 39 |
| 6.4 Thermal Information | 6 | 9.1 Device Support..... | 39 |
| 6.5 Electrical Characteristics | 7 | 9.2 Documentation Support..... | 39 |
| 6.6 Timing Requirements | 8 | 9.3 Receiving Notification of Documentation Updates..... | 39 |
| 6.7 Switching Characteristics | 8 | 9.4 Support Resources..... | 39 |
| 6.8 Timing Diagrams..... | 9 | 9.5 Trademarks..... | 39 |
| 6.9 Typical Characteristics..... | 10 | 9.6 Electrostatic Discharge Caution..... | 39 |
| 7 Detailed Description | 14 | 9.7 Glossary..... | 39 |
| 7.1 Overview..... | 14 | 10 Mechanical, Packaging, and Orderable Information | 39 |
| 7.2 Functional Block Diagram..... | 14 | | |

4 Revision History

NOTE: Page numbers for previous revisions may differ from page numbers in the current version.

| Changes from Revision B (May 2023) to Revision C (September 2023) | Page |
|---|-------------|
| • Changed document status of RTE (WQFN) package from <i>Advance Information</i> to <i>Production Data</i> | 1 |

| Changes from Revision A (June 2020) to Revision B (May 2023) | Page |
|---|-------------|
| • Updated the numbering format for tables, figures, and cross-references throughout the document..... | 1 |
| • Added RTE (WQFN) package to document as <i>Advance Information</i> | 1 |
| • Changed SNR from 86 dB to 91.9 dB in <i>Excellent AC and DC performance</i> bullet..... | 1 |
| • Deleted last <i>Features</i> bullet..... | 1 |
| • Deleted WCSP and space-constrained discussion from <i>Description</i> section..... | 1 |
| • Added RTE information to <i>Pin Configuration and Functions</i> section..... | 3 |
| • Added <i>PSRR vs Frequency</i> figure..... | 10 |
| • Added first sentence to <i>External Reference</i> section..... | 15 |
| • Deleted last paragraph from <i>Internal Reference</i> section..... | 15 |
| • Added reference to <i>Resolution-Boosting ADS7066 Using Programmable Averaging Filter</i> application report and changed title of <i>Averaged Output Data</i> figure..... | 17 |
| • Changed the <i>CRC on Data Interface</i> section..... | 17 |
| • Changed discussion of when status flags are not appended in <i>Status Flags</i> section | 20 |
| • Changed discussion of CRC comparison in <i>Output CRC (Device to Host)</i> section..... | 20 |
| • Deleted second paragraph from <i>Input CRC (Host to Device)</i> section..... | 20 |

5 Pin Configuration and Functions

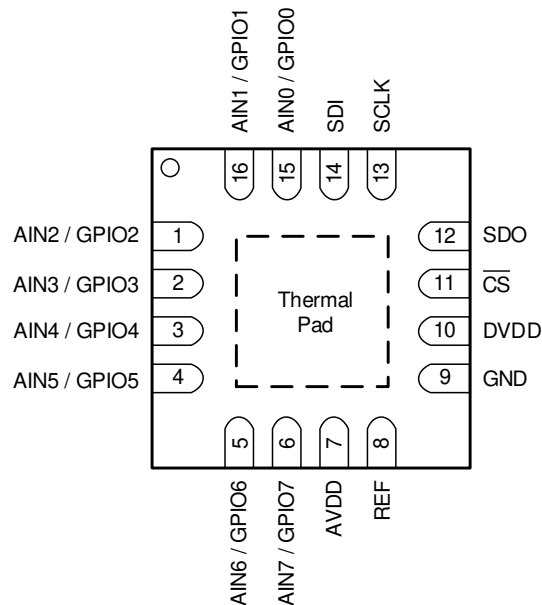

Figure 5-1. RTE Package, 16-Pin WQFN (Top View)

Table 5-1. Pin Functions: RTE Package

| PIN | | TYPE ⁽¹⁾ | DESCRIPTION |
|------------------------|-----|---------------------|---|
| NAME | RTE | | |
| AIN0/GPIO0 | 15 | AI, DI, DO | Channel 0; configurable as either an analog input (default) or general-purpose input/output (GPIO). |
| AIN1/GPIO1 | 16 | AI, DI, DO | Channel 1; configurable as either an analog input (default) or GPIO. |
| AIN2/GPIO2 | 1 | AI, DI, DO | Channel 2; configurable as either an analog input (default) or GPIO. |
| AIN3/GPIO3 | 2 | AI, DI, DO | Channel 3; configurable as either an analog input (default) or GPIO. |
| AIN4/GPIO4 | 3 | AI, DI, DO | Channel 4; configurable as either an analog input (default) or GPIO. |
| AIN5/GPIO5 | 4 | AI, DI, DO | Channel 5; configurable as either an analog input (default) or GPIO. |
| AIN6/GPIO6 | 5 | AI, DI, DO | Channel 6; configurable as either an analog input (default) or GPIO. |
| AIN7/GPIO7 | 6 | AI, DI, DO | Channel 7; configurable as either an analog input (default) or GPIO. |
| AVDD | 7 | P | Analog supply voltage. Connect a 1- μ F capacitor to GND. |
| $\overline{\text{CS}}$ | 11 | DI | Chip-select input pin; active low. The device takes control of the data bus when $\overline{\text{CS}}$ is low. The SDO pin goes to Hi-Z when $\overline{\text{CS}}$ is high. |
| DVDD | 10 | P | Digital I/O supply voltage. Connect a 1- μ F capacitor to GND. |
| GND | 9 | P | Ground for power supply, all analog and digital signals are referred to this pin. |
| REF | 8 | P | Internal reference buffer output; external reference input. Connect a 1- μ F capacitor to GND. |
| SCLK | 13 | DI | Clock input pin for the SPI interface. |
| SDI | 14 | DI | Serial data input pin for SPI interface. |
| SDO | 12 | DO | Serial data output pin for SPI interface. |
| Thermal Pad | Pad | P | Exposed thermal pad. Connect to ground. |

(1) AI = analog input, DI = digital input, DO = digital output, P = power supply.

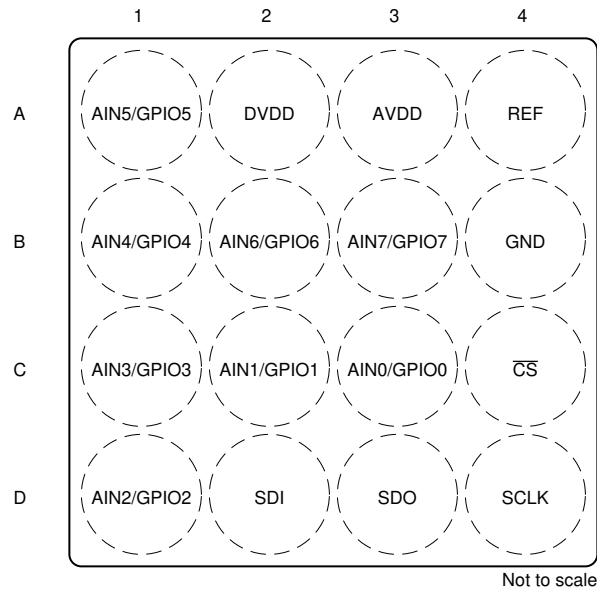

Figure 5-2. YBH Package, 16-Pin DSBGA (Top View)

Table 5-2. Pin Functions: YBH Package

| PIN | | TYPE ⁽¹⁾ | DESCRIPTION |
|-----|-----------------|---------------------|---|
| YBH | NAME | | |
| A1 | AIN5/GPIO5 | AI, DI, DO | Channel 5; configurable as either an analog input (default) or GPIO. |
| A2 | DVDD | P | Digital I/O supply voltage. Connect a 1-μF capacitor to GND. |
| A3 | AVDD | P | Analog supply voltage. Connect a 1-μF capacitor to GND. |
| A4 | REF | P | Internal reference buffer output; external reference input. Connect a 1-μF capacitor to GND. |
| B1 | AIN4/GPIO4 | AI, DI, DO | Channel 4; configurable as either an analog input (default) or GPIO. |
| B2 | AIN6/GPIO6 | AI, DI, DO | Channel 6; configurable as either an analog input (default) or GPIO. |
| B3 | AIN7/GPIO7 | AI, DI, DO | Channel 7; configurable as either an analog input (default) or GPIO. |
| B4 | GND | P | Ground for power supply, all analog and digital signals are referred to this pin. |
| C1 | AIN3/GPIO3 | AI, DI, DO | Channel 3; configurable as either an analog input (default) or GPIO. |
| C2 | AIN1/GPIO1 | AI, DI, DO | Channel 1; configurable as either an analog input (default) or GPIO. |
| C3 | AIN0/GPIO0 | AI, DI, DO | Channel 0; configurable as either an analog input (default) or general-purpose input/output (GPIO). |
| C4 | \overline{CS} | DI | Chip-select input pin; active low. The device takes control of the data bus when \overline{CS} is low. The SDO pin goes to Hi-Z when \overline{CS} is high. |
| D1 | AIN2/GPIO2 | AI, DI, DO | Channel 2; configurable as either an analog input (default) or GPIO. |
| D2 | SDI | DI | Serial data input pin for SPI interface. |
| D3 | SDO | DO | Serial data output pin for SPI interface. |
| D4 | SCLK | DI | Clock input pin for the SPI interface. |

(1) AI = analog input, DI = digital input, DO = digital output, P = power supply.

6 Specifications

6.1 Absolute Maximum Ratings

over operating ambient temperature range (unless otherwise noted)⁽¹⁾

| | MIN | MAX | UNIT |
|--|-----------|------------|------|
| DVDD to GND | -0.3 | 5.5 | V |
| AVDD to GND | -0.3 | 5.5 | V |
| AINx/GPIOx ⁽²⁾ to GND | GND - 0.3 | AVDD + 0.3 | V |
| REF to GND | GND - 0.3 | AVDD + 0.3 | V |
| Digital inputs (CS, SDI, SCLK) to GND | GND - 0.3 | 5.5 | V |
| Input current to any pin except supply pins ⁽³⁾ | -10 | 10 | mA |
| Junction temperature, T _J | -40 | 150 | °C |
| Storage temperature, T _{stg} | -60 | 150 | °C |

- (1) Stresses beyond those listed under *Absolute Maximum Rating* may cause permanent damage to the device. These are stress ratings only, which do not imply functional operation of the device at these or any other conditions beyond those indicated under *Recommended Operating Condition*. Exposure to absolute-maximum-rated conditions for extended periods may affect device reliability.
- (2) AINx/GPIOx refers to AIN0/GPIO0, AIN1/GPIO1, AIN2/GPIO2, AIN3/GPIO3, AIN4/GPIO4, AIN5/GPIO5, AIN6/GPIO6, and AIN7/GPIO7 pins.
- (3) Pin current must be limited to 10 mA or less.

6.2 ESD Ratings

| | | VALUE | UNIT |
|--------------------|-------------------------|--|-------|
| V _(ESD) | Electrostatic discharge | Human body model (HBM), per ANSI/ESDA/ JEDEC JS-001, all pins ⁽¹⁾ | ±2000 |
| | | Charged device model (CDM), per JEDEC specification JESD22-C101, all pins ⁽²⁾ | ±500 |

- (1) JEDEC document JEP155 states that 500-V HBM allows safe manufacturing with a standard ESD control process.
- (2) JEDEC document JEP157 states that 250-V CDM allows safe manufacturing with a standard ESD control process.

6.3 Recommended Operating Conditions

over operating free-air temperature range (unless otherwise noted)

| PARAMETER | | TEST CONDITIONS | MIN | TYP | MAX | UNIT |
|--------------------------|------------------------------|----------------------------|------|-----|----------------------|------|
| POWER SUPPLY | | | | | | |
| AVDD | Analog power supply | AVDD to GND | 3 | 3.3 | 5.5 | V |
| DVDD | Digital power supply | DVDD to GND | 1.65 | 3.3 | 5.5 | V |
| REFERENCE VOLTAGE | | | | | | |
| V _{REF} | Reference voltage to the ADC | Internal reference | 2.5 | | AVDD | V |
| | | External reference | 2.4 | | | |
| ANALOG INPUTS | | | | | | |
| FSR | Full-scale input range | RANGE = 0b | 0 | | V _{REF} | V |
| | | RANGE = 1b | 0 | | 2 x V _{REF} | |
| V _{IN} | Absolute input voltage | AINx ⁽¹⁾ to GND | -0.1 | | AVDD + 0.1 | V |
| TEMPERATURE RANGE | | | | | | |
| T _A | Ambient temperature | | -40 | 25 | 125 | °C |

- (1) AINx refers to analog inputs AIN0, AIN1, AIN2, AIN3, AIN4, AIN5, AIN6, and AIN7.

6.4 Thermal Information

| THERMAL METRIC ⁽¹⁾ | | ADS7066 | UNIT |
|-------------------------------|--|------------|------|
| | | YBH (WCSP) | |
| | | 16 PINS | |
| $R_{\theta JA}$ | Junction-to-ambient thermal resistance | 80.2 | °C/W |
| $R_{\theta JC(top)}$ | Junction-to-case (top) thermal resistance | 0.4 | °C/W |
| $R_{\theta JB}$ | Junction-to-board thermal resistance | 18.8 | °C/W |
| Ψ_{JT} | Junction-to-top characterization parameter | 0.2 | °C/W |
| Ψ_{JB} | Junction-to-board characterization parameter | 18.8 | °C/W |

- (1) For more information about traditional and new thermal metrics, see the [Semiconductor and IC Package Thermal Metrics](#) application report.

6.5 Electrical Characteristics

at AVDD = 3 V to 5.5 V, DVDD = 1.65 V to 5.5 V, VREF = 2.5 V (internal), and maximum throughput (unless otherwise noted); minimum and maximum values at TA = -40°C to +125°C; typical values at TA = 25°C.

| PARAMETER | | TEST CONDITIONS | MIN | TYP | MAX | UNIT |
|------------------------|--|--|----------|----------|-------|--------|
| ANALOG INPUTS | | | | | | |
| CIN | Input capacitance | ADC and MUX capacitance | | 30 | | pF |
| DC PERFORMANCE | | | | | | |
| | Resolution | No missing codes | | 16 | | Bits |
| DNL | Differential nonlinearity | | -0.75 | ±0.4 | 0.75 | LSB |
| INL | Integral nonlinearity | | -4 | ±1 | 4 | LSB |
| V(OS) | Input offset error | Post offset calibration, OSR[2:0] = 7 | -7 | ±0.5 | 7 | LSB |
| dV(OS)/dT | Input offset thermal drift | Post offset calibration, OSR[2:0] = 7 | | ±0.6 | | ppm/°C |
| | Offset error match | OSR[2:0] = 7 | -2.75 | 0.5 | 2.75 | LSB |
| GE | Gain error ⁽¹⁾ | External VREF = 2.5 V, OSR[2:0] = 7 | -0.05 | ±0.01 | 0.05 | %FSR |
| dGE/dT | Gain error thermal drift | External VREF = 2.5 V, OSR[2:0] = 7 | | ±0.5 | | ppm/°C |
| | Gain error match | OSR[2:0] = 7 | -0.005 | ±0.001 | 0.005 | %FSR |
| AC PERFORMANCE | | | | | | |
| SINAD | Signal-to-noise + distortion ratio | fIN = 2 kHz, VREF = 2.5V (internal) | 84.3 | 86.5 | | dB |
| | | fIN = 2 kHz, VREF = 5 V, AVDD = 5 V | 88.75 | 91 | | |
| SNR | Signal-to-noise ratio | fIN = 2 kHz, VREF = 2.5V (internal) | 84.5 | 86.8 | | dB |
| | | fIN = 2 kHz, VREF = 5 V, AVDD = 5 V | 90 | 91.9 | | |
| THD | Total harmonic distortion | fIN = 2 kHz | | -100 | | dB |
| SFDR | Spurious-free dynamic range | fIN = 2 kHz | | 101 | | dB |
| | Isolation crosstalk | fIN = 10 kHz | | -110 | | dB |
| REFERENCE | | | | | | |
| VREF | Internal reference output voltage ⁽³⁾ | at TA= 25°C | 2.497 | 2.5 | 2.503 | V |
| dVREF/dT | Internal reference voltage temperature drift | | | 6 | 19 | ppm/°C |
| CREF | Decoupling capacitor at REF pin | | 1 | | 10 | µF |
| DIGITAL INPUTS | | | | | | |
| VIL | Input low logic level | For CS, SCLK and SDI pins | -0.3 | 0.3 DVDD | | V |
| | | For GPIOX ⁽²⁾ pins | -0.3 | 0.3 AVDD | | |
| VIH | Input high logic level | For CS, SCLK and SDI pins | 0.7 DVDD | DVDD | | V |
| | | For GPIOX pins | 0.7 AVDD | AVDD | | |
| DIGITAL OUTPUTS | | | | | | |
| VOL | Output low logic level | For SDO pin, IOL = 500 µA sink | 0 | 0.2 DVDD | | V |
| | | For GPIOX ⁽²⁾ pins, IOL = 500 µA sink | 0 | 0.2 AVDD | | |
| VOH | Output high logic level | For SDO pin, IOH = 500 µA source | 0.8 DVDD | DVDD | | V |
| | | For GPIOX ⁽²⁾ pins, IOH = 500 µA source | 0.8 AVDD | AVDD | | |
| POWER SUPPLY | | | | | | |
| IAVDD | Analog supply current | AVDD = 3.3 V, external reference | | 0.7 | 0.91 | mA |
| | | AVDD = 3.3 V, internal reference | | 1.2 | 1.56 | mA |
| | | No conversion, external reference | | 250 | | µA |
| | | No conversion, internal reference | | 800 | | µA |

(1) These specifications include full temperature range variation but not the error contribution from internal reference.

(2) GPIOX refers to GPIO0, GPIO1, GPIO2, GPIO3, GPIO4, GPIO5, GPIO6, and GPIO7 pins.

(3) Does not include the variation in voltage resulting from solder shift effects.

6.6 Timing Requirements

at AVDD = 3 V to 5 V, DVDD = 1.65 V to 5.5 V, and maximum throughput (unless otherwise noted); minimum and maximum values at $T_A = -40^\circ\text{C}$ to $+125^\circ\text{C}$; typical values at $T_A = 25^\circ\text{C}$.

| | | MIN | MAX | UNIT |
|------------------------------|---|----------------------|------|------------------|
| CONVERSION CYCLE | | | | |
| f_{CYCLE} | Sampling frequency | | 250 | kSPS |
| t_{CYCLE} | ADC cycle-time period | $1/f_{\text{CYCLE}}$ | | s |
| t_{QUIET} | Quiet acquisition time | 20 | | ns |
| t_{ACQ} | Acquisition time | Acquisition time | 800 | ns |
| $t_{\text{WH_CSZ}}$ | Pulse duration: $\overline{\text{CS}}$ high | 220 | | ns |
| $t_{\text{WL_CSZ}}$ | Pulse duration: $\overline{\text{CS}}$ low | 210 | | ns |
| SPI INTERFACE TIMINGS | | | | |
| f_{CLK} | Maximum SCLK frequency | | 60 | MHz |
| t_{CLK} | Minimum SCLK time period | 16.67 | | ns |
| $t_{\text{PH_CK}}$ | SCLK high time | 0.45 | 0.55 | t_{CLK} |
| $t_{\text{PL_CK}}$ | SCLK low time | 0.45 | 0.55 | t_{CLK} |
| $t_{\text{SU_CSCK}}$ | Setup time: $\overline{\text{CS}}$ falling to the first SCLK capture edge | 15 | | ns |
| $t_{\text{SU_CKDI}}$ | Setup time: SDI data valid to the SCLK capture edge | 6.4 | | ns |
| $t_{\text{HT_CKDI}}$ | Hold time: SCLK capture edge to data valid on SDI | 4 | | ns |
| $t_{\text{D_CKCS}}$ | Delay time: last SCLK falling to $\overline{\text{CS}}$ rising | 0.8 | | ns |

6.7 Switching Characteristics

at AVDD = 3 V to 5 V, DVDD = 1.65 V to 5.5 V, and maximum throughput (unless otherwise noted); minimum and maximum values at $T_A = -40^\circ\text{C}$ to $+125^\circ\text{C}$; typical values at $T_A = 25^\circ\text{C}$.

| PARAMETER | | TEST CONDITIONS | MIN | MAX | UNIT |
|------------------------------|--|-----------------|-----|------|------|
| CONVERSION CYCLE | | | | | |
| t_{CONV} | ADC conversion time | | | 3200 | ns |
| RESET | | | | | |
| t_{PU} | Power-up time for device | AVDD \geq 3 V | | 5 | ms |
| t_{RST} | Delay time; RST bit = 1b to device reset complete ⁽¹⁾ | | | 5 | ms |
| SPI INTERFACE TIMINGS | | | | | |
| $t_{\text{DEN_CSDO}}$ | Delay time: $\overline{\text{CS}}$ falling to data enable | | | 22 | ns |
| $t_{\text{DZ_CSDO}}$ | Delay time: $\overline{\text{CS}}$ rising to SDO going Hi-Z | | | 50 | ns |
| $t_{\text{D_CKDO}}$ | Delay time: SCLK launch edge to (next) data valid on SDO | | | 16 | ns |

(1) RST bit is automatically reset to 0b after t_{RST} .

6.8 Timing Diagrams

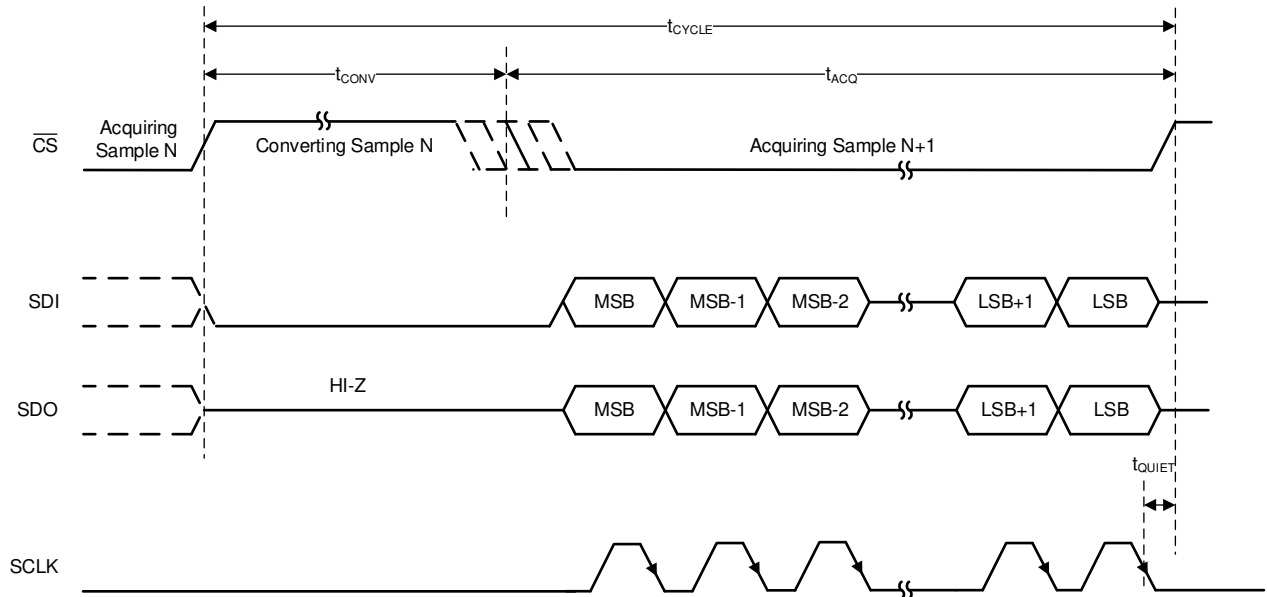

Figure 6-1. Conversion Cycle Timing

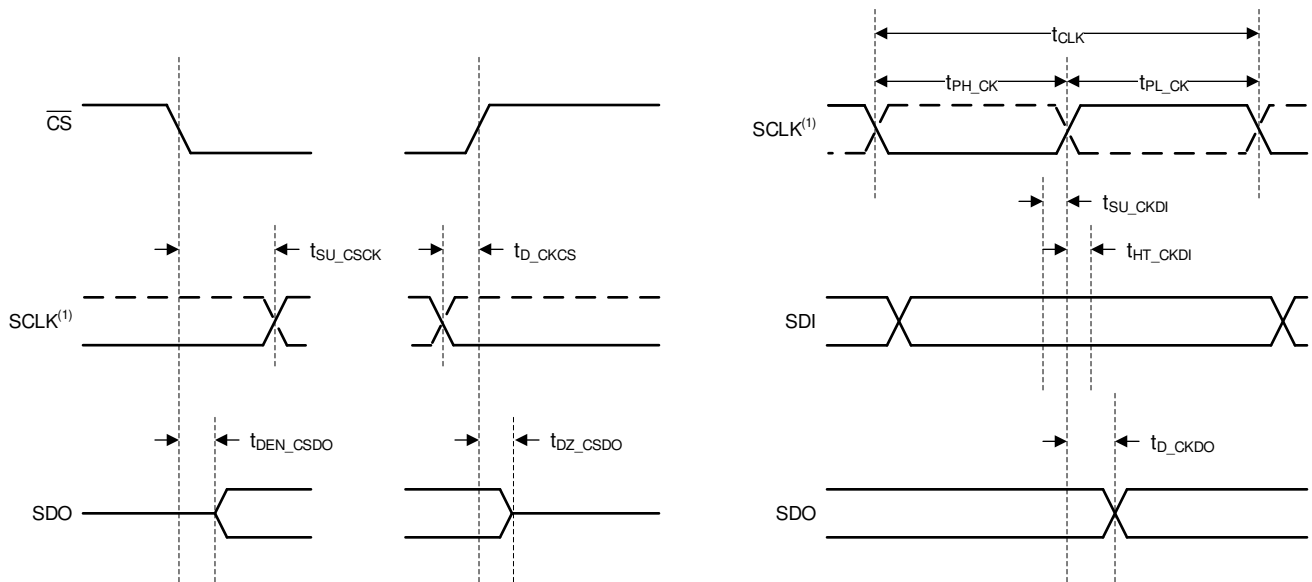
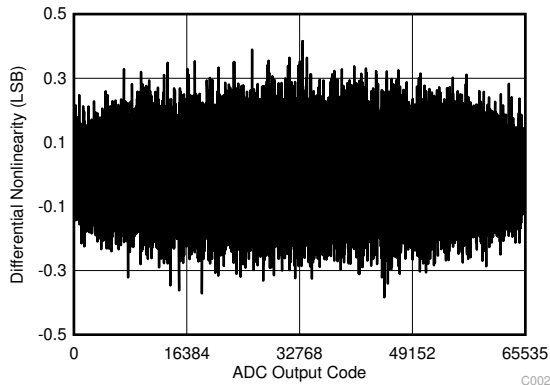

Figure 6-2. SPI Interface Timing

6.9 Typical Characteristics

at $T_A = 25^\circ\text{C}$, $AVDD = 5\text{ V}$, $DVDD = 1.65\text{ V to }5.5\text{ V}$, and maximum throughput (unless otherwise noted)



Typical DNL = $\pm 0.4\text{ LSB}$

Figure 6-3. Typical DNL

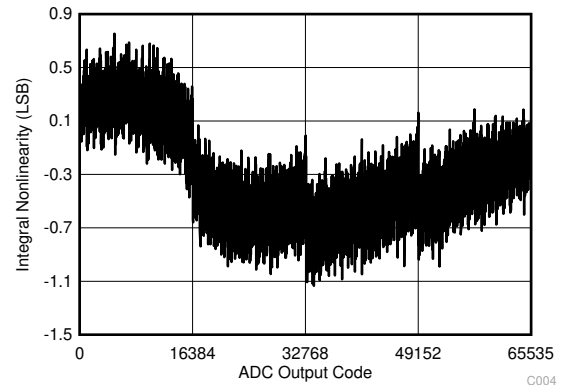

Typical INL = $\pm 1\text{ LSB}$

Figure 6-4. Typical INL

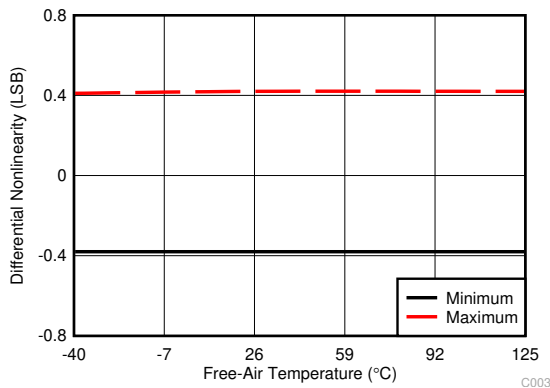

Figure 6-5. DNL vs Temperature

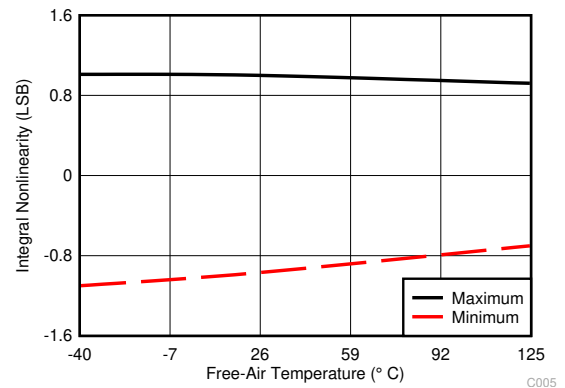

Figure 6-6. INL vs Temperature

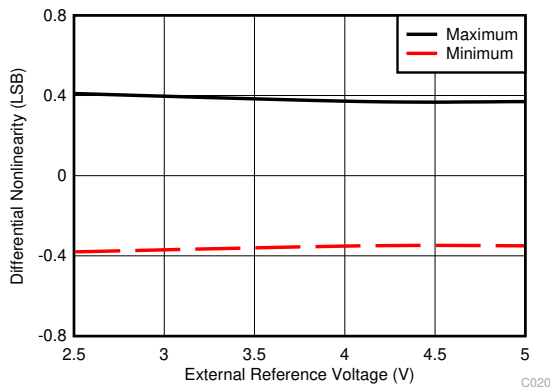

Figure 6-7. DNL vs External Reference Voltage

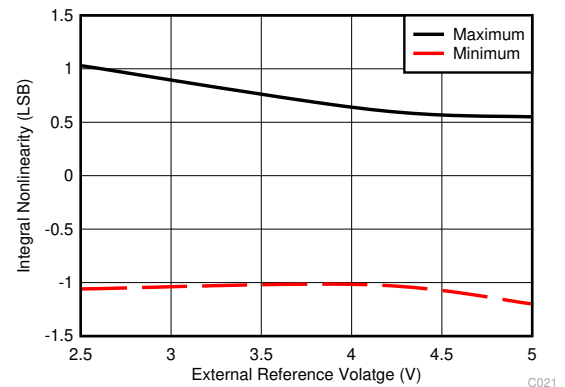

Figure 6-8. INL vs External Reference Voltage

6.9 Typical Characteristics (continued)

at $T_A = 25^\circ\text{C}$, $AVDD = 5\text{ V}$, $DVDD = 1.65\text{ V to }5.5\text{ V}$, and maximum throughput (unless otherwise noted)

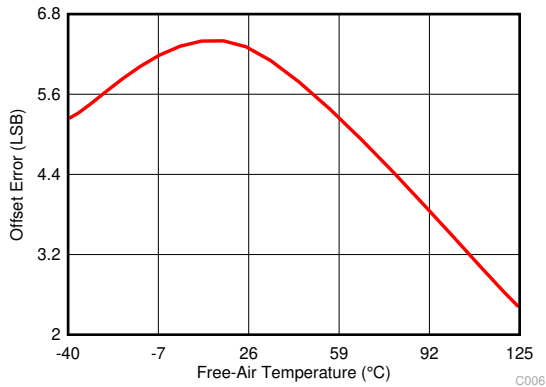

Figure 6-9. Offset Error vs Temperature

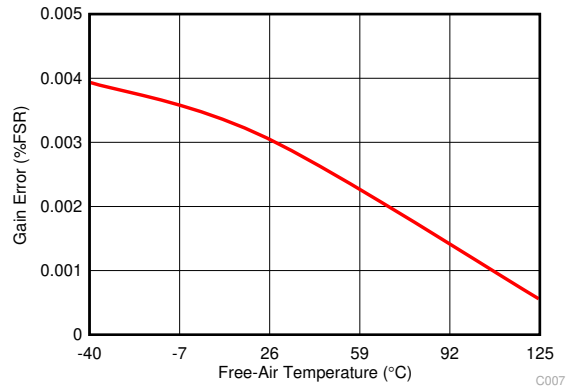

Figure 6-10. Gain Error vs Temperature

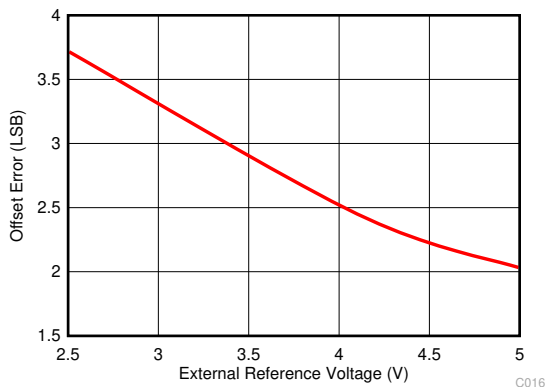

Figure 6-11. Offset Error vs External Reference Voltage

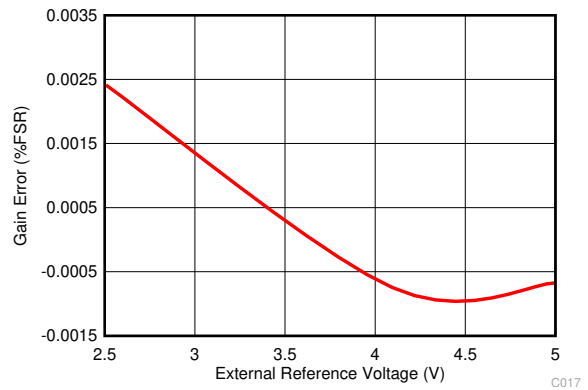

Figure 6-12. Gain Error vs External Reference Voltage

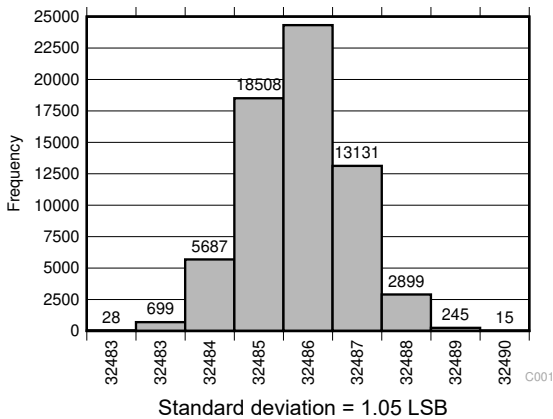

Figure 6-13. DC Input Histogram

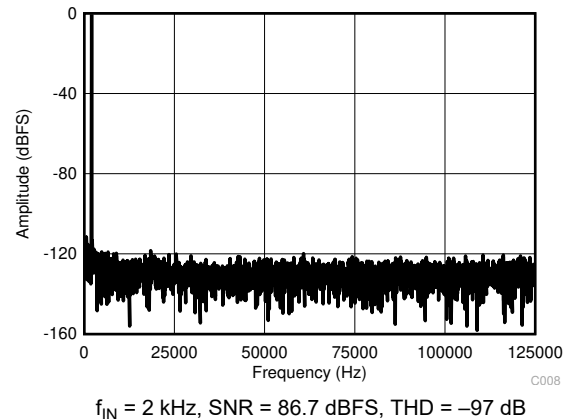

Figure 6-14. Typical FFT

6.9 Typical Characteristics (continued)

at $T_A = 25^\circ\text{C}$, $AVDD = 5\text{ V}$, $DVDD = 1.65\text{ V to }5.5\text{ V}$, and maximum throughput (unless otherwise noted)

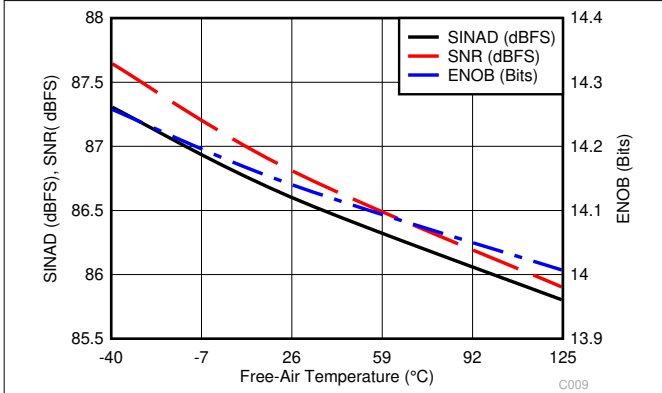

Figure 6-15. Noise Performance vs Temperature

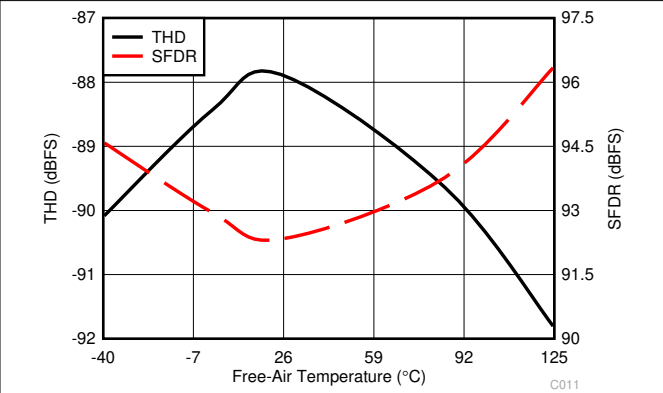

Figure 6-16. Distortion Performance vs Temperature

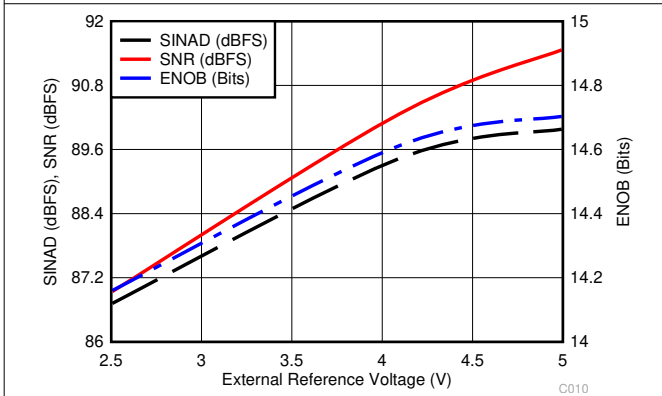

Figure 6-17. Noise Performance vs External Reference Voltage

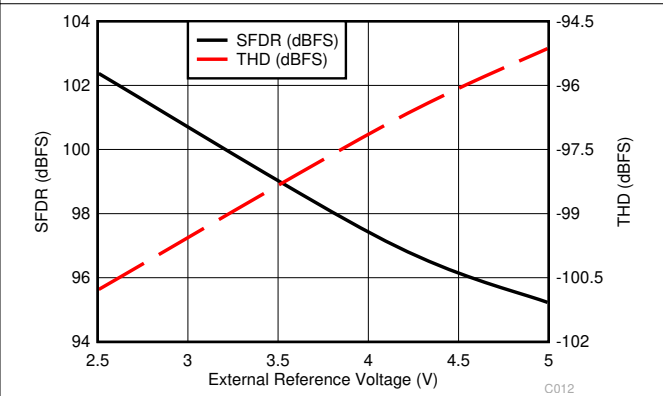

Figure 6-18. Distortion Performance vs External Reference Voltage

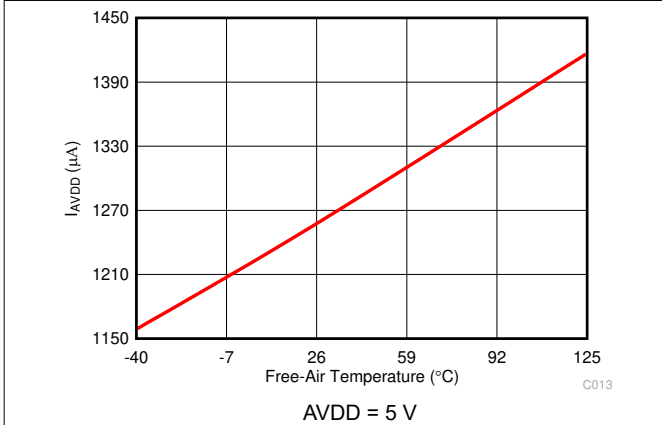

Figure 6-19. Analog Supply Current vs Temperature

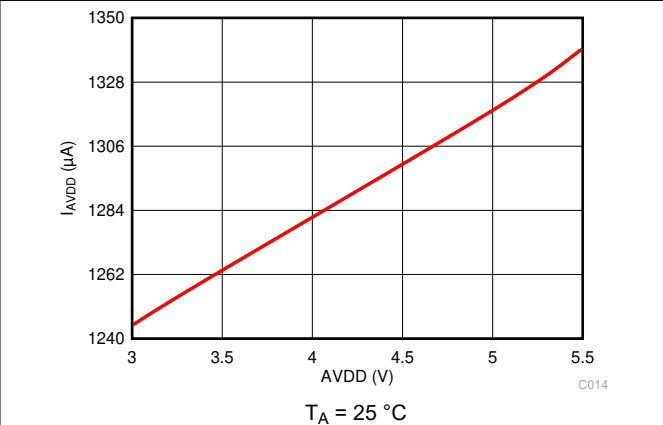

Figure 6-20. Analog Supply Current vs AVDD

6.9 Typical Characteristics (continued)

at $T_A = 25^\circ\text{C}$, $AVDD = 5\text{ V}$, $DVDD = 1.65\text{ V to }5.5\text{ V}$, and maximum throughput (unless otherwise noted)

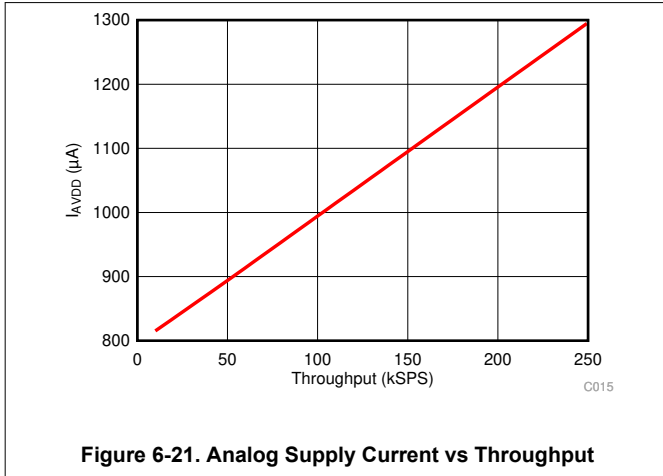

Figure 6-21. Analog Supply Current vs Throughput

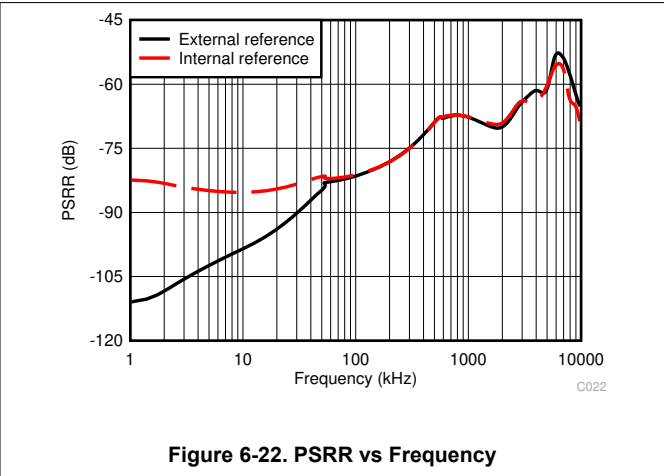

Figure 6-22. PSRR vs Frequency

7 Detailed Description

7.1 Overview

The ADS7066 is a 16-bit, successive approximation register (SAR) analog-to-digital converter (ADC) with an analog multiplexer. This device integrates a reference, reference buffer, low-dropout regulator (LDO), and features high performance at full throughput and low-power consumption.

The ADS7066 supports unipolar, single-ended analog input signals. The internal reference generates a low-drift, buffered, 2.5-V reference output. The device uses an internal clock to perform conversions. At the end of the conversion process, the device enters an acquisition phase.

7.2 Functional Block Diagram

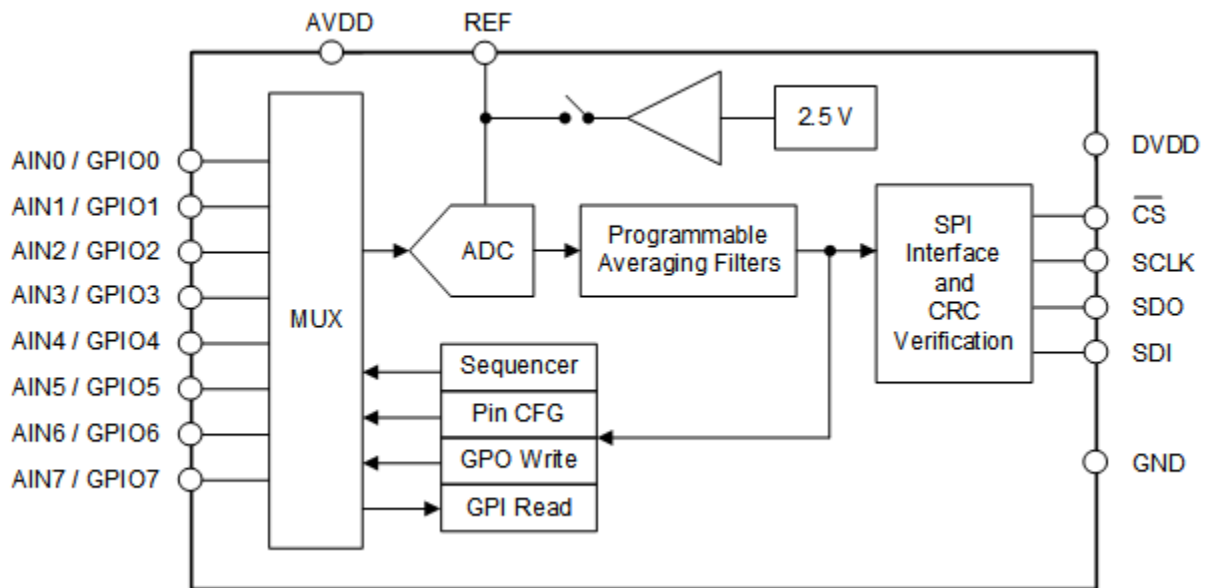

7.3 Feature Description

7.3.1 Analog Input and Multiplexer

The eight channels of the multiplexer can be independently configured as ADC inputs or general-purpose inputs/outputs (GPIOs). As shown in [Figure 7-1](#), each input pin has ESD protection diodes to AVDD and GND. On power-up or after device reset, all eight channels of the multiplexer are configured as analog inputs.

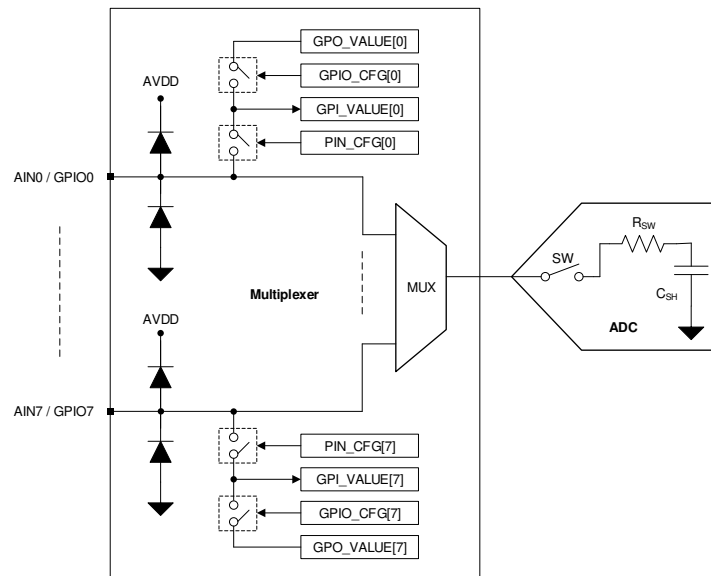

Figure 7-1. Analog Inputs, GPIOs, and ADC Connections

[Figure 7-1](#) shows an equivalent circuit for the pins configured as analog inputs. The ADC sampling switch is represented by an ideal switch (SW) in series with a resistor (R_{SW} , typically 150 Ω) and a sampling capacitor (C_{SH} , typically 30 pF). During acquisition, the SW switch is closed to allow the signal on the selected analog input channel to charge the internal sampling capacitor. During conversion, the SW switch is opened to disconnect the analog input channel from the sampling capacitor.

The multiplexer channels can be configured as GPIOs in the PIN_CFG register. On power-up, all channels of the multiplexer are configured as analog inputs. The direction of a GPIO, input or output, can be set in the GPIO_CFG register. The logic level of channels configured as digital inputs can be read from the GPI_VALUE register. The digital outputs can be accessed by writing to the GPO_VALUE register. The digital outputs can be configured as open-drain or push-pull in the GPO_DRIVE_CFG register.

7.3.2 Reference

The ADS7066 has a precision, low-drift voltage reference internal to the device.

7.3.2.1 External Reference

External reference is the default configuration on power-up or after device reset. An external reference voltage source can be connected to the REF pin with an appropriate decoupling capacitor placed between the REF and GND pins. Best SNR is achieved with a 5-V external reference because the internal reference is limited to 2.5 V. For improved thermal drift performance, a reference from the REF60xx family ([REF6025](#), [REF6030](#), [REF6033](#), [REF6041](#), [REF6045](#), or [REF6050](#)) is recommended.

7.3.2.2 Internal Reference

The device features an internal reference source with a nominal output value of 2.5 V. On power-up, the internal reference is disabled by default. To enable the internal reference, set EN_REF = 1b in the GENERAL_CFG register. A minimum 1- μ F decoupling capacitor is recommended to be placed between the REF and GND pins. The capacitor must be placed as close to the REF pin as possible. The REF pin has ESD protection diodes connected to the AVDD and GND pins.

7.3.3 ADC Transfer Function

The ADC output is in straight binary format. The full-scale input range (FSR) of the ADC is determined by the RANGE bit. On power-up, the FSR is 0 V to V_{REF} . When using the $2 \times V_{REF}$ mode (RANGE = 1b), the ADC can measure analog inputs up to two times the voltage reference. Equation 1 can be used to compute the ADC resolution:

$$1 \text{ LSB} = \text{FSR} / 2^N \tag{1}$$

where:

- FSR = Full-scale input range of the ADC
- N = 16

Figure 7-2 and Table 7-1 show the ideal transfer characteristics for this device.

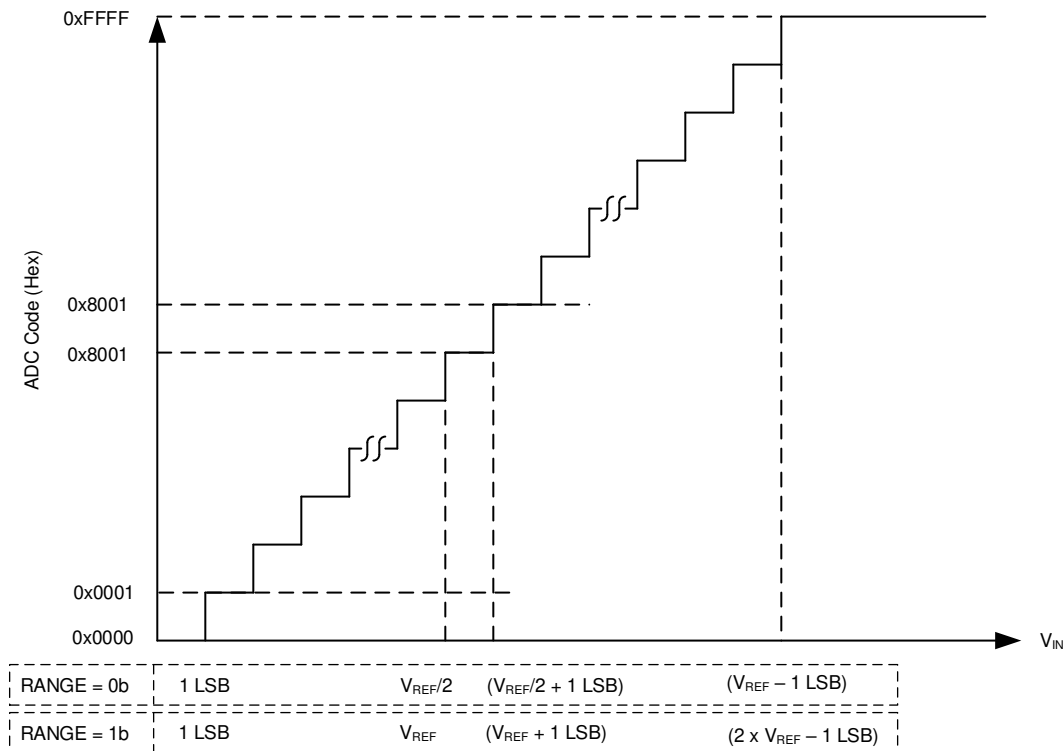

Figure 7-2. Ideal Transfer Characteristics

Table 7-1. Transfer Characteristics

| INPUT VOLTAGE | | CODE | IDEAL OUTPUT CODE |
|---|---|--------------------|-------------------|
| RANGE = 0b | RANGE = 1b | | |
| $\leq 1 \text{ LSB}$ | $\leq 1 \text{ LSB}$ | Zero | 0000 |
| 1 LSB to 2 LSBs | 1 LSB to 2 LSBs | Zero + 1 | 0001 |
| $(V_{REF} / 2)$ to $(V_{REF} / 2) + 1 \text{ LSB}$ | V_{REF} to $V_{REF} + 1 \text{ LSB}$ | Mid-scale code | 8000 |
| $(V_{REF} / 2) + 1 \text{ LSB}$ to $(V_{REF} / 2) + 2 \text{ LSBs}$ | $V_{REF} + 1 \text{ LSB}$ to $V_{REF} + 2 \text{ LSBs}$ | Mid-scale code + 1 | 8001 |
| $\geq V_{REF} - 1 \text{ LSB}$ | $\geq 2 \times V_{REF} - 1 \text{ LSB}$ | Full-scale code | FFFF |

7.3.4 ADC Offset Calibration

The variation in ADC offset error resulting from changes in temperature or reference voltage can be calibrated by setting the CAL bit in the GENERAL_CFG register. The CAL bit is reset to 0 after calibration. The host can poll the CAL bit to check the ADC offset calibration completion status.

7.3.5 Programmable Averaging Filters

The ADS7066 features a programmable averaging filter that can be used to average analog input samples to output a higher resolution measurement. The averaging filter can be enabled by programming the OSR[2:0] bits in the OSR_CFG register to the averaging factor desired. The averaging configuration is common to all analog input channels. As shown in Figure 7-3, the output of the averaging filter is 20 bits long. In manual mode and auto-sequence mode of conversion, only the first conversion for the selected analog input channel must be initiated by the host, as shown in Figure 7-3; any remaining conversions are generated internally. The time (t_{AVG}) required to complete the averaging operation is determined by the sampling speed and number of samples to be averaged; see the [Oscillator and Timing Control](#) section for more details. After completion, the averaged 20-bit result, as shown in Figure 7-3, can be read-out. For information on the programmable averaging filters and performance results see the [Resolution-Boosting ADS7066 Using Programmable Averaging Filter application report](#).

In autonomous mode of operation, samples from analog input channels that are enabled in the AUTO_SEQ_CH_SEL register are averaged sequentially.

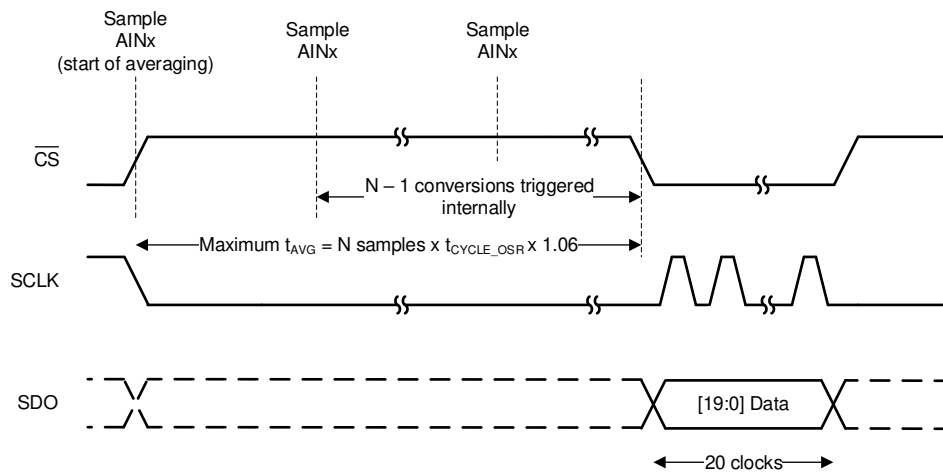

Figure 7-3. Averaged Output Data

7.3.6 CRC on Data Interface

The cyclic redundancy check (CRC) is an error checking code that detects communication errors to and from the host. CRC is the division remainder of the data payload bytes by a fixed polynomial. The data payload is two or three bytes, depending on the output data format; see the [Output Data Format](#) section for details on output data format. The CRC mode is optional and is enabled by the CRC_EN bit in the GENERAL_CFG register.

The CRC data byte is the 8-bit remainder of the bitwise exclusive-OR (XOR) operation of the argument by a CRC polynomial. The CRC polynomial is based on the CRC-8-CCITT: $X^8 + X^2 + X^1 + 1$. The nine binary polynomial coefficients are: 10000111. The CRC calculation is preset with 1 data values. For more details about the CRC implementation and for a software example, see the [Implementation of CRC for ADS7066 application report](#).

The host must compute and append the appropriate CRC to the command string in the same SPI frame (see the [Register Read/Write Operation](#) section). The ADC also computes the expected CRC corresponding to the payload received from the host and compares the calculated CRC code to the CRC received from the host. The CRC received from the host and the CRC calculated by the ADC on the received payload are compared to check for an exact match.

- If the calculated CRC and received CRC match then the data payload received from the host is valid.
- If the calculated CRC and received CRC do not match then the data payload received from the host is not valid and the command does not execute. The CRCERR_IN flag is set to 1b. ADC conversion data read and register read processes, with a valid CRC from the host, are still supported. The error condition can be detected, as listed in [Table 7-2](#), by either status flags or by a register read. Further register writes to the device are blocked until the CRCERR_IN flag is cleared to 0b. Register write operations, with a valid CRC from the host, to the SYSTEM_STATUS (address = 0x00) and GENERAL_CFG (address = 0x01) registers are still supported.

Table 7-2. Configuring Notifications When a CRC Error is Detected

| CRC ERROR NOTIFICATION | CONFIGURATION | DESCRIPTION |
|------------------------|---------------------|--|
| Status flags | APPEND_STATUS = 10b | 4-bit status flags, containing the CRCERR_IN bit appended to the ADC data; see the Output Data Format section for details. |
| Register read | — | Read the CRCERR_IN bit to check if a CRC error was detected. |

For a conversion data read or register data read, the ADC responds with a CRC that is computed over the requested data payload bytes. The response data payload is one, two, or three bytes depending on the data operation (see the [Output CRC \(Device to Host\)](#) section).

7.3.7 Oscillator and Timing Control

The device uses an internal oscillator for conversion. When using the averaging module, the host initiates the first conversion and subsequent conversions are generated internally by the device. When the device generates the start of a conversion, the sampling rate can be controlled as described in [Table 7-3](#) by the OSC_SEL and CLK_DIV[3:0] register fields.

The conversion time of the device, given by t_{CONV} in the *Switching Characteristics* table in the [Specifications](#) section, is independent of the OSC_SEL and CLK_DIV[3:0] configuration.

Table 7-3. Configuring the Sampling Rate for Internal Conversion Start Control

| CLK_DIV[3:0] | OSC_SEL = 0 | | OSC_SEL = 1 | |
|--------------|---|---|---|---|
| | SAMPLING FREQUENCY, f_{CYCLE_OSR} (kSPS) | CYCLE TIME, t_{CYCLE_OSR} (μ S) | SAMPLING FREQUENCY, f_{CYCLE_OSR} (kSPS) | CYCLE TIME, t_{CYCLE_OSR} (μ S) |
| 0000b | Reserved. Do not use. | Reserved. Do not use. | 31.25 | 32 |
| 0001b | Reserved. Do not use. | Reserved. Do not use. | 20.83 | 48 |
| 0010b | Reserved. Do not use. | Reserved. Do not use. | 15.63 | 64 |
| 0011b | Reserved. Do not use. | Reserved. Do not use. | 10.42 | 96 |
| 0100b | 250 | 4 | 7.81 | 128 |
| 0101b | 166.7 | 6 | 5.21 | 192 |
| 0110b | 125 | 8 | 3.91 | 256 |
| 0111b | 83 | 12 | 2.60 | 384 |
| 1000b | 62.5 | 16 | 1.95 | 512 |
| 1001b | 41.7 | 24 | 1.3 | 768 |
| 1010b | 31.3 | 32 | 0.98 | 1024 |
| 1011b | 20.8 | 48 | 0.65 | 1536 |
| 1100b | 15.6 | 64 | 0.49 | 2048 |
| 1101b | 10.4 | 96 | 0.33 | 3072 |

7.3.8 Diagnostic Modes

The ADS7066 features a programmable test voltage generation circuit that can be used for ADC diagnostics.

7.3.8.1 Bit-Walk Test Mode

To enable write access to the configuration registers for diagnostics, write 0x96 in the DIAGNOSTICS_KEY register. To enable bit-walk test mode, configure BITWALK_EN = 1b. In the bit-walk test mode (see [Figure 7-1](#)), the sampling switch (SW) remains open and the test voltage is applied on the sampling capacitor (C_{SH}) during the acquisition phase of the ADC. In diagnostic mode, the conversion process of the ADC remains the same as normal device operation. The ADC starts the conversion phase on the rising edge of \overline{CS} and outputs the code corresponding to the sampled test voltage. The output code of the ADC is expected to be proportional to the test voltage, as shown in [Equation 2](#), after adjusting for DC errors (such as INL, gain error, offset error, and thermal drift of offset and gain errors).

$$\text{Output code} = \left(\frac{\text{Test voltage}}{V_{\text{REF}}} \times 2^{16} \right) \pm \text{TUE} \quad (2)$$

where

- TUE = Total unadjusted error, given by the root sum square of the offset error, gain error, and INL

The test voltage is generated by a DAC configured by the BIT_SAMPLE_MSB and BIT_SAMPLE_LSB registers. Because the test voltage is derived from the ADC reference, as given by [Equation 3](#), this diagnostic mode is not sensitive to variations in reference voltage.

$$\text{Test voltage} = \frac{V_{\text{REF}}}{\text{BIT_SAMPLE}[15:0]} \pm \text{TUE} \quad (3)$$

To resume conversion of the ADC input signal, configure BITWALK_EN = 0b.

7.3.8.2 Fixed Voltage Test Mode

For diagnostics, the ADS7066 features a fixed 1.8 V (typical) test voltage which can be internally connected to AIN6. To connect AIN6 to the internal test voltage, set VTEST_EN = 1b. When using the fixed voltage test mode, AIN6 pin must be left floating and should not be connected to any external circuit.

If bit-walk test mode is enabled (that is, BITWALK_EN = 1b), enabling the fixed voltage test mode will connect AIN6 to the test voltage but the conversion result would be according to bit-walk test mode configuration.

7.3.9 Output Data Format

[Figure 7-4](#) illustrates that the output data payload consists of a combination of the conversion result, data bits from averaging filters, status flags, and channel ID. The conversion result is MSB aligned. If averaging is enabled, the output data from the ADC are 20 bits long, otherwise the data are 16 bits long. Optionally, the 4-bit channel ID or status flags can be appended at the end of the output data by configuring the APPEND_STATUS[1:0] fields.

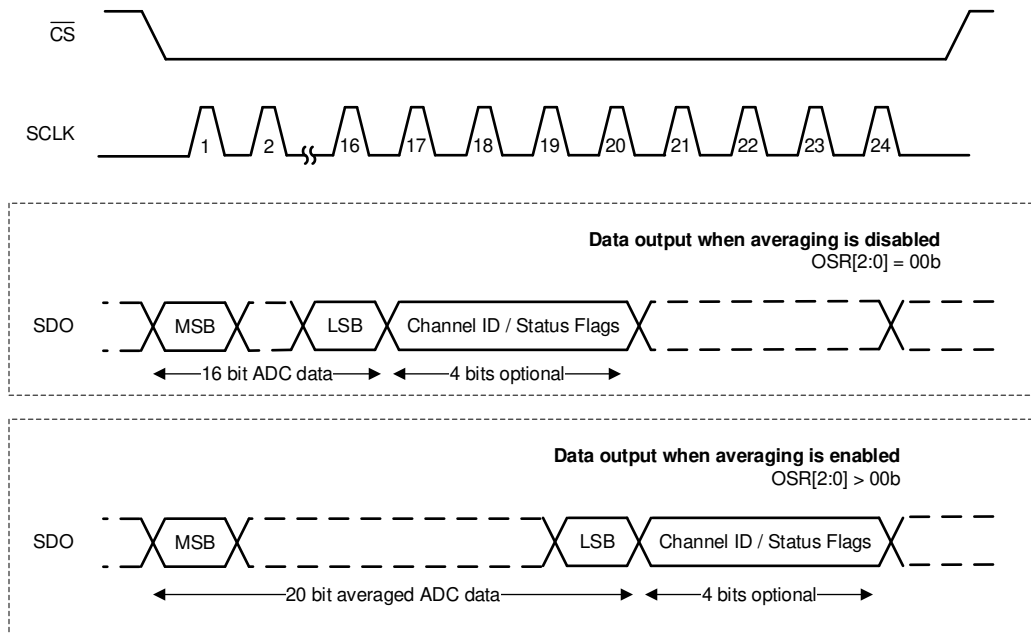

Figure 7-4. SPI Frames for Reading Data

7.3.9.1 Status Flags

Status flags can be appended to the ADC output by setting `APPEND_STATUS = 10b`. The status flag is appended only to frames where ADC data are being read. Status flags are not appended to data corresponding to a register read operation or when `FIX_PAT = 1b`. The 4-bit status flag field is constructed as follows:

Status flag[3:0] = { 1, VTEST_MODE, CRCERR_IN, DIAG_MODE }

where:

- **VTEST_MODE**: This flag is set if the current data frame corresponds to fixed voltage test mode (see the [Fixed Voltage Test Mode](#) section).
- **CRCERR_IN**: This flag indicates the status of the CRC verification of data received from the digital interface. This flag is the same as the `CRCERR_IN` bit in the `SYSTEM_STATUS` register.
- **DIAG_MODE**: This flag is set if the current data frame corresponds to the bit-walk test mode (see the [Bit-Walk Test Mode](#) section).

7.3.9.2 Output CRC (Device to Host)

A CRC byte can be appended to the output data by configuring `CRC_EN` to `1b`. When the CRC module is enabled, the host must use 32-bit frames for SPI communication. The device outputs the data payload followed by the CRC byte computed over the data payload. Additional 0s can be appended by the ADC after the CRC byte to complete the 32-bit SPI frame (see [Table 7-4](#)). The host must compute and compare the CRC corresponding to the data payload with the CRC received from the ADC. The additional 0s appended by the device after the CRC byte must be excluded by the host for computing the CRC.

7.3.9.3 Input CRC (Host to Device)

When the CRC module is enabled, the host must always communicate with the ADC using 32-bit SPI frames comprised of a 24-bit data payload and an 8-bit CRC byte. The host must calculate the CRC byte to be appended based on a 24-bit payload. The ADC computes a CRC over the 24-bit data payload and compares the result with the CRC received from the host. [Table 7-4](#) lists the output data frames for the `CRC_EN` bit.

Table 7-4. Output Data Frames

| CRC_EN | OSR[2:0] | APPEND_STATUS[1:0] | OUTPUT DATA FRAME | DAISY-CHAIN MODE |
|----------------------------------|-------------------|-----------------------|---|------------------|
| CRC module disabled (CRC_EN = 0) | No averaging | No flags (00b or 11b) | {Conversion result [15:0], 8'b0} | Supported |
| | | Channel ID (01b) | {Conversion result [15:0], CHID[3:0], 4'b0} | Supported |
| | | Status flags (10b) | {Conversion result [15:0], status flags[3:0], 4'b0} | Supported |
| | Averaging enabled | No flags (00b or 11b) | {Conversion result [19:0], 4'b0} | Supported |
| | | Channel ID (01b) | {Conversion result [19:0], CHID[3:0]} | Supported |
| | | Status flags (10b) | {Conversion result [19:0], status flags[3:0]} | Supported |
| CRC module enabled (CRC_EN = 1) | No averaging | No flags (00b or 11b) | {Conversion result [15:0], CRC[7:0], 8'b0} | Supported |
| | | Channel ID (01b) | {Conversion result [15:0], CHID[3:0], 4'b0, CRC[7:0]} | Not supported |
| | | Status flags (10b) | {Conversion result [15:0], status flags[3:0], 4'b0, CRC[7:0]} | Not supported |
| | Averaging enabled | No flags (00b or 11b) | {Conversion result [19:0], 4'b0, CRC[7:0]} | Not supported |
| | | Channel ID (01b) | {Conversion result [19:0], CHID[3:0], CRC[7:0]} | Not supported |
| | | Status flags (10b) | {Conversion result [19:0], status flags[3:0], CRC[7:0]} | Not supported |

7.3.10 Device Programming

7.3.10.1 Enhanced-SPI Interface

The device features an enhanced-SPI interface that allows the host controller to operate at slower SCLK speeds and still achieve full throughput. As described in Table 7-5, the host controller can use any of the four SPI-compatible protocols (SPI-00, SPI-01, SPI-10, or SPI-11) to access the device.

Table 7-5. SPI Protocols for Configuring the Device

| PROTOCOL | SCLK POLARITY (At the CS Falling Edge) | SCLK PHASE (Capture Edge) | CPOL_CPHA[1:0] | DIAGRAM |
|----------|--|---------------------------|----------------|------------|
| SPI-00 | Low | Rising | 00b | Figure 7-5 |
| SPI-01 | Low | Falling | 01b | Figure 7-6 |
| SPI-10 | High | Falling | 10b | Figure 7-5 |
| SPI-11 | High | Rising | 11b | Figure 7-6 |

On power-up, the device defaults to the SPI-00 protocol for data read and data write operations. To select a different SPI-compatible protocol, program the CPOL_CPHA[1:0] field. This first write operation must adhere to the SPI-00 protocol. Any subsequent data transfer frames must adhere to the newly-selected protocol.

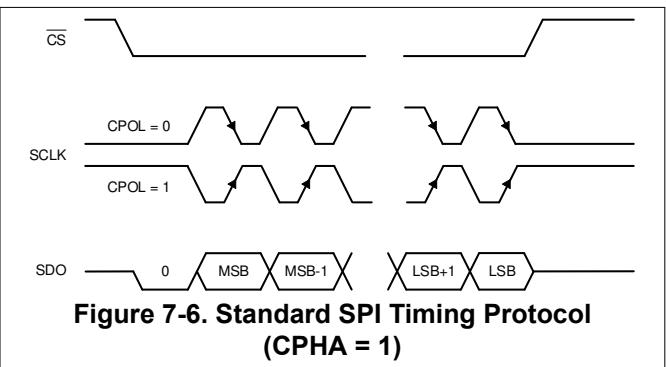
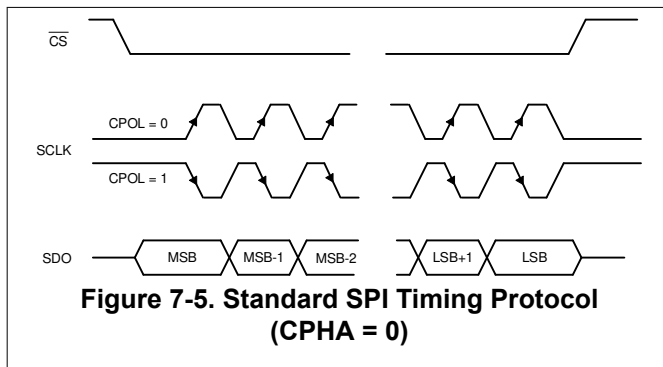

7.3.10.2 Daisy-Chain Mode

The ADS7066 can operate as a single converter or in a system with multiple converters. System designers can take advantage of the simple, high-speed, enhanced-SPI serial interface by cascading converters in a daisy-chain configuration when multiple converters are used. No register configuration is required to enable daisy-chain mode. Figure 7-7 shows a typical connection of three converters in daisy-chain mode.

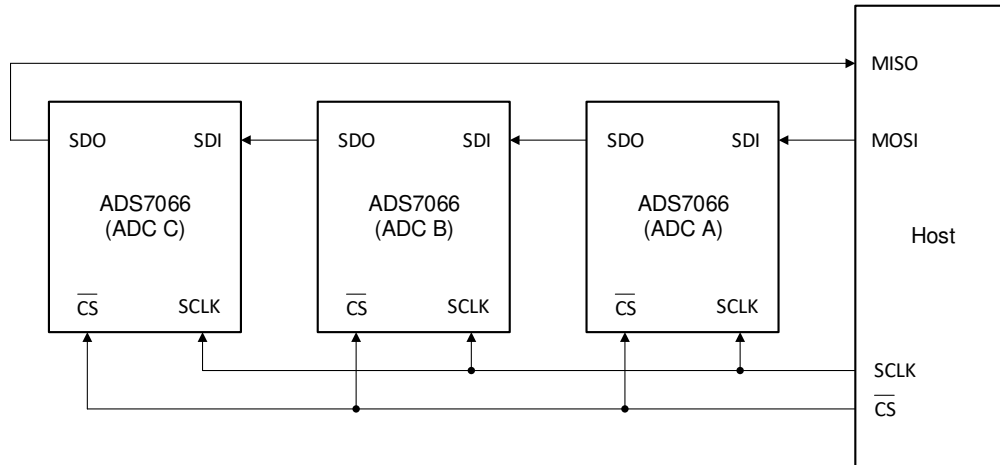

Figure 7-7. Multiple Converters Connected Using Daisy-Chain Mode

When the ADS7066 is connected in daisy-chain mode, the serial input data passes through the ADS7066 with a 24-SCLK delay, as long as CS is active. Figure 7-8 shows a detailed timing diagram of this mode. In Figure 7-8, the conversion in each converter is performed simultaneously.

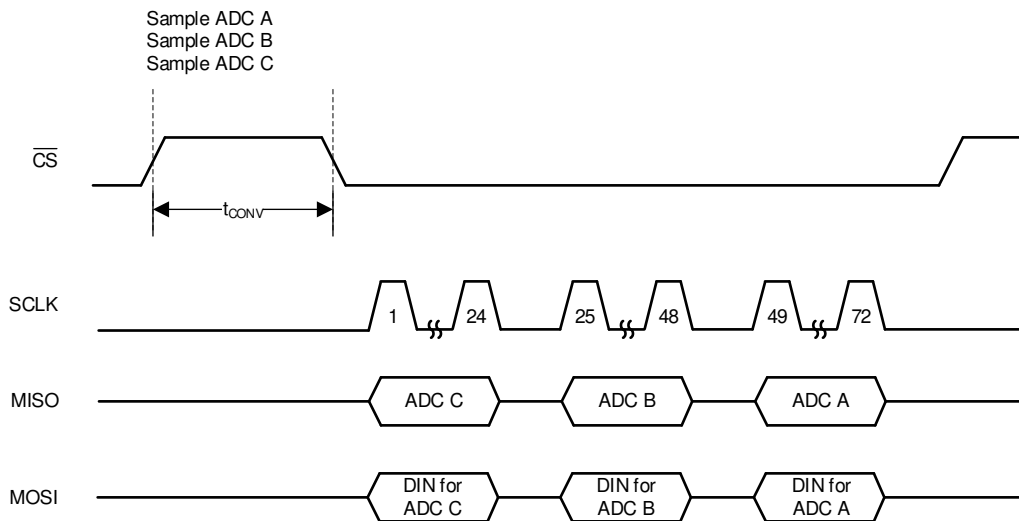

Figure 7-8. Simplified Daisy-Chain Mode Timing

The ADS7066 supports daisy-chain mode for output data payloads up to 24 bits long; see the [Output Data Format](#) section for more details. If either the status flags or channel ID are appended (APPEND_STATUS ≠ 00b) and the CRC module is enabled (CRC_EN = 1b), then the serial input data does not pass through the ADS7066 and daisy-chain mode is disabled.

7.3.10.3 Register Read/Write Operation

The device supports the commands listed in [Table 7-6](#) to access the internal configuration registers

Table 7-6. Opcodes for Commands

| OPCODE | COMMAND DESCRIPTION |
|------------|-----------------------|
| 0000 0000b | No operation |
| 0001 0000b | Single register read |
| 0000 1000b | Single register write |
| 0001 1000b | Set bit |
| 0010 0000b | Clear bit |

The clear bit command clears the specified bits (identified by 1) at the 8-bit address (without affecting the other bits), and the set bit command sets the specified bits (identified by 1) at the 8-bit address (without affecting the other bits).

7.3.10.3.1 Register Write

A 24-bit SPI frame is required to write data to configuration registers. The 24-bit data on SDI, as shown in [Figure 7-9](#), consists of an 8-bit write command (0000 1000b), an 8-bit register address, and 8-bit data. The write command is decoded on the \overline{CS} rising edge and the specified register is updated with the 8-bit data specified in the register write operation.

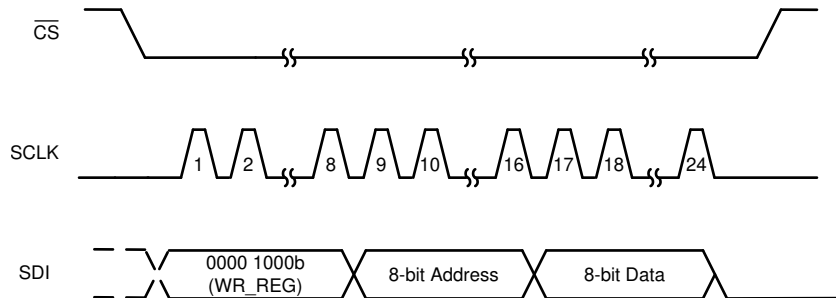

Figure 7-9. Register Write Operation

7.3.10.3.2 Register Read

A register read operation consists of two SPI frames: the first SPI frame initiates a register read and the second SPI frame reads data from the register address provided in the first frame. As shown in Figure 7-10, the read command (0001 0000b), the 8-bit register address, and the 8-bit dummy data are sent over the SDI pin during the first 24-bit frame. On the rising edge of \overline{CS} , the read command is decoded and the requested register data are available for reading during the next frame. During the second frame, the first eight bits on SDO correspond to the requested register read. During the second frame, SDI can be used to initiate another operation or can be set to 0.

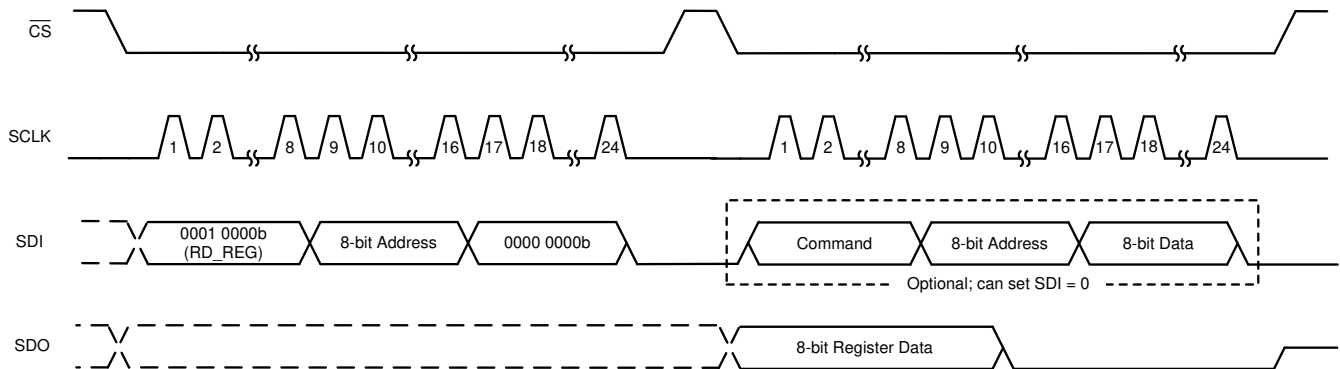

Figure 7-10. Register Read Operation

7.3.10.3.2.1 Register Read With CRC

A register read consists of two SPI frames, as described in the Register Read section. When the CRC module is enabled during a register read, as shown in Figure 7-11, the device appends an 8-bit output CRC byte along with 8-bit register data. The output CRC is computed by the device on the 8-bit register data.

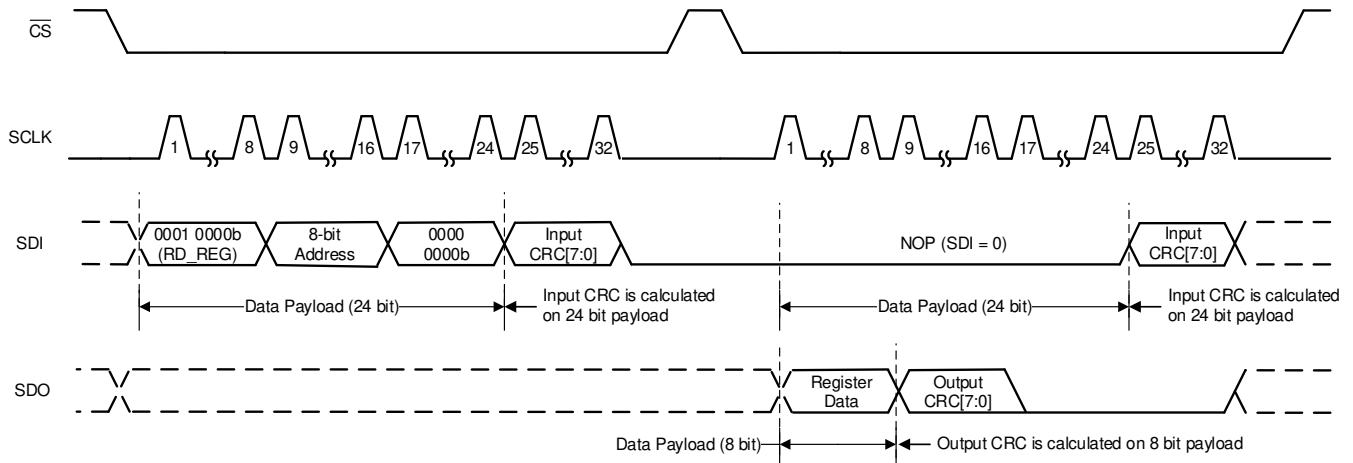

Figure 7-11. Register Read With CRC

7.4 Device Functional Modes

Table 7-7 lists the functional modes supported by the ADS7066.

Table 7-7. Functional Modes

| FUNCTIONAL MODE | CONVERSION CONTROL | MUX CONTROL | SEQ_MODE[1:0] |
|-----------------|-----------------------------|---|---------------|
| Manual | \overline{CS} rising edge | Register write to MANUAL_CHID | 00b |
| On-the-fly | \overline{CS} rising edge | First 5 bits after \overline{CS} falling edge | 10b |
| Auto-sequence | \overline{CS} rising edge | Channel sequencer | 01b |
| Autonomous | Internal to the device | Channel sequencer | 01b |

The device powers up in manual mode and can be configured into either of these modes by writing the configuration registers for the desired mode.

7.4.1 Device Power-Up and Reset

On power up, the BOR bit is set indicating a power-cycle or reset event. The device can be reset by setting the RST bit or by recycling the power on the AVDD pin.

7.4.2 Manual Mode

Manual mode allows the external host processor to directly select the analog input channel. Figure 7-12 shows steps for operating the device in manual mode.

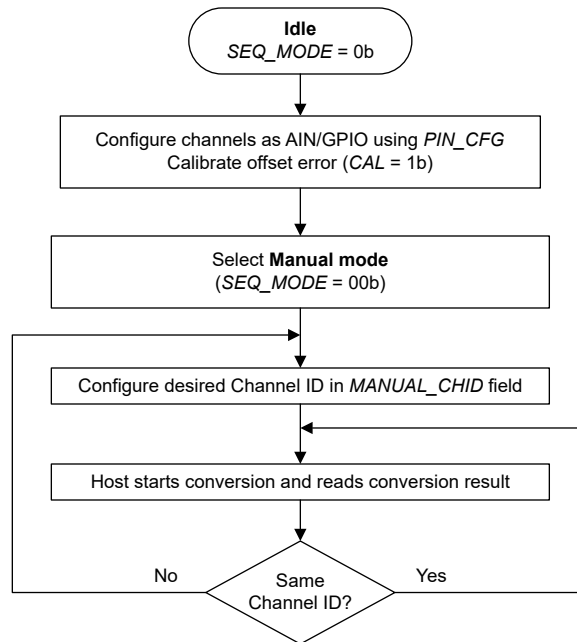

Figure 7-12. Device Operation in Manual Mode

In manual mode, the command to switch to a new channel, cycle N in Figure 7-13, is decoded by the device on the \overline{CS} rising edge. The \overline{CS} rising edge is also the start of the conversion cycle, and thus the device samples the previously selected MUX channel in cycle N+1. The newly selected analog input channel data are available in cycle N+2. For switching the analog input channel, a register write to the MANUAL_CHID field requires 24 clocks; see the Register Write section for more details. After a channel is selected, the number of clocks required for reading the output data depends on the device output data frame size; see the Output Data Format section for more details.

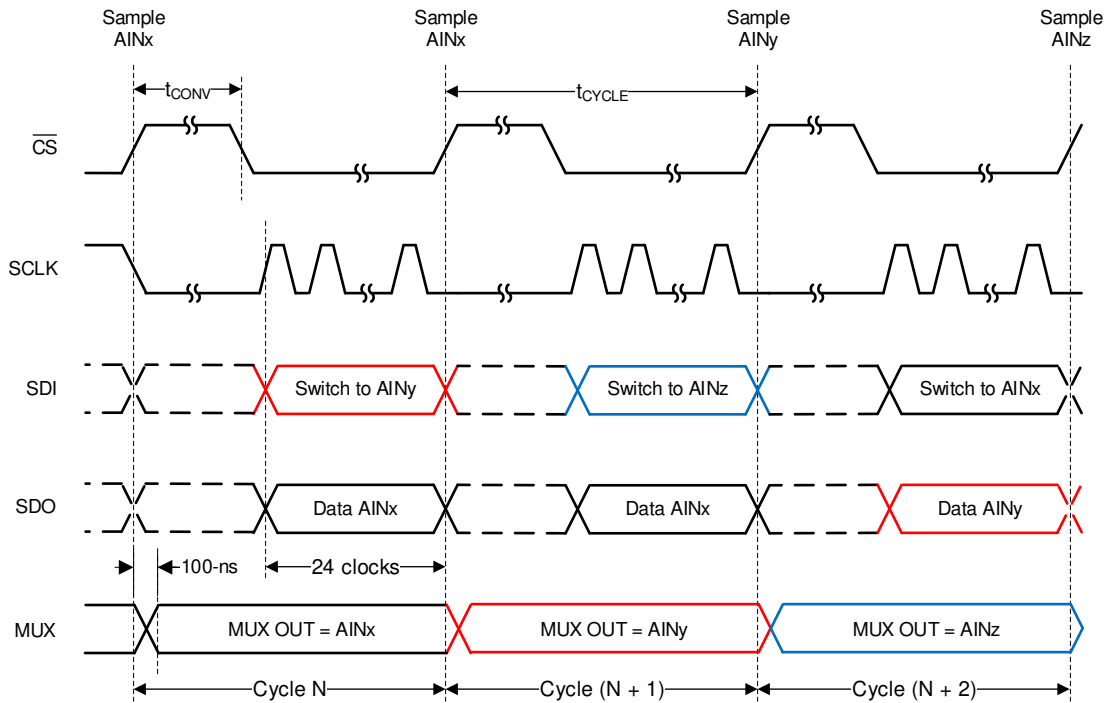

Figure 7-13. Starting a Conversion and Reading Data in Manual Mode

7.4.3 On-the-Fly Mode

In the on-the-fly mode of operation, as shown in Figure 7-14, the analog input channel is selected using the first five bits on SDI without waiting for the \overline{CS} rising edge. Thus, the ADC samples the newly selected channel on the \overline{CS} rising edge and there is no latency between the channel selection and the ADC output data. Table 7-8 lists the channel selection commands for this mode.

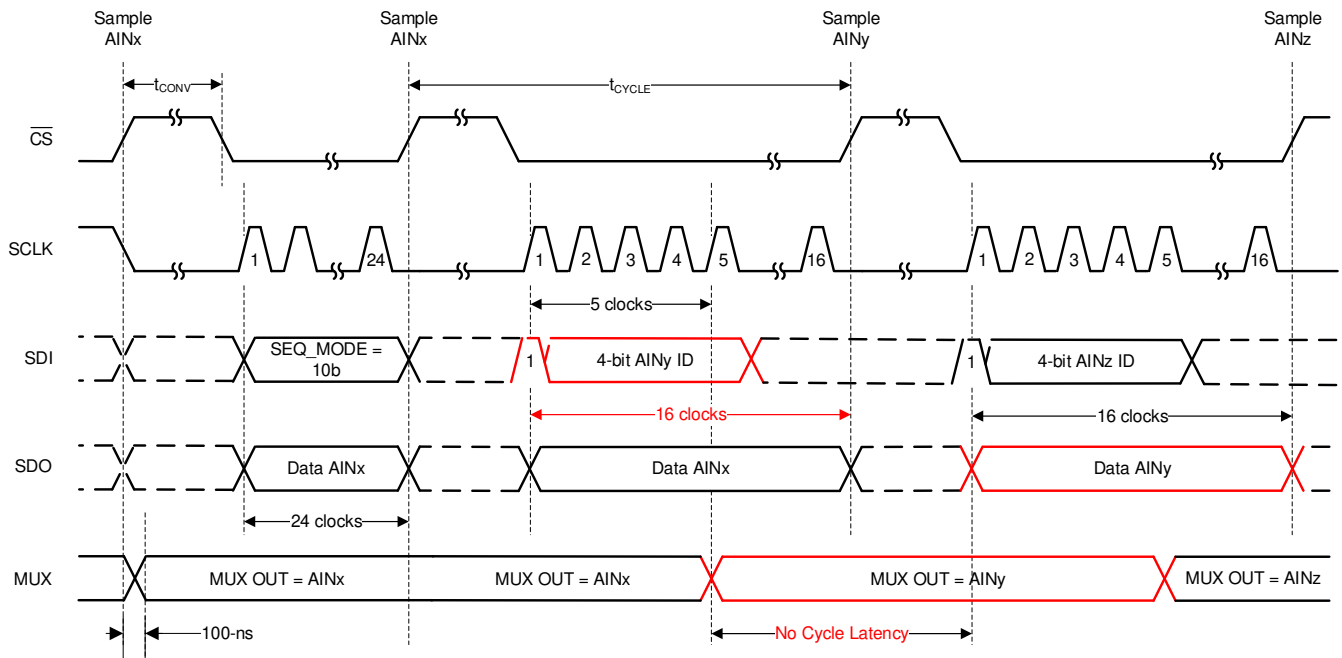

Figure 7-14. Starting a Conversion and Reading data in On-the-Fly Mode

Table 7-8. On-the-Fly Mode Channel Selection Commands

| SDI BITS[15:11] | SDI BITS [10:0] | DESCRIPTION |
|------------------|-----------------|-----------------------|
| 1 0000 | Don't care | Select analog input 0 |
| 1 0001 | Don't care | Select analog input 1 |
| 1 0010 | Don't care | Select analog input 2 |
| 1 0011 | Don't care | Select analog input 3 |
| 1 0100 | Don't care | Select analog input 4 |
| 1 0101 | Don't care | Select analog input 5 |
| 1 0110 | Don't care | Select analog input 6 |
| 1 0111 | Don't care | Select analog input 7 |
| 1 1000 to 1 1111 | Don't care | Reserved |

The number of clocks required for reading the output data depends on the device output data frame size; see the [Output Data Format](#) section for more details.

7.4.4 Auto-Sequence Mode

In auto-sequence mode, the internal channel sequencer switches the multiplexer to the next analog input channel after every conversion. The desired analog input channels can be configured for sequencing in the AUTO_SEQ_CHSEL register. To enable the channel sequencer, set SEQ_START = 1b. After every conversion, the channel sequencer switches the multiplexer to the next analog input in ascending order. To stop the channel sequencer from selecting channels, set SEQ_START = 0b.

In the example shown in [Figure 7-15](#), AIN2 and AIN6 are enabled for sequencing in the AUTO_SEQ_CHSEL register. The channel sequencer loops through AIN2 and AIN6 and repeats until SEQ_START is set to 0b. The number of clocks required for reading the output data depends on the device output data frame size; see the [Output Data Format](#) section for more details.

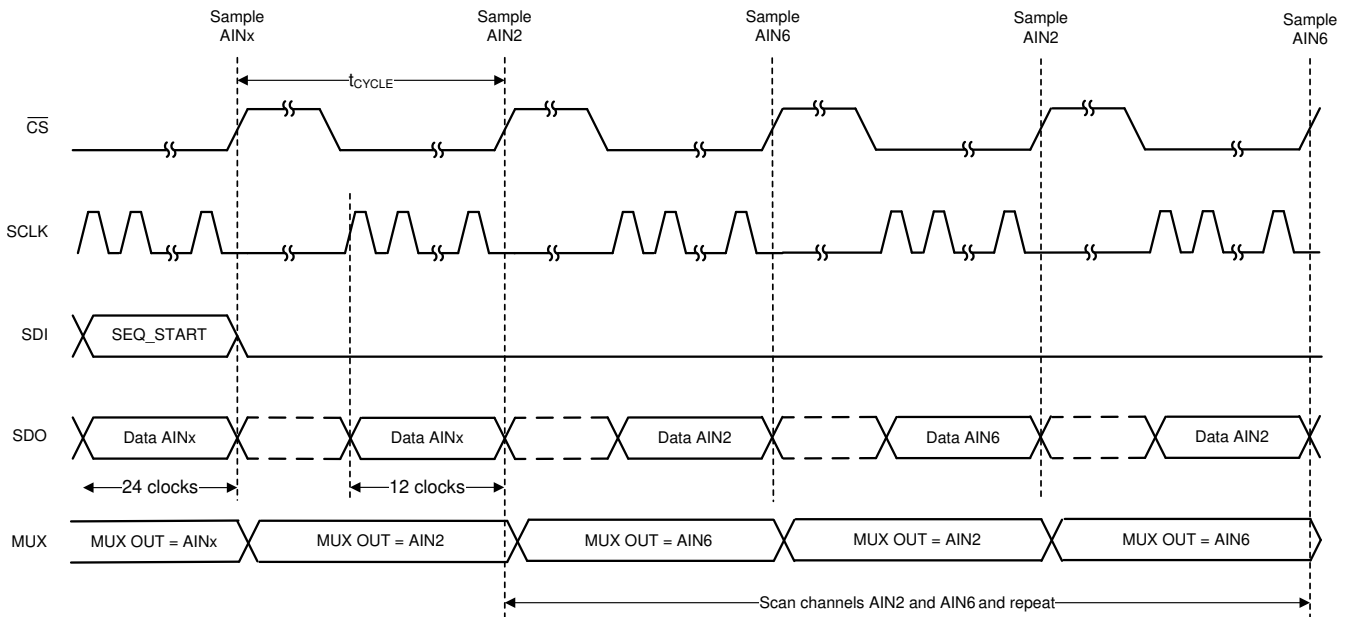

Figure 7-15. Starting Conversion and Reading Data in Auto-Sequence Mode

7.5 ADS7066 Registers

[ADS7066 Registers](#) lists the memory-mapped registers for the ADS7066 registers. All register offset addresses not listed in [ADS7066 Registers](#) should be considered as reserved locations and the register contents should not be modified.

Table 7-9. ADS7066 Registers

| Address | Acronym | Register Name | Section |
|---------|------------------|--|---------|
| 0x0 | SYSTEM_STATUS | SYSTEM_STATUS Register (Address = 0x0) [Reset = 0x81] | |
| 0x1 | GENERAL_CFG | GENERAL_CFG Register (Address = 0x1) [Reset = 0x00] | |
| 0x2 | DATA_CFG | DATA_CFG Register (Address = 0x2) [Reset = 0x00] | |
| 0x3 | OSR_CFG | OSR_CFG Register (Address = 0x3) [Reset = 0x00] | |
| 0x4 | OPMODE_CFG | OPMODE_CFG Register (Address = 0x4) [Reset = 0x04] | |
| 0x5 | PIN_CFG | PIN_CFG Register (Address = 0x5) [Reset = 0x00] | |
| 0x7 | GPIO_CFG | GPIO_CFG Register (Address = 0x7) [Reset = 0x00] | |
| 0x9 | GPO_DRIVE_CFG | GPO_DRIVE_CFG Register (Address = 0x9) [Reset = 0x00] | |
| 0xB | GPO_OUTPUT_VALUE | GPO_OUTPUT_VALUE Register (Address = 0xB) [Reset = 0x00] | |
| 0xD | GPI_VALUE | GPI_VALUE Register (Address = 0xD) [Reset = 0x00] | |
| 0x10 | SEQUENCE_CFG | SEQUENCE_CFG Register (Address = 0x10) [Reset = 0x00] | |
| 0x11 | CHANNEL_SEL | CHANNEL_SEL Register (Address = 0x11) [Reset = 0x00] | |
| 0x12 | AUTO_SEQ_CH_SEL | AUTO_SEQ_CH_SEL Register (Address = 0x12) [Reset = 0x00] | |
| 0xBF | DIAGNOSTICS_KEY | DIAGNOSTICS_KEY Register (Address = 0xBF) [Reset = 0x00] | |
| 0xC0 | DIAGNOSTICS_EN | DIAGNOSTICS_EN Register (Address = 0xC0) [Reset = 0x00] | |
| 0xC1 | BIT_SAMPLE_LSB | BIT_SAMPLE_LSB Register (Address = 0xC1) [Reset = 0x00] | |
| 0xC2 | BIT_SAMPLE_MSB | BIT_SAMPLE_MSB Register (Address = 0xC2) [Reset = 0x00] | |

Complex bit access types are encoded to fit into small table cells. [ADS7066 Access Type Codes](#) shows the codes that are used for access types in this section.

Table 7-10. ADS7066 Access Type Codes

| Access Type | Code | Description |
|---------------------------------|------|--|
| Read Type | | |
| R | R | Read |
| Write Type | | |
| W | W | Write |
| Reset or Default Value | | |
| -n | | Value after reset or the default value |
| Register Array Variables | | |
| i,j,k,l,m,n | | When these variables are used in a register name, an offset, or an address, they refer to the value of a register array where the register is part of a group of repeating registers. The register groups form a hierarchical structure and the array is represented with a formula. |
| y | | When this variable is used in a register name, an offset, or an address it refers to the value of a register array. |

7.5.1 SYSTEM_STATUS Register (Address = 0x0) [Reset = 0x81]

SYSTEM_STATUS is shown in [SYSTEM_STATUS Register Field Descriptions](#).

Return to the [Summary Table](#).

Table 7-11. SYSTEM_STATUS Register Field Descriptions

| Bit | Field | Type | Reset | Description |
|-----|-------------|------|-------|---|
| 7 | RSVD | R | 1b | Reads return 1b. |
| 6 | SEQ_STATUS | R | 0b | Status of the channel sequencer. 0b = Sequence stopped 1b = Sequence in progress |
| 5-3 | RESERVED | R | 000b | Reserved Bit |
| 2 | CRCERR_FUSE | R | 0b | Device power-up configuration CRC check status. To re-evaluate this bit, software reset the device or power cycle AVDD. 0b = No problems detected in power-up configuration. 1b = Device configuration not loaded correctly. |
| 1 | CRCERR_IN | R/W | 0b | Status of CRC check on incoming data. Write 1b to clear this error flag. 0b = No CRC error. 1b = CRC error detected. All register writes, except to addresses 0x00 and 0x01, are blocked. |
| 0 | BOR | R/W | 1b | Brown out reset indicator. This bit is set if brown out condition occurs or device is power cycled. Write 1b to this bit to clear the flag. 0b = No brown out since last time this bit was cleared. 1b = Brown out condition detected or device power cycled. |

7.5.2 GENERAL_CFG Register (Address = 0x1) [Reset = 0x00]

GENERAL_CFG is shown in [GENERAL_CFG Register Field Descriptions](#).

Return to the [Summary Table](#).

Table 7-12. GENERAL_CFG Register Field Descriptions

| Bit | Field | Type | Reset | Description |
|-----|----------|------|-------|---|
| 7 | REF_EN | R/W | 0b | Enable or disable the internal reference. 0b = Internal reference is powered down. 1b = Internal reference is enabled. |
| 6 | CRC_EN | R/W | 0b | Enable or disable the CRC on device interface. 0b = CRC module disabled. 1b = CRC appended to data output. CRC check is enabled on incoming data. |
| 5-4 | RESERVED | R | 00b | Reserved Bit |
| 3 | RANGE | R/W | 0b | Select the input range of the ADC. 0b = Input range of the ADC is 1x VREF 1b = Input range of the ADC is 2x VREF |
| 2 | CH_RST | R/W | 0b | Force all channels to be analog inputs. 0b = Normal operation 1b = All channels will be set as analog inputs irrespective of configuration in other registers |
| 1 | CAL | R/W | 0b | Calibrate ADC offset. 0b = Normal operation. 1b = ADC offset is calibrated. After calibration is complete, this bit is set to 0b. |

Table 7-12. GENERAL_CFG Register Field Descriptions (continued)

| Bit | Field | Type | Reset | Description |
|-----|-------|------|-------|---|
| 0 | RST | W | 0b | Software reset all registers to default values. 0b = Normal operation. 1b = Device is reset. After reset is complete, this bit is set to 0b and BOR bit is set to 1b. |

7.5.3 DATA_CFG Register (Address = 0x2) [Reset = 0x00]

DATA_CFG is shown in [DATA_CFG Register Field Descriptions](#).

Return to the [Summary Table](#).

Table 7-13. DATA_CFG Register Field Descriptions

| Bit | Field | Type | Reset | Description |
|-----|--------------------|------|-------|--|
| 7 | FIX_PAT | R/W | 0b | Device outputs fixed data bits which can be helpful for debugging communication with the device. 0b = Normal operation. 1b = Device outputs fixed code 0xA5A5 repeatedly when reading ADC data. |
| 6 | RESERVED | R | 0b | Reserved Bit |
| 5-4 | APPEND_STATUS[1:0] | R/W | 00b | Append 4-bit channel ID or status flags to output data. 00b = Channel ID and status flags are not appended to ADC data. 01b = 4-bit channel ID is appended to ADC data. 10b = 4-bit status flags are appended to ADC data. 11b = Reserved. |
| 3-2 | RESERVED | R | 00b | Reserved Bit |
| 1-0 | CPOL_CPHA[1:0] | R/W | 00b | This field sets the polarity and phase of SPI communication. 00b = CPOL = 0, CPHA = 0. 01b = CPOL = 0, CPHA = 1. 10b = CPOL = 1, CPHA = 0. 11b = CPOL = 1, CPHA = 1. |

7.5.4 OSR_CFG Register (Address = 0x3) [Reset = 0x00]

OSR_CFG is shown in [OSR_CFG Register Field Descriptions](#).

Return to the [Summary Table](#).

Table 7-14. OSR_CFG Register Field Descriptions

| Bit | Field | Type | Reset | Description |
|-----|----------|------|--------|---|
| 7-3 | RESERVED | R | 00000b | Reserved Bit |
| 2-0 | OSR[2:0] | R/W | 000b | Selects the oversampling ratio for ADC conversion result. 000b = No averaging 001b = 2 samples 010b = 4 samples 011b = 8 samples 100b = 16 samples 101b = 32 samples 110b = 64 samples 111b = 128 samples |

7.5.5 OPMODE_CFG Register (Address = 0x4) [Reset = 0x04]

OPMODE_CFG is shown in [OPMODE_CFG Register Field Descriptions](#).

Return to the [Summary Table](#).

Table 7-15. OPMODE_CFG Register Field Descriptions

| Bit | Field | Type | Reset | Description |
|-----|--------------|------|-------|---|
| 7-5 | RESERVED | R | 000b | Reserved Bit |
| 4 | OSC_SEL | R/W | 0b | Selects the oscillator for internal timing generation. 0b = High-speed oscillator. 1b = Low-power oscillator. |
| 3-0 | CLK_DIV[3:0] | R/W | 0100b | Sampling speed control when using averaging filters. Refer to section on oscillator and timing control for details. |

7.5.6 PIN_CFG Register (Address = 0x5) [Reset = 0x00]

PIN_CFG is shown in [PIN_CFG Register Field Descriptions](#).

Return to the [Summary Table](#).

Table 7-16. PIN_CFG Register Field Descriptions

| Bit | Field | Type | Reset | Description |
|-----|--------------|------|-----------|---|
| 7-0 | PIN_CFG[7:0] | R/W | 00000000b | Configure device channels AIN/GPIO [7:0] as analog inputs or GPIOs. 00000000b = Channel is configured as analog input. 00000001b = Channel is configured as GPIO. |

7.5.7 GPIO_CFG Register (Address = 0x7) [Reset = 0x00]

GPIO_CFG is shown in [GPIO_CFG Register Field Descriptions](#).

Return to the [Summary Table](#).

Table 7-17. GPIO_CFG Register Field Descriptions

| Bit | Field | Type | Reset | Description |
|-----|---------------|------|-----------|---|
| 7-0 | GPIO_CFG[7:0] | R/W | 00000000b | Configure GPIO[7:0] as either digital inputs or digital outputs. 00000000b = GPIO is configured as digital input. 00000001b = GPIO is configured as digital output. |

7.5.8 GPO_DRIVE_CFG Register (Address = 0x9) [Reset = 0x00]

GPO_DRIVE_CFG is shown in [GPO_DRIVE_CFG Register Field Descriptions](#).

Return to the [Summary Table](#).

Table 7-18. GPO_DRIVE_CFG Register Field Descriptions

| Bit | Field | Type | Reset | Description |
|-----|--------------------|------|-----------|---|
| 7-0 | GPO_DRIVE_CFG[7:0] | R/W | 00000000b | Configure digital outputs GPO[7:0] as open-drain or push-pull outputs. 00000000b = Digital output is open-drain; connect external pullup resistor. 00000001b = Push-pull driver is used for digital output. |

7.5.9 GPO_OUTPUT_VALUE Register (Address = 0xB) [Reset = 0x00]

GPO_OUTPUT_VALUE is shown in [GPO_OUTPUT_VALUE Register Field Descriptions](#).

Return to the [Summary Table](#).

Table 7-19. GPO_OUTPUT_VALUE Register Field Descriptions

| Bit | Field | Type | Reset | Description |
|-----|-----------------------|------|-----------|--|
| 7-0 | GPO_OUTPUT_VALUE[7:0] | R/W | 00000000b | Logic level to be set on digital outputs GPO[7:0]. 00000000b = Digital output set to logic 0. 00000001b = Digital output set to logic 1. |

7.5.10 GPI_VALUE Register (Address = 0xD) [Reset = 0x00]

GPI_VALUE is shown in [GPI_VALUE Register Field Descriptions](#).

Return to the [Summary Table](#).

Table 7-20. GPI_VALUE Register Field Descriptions

| Bit | Field | Type | Reset | Description |
|-----|----------------|------|-----------|--|
| 7-0 | GPI_VALUE[7:0] | R | 00000000b | Readback the logic level on GPIO[7:0]. 00000000b = GPIO is at logic 0. 00000001b = GPIO is at logic 1. |

7.5.11 SEQUENCE_CFG Register (Address = 0x10) [Reset = 0x00]

SEQUENCE_CFG is shown in [SEQUENCE_CFG Register Field Descriptions](#).

Return to the [Summary Table](#).

Table 7-21. SEQUENCE_CFG Register Field Descriptions

| Bit | Field | Type | Reset | Description |
|-----|---------------|------|-------|---|
| 7-5 | RESERVED | R | 000b | Reserved Bit |
| 4 | SEQ_START | R/W | 0b | Control for start of channel sequence when using auto sequence mode (SEQ_MODE = 01b). 0b = Stop channel sequencing. 1b = Start channel sequencing in ascending order for channels enabled in AUTO_SEQ_CH_SEL register. |
| 3-2 | RESERVED | R | 00b | Reserved Bit |
| 1-0 | SEQ_MODE[1:0] | R/W | 00b | Selects the mode of scanning of analog input channels. 00b = Manual sequence mode; channel selected by MANUAL_CHID field. 01b = Auto sequence mode; channel selected by AUTO_SEQ_CHSEL. 10b = On-the-fly sequence mode. 11b = Reserved. |

7.5.12 CHANNEL_SEL Register (Address = 0x11) [Reset = 0x00]

CHANNEL_SEL is shown in [CHANNEL_SEL Register Field Descriptions](#).

Return to the [Summary Table](#).

Table 7-22. CHANNEL_SEL Register Field Descriptions

| Bit | Field | Type | Reset | Description |
|-----|----------|------|-------|--------------|
| 7-4 | RESERVED | R | 0000b | Reserved Bit |

Table 7-22. CHANNEL_SEL Register Field Descriptions (continued)

| Bit | Field | Type | Reset | Description |
|-----|------------------|------|-------|---|
| 3-0 | MANUAL_CHID[3:0] | R/W | 0000b | In manual mode (SEQ_MODE = 00b), this field contains the 4-bit channel ID of the analog input channel for next ADC conversion. For valid ADC data, the selected channel must not be configured as GPIO in PIN_CFG register. 1xxx = Reserved. 0000b = AIN0 0001b = AIN1 0010b = AIN2 0011b = AIN3 0100b = AIN4 0101b = AIN5 0110b = AIN6 0111b = AIN7 1000b = Reserved. |

7.5.13 AUTO_SEQ_CH_SEL Register (Address = 0x12) [Reset = 0x00]

AUTO_SEQ_CH_SEL is shown in [AUTO_SEQ_CH_SEL Register Field Descriptions](#).

Return to the [Summary Table](#).

Table 7-23. AUTO_SEQ_CH_SEL Register Field Descriptions

| Bit | Field | Type | Reset | Description |
|-----|----------------------|------|-----------|--|
| 7-0 | AUTO_SEQ_CH_SEL[7:0] | R/W | 00000000b | Select analog input channels AIN[7:0] in for auto sequencing mode. 00000000b = Analog input channel is not enabled in scanning sequence. 00000001b = Analog input channel is enabled in scanning sequence. |

7.5.14 DIAGNOSTICS_KEY Register (Address = 0xBF) [Reset = 0x00]

DIAGNOSTICS_KEY is shown in [DIAGNOSTICS_KEY Register Field Descriptions](#).

Return to the [Summary Table](#).

Table 7-24. DIAGNOSTICS_KEY Register Field Descriptions

| Bit | Field | Type | Reset | Description |
|-----|---------------|------|-----------|--|
| 7-0 | DIAG_KEY[7:0] | R/W | 00000000b | Enable write access to diagnostics registers in address locations 0xC0, 0xC1, and 0xC2. Write 0x96 to this register to enable write access to diagnostics registers. |

7.5.15 DIAGNOSTICS_EN Register (Address = 0xC0) [Reset = 0x00]

DIAGNOSTICS_EN is shown in [DIAGNOSTICS_EN Register Field Descriptions](#).

Return to the [Summary Table](#).

Table 7-25. DIAGNOSTICS_EN Register Field Descriptions

| Bit | Field | Type | Reset | Description |
|-----|----------|------|-------|--------------|
| 7-5 | RESERVED | R | 000b | Reserved Bit |

Table 7-25. DIAGNOSTICS_EN Register Field Descriptions (continued)

| Bit | Field | Type | Reset | Description |
|-----|------------|------|-------|---|
| 4 | VTEST_EN | R/W | 0b | Enable measurement of internal 1.8 V (typical) test voltage using AIN6. When using this mode, AIN6 pin should not be left floating and should not be connected to any external circuit. If BITWALK_EN = 1b, this bit has no effect. 0b = Normal operation. 1b = AIN6 is internally connected to 1.8V (typical) test voltage. AIN6 pin should be floating and should not be connected to any external circuit. |
| 3-1 | RESERVED | R | 000b | Reserved Bit |
| 0 | BITWALK_EN | R/W | 0b | Enable bit-walk mode of the ADC bit decisions. 0b = Normal operation. 1b = Bit walk mode enabled. |

7.5.16 BIT_SAMPLE_LSB Register (Address = 0xC1) [Reset = 0x00]

BIT_SAMPLE_LSB is shown in [BIT_SAMPLE_LSB Register Field Descriptions](#).

Return to the [Summary Table](#).

Table 7-26. BIT_SAMPLE_LSB Register Field Descriptions

| Bit | Field | Type | Reset | Description |
|-----|---------------------|------|-----------|---|
| 7-0 | BIT_SAMPLE_LSB[7:0] | R/W | 00000000b | Define the [7:0] bit positions during sampling phase of the ADC. This field has no effect when DIAG_EN = 0. |

7.5.17 BIT_SAMPLE_MSB Register (Address = 0xC2) [Reset = 0x00]

BIT_SAMPLE_MSB is shown in [BIT_SAMPLE_MSB Register Field Descriptions](#).

Return to the [Summary Table](#).

Table 7-27. BIT_SAMPLE_MSB Register Field Descriptions

| Bit | Field | Type | Reset | Description |
|-----|---------------------|------|-----------|--|
| 7-0 | BIT_SAMPLE_MSB[7:0] | R/W | 00000000b | Define the [15:8] bit positions during sampling phase of the ADC. This field has no effect when DIAG_EN = 0. |

8 Application and Implementation

Note

Information in the following applications sections is not part of the TI component specification, and TI does not warrant its accuracy or completeness. TI's customers are responsible for determining suitability of components for their purposes, as well as validating and testing their design implementation to confirm system functionality.

8.1 Application Information

The primary circuit required to maximize the performance of a high-precision, successive approximation register (SAR), analog-to-digital converter (ADC) is the input driver circuits. This section details some general principles for designing the input driver circuit for the ADS7066.

8.2 Typical Application

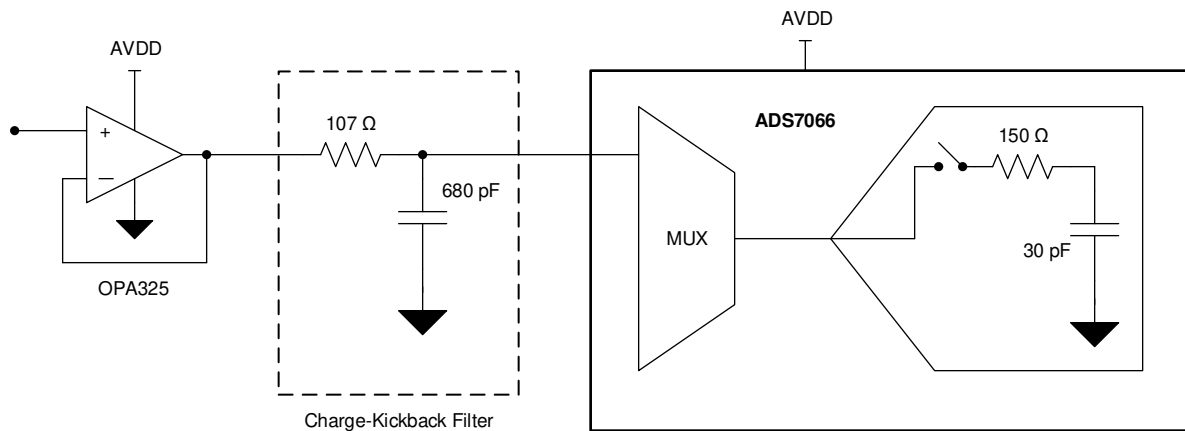

Figure 8-1. DAQ Circuit: Single-Supply DAQ

8.2.1 Design Requirements

The goal of this application is to design a single-supply digital acquisition (DAQ) circuit based on the ADS7066 with SNR greater than 80 dB and THD less than -80 dB for input frequencies of 2 kHz at full throughput.

8.2.2 Detailed Design Procedure

The optimal input driver circuit for a high-precision SAR ADC consists of a driving amplifier and a charge-kickback filter (RC filter). The amplifier driving the ADC must have low output impedance and be able to charge the internal sampling capacitor to a 16-bit settling level within the minimum acquisition time. The charge-kickback filter helps attenuate the sampling charge injection from the switched-capacitor input stage of the ADC and helps reduce the wide-band noise contributed by the front-end circuit.

8.2.2.1 Charge-Kickback Filter and ADC Amplifier

As illustrated in [Figure 8-1](#), a filter capacitor (C_{FLT}) is connected from each input pin of the ADC to ground. This capacitor helps reduce the sampling charge injection and provides a charge bucket to quickly charge the internal sample-and-hold capacitors during the acquisition process. This capacitor must be a COG- or NPO-type. One method for determining the required amplifier bandwidth and the values of the RC charge-kickback filter is provided in this section. This optimization and more details on the math behind the component selection are covered in [ADC Precision Labs](#).

The minimum bandwidth of the amplifier for driving the ADC can be computed using the settling accuracy (0.5 LSB) and settling time (acquisition time) information. [Equation 4](#), [Equation 5](#), [Equation 6](#), and [Equation 7](#) compute the unity-gain bandwidth (UGBW) of the amplifier.

$$LSB = \frac{V_{REF}}{2^N} = \frac{2.5 V}{2^{16}} = 38.2 \mu V \quad (4)$$

$$\tau_c = \frac{-t_{ACQ}}{\ln\left(\frac{0.5 \cdot LSB}{100 mV}\right)} = \frac{-800 ns}{\ln\left(\frac{0.5 \cdot (38.2 \mu V)}{100 mV}\right)} = 93.4 ns \quad (5)$$

$$\tau_{oa} = \frac{\tau_c}{\sqrt{17}} = \frac{93.4 ns}{\sqrt{17}} = 22.7 ns \quad (6)$$

$$UGBW = \frac{1}{2 \cdot \pi \cdot \tau_{oa}} = \frac{1}{2 \cdot \pi \cdot (22.7 ns)} = 7 MHz \quad (7)$$

Based on the result of [Equation 7](#), select an amplifier that has more than 7-MHz UGBW. For this example, [OPA325](#) is used.

The value of C_{filt} is computed in [Equation 8](#) by taking 20 times the internal sample-and-hold capacitance. The factor of 20 is a rule of thumb that is intended to minimize the droop in voltage on the charge-bucket capacitor, C_{filt} , after the start of the acquisition period. The filter resistor, R_{filt} , is computed in [Equation 9](#) using the op-amp time constant and C_{filt} . [Equation 10](#) and [Equation 11](#) compute the minimum and maximum R_{filt} values, respectively.

$$C_{filt} = 20 \cdot C_{SH} = 20 \cdot (30 pF) = 600 pF \quad (8)$$

The value of C_{filt} can be approximated to the nearest standard value 680 pF.

$$R_{filt} = \frac{4 \times \tau_{oa}}{C_{filt}} = \frac{4 \times (22.7 ns)}{680 pF} = 133.5 \Omega \quad (9)$$

$$R_{filt Min} = 0.25 \times R_{filt} = 0.25 \times (133.5 \Omega) = 33.4 \Omega \quad (10)$$

$$R_{filt Max} = 2 \times R_{filt} = 2 \times (133.5 \Omega) = 267 \Omega \quad (11)$$

8.2.3 Application Curve

Figure 8-2 shows the FFT plot for the ADS7066 with a 2-kHz input frequency used for the circuit in Figure 8-1.

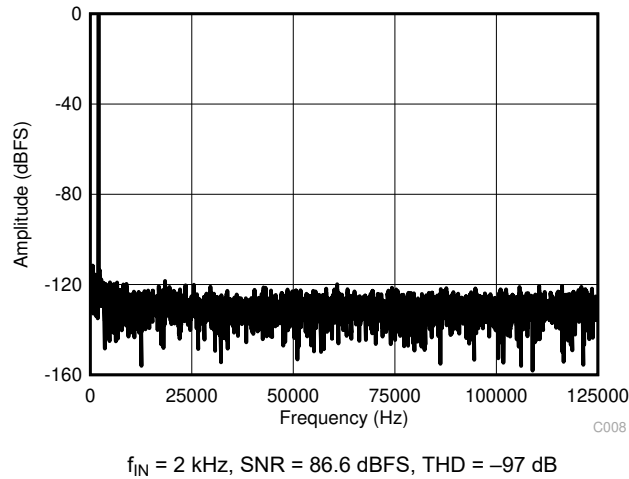

Figure 8-2. Test Results for the Single-Supply DAQ Circuit

8.3 Power Supply Recommendations

8.3.1 AVDD and DVDD Supply Recommendations

The ADS7066 has two separate power supplies: AVDD and DVDD. The device operates on AVDD; DVDD is used for the interface circuits. AVDD and DVDD can be independently set to any value within the permissible ranges. As shown in Figure 8-3, decouple the AVDD and DVDD pins individually with 1- μF ceramic decoupling capacitors.

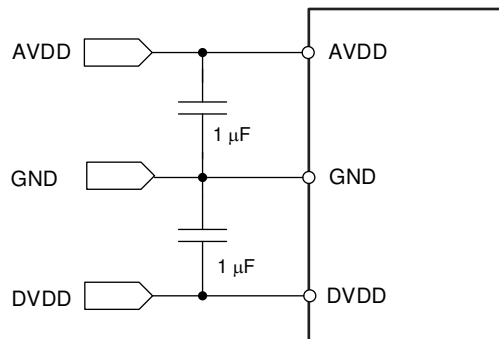

Figure 8-3. Power-Supply Decoupling

8.4 Layout

8.4.1 Layout Guidelines

Figure 8-4 shows a board layout example for the ADS7066. Avoid crossing digital lines with the analog signal path and keep the analog input signals and the reference input signals away from noise sources.

Use 1- μ F ceramic bypass capacitors in close proximity to the analog (AVDD) and digital (DVDD) power-supply pins. Avoid placing vias between the AVDD and DVDD pins and the bypass capacitors. Connect all ground pins to the ground plane using short, low-impedance paths.

Place the reference decoupling capacitor (C_{REF}) close to the device REF and GND pins. Avoid placing vias between the REF pin and the bypass capacitors.

The charge-kickback RC filters are placed close to the device. Among ceramic surface-mount capacitors, COG- or NPO-type ceramic capacitors provide the best capacitance precision. The type of dielectric used in COG- or NPO-type ceramic capacitors provides the most stable electrical properties over voltage, frequency, and temperature changes.

8.4.2 Layout Example

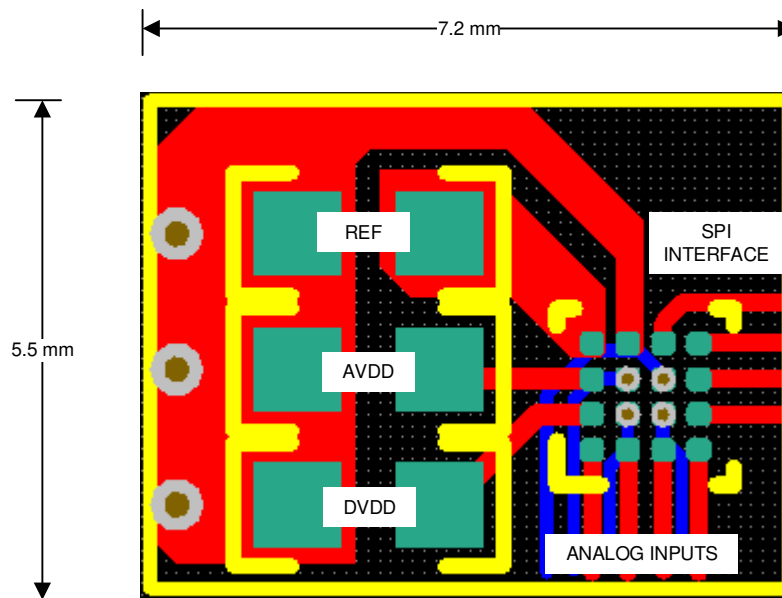

Figure 8-4. Example Layout for DSBGA

9 Device and Documentation Support

9.1 Device Support

9.1.1 Development Support

Texas Instruments, [ADC Precision Labs](#)

9.2 Documentation Support

9.2.1 Related Documentation

For related documentation see the following:

- Texas Instruments, [REF60xx High-Precision Voltage Reference With Integrated ADC Drive Buffer data sheet](#)
- Texas Instruments, [OPAx325 Precision, 10-MHz, Low-Noise, Low-Power, RRIO, CMOS Operational Amplifiers data sheet](#)

9.3 Receiving Notification of Documentation Updates

To receive notification of documentation updates, navigate to the device product folder on [ti.com](#). Click on *Subscribe to updates* to register and receive a weekly digest of any product information that has changed. For change details, review the revision history included in any revised document.

9.4 Support Resources

[TI E2E™ support forums](#) are an engineer's go-to source for fast, verified answers and design help — straight from the experts. Search existing answers or ask your own question to get the quick design help you need.

Linked content is provided "AS IS" by the respective contributors. They do not constitute TI specifications and do not necessarily reflect TI's views; see TI's [Terms of Use](#).

9.5 Trademarks

TI E2E™ is a trademark of Texas Instruments.

All trademarks are the property of their respective owners.

9.6 Electrostatic Discharge Caution



This integrated circuit can be damaged by ESD. Texas Instruments recommends that all integrated circuits be handled with appropriate precautions. Failure to observe proper handling and installation procedures can cause damage.

ESD damage can range from subtle performance degradation to complete device failure. Precision integrated circuits may be more susceptible to damage because very small parametric changes could cause the device not to meet its published specifications.

9.7 Glossary

[TI Glossary](#) This glossary lists and explains terms, acronyms, and definitions.

10 Mechanical, Packaging, and Orderable Information

The following pages include mechanical, packaging, and orderable information. This information is the most current data available for the designated devices. This data is subject to change without notice and revision of this document. For browser-based versions of this data sheet, refer to the left-hand navigation.

PACKAGING INFORMATION

| Orderable Device | Status (1) | Package Type | Package Drawing | Pins | Package Qty | Eco Plan (2) | Lead finish/ Ball material (6) | MSL Peak Temp (3) | Op Temp (°C) | Device Marking (4/5) | Samples |
|------------------|---------------|--------------|-----------------|------|-------------|-----------------|--------------------------------------|----------------------|--------------|-------------------------|-------------------------|
| ADS7066IRTER | ACTIVE | WQFN | RTE | 16 | 5000 | RoHS & Green | NIPDAU | Level-1-260C-UNLIM | -40 to 125 | 7066 | Samples |
| ADS7066IYBHR | ACTIVE | DSBGA | YBH | 16 | 3000 | RoHS & Green | SNAGCU | Level-1-260C-UNLIM | -40 to 125 | ADS7066 | Samples |
| ADS7066IYBHT | ACTIVE | DSBGA | YBH | 16 | 250 | RoHS & Green | SNAGCU | Level-1-260C-UNLIM | -40 to 125 | ADS7066 | Samples |

(1) The marketing status values are defined as follows:

ACTIVE: Product device recommended for new designs.

LIFEBUY: TI has announced that the device will be discontinued, and a lifetime-buy period is in effect.

NRND: Not recommended for new designs. Device is in production to support existing customers, but TI does not recommend using this part in a new design.

PREVIEW: Device has been announced but is not in production. Samples may or may not be available.

OBSOLETE: TI has discontinued the production of the device.

(2) **RoHS:** TI defines "RoHS" to mean semiconductor products that are compliant with the current EU RoHS requirements for all 10 RoHS substances, including the requirement that RoHS substance do not exceed 0.1% by weight in homogeneous materials. Where designed to be soldered at high temperatures, "RoHS" products are suitable for use in specified lead-free processes. TI may reference these types of products as "Pb-Free".

RoHS Exempt: TI defines "RoHS Exempt" to mean products that contain lead but are compliant with EU RoHS pursuant to a specific EU RoHS exemption.

Green: TI defines "Green" to mean the content of Chlorine (Cl) and Bromine (Br) based flame retardants meet JS709B low halogen requirements of <=1000ppm threshold. Antimony trioxide based flame retardants must also meet the <=1000ppm threshold requirement.

(3) MSL, Peak Temp. - The Moisture Sensitivity Level rating according to the JEDEC industry standard classifications, and peak solder temperature.

(4) There may be additional marking, which relates to the logo, the lot trace code information, or the environmental category on the device.

(5) Multiple Device Markings will be inside parentheses. Only one Device Marking contained in parentheses and separated by a "~" will appear on a device. If a line is indented then it is a continuation of the previous line and the two combined represent the entire Device Marking for that device.

(6) Lead finish/Ball material - Orderable Devices may have multiple material finish options. Finish options are separated by a vertical ruled line. Lead finish/Ball material values may wrap to two lines if the finish value exceeds the maximum column width.

Important Information and Disclaimer:The information provided on this page represents TI's knowledge and belief as of the date that it is provided. TI bases its knowledge and belief on information provided by third parties, and makes no representation or warranty as to the accuracy of such information. Efforts are underway to better integrate information from third parties. TI has taken and continues to take reasonable steps to provide representative and accurate information but may not have conducted destructive testing or chemical analysis on incoming materials and chemicals. TI and TI suppliers consider certain information to be proprietary, and thus CAS numbers and other limited information may not be available for release.

In no event shall TI's liability arising out of such information exceed the total purchase price of the TI part(s) at issue in this document sold by TI to Customer on an annual basis.

TAPE AND REEL INFORMATION

QUADRANT ASSIGNMENTS FOR PIN 1 ORIENTATION IN TAPE

*All dimensions are nominal

| Device | Package Type | Package Drawing | Pins | SPQ | Reel Diameter (mm) | Reel Width W1 (mm) | A0 (mm) | B0 (mm) | K0 (mm) | P1 (mm) | W (mm) | Pin1 Quadrant |
|--------------|--------------|-----------------|------|------|--------------------|--------------------|---------|---------|---------|---------|--------|---------------|
| ADS7066IRTER | WQFN | RTE | 16 | 5000 | 330.0 | 12.4 | 3.3 | 3.3 | 1.1 | 8.0 | 12.0 | Q2 |
| ADS7066IYBHR | DSBGA | YBH | 16 | 3000 | 180.0 | 8.4 | 1.8 | 1.8 | 0.52 | 4.0 | 8.0 | Q1 |
| ADS7066IYBHT | DSBGA | YBH | 16 | 250 | 180.0 | 8.4 | 1.8 | 1.8 | 0.52 | 4.0 | 8.0 | Q1 |

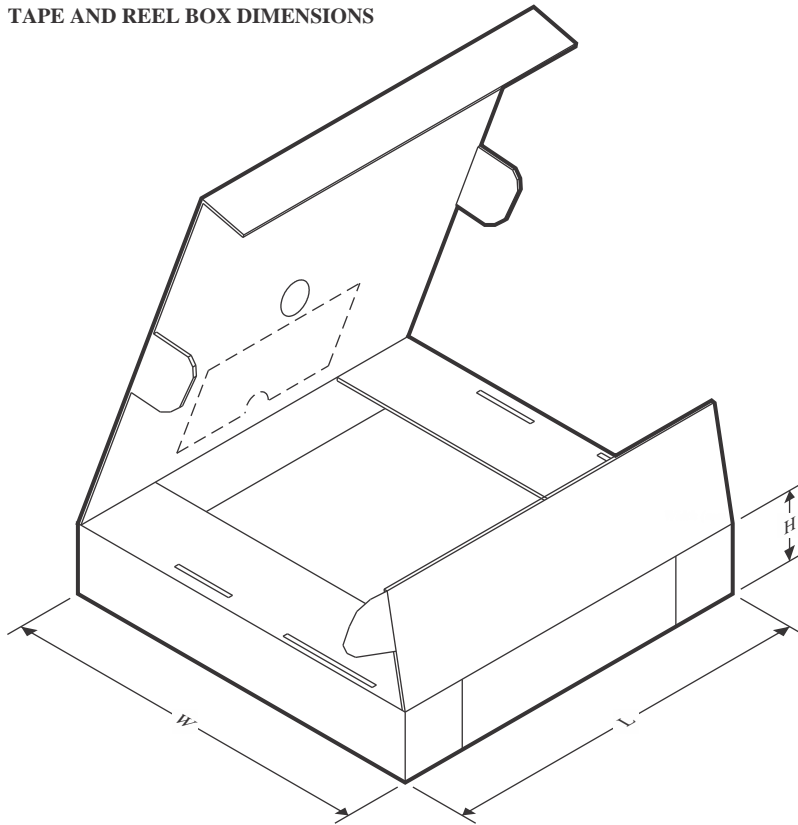
TAPE AND REEL BOX DIMENSIONS

*All dimensions are nominal

| Device | Package Type | Package Drawing | Pins | SPQ | Length (mm) | Width (mm) | Height (mm) |
|--------------|--------------|-----------------|------|------|-------------|------------|-------------|
| ADS7066IRTER | WQFN | RTE | 16 | 5000 | 367.0 | 367.0 | 35.0 |
| ADS7066IYBHR | DSBGA | YBH | 16 | 3000 | 182.0 | 182.0 | 20.0 |
| ADS7066IYBHT | DSBGA | YBH | 16 | 250 | 182.0 | 182.0 | 20.0 |

GENERIC PACKAGE VIEW

RTE 16

WQFN - 0.8 mm max height

3 x 3, 0.5 mm pitch

PLASTIC QUAD FLATPACK - NO LEAD

This image is a representation of the package family, actual package may vary.
Refer to the product data sheet for package details.

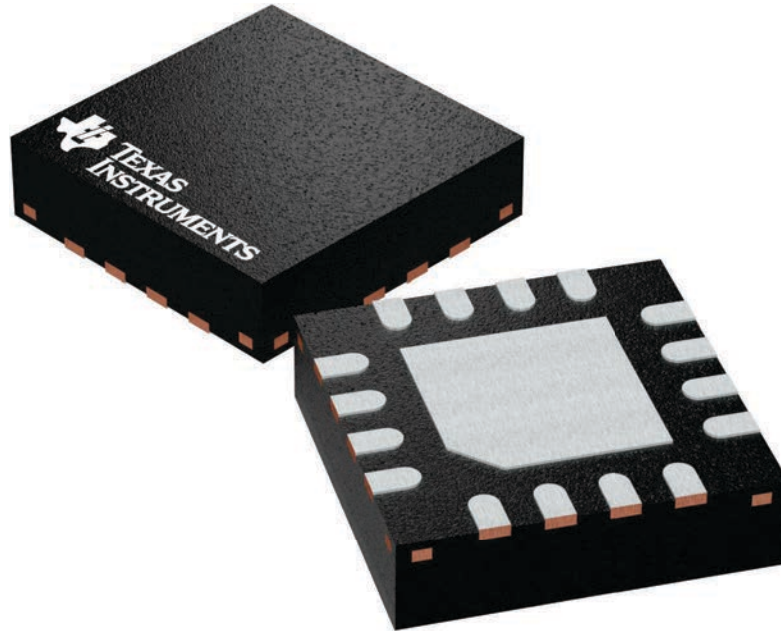

4225944/A

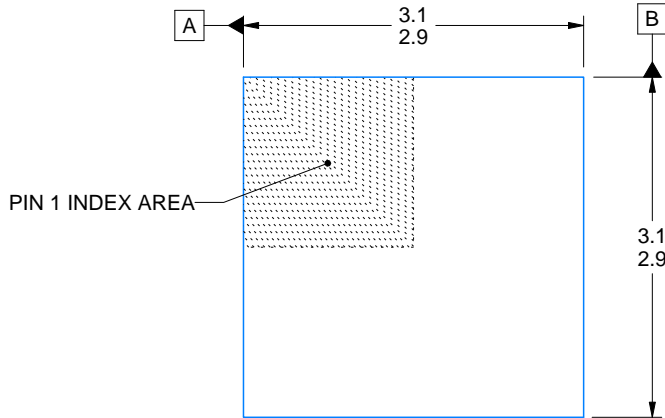

| SIDE WALL METAL THICKNESS DIM A | |
|---------------------------------|----------|
| OPTION 1 | OPTION 2 |
| 0.1 | 0.2 |

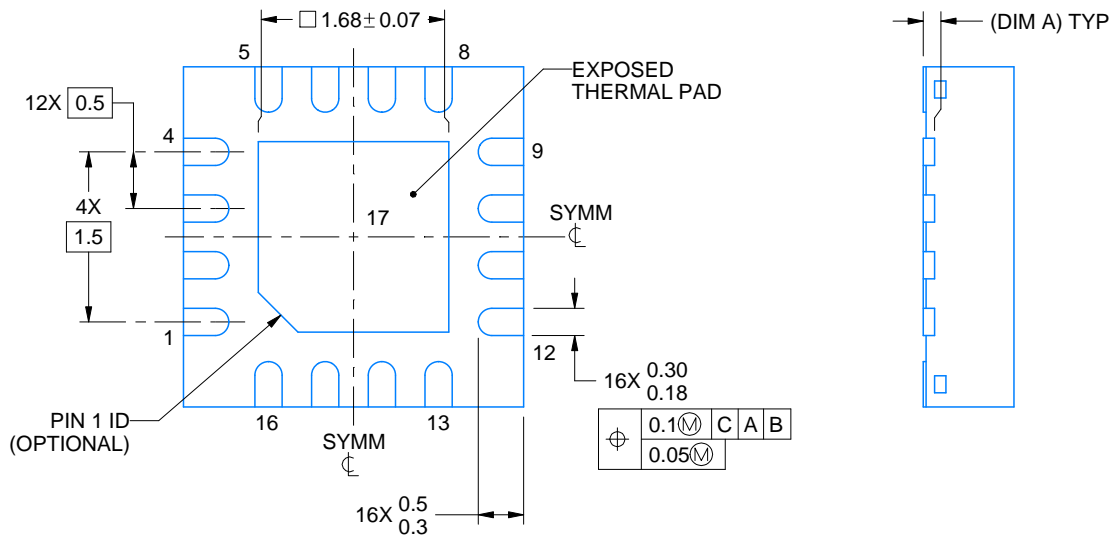
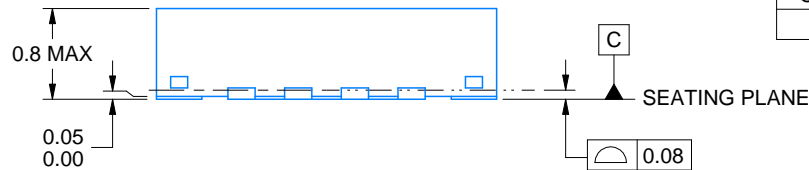

4219117/B 04/2022

NOTES:

1. All linear dimensions are in millimeters. Any dimensions in parenthesis are for reference only. Dimensioning and tolerancing per ASME Y14.5M.
2. This drawing is subject to change without notice.
3. The package thermal pad must be soldered to the printed circuit board for thermal and mechanical performance.

EXAMPLE STENCIL DESIGN

RTE0016C

WQFN - 0.8 mm max height

PLASTIC QUAD FLATPACK - NO LEAD

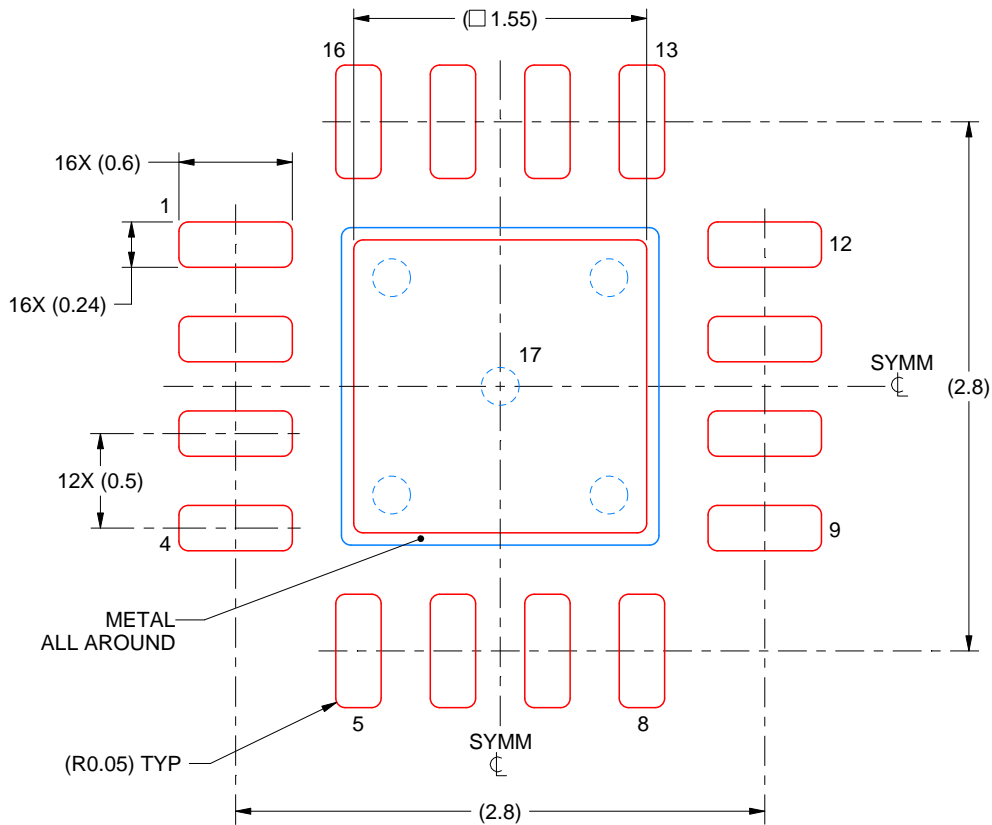

SOLDER PASTE EXAMPLE
BASED ON 0.125 mm THICK STENCIL

EXPOSED PAD 17:
85% PRINTED SOLDER COVERAGE BY AREA UNDER PACKAGE
SCALE:25X

4219117/B 04/2022

NOTES: (continued)

6. Laser cutting apertures with trapezoidal walls and rounded corners may offer better paste release. IPC-7525 may have alternate design recommendations.

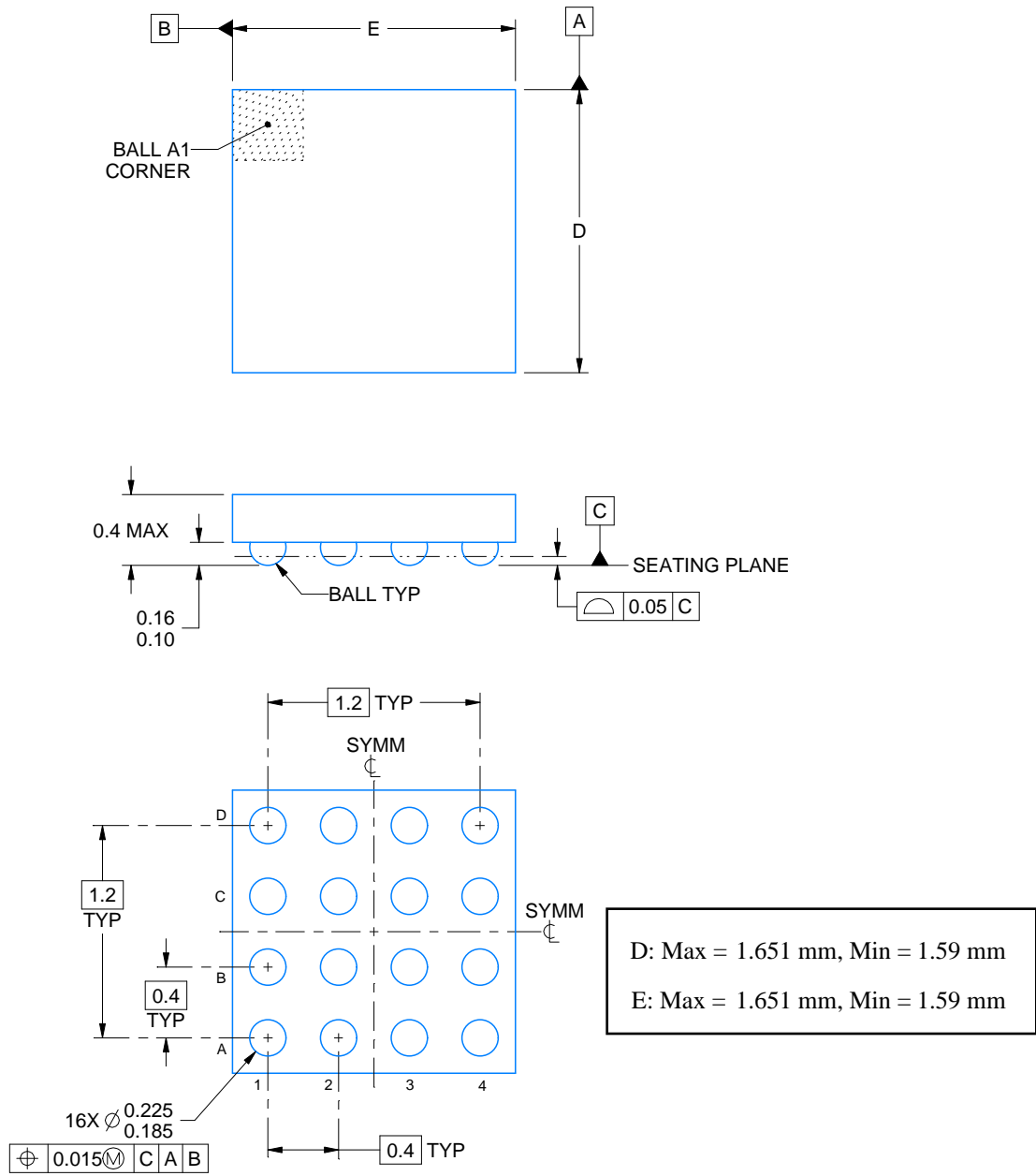
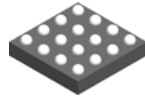

4225022/A 06/2019

NOTES:

1. All linear dimensions are in millimeters. Any dimensions in parenthesis are for reference only. Dimensioning and tolerancing per ASME Y14.5M.
2. This drawing is subject to change without notice.

EXAMPLE BOARD LAYOUT

YBH0016

DSBGA - 0.4 mm max height

DIE SIZE BALL GRID ARRAY

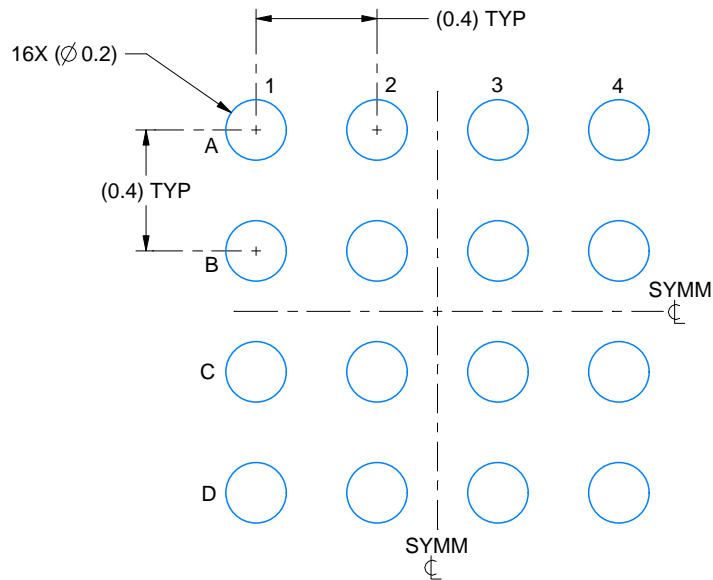

LAND PATTERN EXAMPLE
EXPOSED METAL SHOWN
SCALE: 40X

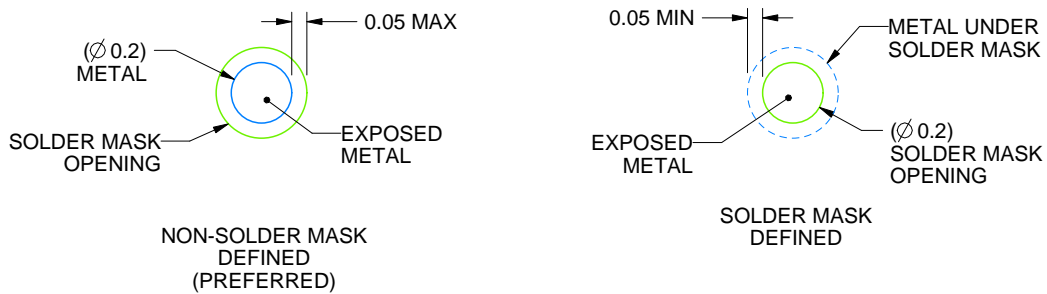

SOLDER MASK DETAILS
NOT TO SCALE

4225022/A 06/2019

NOTES: (continued)

- Final dimensions may vary due to manufacturing tolerance considerations and also routing constraints. See Texas Instruments Literature No. SNVA009 (www.ti.com/lit/snva009).

EXAMPLE STENCIL DESIGN

YBH0016

DSBGA - 0.4 mm max height

DIE SIZE BALL GRID ARRAY

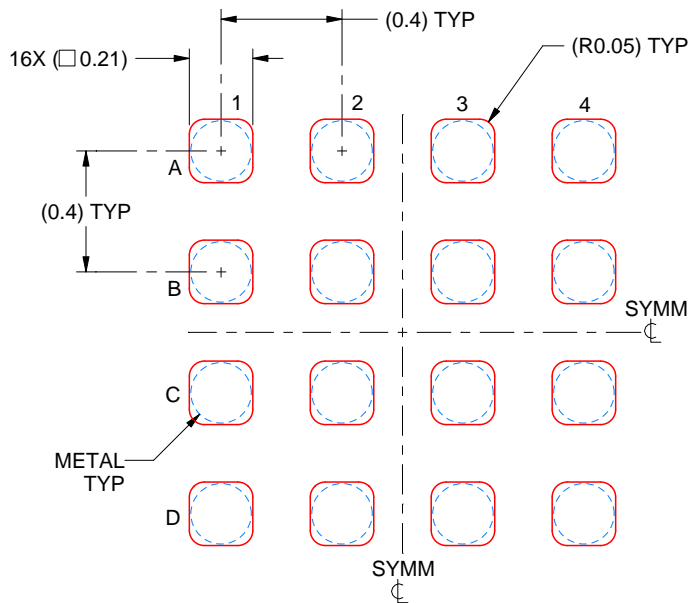

SOLDER PASTE EXAMPLE
BASED ON 0.075 mm THICK STENCIL
SCALE: 40X

4225022/A 06/2019

NOTES: (continued)

4. Laser cutting apertures with trapezoidal walls and rounded corners may offer better paste release.

IMPORTANT NOTICE AND DISCLAIMER

TI PROVIDES TECHNICAL AND RELIABILITY DATA (INCLUDING DATA SHEETS), DESIGN RESOURCES (INCLUDING REFERENCE DESIGNS), APPLICATION OR OTHER DESIGN ADVICE, WEB TOOLS, SAFETY INFORMATION, AND OTHER RESOURCES "AS IS" AND WITH ALL FAULTS, AND DISCLAIMS ALL WARRANTIES, EXPRESS AND IMPLIED, INCLUDING WITHOUT LIMITATION ANY IMPLIED WARRANTIES OF MERCHANTABILITY, FITNESS FOR A PARTICULAR PURPOSE OR NON-INFRINGEMENT OF THIRD PARTY INTELLECTUAL PROPERTY RIGHTS.

These resources are intended for skilled developers designing with TI products. You are solely responsible for (1) selecting the appropriate TI products for your application, (2) designing, validating and testing your application, and (3) ensuring your application meets applicable standards, and any other safety, security, regulatory or other requirements.

These resources are subject to change without notice. TI grants you permission to use these resources only for development of an application that uses the TI products described in the resource. Other reproduction and display of these resources is prohibited. No license is granted to any other TI intellectual property right or to any third party intellectual property right. TI disclaims responsibility for, and you will fully indemnify TI and its representatives against, any claims, damages, costs, losses, and liabilities arising out of your use of these resources.

TI's products are provided subject to [TI's Terms of Sale](#) or other applicable terms available either on [ti.com](https://www.ti.com) or provided in conjunction with such TI products. TI's provision of these resources does not expand or otherwise alter TI's applicable warranties or warranty disclaimers for TI products.

TI objects to and rejects any additional or different terms you may have proposed.

Mailing Address: Texas Instruments, Post Office Box 655303, Dallas, Texas 75265
Copyright © 2023, Texas Instruments Incorporated

Looking for pricing, stock, or lifecycle information?

Click below to explore more details on WIN SOURCE:

 [View ADS7066IYBHR on WIN SOURCE](#)

 [Texas Instruments](#) Information

Optimize Your Supply Chain with WIN SOURCE Solutions

-  Global Sourcing Solution
-  Obsolete Management
-  Cost Control Management
-  Shortage Management
-  Alternative Solution
-  Excess Inventory Management