



THE DATASHEET OF
14066B



MC14066B

Quad Analog Switch/Quad Multiplexer

The MC14066B consists of four independent switches capable of controlling either digital or analog signals. This quad bilateral switch is useful in signal gating, chopper, modulator, demodulator and CMOS logic implementation.

The MC14066B is designed to be pin-for-pin compatible with the MC14016B, but has much lower ON resistance. Input voltage swings as large as the full supply voltage can be controlled via each independent control input.

Features

- Triple Diode Protection on All Control Inputs
- Supply Voltage Range = 3.0 Vdc to 18 Vdc
- Linearized Transfer Characteristics
- Low Noise – $12 \text{ nV}/\sqrt{\text{Cycle}}$, $f \geq 1.0 \text{ kHz}$ typical
- Pin-for-Pin Replacement for CD4016, MC14016B
- For Lower R_{ON} , Use The HC4066 High-Speed CMOS Device
- NLV Prefix for Automotive and Other Applications Requiring Unique Site and Control Change Requirements; AEC-Q100 Qualified and PPAP Capable
- These Devices are Pb-Free and are RoHS Compliant

MAXIMUM RATINGS (Voltages Referenced to V_{SS})

Symbol	Parameter	Value	Unit
V_{DD}	DC Supply Voltage Range	-0.5 to +18.0	V
V_{in}, V_{out}	Input or Output Voltage Range (DC or Transient)	-0.5 to $V_{DD} + 0.5$	V
I_{in}	Input Current (DC or Transient) per Control Pin	± 10	mA
I_{SW}	Switch Through Current	± 25	mA
P_D	Power Dissipation, per Package (Note 1)	500	mW
T_A	Ambient Temperature Range	-55 to +125	$^{\circ}\text{C}$
T_{stg}	Storage Temperature Range	-65 to +150	$^{\circ}\text{C}$
T_L	Lead Temperature (8-Second Soldering)	260	$^{\circ}\text{C}$

Stresses exceeding those listed in the Maximum Ratings table may damage the device. If any of these limits are exceeded, device functionality should not be assumed, damage may occur and reliability may be affected.

1. Temperature Derating: "D/DW" Packages: $-7.0 \text{ mW}/^{\circ}\text{C}$ From 65°C To 125°C

This device contains protection circuitry to guard against damage due to high static voltages or electric fields. However, precautions must be taken to avoid applications of any voltage higher than maximum rated voltages to this high-impedance circuit. For proper operation, V_{in} and V_{out} should be constrained to the range $V_{SS} \leq (V_{in} \text{ or } V_{out}) \leq V_{DD}$.

Unused inputs must always be tied to an appropriate logic voltage level (e.g., either V_{SS} or V_{DD}). Unused outputs must be left open.



ON Semiconductor®

<http://onsemi.com>



SOIC-14
D SUFFIX
CASE 751A

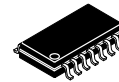

SOEIAJ-14
F SUFFIX
CASE 965



TSSOP-14
DT SUFFIX
CASE 948G

PIN ASSIGNMENT

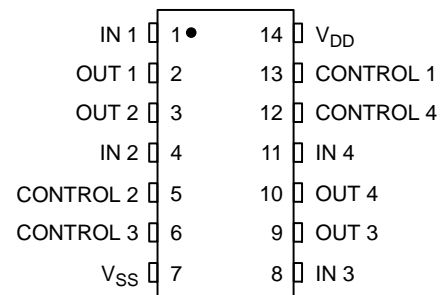

MARKING DIAGRAMS

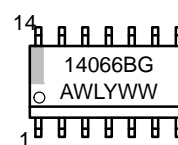

SOIC-14

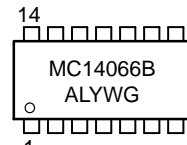

SOEIAJ-14

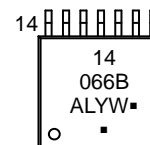

TSSOP-14

- A = Assembly Location
- WL, L = Wafer Lot
- YY, Y = Year
- WW, W = Work Week
- G or ■ = Pb-Free Package

(Note: Microdot may be in either location)

ORDERING INFORMATION

See detailed ordering and shipping information in the package dimensions section on page 8 of this data sheet.

MC14066B

BLOCK DIAGRAM

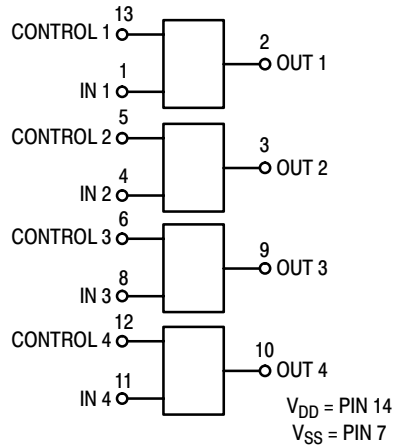

LOGIC DIAGRAM AND TRUTH TABLE (1/4 OF DEVICE SHOWN)

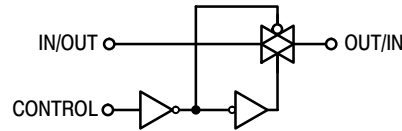

Control	Switch
0 = V_{SS}	OFF
1 = V_{DD}	ON

Logic Diagram Restrictions
 $V_{SS} \leq V_{in} \leq V_{DD}$
 $V_{SS} \leq V_{out} \leq V_{DD}$

CIRCUIT SCHEMATIC (1/4 OF CIRCUIT SHOWN)

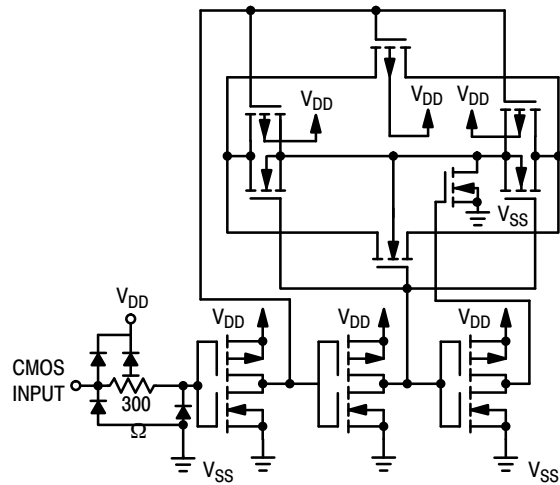

MC14066B

ELECTRICAL CHARACTERISTICS

Characteristic	Symbol	V _{DD}	Test Conditions	-55°C		25°C			125°C		Unit
				Min	Max	Min	Typ (Note 2)	Max	Min	Max	

SUPPLY REQUIREMENTS (Voltages Referenced to V_{EE})

Power Supply Voltage Range	V _{DD}	—		3.0	18	3.0	—	18	3.0	18	V
Quiescent Current Per Package	I _{DD}	5.0 10 15	Control Inputs: V _{in} = V _{SS} or V _{DD} , Switch I/O: V _{SS} ≤ V _{I/O} ≤ V _{DD} , and ΔV _{switch} ≤ 500 mV ⁽³⁾	— — —	0.25 0.5 1.0	— — —	0.005 0.010 0.015	0.25 0.5 1.0	— — —	7.5 15 30	μA
Total Supply Current (Dynamic Plus Quiescent, Per Package)	I _{D(AV)}	5.0 10 15	T _A = 25°C only The channel component, (V _{in} - V _{out})/R _{on} , is not included.)	Typical (0.07 μA/kHz) f + I _{DD} (0.20 μA/kHz) f + I _{DD} (0.36 μA/kHz) f + I _{DD}							μA

CONTROL INPUTS (Voltages Referenced to V_{SS})

Low-Level Input Voltage	V _{IL}	5.0 10 15	R _{on} = per spec, I _{off} = per spec	— — —	1.5 3.0 4.0	— — —	2.25 4.50 6.75	1.5 3.0 4.0	— — —	1.5 3.0 4.0	V
High-Level Input Voltage	V _{IH}	5.0 10 15	R _{on} = per spec, I _{off} = per spec	3.5 7.0 11	— — —	3.5 7.0 11	2.75 5.50 8.25	— — —	3.5 7.0 11	— — —	V
Input Leakage Current	I _{in}	15	V _{in} = 0 or V _{DD}	—	±0.1	—	±0.00001	±0.1	—	±1.0	μA
Input Capacitance	C _{in}	—		—	—	—	5.0	7.5	—	—	pF

SWITCHES IN AND OUT (Voltages Referenced to V_{SS})

Recommended Peak-to-Peak Voltage Into or Out of the Switch	V _{I/O}	—	Channel On or Off	0	V _{DD}	0	—	V _{DD}	0	V _{DD}	V _{p-p}
Recommended Static or Dynamic Voltage Across the Switch (Note 3) (Figure 1)	ΔV _{switch}	—	Channel On	0	600	0	—	600	0	300	mV
Output Offset Voltage	V _{OO}	—	V _{in} = 0 V, No Load	—	—	—	10	—	—	—	μV
ON Resistance	R _{on}	5.0 10 15	ΔV _{switch} ≤ 500 mV ⁽³⁾ , V _{in} = V _{IL} or V _{IH} (Control), and V _{in} = 0 to V _{DD} (Switch)	— — —	800 400 220	— — —	250 120 80	1050 500 280	— — —	1200 520 300	Ω
ΔON Resistance Between Any Two Channels in the Same Package	ΔR _{on}	5.0 10 15		— — —	70 50 45	— — —	25 10 10	70 50 45	— — —	135 95 65	Ω
Off-Channel Leakage Current (Figure 6)	I _{off}	15	V _{in} = V _{IL} or V _{IH} (Control) Channel to Channel or Any One Channel	—	±100	—	±0.05	±100	—	±1000	nA
Capacitance, Switch I/O	C _{I/O}	—	Switch Off	—	—	—	10	15	—	—	pF
Capacitance, Feedthrough (Switch Off)	C _{I/O}	—		—	—	—	0.47	—	—	—	pF

Product parametric performance is indicated in the Electrical Characteristics for the listed test conditions, unless otherwise noted. Product performance may not be indicated by the Electrical Characteristics if operated under different conditions.

2. Data labeled "Typ" is not to be used for design purposes, but is intended as an indication of the IC's potential performance.

3. For voltage drops across the switch (ΔV_{switch}) > 600 mV (> 300 mV at high temperature), excessive V_{DD} current may be drawn; i.e. the current out of the switch may contain both V_{DD} and switch input components. The reliability of the device will be unaffected unless the Maximum Ratings are exceeded. (See first page of this data sheet.)

MC14066B

ELECTRICAL CHARACTERISTICS (Note 4) ($C_L = 50$ pF, $T_A = 25^\circ\text{C}$ unless otherwise noted.)

Characteristic	Symbol	V _{DD} Vdc	Min	Typ (Note 5)	Max	Unit
Propagation Delay Times Input to Output ($R_L = 10$ k Ω) $t_{PLH}, t_{PHL} = (0.17 \text{ ns/pF}) C_L + 15.5 \text{ ns}$ $t_{PLH}, t_{PHL} = (0.08 \text{ ns/pF}) C_L + 6.0 \text{ ns}$ $t_{PLH}, t_{PHL} = (0.06 \text{ ns/pF}) C_L + 4.0 \text{ ns}$	t_{PLH}, t_{PHL}					ns
Control to Output ($R_L = 1$ k Ω) (Figure 2) Output "1" to High Impedance	t_{PHZ}	5.0 10 15	– – –	40 35 30	80 70 60	ns
Output "0" to High Impedance	t_{PLZ}	5.0 10 15	– – –	40 35 30	80 70 60	ns
High Impedance to Output "1"	t_{PZH}	5.0 10 15	– – –	60 20 15	120 40 30	ns
High Impedance to Output "0"	t_{PZL}	5.0 10 15	– – –	60 20 15	120 40 30	ns
Second Harmonic Distortion ($V_{in} = 1.77$ Vdc, RMS Centered @ 0.0 Vdc, $R_L = 10$ k Ω , $f = 1.0$ kHz)	–	5.0	–	0.1	–	%
Bandwidth (Switch ON) (Figure 3) ($R_L = 1$ k Ω , 20 Log (V_{out}/V_{in}) = – 3 dB, $C_L = 50$ pF, $V_{in} = 5$ V _{p-p})	–	5.0	–	65	–	MHz
Feedthrough Attenuation (Switch OFF) ($V_{in} = 5$ V _{p-p} , $R_L = 1$ k Ω , $f_{in} = 1.0$ MHz) (Figure 3)	–	5.0	–	– 50	–	dB
Channel Separation (Figure 4) ($V_{in} = 5$ V _{p-p} , $R_L = 1$ k Ω , $f_{in} = 8.0$ MHz) (Switch A ON, Switch B OFF)	–	5.0	–	– 50	–	dB
Crosstalk, Control Input to Signal Output (Figure 5) ($R_1 = 1$ k Ω , $R_L = 10$ k Ω , Control $t_{TLH} = t_{THL} = 20$ ns)	–	5.0	–	300	–	mV _{p-p}

4. The formulas given are for the typical characteristics only at 25°C.

5. Data labelled "Typ" is not to be used for design purposes but is intended as an indication of the IC's potential performance.

TEST CIRCUITS

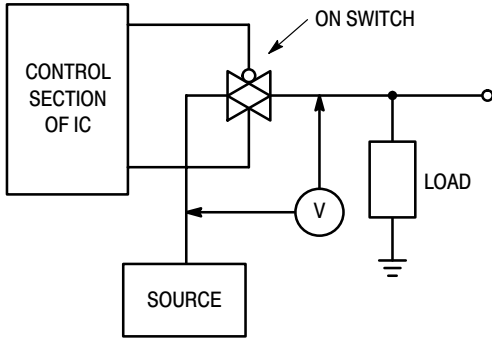

Figure 1. ΔV Across Switch

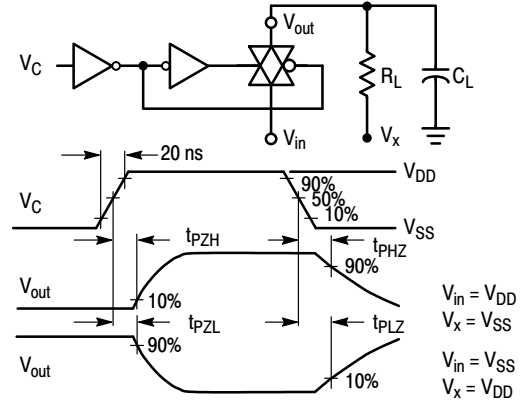

Figure 2. Turn-On Delay Time Test Circuit and Waveforms

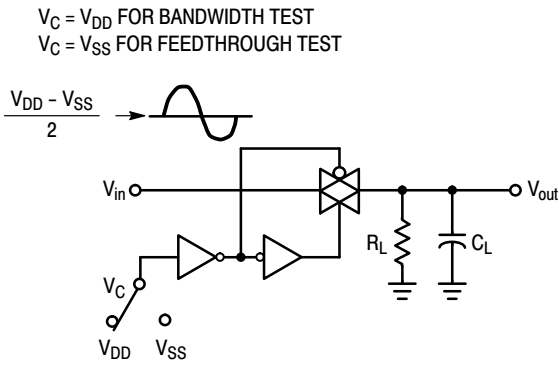

Figure 3. Bandwidth and Feedthrough Attenuation

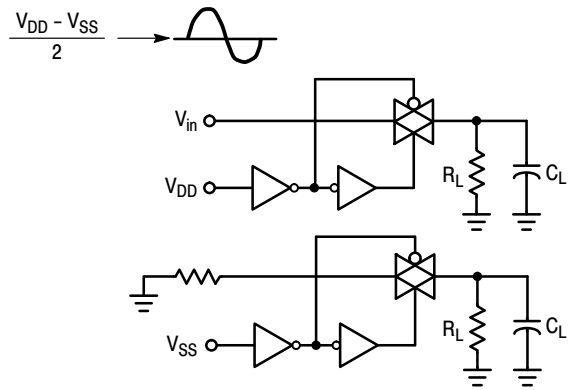

Figure 4. Channel Separation

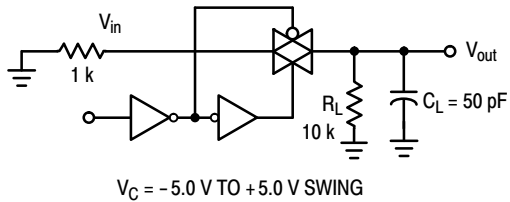

Figure 5. Crosstalk, Control to Output

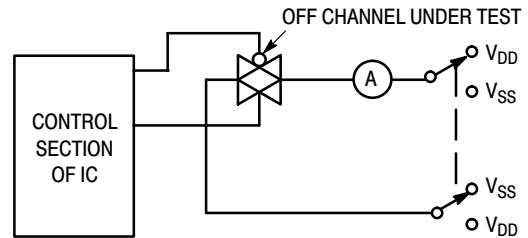

Figure 6. Off Channel Leakage

MC14066B

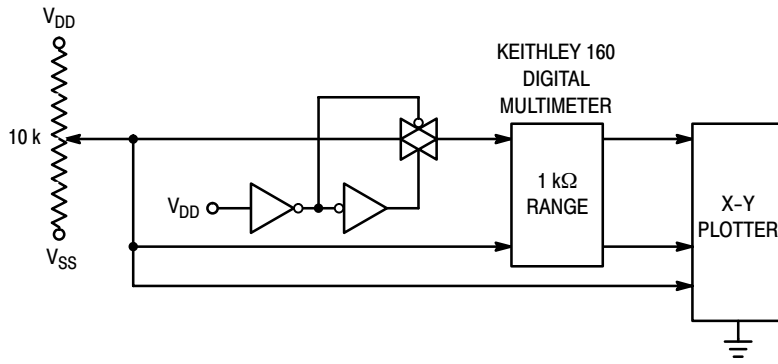

Figure 7. Channel Resistance (R_{ON}) Test Circuit

TYPICAL RESISTANCE CHARACTERISTICS

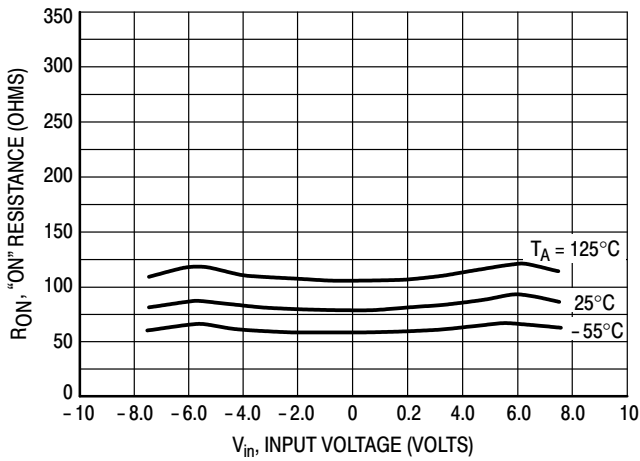

Figure 8. $V_{DD} = 7.5 \text{ V}$, $V_{SS} = -7.5 \text{ V}$

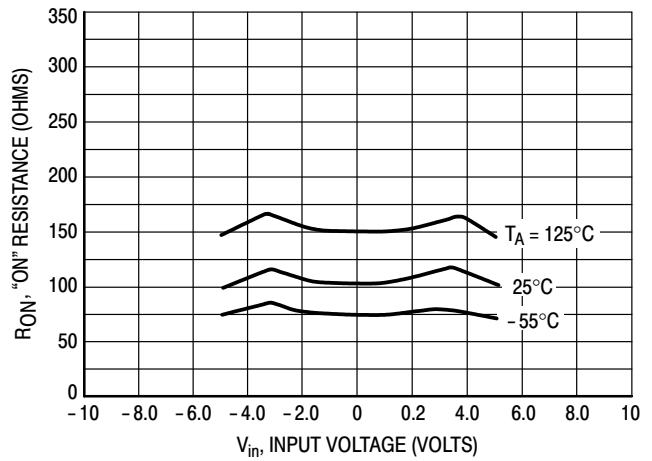

Figure 9. $V_{DD} = 5.0 \text{ V}$, $V_{SS} = -5.0 \text{ V}$

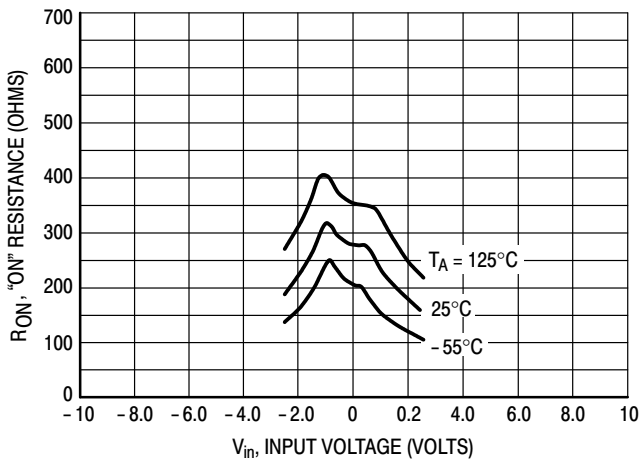

Figure 10. $V_{DD} = 2.5 \text{ V}$, $V_{SS} = -2.5 \text{ V}$

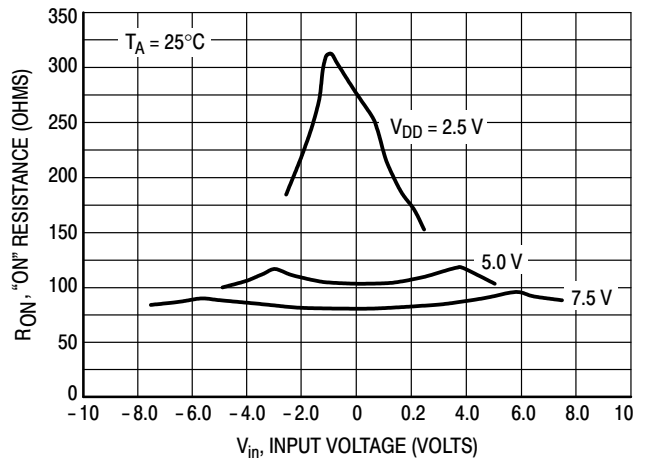

Figure 11. Comparison at 25°C , $V_{DD} = -V_{SS}$

MC14066B

APPLICATIONS INFORMATION

Figure A illustrates use of the Analog Switch. The 0-to-5 V digital control signal is used to directly control a 5 V peak-to-peak analog signal.

The digital control logic levels are determined by V_{DD} and V_{SS} . The V_{DD} voltage is the logic high voltage, the V_{SS} voltage is logic low. For the example, $V_{DD} = +5\text{ V} =$ logic high at the control inputs; $V_{SS} = \text{GND} = 0\text{ V} =$ logic low.

The maximum analog signal level is determined by V_{DD} and V_{SS} . The analog voltage must not swing higher than V_{DD} or lower than V_{SS} .

The example shows a 5 V peak-to-peak signal which allows no margin at either peak. If voltage transients above

V_{DD} and/or below V_{SS} are anticipated on the analog channels, external diodes (D_x) are recommended as shown in Figure B. These diodes should be small signal types able to absorb the maximum anticipated current surges during clipping.

The *absolute* maximum potential difference between V_{DD} and V_{SS} is 18 V. Most parameters are specified up to 15 V which is the *recommended* maximum difference between V_{DD} and V_{SS} .

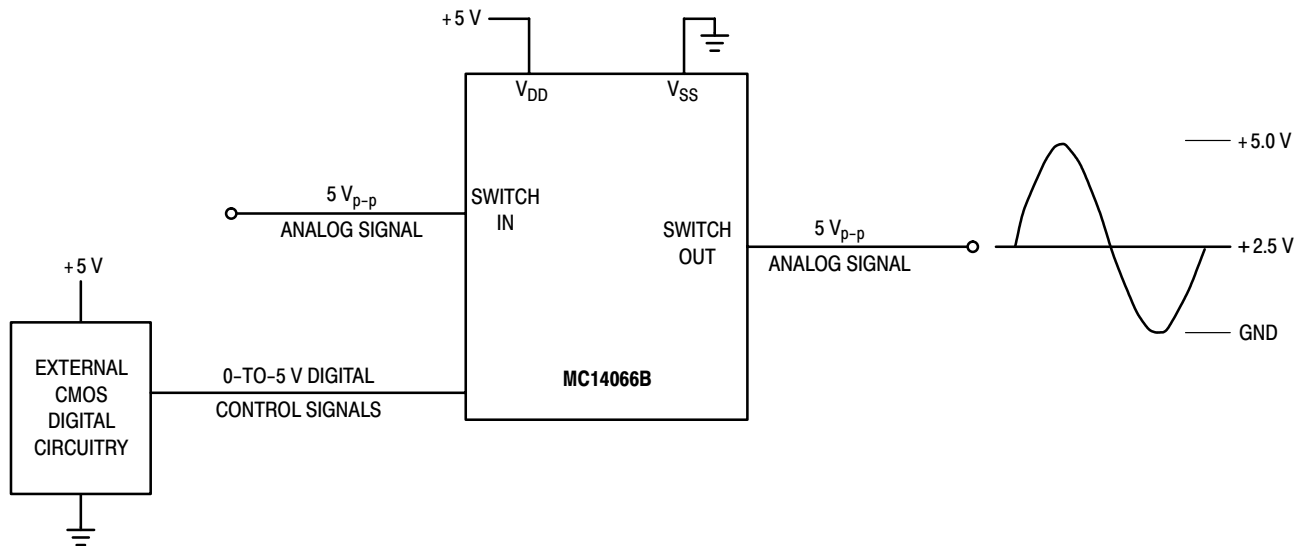

Figure A. Application Example

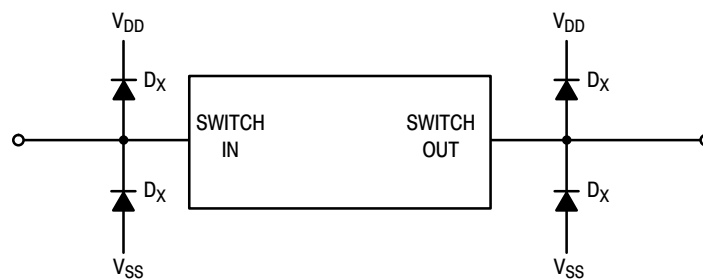

Figure B. External Germanium or Schottky Clipping Diodes

MC14066B

ORDERING INFORMATION

Device	Package	Shipping†
MC14066BDG	SOIC-14 (Pb-Free)	55 Units / Rail
NLV14066BDG*	SOIC-14 (Pb-Free)	55 Units / Rail
MC14066BDR2G	SOIC-14 (Pb-Free)	2500 / Tape & Reel
NLV14066BDR2G*	SOIC-14 (Pb-Free)	2500 / Tape & Reel
MC14066BDTR2G	TSSOP-14 (Pb-Free)	2500 / Tape & Reel
NLV14066BDTR2G*	TSSOP-14 (Pb-Free)	2500 / Tape & Reel
MC14066BFELG	SOEIAJ-14 (Pb-Free)	2000 / Tape & Reel

†For information on tape and reel specifications, including part orientation and tape sizes, please refer to our Tape and Reel Packaging Specifications Brochure, BRD8011/D.

*NLV Prefix for Automotive and Other Applications Requiring Unique Site and Control Change Requirements; AEC-Q100 Qualified and PPAP Capable.

MC14066B

PACKAGE DIMENSIONS

SOIC-14 NB
CASE 751A-03
ISSUE K

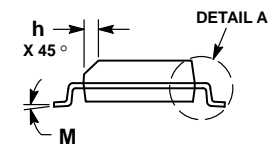
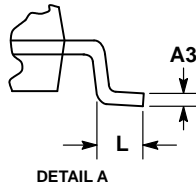
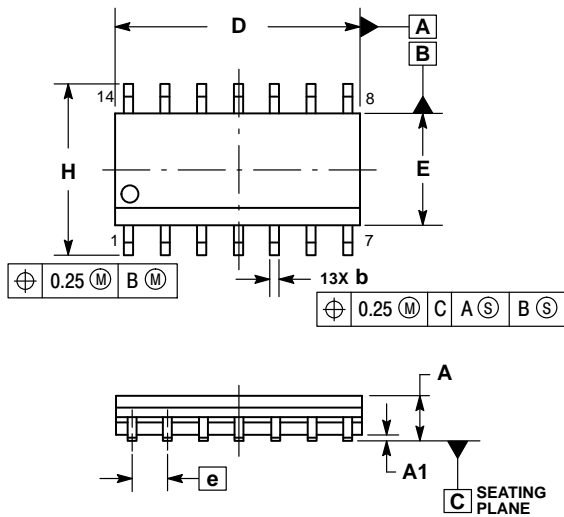

NOTES:

1. DIMENSIONING AND TOLERANCING PER ASME Y14.5M, 1994.
2. CONTROLLING DIMENSION: MILLIMETERS.
3. DIMENSION b DOES NOT INCLUDE DAMBAR PROTRUSION. ALLOWABLE PROTRUSION SHALL BE 0.13 TOTAL IN EXCESS OF AT MAXIMUM MATERIAL CONDITION.
4. DIMENSIONS D AND E DO NOT INCLUDE MOLD PROTRUSIONS.
5. MAXIMUM MOLD PROTRUSION 0.15 PER SIDE.

DIM	MILLIMETERS		INCHES	
	MIN	MAX	MIN	MAX
A	1.35	1.75	0.054	0.068
A1	0.10	0.25	0.004	0.010
A3	0.19	0.25	0.008	0.010
b	0.35	0.49	0.014	0.019
D	8.55	8.75	0.337	0.344
E	3.80	4.00	0.150	0.157
e	1.27 BSC		0.050 BSC	
H	5.80	6.20	0.228	0.244
h	0.25	0.50	0.010	0.019
L	0.40	1.25	0.016	0.049
M	0°	7°	0°	7°

SOLDERING FOOTPRINT*

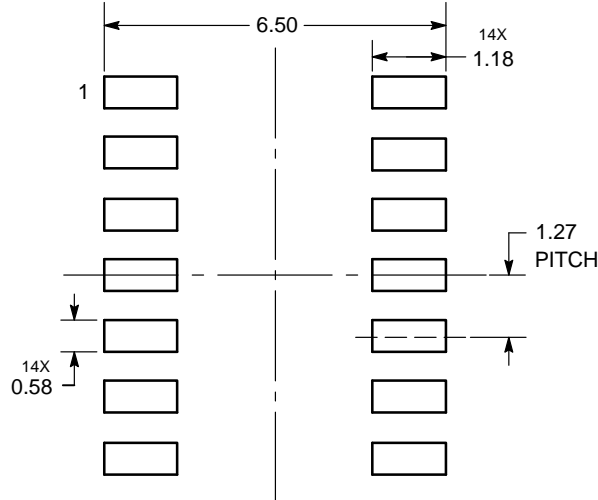

DIMENSIONS: MILLIMETERS

*For additional information on our Pb-Free strategy and soldering details, please download the ON Semiconductor Soldering and Mounting Techniques Reference Manual, SOLDERRM/D.

MC14066B

PACKAGE DIMENSIONS

TSSOP-14
CASE 948G
ISSUE B

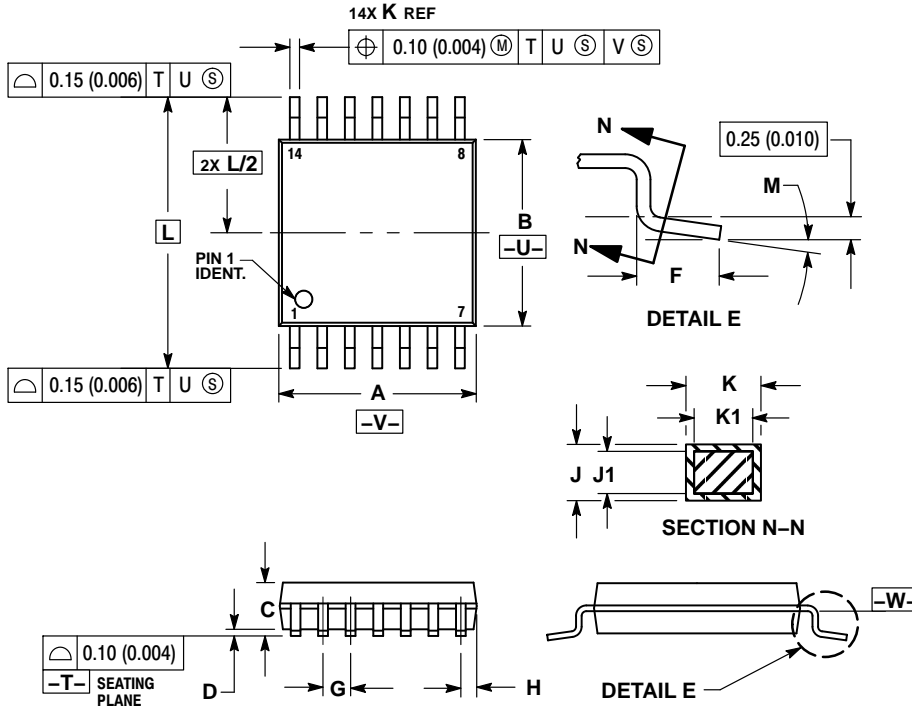

NOTES:

1. DIMENSIONING AND TOLERANCING PER ANSI Y14.5M, 1982.
2. CONTROLLING DIMENSION: MILLIMETER.
3. DIMENSION A DOES NOT INCLUDE MOLD FLASH, PROTRUSIONS OR GATE BURRS. MOLD FLASH OR GATE BURRS SHALL NOT EXCEED 0.15 (0.006) PER SIDE.
4. DIMENSION B DOES NOT INCLUDE INTERLEAD FLASH OR PROTRUSION. INTERLEAD FLASH OR PROTRUSION SHALL NOT EXCEED 0.25 (0.010) PER SIDE.
5. DIMENSION K DOES NOT INCLUDE DAMBAR PROTRUSION. ALLOWABLE DAMBAR PROTRUSION SHALL BE 0.08 (0.003) TOTAL IN EXCESS OF THE K DIMENSION AT MAXIMUM MATERIAL CONDITION.
6. TERMINAL NUMBERS ARE SHOWN FOR REFERENCE ONLY.
7. DIMENSION A AND B ARE TO BE DETERMINED AT DATUM PLANE -W-.

DIM	MILLIMETERS		INCHES	
	MIN	MAX	MIN	MAX
A	4.90	5.10	0.193	0.200
B	4.30	4.50	0.169	0.177
C	---	1.20	---	0.047
D	0.05	0.15	0.002	0.006
F	0.50	0.75	0.020	0.030
G	0.65 BSC		0.026 BSC	
H	0.50	0.60	0.020	0.024
J	0.09	0.20	0.004	0.008
J1	0.09	0.16	0.004	0.006
K	0.19	0.30	0.007	0.012
K1	0.19	0.25	0.007	0.010
L	6.40 BSC		0.252 BSC	
M	0° - 8°		0° - 8°	

SOLDERING FOOTPRINT*

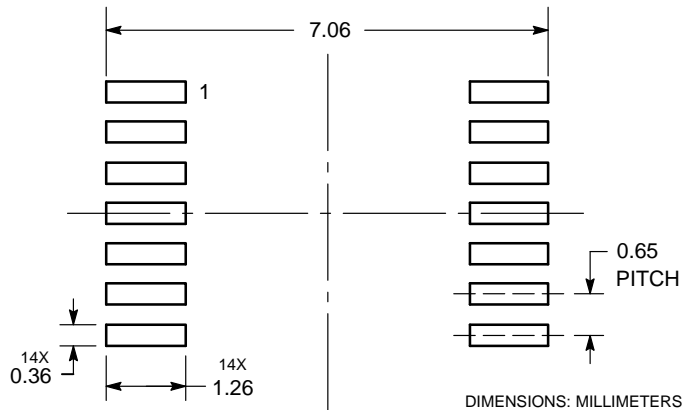

*For additional information on our Pb-Free strategy and soldering details, please download the ON Semiconductor Soldering and Mounting Techniques Reference Manual, SOLDERRM/D.

MC14066B

PACKAGE DIMENSIONS

SOEIAJ-14
CASE 965
ISSUE B

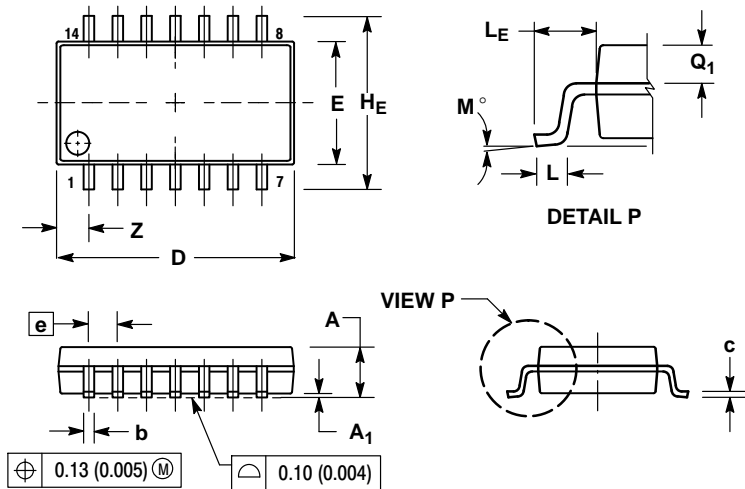

NOTES:

1. DIMENSIONING AND TOLERANCING PER ANSI Y14.5M, 1982.
2. CONTROLLING DIMENSION: MILLIMETER.
3. DIMENSIONS D AND E DO NOT INCLUDE MOLD FLASH OR PROTRUSIONS AND ARE MEASURED AT THE PARTING LINE. MOLD FLASH OR PROTRUSIONS SHALL NOT EXCEED 0.15 (0.006) PER SIDE.
4. TERMINAL NUMBERS ARE SHOWN FOR REFERENCE ONLY.
5. THE LEAD WIDTH DIMENSION (b) DOES NOT INCLUDE DAMBAR PROTRUSION. ALLOWABLE DAMBAR PROTRUSION SHALL BE 0.08 (0.003) TOTAL IN EXCESS OF THE LEAD WIDTH DIMENSION AT MAXIMUM MATERIAL CONDITION. DAMBAR CANNOT BE LOCATED ON THE LOWER RADIUS OR THE FOOT. MINIMUM SPACE BETWEEN PROTRUSIONS AND ADJACENT LEAD TO BE 0.46 (0.018).

DIM	MILLIMETERS		INCHES	
	MIN	MAX	MIN	MAX
A	---	2.05	---	0.081
A ₁	0.05	0.20	0.002	0.008
b	0.35	0.50	0.014	0.020
c	0.10	0.20	0.004	0.008
D	9.90	10.50	0.390	0.413
E	5.10	5.45	0.201	0.215
e	1.27 BSC		0.050 BSC	
HE	7.40	8.20	0.291	0.323
L	0.50	0.85	0.020	0.033
LE	1.10	1.50	0.043	0.059
M	0°	10°	0°	10°
Q ₁	0.70	0.90	0.028	0.035
Z	---	1.42	---	0.056

ON Semiconductor and the  are registered trademarks of Semiconductor Components Industries, LLC (SCILLC) or its subsidiaries in the United States and/or other countries. SCILLC owns the rights to a number of patents, trademarks, copyrights, trade secrets, and other intellectual property. A listing of SCILLC's product/patent coverage may be accessed at www.onsemi.com/site/pdf/Patent-Marking.pdf. SCILLC reserves the right to make changes without further notice to any products herein. SCILLC makes no warranty, representation or guarantee regarding the suitability of its products for any particular purpose, nor does SCILLC assume any liability arising out of the application or use of any product or circuit, and specifically disclaims any and all liability, including without limitation special, consequential or incidental damages. "Typical" parameters which may be provided in SCILLC data sheets and/or specifications can and do vary in different applications and actual performance may vary over time. All operating parameters, including "Typicals" must be validated for each customer application by customer's technical experts. SCILLC does not convey any license under its patent rights nor the rights of others. SCILLC products are not designed, intended, or authorized for use as components in systems intended for surgical implant into the body, or other applications intended to support or sustain life, or for any other application in which the failure of the SCILLC product could create a situation where personal injury or death may occur. Should Buyer purchase or use SCILLC products for any such unintended or unauthorized application, Buyer shall indemnify and hold SCILLC and its officers, employees, subsidiaries, affiliates, and distributors harmless against all claims, costs, damages, and expenses, and reasonable attorney fees arising out of, directly or indirectly, any claim of personal injury or death associated with such unintended or unauthorized use, even if such claim alleges that SCILLC was negligent regarding the design or manufacture of the part. SCILLC is an Equal Opportunity/Affirmative Action Employer. This literature is subject to all applicable copyright laws and is not for resale in any manner.

PUBLICATION ORDERING INFORMATION

LITERATURE FULFILLMENT:

Literature Distribution Center for ON Semiconductor
P.O. Box 5163, Denver, Colorado 80217 USA
Phone: 303-675-2175 or 800-344-3860 Toll Free USA/Canada
Fax: 303-675-2176 or 800-344-3867 Toll Free USA/Canada
Email: orderlit@onsemi.com

N. American Technical Support: 800-282-9855 Toll Free
USA/Canada
Europe, Middle East and Africa Technical Support:
Phone: 421 33 790 2910
Japan Customer Focus Center
Phone: 81-3-5817-1050

ON Semiconductor Website: www.onsemi.com

Order Literature: <http://www.onsemi.com/orderlit>

For additional information, please contact your local Sales Representative

Looking for pricing, stock, or lifecycle information?

Click below to explore more details on WIN SOURCE:

 [View 14066B](#) on WIN SOURCE

 [ON Semiconductor](#) Information

Optimize Your Supply Chain with WIN SOURCE Solutions

-  Global Sourcing Solution
-  Obsolete Management
-  Cost Control Management
-  Shortage Management
-  Alternative Solution
-  Excess Inventory Management