

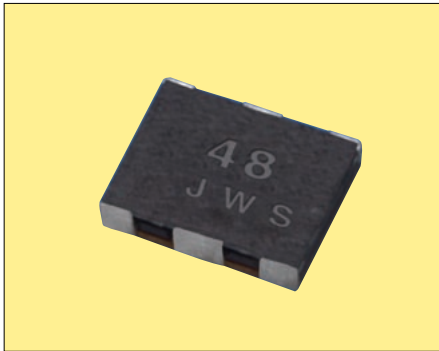

**THE DATASHEET OF
PBRC16.00HR70X000**





RoHS Compliant

Ultra-miniature chip resonator with 0.8mm maximum height
 Best suited for compact and low profile electronic devices

Features

- Ultra-miniature (2.5×2.0×0.8mm) SMD type
- High precision type is available for full speed USB

Applications

- CD-R/W
- HDD
- DVD-ROM
- MD
- Printer
- Cellular (CDMA/PCS)
- Portable Electronic Equipment
- Memory Card
- USB

How to Order

PRTC 25.00 T R 50 10 W 000
 ① ② ③ ④ ⑤ ⑥ ⑦ ⑧

- ① Series
- ② Oscillating Frequency (MHz)
- ③ Oscillating Mode
- ④ Packaging : Tape & Reel
4000pcs./Reel
- ⑤ Initial Frequency Tolerance (0.5%)
- ⑥ Load Capacitance
- ⑦ Operating Temperature (-20°C to 80°C)
- ⑧ Unique Code

Notice

- Non Washable

Dimensions

(Unit : mm)

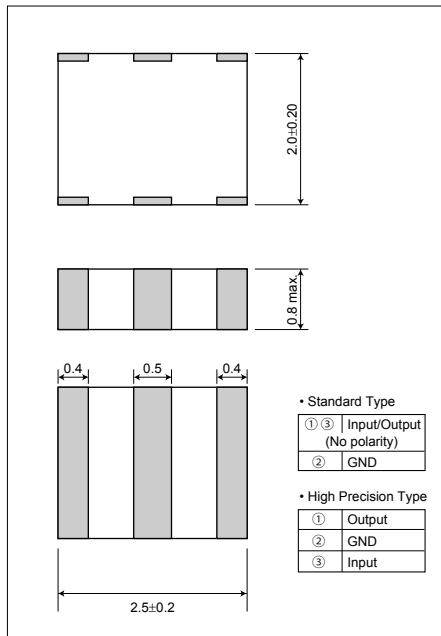

Test Circuit

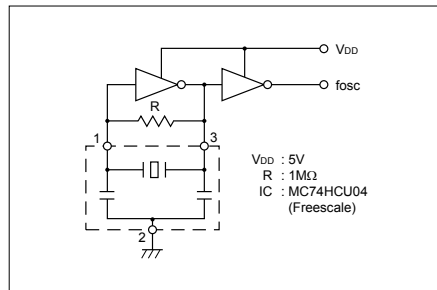

Specifications

• Standard Type

Frequency Range	Frequency Tolerance (25°C)	Temperature Stability (-20 to 80°C)	IC	Standard Frequency (MHz)
25.0 to 60.0MHz	±0.5%	±0.2%	MC74HCU04 (Freescale)	25.0, 30.0, 33.86, 40.0

Please contact your local sales office for IC matching.

• High Precision Type

Frequency Range	Frequency Tolerance (25°C)	Temperature Stability (-20 to 70°C)	Aging (10 years)	IC	Standard Frequency (MHz)
25.0 to 60.0MHz	±0.16%	±0.08%	±0.01%	MC74HCU04 (Freescale)	48.0

Recommended Land Pattern (Unit : mm)

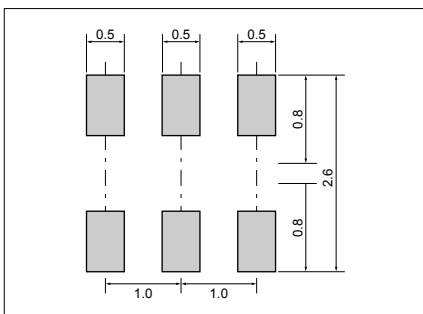

Recommended Reflow Profile

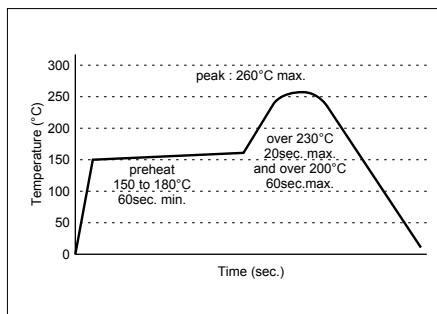

Packaging : Taping

(Unit : mm)

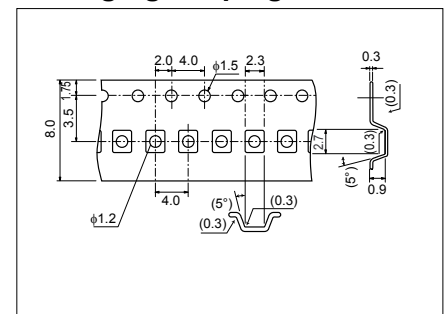



RoHS Compliant

Features

- Miniature size (3.2×2.1×1.5 mm)
- Wide frequency range
- High precision type is available for full speed USB

Applications

- CD-ROM
- HDD
- DVD-ROM
- MD
- Printer
- Cellular (CDMA/PCS)
- Portable Electronic Equipment
- USB

How to Order

SSR 33.86 B R
① ② ③ ④

- ① Series
- ② Oscillating Frequency (MHz)
- ③ Type B: 3rd-Overtone Mode Built-in Capacitor
F: Fundamental Mode Built-in Capacitor
- ④ Packaging : Tape & Reel
2000pcs./Reel

Notice

- Non Washable
- Operating Temperature -20°C to +80°C

Dimensions

(Unit : mm)

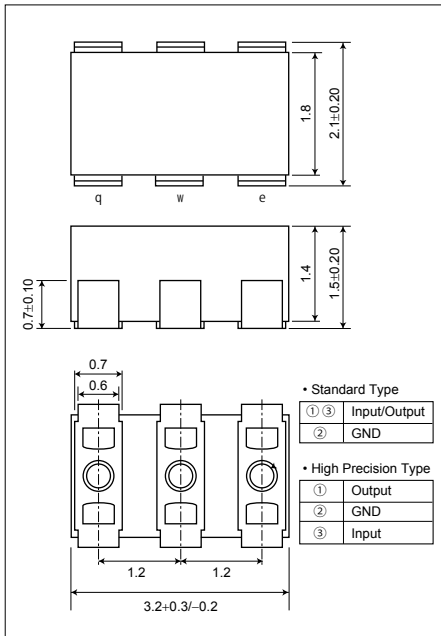

Test Circuit

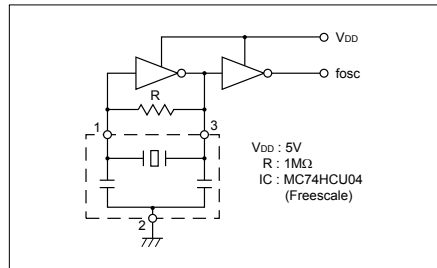

Specifications

• Standard Type

	Frequency Range	Frequency Tolerance (25°C)	Temperature Stability (-20 to 80°C)	IC	Main Frequency (MHz)
B	16.0 to 60.0MHz (3rd-overtone)	±0.5%	±0.3%	MC74HCU04 (Freescale)	16.93, 20.0, 27.0, 33.86, 50.8
F	16.0 to 20.0MHz (Fundamental)				16.93

Please contact your local AVX office for IC matching.

• High Precision Type

	Frequency Range	Frequency Tolerance (25°C)	Temperature Stability (-20 to 70°C)	Aging (10 years)	IC	Main Frequency (MHz)
B	16.0 to 60.0MHz (3rd-overtone)	±0.18% (Option ±0.08%)	±0.06%	±0.01%	MC74HCU04 (Freescale)	48.0

Recommended Land Pattern

(Unit : mm)

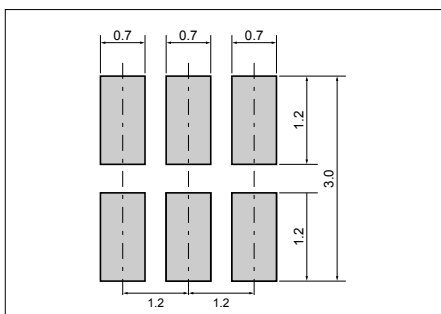

Recommended Reflow Profile

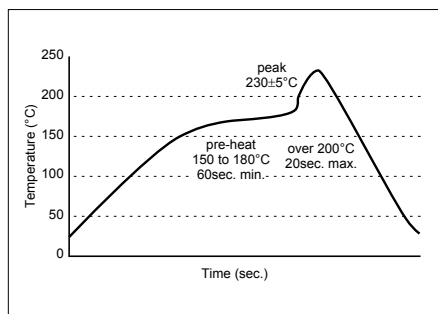

Packaging : Taping

(Unit : mm)

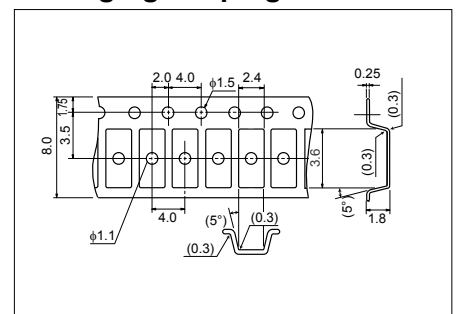



RoHS Compliant

Features

- High reliability, high temperature withstanding ceramic case
- Rectangular shape allows easy pick and placement
- Small & low profile
- Reflow solderable
- Excellent solderability (Nickel barrier+Au flash terminations)

How to Order

PBRC 15.00 G R 50 Y 000
 ① ② ③ ④ ⑤ ⑥ ⑦

- ① Series
- ② Frequency (MHz)
- ③ Type (G,L)
- ④ Packing _ Bulk (Null)
 R Reel (G: 2k/reel, L: 3k/reel)
- ⑤ Frequency Tolerance at 25°C

10	±0.1%	20	±0.2%
30	±0.3%	40	±0.4%
50	±0.5%	70	±0.7%

- ⑥ Operating Temperature

X	-40°C to 85°C	Y	-40°C to 125°C
Z	-40°C to 150°C		

- ⑦ Unique Code

Specifications

Series	Frequency Range(MHz)	Frequency Tolerance(25°C)	Temperature Stability
PBRC-G	2.00 to 8.00	±0.5% (op. ±0.3%)	±0.5% (-40 to 85°C)
	8.01 to 20.0	±0.7% (op. ±0.5%)	±0.1% (-40 to 85°C)
PBRC-L	4.00 to 8.00	±0.5% (op. ±0.3%)	±0.5% (-40 to 85°C)
	8.01 to 20.0	±0.7% (op. ±0.5%)	±0.1% (-40 to 85°C)

* Aging for 10 years is within ±0.3% from the initial frequency at 25°C.

Test Circuit

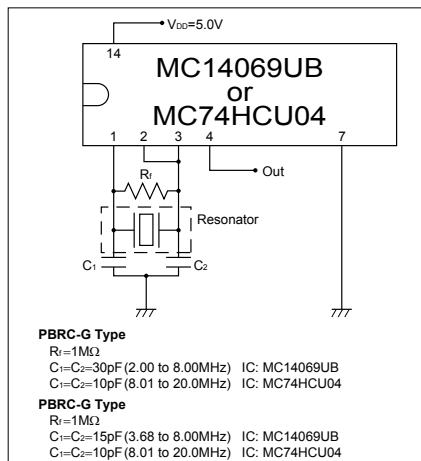

Note)

- Values of C1, C2 and Rf are evaluated with IC, MC14069UB, and evaluation of circuit is necessary when using other IC's.
- IC circuit matching may be referenced with
 1) IC data books
 2) List of Recommended circuits in Kyocera website.
- Please contact IC manufacturer or Kyocera when there are difficulties in finding recommended circuits.

Dimensions

(Unit : mm)

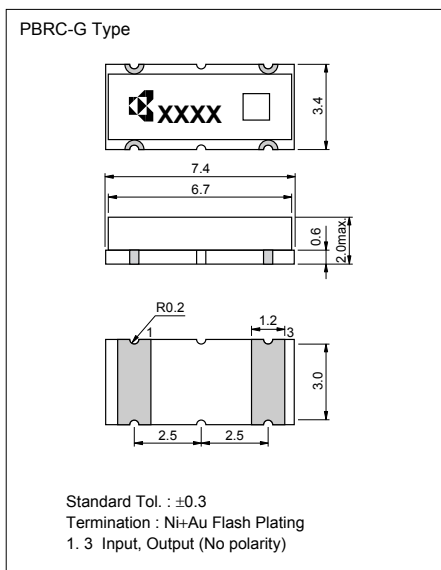

(Unit : mm)

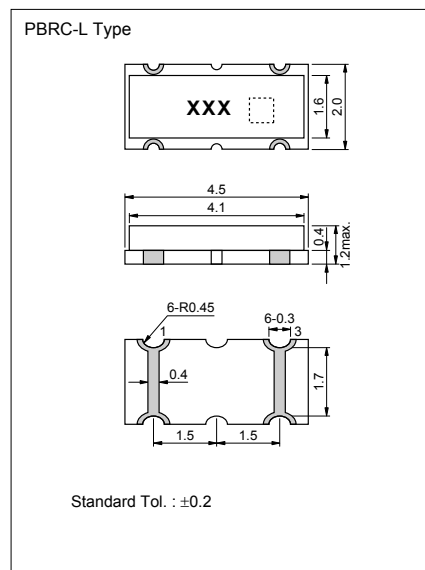



RoHS Compliant

Features

- High reliability, high temperature withstanding ceramic case
- Rectangular shape allows easy pick and placement
- Small & low profile
- Reflow solderable
- Excellent solderability (Nickel barrier+Au flash terminations)

How to Order (PBRC-H, PBRC-M)

PBRC 15.00 H R 50 Y 000
① ② ③ ④ ⑤ ⑥ ⑦

- ① Series
- ② Frequency (MHz)
- ③ Type (H, M)
- ④ Packing _ Bulk (Null) R Reel (H: 2k/reel, M: 3k/reel)
- ⑤ Frequency Tolerance at 25°C

10	±0.1%	20	±0.2%
30	±0.3%	40	±0.4%
50	±0.5%	70	±0.7%

- ⑥ Operating Temperature

X	-40°C to 85°C	Y	-40°C to 125°C
Z	-40°C to 150°C		

- ⑦ Unique Code

How to Order (PRQC)

PRQC 8.00 S R 50 10 X 000
① ② ③ ④ ⑤ ⑥ ⑦ ⑧

- ① Series
- ② Frequency (MHz)
- ③ Type (S)
- ④ Packing _ Bulk (Null) R Reel (3k/reel)
- ⑤ Frequency Tolerance at 25°C

10	±0.1%	20	±0.2%
30	±0.3%	40	±0.4%
50	±0.5%	70	±0.7%

- ⑥ Built-in Capacitance 10pF : 10

- ⑦ Operating Temperature

W	-20°C to 80°C	Y	-40°C to 125°C
X	-40°C to 85°C	Z	-40°C to 150°C

- ⑧ Unique Code

Specifications

Series	Frequency Range(MHz)	Frequency Tolerance(25°C)	Temperature Stability
PBRC-H	2.00 to 8.00	±0.5% (op. ±0.3%)	±0.5% (-40 to 85°C)
	8.01 to 20.0	±0.7% (op. ±0.5%)	±0.1% (-40 to 85°C)
PBRC-M	4.00 to 8.00	±0.5% (op. ±0.3%)	±0.5% (-40 to 85°C)
	8.01 to 20.0	±0.7% (op. ±0.5%)	±0.1% (-40 to 85°C)
PRQC	8.00 to 20.0	±0.5% (op. ±0.3%)	±0.5% (-40 to 85°C)

* Aging for 10 years is within ±0.3% from the initial frequency at 25°C.

Test Circuit

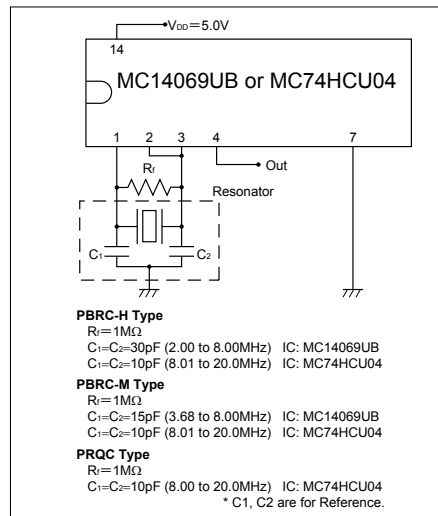

Note)

- This product includes built-in capacitors, but values may not be the most appropriate depending on IC's.
- Evaluation of circuit with IC is necessary. IC circuit matching may be referenced with
 - 1) IC data books
 - 2) List of Recommended circuits in Kyocera website.
- Please contact IC manufacturer or Kyocera when there are difficulties in finding recommended circuits.

Dimensions

(Unit : mm)

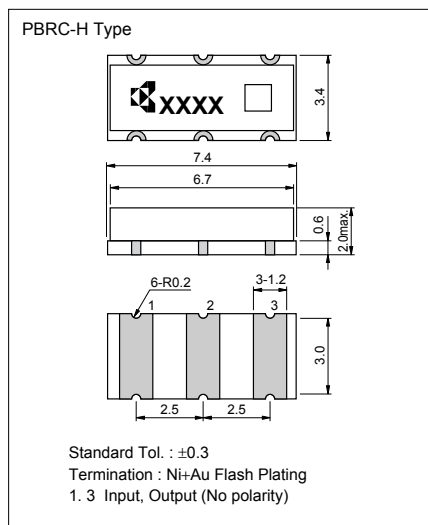

(Unit : mm)

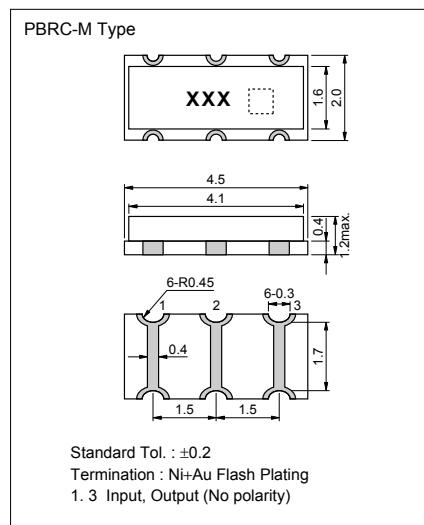

(Unit : mm)

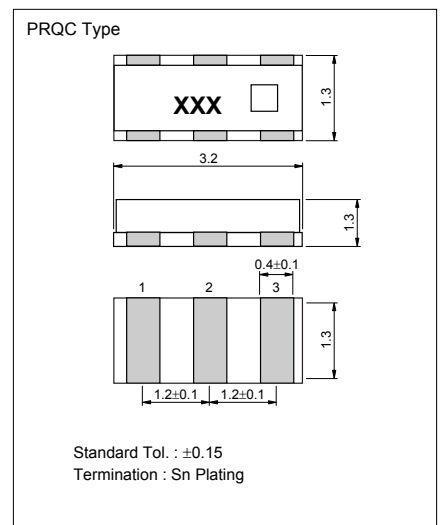

#	Pin #
1	Input
2	Ground
3	Output

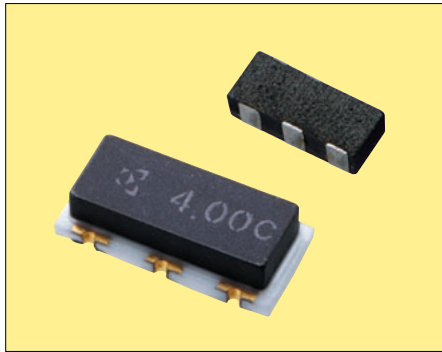

RoHS Compliant

Features

- Miniature & low profile
- Rectangular shape allows easy pick and placement
- Component cost and space saving
- High density mounting possible
- Reflow solderable & washable
- High reliability, high temperature operating with ceramic case

Applications

- Automotive
- ABS
- ECU
- Air-Bag System

How to Order (PBRV-H,PBRV-M)

PBRV 15.00 H R 50 Y 000
① ② ③ ④ ⑤ ⑥ ⑦

- ① Series (PBRV: Automotive)
- ② Frequency (MHz)
- ③ Type (H,M)
- ④ Packing _ Bulk (Null) R Reel (H: 2k/reel, M: 3k/reel)
- ⑤ Frequency Tolerance at 25°C

10	±0.1%	20	±0.2%
30	±0.3%	40	±0.4%
50	±0.5%	70	±0.7%

- ⑥ Operating Temperature

X	-40°C to 85°C	Y	-40°C to 125°C
Z	-40°C to 150°C		

- ⑦ Unique Code

How to Order (PRQV)

PRQV 8.00 S R 50 10 Y 000
① ② ③ ④ ⑤ ⑥ ⑦ ⑧

- ① Series (PRQV: Automotive)
- ② Frequency (MHz)
- ③ Type (S)
- ④ Packing _ Bulk (Null) R Reel (3k/reel)
- ⑤ Frequency Tolerance at 25°C

10	±0.1%	20	±0.2%
30	±0.3%	40	±0.4%
50	±0.5%	70	±0.7%

- ⑥ Built-in Capacitance 10pF : 10

- ⑦ Operating Temperature

X	-40°C to 85°C	Y	-40°C to 125°C
Z	-40°C to 150°C		

- ⑧ Unique Code

Specifications

Series	Frequency Range(MHz)	Frequency Tolerance(25°C)	Temperature Stability
PBRV-H	4.00 to 8.00	±0.5% (op. ±0.3%)	Y: ±0.5%(-40 to +125°C) Z: ±0.5%(-40 to +150°C)
PBRV-M	8.01 to 20.00	±0.7% (op. ±0.5%)	Y: ±0.1%(-40 to +125°C) Z: ±0.2%(-40 to +150°C)
PRQV	8.00 to 20.00	±0.5% (op. ±0.3%)	Y: ±0.5%(-40 to +125°C) Z: ±0.5%(-40 to +150°C)

* Aging for 10 years is within ±0.3% from the initial frequency at 25°C.

* Please contact us for products without built-in capacitors.

Note)

- This product includes built-in capacitors, but values may not be the most appropriate depending on IC's.
- Evaluation of circuit with IC is necessary. IC circuit matching may be referenced with
 - 1) IC data books
 - 2) List of Recommended circuits in Kyocera website.
- Please contact IC manufacturer or Kyocera when there are difficulties in finding recommended circuits.

Test Circuit

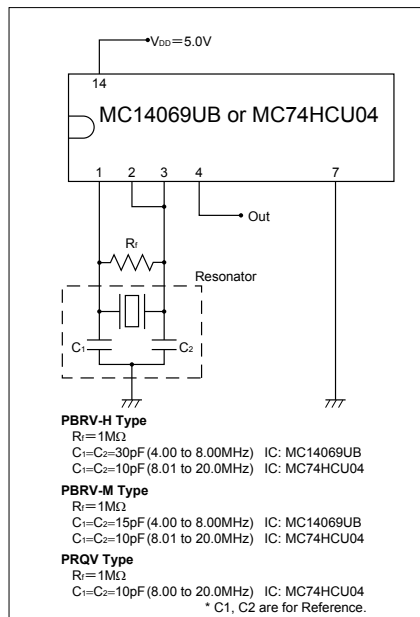

Dimensions

(Unit : mm)

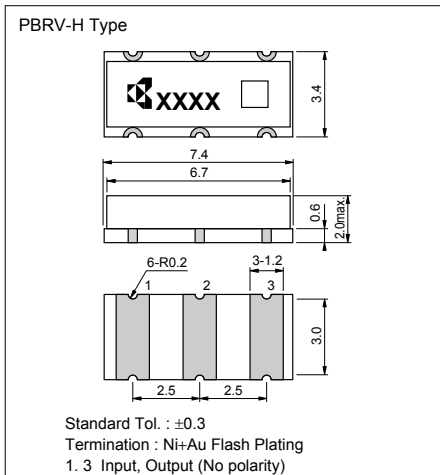

#	Pin #
1	Input
2	Ground
3	Output

(Unit : mm)

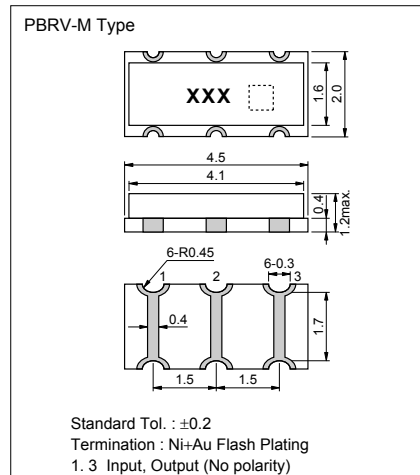

(Unit : mm)

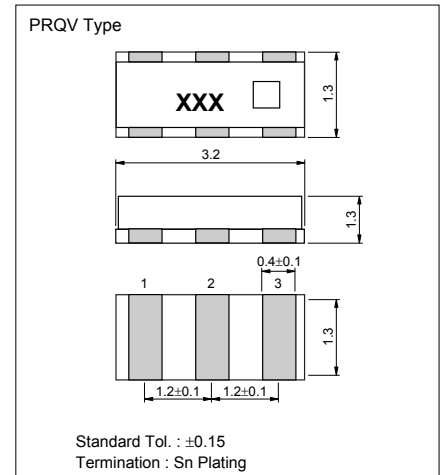



RoHS Compliant

Features

- Improved frequency tolerance for CANBUS application of automotive

How to Order (PBRV)

PBRV 15.00 H R 10 Y 000
① ② ③ ④ ⑤ ⑥ ⑦

- Series (PBRV: Automotive)
- Frequency (MHz)
- Type (H,M)
- Packing _ Bulk (Null)
R Reel (H: 2k/reel, M: 3k/reel)
- Frequency Tolerance at 25°C
10 ±0.1%
- Operating Temperature
X -40°C to 85°C **Y** -40°C to 125°C
Z -40°C to 150°C
- Unique Code

How to Order (PRQV)

PRQV 8.00 S R 10 10 Y 000
① ② ③ ④ ⑤ ⑥ ⑦ ⑧

- Series (PRQV: Automotive)
- Frequency (MHz)
- Type (S)
- Packing _ Bulk (Null)
R Reel (3k/reel)
- Frequency Tolerance at 25°C
10 ±0.1%
- Built-in Capacitance 10pF : 10
- Operating Temperature
X -40°C to 85°C **Y** -40°C to 125°C
Z -40°C to 150°C
- Unique Code

Specifications

Series	PBRV-HR/MR	PBRV-HR/MR	PRQV-S
Part Number	PBRV-HR/MR 10Y□□□	PBRV-HR/MR 10Y□□□	PRQV-SR□10Y□□□
Operating Temperature Range	-40 to +125°C	-40 to +125°C	-40 to +125°C
Frequency Range	4.0 to 7.9MHz	8.0 to 20.0MHz	8.0 to 20.0MHz
Frequency Tolerance	Initial+Temperature	±0.2%	±0.25%
	Aging	±0.1%	±0.05%
Total Frequency Tolerance	±0.4%	±0.3%	±0.3%

* Please refer to the specification sheet of each product for information including detail dimensions.

* Aging characteristics is specified at 25°C, and for the period of 10 years.

Dimensions

(Unit : mm)

(Unit : mm)

(Unit : mm)

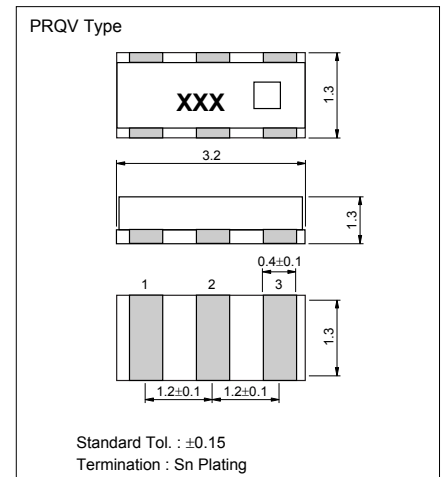
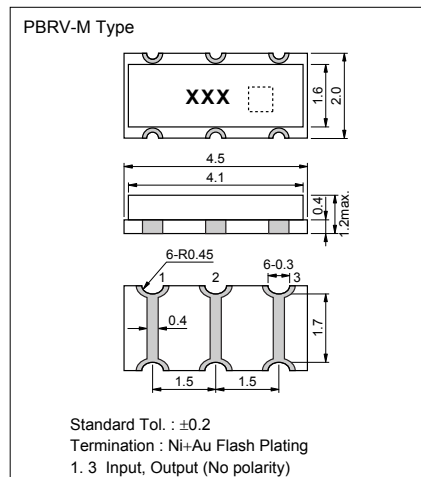
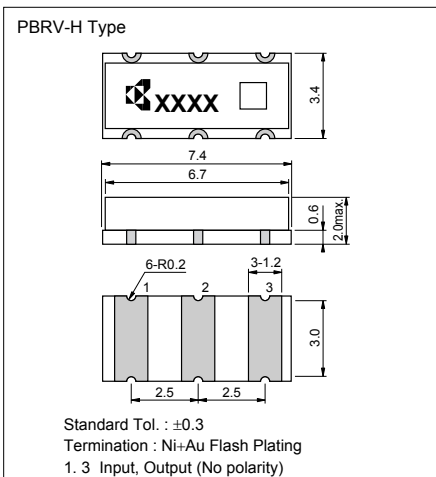

#	Pin #
1	Input
2	Ground
3	Output



Recommended Land Pattern

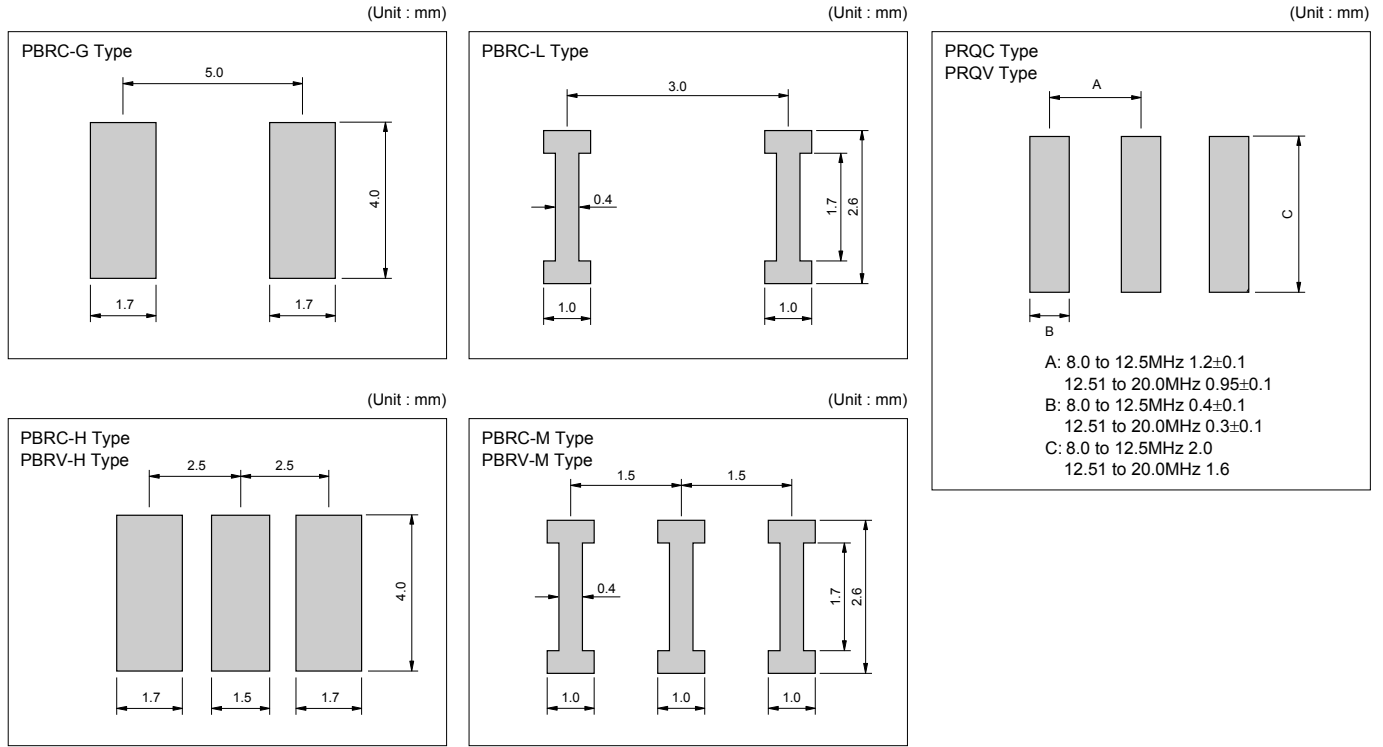

Packaging

Reel



Taping

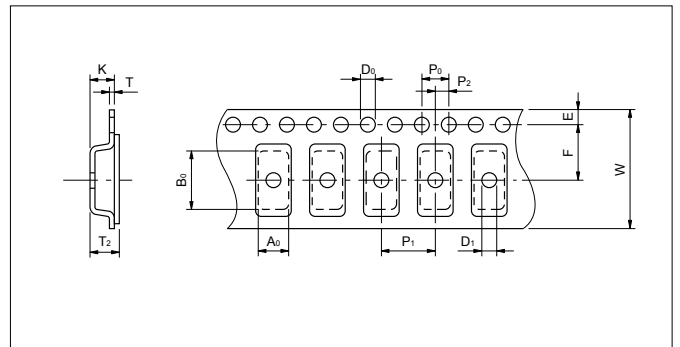

Code	A	N	W ₁	W ₂	C	D	E
7.4×3.4×2.0mm	250±2.0	80±2.0	16.5 ^{+0.1} _{-0.0}	23.6max.	13.0±0.5	21.0±0.8	2.0±0.5
4.5×2.0×1.2mm	180 ⁺⁰ ₋₃	60 ⁺¹ ₋₀	13.0±0.3	15.4±1	13.0±0.2	21.0±0.8	2.0±0.5
3.2×1.3×1.3mm	180±2	60 ⁺¹ ₋₀	9.0 ^{+0.0} _{-0.0}	140min.	13.0±0.2	21.0±0.8	2.0±0.5

Code	A ₀	B ₀	W	F	E	P ₁	P ₂	P ₀	D ₀	D ₁	T	T ₂	K
7.4×3.4×2.0mm	3.80±0.1	7.80±0.1	16.00±0.3	7.50±0.1	1.75±0.1	8.00±0.1	2.0±0.1	4.00±0.1	1.50 ^{-0.1} _{-0.0}	1.50 ^{-0.1} _{-0.0}	0.30±0.05	2.45±0.2	2.40±0.2
4.5×2.0×1.2mm	2.20±0.1	4.70±0.1	12.00±0.2	5.5±0.05	1.75±0.1	4.00±0.1	2.0±0.05	4.00±0.1	1.50 ^{-0.1} _{-0.0}	1.0±0.1	0.30±0.05	1.85max.	1.80max.
3.2×1.3×1.3mm	1.50±0.1	3.40±0.1	8.00±0.2	3.50±0.05	1.75±0.1	4.00±0.1	2.0±0.05	4.00±0.1	1.50 ^{-0.1} _{-0.0}	1.0 ^{+0.2} _{-0.0}	0.25±0.05	1.30max.	0.90±0.1

* 7.4×3.4×2.0mm=PBRC-G, PBRC-H, PBRV-G, PBRV-H 2000pcs./Reel
 4.5×2.0×1.2mm=PBRC-L, PBRC-M, PBRV-L, PBRV-M 3000pcs./Reel
 3.2×1.3×1.3mm=PRQC-S, PRQV-S 3000pcs./Reel

Looking for pricing, stock, or lifecycle information?

Click below to explore more details on WIN SOURCE:

- ⊖ [View PBRC16.00HR70X000 on WIN SOURCE](#)
- ⊖ [Kyocera Kinseki Corpotation Information](#)

Optimize Your Supply Chain with WIN SOURCE Solutions

- ✓ Global Sourcing Solution
- ✓ Obsolete Management
- ✓ Cost Control Management
- ✓ Shortage Management
- ✓ Alternative Solution
- ✓ Excess Inventory Management