



**THE DATASHEET OF
TPS1HB08FQPWPRQ1**



TPS1HB08-Q1 40-V, 8-mΩ Single-Channel Smart High-Side Switch

1 Features

- AEC-Q100 qualified for automotive applications
 - Temperature grade 1: –40°C to 125°C
 - Device HBM ESD classification level 2
 - Device CDM ESD classification level C4B
 - Withstands 40-V load dump
- [Functional safety capable](#)
 - Documentation available to aid functional safety system design
- Single-channel smart high-side switch with 8-mΩ R_{ON} ($T_J = 25^\circ\text{C}$)
- Improve system level reliability through [adjustable current limiting](#)
 - Current limit set-point from 6.4 A to 70 A
 - Version F: 94 A fixed I_{LIM}
- Robust integrated output protection:
 - Integrated thermal protection
 - Protection against short to ground and battery
 - Protection against [reverse battery](#) events including automatic switch on of FET with reverse voltage
 - Automatic shut off on loss of battery and ground
 - Integrated output clamp to demagnetize inductive loads
 - Configurable fault handling
- Analog sense output can be configured to accurately measure:
 - Load current
 - Device temperature
- Provides fault indication through SNS pin or $\overline{\text{FLT}}$ pin
 - Detection of open load and short-to-battery

2 Applications

- [Automotive display module](#)
- [65-W Automotive headlight](#)
- [ADAS modules](#)
- [Seat comfort module](#)
- [Transmission control unit](#)
- [HVAC control module](#)
- [Body control modules](#)
- [Incandescent and LED lighting](#)

3 Description

The TPS1HB08-Q1 device is a smart high-side switch intended for use in 12-V automotive systems. The device integrates robust protection and diagnostic features to ensure output port protection even during harmful events like short circuits in automotive systems. The device protects against faults through a [reliable current limit](#), which, depending on device variant, is adjustable from 6.4 A to 70 A or set at 94 A. The high current limit range allows for usage in loads that require large transient currents, while the low current limit range provides improved protection for loads that do not require high peak current. The device is capable of reliably driving a wide range of [load profiles](#).

The TPS1HB08-Q1 also provides a high accuracy analog sense sense that allows for improved load diagnostics. By reporting load current and device temperature to a system MCU, the device enables predictive maintenance and load diagnostics that improves the system lifetime.

The TPS1HB08-Q1 is available in a HTSSOP package which allows for reduced PCB footprint.

Device Information⁽¹⁾

PART NUMBER	PACKAGE	BODY SIZE (NOM)
TPS1HB08-Q1	HTSSOP (16)	5.0 mm × 4.40 mm

(1) For all available packages, see the orderable addendum at the end of the data sheet.

Simplified Schematic

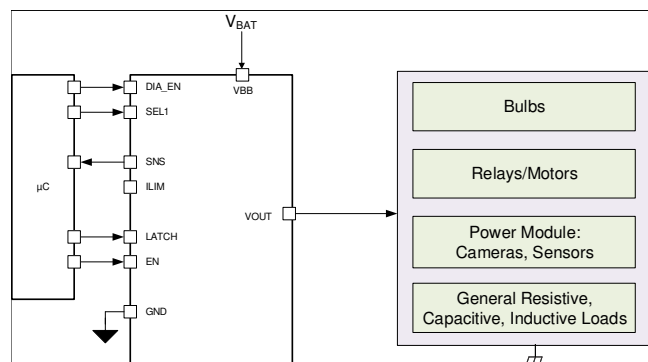

Table of Contents

1 Features 1 2 Applications 1 3 Description 1 4 Revision History 2 5 Device Comparison Table 3 6 Pin Configuration and Functions 3 6.1 Recommended Connections for Unused Pins 4 7 Specifications 5 7.1 Absolute Maximum Ratings 5 7.2 ESD Ratings..... 5 7.3 Recommended Operating Conditions 5 7.4 Thermal Information 5 7.5 Electrical Characteristics..... 6 7.6 SNS Timing Characteristics 8 7.7 Switching Characteristics 9 7.8 Typical Characteristics 10 8 Parameter Measurement Information 15 9 Detailed Description 17 9.1 Overview 17	9.2 Functional Block Diagram 18 9.3 Feature Description..... 18 9.4 Device Functional Modes..... 30 10 Application and Implementation 32 10.1 Application Information..... 32 10.2 Typical Application 35 10.3 Typical Application 38 11 Power Supply Recommendations 39 12 Layout 40 12.1 Layout Guidelines 40 12.2 Layout Example 40 13 Device and Documentation Support 41 13.1 Documentation Support 41 13.2 Receiving Notification of Documentation Updates 41 13.3 Support Resources 41 13.4 Trademarks 41 13.5 Electrostatic Discharge Caution..... 41 13.6 Glossary 41 14 Mechanical, Packaging, and Orderable Information 41
------------------------------------------------------------------------------------------------------------------------------------------------------------------------------------------------------------------------------------------------------------------------------------------------------------------------------------------------------------------------------------------------------------------------------------------------------------------------------------------------------------------------------------------------------------------------------------------------------------------------------------------------------------------------------------------------------------------------------------------------------------------------------	--------------------------------------------------------------------------------------------------------------------------------------------------------------------------------------------------------------------------------------------------------------------------------------------------------------------------------------------------------------------------------------------------------------------------------------------------------------------------------------------------------------------------------------------------------------------------------------------------------------------------------------------------------------------------------------------------------------------------------------------------------------------------------------------------------------------

4 Revision History

Changes from Revision B (December 2019) to Revision C	Page
<ul style="list-style-type: none"> • Deleted tablenote from the Device Comparison Table to remove product preview from Versions A and B..... 3 	3
Changes from Revision A (December 2019) to Revision B	Page
<ul style="list-style-type: none"> • Added functional safety capable link to the Features section 1 	1
Changes from Original (May 2019) to Revision A	Page
<ul style="list-style-type: none"> • Changed from Advance Information to Production Data 1 	1

5 Device Comparison Table

Table 1. Device Options

Device Version	Part Number	Current Limit	Current Limit Range	Overcurrent Behavior
A	TPS1HB08A-Q1	Resistor Programmable	6.4 A to 32 A	Disable switch immediately
B	TPS1HB08B-Q1	Resistor Programmable	14 A to 70 A	Disable switch immediately
F	TPS1HB08F-Q1	Internally Set	94 A	Disable switch immediately

6 Pin Configuration and Functions

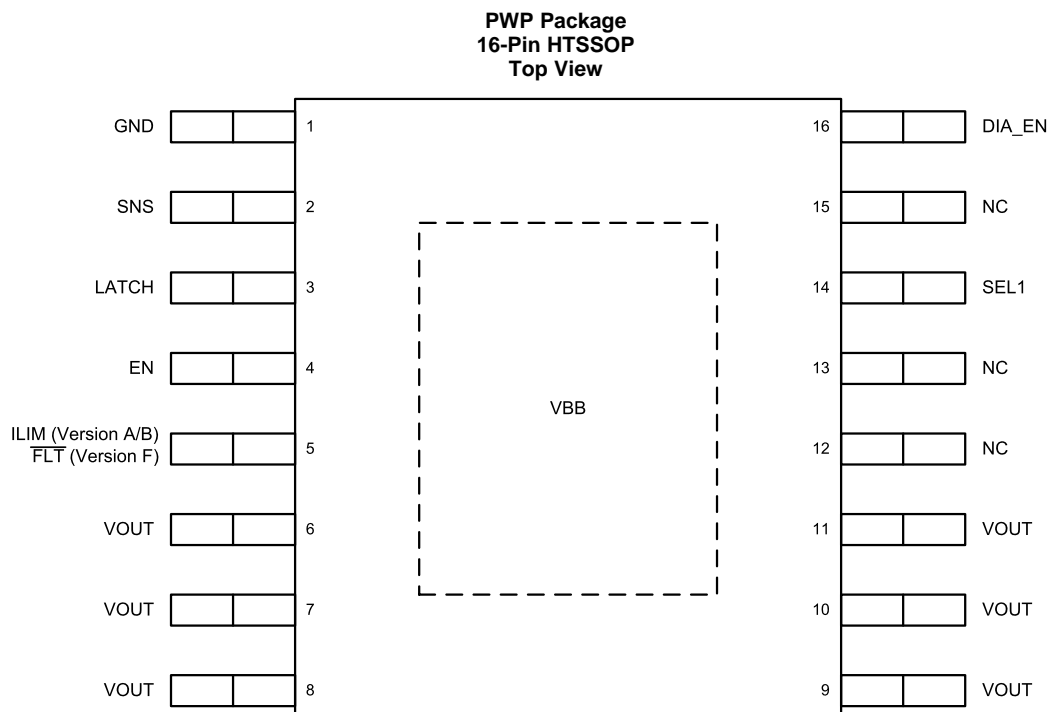
Pin Functions

NAME	PIN		I/O	DESCRIPTION
	Version A/B	Version F		
GND	1	1	—	Device ground
SNS	2	2	O	Sense output
LATCH	3	3	I	Sets fault handling behavior (latched or auto-retry)
EN	4	4	I	Control input, active high
ILIM	5	-	O	Connect resistor to set current-limit threshold
FLT	-	5	O	Open drain output with pulldown to signal fault.
VOUT	6 - 11	6 - 11	O	Channel output
NC	12 - 13, 15	12 - 13, 15	I	No Connect, leave floating
SEL1	14	14	I	Diagnostics select. No functionality on device version F; connect to IC GND through R _{PROT} resistor
DIA_EN	16	16	I	Diagnostic enable, active high
VBB	Exposed pad	Exposed pad	I	Power supply input

6.1 Recommended Connections for Unused Pins

The TPS1HB08-Q1 is designed to provide an enhanced set of diagnostic and protection features. However, if the system design only allows for a limited number of I/O connections, some pins may be considered as optional.

Table 2. Connections for Optional Pins

PIN NAME	CONNECTION IF NOT USED	IMPACT IF NOT USED
SNS	Ground through 1-kΩ resistor	Analog sense is not available.
LATCH	Float or ground through R _{PROT} resistor	With LATCH unused, the device will auto-retry after a fault. If latched behavior is desired, but the system describes limited I/O, it is possible to use one microcontroller output to control the latch function of several high-side channels.
ILIM (Version A/B)	Float	If the ILIM pin is left floating, the device will be set to the default internal current-limit threshold. This is considered a fault state for the device.
$\overline{\text{FLT}}$ (Version F)	Float	If the $\overline{\text{FLT}}$ pin is unused, the system cannot read faults from the output.
SEL1	Ground through R _{PROT} resistor	SEL1 selects the T _J sensing feature. With SEL1 unused, only current sensing and open load detection are available. If unused, must be grounded through a resistor to engage FET turn-on during reverse battery.
DIA_EN	Float or ground through R _{PROT} resistor	With DIA_EN unused, the analog sense, open-load, and short-to-battery diagnostics are not available.

7 Specifications

7.1 Absolute Maximum Ratings

Over operating free-air temperature range (unless otherwise noted)⁽¹⁾

		MIN	MAX	UNIT
Maximum continuous supply voltage, V_{BB}			36	V
Load dump voltage, V_{LD}	ISO16750-2:2010(E)		40	V
Reverse battery voltage, V_{Rev} , $t \leq 3$ minutes		-18		V
Enable pin voltage, V_{EN}		-1	7	V
LATCH pin voltage, V_{LATCH}		-1	7	V
Diagnostic Enable pin voltage, V_{DIA_EN}		-1	7	V
Sense pin voltage, V_{SNS}		-1	18	V
Select pin voltage, V_{SEL}		-1	7	V
Reverse ground current, I_{GND}		$V_{BB} < 0$ V	-50	mA
Energy dissipation during turnoff, E_{TOFF}		Single pulse, $L_{OUT} = 5$ mH, $T_{J,start} = 125^\circ\text{C}$	95 ⁽²⁾	mJ
Energy dissipation during turnoff, E_{TOFF}		Repetitive pulse, $L_{OUT} = 5$ mH, $T_{J,start} = 125^\circ\text{C}$	56 ⁽²⁾	mJ
Maximum junction temperature, T_J			150	$^\circ\text{C}$
Storage temperature, T_{stg}		-65	150	$^\circ\text{C}$

- (1) Stresses beyond those listed under *Absolute Maximum Ratings* may cause permanent damage to the device. These are stress ratings only, which do not imply functional operation of the device at these or any other conditions beyond those indicated under *Recommended Operating Conditions*. Exposure to absolute maximum rated conditions for extended periods may affect device reliability.
- (2) For further details, see the section regarding switch-off of an inductive load.

7.2 ESD Ratings

				VALUE	UNIT
$V_{(ESD)}$	Electrostatic discharge	Human-body model (HBM), per AEC Q100-002 ⁽¹⁾	All pins except V_{BB} and V_{OUT}	± 2000	V
			V_{BB} and V_{OUT}	± 4000	
		Charged-device model (CDM), per AEC Q100-011	All pins	± 750	

- (1) AEC-Q100-002 indicates that HBM stressing shall be in accordance with the ANSI/ESDA/JEDEC JS-001 specifications.

7.3 Recommended Operating Conditions

over operating free-air temperature range (unless otherwise noted)⁽¹⁾

		MIN	MAX	UNIT
V_{BB}	Nominal supply voltage ⁽¹⁾	6	18	V
V_{BB}	Extended supply voltage ⁽²⁾	3	28	V
V_{EN}	Enable voltage	-1	5.5	V
V_{LATCH}	LATCH voltage	-1	5.5	V
V_{DIA_EN}	Diagnostic Enable voltage	-1	5.5	V
V_{SEL1}	Select voltage	-1	5.5	V
V_{SNS}	Sense voltage	-1	7	V

- (1) All operating voltage conditions are measured with respect to device GND
- (2) Device will function within extended operating range, however some parametric values might not apply

7.4 Thermal Information

THERMAL METRIC ^{(1) (2)}		TPS1HB08-Q1	UNIT
		PWP (HTSSOP)	
		16 PINS	
$R_{\theta JA}$	Junction-to-ambient thermal resistance	32.6	$^\circ\text{C}/\text{W}$

- (1) For more information about traditional and new thermal metrics, see the [Semiconductor and IC Package Thermal Metrics](#) application report.
- (2) The thermal parameters are based on a 4-layer PCB according to the JESD51-5 and JESD51-7 standards.

Thermal Information (continued)

THERMAL METRIC ⁽¹⁾ ⁽²⁾		TPS1HB08-Q1	UNIT
		PWP (HTSSOP)	
		16 PINS	
$R_{\theta JC(top)}$	Junction-to-case (top) thermal resistance	25.3	°C/W
$R_{\theta JB}$	Junction-to-board thermal resistance	9.2	°C/W
Ψ_{JT}	Junction-to-top characterization parameter	2.3	°C/W
Ψ_{JB}	Junction-to-board characterization parameter	9.3	°C/W
$R_{\theta JC(bot)}$	Junction-to-case (bottom) thermal resistance	1.0	°C/W

7.5 Electrical Characteristics
 $V_{BB} = 6\text{ V to }18\text{ V}$, $T_J = -40^\circ\text{C to }150^\circ\text{C}$ (unless otherwise noted)

PARAMETER		TEST CONDITIONS	MIN	TYP	MAX	UNIT
INPUT VOLTAGE AND CURRENT						
$V_{DSClamp}$	V_{DS} clamp voltage		40		46	V
$V_{BBClamp}$	V_{BB} clamp voltage		58		76	V
V_{UVLOF}	V_{BB} undervoltage lockout falling	Measured with respect to the GND pin of the device	2.0		3	V
V_{UVLOR}	V_{BB} undervoltage lockout rising	Measured with respect to the GND pin of the device	2.2		3	V
I_{SB}	Standby current (total device leakage including MOSFET)	$V_{BB} = 13.5\text{ V}$, $T_J = 25^\circ\text{C}$ $V_{EN} = V_{DIA_EN} = 0\text{ V}$, $V_{OUT} = 0\text{ V}$			0.1	μA
		$V_{BB} = 13.5\text{ V}$, $T_J = 85^\circ\text{C}$, $V_{EN} = V_{DIA_EN} = 0\text{ V}$, $V_{OUT} = 0\text{ V}$			0.5	μA
I_{L_NOM}	Continuous load current	$T_{AMB} = 70^\circ\text{C}$		11		A
$I_{OUT(standby)}$	Output leakage current	$V_{BB} = 13.5\text{ V}$, $T_J = 25^\circ\text{C}$ $V_{EN} = V_{DIA_EN} = 0\text{ V}$, $V_{OUT} = 0\text{ V}$		0.01	0.5	μA
		$V_{BB} = 13.5\text{ V}$, $T_J = 125^\circ\text{C}$ $V_{EN} = V_{DIA_EN} = 0\text{ V}$, $V_{OUT} = 0\text{ V}$			3	μA
I_{DIA}	Current consumption in diagnostic mode	$V_{BB} = 13.5\text{ V}$, $I_{SNS} = 0\text{ mA}$ $V_{EN} = 0\text{ V}$, $V_{DIA_EN} = 5\text{ V}$, $V_{OUT} = 0\text{ V}$		3	6	mA
I_Q	Quiescent current	$V_{BB} = 13.5\text{ V}$ $V_{EN} = V_{DIA_EN} = 5\text{ V}$, $I_{OUT} = 0\text{ A}$		3	6	mA
t_{STBY}	Standby mode delay time	$V_{EN} = V_{DIA_EN} = 0\text{ V}$ to standby	12	17	22	ms
RON CHARACTERISTICS						
R_{ON}	On-resistance (Includes MOSFET and package)	$T_J = 25^\circ\text{C}$, $6\text{ V} \leq V_{BB} \leq 28\text{ V}$		8		m Ω
		$T_J = 150^\circ\text{C}$, $6\text{ V} \leq V_{BB} \leq 28\text{ V}$			16	m Ω
		$T_J = 25^\circ\text{C}$, $3\text{ V} \leq V_{BB} \leq 6\text{ V}$			12	m Ω
$R_{ON(REV)}$	On-resistance during reverse polarity	$T_J = 25^\circ\text{C}$, $-18\text{ V} \leq V_{BB} \leq -8\text{ V}$		8		m Ω
		$T_J = 105^\circ\text{C}$, $-18\text{ V} \leq V_{BB} \leq -8\text{ V}$			16	m Ω
CURRENT SENSE CHARACTERISTICS						
K_{SNS}	Current sense ratio I_{OUT} / I_{SNS}	$I_{OUT} = 1\text{ A}$		5000		

Electrical Characteristics (continued)
 $V_{BB} = 6\text{ V to }18\text{ V}$, $T_J = -40^\circ\text{C to }150^\circ\text{C}$ (unless otherwise noted)

PARAMETER		TEST CONDITIONS		MIN	TYP	MAX	UNIT
I_{SNSI}	Current sense current and accuracy	$V_{EN} = V_{DIA_EN} = 5\text{ V}$, $V_{SEL1} = 0\text{ V}$	$I_{OUT} = 10\text{ A}$		2.000		mA
					-5		5.3
			$I_{OUT} = 3\text{ A}$		0.6		mA
					-5		5.3
			$I_{OUT} = 1\text{ A}$		0.2		mA
					-5		5.3
			$I_{OUT} = 300\text{ mA}$		0.06043		mA
					-4.6		6.2
$I_{OUT} = 100\text{ mA}$		0.0206		mA			
		-13.6		15.1	%		
$I_{OUT} = 50\text{ mA}$		0.0106		mA			
		-28.3		30.3	%		
$I_{OUT} = 20\text{ mA}$		0.0046		mA			
		-56		57.3	%		
TJ SENSE CHARACTERISTICS							
I_{SNSST}	Temperature sense current Device Version A/B	$V_{DIA_EN} = 5\text{ V}$, $V_{SEL1} = 5\text{ V}$	$T_J = -40^\circ\text{C}$	0.01	0.12	0.38	mA
			$T_J = 25^\circ\text{C}$	0.72	0.85	0.98	mA
			$T_J = 85^\circ\text{C}$	1.25	1.52	1.79	mA
			$T_J = 125^\circ\text{C}$	1.61	1.96	2.31	mA
			$T_J = 150^\circ\text{C}$	1.80	2.25	2.70	mA
dI_{SNSST}/dT	Coefficient			0.0112		mA/°C	
SNS CHARACTERISTICS							
I_{SNSFH}	I_{SNS} fault high-level	$V_{DIA_EN} = 5\text{ V}$, $V_{SEL1} = 0\text{ V}$		4	4.5	5.3	mA
$I_{SNSleak}$	I_{SNS} leakage	$V_{DIA_EN} = 0\text{ V}$				1	µA
CURRENT LIMIT CHARACTERISTICS							
I_{CL}	Current limit threshold	Device Version A, $T_J = -40^\circ\text{C to }150^\circ\text{C}$	$R_{ILIM} = \text{GND, open, or out of range}$		42		A
			$R_{ILIM} = 5\text{ k}\Omega$	27.2	32	36.8	A
			$R_{ILIM} = 25\text{ k}\Omega$	4.7	6.4	8.1	A
		Device Version B, $T_J = -40^\circ\text{C to }150^\circ\text{C}$	$R_{ILIM} = \text{GND, open, or out of range}$		104		A
			$R_{ILIM} = 5\text{ k}\Omega$	47.1	70	84.2	A
			$R_{ILIM} = 25\text{ k}\Omega$	9.9	14	17.8	A
		Device Version F	$T_J = -40^\circ\text{C to }60^\circ\text{C}$	80	94	105	A
			$T_J = 150^\circ\text{C}$	68	77	86.1	A
K_{CL}	Current Limit Ratio	Version A		120	160	208	A * kΩ
		Version B		245	350	437.5	A * kΩ
FAULT CHARACTERISTICS							
V_{OL}	Open-load (OL) detection voltage	$V_{EN} = 0\text{ V}$, $V_{DIA_EN} = 5\text{ V}$, $V_{SEL1} = 0\text{ V}$		2	3	4	V
V_{FLT}	FLT low output voltage (Version F only)	$I_{FLT} = 1\text{ mA}$				1	V
t_{OL1}	OL and STB indication-time from EN falling	$V_{EN} = 5\text{ V to }0\text{ V}$, $V_{DIA_EN} = 5\text{ V}$, $V_{SEL1} = 0\text{ V}$ $I_{OUT} = 0\text{ mA}$, $V_{OUT} = 4\text{ V}$		300	500	700	µs
t_{OL2}	OL and STB indication-time from DIA_EN rising	$V_{EN} = 0\text{ V}$, $V_{DIA_EN} = 0\text{ V to }5\text{ V}$, $V_{SEL1} = 0\text{ V}$ $I_{OUT} = 0\text{ mA}$, $V_{OUT} = 4\text{ V}$		2	20	50	µs
t_{OL3}	OL and STB indication-time from VOUT rising	$V_{EN} = 0\text{ V}$, $V_{DIA_EN} = 5\text{ V}$, $V_{SEL1} = 0\text{ V}$ $I_{OUT} = 0\text{ mA}$, $V_{OUT} = 0\text{ V to }4\text{ V}$		2	20	50	µs

Electrical Characteristics (continued)

 $V_{BB} = 6\text{ V to }18\text{ V}$, $T_J = -40^\circ\text{C to }150^\circ\text{C}$ (unless otherwise noted)

PARAMETER		TEST CONDITIONS	MIN	TYP	MAX	UNIT
T_{ABS}	Thermal shutdown		150			$^\circ\text{C}$
T_{HYS}	Thermal shutdown hysteresis		20	25	30	$^\circ\text{C}$
t_{FAULT}	Fault shutdown indication-time	$V_{DIA_EN} = 5\text{ V}$ Time between switch shutdown and I_{SNS} settling at I_{SNSFH}			50	μs
t_{RETRY}	Retry time	Time from fault shutdown until switch re-enable (thermal shutdown or current limit).	1	2	3	ms
EN PIN CHARACTERISTICS						
V_{IL_EN}	Input voltage low-level	No GND network diode			0.8	V
V_{IH_EN}	Input voltage high-level	No GND network diode	2.0			V
V_{IHYS_EN}	Input voltage hysteresis			350		mV
R_{EN}	Internal pulldown resistor		0.5	1	2	$\text{M}\Omega$
I_{IL_EN}	Input current low-level	$V_{EN} = 0.8\text{ V}$		0.8		μA
I_{IH_EN}	Input current high-level	$V_{EN} = 5\text{ V}$		5.0		μA
DIA_EN PIN CHARACTERISTICS						
$V_{IL_DIA_EN}$	Input voltage low-level	No GND network diode			0.8	V
$V_{IH_DIA_EN}$	Input voltage high-level	No GND network diode	2.0			V
$V_{IHYS_DIA_EN}$	Input voltage hysteresis			350		mV
R_{DIA_EN}	Internal pulldown resistor		0.5	1	2	$\text{M}\Omega$
$I_{IL_DIA_EN}$	Input current low-level	$V_{DIA_EN} = 0.8\text{ V}$		0.8		μA
$I_{IH_DIA_EN}$	Input current high-level	$V_{DIA_EN} = 5\text{ V}$		5.0		μA
SEL1 PIN CHARACTERISTICS						
V_{IL_SEL1}	Input voltage low-level	No GND network diode			0.8	V
V_{IH_SEL1}	Input voltage high-level	No GND network diode	2.0			V
V_{IHYS_SEL1}	Input voltage hysteresis			350		mV
R_{SEL1}	Internal pulldown resistor		0.5	1	2	$\text{M}\Omega$
I_{IL_SEL1}	Input current low-level	$V_{SEL1} = 0.8\text{ V}$		0.8		μA
I_{IH_SEL1}	Input current high-level	$V_{SEL1} = 5\text{ V}$		5		μA
LATCH PIN CHARACTERISTICS						
V_{IL_LATCH}	Input voltage low-level	No GND network diode			0.8	V
V_{IH_LATCH}	Input voltage high-level	No GND network diode	2.0			V
V_{IHYS_LATCH}	Input voltage hysteresis			350		mV
R_{LATCH}	Internal pulldown resistor		0.5	1	2	$\text{M}\Omega$
I_{IL_LATCH}	Input current low-level	$V_{LATCH} = 0.8\text{ V}$		0.8		μA
I_{IH_LATCH}	Input current high-level	$V_{LATCH} = 5\text{ V}$		5.0		μA

7.6 SNS Timing Characteristics

 $V_{BB} = 6\text{ V to }18\text{ V}$, $T_J = -40^\circ\text{C to }+150^\circ\text{C}$ (unless otherwise noted)

PARAMETER		TEST CONDITIONS	MIN	TYP	MAX	UNIT
SNS TIMING - CURRENT SENSE						
$t_{SNSION1}$	Settling time from rising edge of DIA_EN	$V_{EN} = 5\text{ V}$, $V_{DIA_EN} = 0\text{ V to }5\text{ V}$ $R_{SNS} = 1\text{ k}\Omega$, $R_L = 2.6\ \Omega$			40	μs
$t_{SNSION2}$	Settling time from rising edge of EN and DIA_EN	$V_{EN} = V_{DIA_EN} = 0\text{ V to }5\text{ V}$ $R_{SNS} = 1\text{ k}\Omega$, $R_L = 2.6\ \Omega$			200	μs

SNS Timing Characteristics (continued)

 $V_{BB} = 6\text{ V to }18\text{ V}$, $T_J = -40^\circ\text{C to }+150^\circ\text{C}$ (unless otherwise noted)

PARAMETER		TEST CONDITIONS	MIN	TYP	MAX	UNIT
t_{SNSION3}	Settling time from rising edge of EN	$V_{\text{EN}} = 0\text{ V to }5\text{ V}$, $V_{\text{DIA_EN}} = 5\text{ V}$ $R_{\text{SNS}} = 1\text{ k}\Omega$, $R_L = 2.6\ \Omega$			165	μs
t_{SNSIOFF1}	Settling time from falling edge of DIA_EN	$V_{\text{EN}} = 5\text{ V}$, $V_{\text{DIA_EN}} = 5\text{ V to }0\text{ V}$ $R_{\text{SNS}} = 1\text{ k}\Omega$, $R_L = 2.6\ \Omega$			20	μs
t_{SETTLEH}	Settling time from rising edge of load step	$V_{\text{EN}} = 5\text{ V}$, $V_{\text{DIA_EN}} = 5\text{ V}$ $R_{\text{SNS}} = 1\text{ k}\Omega$, $I_{\text{OUT}} = 1\text{ A to }5\text{ A}$			20	μs
t_{SETTLEL}	Settling time from falling edge of load step	$V_{\text{EN}} = 5\text{ V}$, $V_{\text{DIA_EN}} = 5\text{ V}$ $R_{\text{SNS}} = 1\text{ k}\Omega$, $I_{\text{OUT}} = 5\text{ A to }1\text{ A}$			20	μs
SNS TIMING - TEMPERATURE SENSE						
t_{SNSTON1}	Settling time from rising edge of DIA_EN	$V_{\text{EN}} = 5\text{ V}$, $V_{\text{DIA_EN}} = 0\text{ V to }5\text{ V}$ $R_{\text{SNS}} = 1\text{ k}\Omega$			40	μs
t_{SNSTON2}	Settling time from rising edge of DIA_EN	$V_{\text{EN}} = 0\text{ V}$, $V_{\text{DIA_EN}} = 0\text{ V to }5\text{ V}$ $R_{\text{SNS}} = 1\text{ k}\Omega$			70	μs
t_{SNSTOFF}	Settling time from falling edge of DIA_EN	$V_{\text{EN}} = X$, $V_{\text{DIA_EN}} = 5\text{ V to }0\text{ V}$ $R_{\text{SNS}} = 1\text{ k}\Omega$			20	μs
SNS TIMING - MULTIPLEXER						
t_{MUX}	Settling time from temperature sense to current sense	$V_{\text{EN}} = 5\text{ V}$, $V_{\text{DIA_EN}} = 5\text{ V}$ $V_{\text{SEL1}} = 5\text{ V to }0\text{ V}$ $R_{\text{SNS}} = 1\text{ k}\Omega$, $R_L = 2.6\ \Omega$			60	μs
	Settling time from current sense to temperature sense	$V_{\text{EN}} = 5\text{ V}$, $V_{\text{DIA_EN}} = 5\text{ V}$ $V_{\text{SEL1}} = 0\text{ V to }5\text{ V}$ $R_{\text{SNS}} = 1\text{ k}\Omega$, $R_L = 2.6\ \Omega$			60	μs

7.7 Switching Characteristics

 $V_{BB} = 13.5\text{ V}$, $T_J = -40^\circ\text{C to }+150^\circ\text{C}$ (unless otherwise noted)

PARAMETER		TEST CONDITIONS	MIN	TYP	MAX	UNIT
t_{DR}	Turnon delay time (from Active)	$V_{\text{BB}} = 13.5\text{ V}$, $R_L = 2.6\ \Omega$, 50% EN rising to 10% V_{OUT} rising	20	60	100	μs
t_{DF}	Turnoff delay time	$V_{\text{BB}} = 13.5\text{ V}$, $R_L = 2.6\ \Omega$, 50% EN falling to 90% V_{OUT} Falling	20	60	100	μs
SR_R	V_{OUT} rising slew rate	$V_{\text{BB}} = 13.5\text{ V}$, 20% to 80% of V_{OUT} , $R_L = 2.6\ \Omega$	0.1	0.4	0.7	$\text{V}/\mu\text{s}$
SR_F	V_{OUT} falling slew rate	$V_{\text{BB}} = 13.5\text{ V}$, 80% to 20% of V_{OUT} , $R_L = 2.6\ \Omega$	0.1	0.4	0.7	$\text{V}/\mu\text{s}$
t_{ON}	Turnon time (active)	$V_{\text{BB}} = 13.5\text{ V}$, $R_L = 2.6\ \Omega$, 50% EN rising to 80% V_{OUT} rising	39	94	235	μs
t_{OFF}	Turnoff time	$V_{\text{BB}} = 13.5\text{ V}$, $R_L = 2.6\ \Omega$, 50% EN falling to 20% V_{OUT} falling	39	94	235	μs
Δ_{PWM}	PWM accuracy - average load current	200- μs enable pulse, $V_S = 13.5\text{ V}$, $R_L = 2.6\ \Omega$	-25	0	25	%
$t_{\text{ON}} - t_{\text{OFF}}$	Turnon and turnoff matching	200- μs enable pulse	-85	0	85	μs
E_{ON}	Switching energy losses during turnon	$V_{\text{BB}} = 13.5\text{ V}$, $R_L = 2.6\ \Omega$		0.8		mJ
E_{OFF}	Switching energy losses during turnoff	$V_{\text{BB}} = 13.5\text{ V}$, $R_L = 2.6\ \Omega$		0.8		mJ

7.8 Typical Characteristics

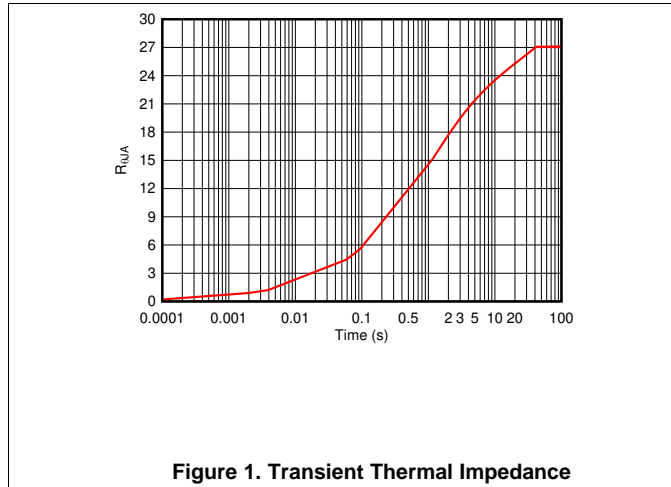

Figure 1. Transient Thermal Impedance

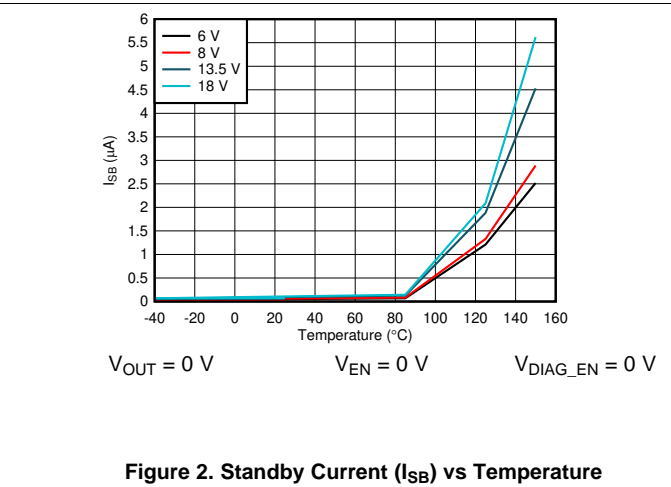

Figure 2. Standby Current (I_{SB}) vs Temperature

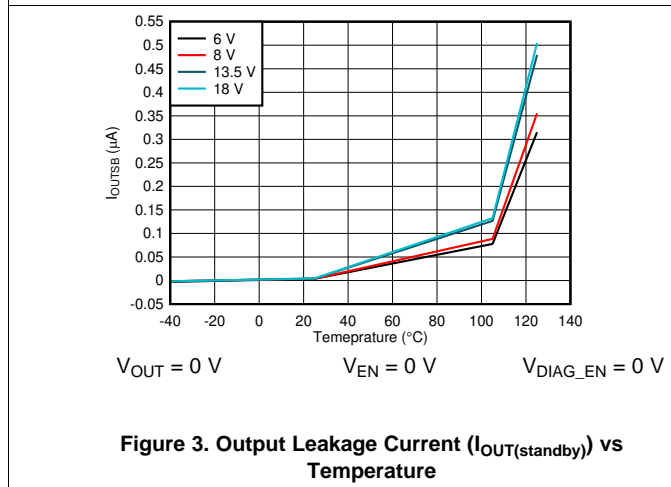

Figure 3. Output Leakage Current ($I_{OUT(standby)}$) vs Temperature

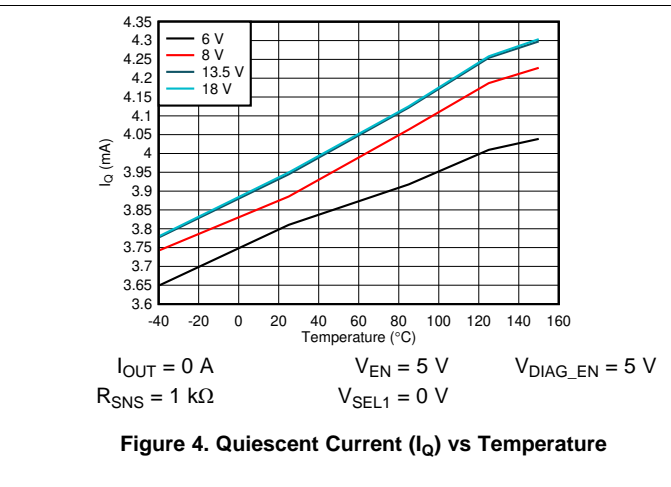

Figure 4. Quiescent Current (I_Q) vs Temperature

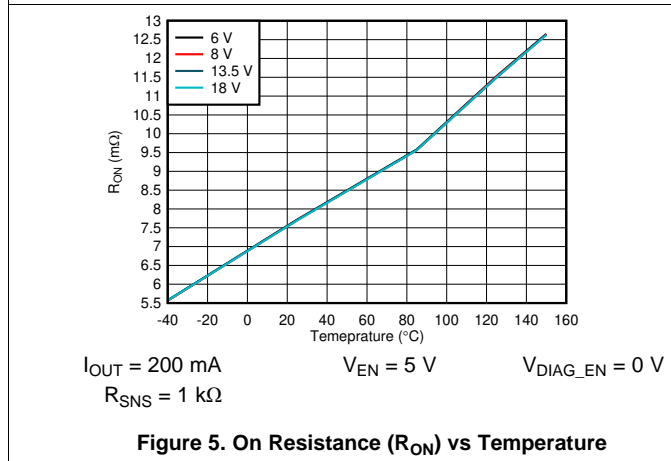

Figure 5. On Resistance (R_{ON}) vs Temperature

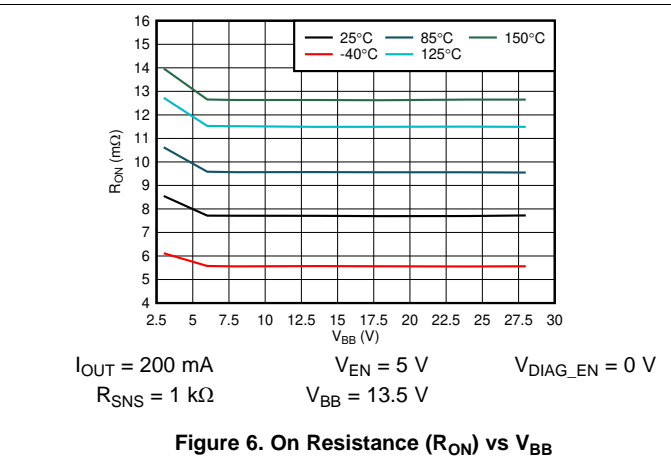
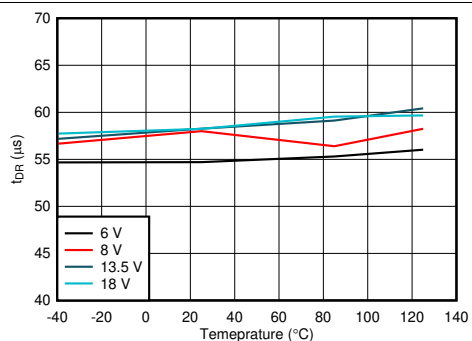

Figure 6. On Resistance (R_{ON}) vs V_{BB}

Typical Characteristics (continued)



$R_{OUT} = 2.6 \Omega$ $V_{EN} = 0 V \text{ to } 5 V$ $V_{DIAG_EN} = 0 V$
 $R_{SNS} = 1 k\Omega$ $V_{BB} = 13.5 V$

Figure 7. Turn-on Delay Time (t_{DR}) vs Temperature

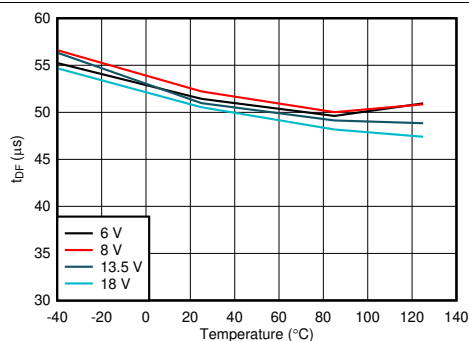

$R_{OUT} = 2.6 \Omega$ $V_{EN} = 5 V \text{ to } 0 V$ $V_{DIAG_EN} = 0 V$
 $R_{SNS} = 1 k\Omega$ $V_{BB} = 13.5 V$

Figure 8. Turn-off Delay Time (t_{DF}) vs Temperature

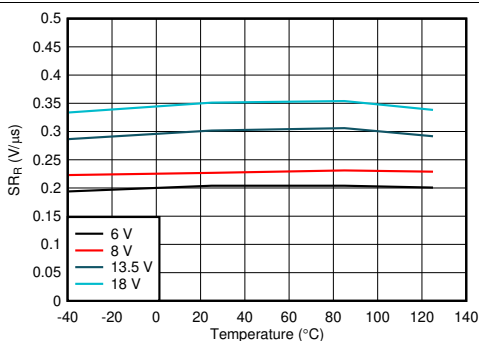

$R_{OUT} = 2.6 \Omega$ $V_{EN} = 0 V \text{ to } 5 V$ $V_{DIAG_EN} = 0 V$
 $R_{SNS} = 1 k\Omega$ $V_{BB} = 13.5 V$

Figure 9. V_{OUT} Slew Rate Rising (SR_R) vs Temperature

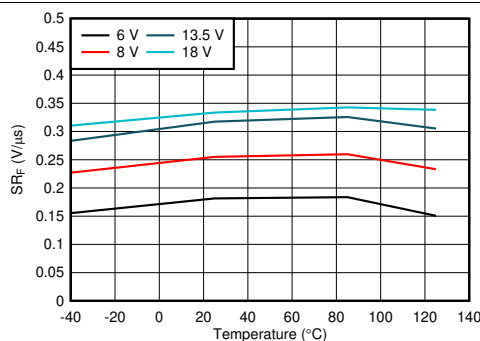

$R_{OUT} = 2.6 \Omega$ $V_{EN} = 5 V \text{ to } 0 V$ $V_{DIAG_EN} = 0 V$
 $R_{SNS} = 1 k\Omega$ $V_{BB} = 13.5 V$

Figure 10. V_{OUT} Slew Rate Falling (SR_F) vs Temperature

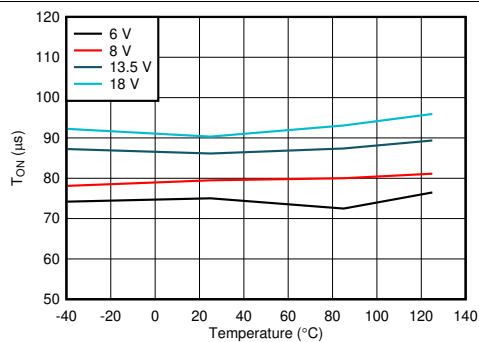

$R_{OUT} = 2.6 \Omega$ $V_{EN} = 0 V \text{ to } 5 V$ $V_{DIAG_EN} = 0 V$
 $R_{SNS} = 1 k\Omega$ $V_{BB} = 13.5 V$

Figure 11. Turn-on Time (t_{ON}) vs Temperature

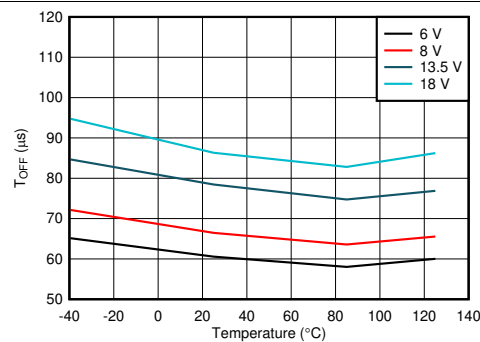

$R_{OUT} = 2.6 \Omega$ $V_{EN} = 5 V \text{ to } 0 V$ $V_{DIAG_EN} = 0 V$
 $R_{SNS} = 1 k\Omega$ $V_{BB} = 13.5 V$

Figure 12. Turn-off Time (t_{OFF}) vs Temperature

Typical Characteristics (continued)

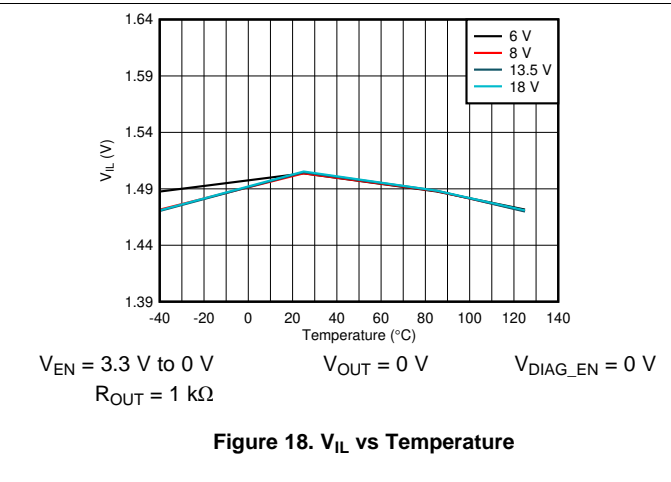
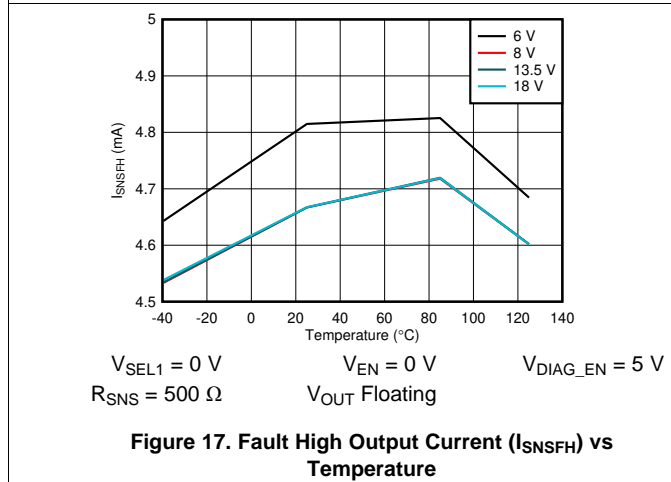
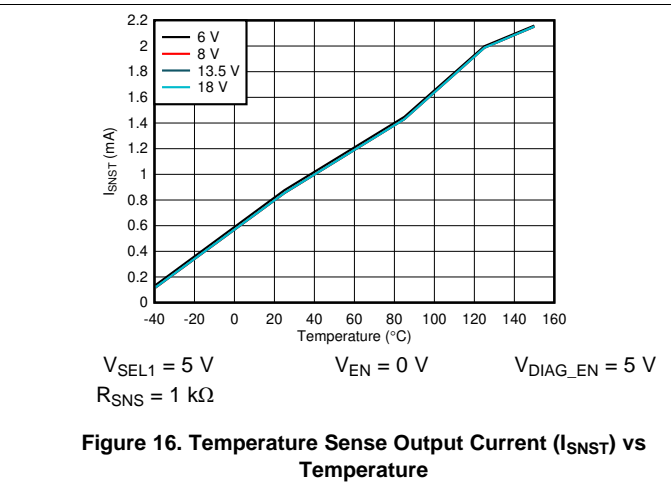
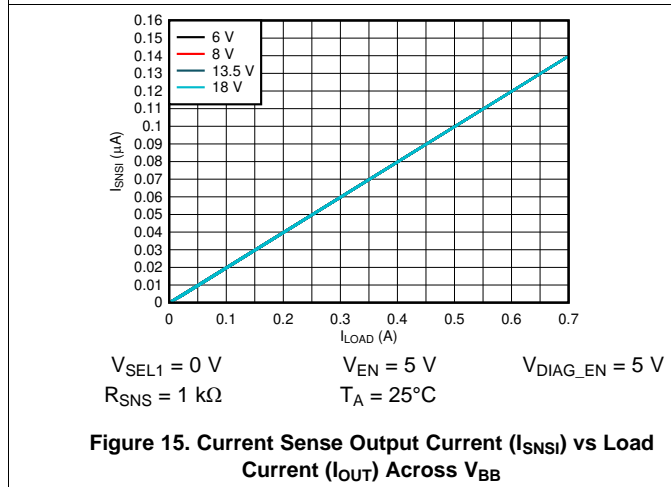
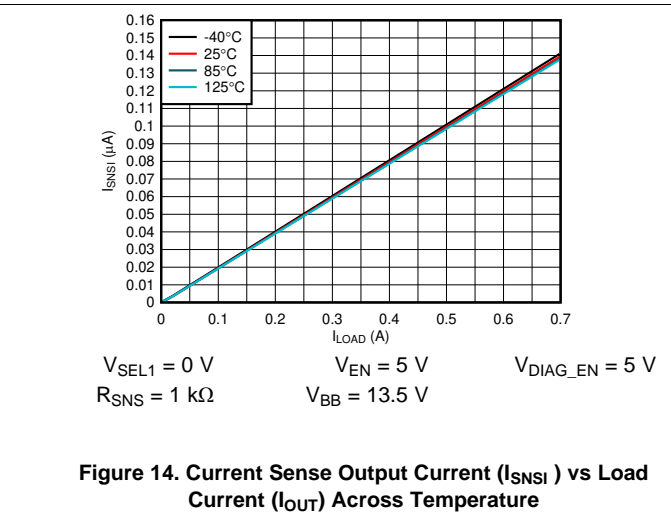
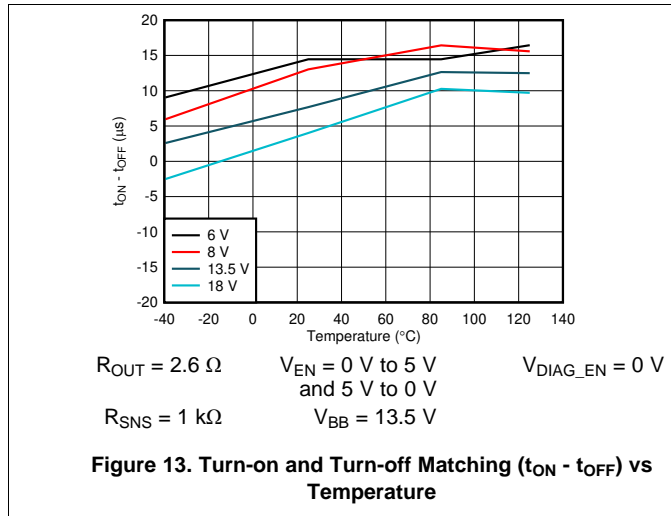

Typical Characteristics (continued)

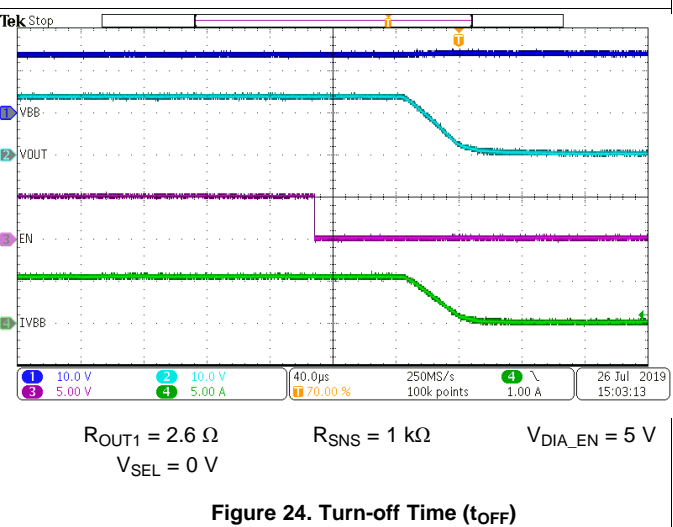
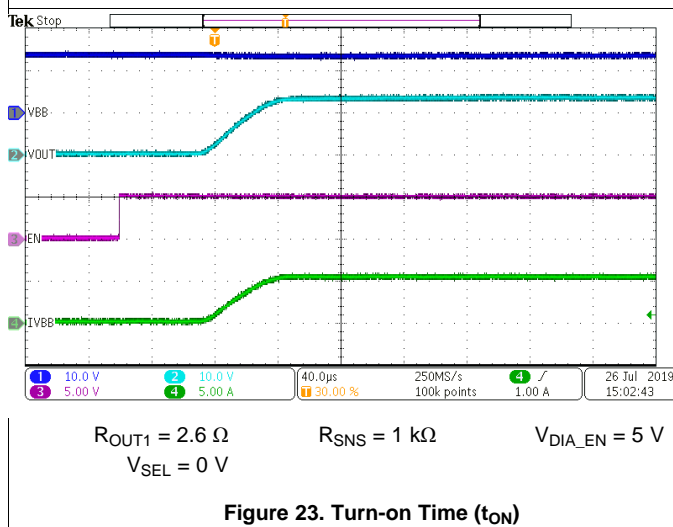
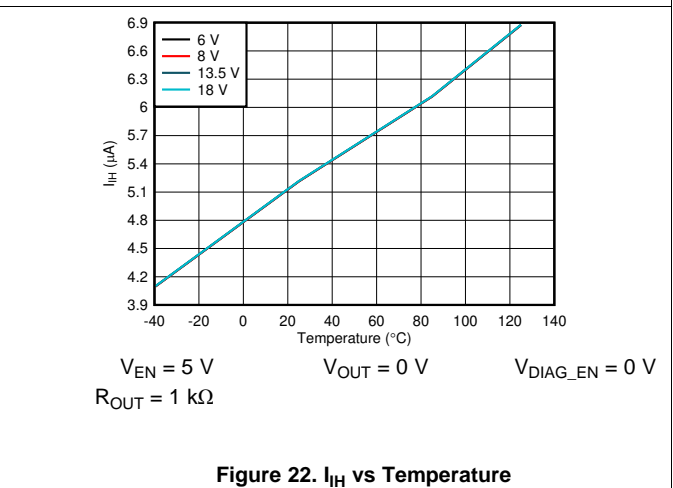
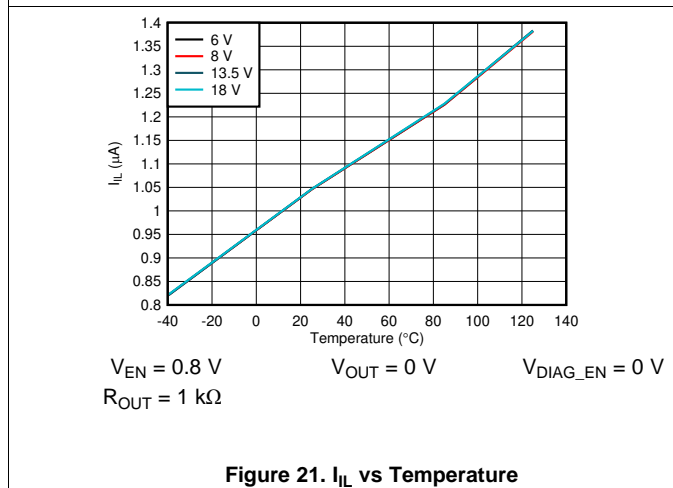
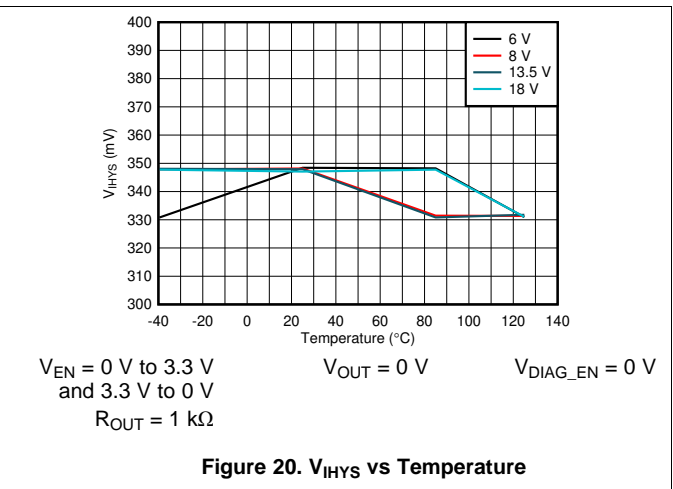
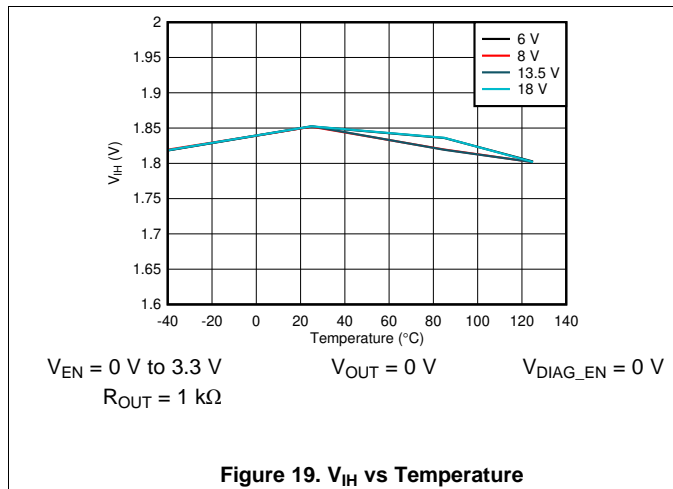

Typical Characteristics (continued)

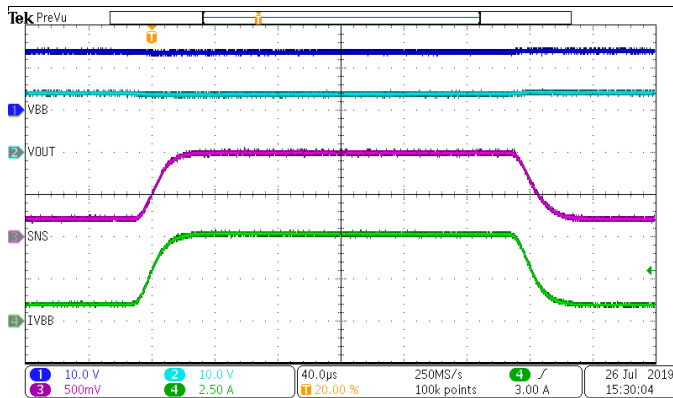

$R_{OUT1} = 2.6 \Omega$ $R_{SNS} = 1 \text{ k}\Omega$ $V_{SEL} = 0 \text{ V}$
 $I_{OUT1} = 1 \text{ A to } 5 \text{ A}$ $V_{BB} = 13.5 \text{ V}$

Figure 25. I_{SNS} Settling time ($t_{SNSION1}$) on Load Step

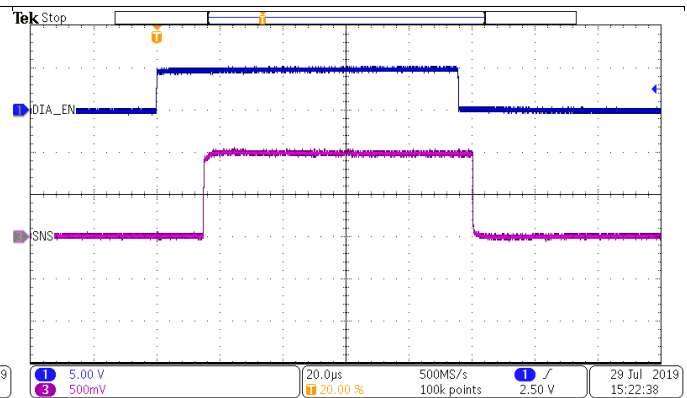

$V_{BB} = 13.5 \text{ V}$ $T_A = 25^\circ\text{C}$ $I_{OUT1} = 5 \text{ A}$
 $V_{EN} = 0 \text{ V to } 5 \text{ V}$

Figure 26. SNS Output Current Measurement Enable on DIAG_EN PWM

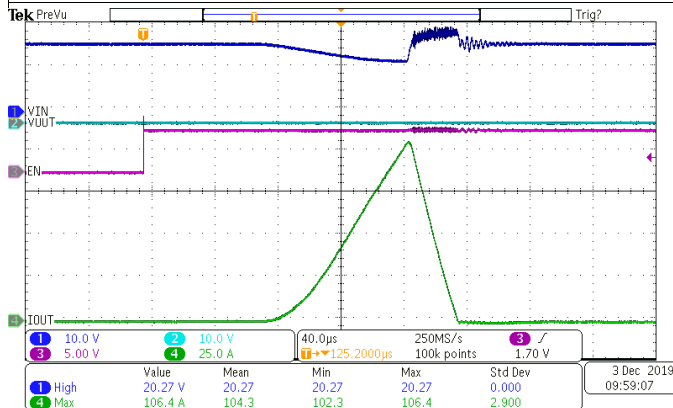

$L_{OUT} = 5 \mu\text{H to GND}$ $R_{SNS} = 1 \text{ k}\Omega$ $V_{SEL} = 0 \text{ V}$
 $V_{EN} = 0 \text{ V to } 5 \text{ V}$ $V_{DIAG_EN} = 5 \text{ V}$ $T_A = 25^\circ\text{C}$

Figure 27. Device Version F Short Circuit Event

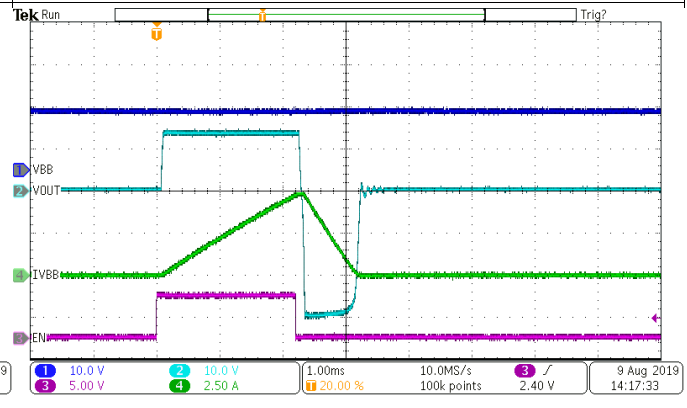

$V_{BB} = 13.5 \text{ V}$ $T_A = 25^\circ\text{C}$ $L_{OUT} = 5 \text{ mH}$

Figure 28. 5 mH Inductive Load Demagnetization

8 Parameter Measurement Information

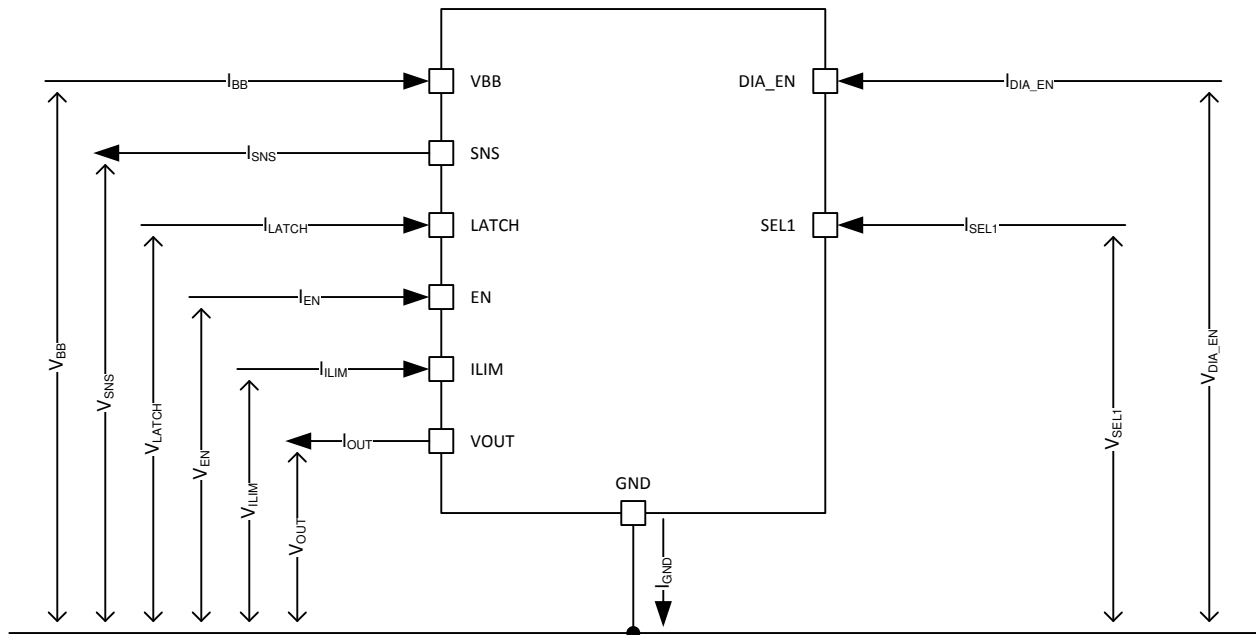

Figure 29. Parameter Definitions

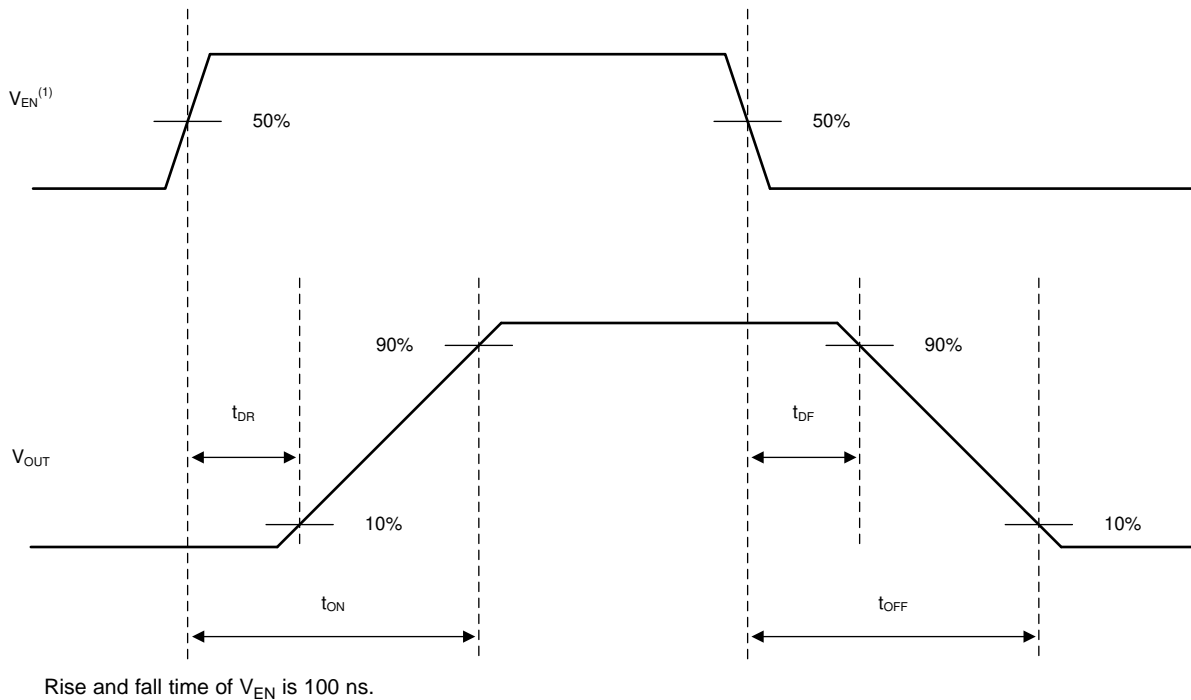
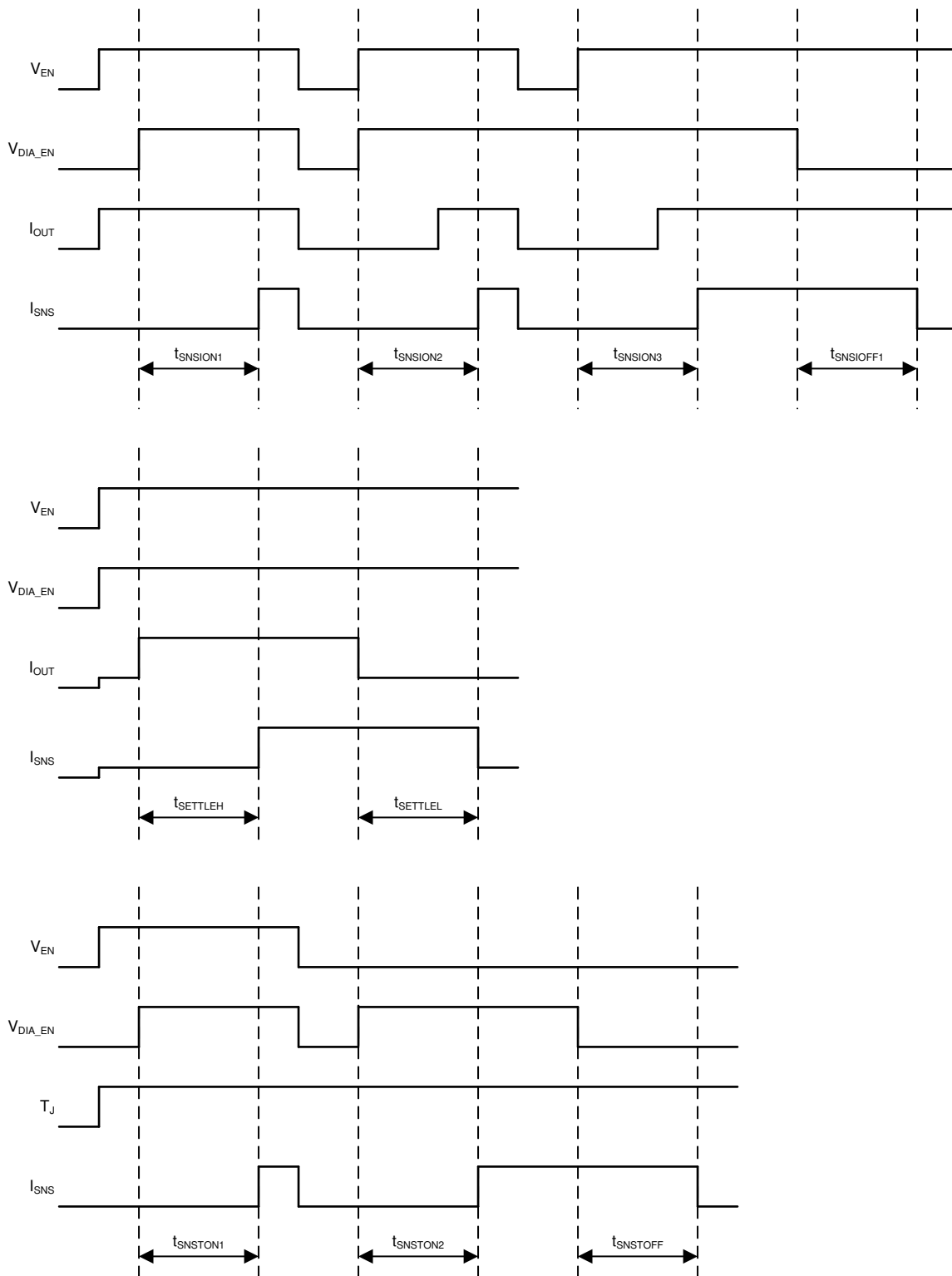

Figure 30. Switching Characteristics Definitions

Parameter Measurement Information (continued)

NOTES: Rise and fall times of control signals are 100 ns. Control signals include: EN, DIA_EN, SEL1
SEL1 pin must be set to the appropriate value.

Figure 31. SNS Timing Characteristics Definitions

9 Detailed Description

9.1 Overview

The TPS1HB08-Q1 device is a single-channel smart high-side switch intended for use with 12-V automotive batteries. Many protection and diagnostic features are integrated in the device.

Diagnostics features include the analog SNS output that is capable of providing a signal that is proportional to load current or device temperature. The high-accuracy load current sense allows for diagnostics of complex loads. Version F of the device includes an open drain FLT pin that indicates device fault states.

This device includes protection through thermal shutdown, current limiting, transient withstand, and reverse battery operation. For more details on the protection features, refer to the [Feature Description](#) and [Application Information](#) sections of the document.

The TPS1HB08-Q1 is one device in a family of TI high side switches. For each device, the part number indicates elements of the device behavior. [Figure 32](#) gives an example of the device nomenclature.

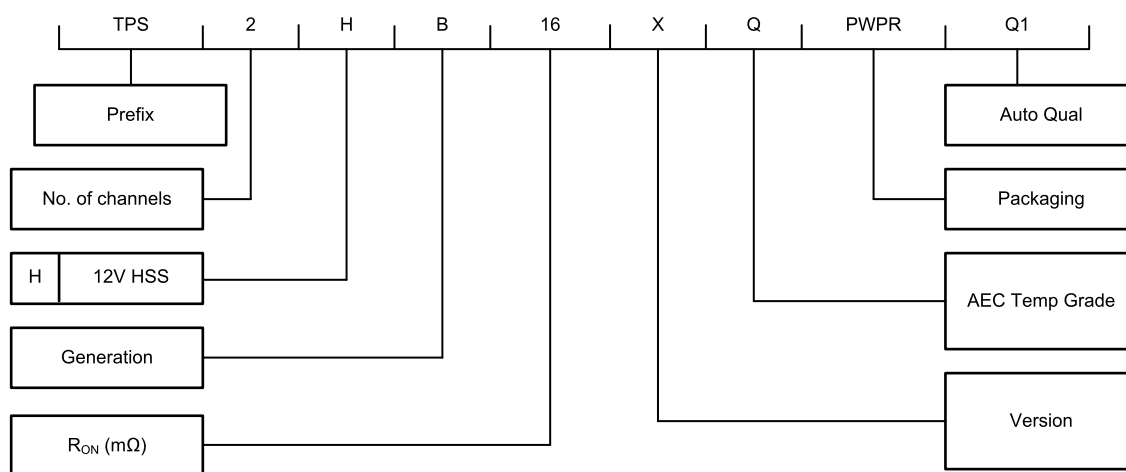
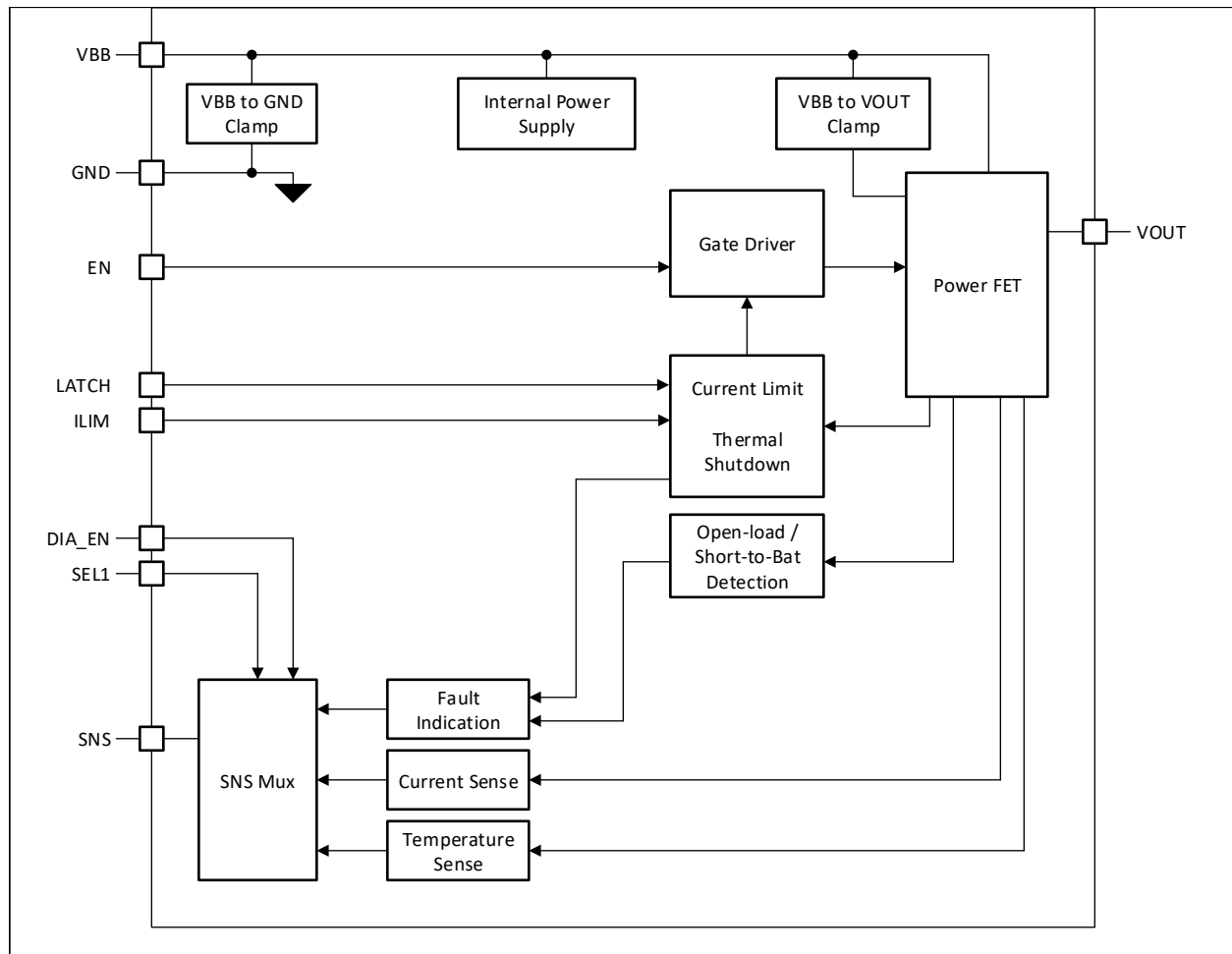

Figure 32. Naming Convention

9.2 Functional Block Diagram

The functional block diagram shown is for device versions A/B. For version F, the ILIM pin will be replaced by open drain output FLT.



9.3 Feature Description

9.3.1 Protection Mechanisms

The TPS1HB08-Q1 is designed to operate in the automotive environment. The protection mechanisms allow the device to be robust against many system-level events such as load dump, reverse battery, short-to-ground, and more.

There are two protection features which, if triggered, will cause the switch to automatically disable:

- Thermal Shutdown
- Current Limit

When any of these protections are triggered, the device will enter the FAULT state. In the FAULT state, the fault indication will be available on the SNS pin (see the [Diagnostic Mechanisms](#) section of the data sheet for more details). For version F of the device, the fault will also be indicated on the FLT pin.

The switch is no longer held off and the fault indication is reset when all of the below conditions are met:

- LATCH pin is low
- t_{RETRY} has expired
- All faults are cleared (thermal shutdown, current limit)

Feature Description (continued)

9.3.1.1 Thermal Shutdown

The TPS1HB08-Q1 includes a temperature sensor on the power FET and also within the controller portion of the device. There are two cases that the device will consider to be a thermal shutdown fault:

- $T_{J,FET} > T_{ABS}$
- $(T_{J,FET} - T_{J,controller}) > T_{REL}$

After the fault is detected, the switch will turn off. If $T_{J,FET}$ passes T_{ABS} , the fault is cleared when the switch temperature decreases by the hysteresis value, T_{HYS} . If instead the T_{REL} threshold is exceeded, the fault is cleared after T_{RETRY} passes.

9.3.1.2 Current Limit

When I_{OUT} reaches the current limit threshold, I_{CL} , the channel will switch off immediately. The I_{CL} value will vary with slew rate and a fast current increase that occurs during a powered-on short circuit can temporarily go above the specified I_{CL} value. When the switch is in the FAULT state it will output an output current I_{SNSFH} on the SNS pin and on version F of the device, the fault will also be indicated on the corresponding FLT pin.

During a short circuit event, the device will hit the I_{CL} value that is listed in the Electrical Characteristics table (for the given device version and R_{ILIM}) and then turn the output off to protect the device. The device will register a short circuit event when the output current exceeds I_{CL} , however the measured maximum current may exceed the I_{CL} value due to the TPS1HB08-Q1 deglitch filter and turn-off time. This deglitch time is defined at 3 μ s so therefore use the test setup described in [TPS1HB08-Q1 AEC-Q100-012 Short Circuit Reliability](#) and take 3 μ s before the peak value as the I_{CL} . The device is guaranteed to protect itself during a short circuit event over the nominal supply voltage range (as defined in the Electrical Characteristics table) at 125°C.

On version F of the device, the current limit set point of the device is flat from -40°C to 60°C, and then will linearly decrease until 150°C. This decrease of the current limit is designed to protect the part in even hot temperatures where a short-circuit event causes more damage.

9.3.1.2.1 Current Limit Foldback

Version B and F of the TPS1HB08-Q1 implement a current limit foldback feature that is designed to protect the device in the case of a long-term fault condition. If the device undergoes fault shutdown events (either of thermal shutdown or current limit) seven consecutive times, the current limit will be reduced to half of the original value. The device will revert back to the original current limit threshold if either of the following occurs:

- The device goes to standby mode.
- The switch turns on and turns off without any fault occurring.

Version A do not implement the current limit foldback due to the lower current limit causing less harm during repetitive long-term faults.

9.3.1.2.2 Programmable Current Limit

All versions except F of the TPS1HB08-Q1 include an adjustable current limit. Some applications (for example, incandescent bulbs) will require a high current limit while other applications can benefit from a lower current limit threshold. In general, wherever possible a lower current limit is recommended due to allowing system advantages through:

- Reduced size and cost in current carrying components such as PCB traces and module connectors
- Less disturbance at the power supply (V_{BB} pin) during a short circuit event
- Improved protection of the downstream load

To set the current limit threshold, connect a resistor from I_{LIM} to V_{BB} . The current limit threshold is determined by [Equation 1](#) (R_{ILIM} in k Ω):

$$I_{CL} = K_{CL} / R_{ILIM} \quad (1)$$

The R_{ILIM} range is between 5 k Ω and 25 k Ω . An R_{ILIM} resistor is required, however in the fault case where the pin is floating, grounded, or outside of this range the current limit will default to an internal level that is defined in the [Specifications](#) section of this document. If R_{ILIM} is out of this range, the device cannot guarantee complete short-circuit protection.

Feature Description (continued)

NOTE

Capacitance on the I_{LIM} pin can cause I_{LIM} to go out of range during short circuit events. For accurate current limiting, place R_{ILIM} near to the device with short traces to ensure <5 pF capacitance to GND on the I_{LIM} pin.

For device version F, there is no I_{LIM} pin and the current limit is not adjustable. In this case, the device will current limit at the internal threshold I_{CL} as defined in the [Electrical Characteristics](#) section.

9.3.1.2.3 Undervoltage Lockout (UVLO)

The device monitors the supply voltage V_{BB} to prevent unpredicted behaviors in the event that the supply voltage is too low. When the supply voltage falls down to V_{UVLOF} , the output stage is shut down automatically. When the supply rises up to V_{UVLOR} , the device turns back on.

During an initial ramp of V_{BB} from 0 V at a ramp rate slower than 1 V/ms, V_{EN} pin will have to be held low until V_{BB} is above UVLO threshold (with respect to board ground) and the supply voltage to the device has reliably reached above the UVLO condition. For best operation, ensure that V_{BB} has risen above UVLO before setting the V_{EN} pin to high.

9.3.1.2.4 V_{BB} During Short-to-Ground

When V_{OUT} is shorted to ground, the module power supply (V_{BB}) can have a transient decrease. This is caused by the sudden increase in current flowing through the wiring harness cables. To achieve ideal system behavior, it is recommended that the module maintain $V_{BB} > 3$ V (above the maximum V_{UVLOF}) during V_{OUT} short-to-ground. This is typically accomplished by placing bulk capacitance on the power supply node.

9.3.1.3 Voltage Transients

The TPS1HB08-Q1 device contains two types of voltage clamps which protect the FET against system-level voltage transients. The two different clamps are shown in [Figure 33](#).

The clamp from V_{BB} to GND is primarily used to protect the controller from positive transients on the supply line (for example, ISO7637-2). The clamp from V_{BB} to V_{OUT} is primarily used to limit the voltage across the FET when switching off an inductive load. If the voltage potential from V_{BB} to GND exceeds the V_{BB} clamp level, the clamp will allow current to flow through the device from V_{BB} to GND (Path 2). If the voltage potential from V_{BB} to V_{OUT} exceeds the clamping voltage, the power FET will allow current to flow from V_{BB} to V_{OUT} (Path 3). Additional capacitance from V_{BB} to GND can increase the reliability of the system during ISO 7637 pulse 2 A testing.

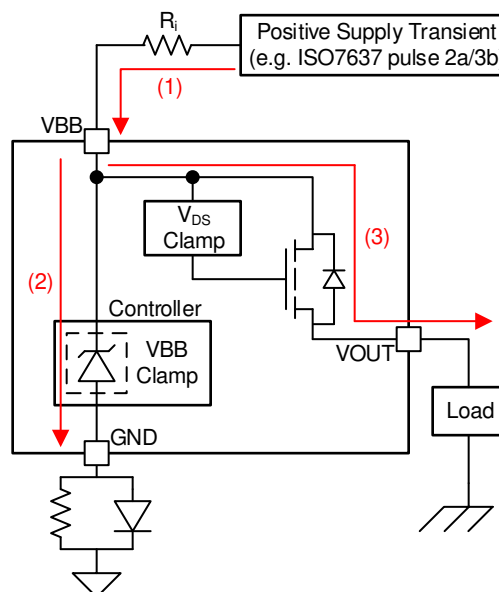

Figure 33. Current Path During Supply Voltage Transient

Feature Description (continued)

9.3.1.3.1 Load Dump

The TPS1HB08-Q1 device is tested according to ISO 16750-2:2010(E) suppressed load dump pulse. The device supports up to 40-V load dump transient and will maintain normal operation during the load dump pulse. If the switch is enabled, it will stay enabled and if the switch is disabled, it will stay disabled.

9.3.1.3.2 Driving Inductive Loads

When switching off an inductive load, the inductor may impose a negative voltage on the output of the switch. The TPS1HB08-Q1 includes a voltage clamp to limit voltage across the FET. The maximum acceptable load inductance is a function of the device robustness. With a 5 mH load, the device can withstand one pulse of 95 mJ inductive dissipation at 125°C and can withstand 56 mJ of one million inductive repetitive pulses with a 10 Hz repetitive pulse. If the application parameters exceed this device limit, it is necessary to use a protection device like a freewheeling diode to dissipate the energy stored in the inductor.

For more information on driving inductive loads, refer to TI's [How To Drive Inductive, Capacitive, and Lighting Loads With Smart High Side Switches](#) application report.

9.3.1.4 Reverse Battery

In the reverse battery condition, the switch will automatically be enabled regardless of the state of EN to prevent excess power dissipation inside the MOSFET body diode. In many applications (for example, resistive loads), the full load current may be present during reverse battery. In order to activate the automatic switch on feature, all NC pins must be grounded to IC ground.

There are two options for blocking reverse current in the system. The first option is to place a blocking device (FET or diode) in series with the battery supply, blocking all current paths. The second option is to place a blocking diode in series with the GND node of the high-side switch. This method will protect the controller portion of the switch (path 2), but it will not prevent current from flowing through the load (path 3). The diode used for the second option may be shared amongst multiple high-side switches.

Path 1 shown in [Figure 34](#) is blocked inside of the device.

Feature Description (continued)

Figure 34. Current Path During Reverse Battery

For more information on reverse battery protection, refer to TI's [Reverse Battery Protection for High Side Switches](#) application note.

9.3.1.5 Fault Event – Timing Diagrams - Version A and B

NOTE

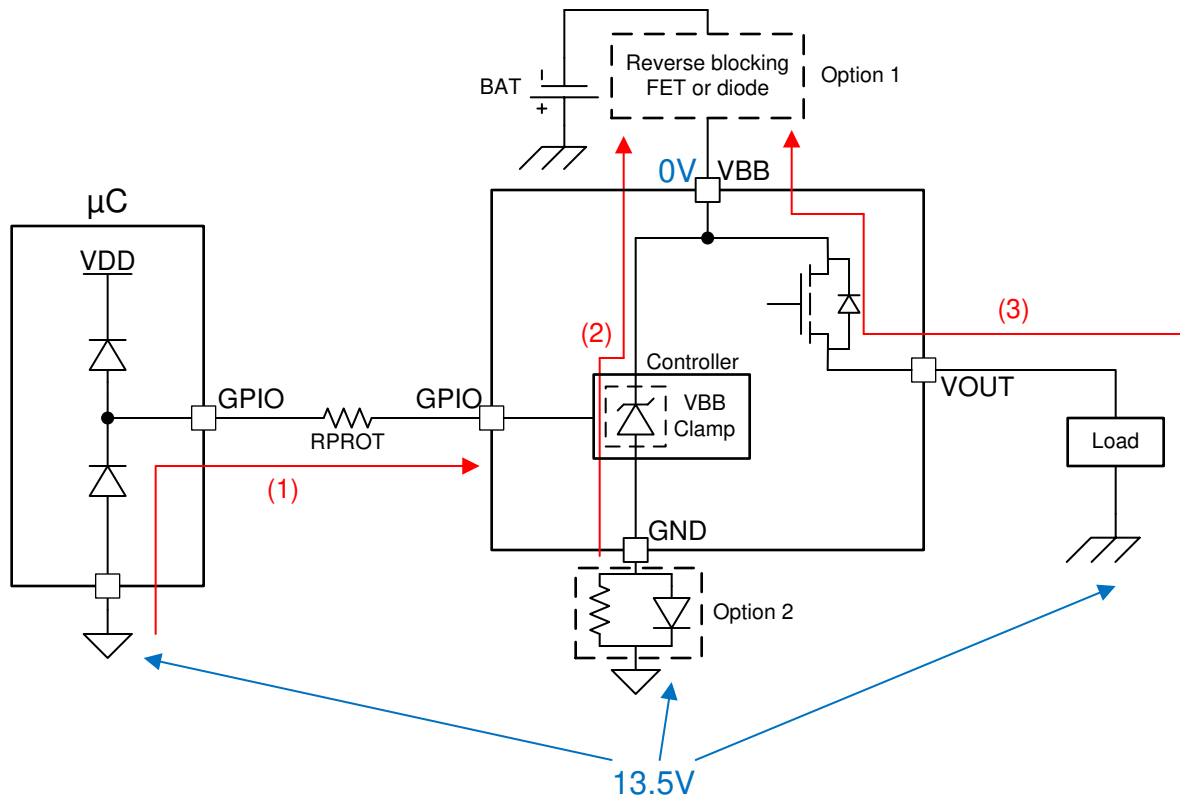
All timing diagrams assume that the SEL1 pin is low.

The LATCH, DIA_EN, and EN pins are controlled by the user. The timing diagrams represent a possible use-case.

Figure 35 shows the immediate current limit switch off behavior. The diagram also illustrates the retry behavior. As shown, the switch will remain latched off until the LATCH pin is low.

Feature Description (continued)

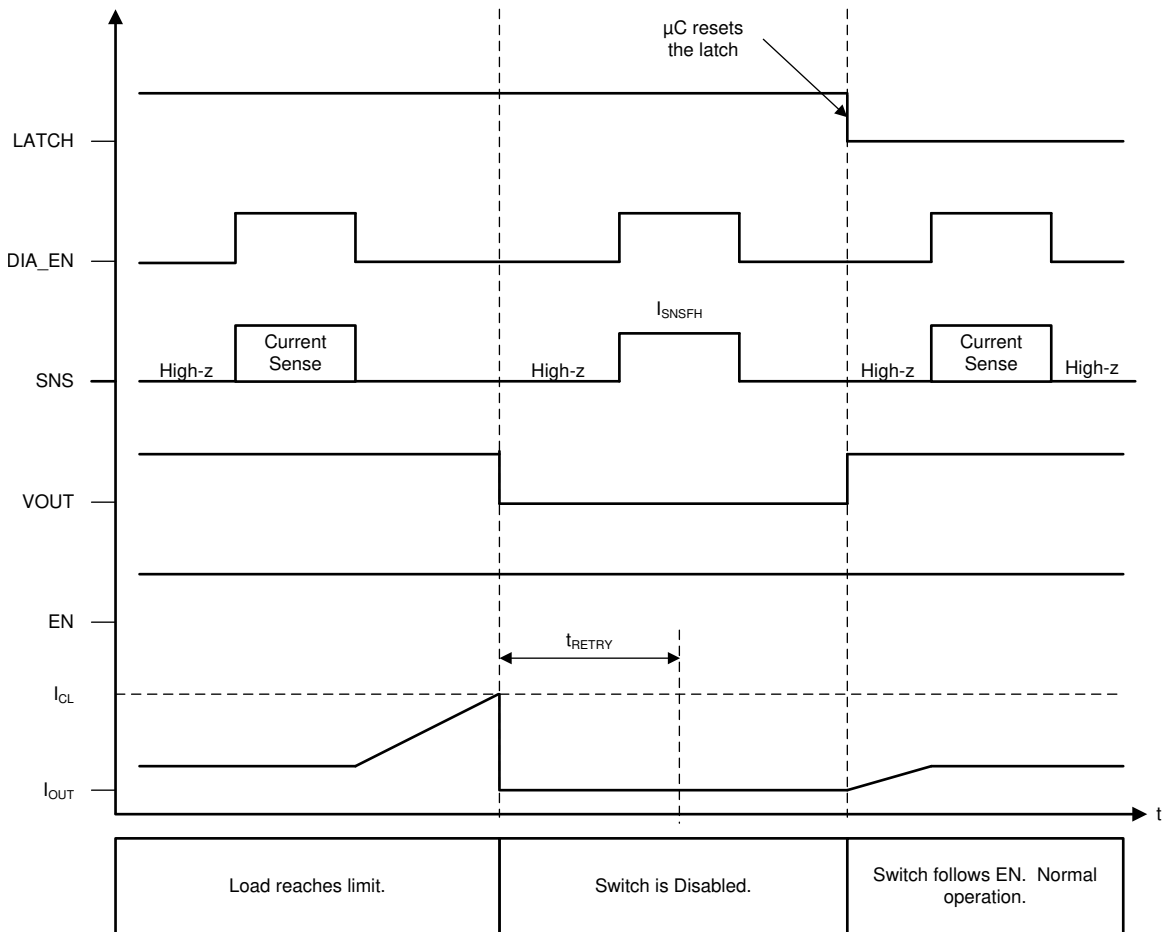

Figure 35. Current Limit – Version A and B - Latched Behavior

Feature Description (continued)

Figure 36 shows the immediate current limit switch off behavior. In this example, LATCH is tied to GND; hence, the switch will retry after the fault is cleared and t_{RETRY} has expired.

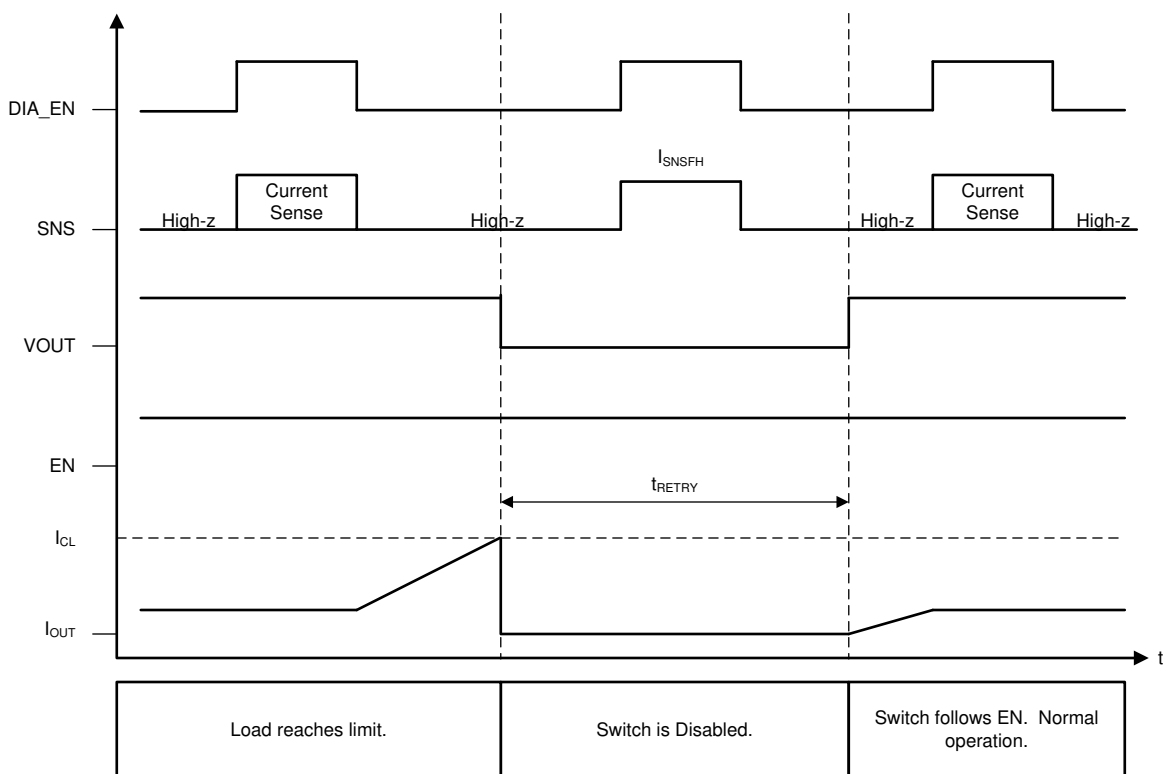

Figure 36. Current Limit - Version A and B - LATCH = 0

When the switch retries after a shutdown event, the SNS fault indication will remain until V_{OUT} has risen to $V_{BB} - 1.8$ V. Once V_{OUT} has risen, the SNS fault indication is reset and current sensing is available. If there is a short-to-ground and V_{OUT} is not able to rise, the SNS fault indication will remain indefinitely. Figure 37 illustrates auto-retry behavior and provides a zoomed-in view of the fault indication during retry.

NOTE

Figure 37 assumes that t_{RETRY} has expired by the time that T_J reaches the hysteresis threshold.

LATCH = 0 V and DIA_EN = 5 V

Feature Description (continued)

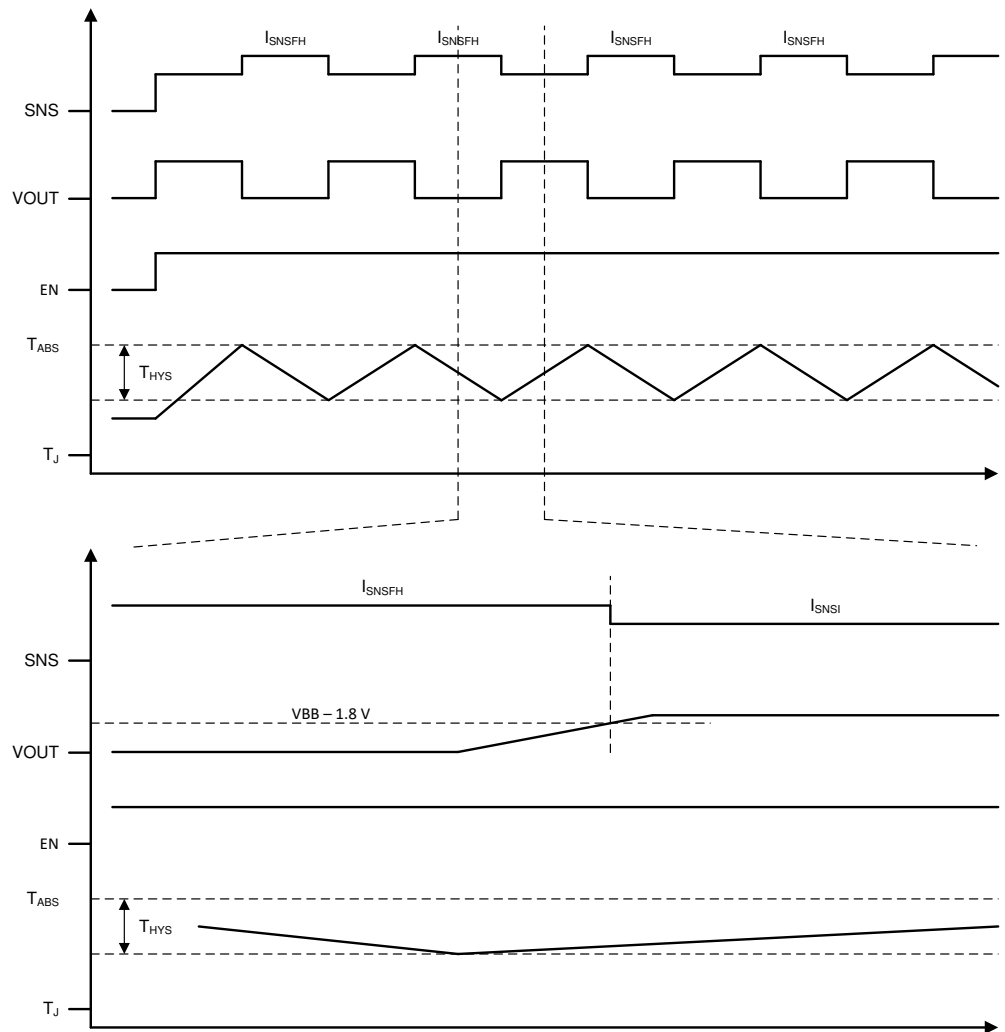

Figure 37. Fault Indication During Retry

9.3.1.6 Fault Event – Timing Diagrams - Version F

TPS1HB08-Q1 device version F will follow the same timing and fault diagrams as described in [Fault Event – Timing Diagrams - Version A and B](#), with the only difference being the behavior of the FLT pin. For each diagram, if version F is used, it will indicate fault in the same cases as the SNS pin. In every diagram, when the SNS pin outputs I_{SNSFH} , the FLT pin will go to an open drain state to indicate fault as well.

9.3.2 Diagnostic Mechanisms

9.3.2.1 VOUT Short-to-Battery and Open-Load

The TPS1HB08-Q1 is capable of detecting short-to-battery and open-load events regardless of whether the switch is turned on or off, however the two conditions use different methods.

9.3.2.1.1 Detection With Switch Enabled

When the switch is enabled, the VOUT short-to-battery and open-load conditions can be detected by the current sense feature. In both cases, the load current will be measured through the SNS pin as below the expected value.

Feature Description (continued)

9.3.2.1.2 Detection With Switch Disabled

While the switch is disabled, if DIA_EN is high, an internal comparator will detect the condition of V_{OUT} . If the load is disconnected (open load condition) or there is a short to battery the V_{OUT} voltage will be higher than the open load threshold ($V_{OL,off}$) and a fault is indicated on the SNS pin and the FLT pin on version F. An internal pull-up of $1\text{ M}\Omega$ is in series with an internal MOSFET switch, so no external component is required if a completely open load must be detected. However, if there is significant leakage or other current draw even when the load is disconnected, a lower value pull-up resistor and switch can be added externally to set the V_{OUT} voltage above the $V_{OL,off}$ during open load conditions.

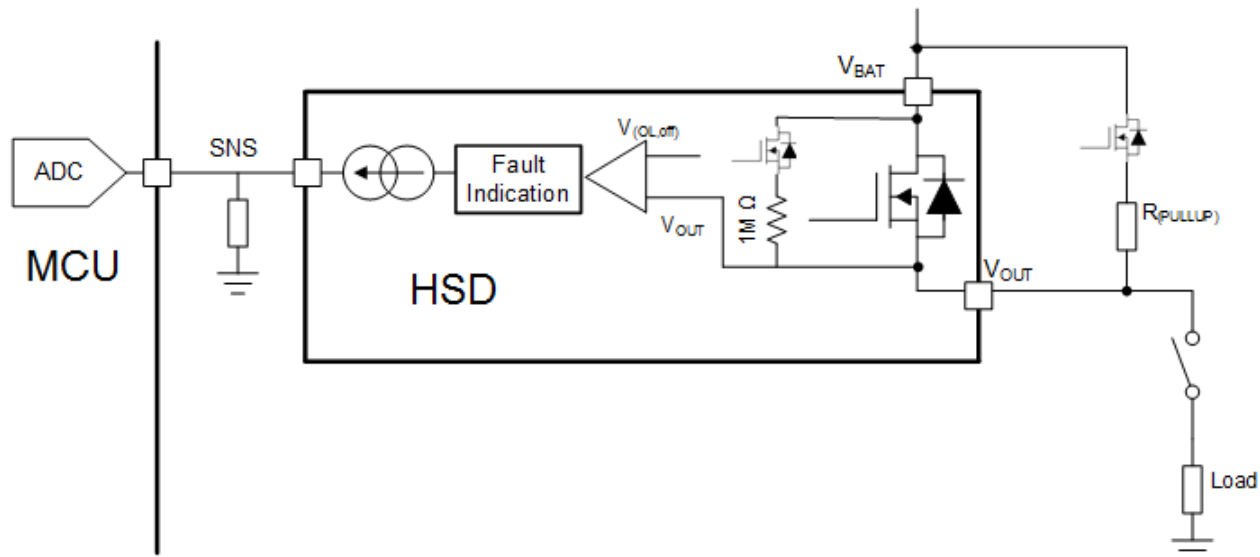

This figure assumes that the device ground and the load ground are at the same potential. In a real system, there may be a ground shift voltage of 1 V to 2 V.

Figure 38. Short to Battery and Open Load Detection

The detection circuitry is only enabled when DIA_EN = HIGH and EN = LOW. If $V_{OUT} > V_{OL}$, the SNS pin will go to the fault level, but if $V_{OUT} < V_{OL}$ there will be no fault indication. The fault indication will only occur if the SEL1 pin is low.

While the switch is disabled and DIA_EN is high, the fault indication mechanisms will continuously represent the present status. For example, if V_{OUT} decreases from greater than V_{OL} to less than V_{OL} , the fault indication is reset. Additionally, the fault indication is reset upon the falling edge of DIA_EN or the rising edge of EN.

Feature Description (continued)

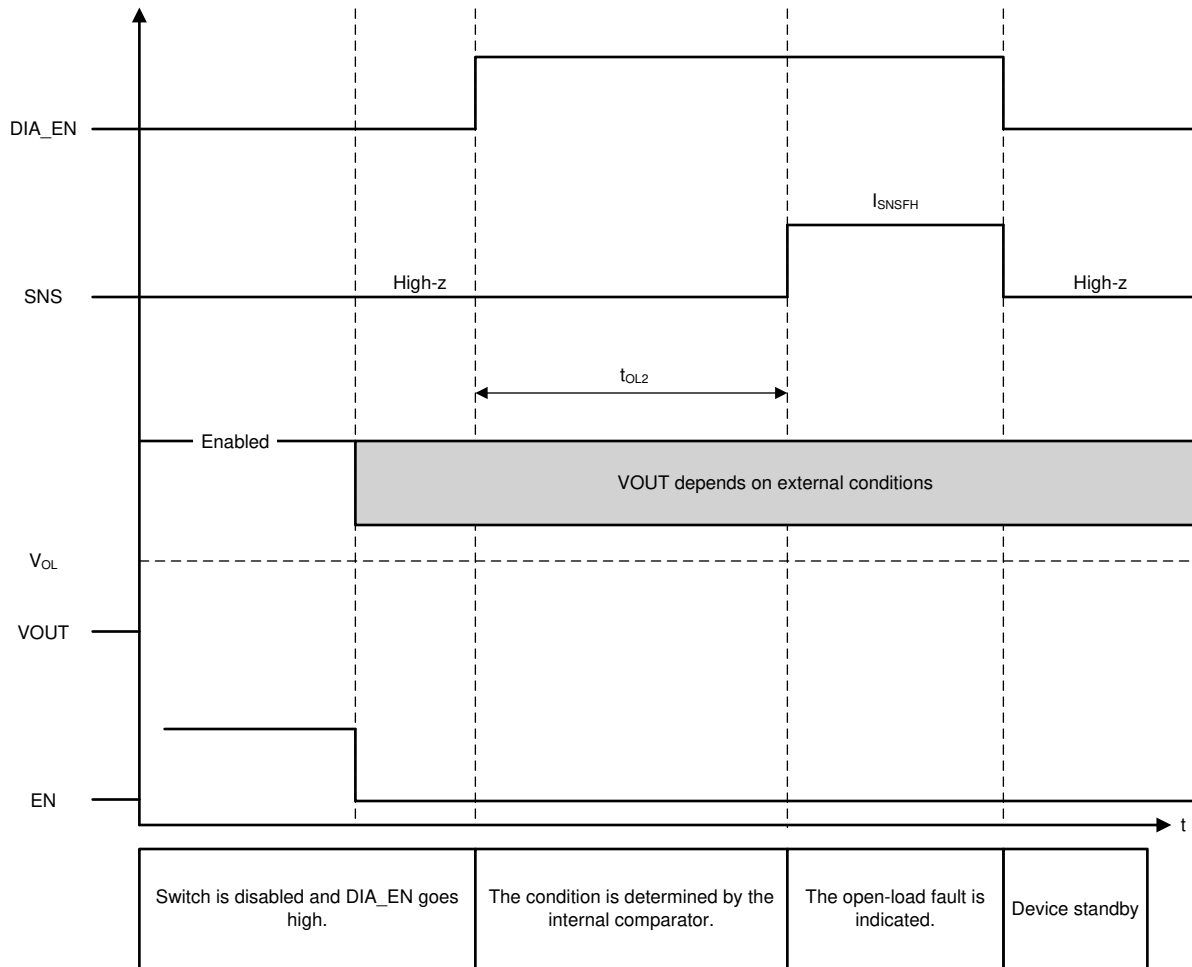

Figure 39. Open Load

9.3.2.2 SNS Output

The SNS output may be used to sense the load current if the SEL1 pin is low and there is no fault or device temperature if the SEL1 pin is high and there is no fault. The sense circuit will provide a current that is proportional to the selected parameter. This current will be sourced into an external resistor to create a voltage that is proportional to the selected parameter. This voltage may be measured by an ADC or comparator. In addition, the SNS pin can be used to measure the FET temperature.

To ensure accurate sensing measurement, the sensing resistor should be connected to the same ground potential as the μ C ADC.

Table 3. Analog Sense Transfer Function

PARAMETER	TRANSFER FUNCTION
Load current	$I_{SNSI} = I_{OUT} / K_{SNS} = I_{OUT} / 5000$
Device temperature	$I_{SNST} = (T_J - 25^\circ\text{C}) \times dI_{SNST} / dT + 0.85$

The SNS output will also be used to indicate system faults. I_{SNS} will go to the predefined level, I_{SNSFH} , when there is a fault. I_{SNSFH} , dI_{SNS}/dT , and K_{SNS} are defined in the [Specifications](#) section.

Device version F does not have the capability to measure device temperature, so can only measure load current.

9.3.2.2.1 R_{SNS} Value

The following factors should be considered when selecting the R_{SNS} value:

- Current sense ratio (K_{SNS})
- Largest and smallest diagnosable load current required for application operation
- Full-scale voltage of the ADC
- Resolution of the ADC

For an example of selecting R_{SNS} value, reference [\$R_{ILIM}\$ Calculation](#) in the applications section of this datasheet.

9.3.2.2.1.1 High Accuracy Load Current Sense

In many automotive modules, it is required that the high-side switch provide diagnostic information about the downstream load. With more complex loads, high accuracy sensing is required. A few examples follow:

- **LED lighting:** In many architectures, the body control module (BCM) must be compatible with both incandescent bulbs and also LED modules. The bulb may be relatively simple to diagnose. However, the LED module will consume less current and also can include multiple LED strings in parallel. The same BCM is used in both cases, so the high-side switch can accurately diagnose both load types.
- **Solenoid protection:** Often solenoids are precisely controlled by low-side switches. However, in a fault event, the low-side switch cannot disconnect the solenoid from the power supply. A high-side switch can be used to continuously monitor several solenoids. If the system current becomes higher than expected, the high-side switch can disable the module.

9.3.2.2.1.2 SNS Output Filter

To achieve the most accurate current sense value, it is recommended to filter the SNS output. There are two methods of filtering:

- Low-Pass RC filter between the SNS pin and the ADC input. This filter is illustrated in [Figure 43](#) with typical values for the resistor and capacitor. The designer should select a C_{SNS} capacitor value based on system requirements. A larger value will provide improved filtering but a smaller value will allow for faster transient response.
- The ADC and microcontroller can also be used for filtering. It is recommended that the ADC collects several measurements of the SNS output. The median value of this data set should be considered as the most accurate result. By performing this median calculation, the microcontroller can filter out any noise or outlier data.

9.3.2.3 Fault Indication and SNS Mux

The following faults will be communicated through the SNS output:

- Switch shutdown, due to:
 - Thermal Shutdown
 - Current limit
- Open-Load and V_{OUT} shorted-to-battery

Open-load and Short-to-battery are not indicated while the switch is enabled, although these conditions can still be detected through the sense current. Hence, if there is a fault indication while the channel is enabled, then it must be either due to an overcurrent or overtemperature event.

The SNS pin will only indicate the fault if the SEL1 pins is low. When the SEL1 pin is high and the device is set to measure temperature, the pin will be measuring the channel FET temperature.

For device version F, the \overline{FLT} pin will pull low when the device is in any of these fault states.

Table 4. Device Version A/B SNS Mux

INPUTS			OUTPUTS
DIA_EN	SEL1	FAULT DETECT ⁽¹⁾	SNS
0	X	X	High-z
1	0	0	Output current
1	1	0	Device temperature
1	0	1	I _{SNSFH}
1	1	1	Device temperature

For device version F, the SEL1 pin has no functionality so the device cannot output a temperature sense current. In this case, SEL1 should be connected to ground through an R_{PROT} resistor and the SNS behavior will follow the table below.

Table 5. Device Version F SNS Mux

INPUTS			OUTPUTS	
DIA_EN	SEL1	FAULT DETECT ⁽¹⁾	SNS	FLT ⁽²⁾
0	X	X	High-z	High-z
1	X	0	Output current	High-z
1	X	1	I _{SNSFH}	Open-drain

9.3.2.4 Resistor Sharing

Multiple high-side devices may use the same SNS resistor as shown in Figure 40. This reduces the total number of passive components in the system and the number of ADC terminals that are required of the microcontroller.

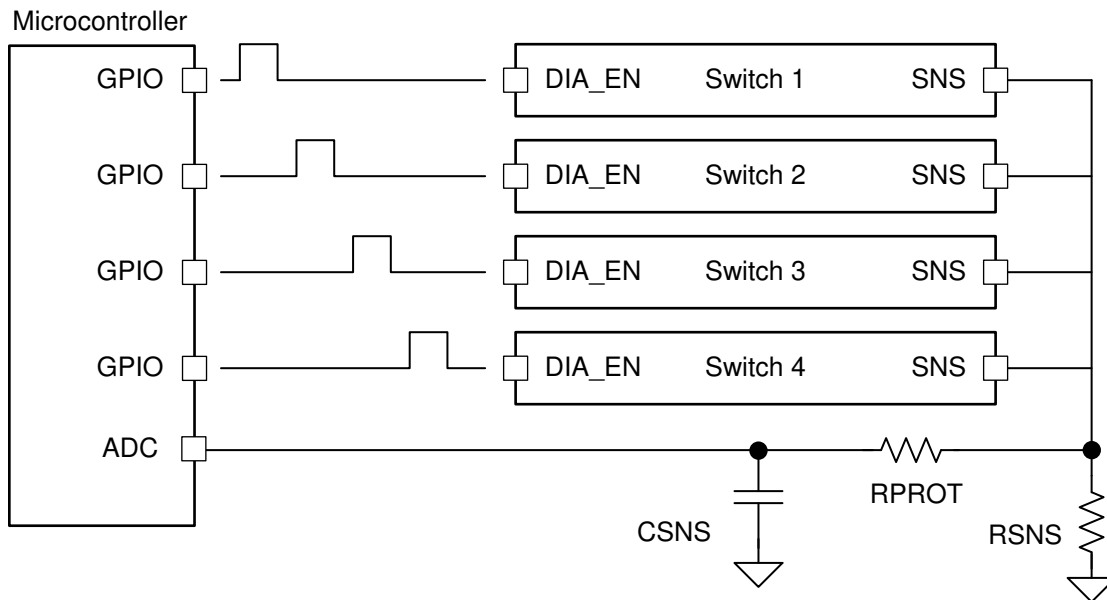

Figure 40. Sharing R_{SNS} Among Multiple Devices

- (1) Fault Detect encompasses multiple conditions:
 - (a) Switch shutdown and waiting for retry
 - (b) Open Load and Short To Battery
- (1) Fault Detect encompasses multiple conditions:
 - (a) Switch shutdown and waiting for retry
 - (b) Open Load / Short To Battery
- (2) Version F Only

9.3.2.5 High-Frequency, Low Duty-Cycle Current Sensing

Some applications will operate with a high-frequency, low duty-cycle PWM or require fast settling of the SNS output. For example, a 250 Hz, 5% duty cycle PWM will have an on-time of only 200 μ s that must be accommodated. The micro-controller ADC may sample the SNS signal after the defined settling time $t_{SNSION3}$.

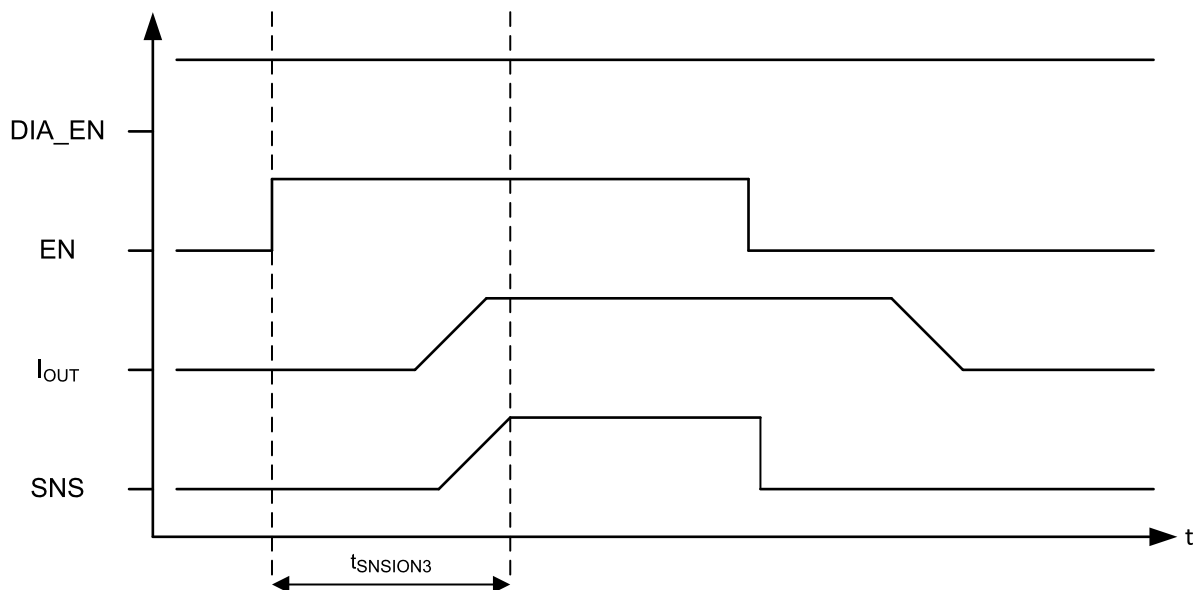

Figure 41. Current Sensing in Low-Duty Cycle Applications

9.4 Device Functional Modes

During typical operation, the TPS1HB08-Q1 can operate in a number of states that are described below and shown as a state diagram in [Figure 42](#).

9.4.1 Off

Off state occurs when the device is not powered.

9.4.2 Standby

Standby state is a low-power mode used to reduce power consumption to the lowest level. Diagnostic capabilities are not available in Standby mode.

9.4.3 Diagnostic

Diagnostic state may be used to perform diagnostics while the switch is disabled.

9.4.4 Standby Delay

The Standby Delay state is entered when EN and DIA_EN are low. After t_{STBY} , if the EN and DIA_EN pins are still low, the device will go to Standby State.

9.4.5 Active

In Active state, the switch is enabled. The diagnostic functions may be turned on or off during Active state.

Device Functional Modes (continued)

9.4.6 Fault

The Fault state is entered if a fault shutdown occurs (thermal shutdown or current limit). After all faults are cleared, the LATCH pin is low, and the retry timer has expired, the device will transition out of Fault state. If the EN pin is high, the switch will re-enable. If the EN pin is low, the switch will remain off.

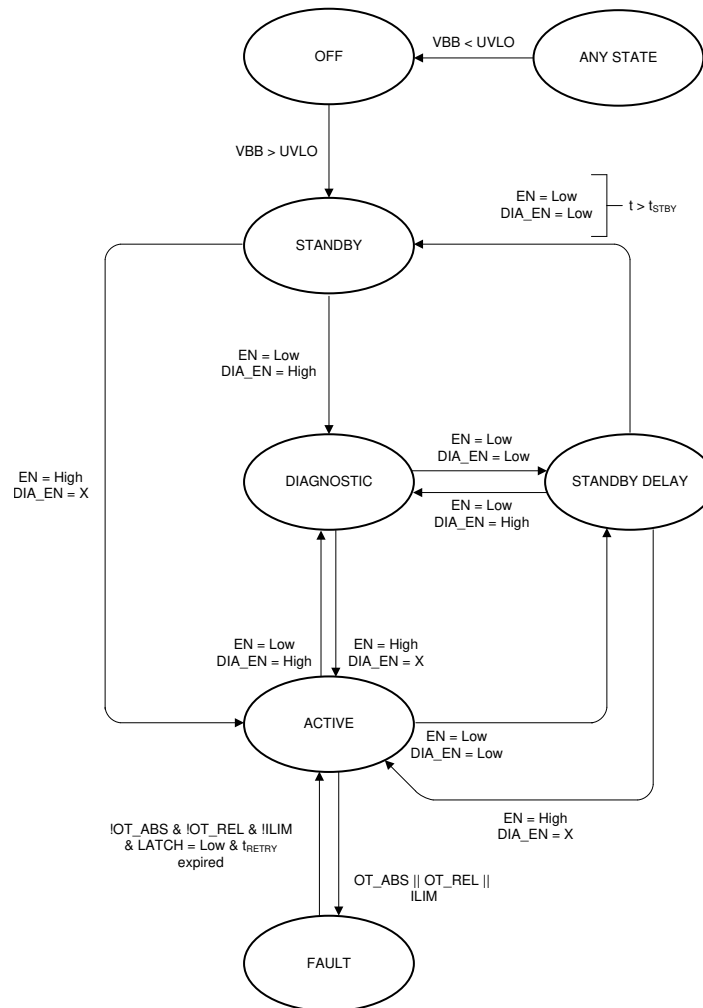

Figure 42. State Diagram

10 Application and Implementation

NOTE

Information in the following applications and implementation sections is not part of the TI component specification, and TI does not warrant its accuracy or completeness. TI's customers are responsible for determining suitability of components for their purposes. Customers should validate and test their design implementation to confirm system functionality.

10.1 Application Information

Figure 43 shows the schematic of a typical application for version A or B of the TPS1HB08-Q1. It includes all standard external components. This section of the datasheet discusses the considerations in implementing commonly required application functionality. Version F of the device will replace the ILIM pin with the open drain FLT pin. In this case, the FLT pin must be connected to a 5 V rail through a 10 kΩ pull up resistor.

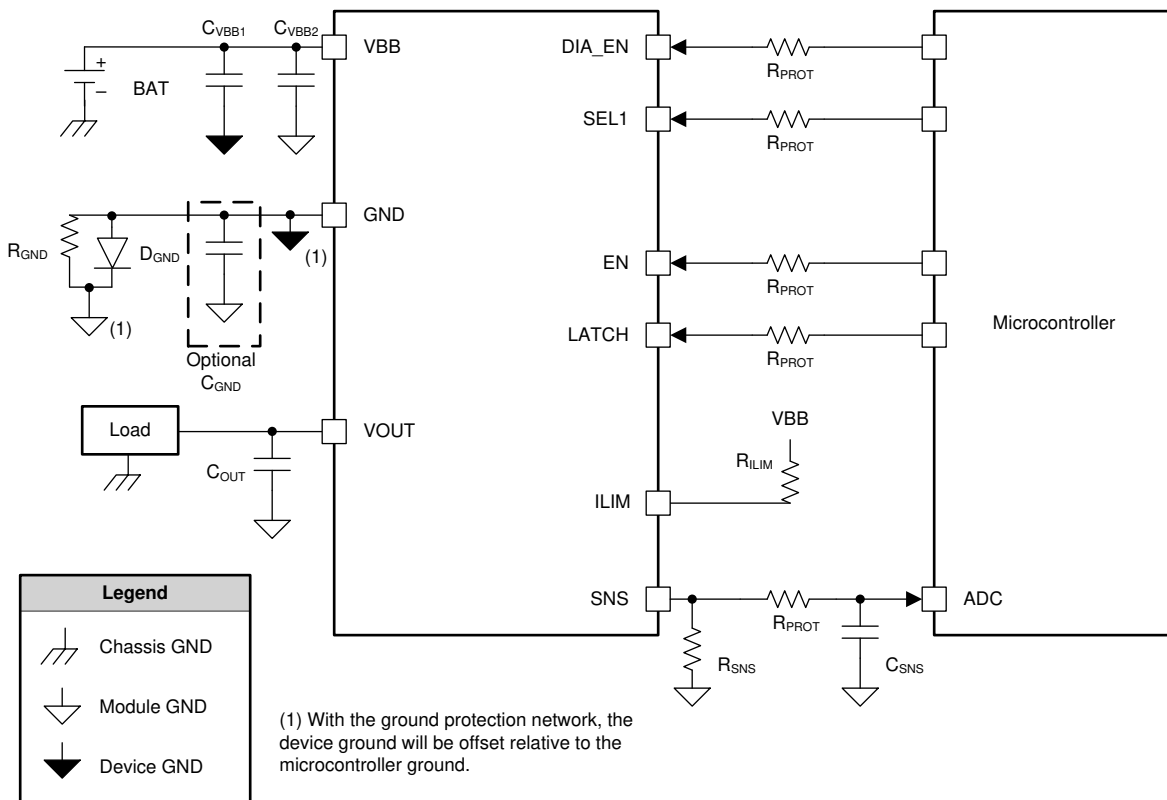

With the ground protection network, the device ground will be offset relative to the microcontroller ground.

Figure 43. System Diagram

Table 6. Recommended External Components

COMPONENT	TYPICAL VALUE	PURPOSE
R _{PROT}	15 kΩ	Protect microcontroller and device I/O pins
R _{SNS}	1 kΩ	Translate the sense current into sense voltage
C _{SNS}	100 pF - 10 nF	Low-pass filter for the ADC input
R _{GND}	4.7 kΩ	Stabilize GND potential during turn-off of inductive load
D _{GND}	BAS21 Diode	Protects device during reverse battery
R _{ILIM}	5 kΩ - 25 kΩ	Set current limit threshold
C _{VBB1}	4.7 nF to Device GND	Filtering of voltage transients (for example, ESD, ISO7637-2) and improved emissions

Application Information (continued)

Table 6. Recommended External Components (continued)

COMPONENT	TYPICAL VALUE	PURPOSE
C _{VBB2}	220 nF to Module GND	Stabilize the input supply and filter out low frequency noise.
C _{OUT}	220 nF	Filtering of voltage transients (for example, ESD, ISO7637-2)

10.1.1 Ground Protection Network

As discussed in the [Reverse Battery](#) section, D_{GND} may be used to prevent excessive reverse current from flowing into the device during a reverse battery event. Additionally, R_{GND} is placed in parallel with D_{GND} if the switch is used to drive an inductive load. The ground protection network (D_{GND} and R_{GND}) may be shared amongst multiple high-side switches.

A minimum value for R_{GND} may be calculated by using the absolute maximum rating for I_{GND}. During the reverse battery condition, I_{GND} = V_{BB} / R_{GND}:

$$R_{GND} \geq V_{BB} / I_{GND}$$

- Set V_{BB} = -13.5 V
- Set I_{GND} = -50 mA (absolute maximum rating)

$$R_{GND} \geq -13.5 \text{ V} / -50 \text{ mA} = 270 \text{ } \Omega \quad (2)$$

In this example, it is found that R_{GND} must be at least 270 Ω. It is also necessary to consider the power dissipation in R_{GND} during the reverse battery event:

$$P_{RGND} = V_{BB}^2 / R_{GND} \quad (3)$$

$$P_{RGND} = (13.5 \text{ V})^2 / 270 \text{ } \Omega = 0.675 \text{ W}$$

In practice, R_{GND} may not be rated for such a high power. In this case, a larger resistor value should be selected.

10.1.2 Interface With Microcontroller

The ground protection network will cause the device ground to be at a higher potential than the module ground (and microcontroller ground). This offset will impact the interface between the device and the microcontroller.

Logic pin voltage will be offset by the forward voltage of the diode. For input pins (for example, EN), the designer must consider the V_{IH} specification of the switch and the V_{OH} specification of the microcontroller. For a system that *does not* include D_{GND}, it is required that V_{OH} > V_{IH}. For a system that *does* include D_{GND}, it is required that V_{OH} > (V_{IH} + V_F). V_F is the forward voltage of D_{GND}.

The sense resistor, R_{SNS}, should be terminated to the microcontroller ground. In this case, the ADC can accurately measure the SNS signal even if there is an offset between the microcontroller ground and the device ground.

10.1.3 I/O Protection

R_{PROT} is used to protect the microcontroller I/O pins during system-level voltage transients such as ISO pulses or reverse battery. The SNS pin voltage can exceed the ADC input pin maximum voltage if the fault or saturation current causes a high enough voltage drop across the sense resistor. If that can occur in the design (for example, by switching to a high value R_{SNS} to improve ADC input level), then an appropriate external clamp has to be designed to prevent a high voltage at the SNS output and the ADC input.

10.1.4 Inverse Current

Inverse current occurs when 0 V < V_{BB} < V_{OUT}. In this case, current may flow from V_{OUT} to V_{BB}. Inverse current cannot be caused by a purely resistive load. However, a capacitive or inductive load can cause inverse current. For example, if there is a significant amount of load capacitance and the V_{BB} node has a transient droop, V_{OUT} may be greater than V_{BB}.

The TPS1HB08-Q1 will not detect inverse current. When the switch is enabled, inverse current will pass through the switch. When the switch is disabled, inverse current may pass through the MOSFET body diode. The device will continue operating in the normal manner during an inverse current event.

10.1.5 Loss of GND

The ground connection may be lost either on the device level or on the module level. If the ground connection is lost, the switch will be disabled. If the switch was already disabled when the ground connection was lost, the switch will remain disabled. When the ground is reconnected, normal operation will resume.

10.1.6 Automotive Standards

The TPS1HB08-Q1 is designed to be protected against all relevant automotive standards to ensure reliable operations when connected to a 12-V automotive battery.

10.1.6.1 ISO7637-2

The TPS1HB08-Q1 is tested according to the ISO7637-2:2011 (E) standard. The test pulses are applied both with the switch enabled and disabled. The test setup includes only the DUT and minimal external components: C_{VBB} , C_{OUT} , D_{GND} , and R_{GND} .

Status II is defined in ISO 7637-1 Function Performance Status Classification (FPSC) as: “The function does not perform as designed during the test but returns automatically to normal operation after the test”. See [Table 7](#) for ISO7637-2:2011 (E) expected results.

Table 7. ISO7637-2:2011 (E) Results

TEST PULSE	TEST PULSE SEVERITY LEVEL WITH STATUS II FUNCTIONAL PERFORMANCE		MINIMUM NUMBER OF PULSES OR TEST TIME	BURST CYCLE / PULSE REPETITION TIME	
	LEVEL	US		MIN	MAX
1	III	-112 V	500 pulses	0.5 s	--
2a ⁽¹⁾	III	+55 V	500 pulses	0.20	5 s
2b	IV	+10 V	10 pulses	0.5 s	5 s
3a	IV	-220 V	1 hour	90 ms	100 ms
3b	IV	+150 V	1 hour	90 ms	100 ms

(1) 1 μ F capacitance on C_{VBB} is required for passing level 3 ISO7637 pulse 2 A.

10.1.6.2 TPS1HB08-Q1 AEC-Q100-012 Short Circuit Reliability

The TPS1HB08-Q1 is tested according to the AEC-Q100-012 Short Circuit Reliability standard. This test is performed to demonstrate the robustness of the device against V_{OUT} short-to-ground events. Test conditions and test procedures are summarized in . For further details, refer to the AEC-Q100-012 standard document.

Test conditions:

- LATCH = 0 V
- 10 units from 3 separate lots for a total of 30 units.
- $L_{supply} = 5 \mu H$, $R_{supply} = 10 m\Omega$
- $V_{BB} = 14 V$

Test procedure:

- Parametric data is collected on each unit pre-stress
- Each unit is enabled into a short-circuit with the required short circuit cycles or duration as specified
- Functional testing is performed on each unit post-stress to verify that the part still operates as expected

The cold repetitive test is run at 85°C which is the worst case condition for the device to sustain a short circuit. The cold repetitive test refers to the device being given time to cool down between pulses, rather than being run at a cold temperature. The load short circuit is the worst case situation, since the energy stored in the cable inductance can cause additional harm. The fast response of the device ensures current limiting occurs quickly and at a current close to the load short condition. In addition, the hot repetitive test is performed as well.

Table 8. AEC-Q100-012 Test Results

TEST	LOCATION OF SHORT	DEVICE VERSION	NO. OF CYCLES / DURATION	NO. OF UNITS	NO. OF FAILS
Cold Repetitive - Long Pulse	Load Short Circuit, $L_{short} = 5 \mu H$, $R_{short} = 50 m\Omega$, $T_A = -40^\circ C$	F	100 k cycles	30	0
Cold Repetitive - Long Pulse - Load Short ⁽¹⁾	Load Short Circuit, $L_{short} = 5 \mu H$, $R_{short} = 200 m\Omega$, $T_A = 85^\circ C$	F	100 k cycles	30	0
Cold Repetitive - Long Pulse - Load Short ⁽¹⁾	Load Short Circuit, $L_{short} = 5 \mu H$, $R_{short} = 200 m\Omega$, $T_A = -40^\circ C$	F	100 k cycles	30	0
Cold Repetitive - Long Pulse - Terminal Short	Load Short Circuit, $L_{short} < 1 \mu H$, $R_{short} < 20 m\Omega$, $T_A = 85^\circ C$	F	100 k cycles	30	0
Hot Repetitive - Long Pulse	Load Short Circuit, $L_{short} = 5 \mu H$, $R_{short} = 100 m\Omega$, $T_A = 25^\circ C$	F	100 hours	30	0

(1) For Cold Repetitive short, 200 mΩ R_{short} is used so that the device is at a higher junction temperature before the short circuit event, increasing the harshness of the test.

10.1.7 Thermal Information

When outputting current, the TPS1HB08-Q1 will heat up due to the power dissipation. The transient thermal impedance curve can be used to determine the device temperature during a pulse of a given length. This $Z_{\theta JA}$ value corresponds to a JEDEC standard 2s2p thermal test PCB with thermal vias.

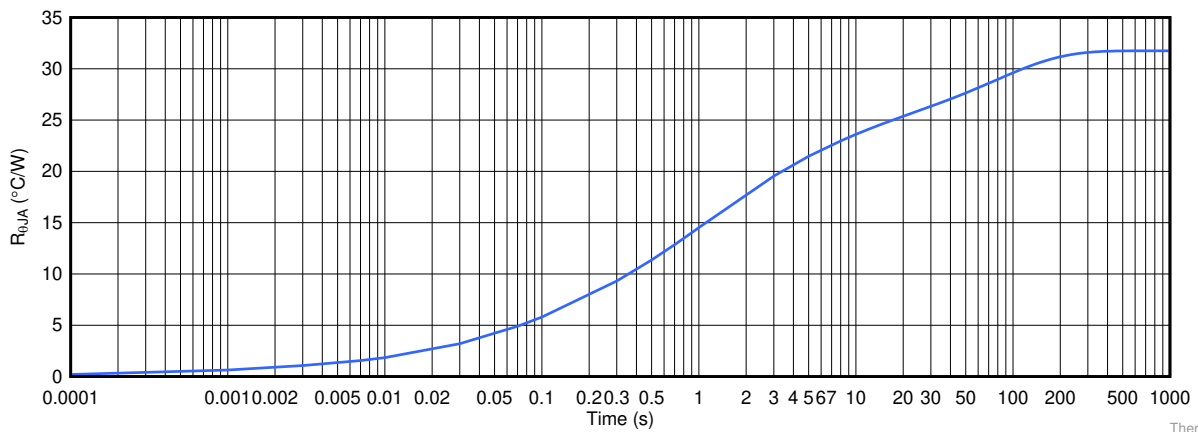
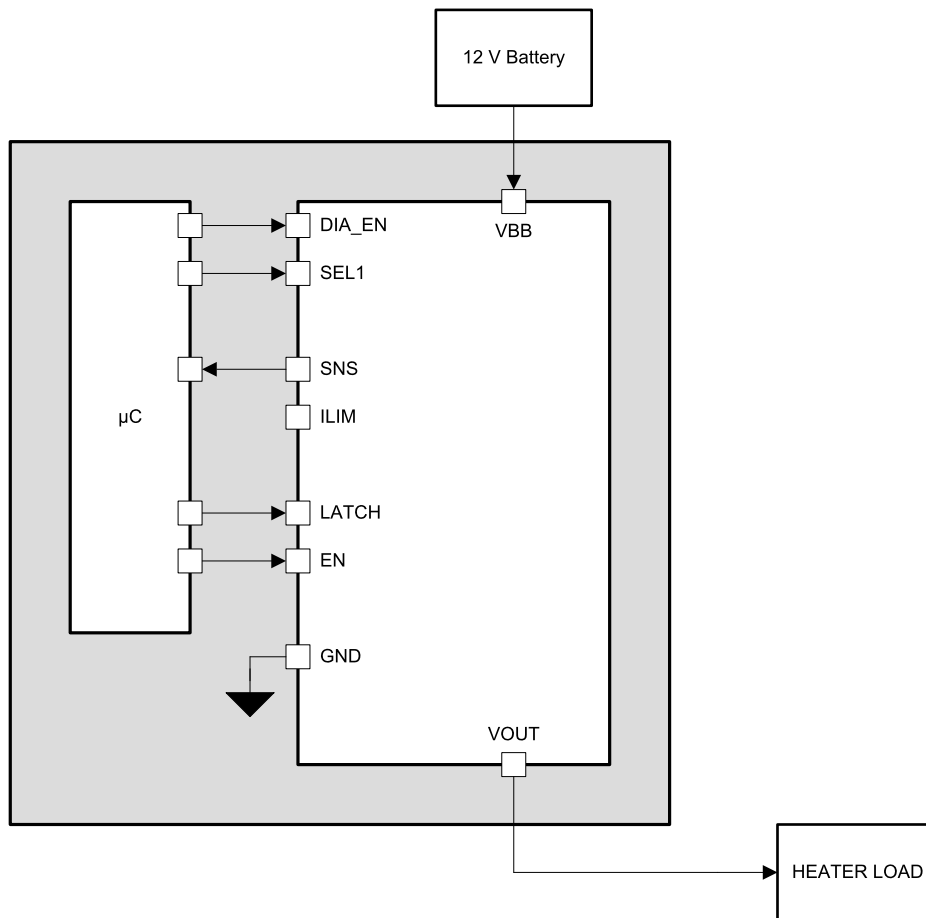

Figure 44. TPS1HB08-Q1 Transient Thermal Impedance

10.2 Typical Application

This application example demonstrates how the TPS1HB08-Q1 device can be used to power resistive heater loads in automotive seats. In this example, we consider a heater load that is powered by the device. This is just one example of the many applications where this device can fit.

Typical Application (continued)

Figure 45. Block Diagram for Powering Heater Load
10.2.1 Design Requirements

For this design example, use the input parameters shown in [Table 9](#).

Table 9. Design Parameters

DESIGN PARAMETER	EXAMPLE VALUE
V_{BB}	13.5 V
Load - Heater	130 W max
Load Current Sense	100 mA to 20 A
I_{LIM}	12 A
Ambient temperature	70°C
$R_{\theta JA}$	32.6°C/W (depending on PCB)
Device Version	A

10.2.2 Detailed Design Procedure
10.2.2.1 Thermal Considerations

The 130 W heater load will cause a DC current in the channel under maximum load power condition of around 9.6 A. Therefore, this current at 13.5 V will assume worst case heating.

Power dissipation in the switch is calculated in [Equation 4](#). R_{ON} is assumed to be 16 mΩ because this is the maximum specification at high temperature. In practice, R_{ON} will almost always be lower.

$$P_{FET} = I^2 \times R_{ON} \quad (4)$$

$$P_{FET} = (9.6 \text{ A})^2 \times 16 \text{ m}\Omega = 1.47 \text{ W} \quad (5)$$

This means that the maximum FET power dissipation is 1.47 W. The junction temperature of the device can be calculated using [Equation 6](#) and the $R_{\theta JA}$ value from the [Specifications](#) section.

$$T_J = T_A + R_{\theta JA} \times P_{FET} \quad (6)$$

$$T_J = 70^\circ\text{C} + 32.6^\circ\text{C/W} \times 1.47 \text{ W} = 117.9^\circ\text{C}$$

The maximum junction temperature rating for the TPS1HB08-Q1 is $T_J = 150^\circ\text{C}$. Based on the above example calculation, the device temperature will stay below the maximum rating even at this high level of current.

10.2.2.2 R_{ILIM} Calculation

In this application, the TPS1HB08-Q1 must allow for the maximum DC current with margin but minimize the energy in the switch during a fault condition by minimizing the current limit. For this application, the best I_{LIM} set point is approximately 12 A. [Equation 7](#) allows you to calculate the R_{ILIM} value that is placed from the I_{LIM} pins to V_{BB} . R_{ILIM} is calculated in $k\Omega$.

$$R_{ILIM} = K_{CL} / I_{CL} \quad (7)$$

Because this device is version A, the K_{CL} value in the [Specifications](#) section is $160 \text{ A} \times k\Omega$.

$$R_{ILIM} = 160 (\text{A} \times k\Omega) / 12 \text{ A} = 13.3 \text{ k}\Omega \quad (8)$$

For a I_{LIM} of 12 A, the R_{ILIM} value should be set at around 13.3 $k\Omega$

10.2.2.3 Diagnostics

If the resistive heating load is disconnected (heater malfunction), an alert is desired. Open-load detection can be performed in the switch-enabled state with the current sense feature of the TPS1HB08-Q1 device. Under open load condition, the current in the SNS pin will be the fault current and the can be detected from the sense voltage measurement.

10.2.2.3.1 Selecting the R_{SNS} Value

[Table 10](#) shows the requirements for the load current sense in this application. The K_{SNS} value is specified for the device and can be found in the [Specifications](#) section.

Table 10. R_{SNS} Calculation Parameters

PARAMETER	EXAMPLE VALUE
Current Sense Ratio (K_{SNS})	5000
Largest diagnosable load current	20 A
Smallest diagnosable load current	100 mA
Full-scale ADC voltage	5 V
ADC resolution	10 bit

The load current measurement requirements of 20 A ensures that even in the event of a overcurrent surpassing the set current limit, the MCU can register and react by shutting down the TPS1HB08-Q1, while the low level of 100 mA allows for accurate measurement of low load currents.

The R_{SNS} resistor value should be selected such that the largest diagnosable load current puts V_{SNS} at about 95% of the ADC full-scale. With this design, any ADC value above 95% can be considered a fault. Additionally, the R_{SNS} resistor value should ensure that the smallest diagnosable load current does not cause V_{SNS} to fall below 1 LSB of the ADC. With the given example values, a 1.2-k Ω sense resistor satisfies both requirements shown in [Table 11](#).

Table 11. V_{SNS} Calculation

LOAD (A)	SENSE RATIO	I_{SNS} (mA)	R_{SNS} (Ω)	V_{SNS} (V)	% of 5-V ADC
0.1	5000	0.02	1200	0.024	0.5%
20	5000	4	1200	4.800	96.0%

10.3 Typical Application

This application example demonstrates how the TPS1HB08-Q1 device can be used to power bulb loads in automotive headlights. In this example, we consider a 65 W bulb that is powered by the device. This is just one example of the many applications where this device can fit.

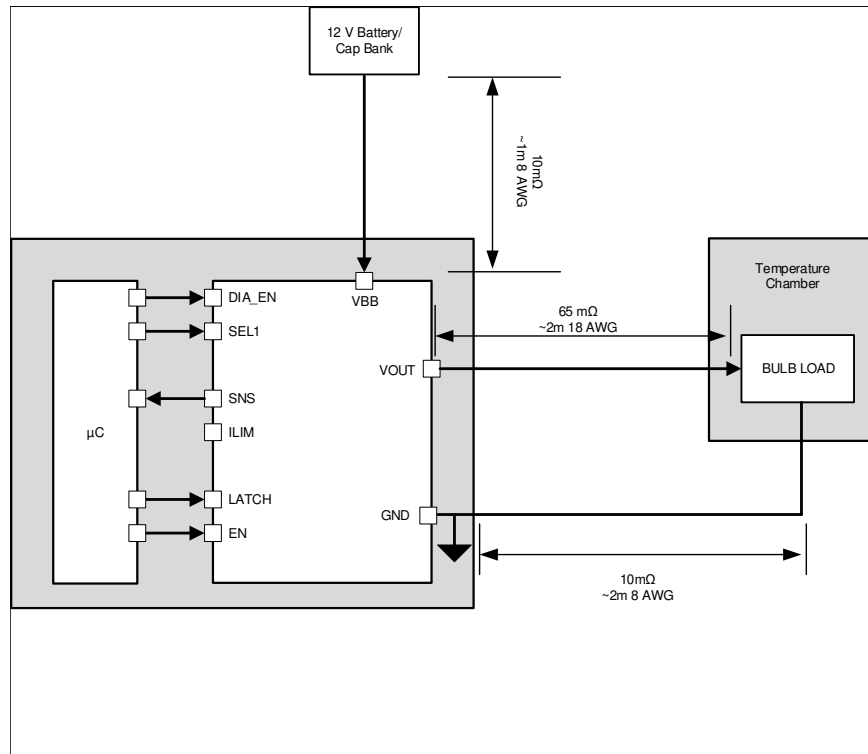

Figure 46. Block Diagram for Driving Bulb Load

10.3.1 Design Requirements

For this design example, use the input parameters shown in [Table 12](#).

Table 12. Design Parameters

DESIGN PARAMETER	EXAMPLE VALUE
V_{BB}	16 V
Load - Bulb	65 W W max
Fixed I_{LIM}	94 A
Ambient temperature	25°C
Bulb Temperature in Chamber	-40°C
Cable Impedance from Device to Bulb	65 mΩ
Device Version	F

10.3.2 Detailed Design Procedure

The typical bulb test setup is where the device is at 25°C and the bulb is in a temperature chamber at -40°C. The bulb needs to be kept at -40°C so that the impedance is very low and the inrush current will be the highest. The impedance of the cables is important because it will change the inrush current of the bulb as well. The F version of the TPS1HB08-Q1 has a very high fixed current limit so that the inrush current of the bulb can be passed without limitation.

10.3.3 Application Curves

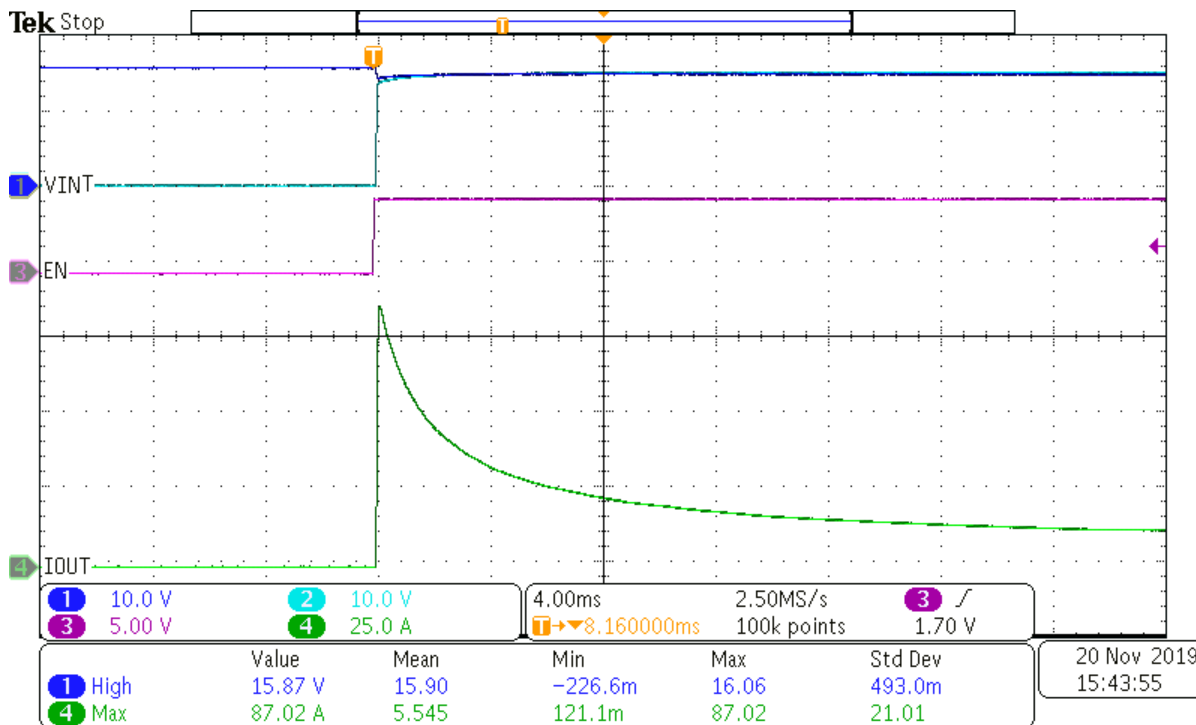

Figure 47. TPS1HB08-Q1 Version F 65W Bulb Turn On

11 Power Supply Recommendations

The TPS1HB08-Q1 device is designed to operate in a 12-V automotive system. The nominal supply voltage range is 6 V to 18 V as measured at the V_{BB} pin with respect to the GND pin of the device. In this range the device meets full parametric specifications as listed in the [Electrical Characteristics](#) table. The device is also designed to withstand voltage transients beyond this range. When operating outside of the nominal voltage range but within the operating voltage range, the device will exhibit normal functional behavior. However, parametric specifications may not be specified outside the nominal supply voltage range.

Table 13. Operating Voltage Range

V_{BB} Voltage Range	Note
3 V to 6 V	Transients such as cold crank and start-stop, functional operation are specified but some parametric specifications may not apply. The device is completely short-circuit protected up to 125°C
6 V to 18 V	Nominal supply voltage, all parametric specifications apply. The device is completely short-circuit protected up to 125°C
18 V to 40 V	Transients such as jump-start and load-dump, functional operation specified but some parametric specifications may not apply

12 Layout

12.1 Layout Guidelines

To achieve optimal thermal performance, connect the exposed pad to a large copper pour. On the top PCB layer, the pour may extend beyond the package dimensions as shown in the example below. In addition to this, it is recommended to also have a V_{BB} plane either on one of the internal PCB layers or on the bottom layer.

Vias should connect this plane to the top V_{BB} pour.

Ensure that all external components are placed close to the pins. Device current limiting performance can be harmed if the R_{ILIM} is far from the pins and extra parasitics are introduced.

12.2 Layout Example

The layout example is for device versions A/B. For device version F, the ILIM pin will be replaced by the \overline{FLT} pin.

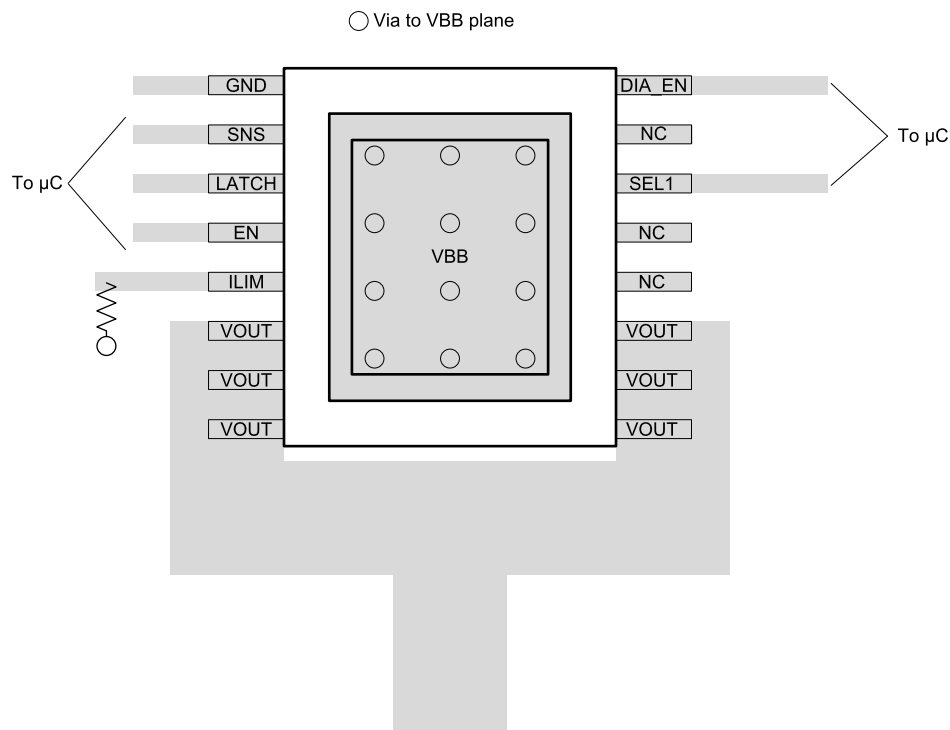

Figure 48. 16-PWP Layout Example

13 Device and Documentation Support

13.1 Documentation Support

13.1.1 Related Documentation

For related documentation see the following:

- TI's [How To Drive Inductive, Capacitive, and Lighting Loads with Smart High Side Switches](#)
- TI's [Short-Circuit Reliability Test for Smart Power Switch](#)
- TI's [Reverse Battery Protection for High Side Switches](#)
- TI's [Adjustable Current Limit of Smart Power Switches](#)

13.2 Receiving Notification of Documentation Updates

To receive notification of documentation updates, navigate to the device product folder on ti.com. In the upper right corner, click on *Alert me* to register and receive a weekly digest of any product information that has changed. For change details, review the revision history included in any revised document.

13.3 Support Resources

TI E2E™ [support forums](#) are an engineer's go-to source for fast, verified answers and design help — straight from the experts. Search existing answers or ask your own question to get the quick design help you need.

Linked content is provided "AS IS" by the respective contributors. They do not constitute TI specifications and do not necessarily reflect TI's views; see TI's [Terms of Use](#).

13.4 Trademarks

E2E is a trademark of Texas Instruments.

All other trademarks are the property of their respective owners.

13.5 Electrostatic Discharge Caution



This integrated circuit can be damaged by ESD. Texas Instruments recommends that all integrated circuits be handled with appropriate precautions. Failure to observe proper handling and installation procedures can cause damage.

ESD damage can range from subtle performance degradation to complete device failure. Precision integrated circuits may be more susceptible to damage because very small parametric changes could cause the device not to meet its published specifications.

13.6 Glossary



[SLYZ022](#) — *TI Glossary*.

This glossary lists and explains terms, acronyms, and definitions.

14 Mechanical, Packaging, and Orderable Information

The following pages include mechanical, packaging, and orderable information. This information is the most current data available for the designated devices. This data is subject to change without notice and revision of this document. For browser-based versions of this data sheet, refer to the left-hand navigation.

PACKAGING INFORMATION

Orderable Device	Status (1)	Package Type	Package Drawing	Pins	Package Qty	Eco Plan (2)	Lead finish/ Ball material (6)	MSL Peak Temp (3)	Op Temp (°C)	Device Marking (4/5)	Samples
TPS1HB08AQPWPRQ1	ACTIVE	HTSSOP	PWP	16	3000	RoHS-Exempt & Green	NIPDAU	Level-3-260C-168HRS	-40 to 125	1HB08A	
TPS1HB08BQPWPRQ1	ACTIVE	HTSSOP	PWP	16	3000	RoHS-Exempt & Green	NIPDAU	Level-3-260C-168HRS	-40 to 125	1HB08B	
TPS1HB08FQPWPRQ1	ACTIVE	HTSSOP	PWP	16	3000	RoHS-Exempt & Green	NIPDAU	Level-3-260C-168HRS	-40 to 125	1HB08F	

(1) The marketing status values are defined as follows:

ACTIVE: Product device recommended for new designs.

LIFEBUY: TI has announced that the device will be discontinued, and a lifetime-buy period is in effect.

NRND: Not recommended for new designs. Device is in production to support existing customers, but TI does not recommend using this part in a new design.

PREVIEW: Device has been announced but is not in production. Samples may or may not be available.

OBSELETE: TI has discontinued the production of the device.

(2) **RoHS:** TI defines "RoHS" to mean semiconductor products that are compliant with the current EU RoHS requirements for all 10 RoHS substances, including the requirement that RoHS substance do not exceed 0.1% by weight in homogeneous materials. Where designed to be soldered at high temperatures, "RoHS" products are suitable for use in specified lead-free processes. TI may reference these types of products as "Pb-Free".

RoHS Exempt: TI defines "RoHS Exempt" to mean products that contain lead but are compliant with EU RoHS pursuant to a specific EU RoHS exemption.

Green: TI defines "Green" to mean the content of Chlorine (Cl) and Bromine (Br) based flame retardants meet JS709B low halogen requirements of <=1000ppm threshold. Antimony trioxide based flame retardants must also meet the <=1000ppm threshold requirement.

(3) MSL, Peak Temp. - The Moisture Sensitivity Level rating according to the JEDEC industry standard classifications, and peak solder temperature.

(4) There may be additional marking, which relates to the logo, the lot trace code information, or the environmental category on the device.

(5) Multiple Device Markings will be inside parentheses. Only one Device Marking contained in parentheses and separated by a "~" will appear on a device. If a line is indented then it is a continuation of the previous line and the two combined represent the entire Device Marking for that device.

(6) Lead finish/Ball material - Orderable Devices may have multiple material finish options. Finish options are separated by a vertical ruled line. Lead finish/Ball material values may wrap to two lines if the finish value exceeds the maximum column width.

Important Information and Disclaimer:The information provided on this page represents TI's knowledge and belief as of the date that it is provided. TI bases its knowledge and belief on information provided by third parties, and makes no representation or warranty as to the accuracy of such information. Efforts are underway to better integrate information from third parties. TI has taken and continues to take reasonable steps to provide representative and accurate information but may not have conducted destructive testing or chemical analysis on incoming materials and chemicals. TI and TI suppliers consider certain information to be proprietary, and thus CAS numbers and other limited information may not be available for release.

In no event shall TI's liability arising out of such information exceed the total purchase price of the TI part(s) at issue in this document sold by TI to Customer on an annual basis.

TAPE AND REEL INFORMATION

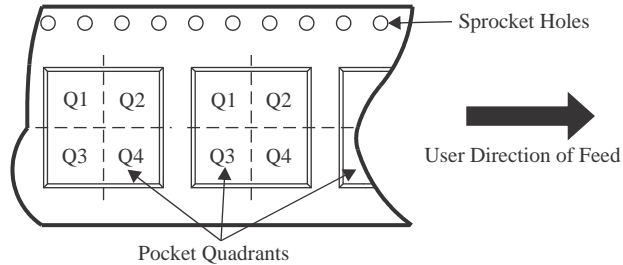
QUADRANT ASSIGNMENTS FOR PIN 1 ORIENTATION IN TAPE

*All dimensions are nominal

Device	Package Type	Package Drawing	Pins	SPQ	Reel Diameter (mm)	Reel Width W1 (mm)	A0 (mm)	B0 (mm)	K0 (mm)	P1 (mm)	W (mm)	Pin1 Quadrant
TPS1HB08AQPWRQ1	HTSSOP	PWP	16	3000	330.0	12.4	6.9	5.6	1.6	8.0	12.0	Q1
TPS1HB08BQPWRQ1	HTSSOP	PWP	16	3000	330.0	12.4	6.9	5.6	1.6	8.0	12.0	Q1
TPS1HB08FQPWRQ1	HTSSOP	PWP	16	3000	330.0	12.4	6.9	5.6	1.6	8.0	12.0	Q1

TAPE AND REEL BOX DIMENSIONS

*All dimensions are nominal

Device	Package Type	Package Drawing	Pins	SPQ	Length (mm)	Width (mm)	Height (mm)
TPS1HB08AQPWRQ1	HTSSOP	PWP	16	3000	350.0	350.0	43.0
TPS1HB08BQPWRQ1	HTSSOP	PWP	16	3000	350.0	350.0	43.0
TPS1HB08FQPWRQ1	HTSSOP	PWP	16	3000	367.0	367.0	38.0

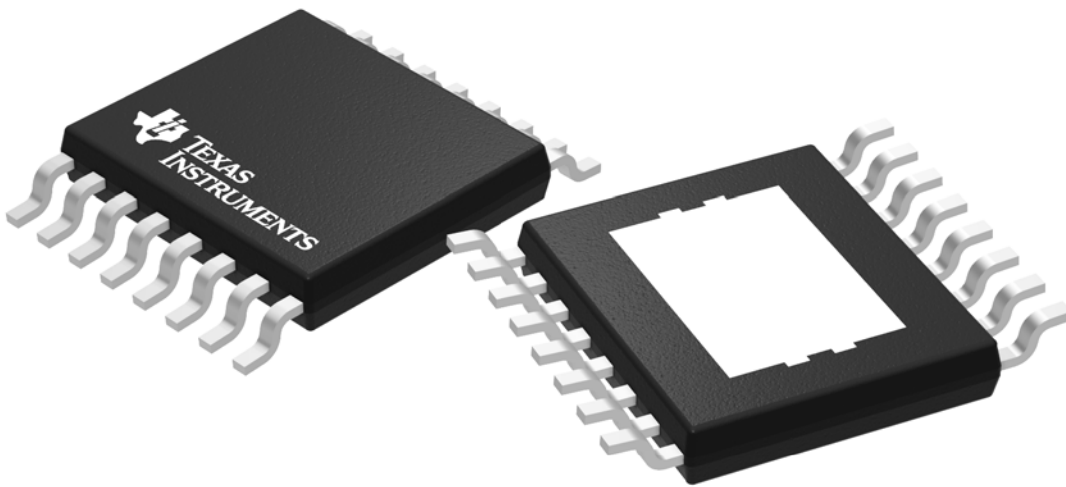

Images above are just a representation of the package family, actual package may vary.
Refer to the product data sheet for package details.

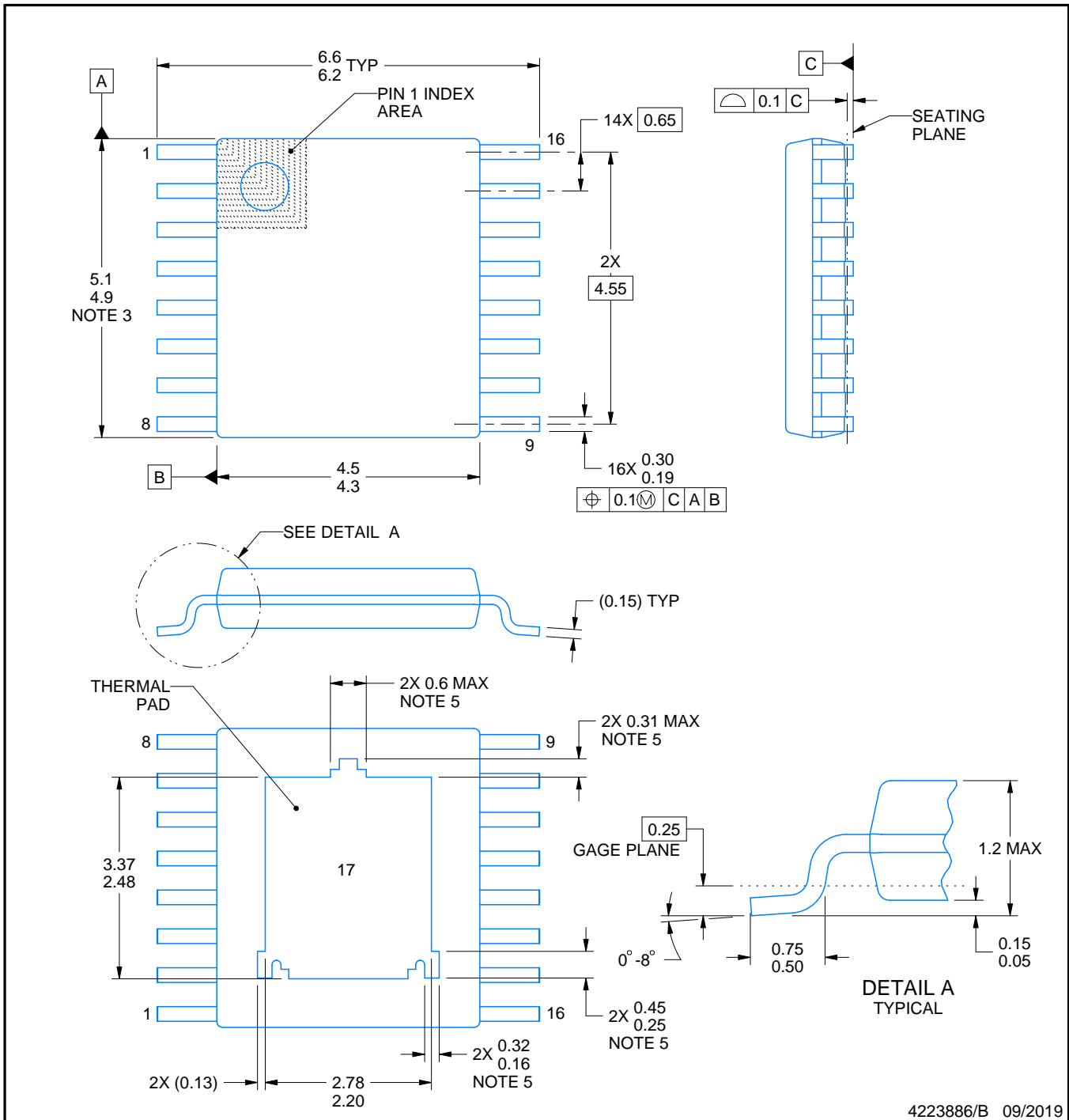
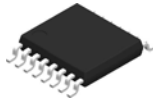

4223886/B 09/2019

NOTES:

PowerPAD is a trademark of Texas Instruments.

1. All linear dimensions are in millimeters. Any dimensions in parenthesis are for reference only. Dimensioning and tolerancing per ASME Y14.5M.
2. This drawing is subject to change without notice.
3. This dimension does not include mold flash, protrusions, or gate burrs. Mold flash, protrusions, or gate burrs shall not exceed 0.15 mm per side.
4. Reference JEDEC registration MO-153.
5. Features may differ or may not be present.

EXAMPLE BOARD LAYOUT

PWP0016M

PowerPAD™ TSSOP - 1.2 mm max height

SMALL OUTLINE PACKAGE

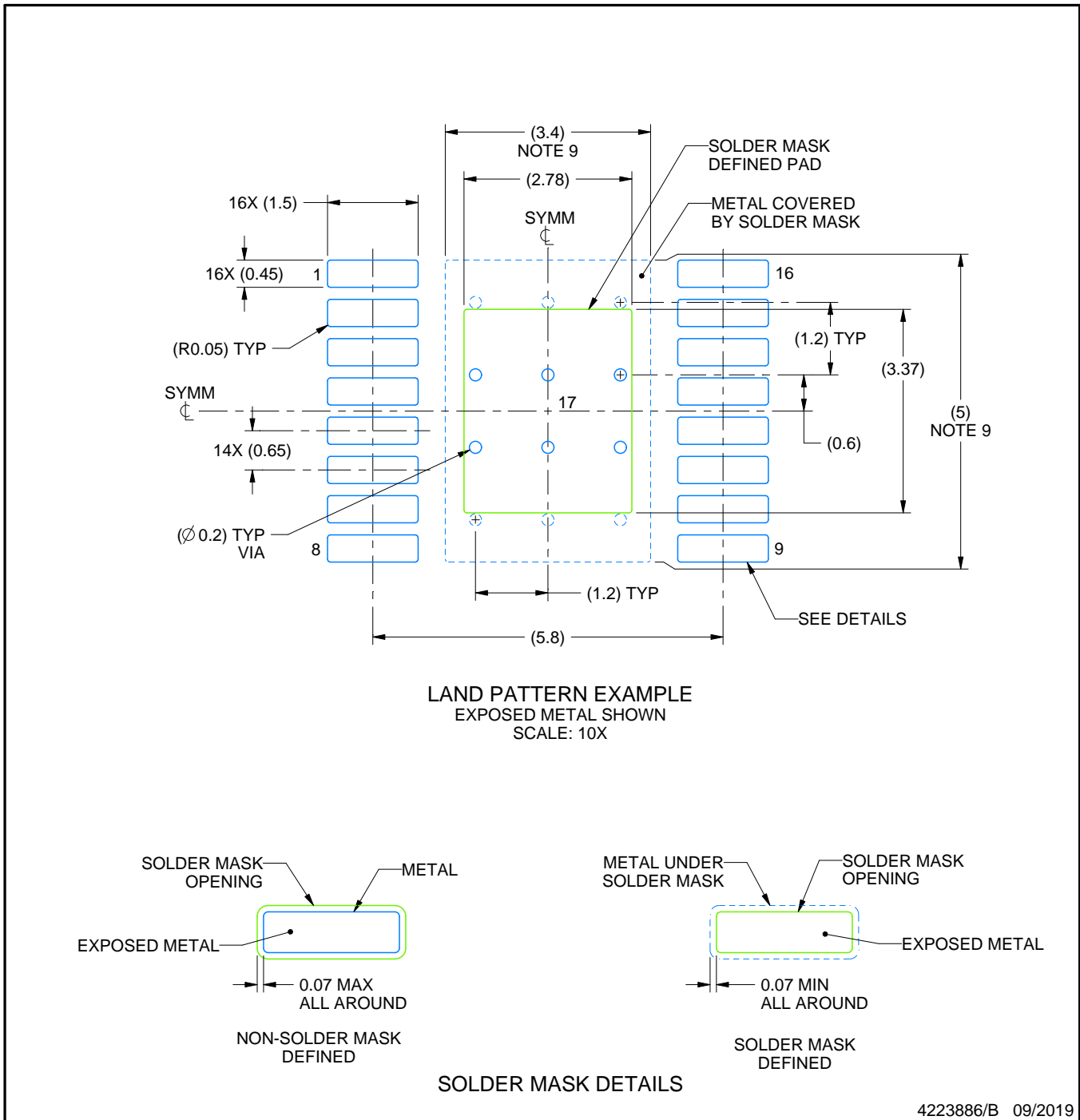

NOTES: (continued)

6. Publication IPC-7351 may have alternate designs.
7. Solder mask tolerances between and around signal pads can vary based on board fabrication site.
8. This package is designed to be soldered to a thermal pad on the board. For more information, see Texas Instruments literature numbers SLMA002 (www.ti.com/lit/slma002) and SLMA004 (www.ti.com/lit/slma004).
9. Size of metal pad may vary due to creepage requirement.
10. Vias are optional depending on application, refer to device data sheet. It is recommended that vias under paste be filled, plugged or tented.

EXAMPLE STENCIL DESIGN

PWP0016M

PowerPAD™ TSSOP - 1.2 mm max height

SMALL OUTLINE PACKAGE

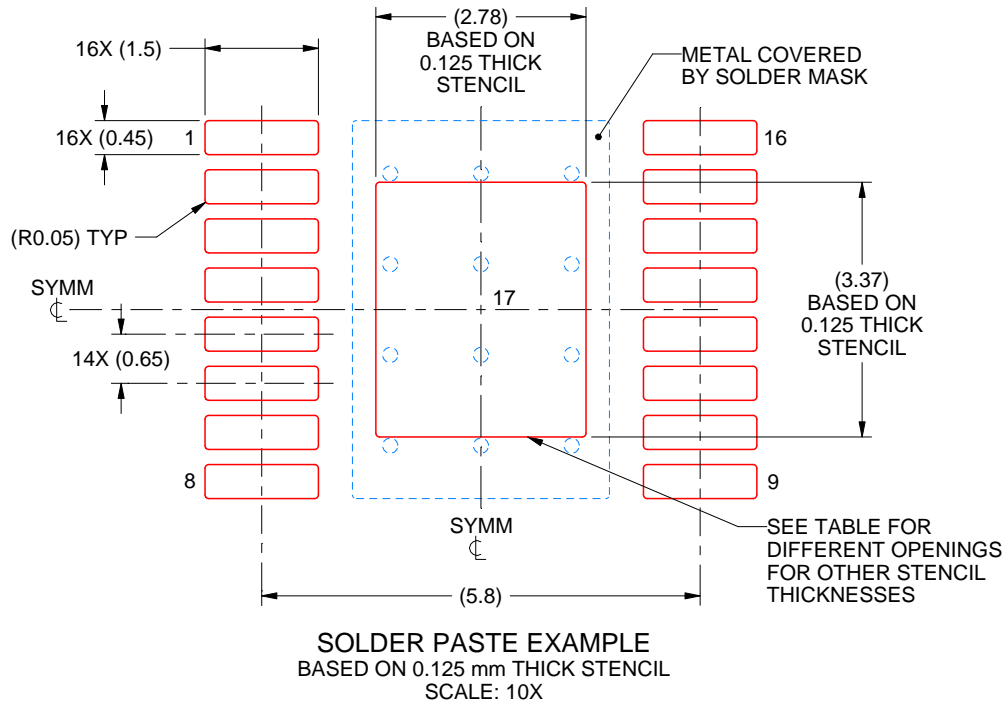

STENCIL THICKNESS	SOLDER STENCIL OPENING
0.1	3.11 X 3.77
0.125	2.78 X 3.37 (SHOWN)
0.15	2.54 X 3.08
0.175	2.35 X 2.85

4223886/B 09/2019

NOTES: (continued)

11. Laser cutting apertures with trapezoidal walls and rounded corners may offer better paste release. IPC-7525 may have alternate design recommendations.
12. Board assembly site may have different recommendations for stencil design.

IMPORTANT NOTICE AND DISCLAIMER

TI PROVIDES TECHNICAL AND RELIABILITY DATA (INCLUDING DATA SHEETS), DESIGN RESOURCES (INCLUDING REFERENCE DESIGNS), APPLICATION OR OTHER DESIGN ADVICE, WEB TOOLS, SAFETY INFORMATION, AND OTHER RESOURCES "AS IS" AND WITH ALL FAULTS, AND DISCLAIMS ALL WARRANTIES, EXPRESS AND IMPLIED, INCLUDING WITHOUT LIMITATION ANY IMPLIED WARRANTIES OF MERCHANTABILITY, FITNESS FOR A PARTICULAR PURPOSE OR NON-INFRINGEMENT OF THIRD PARTY INTELLECTUAL PROPERTY RIGHTS.

These resources are intended for skilled developers designing with TI products. You are solely responsible for (1) selecting the appropriate TI products for your application, (2) designing, validating and testing your application, and (3) ensuring your application meets applicable standards, and any other safety, security, regulatory or other requirements.

These resources are subject to change without notice. TI grants you permission to use these resources only for development of an application that uses the TI products described in the resource. Other reproduction and display of these resources is prohibited. No license is granted to any other TI intellectual property right or to any third party intellectual property right. TI disclaims responsibility for, and you will fully indemnify TI and its representatives against, any claims, damages, costs, losses, and liabilities arising out of your use of these resources.

TI's products are provided subject to [TI's Terms of Sale](#) or other applicable terms available either on [ti.com](https://www.ti.com) or provided in conjunction with such TI products. TI's provision of these resources does not expand or otherwise alter TI's applicable warranties or warranty disclaimers for TI products.

TI objects to and rejects any additional or different terms you may have proposed.

Mailing Address: Texas Instruments, Post Office Box 655303, Dallas, Texas 75265
Copyright © 2023, Texas Instruments Incorporated

Looking for pricing, stock, or lifecycle information?

Click below to explore more details on WIN SOURCE:

 [View TPS1HB08FQPWPRQ1 on WIN SOURCE](#)

 [Texas Instruments](#) Information

Optimize Your Supply Chain with WIN SOURCE Solutions

-  Global Sourcing Solution
-  Obsolete Management
-  Cost Control Management
-  Shortage Management
-  Alternative Solution
-  Excess Inventory Management