



**THE DATASHEET OF
A3P1000-FGG256T**



Automotive ProASIC3 Flash Family FPGAs

Features and Benefits

Extended Temperature AEC-Q100–Qualified Devices

- Grade 2: –40°C to 105°C T_A (115°C T_J)
- Grade 1: –40°C to 125°C T_A (135°C T_J)
- PPAP Documentation

Firm-Error Immune

- Only Automotive FPGAs to Offer Firm-Error Immunity
- Can Be Used without Configuration Upset Risk

High Capacity

- 60 k to 1 M System Gates
- Up to 144 kbits of SRAM
- Up to 300 User I/Os

Reprogrammable Flash Technology

- 130-nm, 7-Layer Metal (6 Copper), Flash-Based CMOS Automotive Process
- Instant On Level 0 Support
- Single-Chip Solution
- Retains Programmed Design when Powered Off

On-Chip User Nonvolatile Memory

- 1 kbit of FlashROM with Synchronous Interface

High Performance

- 350 MHz System Performance
- 3.3 V, 66 MHz 64-Bit PCI

In-System Programming (ISP) and Security

- ISP Using On-Chip 128-Bit Advanced Encryption Standard (AES) Decryption via JTAG (IEEE 1532–compliant)
- FlashLock[®] Designed to Provide High-Level Security for FPGA Contents (anti-tampering)

Low Power

- 1.5 V Core Voltage
- Support for 1.5-V-Only Systems
- Low-Impedance Flash Switches

High-Performance Routing Hierarchy

- Segmented, Hierarchical Routing and Clock Structure
- High-Performance, Low-Skew Global Network
- Architecture Supports Ultra-High Utilization

Advanced I/O

- 700 Mbps DDR, LVDS-Capable I/Os
- 1.5 V, 1.8 V, 2.5 V, and 3.3 V Mixed-Voltage Operation
- Bank-Selectable I/O Voltages—up to 4 Banks per Chip
- Single-Ended I/O Standards: LVTTTL, LVCMOS 3.3 V / 2.5 V / 1.8 V / 1.5 V, 3.3 V PCI / 3.3 V PCI-X, and LVCMOS 2.5 V / 5.0 V Input
- Differential I/O Standards: LVPECL, LVDS, B-LVDS, and M-LVDS (A3P250 and A3P1000)
- I/O Registers on Input, Output, and Enable Paths
- Hot-Swappable and Cold-Sparing I/Os
- Programmable Output Slew Rate and Drive Strength
- Weak Pull-Up/Down
- IEEE 1149.1 (JTAG) Boundary Scan Test
- Pin-Compatible Packages across the Automotive ProASIC[®]3 Family

Clock Conditioning Circuit (CCC) and PLL

- Six CCC Blocks, One with an Integrated PLL
- Configurable Phase Shift, Multiply/Divide, Delay Capabilities, and External Feedback
- Wide Input Frequency Range (1.5 MHz up to 350 MHz)

SRAMs

- Variable-Aspect-Ratio 4,608-Bit RAM Blocks (×1, ×2, ×4, ×9, and ×18 organizations available)

Table 1 • Automotive ProASIC3 Product Family

ProASIC3 Devices	A3P060	A3P125	A3P250	A3P1000
System Gates	60 k	125 k	250 k	1 M
VersaTiles (D-flip-flops)	1,536	3,072	6,144	24,576
RAM kbits (1,024 bits)	18	36	36	144
4,608-Bit Blocks	4	8	8	32
FlashROM Bits	1 k	1 k	1 k	1 k
Secure (AES) ISP	Yes	Yes	Yes	Yes
Integrated PLL in CCCs	1	1	1	1
VersaNet Globals ¹	18	18	18	18
I/O Banks	2	2	4	4
Maximum User I/Os	96	133	157	300
Package Pins				
VQFP	VQ100	VQ100	VQ100	
FBGA	FG144	FG144	FG144, FG256	FG144, FG256, FG484
QFN ²		QNG132	QNG132	

Notes:

1. Six chip-wide (main) globals and three additional global networks in each quadrant are available.
2. QFN packages are available as RoHS compliant only.

I/Os Per Package

ProASIC3 Devices	A3P060	A3P125	A3P250		A3P1000	
Package	I/O Type					
	Single-Ended I/O	Single-Ended I/O	Single-Ended I/O ²	Differential I/O Pairs	Single-Ended I/O ²	Differential I/O Pairs
VQ100	71	71	68	13	–	–
FG144	96	97	97	24	97	25
FG256	–	–	157	38	177	44
FG484	–	–	–	–	300	74
QNG132	–	84	87	19	–	–

Notes:

1. When considering migrating your design to a lower- or higher-density device, refer to the [ProASIC3 FPGA Fabric User's Guide](#) to ensure complying with design and board migration requirements.
2. Each used differential I/O pair reduces the number of available single-ended I/Os by two.
3. FG256 and FG484 are footprint-compatible packages.

Automotive ProASIC3 Device Status

Automotive ProASIC3 Devices	Status
A3P060	Production
A3P125	Production
A3P250	Production
A3P1000	Production

Automotive ProASIC3 Ordering Information

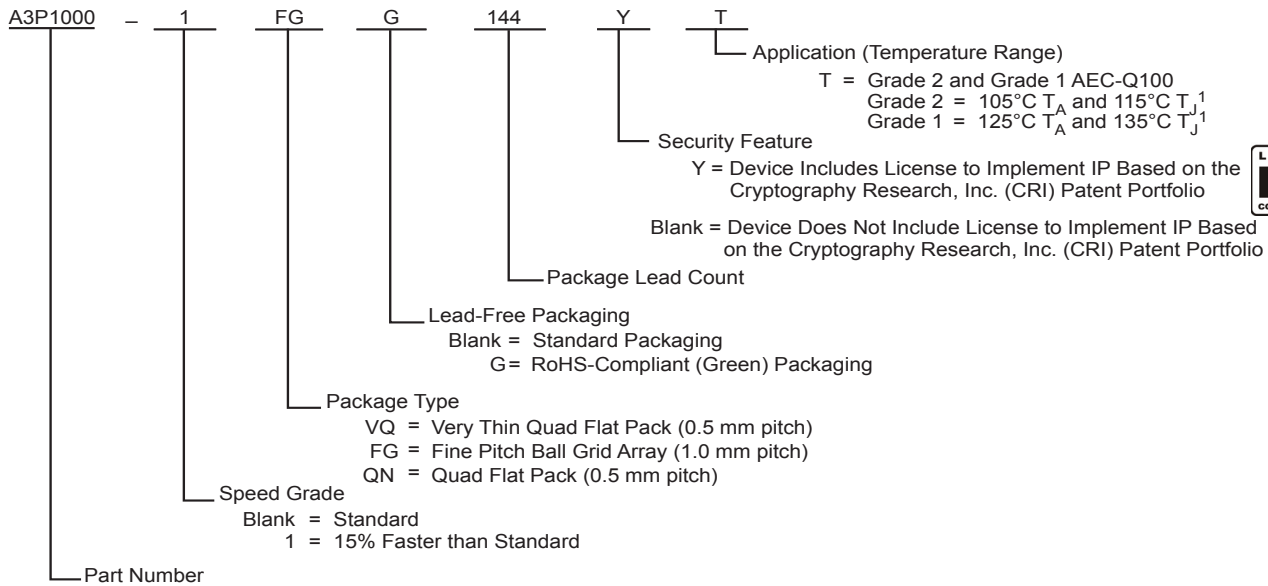

Notes:

1. T_A = Ambient temperature and T_J = Junction temperature.
2. Minimum order quantities apply. Contact your local Microsemi SoC Products Group sales office for details.

Temperature Grade Offerings

Package	A3P060	A3P125	A3P250	A3P1000
VQ100	C, I, T	C, I, T	C, I, T	–
FG144	C, I, T	C, I, T	C, I, T	C, I, T
FG256	–	–	C, I, T	C, I, T
FG484	–	–	–	C, I, T
QNG132	–	C, I, T	C, I, T	–

Notes:

1. C = Commercial temperature range: 0°C to 70°C
2. I = Industrial temperature range: –40°C to 85°C
3. T = Automotive temperature range: Grade 2 and Grade 1 AEC-Q100
 Grade 2 = 105°C T_A and 115°C T_J
 Grade 1 = 125°C T_A and 135°C T_J
4. Specifications for Commercial and Industrial grade devices can be found in the ProASIC3 Flash Family FPGAs datasheet.

Speed Grade and Temperature Grade Matrix

Temperature Grade	Std.	–1
T (Grade 1 and Grade 2), Commercial, Industrial	3	3

Notes:

1. T = Automotive temperature range: Grade 2 and Grade 1 AEC-Q100
 Grade 2 = 105°C T_A and 115°C T_J
 Grade 1 = 125°C T_A and 135°C T_J
2. Specifications for Commercial and Industrial grade devices can be found in the ProASIC3 Flash Family FPGAs datasheet.

Contact your local Microsemi SoC Products Group representative for device availability:

<http://www.microsemi.com/soc/contact/default.aspx>.

Table of Contents

Automotive ProASIC3 Device Family Overview

General Description	1-1
---------------------------	-----

Automotive ProASIC3 DC and Switching Characteristics

General Specifications	2-1
Calculating Power Dissipation	2-6
User I/O Characteristics	2-12
VersaTile Characteristics	2-69
Global Resource Characteristics	2-75
Clock Conditioning Circuits	2-80
Embedded SRAM and FIFO Characteristics	2-82
Embedded FlashROM Characteristics	2-96
JTAG 1532 Characteristics	2-97

Pin Descriptions and Packaging

Supply Pins	3-1
User Pins	3-2
JTAG Pins	3-3
Special Function Pins	3-4
Packaging	3-4
Related Documents	3-4

Package Pin Assignments

VQ100	4-1
QN132	4-5
FG144	4-10
FG256	4-19
FG484	4-26

Datasheet Information

List of Changes	5-1
Datasheet Categories	5-4
Safety Critical, Life Support, and High-Reliability Applications Policy	5-4

1 – Automotive ProASIC3 Device Family Overview

General Description

Automotive ProASIC3 nonvolatile flash technology gives automotive system designers the advantage of a secure, low-power, single-chip solution that is Instant On. Automotive ProASIC3 is reprogrammable and offers time-to-market benefits at an ASIC-level unit cost. These features enable designers to create high-density systems using existing ASIC or FPGA design flows and tools.

Automotive ProASIC3 devices offer 1 kbit of on-chip, reprogrammable, nonvolatile FlashROM storage as well as clock conditioning circuitry based on an integrated phase-locked loop (PLL). Automotive ProASIC3 devices have up to 1 million system gates, supported with up to 144 kbits of SRAM and up to 300 user I/Os.

Automotive ProASIC3 devices are the only firm-error-immune automotive grade FPGAs. Firm-error immunity makes them ideally suited for demanding applications in powertrain, safety, and telematics-based subsystems, where firm-error failure is not an option.

Firm errors in SRAM-based FPGAs can result in high defect levels in field-deployed systems. These unavoidable defects must be considered separately from standard defects and failure mechanisms when looking at overall system quality and reliability.

Flash Advantages

Reduced Cost of Ownership

Advantages to the designer extend beyond low unit cost, performance, and ease of use. Unlike SRAM-based FPGAs, flash-based Automotive ProASIC3 devices allow all functionality to be Instant On; no external boot PROM is required. On-board security mechanisms prevent access to all the programming information and enable secure remote updates of the FPGA logic. Flash-based FPGAs are LAPU Class 0 devices, offering the lowest available power in a single-chip device and providing firm-error immunity. The Automotive ProASIC3 family device architecture mitigates the need for ASIC migration at high user volumes. This makes the Automotive ProASIC3 family a cost-effective ASIC replacement solution, especially for automotive applications.

Security

Nonvolatile, flash-based Automotive ProASIC3 devices do not require a boot PROM, so there is no vulnerable external bitstream that can be easily copied. Automotive ProASIC3 devices incorporate FlashLock, which provides a unique combination of reprogrammability and design security without external overhead, advantages that only an FPGA with nonvolatile flash programming can offer.

Automotive ProASIC3 devices utilize a 128-bit flash-based lock and a separate AES key to provide the highest level of protection in the FPGA industry for intellectual property and configuration data. In addition, all FlashROM data in Automotive ProASIC3 devices can be encrypted prior to loading, using the industry-leading AES-128 (FIPS192) bit block cipher encryption standard. The AES was adopted by the National Institute of Standards and Technology (NIST) in 2000 and replaces the 1977 DES standard. Automotive ProASIC3 devices have a built-in AES decryption engine and a flash-based AES key that make them the most comprehensive programmable logic device security solution available today. Automotive ProASIC3 devices with AES-based security provide a high level of protection for secure, remote field updates over public networks such as the Internet, and are designed to ensure that valuable IP remains out of the hands of system overbuilders, system cloners, and IP thieves. Additionally, security features of Automotive ProASIC3 devices provide anti-tampering protection.

Security, built into the FPGA fabric, is an inherent component of the Automotive ProASIC3 family. The flash cells are located beneath seven metal layers, and many device design and layout techniques have been used to make invasive attacks extremely difficult. The Automotive ProASIC3 family, with FlashLock and AES security, is unique in being highly resistant to both invasive and noninvasive attacks. Your valuable IP is protected with industry-standard security, making remote ISP possible. An Automotive ProASIC3 device provides the best available security for programmable logic designs.

Single Chip

Flash-based FPGAs store their configuration information in on-chip flash cells. Once programmed, the configuration data is an inherent part of the FPGA structure, and no external configuration data needs to be loaded at system power-up (unlike SRAM-based FPGAs). Therefore, flash-based Automotive ProASIC3 FPGAs do not require system configuration components such as EEPROMs or microcontrollers to load device configuration data. This reduces bill-of-materials costs and PCB area, and increases security and system reliability.

Instant On

The Microsemi flash-based Automotive ProASIC3 devices support Level 0 of the Instant On classification standard. This feature helps in system component initialization, execution of critical tasks before the processor wakes up, setup and configuration of memory blocks, clock generation, and bus activity management. The Instant On feature of flash-based Automotive ProASIC3 devices greatly simplifies total system design and reduces total system cost, often eliminating the need for CPLDs and external clock generation PLLs. In addition, glitches and brownouts in system power will not corrupt the Automotive ProASIC3 device's flash configuration, and unlike SRAM-based FPGAs, the device will not have to be reloaded when system power is restored. This enables the reduction or complete removal of the configuration PROM, expensive voltage monitor, brownout detection, and clock generator devices from the PCB design. Flash-based Automotive ProASIC3 devices simplify total system design and reduce cost and design risk while increasing system reliability and improving system initialization time.

Firm-Error Immunity

Firm errors occur most commonly when high-energy neutrons, generated in the upper atmosphere, strike a configuration cell of an SRAM FPGA. The energy of the collision can change the state of the configuration cell and thus change the logic, routing, or I/O behavior in an unpredictable way. These errors are impossible to prevent in SRAM FPGAs. The consequence of this type of error can be a complete system failure. Firm errors do not exist in the configuration memory of Automotive ProASIC3 flash-based FPGAs. Once it is programmed, the flash cell configuration element of Automotive ProASIC3 FPGAs cannot be altered by high-energy neutrons and is therefore immune to them. Recoverable (or soft) errors occur in the user data SRAM of all FPGA devices. These can easily be mitigated by using error detection and correction (EDAC) circuitry built into the FPGA fabric.

Low Power

Flash-based Automotive ProASIC3 devices exhibit very low power characteristics, similar to those of an ASIC, making them an ideal choice for power-sensitive applications. Automotive ProASIC3 devices have only a very limited power-on current surge and no high-current transition period, both of which occur on many FPGAs.

Automotive ProASIC3 devices also have low dynamic power consumption to further maximize power savings.

Advanced Flash Technology

The Automotive ProASIC3 family offers many benefits, including nonvolatility and reprogrammability, through an advanced flash-based, 130-nm LVCMOS process with seven layers of metal. Standard CMOS design techniques are used to implement logic and control functions. The combination of fine granularity, enhanced flexible routing resources, and abundant flash switches allows for very high logic utilization without compromising device routability or performance. Logic functions within the device are interconnected through a four-level routing hierarchy.

Advanced Architecture

The proprietary Automotive ProASIC3 architecture provides granularity comparable to standard-cell ASICs. The Automotive ProASIC3 device consists of five distinct and programmable architectural features (Figure 1-1 and Figure 1-2 on page 1-4):

- FPGA VersaTiles
- Dedicated FlashROM
- Dedicated SRAM memory
- Extensive CCCs and PLLs
- Advanced I/O structure

The FPGA core consists of a sea of VersaTiles. Each VersaTile can be configured as a three-input logic function, a D-flip-flop (with or without enable), or a latch by programming the appropriate flash switch interconnections. The versatility of the Automotive ProASIC3 core tile as either a three-input lookup table (LUT) equivalent or a D-flip-flop/latch with enable allows for efficient use of the FPGA fabric. The VersaTile capability is unique to the Microsemi ProASIC family of third-generation-architecture flash FPGAs. VersaTiles are connected with any of the four levels of routing hierarchy. Flash switches are distributed throughout the device to provide nonvolatile, reconfigurable interconnect programming. Maximum core utilization is possible for virtually any design.

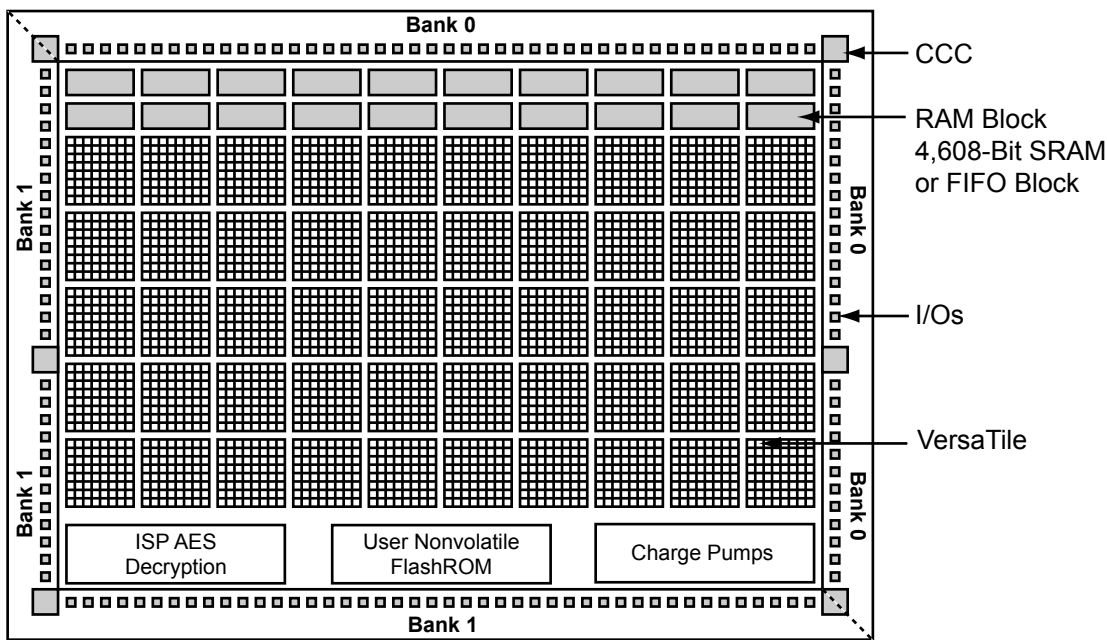

Figure 1-1 • Automotive ProASIC3 Device Architecture Overview with Two I/O Banks (A3P060 and A3P125)

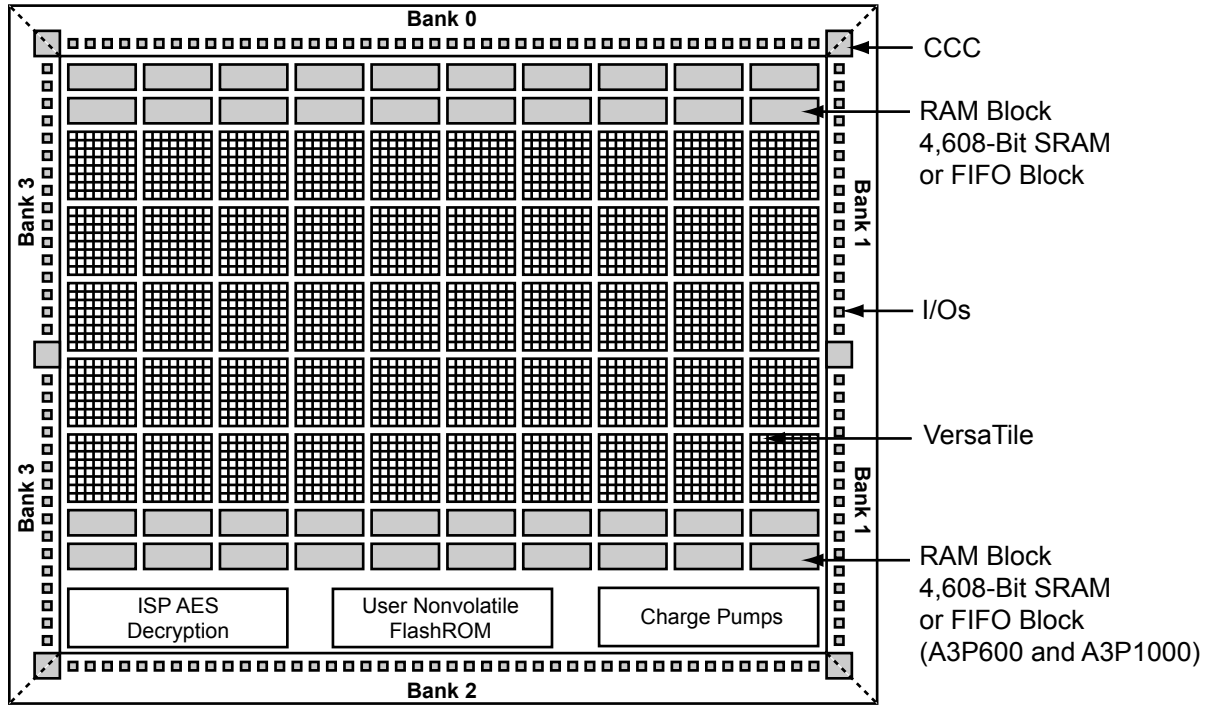

Figure 1-2 • Automotive ProASIC3 Device Architecture Overview with Four I/O Banks (A3P600 and A3P1000)

VersaTiles

The Automotive ProASIC3 core consists of VersaTiles, which have been enhanced beyond the ProASIC^{PLUS}® core tiles. The Automotive ProASIC3 VersaTile supports the following:

- All 3-input logic functions—LUT-3 equivalent
- Latch with clear or set
- D-flip-flop with clear or set
- Enable D-flip-flop with clear or set

Refer to Figure 1-3 for VersaTile configurations.

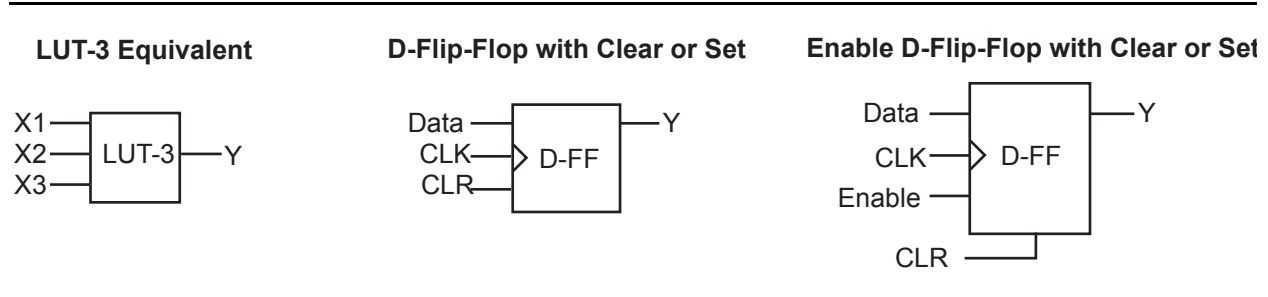

Figure 1-3 • VersaTile Configurations

User Nonvolatile FlashROM

Automotive ProASIC3 devices have 1 kbit of on-chip, user-accessible, nonvolatile FlashROM. The FlashROM can be used in diverse system applications:

- Unique protocol addressing (wireless or fixed)
- System calibration settings
- Device serialization and/or inventory control
- Subscription-based business models (for example, infotainment systems)
- Secure key storage for secure communications algorithms
- Asset management/tracking
- Date stamping
- Version management

The FlashROM is written using the standard Automotive ProASIC3 IEEE 1532 JTAG programming interface.

The FlashROM can be programmed via the JTAG programming interface, and its contents can be read back either through the JTAG programming interface or via direct FPGA core addressing. Note that the FlashROM can only be programmed from the JTAG interface and cannot be programmed from the internal logic array.

The FlashROM is programmed as 8 banks of 128 bits; however, reading is performed on a byte-by-byte basis using a synchronous interface. A 7-bit address from the FPGA core defines which of the 8 banks and which of the 16 bytes within that bank are being read. The three most significant bits (MSBs) of the FlashROM address determine the bank, and the four least significant bits (LSBs) of the FlashROM address define the byte.

Automotive ProASIC3 development software solutions, Libero[®] System-on-Chip (SoC) and Designer, have extensive support for the FlashROM. One such feature is auto-generation of sequential programming files for applications requiring a unique serial number in each part. Another feature allows the inclusion of static data for system version control. Data for the FlashROM can be generated quickly and easily using Libero SoC and Designer software tools. Comprehensive programming file support is also included to allow for easy programming of large numbers of parts with differing FlashROM contents.

SRAM

Automotive ProASIC3 devices have embedded SRAM blocks along their north and south sides. Each variable-aspect-ratio SRAM block is 4,608 bits in size. Available memory configurations are 256×18, 512×9, 1k×4, 2k×2, and 4k×1 bits. The individual blocks have independent read and write ports that can be configured with different bit widths on each port. For example, data can be sent through a 4-bit port and read as a single bitstream. The embedded SRAM blocks can be initialized via the device JTAG port (ROM emulation mode) using the UJTAG macro.

PLL and CCC

Automotive ProASIC3 devices provide designers with very flexible clock conditioning circuit (CCC) capabilities. Each member of the Automotive ProASIC3 family contains six CCCs. One CCC (center west side) has a PLL.

The six CCC blocks are located at the four corners and the centers of the east and west sides. One CCC (center west side) has a PLL.

All six CCC blocks are usable; the four corner CCCs and the east CCC allow simple clock delay operations as well as clock spine access.

The inputs of the six CCC blocks are accessible from the FPGA core or from one of several inputs located near the CCC that have dedicated connections to the CCC block.

The CCC block has these key features:

- Wide input frequency range (f_{IN_CCC}) = 1.5 MHz to 350 MHz
- Output frequency range (f_{OUT_CCC}) = 0.75 MHz to 350 MHz
- Clock delay adjustment via programmable and fixed delays from –7.56 ns to +11.12 ns
- 2 programmable delay types for clock skew minimization
- Clock frequency synthesis (for PLL only)

Additional CCC specifications:

- Internal phase shift = 0°, 90°, 180°, and 270°. Output phase shift depends on the output divider configuration (for PLL only).
- Output duty cycle = 50% ± 1.5% or better (for PLL only)
- Low output jitter: worst case < 2.5% × clock period peak-to-peak period jitter when single global network used (for PLL only)
- Maximum acquisition time is 300 μs (for PLL only)
- Low power consumption of 5 mW
- Exceptional tolerance to input period jitter— allowable input jitter is up to 1.5 ns (for PLL only)
- Four precise phases; maximum misalignment between adjacent phases of 40 ps × 350 MHz / f_{OUT_CCC} (for PLL only)

Global Clocking

Automotive ProASIC3 devices have extensive support for multiple clocking domains. In addition to the CCC and PLL support described above, there is a comprehensive global clock distribution network.

Each VersaTile input and output port has access to nine VersaNets: six chip (main) and three quadrant global networks. The VersaNets can be driven by the CCC or directly accessed from the core via multiplexers (MUXes). The VersaNets can be used to distribute low-skew clock signals or for rapid distribution of high-fanout nets.

I/Os with Advanced I/O Standards

The Automotive ProASIC3 family of FPGAs features a flexible I/O structure, supporting a range of voltages (1.5 V, 1.8 V, 2.5 V, and 3.3 V). Automotive ProASIC3 FPGAs support many different I/O standards—single-ended and differential.

The I/Os are organized into banks, with two or four banks per device. The configuration of these banks determines the I/O standards supported.

Each I/O module contains several input, output, and enable registers. These registers allow the implementation of the following:

- Single-Data-Rate applications
- Double-Data-Rate applications—DDR LVDS, B-LVDS, and M-LVDS I/Os for point-to-point communications

Automotive ProASIC3 banks for the A3P250 and A3P1000 devices support LVPECL, LVDS, B-LVDS, and M-LVDS. B-LVDS and M-LVDS can support up to 20 loads.

Specifying I/O States During Programming

You can modify the I/O states during programming in FlashPro. In FlashPro, this feature is supported for PDB files generated from Designer v8.5 or greater. See the [FlashPro User's Guide](#) for more information.

Note: PDB files generated from Designer v8.1 to Designer v8.4 (including all service packs) have limited display of Pin Numbers only.

1. Load a PDB from the FlashPro GUI. You must have a PDB loaded to modify the I/O states during programming.
2. From the FlashPro GUI, click PDB Configuration. A FlashPoint – Programming File Generator window appears.
3. Click the Specify I/O States During Programming button to display the Specify I/O States During Programming dialog box.
4. Sort the pins as desired by clicking any of the column headers to sort the entries by that header. Select the I/Os you wish to modify ([Figure 1-4 on page 1-7](#)).

5. Set the I/O Output State. You can set Basic I/O settings if you want to use the default I/O settings for your pins, or use Custom I/O settings to customize the settings for each pin. Basic I/O state settings:

1 – I/O is set to drive out logic High

0 – I/O is set to drive out logic Low

Last Known State – I/O is set to the last value that was driven out prior to entering the programming mode, and then held at that value during programming

Z -Tristate: I/O is tristated

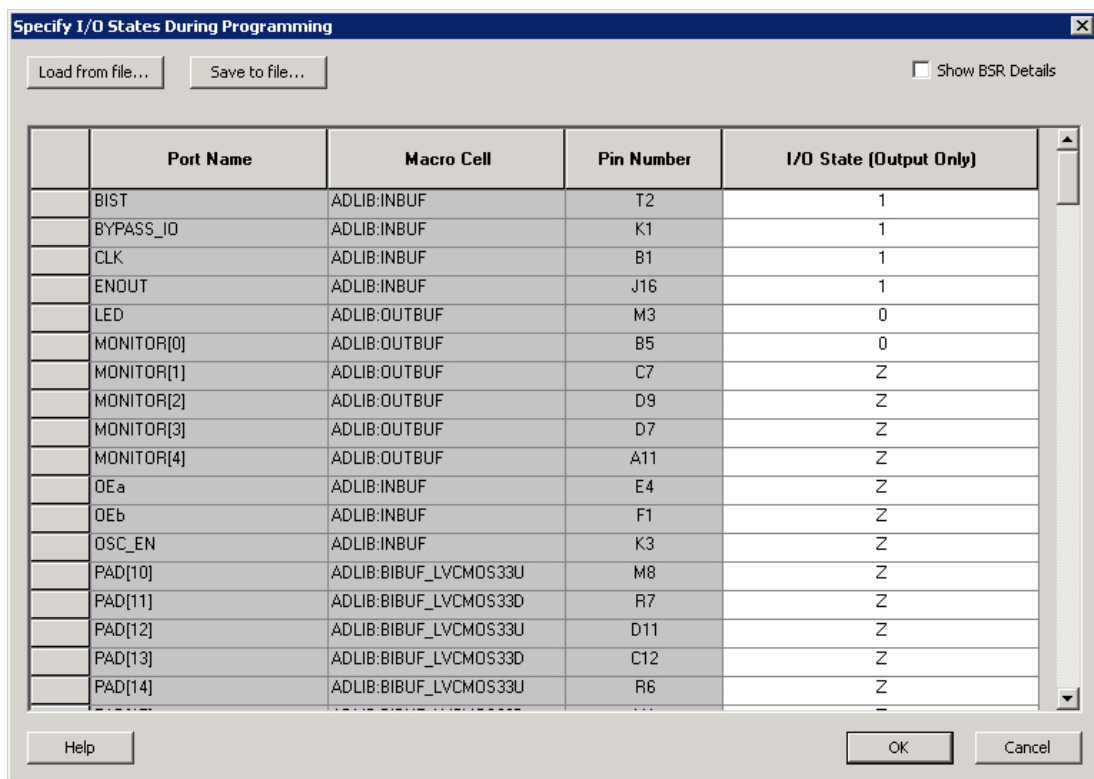

Figure 1-4 • I/O States During Programming Window

6. Click **OK** to return to the FlashPoint – Programming File Generator window.

Note: I/O States During programming are saved to the ADB and resulting programming files after completing programming file generation.

2 – Automotive ProASIC3 DC and Switching Characteristics

General Specifications

Operating Conditions

Stresses beyond those listed in [Table 2-1](#) may cause permanent damage to the device.

Exposure to absolute maximum rating conditions for extended periods may affect device reliability. Absolute Maximums are stress ratings only; functional operation of the device at these or any other conditions beyond those listed under the Recommended Operating Conditions specified in [Table 2-2](#) on [page 2-2](#) is not implied.

Table 2-1 • Absolute Maximum Ratings

Symbol	Parameter	Limits	Units
VCC	DC core supply voltage	–0.3 to 1.65	V
VJTAG	JTAG DC voltage	–0.3 to 3.75	V
VPUMP	Programming voltage	–0.3 to 3.75	V
VCCPLL	Analog power supply (PLL)	–0.3 to 1.65	V
VCCI	DC I/O output buffer supply voltage	–0.3 to 3.75	V
VMV	DC I/O input buffer supply voltage	–0.3 to 3.75	V
VI	I/O input voltage	–0.3 V to 3.6 V (when I/O hot insertion mode is enabled) –0.3 V to (V _{CCI} + 1 V) or 3.6 V, whichever voltage is lower (when I/O hot-insertion mode is disabled)	V
T _{STG} ²	Storage temperature	–65 to +150	°C
T _J ²	Junction temperature	+150	°C

Notes:

1. The device should be operated within the limits specified by the datasheet. During transitions, the input signal may undershoot or overshoot according to the limits shown in [Table 2-3](#) on [page 2-3](#).
2. For flash programming and retention maximum limits, refer to [Figure 2-1](#) on [page 2-2](#). For recommended operating limits, refer to [Table 2-2](#) on [page 2-2](#).

Table 2-2 • Recommended Operating Conditions

Symbol	Parameter	Automotive Grade 1	Automotive Grade 2	Units	
T _J	Junction temperature	-40 to +135	-40 to +115	°C	
VCC	1.5 V DC core supply voltage	1.425 to 1.575	1.425 to 1.575	V	
VJTAG	JTAG DC voltage	1.4 to 3.6	1.4 to 3.6	V	
VPUMP	Programming voltage	Programming Mode ³	3.15 to 3.45	3.15 to 3.45	V
		Operation ⁴	0 to 3.6	0 to 3.6	V
VCCPLL	Analog power supply (PLL)	1.425 to 1.575	1.425 to 1.575	V	
VCCI and VMV	1.5 V DC supply voltage	1.425 to 1.575	1.425 to 1.575	V	
	1.8 V DC supply voltage	1.7 to 1.9	1.7 to 1.9	V	
	2.5 V DC supply voltage	2.3 to 2.7	2.3 to 2.7	V	
	3.3 V DC supply voltage	3.0 to 3.6	3.0 to 3.6	V	
	LVDS/B-LVDS/M-LVDS differential I/O	2.375 to 2.625	2.375 to 2.625	V	
	LVPECL differential I/O	3.0 to 3.6	3.0 to 3.6	V	

Notes:

- The ranges given here are for power supplies only. The recommended input voltage ranges specific to each I/O standard are given in [Table 2-14 on page 2-16](#). VMV and VCCI should be at the same voltage within a given I/O bank.
- All parameters representing voltages are measured with respect to GND unless otherwise specified.
- The programming temperature range supported is T_{ambient} = 0°C to 85°C.
- V_{PUMP} can be left floating during operation (not programming mode).

T _J (°C)	HTR Lifetime (yrs)
70	102.7
85	43.8
100	20.0
105	15.6
110	12.3
115	9.7
120	7.7
125	6.2
130	5.0
135	4.0
140	3.3
145	2.7
150	2.2

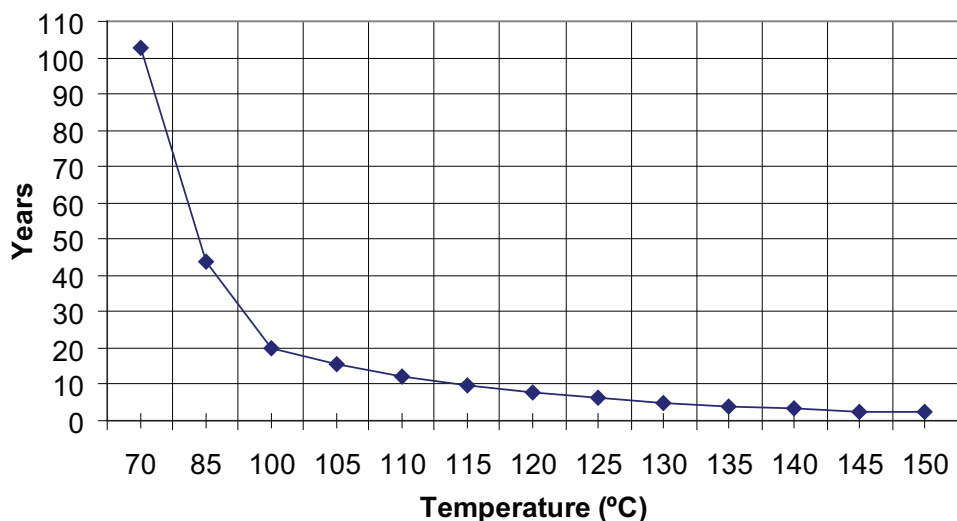

Note: HTR time is the period during which you would not expect a verify failure due to flash cell leakage.

Figure 2-1 • High-Temperature Data Retention (HTR)

Table 2-3 • Overshoot and Undershoot Limits (as measured on quiet I/Os)

VCCI and VMV	Average VCCI–GND Overshoot or Undershoot Duration as a Percentage of Clock Cycle	Maximum Overshoot/Undershoot (115°C)	Maximum Overshoot/Undershoot (135°C)
2.7 V or less	10%	0.81 V	0.72 V
	5%	0.90 V	0.82 V
3 V	10%	0.80 V	0.72 V
	5%	0.90 V	0.81 V
3.3 V	10%	0.79 V	0.69 V
	5%	0.88 V	0.79 V
3.6 V	10%	N/A	N/A
	5%	N/A	N/A

Notes:

1. The duration is allowed at one out of six clock cycles (estimated SSO density over cycles). If the overshoot/undershoot occurs at one out of two cycles, the maximum overshoot/undershoot has to be reduced by 0.15 V.
2. This table refers only to overshoot/undershoot limits for simultaneously switching I/Os and does not provide PCI overshoot/undershoot limits.

I/O Power-Up and Supply Voltage Thresholds for Power-On Reset (Commercial and Industrial)

Sophisticated power-up management circuitry is designed into every ProASIC[®]3 device. These circuits ensure easy transition from the powered-off state to the powered-up state of the device. The many different supplies can power up in any sequence with minimized current spikes or surges. In addition, the I/O will be in a known state through the power-up sequence. The basic principle is shown in [Figure 2-2 on page 2-4](#).

There are five regions to consider during power-up.

ProASIC3 I/Os are activated only if ALL of the following three conditions are met:

1. VCC and VCCI are above the minimum specified trip points ([Figure 2-2 on page 2-4](#)).
2. VCCI > VCC – 0.75 V (typical)
3. Chip is in the operating mode.

VCCI Trip Point:

Ramping up: 0.6 V < trip_point_up < 1.2 V

Ramping down: 0.5 V < trip_point_down < 1.1 V

VCC Trip Point:

Ramping up: 0.6 V < trip_point_up < 1.1 V

Ramping down: 0.5 V < trip_point_down < 1 V

VCC and VCCI ramp-up trip points are about 100 mV higher than ramp-down trip points. This specifically built-in hysteresis prevents undesirable power-up oscillations and current surges. Note the following:

- During programming, I/Os become tristated and weakly pulled up to V_{CCL}.
- JTAG supply, PLL power supplies, and charge pump V_{PUMP} supply have no influence on I/O behavior.

Internal Power-Up Activation Sequence

1. Core
2. Input buffers
3. Output buffers, after 200 ns delay from input buffer activation

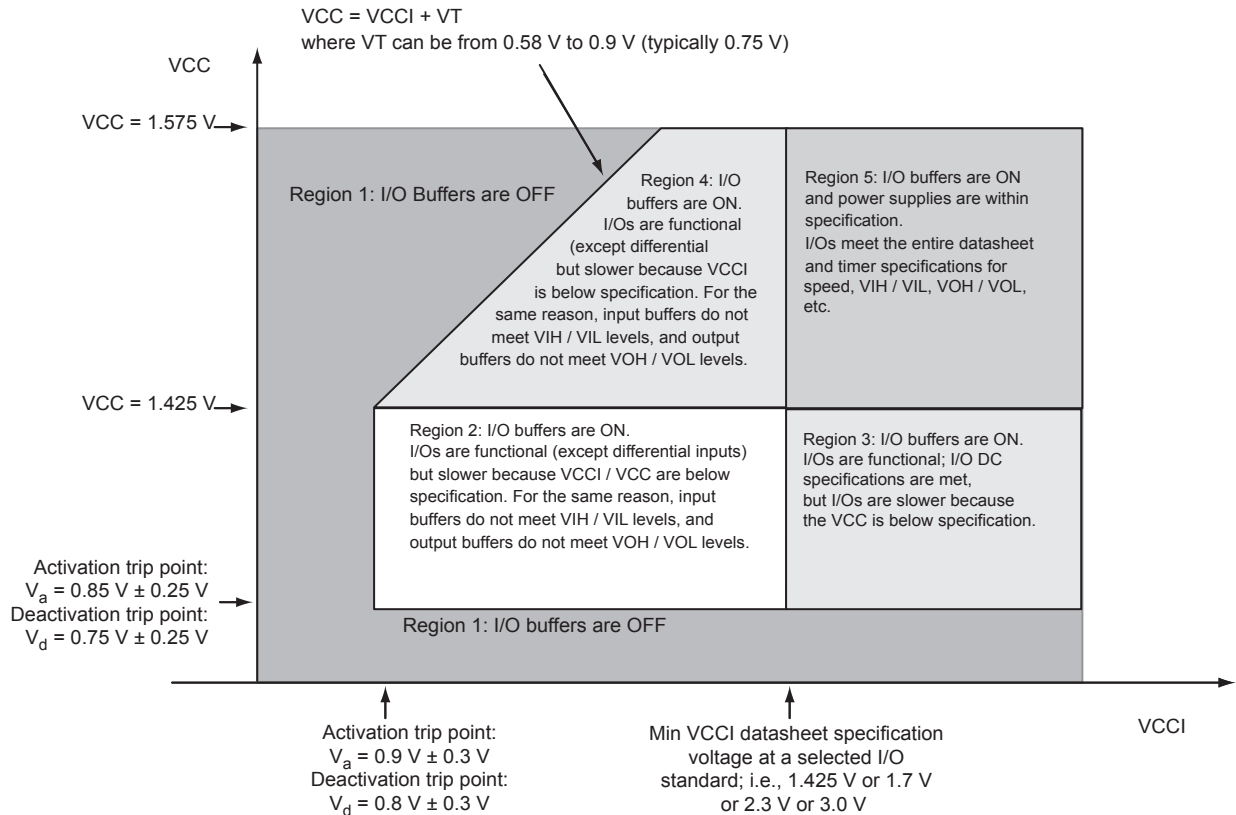
Figure 2-2 • I/O State as a Function of VCCI and VCC Voltage Levels

Thermal Characteristics

Introduction

The temperature variable in Designer software refers to the junction temperature, not the ambient temperature. This is an important distinction because dynamic and static power consumption cause the chip junction to be higher than the ambient temperature.

EQ 1 can be used to calculate junction temperature.

$$T_J = \text{Junction Temperature} = \Delta T + T_A$$

EQ 1

where:

T_A = Ambient Temperature

ΔT = Temperature gradient between junction (silicon) and ambient $\Delta T = \theta_{ja} * P$

θ_{ja} = Junction-to-ambient of the package. θ_{ja} numbers are located in Table 2-4 on page 2-5.

P = Power dissipation

Package Thermal Characteristics

The device junction-to-case thermal resistivity is θ_{jc} and the junction-to-ambient air thermal resistivity is θ_{ja} . The thermal characteristics for θ_{ja} are shown for two air flow rates. The absolute maximum junction temperature is 110°C. EQ 2 shows a sample calculation of the absolute maximum power dissipation allowed for a 484-pin FBGA package at commercial temperature and in still air.

$$\text{Maximum Power Allowed} = \frac{\text{Max. junction temp. (}^\circ\text{C)} - \text{Max. ambient temp. (}^\circ\text{C)}}{\theta_{ja}(\text{}^\circ\text{C/W)}} = \frac{110^\circ\text{C} - 70^\circ\text{C}}{20.5^\circ\text{C/W}} = 1.951 \text{ W}$$

EQ 2

Table 2-4 • Package Thermal Resistivities

Package Type	Device	Pin Count	θ_{jc}	θ_{ja}			Units
				Still Air	200 ft./min.	500 ft./min.	
Very Thin Quad Flat Pack (VQFP)	All devices	100	10.0	35.3	29.4	27.1	°C/W
Fine Pitch Ball Grid Array (FBGA)	See note*	144	3.8	26.9	22.9	21.5	°C/W
	See note*	256	3.8	26.6	22.8	21.5	°C/W
	See note*	484	3.2	20.5	17.0	15.9	°C/W
	A3P1000	144	6.3	31.6	26.2	24.2	°C/W
	A3P1000	256	6.6	28.1	24.4	22.7	°C/W
	A3P1000	484	8.0	23.3	19.0	16.7	°C/W

Note: *This information applies to all ProASIC3 devices except the A3P1000. Detailed device/package thermal information will be available in future revisions of the datasheet.

Temperature and Voltage Derating Factors

Table 2-5 • Temperature and Voltage Derating Factors for Timing Delays (normalized to $T_J = 115^\circ\text{C}$, $V_{CC} = 1.425 \text{ V}$)

Array Voltage V_{CC} (V)	-40°C	0°C	25°C	70°C	85°C	115°C	125°C	135°C
1.425	0.83	0.88	0.90	0.95	0.97	1.00	1.01	1.02
1.5	0.79	0.83	0.85	0.90	0.92	0.95	0.96	0.97
1.575	0.76	0.80	0.82	0.87	0.88	0.91	0.93	0.94

Calculating Power Dissipation

Quiescent Supply Current

Table 2-6 • Quiescent Supply Current Characteristics

	A3P060	A3P125	A3P250	A3P1000
Typical (25°C)	2 mA	2 mA	3 mA	8 mA
Maximum (Automotive Grade 1) – 135°C	53 mA	53 mA	106 mA	265 mA
Maximum (Automotive Grade 2) – 115°C	26 mA	26 mA	53 mA	131 mA

Note: I_{DD} includes V_{CC} , V_{PUMP} , V_{CCI} , and V_{MV} currents. Values do not include I/O static contribution, which is shown in Table 2-7 and Table 2-10 on page 2-8.

Power per I/O Pin

**Table 2-7 • Summary of I/O Input Buffer Power (per pin) – Default I/O Software Settings ¹
Applicable to Advanced I/O Banks**

	VMV (V)	Static Power P_{DC2} (mW) ¹	Dynamic Power P_{AC9} (μ W/MHz) ²
Single-Ended			
3.3 V LVTTTL / 3.3 V LVCMOS	3.3	–	16.69
2.5 V LVCMOS	2.5	–	5.12
1.8 V LVCMOS	1.8	–	2.13
1.5 V LVCMOS (JESD8-11)	1.5	–	1.45
3.3 V PCI	3.3	–	18.11
3.3 V PCI-X	3.3	–	18.11
Differential			
LVDS	2.5	2.26	1.20
LVPECL	3.3	5.72	1.87

Notes:

- P_{DC2} is the static power (where applicable) measured on VMV.
- P_{AC9} is the total dynamic power measured on V_{CC} and VMV.

Table 2-8 • Summary of I/O Input Buffer Power (per pin) – Default I/O Software Settings¹
 Applicable to Standard Plus I/O Banks

	VMV (V)	Static Power PDC2 (mW) ¹	Dynamic Power PAC9 (μW/MHz) ²
Single-Ended			
3.3 V LVTTTL / 3.3 V LVCMOS	3.3	–	16.72
2.5 V LVCMOS	2.5	–	5.14
1.8 V LVCMOS	1.8	–	2.13
1.5 V LVCMOS (JESD8-11)	1.5	–	1.48
3.3 V PCI	3.3	–	18.13
3.3 V PCI-X	3.3	–	18.13

Notes:

1. P_{DC2} is the static power (where applicable) measured on VMV.
2. P_{AC9} is the total dynamic power measured on V_{CC} and VMV.

Table 2-9 • Summary of I/O Output Buffer Power (per pin) – Default I/O Software Settings¹
 Applicable to Advanced I/O Banks

	C_{LOAD} (pF)	VCCI (V)	Static Power PDC3 (mW) ²	Dynamic Power PAC10 (μW/MHz) ³
Single-Ended				
3.3 V LVTTTL / 3.3 V LVCMOS	35	3.3	–	468.67
2.5 V LVCMOS	35	2.5	–	267.48
1.8 V LVCMOS	35	1.8	–	149.46
1.5 V LVCMOS (JESD8-11)	35	1.5	–	103.12
3.3 V PCI	10	3.3	–	201.02
3.3 V PCI-X	10	3.3	–	201.02
Differential				
LVDS	–	2.5	7.74	88.92
LVPECL	–	3.3	19.54	166.52

Notes:

1. Dynamic power consumption is given for standard load and software default drive strength and output slew.
2. P_{DC3} is the static power (where applicable) measured on VMV.
3. P_{AC10} is the total dynamic power measured on V_{CCI} and VMV.

Table 2-10 • Summary of I/O Output Buffer Power (per pin) – Default I/O Software Settings ¹
Applicable to Standard Plus I/O Banks

	C_{LOAD} (pF)	VCCI (V)	Static Power PDC3 (mW) ²	Dynamic Power PAC10 (μ W/MHz) ³
Single-Ended				
3.3 V LVTTTL / 3.3 V LVCMOS	35	3.3	–	452.67
2.5 V LVCMOS	35	2.5	–	258.32
1.8 V LVCMOS	35	1.8	–	133.59
1.5 V LVCMOS (JESD8-11)	35	1.5	–	92.84
3.3 V PCI	10	3.3	–	184.92
3.3 V PCI-X	10	3.3	–	184.92

Notes:

1. Dynamic power consumption is given for standard load and software default drive strength and output slew.
2. PDC3 is the static power (where applicable) measured on VMV.
3. PAC10 is the total dynamic power measured on VCCI and VMV.

Power Consumption of Various Internal Resources

Table 2-11 • Different Components Contributing to Dynamic Power Consumption in ProASIC3 Devices

Parameter	Definition	Device Specific Dynamic Power (μW/MHz)			
		A3P1000	A3P250	A3P125	A3P060
PAC1	Clock contribution of a Global Rib	14.50	11.00	11.00	9.30
PAC2	Clock contribution of a Global Spine	2.48	1.58	0.81	0.81
PAC3	Clock contribution of a VersaTile row	0.81			
PAC4	Clock contribution of a VersaTile used as a sequential module	0.12			
PAC5	First contribution of a VersaTile used as a sequential module	0.07			
PAC6	Second contribution of a VersaTile used as a sequential module	0.29			
PAC7	Contribution of a VersaTile used as a combinatorial module	0.29			
PAC8	Average contribution of a routing net	0.70			
PAC9	Contribution of an I/O input pin (standard-dependent)	See Table 2-7 on page 2-6.			
PAC10	Contribution of an I/O output pin (standard-dependent)	See Table 2-7 and Table 2-10 on page 2-8.			
PAC11	Average contribution of a RAM block during a read operation	25.00			
PAC12	Average contribution of a RAM block during a write operation	30.00			
PAC13	Static PLL contribution	2.55 mW			
PAC14	Dynamic contribution for PLL	2.60			

Note: *For a different output load, drive strength, or slew rate, Microsemi recommends using the Microsemi power spreadsheet calculator or SmartPower tool in Libero SoC.

Power Calculation Methodology

This section describes a simplified method to estimate power consumption of an application. For more accurate and detailed power estimations, use the SmartPower tool in Libero SoC software.

The power calculation methodology described below uses the following variables:

- The number of PLLs as well as the number and the frequency of each output clock generated
- The number of combinatorial and sequential cells used in the design
- The internal clock frequencies
- The number and the standard of I/O pins used in the design
- The number of RAM blocks used in the design
- Toggle rates of I/O pins as well as VersaTiles—guidelines are provided in Table 2-12 on page 2-11.
- Enable rates of output buffers—guidelines are provided for typical applications in Table 2-13 on page 2-12.
- Read rate and write rate to the memory—guidelines are provided for typical applications in Table 2-13 on page 2-12. The calculation should be repeated for each clock domain defined in the design.

Methodology

Total Power Consumption— P_{TOTAL}

$$P_{TOTAL} = P_{STAT} + P_{DYN}$$

P_{STAT} is the total static power consumption.

P_{DYN} is the total dynamic power consumption.

Total Static Power Consumption— P_{STAT}

$$P_{STAT} = PDC1 + N_{INPUTS} * PDC2 + N_{OUTPUTS} * PDC3$$

N_{INPUTS} is the number of I/O input buffers used in the design.

$N_{OUTPUTS}$ is the number of I/O output buffers used in the design.

Total Dynamic Power Consumption— P_{DYN}

$$P_{DYN} = P_{CLOCK} + P_{S-CELL} + P_{C-CELL} + P_{NET} + P_{INPUTS} + P_{OUTPUTS} + P_{MEMORY} + P_{PLL}$$

Global Clock Contribution— P_{CLOCK}

$$P_{CLOCK} = (PAC1 + N_{SPINE} * PAC2 + N_{ROW} * PAC3 + N_{S-CELL} * PAC4) * F_{CLK}$$

N_{SPINE} is the number of global spines used in the user design—guidelines are provided in the "Spine Architecture" section of the Global Resources chapter in the *Automotive ProASIC3 FPGA Fabric User's Guide*.

N_{ROW} is the number of VersaTile rows used in the design—guidelines are provided in the *Automotive ProASIC3 FPGA Fabric User's Guide*.

F_{CLK} is the global clock signal frequency.

N_{S-CELL} is the number of VersaTiles used as sequential modules in the design.

PAC1, PAC2, PAC3, and PAC4 are device-dependent.

Sequential Cells Contribution— P_{S-CELL}

$$P_{S-CELL} = N_{S-CELL} * (PAC5 + \alpha_1 / 2 * PAC6) * F_{CLK}$$

N_{S-CELL} is the number of VersaTiles used as sequential modules in the design. When a multi-tile sequential cell is used, it should be accounted for as 1.

α_1 is the toggle rate of VersaTile outputs—guidelines are provided in [Table 2-12 on page 2-11](#).

F_{CLK} is the global clock signal frequency.

Combinatorial Cells Contribution— P_{C-CELL}

$$P_{C-CELL} = N_{C-CELL} * \alpha_1 / 2 * PAC7 * F_{CLK}$$

N_{C-CELL} is the number of VersaTiles used as combinatorial modules in the design.

α_1 is the toggle rate of VersaTile outputs—guidelines are provided in [Table 2-12 on page 2-11](#).

F_{CLK} is the global clock signal frequency.

Routing Net Contribution— P_{NET}

$$P_{NET} = (N_{S-CELL} + N_{C-CELL}) * \alpha_1 / 2 * PAC8 * F_{CLK}$$

N_{S-CELL} is the number VersaTiles used as sequential modules in the design.

N_{C-CELL} is the number of VersaTiles used as combinatorial modules in the design.

α_1 is the toggle rate of VersaTile outputs—guidelines are provided in [Table 2-12 on page 2-11](#).

F_{CLK} is the global clock signal frequency.

I/O Input Buffer Contribution— P_{INPUTS}

$$P_{INPUTS} = N_{INPUTS} * \alpha_2 / 2 * PAC9 * F_{CLK}$$

N_{INPUTS} is the number of I/O input buffers used in the design.

α_2 is the I/O buffer toggle rate—guidelines are provided in [Table 2-12 on page 2-11](#).

F_{CLK} is the global clock signal frequency.

I/O Output Buffer Contribution— P_{OUTPUTS}

$$P_{\text{OUTPUTS}} = N_{\text{OUTPUTS}} * \alpha_2 / 2 * \beta_1 * \text{PAC10} * F_{\text{CLK}}$$

N_{OUTPUTS} is the number of I/O output buffers used in the design.

α_2 is the I/O buffer toggle rate—guidelines are provided in Table 2-12.

β_1 is the I/O buffer enable rate—guidelines are provided in Table 2-13 on page 2-12.

F_{CLK} is the global clock signal frequency.

RAM Contribution— P_{MEMORY}

$$P_{\text{MEMORY}} = \text{PAC11} * N_{\text{BLOCKS}} * F_{\text{READ-CLOCK}} * \beta_2 + \text{PAC12} * N_{\text{BLOCK}} * F_{\text{WRITE-CLOCK}} * \beta_3$$

N_{BLOCKS} is the number of RAM blocks used in the design.

$F_{\text{READ-CLOCK}}$ is the memory read clock frequency.

β_2 is the RAM enable rate for read operations.

$F_{\text{WRITE-CLOCK}}$ is the memory write clock frequency.

β_3 is the RAM enable rate for write operations—guidelines are provided in Table 2-13 on page 2-12.

PLL Contribution— P_{PLL}

$$P_{\text{PLL}} = \text{PAC13} + \text{PAC14} * F_{\text{CLKOUT}}$$

F_{CLKIN} is the input clock frequency.

F_{CLKOUT} is the output clock frequency.¹

Guidelines

Toggle Rate Definition

A toggle rate defines the frequency of a net or logic element relative to a clock. It is a percentage. If the toggle rate of a net is 100%, this means that this net switches at half the clock frequency. Below are some examples:

- The average toggle rate of a shift register is 100% because all flip-flop outputs toggle at half of the clock frequency.
- The average toggle rate of an 8-bit counter is 25%:
 - Bit 0 (LSB) = 100%
 - Bit 1 = 50%
 - Bit 2 = 25%
 - ...
 - Bit 7 (MSB) = 0.78125%
 - Average toggle rate = (100% + 50% + 25% + 12.5% + . . . + 0.78125%) / 8

Enable Rate Definition

Output enable rate is the average percentage of time during which tristate outputs are enabled. When nontristate output buffers are used, the enable rate should be 100%.

Table 2-12 • Toggle Rate Guidelines Recommended for Power Calculation

Component	Definition	Guideline
α_1	Toggle rate of VersaTile outputs	10%
α_2	I/O buffer toggle rate	10%

1. The PLL dynamic contribution depends on the input clock frequency, the number of output clock signals generated by the PLL, and the frequency of each output clock. If a PLL is used to generate more than one output clock, include each output clock in the formula by adding its corresponding contribution ($\text{PAC14} * F_{\text{CLKOUT}}$ product) to the total PLL contribution.

Table 2-13 • Enable Rate Guidelines Recommended for Power Calculation

Component	Definition	Guideline
β_1	I/O output buffer enable rate	100%
β_2	RAM enable rate for read operations	12.5%
β_3	RAM enable rate for write operations	12.5%

User I/O Characteristics

Timing Model

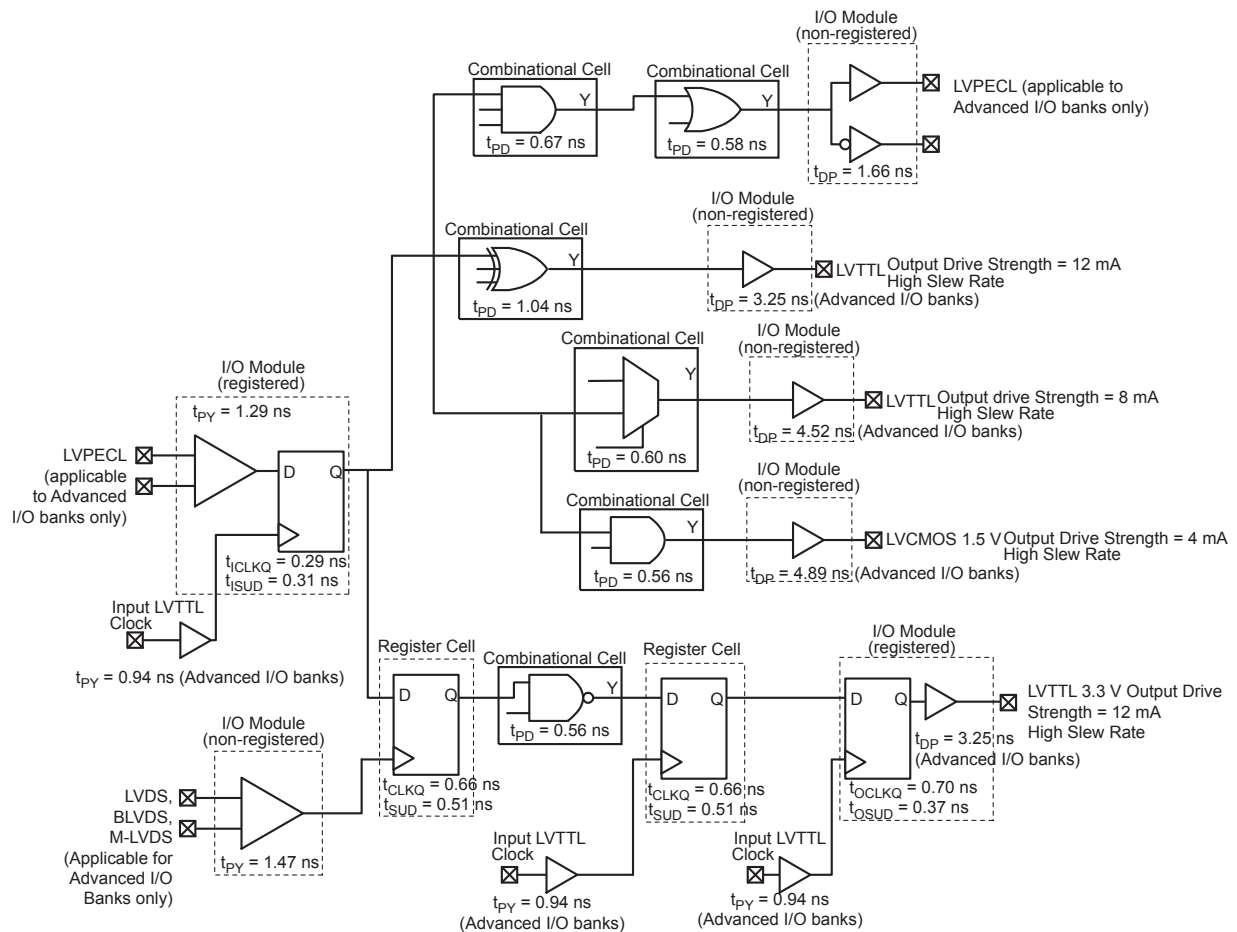
Figure 2-3 • Timing Model

Operating Conditions: -1 Speed, Automotive Grade 2 Temp. Range ($T_J = 115^\circ\text{C}$), Worst Case
 VCC = 1.425 V

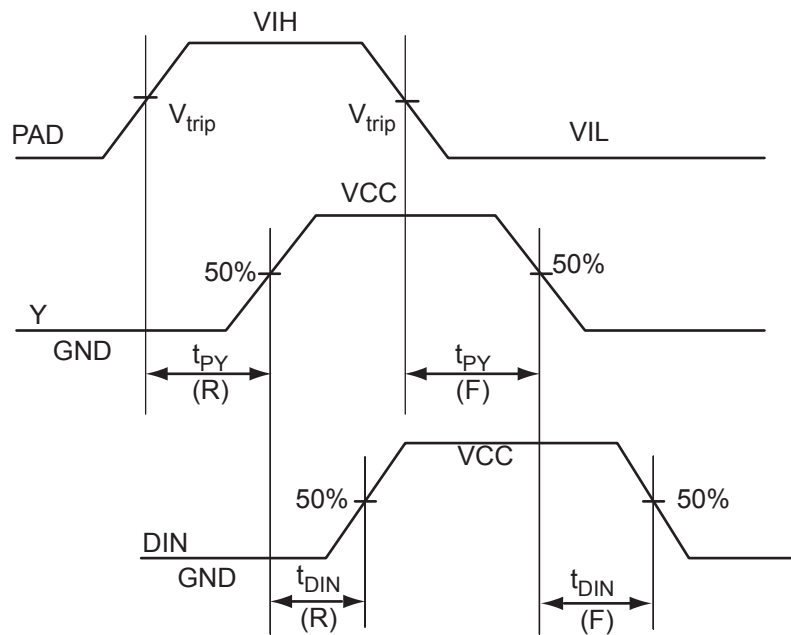
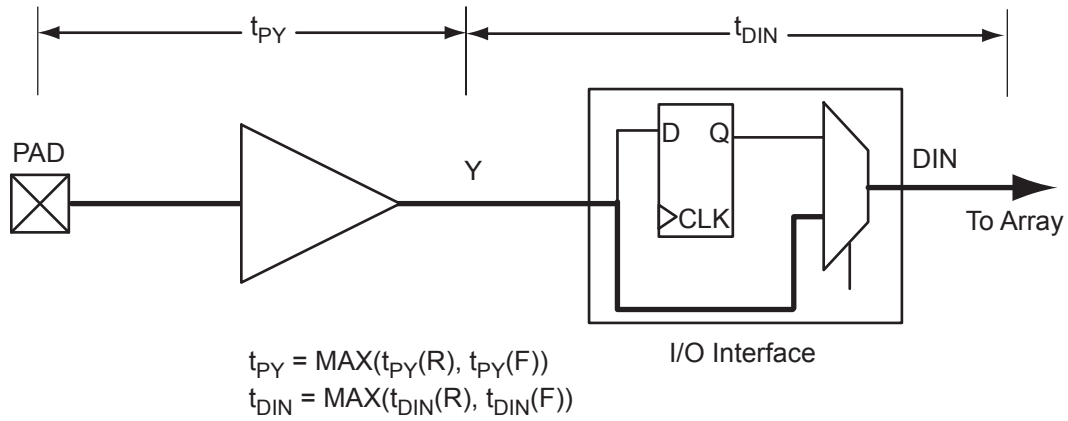
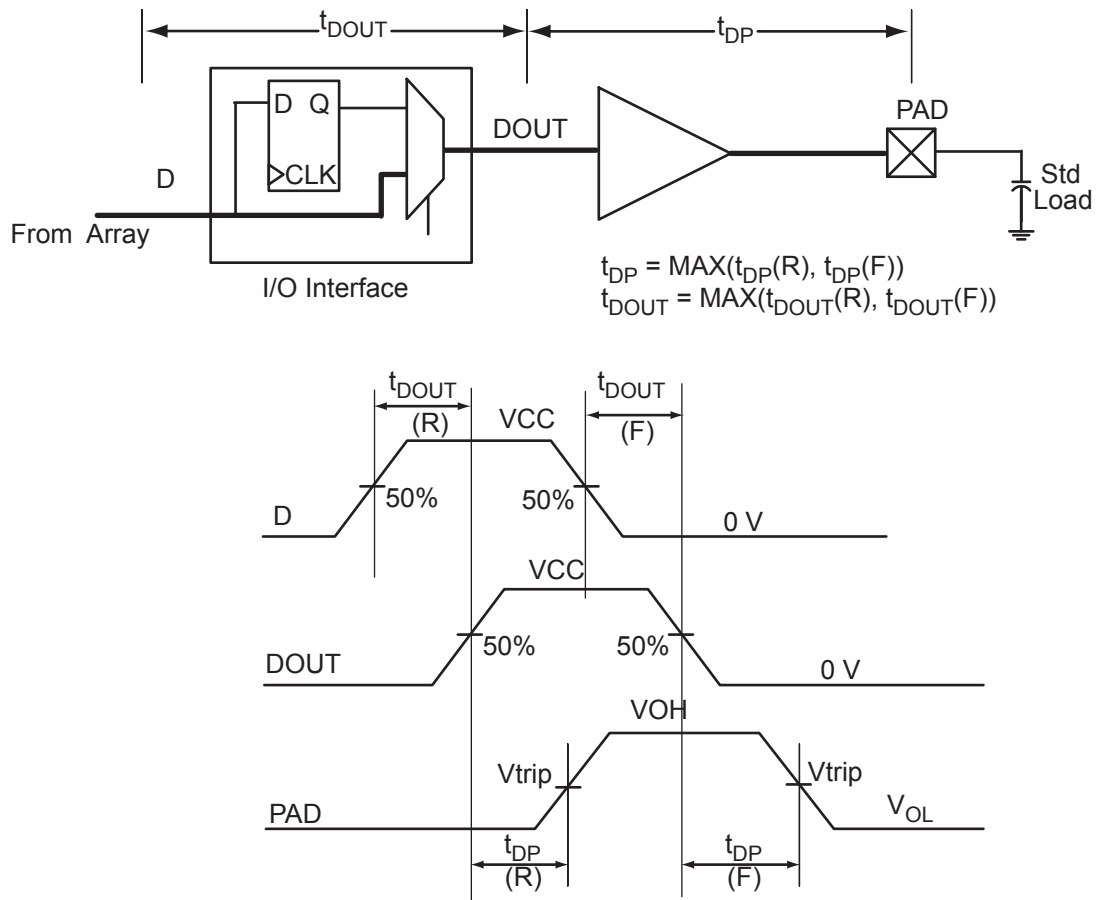

Figure 2-4 • Input Buffer Timing Model and Delays (example)

Figure 2-5 • Output Buffer Model and Delays (example)

Overview of I/O Performance

Summary of I/O DC Input and Output Levels – Default I/O Software Settings

Table 2-14 • Summary of Maximum and Minimum DC Input and Output Levels Applicable to Commercial and Industrial Conditions—Software Default Settings
Applicable to Advanced I/O Banks

I/O Standard	Drive Strength	Slew Rate	VIL		VIH		VOL	VOH	I _{OL}	I _{OH}
			Min. V	Max. V	Min. V	Max. V	Max. V	Min. V	mA	mA
3.3 V LVTTTL / 3.3 V LVCMOS	12 mA	High	-0.3	0.8	2	3.6	0.4	2.4	12	12
2.5 V LVCMOS	12 mA	High	-0.3	0.7	1.7	3.6	0.7	1.7	12	12
1.8 V LVCMOS	12 mA	High	-0.3	0.35 * V _{CCI}	0.65 * V _{CCI}	3.6	0.45	V _{CCI} - 0.45	12	12
1.5 V LVCMOS	12 mA	High	-0.3	0.30 * V _{CCI}	0.7 * V _{CCI}	3.6	0.25 * V _{CCI}	0.75 * V _{CCI}	12	12
3.3 V PCI	Per PCI specifications									
3.3 V PCI-X	Per PCI-X specifications									

Note: Currents are measured at 125°C junction temperature.

Table 2-15 • Summary of Maximum and Minimum DC Input and Output Levels Applicable to Commercial and Industrial Conditions—Software Default Settings
Applicable to Standard Plus I/O Banks

I/O Standard	Drive Strength	Slew Rate	VIL		VIH		VOL	VOH	I _{OL}	I _{OH}
			Min. V	Max. V	Min. V	Max. V	Max. V	Min. V	mA	mA
3.3 V LVTTTL / 3.3 V LVCMOS	12 mA	High	-0.3	0.8	2	3.6	0.4	2.4	12	12
2.5 V LVCMOS	12 mA	High	-0.3	0.7	1.7	3.6	0.7	1.7	12	12
1.8 V LVCMOS	8 mA	High	-0.3	0.35 * V _{CCI}	0.65 * V _{CCI}	3.6	0.45	V _{CCI} - 0.45	8	8
1.5 V LVCMOS	4 mA	High	-0.3	0.30 * V _{CCI}	0.7 * V _{CCI}	3.6	0.25 * V _{CCI}	0.75 * V _{CCI}	4	4
3.3 V PCI	Per PCI specifications									
3.3 V PCI-X	Per PCI-X specifications									

Note: Currents are measured at 125°C junction temperature.

Table 2-16 • Summary of Maximum and Minimum DC Input and Output Levels Applicable to Commercial and Industrial Conditions—Software Default Settings
Applicable to Standard I/O Banks

I/O Standard	Drive Strength	Slew Rate	VIL		VIH		VOL	VOH	I _{OL}	I _{OH}
			Min. V	Max. V	Min. V	Max. V	Max. V	Min. V	mA	mA
3.3 V LVTTTL / 3.3 V LVCMOS	8 mA	High	-0.3	0.8	2	3.6	0.4	2.4	8	8
2.5 V LVCMOS	8 mA	High	-0.3	0.7	1.7	3.6	0.7	1.7	8	8
1.8 V LVCMOS	4 mA	High	-0.3	0.35 * VCCI	0.65 * VCCI	3.6	0.45	VCCI - 0.45	4	4
1.5 V LVCMOS	2 mA	High	-0.3	0.30 * VCCI	0.7 * VCCI	3.6	0.25 * VCCI	0.75 * VCCI	2	2

Note: Currents are measured at 125°C junction temperature.

Table 2-17 • Summary of Maximum and Minimum DC Input Levels Applicable to Automotive Grade 1 and Grade 2

DC I/O Standards	Automotive Grade 1 ¹		Automotive Grade 2 ²	
	IIL	IIH	IIL	IIH
	µA	µA	µA	µA
3.3 V LVTTTL / 3.3 V LVCMOS	10	10	15	15
2.5 V LVCMOS	10	10	15	15
1.8 V LVCMOS	10	10	15	15
1.5 V LVCMOS	10	10	15	15
3.3 V PCI	10	10	15	15
3.3 V PCI-X	10	10	15	15

Notes:

1. Automotive range Grade 1 (-40°C < T_J < 135°C)
2. Automotive range Grade 2 (-40°C < T_J < 115°C)

Summary of I/O Timing Characteristics – Default I/O Software Settings

Table 2-18 • Summary of AC Measuring Points

Standard	Measuring Trip Point (Vtrip)
3.3 V LVTTTL / 3.3 V LVCMOS	1.4 V
2.5 V LVCMOS	1.2 V
1.8 V LVCMOS	0.90 V
1.5 V LVCMOS	0.75 V
3.3 V PCI	0.285 * VCCI (RR)
	0.615 * VCCI (FF)
3.3 V PCI-X	0.285 * VCCI (RR)
	0.615 * VCCI (FF)

Table 2-19 • I/O AC Parameter Definitions

Parameter	Parameter Definition
t_{DP}	Data-to-Pad delay through the Output Buffer
t_{PY}	Pad-to-Data delay through the Input Buffer
t_{DOUT}	Data-to-Output Buffer delay through the I/O interface
t_{EOUT}	Enable-to-Output Buffer Tristate Control delay through the I/O interface
t_{DIN}	Input Buffer-to-Data delay through the I/O interface
t_{HZ}	Enable-to-Pad delay through the Output Buffer—High to Z
t_{ZH}	Enable-to-Pad delay through the Output Buffer—Z to High
t_{LZ}	Enable-to-Pad delay through the Output Buffer—Low to Z
t_{ZL}	Enable-to-Pad delay through the Output Buffer—Z to Low
t_{ZHS}	Enable-to-Pad delay through the Output Buffer with delayed enable—Z to High
t_{ZLS}	Enable-to-Pad delay through the Output Buffer with delayed enable—Z to Low

Table 2-20 • Summary of I/O Timing Characteristics—Software Default Settings
 –1 Speed Grade, Automotive-Case Conditions: $T_j = 115^\circ\text{C}$, Worst Case VCC = 1.425 V
 Worst Case VCCI = 3.0 V
 Advanced I/O Banks

I/O Standard	Drive Strength (mA)	Slew Rate	Capacitive Load (pF)	External Resistor (Ω)	t_{DOUT} (ns)	t_{DP} (ns)	t_{DIN} (ns)	t_{PY} (ns)	t_{EOUT} (ns)	t_{ZL} (ns)	t_{ZH} (ns)	t_{LZ} (ns)	t_{HZ} (ns)	t_{ZLS} (ns)	t_{ZHS} (ns)	Units
3.3 V LVTTTL / 3.3 V LVCMOS	12 mA	High	35 pF	–	0.53	3.25	0.04	0.94	0.38	3.31	1.51	2.96	1.88	5.37	2.71	ns
2.5 V LVCMOS	12 mA	High	35 pF	–	0.53	3.28	0.04	1.19	0.38	3.34	3.16	1.77	1.80	5.39	5.22	ns
1.8 V LVCMOS	12 mA	High	35 pF	–	0.53	3.25	0.04	1.12	0.38	1.89	1.63	3.41	3.75	3.06	2.82	ns
1.5 V LVCMOS	12 mA	High	35 pF	–	0.53	3.75	0.04	1.32	0.38	2.18	1.91	3.63	3.87	3.35	3.11	ns
3.3 V PCI	Per PCI spec	High	10 pF	25 ²	0.53	2.12	0.04	0.78	0.38	1.23	0.91	2.57	2.96	2.41	2.11	ns
3.3 V PCI-X	Per PCI-X spec	High	10 pF	25 ²	0.53	2.47	0.04	0.77	0.38	1.23	0.91	2.57	2.96	2.41	2.11	ns
LVDS	24 mA	High	–	–	0.53	1.68	0.04	1.47	–	–	–	–	–	–	–	ns
LVPECL	24 mA	High	–	–	0.53	1.66	0.04	1.29	–	–	–	–	–	–	–	ns

Notes:

1. For specific junction temperature and voltage supply levels, refer to [Table 2-5 on page 2-5](#) for derating values.
2. Resistance is used to measure I/O propagation delays as defined in PCI specifications. See [Figure 2-11 on page 2-48](#) for connectivity. This resistor is not required during normal operation.

Table 2-21 • Summary of I/O Timing Characteristics—Software Default Settings
 –1 Speed Grade, Automotive-Case Conditions: $T_J = 115^\circ\text{C}$, Worst Case VCC = 1.425 V
 Worst Case VCCI = 3.0 V
 Standard Plus I/O Banks

I/O Standard	Drive Strength (mA)	Slew Rate	Capacitive Load (pF)	External Resistor	t_{DOUT}	t_{DP}	t_{DIN}	t_{PY}	t_{EOUT}	t_{ZL}	t_{ZH}	t_{LZ}	t_{HZ}	t_{ZLS}	t_{ZHS}	Units
3.3 V LVTTTL / 3.3 V LVCMOS	12 mA	High	35 pF	–	0.55	3.01	0.04	0.95	0.39	1.74	1.43	2.65	3.06	1.74	1.43	ns
2.5 V LVCMOS	12 mA	High	35 pF	–	0.55	3.05	0.04	1.23	0.39	3.11	2.99	1.56	1.69	5.23	5.11	ns
1.8 V LVCMOS	8 mA	High	35 pF	–	0.55	3.73	0.04	1.16	0.39	3.65	3.86	1.62	1.68	5.78	5.99	ns
1.5 V LVCMOS	4 mA	High	35 pF	–	0.55	4.60	0.04	1.35	0.39	4.61	5.05	2.07	1.85	6.74	7.18	ns
3.3 V PCI	Per PCI spec	High	10 pF	25 ²	0.55	2.19	0.04	0.81	0.39	1.27	0.94	2.65	3.06	1.27	0.94	ns
3.3 V PCI-X	Per PCI-X spec	High	10 pF	25 ²	0.55	2.19	0.04	0.79	0.39	1.27	0.94	2.65	3.06	1.27	0.94	ns

Notes:

1. For specific junction temperature and voltage supply levels, refer to [Table 2-5 on page 2-5](#) for derating values.
2. Resistance is used to measure I/O propagation delays as defined in PCI specifications. See [Figure 2-11 on page 2-48](#) for connectivity. This resistor is not required during normal operation.

Table 2-22 • Summary of I/O Timing Characteristics—Software Default Settings
 –1 Speed Grade, Automotive-Case Conditions: $T_J = 135^{\circ}\text{C}$, Worst Case $V_{CC} = 1.425\text{ V}$
 Worst Case $V_{CCI} = 3.0\text{ V}$
 Advanced I/O Banks

I/O Standard	Drive Strength (mA)	Slew Rate	Capacitive Load (pF)	External Resistor (Ω)	t_{DOUT} (ns)	t_{DP} (ns)	t_{DIN} (ns)	t_{PY} (ns)	t_{EOUT} (ns)	t_{ZL} (ns)	t_{ZH} (ns)	t_{LZ} (ns)	t_{HZ} (ns)	t_{ZLS} (ns)	t_{ZHS} (ns)	Units
3.3 V LVTTTL / 3.3 V LVCMOS	12 mA	High	35 pF	–	0.55	3.36	0.04	0.97	0.39	3.42	1.56	3.05	1.94	5.55	2.80	ns
2.5 V LVCMOS	12 mA	High	35 pF	–	0.55	3.39	0.04	1.23	0.39	3.45	3.27	1.83	1.86	5.58	5.39	ns
1.8 V LVCMOS	12 mA	High	35 pF	–	0.55	3.36	0.04	1.16	0.39	1.95	1.68	3.52	3.88	3.16	2.92	ns
1.5 V LVCMOS	12 mA	High	35 pF	–	0.55	3.88	0.04	1.37	0.39	2.25	1.98	3.75	4.00	3.46	3.21	ns
3.3 V PCI	Per PCI spec	High	10 pF	25 ²	0.55	2.19	0.04	0.81	0.39	1.27	0.94	2.65	3.06	2.49	2.18	ns
3.3 V PCI-X	Per PCI-X spec	High	10 pF	25 ²	0.55	2.55	0.04	0.79	0.39	1.27	0.94	2.65	3.06	2.49	2.18	ns
LVDS	24 mA	High	–	–	0.55	1.74	0.04	1.52	–	–	–	–	–	–	–	ns
LVPECL	24 mA	High	–	–	0.55	1.71	0.04	1.34	–	–	–	–	–	–	–	ns

Notes:

1. For specific junction temperature and voltage supply levels, refer to [Table 2-5 on page 2-5](#) for derating values.
2. Resistance is used to measure I/O propagation delays as defined in PCI specifications. See [Figure 2-11 on page 2-48](#) for connectivity. This resistor is not required during normal operation.

Table 2-23 • Summary of I/O Timing Characteristics—Software Default Settings
 –1 Speed Grade, Automotive-Case Conditions: $T_J = 115^\circ\text{C}$, Worst Case VCC = 1.425 V
 Worst Case VCCI = 3.0 V
 Standard Plus I/O Banks

I/O Standard	Drive Strength (mA)	Slew Rate	Capacitive Load (pF)	External Resistor	t _{BOU} (ns)	t _{DP} (ns)	t _{DIN} (ns)	t _{PY} (ns)	t _{EOUT} (ns)	t _{ZL} (ns)	t _{ZH} (ns)	t _{LZ} (ns)	t _{HZ} (ns)	t _{ZLS} (ns)	t _{ZHS} (ns)	Units
3.3 V LVTTTL / 3.3 V LVCMOS	12 mA	High	35 pF	–	0.55	3.36	0.04	0.97	0.39	3.42	1.56	3.05	1.94	5.55	2.80	ns
2.5 V LVCMOS	12 mA	High	35 pF	–	0.55	3.05	0.04	1.23	0.39	3.11	2.99	1.56	1.69	5.23	5.11	ns
1.8 V LVCMOS	8 mA	High	35 pF	–	0.55	3.73	0.04	1.16	0.39	3.65	3.86	1.62	1.68	5.78	5.99	ns
1.5 V LVCMOS	4 mA	High	35 pF	–	0.55	4.60	0.04	1.35	0.39	4.61	5.05	2.07	1.85	6.74	7.18	ns
3.3 V PCI	Per PCI spec	High	10 pF	25 ²	0.55	2.55	0.04	0.82	0.39	1.27	0.94	2.65	3.06	2.49	2.18	ns
3.3 V PCI-X	Per PCI-X spec	High	10 pF	25 ²	0.55	2.55	0.04	0.79	0.39	1.27	0.94	2.65	3.06	2.49	2.18	ns

Notes:

1. For specific junction temperature and voltage supply levels, refer to [Table 2-5 on page 2-5](#) for derating values.
2. Resistance is used to measure I/O propagation delays as defined in PCI specifications. See [Figure 2-11 on page 2-48](#) for connectivity. This resistor is not required during normal operation.

Detailed I/O DC Characteristics

Table 2-24 • Input Capacitance

Symbol	Definition	Conditions	Min.	Max.	Units
C_{IN}	Input capacitance	$V_{IN} = 0, f = 1.0 \text{ MHz}$		8	pF
C_{INCLK}	Input capacitance on the clock pin	$V_{IN} = 0, f = 1.0 \text{ MHz}$		8	pF

**Table 2-25 • I/O Output Buffer Maximum Resistances¹
Applicable to Advanced I/O Banks**

Standard	Drive Strength	$R_{PULL-DOWN}$ (Ω) ²	$R_{PULL-UP}$ (Ω) ³
3.3 V LVTTTL / 3.3 V LVCMOS	2 mA	100	300
	4 mA	100	300
	6 mA	50	150
	8 mA	50	150
	12 mA	25	75
	16 mA	17	50
	24 mA	11	33
2.5 V LVCMOS	2 mA	100	200
	6 mA	50	100
	12 mA	25	50
	16 mA	20	40
	24 mA	11	22
1.8 V LVCMOS	2 mA	200	225
	4 mA	100	112
	6 mA	50	56
	8 mA	50	56
	12 mA	20	22
	16 mA	20	22
1.5 V LVCMOS	2 mA	200	224
	4 mA	100	112
	6 mA	67	75
	8 mA	33	37
	12 mA	33	37
3.3 V PCI/PCI-X	Per PCI/PCI-X specification	25	75

Notes:

1. These maximum values are provided for informational reasons only. Minimum output buffer resistance values depend on V_{CCJ} , drive strength selection, temperature, and process. For board design considerations and detailed output buffer resistances, use the corresponding IBIS models located at <http://www.microsemi.com/soc/download/ibis/default.aspx>.
2. $R_{(PULL-DOWN-MAX)} = (VOL_{spec}) / I_{OL_{spec}}$
3. $R_{(PULL-UP-MAX)} = (VCCImax - VOH_{spec}) / I_{OH_{spec}}$

Table 2-26 • I/O Output Buffer Maximum Resistances¹
 Applicable to Standard Plus I/O Banks

Standard	Drive Strength	R _{PULL-DOWN} (Ω) ²	R _{PULL-UP} (Ω) ³
3.3 V LVTTTL / 3.3 V LVCMOS	2 mA	100	300
	4 mA	100	300
	6 mA	50	150
	8 mA	50	150
	12 mA	25	75
	16 mA	25	75
2.5 V LVCMOS	2 mA	100	200
	6 mA	50	100
	12 mA	25	50
1.8 V LVCMOS	2 mA	200	225
	4 mA	100	112
	6 mA	50	56
	8 mA	50	56
1.5 V LVCMOS	2 mA	200	224
	4 mA	100	112
3.3 V PCI/PCI-X	Per PCI/PCI-X specification	0	0

Notes:

1. These maximum values are provided for informational reasons only. Minimum output buffer resistance values depend on VCCI, drive strength selection, temperature, and process. For board design considerations and detailed output buffer resistances, use the corresponding IBIS models located at <http://www.microsemi.com/soc/download/ibis/default.aspx>.
2. $R_{(PULL-DOWN-MAX)} = (VOL_{spec}) / IOL_{spec}$
3. $R_{(PULL-UP-MAX)} = (VCCI_{max} - VOH_{spec}) / IOH_{spec}$

Table 2-27 • I/O Weak Pull-Up/Pull-Down Resistances
 Minimum and Maximum Weak Pull-Up/Pull-Down Resistance Values

VCCI	R _(WEAK PULL-UP) ¹ (Ω)		R _(WEAK PULL-DOWN) ² (Ω)	
	Min.	Max.	Min.	Max.
3.3 V	10 k	45 k	10 k	45 k
2.5 V	11 k	55 k	12 k	74 k
1.8 V	18 k	70 k	17 k	110 k
1.5 V	19 k	90 k	19 k	140 k

Notes:

1. $R_{(WEAK PULL-UP-MAX)} = (VCCI_{max} - VOH_{spec}) / I_{(WEAK PULL-UP-MIN)}$
2. $R_{(WEAK PULL-DOWN-MAX)} = (VOL_{spec}) / I_{(WEAK PULL-DOWN-MIN)}$

**Table 2-28 • I/O Short Currents IOSH/IOSL
Applicable to Advanced I/O Banks**

	Drive Strength	IOSL (mA)*	IOSH (mA)*
3.3 V LVTTTL / 3.3 V LVCMOS	2 mA	27	25
	4 mA	27	25
	6 mA	54	51
	8 mA	54	51
	12 mA	109	103
	16 mA	127	132
	24 mA	181	268
3.3 V LVCMOS	2 mA	27	25
	4 mA	27	25
	6 mA	54	51
	8 mA	54	51
	12 mA	109	103
	16 mA	127	132
	24 mA	181	268
2.5 V LVCMOS	2 mA	18	16
	6 mA	37	32
	12 mA	74	65
	16 mA	87	83
	24 mA	124	169
1.8 V LVCMOS	2 mA	11	9
	4 mA	22	17
	6 mA	44	35
	8 mA	51	45
	12 mA	74	91
	16 mA	74	91
1.5 V LVCMOS	2 mA	16	13
	4 mA	33	25
	6 mA	39	32
	8 mA	55	66
	12 mA	55	66
3.3 V PCI/PCI-X	Per PCI/PCI-X specification	109	103

Note: * $T_J = 100^\circ\text{C}$

Table 2-29 • I/O Short Currents I_{OSH}/I_{OSL}
Applicable to Standard Plus I/O Banks

	Drive Strength	I _{OSL} (mA)*	I _{OSH} (mA)*
3.3 V LVTTTL / 3.3 V LVCMOS	2 mA	27	25
	4 mA	27	25
	6 mA	54	51
	8 mA	54	51
	12 mA	109	103
	16 mA	109	103
2.5 V LVCMOS	2 mA	18	16
	6 mA	37	32
	12 mA	74	65
1.8 V LVCMOS	2 mA	11	9
	4 mA	22	17
	6 mA	44	35
	8 mA	44	35
1.5 V LVCMOS	2 mA	16	13
	4 mA	33	25
3.3 V PCI/PCI-X	Per PCI/PCI-X specification	109	103

Note: * $T_J = 100^\circ\text{C}$

The length of time an I/O can withstand I_{OSH}/I_{OSL} events depends on the junction temperature. The reliability data below is based on a 3.3 V, 12 mA I/O setting, which is the worst case for this type of analysis.

For example, at 110°C, the short current condition would have to be sustained for more than three months to cause a reliability concern. The I/O design does not contain any short circuit protection, but such protection would only be needed in extremely prolonged stress conditions.

Table 2-30 • Duration of Short Circuit Event before Failure

Temperature	Time before Failure
-40°C	> 20 years
0°C	> 20 years
25°C	> 20 years
70°C	5 years
85°C	2 years
100°C	6 months
110°C	3 months
125°C	25 days
135°	12 days

Table 2-31 • I/O Input Rise Time, Fall Time, and Related I/O Reliability

Input Buffer	Input Rise/Fall Time (min.)	Input Rise/Fall Time (max.)	Reliability
LVTTTL/LVCMOS	No requirement	10 ns *	20 years (110°C)
LVDS/B-LVDS/M-LVDS/LVPECL	No requirement	10 ns *	10 years (100°C)

Note: *The maximum input rise/fall time is related to the noise induced into the input buffer trace. If the noise is low, the rise time and fall time of input buffers can be increased beyond the maximum value. The longer the rise/fall times, the more susceptible the input signal is to the board noise. Microsemi recommends signal integrity evaluation/characterization of the system to ensure there is no excessive noise coupling into input signals.

Single-Ended I/O Characteristics

3.3 V LVTTTL / 3.3 V LVCMOS

Low-Voltage Transistor–Transistor Logic (LVTTTL) is a general-purpose standard (EIA/JESD) for 3.3 V applications. It uses an LVTTTL input buffer and push-pull output buffer.

Table 2-32 • Minimum and Maximum DC Input and Output Levels
Applicable to Advanced I/O Banks

3.3 V LVTTTL / 3.3 V LVCMOS	VIL		VIH		VOL	VOH	I _{OL}	I _{OH}	I _{OSL}	I _{OSH}	I _{IL}	I _{IH}
	Min. V	Max. V	Min. V	Max. V	Max. V	Min. V	mA	mA	Max. mA ¹	Max. mA ¹	μA ²	μA ²
2 mA	-0.3	0.8	2	3.6	0.4	2.4	2	2	27	25	10	10
4 mA	-0.3	0.8	2	3.6	0.4	2.4	4	4	27	25	10	10
6 mA	-0.3	0.8	2	3.6	0.4	2.4	6	6	54	51	10	10
8 mA	-0.3	0.8	2	3.6	0.4	2.4	8	8	54	51	10	10
12 mA	-0.3	0.8	2	3.6	0.4	2.4	12	12	109	103	10	10
16 mA	-0.3	0.8	2	3.6	0.4	2.4	16	16	127	132	10	10
24 mA	-0.3	0.8	2	3.6	0.4	2.4	24	24	181	268	10	10

Notes:

1. Currents are measured at high temperature (100°C junction temperature) and maximum voltage.
2. Currents are measured at 125°C junction temperature.
3. Software default selection highlighted in gray.

Table 2-33 • Minimum and Maximum DC Input and Output Levels
Applicable to Standard Plus I/O Banks

3.3 V LVTTTL / 3.3 V LVCMOS	VIL		VIH		VOL	VOH	I _{OL}	I _{OH}	I _{OSL}	I _{OSH}	I _{IL}	I _{IH}
	Min. V	Max. V	Min. V	Max. V	Max. V	Min. V	mA	mA	Max. mA ¹	Max. mA ¹	μA ²	μA ²
2 mA	-0.3	0.8	2	3.6	0.4	2.4	2	2	27	25	10	10
4 mA	-0.3	0.8	2	3.6	0.4	2.4	4	4	27	25	10	10
6 mA	-0.3	0.8	2	3.6	0.4	2.4	6	6	54	51	10	10
8 mA	-0.3	0.8	2	3.6	0.4	2.4	8	8	54	51	10	10
12 mA	-0.3	0.8	2	3.6	0.4	2.4	12	12	109	103	10	10
16 mA	-0.3	0.8	2	3.6	0.4	2.4	16	16	109	103	10	10

Notes:

1. Currents are measured at high temperature (100°C junction temperature) and maximum voltage.
2. Currents are measured at 125°C junction temperature.
3. Software default selection highlighted in gray.

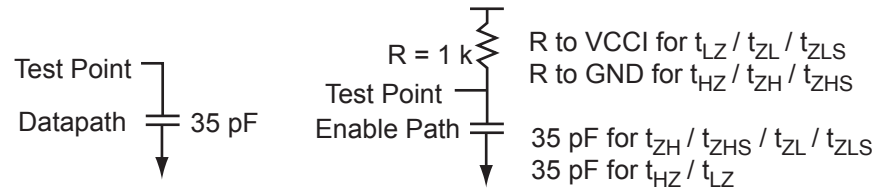
Figure 2-7 • AC Loading
Table 2-34 • AC Waveforms, Measuring Points, and Capacitive Loads

Input Low (V)	Input High (V)	Measuring Point* (V)	C _{LOAD} (pF)
0	3.3	1.4	35

Note: *Measuring point = V_{trip} . See Table 2-18 on page 2-17 for a complete table of trip points.

Timing Characteristics

Table 2-35 • 3.3 V LVTTTL / 3.3 V LVCMOS High Slew
 Automotive-Case Conditions: $T_J = 135^\circ\text{C}$, Worst-Case $V_{CC} = 1.425\text{ V}$, Worst-Case $V_{CCI} = 3.0\text{ V}$
 Applicable to Advanced I/O Banks

Drive Strength	Speed Grade	t_{DOUT}	t_{DP}	t_{DIN}	t_{PY}	t_{EOUT}	t_{ZL}	t_{ZH}	t_{LZ}	t_{HZ}	t_{ZLS}	t_{ZHS}	Units
4 mA	STD	0.64	8.56	0.05	1.14	0.46	8.72	7.37	1.46	1.42	11.22	9.866	ns
	-1	0.55	7.28	0.04	0.97	0.39	7.42	6.27	1.46	1.42	9.54	8.393	ns
6 mA	STD	0.64	5.49	0.05	1.14	0.46	5.59	4.55	1.65	1.74	8.09	7.05	ns
	-1	0.55	4.67	0.04	0.97	0.39	4.75	3.87	1.65	1.74	6.88	5.997	ns
8 mA	STD	0.64	5.49	0.05	1.14	0.46	5.59	4.55	1.65	1.74	8.09	7.05	ns
	-1	0.55	4.67	0.04	0.97	0.39	4.75	3.87	1.65	1.74	6.88	5.997	ns
12 mA	STD	0.64	3.95	0.05	1.14	0.46	4.02	1.56	3.59	1.94	6.52	2.795	ns
	-1	0.55	3.36	0.04	0.97	0.39	3.42	1.56	3.05	1.94	5.55	2.797	ns
16 mA	STD	0.64	3.73	0.05	1.14	0.46	1.84	1.42	3.65	4.11	3.05	2.651	ns
	-1	0.55	3.17	0.04	0.97	0.39	1.84	1.42	3.10	3.50	3.05	2.653	ns
24 mA	STD	0.64	3.44	0.05	1.14	0.46	1.70	1.17	3.72	4.54	2.91	2.405	ns
	-1	0.55	2.92	0.04	0.97	0.39	1.70	1.17	3.16	3.86	2.91	2.407	ns

Notes:

1. Software default selection highlighted in gray.
2. For specific junction temperature and voltage supply levels, refer to [Table 2-5 on page 2-5](#) for derating values.

Table 2-36 • 3.3 V LVTTTL / 3.3 V LVCMOS Low Slew
 Automotive-Case Conditions: $T_J = 135^\circ\text{C}$, Worst-Case $V_{CC} = 1.425\text{ V}$, Worst-Case $V_{CCI} = 3.0\text{ V}$
 Applicable to Advanced I/O Banks

Drive Strength	Speed Grade	t_{DOUT}	t_{DP}	t_{DIN}	t_{PY}	t_{EOUT}	t_{ZL}	t_{ZH}	t_{LZ}	t_{HZ}	t_{ZLS}	t_{ZHS}	Units
4 mA	STD	0.64	11.47	0.05	1.14	0.46	11.68	9.95	1.46	1.33	14.18	12.449	ns
	-1	0.55	9.75	0.04	0.97	0.39	9.94	8.46	1.46	1.33	12.06	10.59	ns
6 mA	STD	0.64	8.13	0.05	1.14	0.46	8.28	7.03	1.65	1.65	10.79	9.526	ns
	-1	0.55	6.92	0.04	0.97	0.39	7.05	5.98	1.65	1.65	9.17	8.103	ns
8 mA	STD	0.64	8.13	0.05	1.14	0.46	8.28	7.03	1.65	1.65	10.79	9.526	ns
	-1	0.55	6.92	0.04	0.97	0.39	7.05	5.98	1.65	1.65	9.17	8.103	ns
12 mA	STD	0.64	6.24	0.05	1.14	0.46	6.36	5.45	1.77	1.85	8.86	7.946	ns
	-1	0.55	5.31	0.04	0.97	0.39	5.41	4.63	1.77	1.85	7.53	6.76	ns
16 mA	STD	0.64	5.82	0.05	1.14	0.46	5.93	5.10	1.80	1.90	8.43	7.604	ns
	-1	0.55	4.95	0.04	0.97	0.39	5.04	4.34	1.80	1.90	7.17	6.468	ns
24 mA	STD	0.64	5.42	0.05	1.14	0.46	5.52	5.08	1.83	2.10	8.02	7.581	ns
	-1	0.55	4.61	0.04	0.97	0.39	4.70	4.32	1.83	2.11	6.82	6.449	ns

Note: For specific junction temperature and voltage supply levels, refer to [Table 2-5 on page 2-5](#) for derating values.

Table 2-37 • 3.3 V LVTTTL / 3.3 V LVCMOS High Slew
 Automotive-Case Conditions: $T_J = 135^\circ\text{C}$, Worst-Case VCC = 1.425 V, Worst-Case VCCI = 3.0 V
 Applicable to Standard Plus I/O Banks

Drive Strength	Speed Grade	t_{DOUT}	t_{DP}	t_{DIN}	t_{PY}	t_{EOUT}	t_{ZL}	t_{ZH}	t_{LZ}	t_{HZ}	t_{ZLS}	t_{ZHS}	Units
4 mA	STD	0.64	8.06	0.05	1.12	0.46	8.20	7.03	1.26	1.27	8.20	7.027	ns
	-1	0.55	6.85	0.04	.095	0.39	6.98	5.98	1.26	1.27	6.98	5.978	ns
6 mA	STD	0.64	5.03	0.05	1.12	0.46	5.13	4.27	1.42	1.56	5.13	4.267	ns
	-1	0.55	4.28	0.04	0.95	0.39	4.36	3.63	1.42	1.56	4.36	3.63	ns
8 mA	STD	0.64	5.03	0.05	1.12	0.46	5.13	4.27	1.42	1.56	5.13	4.267	ns
	-1	0.55	4.28	0.04	0.95	0.39	4.36	3.63	1.42	1.56	4.36	3.63	ns
12 mA	STD	0.64	3.53	0.05	1.12	0.46	1.74	1.43	3.12	3.60	1.74	1.427	ns
	-1	0.55	3.01	0.04	0.95	0.39	1.74	1.43	2.65	3.06	1.74	1.428	ns
16 mA	STD	0.64	3.53	0.05	1.12	0.46	1.74	1.43	3.12	3.60	1.74	1.427	ns
	-1	0.55	3.01	0.04	0.95	0.39	1.74	1.43	2.65	3.06	1.74	1.428	ns

Notes:

1. Software default selection highlighted in gray.
2. For specific junction temperature and voltage supply levels, refer to [Table 2-5 on page 2-5](#) for derating values.

Table 2-38 • 3.3 V LVTTTL / 3.3 V LVCMOS Low Slew
 Automotive-Case Conditions: $T_J = 135^\circ\text{C}$, Worst-Case VCC = 1.425 V, Worst-Case VCCI = 3.0 V
 Applicable to Standard Plus I/O Banks

Drive Strength	Speed Grade	t_{DOUT}	t_{DP}	t_{DIN}	t_{PY}	t_{EOUT}	t_{ZL}	t_{ZH}	t_{LZ}	t_{HZ}	t_{ZLS}	t_{ZHS}	Units
4 mA	STD	0.64	10.82	0.05	1.12	0.46	11.02	9.42	1.26	1.20	11.02	9.419	ns
	-1	0.55	9.21	0.04	0.95	0.39	9.38	8.01	1.26	1.20	9.38	8.012	ns
6 mA	STD	0.64	7.49	0.05	1.12	0.46	7.63	6.58	1.43	1.48	7.63	6.58	ns
	-1	0.55	6.37	0.04	0.95	0.39	6.49	5.60	1.43	1.49	6.49	5.598	ns
8 mA	STD	0.64	7.49	0.05	1.12	0.46	7.63	6.58	1.43	1.48	7.63	6.58	ns
	-1	0.55	6.37	0.04	0.95	0.39	6.49	5.60	1.43	1.49	6.49	5.598	ns
12 mA	STD	0.64	5.64	0.05	1.12	0.46	5.75	5.04	1.54	1.67	5.75	5.042	ns
	-1	0.55	4.80	0.04	0.95	0.39	4.89	4.29	1.54	1.67	4.89	4.289	ns
16 mA	STD	0.64	5.64	0.05	1.12	0.46	5.75	5.04	1.54	1.67	5.75	5.042	ns
	-1	0.55	4.80	0.04	0.95	0.39	4.89	4.29	1.54	1.67	4.89	4.289	ns

Note: For specific junction temperature and voltage supply levels, refer to [Table 2-5 on page 2-5](#) for derating values.

Table 2-39 • 3.3 V LVTTTL / 3.3 V LVCMOS High Slew
 Automotive-Case Conditions: $T_J = 115^\circ\text{C}$, Worst-Case VCC = 1.425 V, Worst-Case VCCI = 3.0 V
 Applicable to Advanced I/O Banks

Drive Strength	Speed Grade	t_{DOUT}	t_{DP}	t_{DIN}	t_{PY}	t_{EOUT}	t_{ZL}	t_{ZH}	t_{LZ}	t_{HZ}	t_{ZLS}	t_{ZHS}	Units
4 mA	STD	0.63	8.28	0.05	1.10	0.45	8.44	7.13	1.42	1.37	10.85	9.55	ns
	-1	0.53	7.05	0.04	0.94	0.38	7.18	6.06	1.42	1.37	9.23	8.12	ns
6 mA	STD	0.63	5.31	0.05	1.10	0.45	5.41	4.40	1.60	1.68	7.83	6.82	ns
	-1	0.53	4.52	0.04	0.94	0.38	4.60	3.74	1.60	1.68	6.66	5.80	ns
8 mA	STD	0.63	5.31	0.05	1.10	0.45	5.41	4.40	1.60	1.68	7.83	6.82	ns
	-1	0.53	4.52	0.04	0.94	0.38	4.60	3.74	1.60	1.68	6.66	5.80	ns
12 mA	STD	0.63	3.82	0.05	1.10	0.45	3.89	1.51	3.47	1.88	6.31	2.70	ns
	-1	0.53	3.25	0.04	0.94	0.38	3.31	1.51	2.96	1.88	5.37	2.71	ns
16 mA	STD	0.63	3.60	0.05	1.10	0.45	1.78	1.37	3.53	3.98	2.95	2.57	ns
	-1	0.53	3.07	0.04	0.94	0.38	1.78	1.37	3.00	3.38	2.95	2.57	ns
24 mA	STD	0.63	3.33	0.05	1.10	0.45	1.64	1.13	3.60	4.39	2.81	2.33	ns
	-1	0.53	2.83	0.04	0.94	0.38	1.64	1.13	3.06	3.74	2.82	2.33	ns

Notes:

1. Software default selection highlighted in gray.
2. For specific junction temperature and voltage supply levels, refer to [Table 2-5 on page 2-5](#) for derating values.

Table 2-40 • 3.3 V LVTTTL / 3.3 V LVCMOS Low Slew
 Automotive-Case Conditions: $T_J = 115^\circ\text{C}$, Worst-Case VCC = 1.425 V, Worst-Case VCCI = 3.0 V
 Applicable to Advanced I/O Banks

Drive Strength	Speed Grade	t_{DOUT}	t_{DP}	t_{DIN}	t_{PY}	t_{EOUT}	t_{ZL}	t_{ZH}	t_{LZ}	t_{HZ}	t_{ZLS}	t_{ZHS}	Units
4 mA	STD	0.63	11.09	0.05	1.10	0.45	11.30	9.63	1.41	1.29	13.72	12.04	ns
	-1	0.53	9.44	0.04	0.94	0.38	9.61	8.19	1.41	1.29	11.67	10.25	ns
6 mA	STD	0.63	7.87	0.05	1.10	0.45	8.02	6.80	1.59	1.59	10.43	9.22	ns
	-1	0.53	6.69	0.04	0.94	0.38	6.82	5.78	1.59	1.60	8.88	7.84	ns
8 mA	STD	0.63	7.87	0.05	1.10	0.45	8.02	6.80	1.59	1.59	10.43	9.22	ns
	-1	0.53	6.69	0.04	0.94	0.38	6.82	5.78	1.59	1.60	8.88	7.84	ns
12 mA	STD	0.63	6.04	0.05	1.10	0.45	6.15	5.27	1.71	1.79	8.57	7.69	ns
	-1	0.53	5.14	0.04	0.94	0.38	5.23	4.48	1.71	1.79	7.29	6.54	ns
16 mA	STD	0.63	5.63	0.05	1.10	0.45	5.74	4.94	1.74	1.84	8.16	7.36	ns
	-1	0.53	4.79	0.04	0.94	0.38	4.88	4.20	1.74	1.84	6.94	6.26	ns
24 mA	STD	0.63	5.25	0.05	1.10	0.45	5.34	4.92	1.77	2.04	7.76	7.34	ns
	-1	0.53	4.46	0.04	0.94	0.38	4.55	4.18	1.77	2.04	6.60	6.24	ns

Note: For specific junction temperature and voltage supply levels, refer to [Table 2-5 on page 2-5](#) for derating values.

Table 2-41 • 3.3 V LVTTTL / 3.3 V LVCMOS High Slew
 Automotive-Case Conditions: $T_J = 115^\circ\text{C}$, Worst-Case VCC = 1.425 V, Worst-Case VCCI = 3.0 V
 Applicable to Standard Plus I/O Banks

Drive Strength	Speed Grade	t_{DOUT}	t_{DP}	t_{DIN}	t_{PY}	t_{EOUT}	t_{ZL}	t_{ZH}	t_{LZ}	t_{HZ}	t_{ZLS}	t_{ZHS}	Units
4 mA	STD	0.63	7.79	0.05	1.08	0.45	7.94	6.80	1.22	1.23	7.94	6.80	ns
	-1	0.55	6.85	0.04	0.95	0.39	6.98	5.98	1.26	1.27	6.98	5.98	ns
6 mA	STD	0.63	4.87	0.05	1.08	0.45	4.96	4.13	1.38	1.51	4.96	4.13	ns
	-1	0.55	4.28	0.04	0.95	0.39	4.36	3.63	1.42	1.56	4.36	3.63	ns
8 mA	STD	0.63	4.87	0.05	1.08	0.45	4.96	4.13	1.38	1.51	4.96	4.13	ns
	-1	0.55	4.28	0.04	0.95	0.39	4.36	3.63	1.42	1.56	4.36	3.63	ns
12 mA	STD	0.63	3.42	0.05	1.08	0.45	1.69	1.38	3.02	3.48	1.69	1.38	ns
	-1	0.55	3.01	0.04	0.95	0.39	1.74	1.43	2.65	3.06	1.74	1.43	ns
16 mA	STD	0.63	3.42	0.05	1.08	0.45	1.69	1.38	3.02	3.48	1.69	1.38	ns
	-1	0.55	3.01	0.04	0.95	0.39	1.74	1.43	2.65	3.06	1.74	1.43	ns

Notes:

1. Software default selection highlighted in gray.
2. For specific junction temperature and voltage supply levels, refer to [Table 2-5 on page 2-5](#) for derating values.

Table 2-42 • 3.3 V LVTTTL / 3.3 V LVCMOS Low Slew
 Automotive-Case Conditions: $T_J = 115^\circ\text{C}$, Worst-Case VCC = 1.425 V, Worst-Case VCCI = 3.0 V
 Applicable to Standard Plus I/O Banks

Drive Strength	Speed Grade	t_{DOUT}	t_{DP}	t_{DIN}	t_{PY}	t_{EOUT}	t_{ZL}	t_{ZH}	t_{LZ}	t_{HZ}	t_{ZLS}	t_{ZHS}	Units
4 mA	STD	0.63	10.47	0.05	1.08	0.45	10.66	9.11	1.22	1.16	10.66	9.11	ns
	-1	0.55	9.21	0.04	0.95	0.39	9.38	8.01	1.26	1.20	9.38	8.01	ns
6 mA	STD	0.63	7.25	0.05	1.08	0.45	7.38	6.37	1.38	1.44	7.38	6.37	ns
	-1	0.55	6.37	0.04	0.95	0.39	6.49	5.60	1.43	1.49	6.49	5.60	ns
8 mA	STD	0.63	7.25	0.05	1.08	0.45	7.38	6.37	1.38	1.44	7.38	6.37	ns
	-1	0.55	6.37	0.04	0.95	0.39	6.49	5.60	1.43	1.49	6.49	5.60	ns
12 mA	STD	0.63	5.46	0.05	1.08	0.45	5.56	4.88	1.49	1.61	5.56	4.88	ns
	-1	0.55	4.80	0.04	0.95	0.39	4.89	4.29	1.54	1.67	4.89	4.29	ns
16 mA	STD	0.63	5.46	0.05	1.08	0.45	5.56	4.88	1.49	1.61	5.56	4.88	ns
	-1	0.55	4.80	0.04	0.95	0.39	4.89	4.29	1.54	1.67	4.89	4.29	ns

Note: For specific junction temperature and voltage supply levels, refer to [Table 2-5 on page 2-5](#) for derating values.

2.5 V LVCMOS

Low-Voltage CMOS for 2.5 V is an extension of the LVCMOS standard (JESD8-5) used for general-purpose 2.5 V applications.

Table 2-43 • Minimum and Maximum DC Input and Output Levels
Applicable to Advanced I/O Banks

2.5 V LVCMOS Drive Strength	VIL		VIH		VOL	VOH	IOL	IOH	IOSL	IOSH	IIL	IIH
	Min. V	Max. V	Min. V	Max. V	Max. V	Min. V	mA	mA	Max. mA ¹	Max. mA ¹	μA ²	μA ²
2 mA	-0.3	0.7	1.7	3.6	0.7	1.7	2	2	18	16	10	10
6 mA	-0.3	0.7	1.7	3.6	0.7	1.7	6	6	37	32	10	10
12 mA	-0.3	0.7	1.7	3.6	0.7	1.7	12	12	74	65	10	10
16 mA	-0.3	0.7	1.7	3.6	0.7	1.7	16	16	87	83	10	10
24 mA	-0.3	0.7	1.7	3.6	0.7	1.7	24	24	124	169	10	10

Notes:

1. Currents are measured at high temperature (100°C junction temperature) and maximum voltage.
2. Currents are measured at 125°C junction temperature.
3. Software default selection highlighted in gray.

Table 2-44 • Minimum and Maximum DC Input and Output Levels
Applicable to Standard Plus I/O Banks

2.5 V LVCMOS Drive Strength	VIL		VIH		VOL	VOH	IOL	IOH	IOSL	IOSH	IIL	IIH
	Min. V	Max. V	Min. V	Max. V	Max. V	Min. V	mA	mA	Max., mA ¹	Max., mA ¹	μA ²	μA ²
2 mA	-0.3	0.7	1.7	3.6	0.7	1.7	2	2	18	16	10	10
6 mA	-0.3	0.7	1.7	3.6	0.7	1.7	6	6	37	32	10	10
12 mA	-0.3	0.7	1.7	3.6	0.7	1.7	12	12	74	65	10	10

Notes:

1. Currents are measured at high temperature (100°C junction temperature) and maximum voltage.
2. Currents are measured at 125°C junction temperature.
3. Software default selection highlighted in gray.

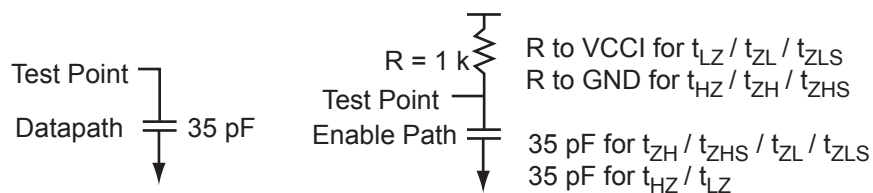

Figure 2-8 • AC Loading

Table 2-45 • AC Waveforms, Measuring Points, and Capacitive Loads

Input Low (V)	Input High (V)	Measuring Point* (V)	C _{LOAD} (pF)
0	2.5	1.2	35

Note: *Measuring point = V_{trip}. See Table 2-18 on page 2-17 for a complete table of trip points.

Timing Characteristics
Table 2-46 • 2.5 V LVCMOS High Slew
Automotive-Case Conditions: $T_J = 135^\circ\text{C}$, Worst-Case VCC = 1.425 V, Worst-Case VCCI = 2.3 V
Applicable to Advanced I/O Banks

Drive Strength	Speed Grade	t_{DOUT}	t_{DP}	t_{DIN}	t_{PY}	t_{EOUT}	t_{ZL}	t_{ZH}	t_{LZ}	t_{HZ}	t_{ZLS}	t_{ZHS}	Units
2 mA	STD	0.64	9.69	0.05	1.45	0.46	8.76	9.69	1.48	1.25	11.26	12.187	ns
	-1	0.55	8.24	0.04	1.23	0.39	7.45	8.24	1.48	1.25	9.58	10.367	ns
6 mA	STD	0.64	5.78	0.05	1.45	0.46	5.63	5.78	1.68	1.62	8.13	8.277	ns
	-1	0.55	4.91	0.04	1.23	0.39	4.79	4.91	1.69	1.63	6.92	7.04	ns
12 mA	STD	0.64	3.98	0.05	1.45	0.46	4.05	3.84	1.82	1.86	6.55	6.338	ns
	-1	0.55	3.39	0.04	1.23	0.39	3.45	3.27	1.83	1.86	5.58	5.392	ns
16 mA	STD	0.64	3.75	0.05	1.45	0.46	1.85	1.69	3.76	3.97	3.06	2.926	ns
	-1	0.55	3.19	0.04	1.23	0.39	1.85	1.69	3.20	3.38	3.06	2.929	ns
24 mA	STD	0.64	3.45	0.05	1.45	0.46	1.70	1.35	3.84	4.47	2.92	2.585	ns
	-1	0.55	2.94	0.04	1.23	0.39	1.71	1.35	3.27	3.80	2.92	2.586	ns

Notes:

1. Software default selection highlighted in gray.
2. For specific junction temperature and voltage supply levels, refer to [Table 2-5 on page 2-5](#) for derating values.

Table 2-47 • 2.5 V LVCMOS Low Slew
Automotive-Case Conditions: $T_J = 135^\circ\text{C}$, Worst-Case VCC = 1.425 V, Worst-Case VCCI = 2.3 V
Applicable to Advanced I/O Banks

Drive Strength	Speed Grade	t_{DOUT}	t_{DP}	t_{DIN}	t_{PY}	t_{EOUT}	t_{ZL}	t_{ZH}	t_{LZ}	t_{HZ}	t_{ZLS}	t_{ZHS}	Units
2 mA	STD	0.64	12.12	0.05	1.45	0.46	12.54	12.74	1.48	1.19	15.04	15.243	ns
	-1	0.55	10.31	0.04	1.23	0.39	10.67	10.84	1.48	1.20	12.80	12.966	ns
6 mA	STD	0.64	8.24	0.05	1.45	0.46	9.07	8.74	1.68	1.57	11.57	11.237	ns
	-1	0.55	7.01	0.04	1.23	0.39	7.71	7.43	1.69	1.57	9.84	9.559	ns
12 mA	STD	0.64	6.91	0.05	1.45	0.46	7.04	6.62	1.82	1.80	9.54	9.117	ns
	-1	0.55	5.88	0.04	1.23	0.39	5.99	5.63	1.83	1.80	8.11	7.756	ns
16 mA	STD	0.64	6.44	0.05	1.45	0.46	6.56	6.18	1.86	1.86	9.06	8.678	ns
	-1	0.55	5.48	0.04	1.23	0.39	5.58	5.26	1.86	1.86	7.71	7.382	ns
24 mA	STD	0.64	6.16	0.05	1.45	0.46	6.15	6.16	1.90	2.10	8.65	8.657	ns
	-1	0.55	5.24	0.04	1.23	0.39	5.23	5.24	1.90	2.10	7.36	7.364	ns

Note: For specific junction temperature and voltage supply levels, refer to [Table 2-5 on page 2-5](#) for derating values.

Table 2-48 • 2.5 V LVC MOS High Slew

Automotive-Case Conditions: $T_J = 135^\circ\text{C}$, Worst-Case VCC = 1.425 V, Worst-Case VCCI = 2.3 V
Applicable to Standard Plus I/O Banks

Drive Strength	Speed Grade	t_{DOUT}	t_{DP}	t_{DIN}	t_{PY}	t_{EOUT}	t_{ZL}	t_{ZH}	t_{LZ}	t_{HZ}	t_{ZLS}	t_{ZHS}	Units
2 mA	STD	0.64	9.26	0.05	1.45	0.46	8.28	9.26	1.24	1.12	10.78	11.756	ns
	-1	0.55	7.87	0.04	1.23	0.39	7.05	7.87	1.24	1.13	9.17	10	ns
6 mA	STD	0.64	5.43	0.05	1.45	0.46	5.19	5.43	1.43	1.47	7.69	7.926	ns
	-1	0.55	4.62	0.04	1.23	0.39	4.42	4.62	1.43	1.47	6.55	6.743	ns
12 mA	STD	0.64	3.59	0.05	1.45	0.46	3.65	3.51	1.56	1.69	6.15	6.012	ns
	-1	0.55	3.05	0.04	1.23	0.39	3.11	2.99	1.56	1.69	5.23	5.114	ns

Notes:

1. Software default selection highlighted in gray.
2. For specific junction temperature and voltage supply levels, refer to [Table 2-5 on page 2-5](#) for derating values.

Table 2-49 • 2.5 V LVC MOS Low Slew

Automotive-Case Conditions: $T_J = 135^\circ\text{C}$, Worst-Case VCC = 1.425 V, Worst-Case VCCI = 2.3 V
Applicable to Standard Plus I/O Banks

Drive Strength	Speed Grade	t_{DOUT}	t_{DP}	t_{DIN}	t_{PY}	t_{EOUT}	t_{ZL}	t_{ZH}	t_{LZ}	t_{HZ}	t_{ZLS}	t_{ZHS}	Units
2 mA	STD	0.64	12.12	0.05	1.45	0.46	11.89	12.12	1.25	1.08	14.39	14.622	ns
	-1	0.55	10.31	0.04	1.23	0.39	10.12	10.31	1.25	1.08	12.24	12.438	ns
6 mA	STD	0.64	8.24	0.05	1.45	0.46	8.39	8.23	1.43	1.42	10.89	10.73	ns
	-1	0.55	7.01	0.04	1.23	0.39	7.14	7.00	1.43	1.42	9.26	9.128	ns
12 mA	STD	0.64	6.30	0.05	1.45	0.46	6.41	6.16	1.56	1.63	8.91	8.656	ns
	-1	0.55	5.35	0.04	1.23	0.39	5.45	5.24	1.56	1.63	7.58	7.364	ns

Note: For specific junction temperature and voltage supply levels, refer to [Table 2-5 on page 2-5](#) for derating values.

Table 2-50 • 2.5 V LVC MOS High Slew

 Automotive-Case Conditions: $T_J = 115^\circ\text{C}$, Worst-Case VCC = 1.425 V, Worst-Case VCCI = 2.3 V
 Applicable to Advanced I/O Banks

Drive Strength	Speed Grade	t_{DOUT}	t_{DP}	t_{DIN}	t_{PY}	t_{EOUT}	t_{ZL}	t_{ZH}	t_{LZ}	t_{HZ}	t_{ZLS}	t_{ZHS}	Units
2 mA	STD	0.63	9.37	0.05	1.40	0.45	8.47	9.37	1.43	1.21	10.89	11.79	ns
	-1	0.53	7.97	0.04	1.19	0.38	7.21	7.97	1.43	1.21	9.27	10.03	ns
6 mA	STD	0.63	5.59	0.05	1.40	0.45	5.45	5.59	1.63	1.57	7.87	8.01	ns
	-1	0.53	4.75	0.04	1.19	0.38	4.63	4.75	1.63	1.57	6.69	6.81	ns
12 mA	STD	0.63	3.85	0.05	1.40	0.45	3.92	3.71	1.77	1.80	6.34	6.13	ns
	-1	0.53	3.28	0.04	1.19	0.38	3.34	3.16	1.77	1.80	5.39	5.22	ns
16 mA	STD	0.63	3.63	0.05	1.40	0.45	1.79	1.64	3.64	3.84	2.96	2.83	ns
	-1	0.53	3.08	0.04	1.19	0.38	1.79	1.64	3.09	3.27	2.96	2.83	ns
24 mA	STD	0.63	3.34	0.05	1.40	0.45	1.65	1.31	3.72	4.32	2.82	2.50	ns
	-1	0.53	2.84	0.04	1.19	0.38	1.65	1.31	3.16	3.68	2.82	2.50	ns

Notes:

1. Software default selection highlighted in gray.
2. For specific junction temperature and voltage supply levels, refer to [Table 2-5 on page 2-5](#) for derating values.

Table 2-51 • 2.5 V LVC MOS Low Slew

 Automotive-Case Conditions: $T_J = 115^\circ\text{C}$, Worst-Case VCC = 1.425 V, Worst-Case VCCI = 2.3 V
 Applicable to Advanced I/O Banks

Drive Strength	Speed Grade	t_{DOUT}	t_{DP}	t_{DIN}	t_{PY}	t_{EOUT}	t_{ZL}	t_{ZH}	t_{LZ}	t_{HZ}	t_{ZLS}	t_{ZHS}	Units
2 mA	STD	0.63	11.73	0.05	1.40	0.45	12.14	12.33	1.43	1.16	14.55	14.75	ns
	-1	0.53	9.98	0.04	1.19	0.38	10.32	10.49	1.43	1.16	12.38	12.55	ns
6 mA	STD	0.63	7.97	0.05	1.40	0.45	8.77	8.45	1.63	1.51	11.19	10.87	ns
	-1	0.53	6.78	0.04	1.19	0.38	7.46	7.19	1.63	1.52	9.52	9.25	ns
12 mA	STD	0.63	6.68	0.05	1.40	0.45	6.81	6.40	1.77	1.74	9.23	8.82	ns
	-1	0.53	5.69	0.04	1.19	0.38	5.79	5.45	1.77	1.74	7.85	7.50	ns
16 mA	STD	0.63	6.24	0.05	1.40	0.45	6.35	5.98	1.80	1.80	8.77	8.40	ns
	-1	0.53	5.30	0.04	1.19	0.38	5.40	5.08	1.80	1.80	7.46	7.14	ns
24 mA	STD	0.63	5.96	0.05	1.40	0.45	5.95	5.96	1.84	2.03	8.37	8.38	ns
	-1	0.53	5.07	0.04	1.19	0.38	5.06	5.07	1.84	2.03	7.12	7.12	ns

Note: For specific junction temperature and voltage supply levels, refer to [Table 2-5 on page 2-5](#) for derating values.

Table 2-52 • 2.5 V LVC MOS High Slew

Automotive-Case Conditions: $T_J = 115^\circ\text{C}$, Worst-Case VCC = 1.425 V, Worst-Case VCCI = 2.3 V
Applicable to Standard Plus I/O Banks

Drive Strength	Speed Grade	t_{DOUT}	t_{DP}	t_{DIN}	t_{PY}	t_{EOUT}	t_{ZL}	t_{ZH}	t_{LZ}	t_{HZ}	t_{ZLS}	t_{ZHS}	Units
2 mA	STD	0.63	8.95	0.05	1.40	0.45	8.01	8.95	1.20	1.09	10.43	11.37	ns
	-1	0.53	7.62	0.04	1.19	0.38	6.82	7.62	1.20	1.09	8.87	9.68	ns
6 mA	STD	0.63	5.25	0.05	1.40	0.45	5.03	5.25	1.38	1.42	7.44	7.67	ns
	-1	0.53	4.47	0.04	1.19	0.38	4.27	4.47	1.38	1.42	6.33	6.52	ns
12 mA	STD	0.63	3.47	0.05	1.40	0.45	3.53	3.40	1.51	1.63	5.95	5.82	ns
	-1	0.53	2.95	0.04	1.19	0.38	3.01	2.89	1.51	1.63	5.06	4.95	ns

Notes:

1. Software default selection highlighted in gray.
2. For specific junction temperature and voltage supply levels, refer to [Table 2-5 on page 2-5](#) for derating values.

Table 2-53 • 2.5 V LVC MOS Low Slew

Automotive-Case Conditions: $T_J = 115^\circ\text{C}$, Worst-Case VCC = 1.425 V, Worst-Case VCCI = 2.3 V
Applicable to Standard Plus I/O Banks

Drive Strength	Speed Grade	t_{DOUT}	t_{DP}	t_{DIN}	t_{PY}	t_{EOUT}	t_{ZL}	t_{ZH}	t_{LZ}	t_{HZ}	t_{ZLS}	t_{ZHS}	Units
2 mA	STD	0.63	11.73	0.05	1.40	0.45	11.51	11.73	1.21	1.04	13.93	14.15	ns
	-1	0.53	9.98	0.04	1.19	0.38	9.79	9.98	1.21	1.04	11.85	12.03	ns
6 mA	STD	0.63	7.97	0.05	1.40	0.45	8.12	7.96	1.38	1.37	10.54	10.38	ns
	-1	0.53	6.78	0.04	1.19	0.38	6.91	6.77	1.39	1.37	8.96	8.83	ns
12 mA	STD	0.63	6.09	0.05	1.40	0.45	6.20	5.96	1.51	1.58	8.62	8.38	ns
	-1	0.53	5.18	0.04	1.19	0.38	5.28	5.07	1.51	1.58	7.33	7.12	ns

Note: For specific junction temperature and voltage supply levels, refer to [Table 2-5 on page 2-5](#) for derating values.

1.8 V LVCMOS

Low-voltage CMOS for 1.8 V is an extension of the LVCMOS standard (JESD8-5) used for general-purpose 1.8 V applications. It uses a 1.8 V input buffer and a push-pull output buffer.

Table 2-54 • Minimum and Maximum DC Input and Output Levels
Applicable to Advanced I/O Banks

1.8 V LVCMOS	VIL		VIH		VOL	VOH	I _{OL}	I _{OH}	I _{OSL}	I _{OSH}	I _{IL}	I _{IH}
	Min. V	Max. V	Min. V	Max. V	Max. V	Min. V	mA	mA	Max. mA ¹	Max. mA ¹	μA ²	μA ²
2 mA	-0.3	0.35 * V _{CCI}	0.65 * V _{CCI}	3.6	0.45	V _{CCI} - 0.45	2	2	11	9	10	10
4 mA	-0.3	0.35 * V _{CCI}	0.65 * V _{CCI}	3.6	0.45	V _{CCI} - 0.45	4	4	22	17	10	10
6 mA	-0.3	0.35 * V _{CCI}	0.65 * V _{CCI}	3.6	0.45	V _{CCI} - 0.45	6	6	44	35	10	10
8 mA	-0.3	0.35 * V _{CCI}	0.65 * V _{CCI}	3.6	0.45	V _{CCI} - 0.45	8	8	51	45	10	10
12 mA	-0.3	0.35 * V _{CCI}	0.65 * V _{CCI}	3.6	0.45	V _{CCI} - 0.45	12	12	74	91	10	10
16 mA	-0.3	0.35 * V _{CCI}	0.65 * V _{CCI}	3.6	0.45	V _{CCI} - 0.45	16	16	74	91	10	10

Notes:

1. Currents are measured at high temperature (100°C junction temperature) and maximum voltage.
2. Currents are measured at 125°C junction temperature.
3. Software default selection highlighted in gray.

Table 2-55 • Minimum and Maximum DC Input and Output Levels
Applicable to Standard Plus I/O I/O Banks

1.8 V LVCMOS	VIL		VIH		VOL	VOH	I _{OL}	I _{OH}	I _{OSL}	I _{OSH}	I _{IL}	I _{IH}
	Min. V	Max. V	Min. V	Max. V	Max. V	Min. V	mA	mA	Max. mA ¹	Max. mA ¹	μA ²	μA ²
2 mA	-0.3	0.35 * V _{CCI}	0.65 * V _{CCI}	3.6	0.45	V _{CCI} - 0.45	2	2	11	9	10	10
4 mA	-0.3	0.35 * V _{CCI}	0.65 * V _{CCI}	3.6	0.45	V _{CCI} - 0.45	4	4	22	17	10	10
6 mA	-0.3	0.35 * V _{CCI}	0.65 * V _{CCI}	3.6	0.45	V _{CCI} - 0.45	6	6	44	35	10	10
8 mA	-0.3	0.35 * V _{CCI}	0.65 * V _{CCI}	3.6	0.45	V _{CCI} - 0.45	8	8	44	35	10	10

Notes:

1. Currents are measured at high temperature (100°C junction temperature) and maximum voltage.
2. Currents are measured at 125°C junction temperature.
3. Software default selection highlighted in gray.

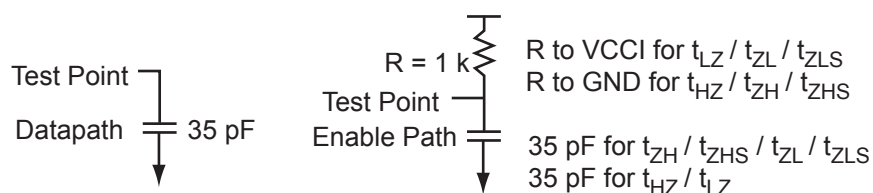

Figure 2-9 • AC Loading

Table 2-56 • AC Waveforms, Measuring Points, and Capacitive Loads

Input Low (V)	Input High (V)	Measuring Point* (V)	C _{LOAD} (pF)
0	1.8	0.9	35

Note: *Measuring point = V_{trip}. See Table 2-18 on page 2-17 for a complete table of trip points.

Timing Characteristics

Table 2-57 • 1.8 V LVC MOS High Slew

Automotive-Case Conditions: $T_J = 135^\circ\text{C}$, Worst-Case $V_{CC} = 1.425\text{ V}$, Worst-Case $V_{CCI} = 2.3\text{ V}$
 Applicable to Advanced I/O Banks

Drive Strength	Speed Grade	t_{DOUT}	t_{DP}	t_{DIN}	t_{PY}	t_{EOUT}	t_{ZL}	t_{ZH}	t_{LZ}	t_{HZ}	t_{ZLS}	t_{ZHS}	Units
2 mA	STD	0.64	13.26	0.05	1.36	0.46	10.22	13.26	1.53	0.90	12.72	15.764	ns
	-1	0.55	11.28	0.04	1.16	0.39	8.69	11.28	1.53	0.90	10.82	13.41	ns
4 mA	STD	0.64	7.73	0.05	1.36	0.46	6.55	7.73	1.78	1.54	9.05	10.232	ns
	-1	0.55	6.58	0.04	1.16	0.39	5.58	6.58	1.78	1.54	7.70	8.704	ns
6 mA	STD	0.64	4.97	0.05	1.36	0.46	4.67	4.97	1.95	1.83	7.17	7.472	ns
	-1	0.55	4.23	0.04	1.16	0.39	3.98	4.23	1.95	1.83	6.10	6.356	ns
8 mA	STD	0.64	4.39	0.05	1.36	0.46	4.39	4.39	1.99	1.91	6.89	6.888	ns
	-1	0.55	3.73	0.04	1.16	0.39	3.74	3.73	1.99	1.91	5.86	5.859	ns
12 mA	STD	0.64	3.95	0.05	1.36	0.46	1.95	1.68	4.14	4.56	3.16	2.915	ns
	-1	0.55	3.36	0.04	1.16	0.39	1.95	1.68	3.52	3.88	3.16	2.918	ns
16 mA	STD	0.64	3.95	0.05	1.36	0.46	1.95	1.68	4.14	4.56	3.16	2.915	ns
	-1	0.55	3.36	0.04	1.16	0.39	1.95	1.68	3.52	3.88	3.16	2.918	ns

Notes:

1. Software default selection highlighted in gray.
2. For specific junction temperature and voltage supply levels, refer to [Table 2-5 on page 2-5](#) for derating values.

Table 2-58 • 1.8 V LVC MOS Low Slew

Automotive-Case Conditions: $T_J = 135^\circ\text{C}$, Worst-Case VCC = 1.425 V, Worst-Case VCCI = 2.3 V
 Applicable to Advanced I/O Banks

Drive Strength	Speed Grade	t_{DOUT}	t_{DP}	t_{DIN}	t_{PY}	t_{EOUT}	t_{ZL}	t_{ZH}	t_{LZ}	t_{HZ}	t_{ZLS}	t_{ZHS}	Units
2 mA	STD	0.64	17.36	0.05	1.45	0.46	15.78	17.36	1.53	0.87	18.28	19.864	ns
	-1	0.55	14.77	0.04	1.23	0.39	13.42	14.77	1.54	0.87	15.55	16.897	ns
4 mA	STD	0.64	11.71	0.05	1.45	0.46	11.64	11.71	1.78	1.48	14.14	14.214	ns
	-1	0.55	9.96	0.04	1.23	0.39	9.90	9.96	1.78	1.48	12.03	12.091	ns
6 mA	STD	0.64	9.00	0.05	1.45	0.46	9.17	8.77	1.95	1.77	11.67	11.267	ns
	-1	0.55	7.66	0.04	1.23	0.39	7.80	7.46	1.95	1.77	9.92	9.585	ns
8 mA	STD	0.64	8.39	0.05	1.45	0.46	8.54	8.16	1.99	1.85	11.04	10.66	ns
	-1	0.55	7.14	0.04	1.23	0.39	7.27	6.94	1.99	1.85	9.40	9.068	ns
12 mA	STD	0.64	8.15	0.05	1.45	0.46	8.09	8.15	2.05	2.14	10.59	10.654	ns
	-1	0.55	6.94	0.04	1.23	0.39	6.88	6.94	2.05	2.14	9.01	9.063	ns
16 mA	STD	0.64	8.15	0.05	1.45	0.46	8.09	8.15	2.05	2.14	10.59	10.654	ns
	-1	0.55	6.94	0.04	1.23	0.39	6.88	6.94	2.05	2.14	9.01	9.063	ns

Note: For specific junction temperature and voltage supply levels, refer to Table 2-5 on page 2-5 for derating values.

Table 2-59 • 1.8 V LVC MOS High Slew

Automotive-Case Conditions: $T_J = 135^\circ\text{C}$, Worst-Case VCC = 1.425 V, Worst-Case VCCI = 2.3 V
 Applicable to Standard Plus I/O Banks

Drive Strength	Speed Grade	t_{DOUT}	t_{DP}	t_{DIN}	t_{PY}	t_{EOUT}	t_{ZL}	t_{ZH}	t_{LZ}	t_{HZ}	t_{ZLS}	t_{ZHS}	Units
2 mA	STD	0.64	13.26	0.05	1.36	0.46	9.75	12.67	1.24	0.82	12.26	15.17	ns
	-1	0.55	11.28	0.04	1.16	0.39	8.30	10.78	1.24	0.83	10.43	12.905	ns
4 mA	STD	0.64	7.73	0.05	1.36	0.46	6.13	7.25	1.46	1.41	8.63	9.749	ns
	-1	0.55	6.58	0.04	1.16	0.39	5.21	6.17	1.46	1.41	7.34	8.293	ns
6 mA	STD	0.64	4.97	0.05	1.36	0.46	4.29	4.54	1.62	1.68	6.79	7.039	ns
	-1	0.55	4.23	0.04	1.16	0.39	3.65	3.86	1.62	1.68	5.78	5.987	ns
8 mA	STD	0.64	4.39	0.05	1.36	0.46	4.29	4.54	1.62	1.68	6.79	7.039	ns
	-1	0.55	3.73	0.04	1.16	0.39	3.65	3.86	1.62	1.68	5.78	5.987	ns

Notes:

1. Software default selection highlighted in gray.
2. For specific junction temperature and voltage supply levels, refer to Table 2-5 on page 2-5 for derating values.

Table 2-60 • 1.8 V LVC MOS Low Slew

Automotive-Case Conditions: $T_J = 135^\circ\text{C}$, Worst-Case VCC = 1.425 V, Worst-Case VCCI = 2.3 V
 Applicable to Standard Plus I/O Banks

Drive Strength	Speed Grade	t_{DOUT}	t_{DP}	t_{DIN}	t_{PY}	t_{EOUT}	t_{ZL}	t_{ZH}	t_{LZ}	t_{HZ}	t_{ZLS}	t_{ZHS}	Units
2 mA	STD	0.64	17.36	0.05	1.45	0.46	15.09	16.55	1.24	0.79	17.59	19.052	ns
	-1	0.55	14.77	0.04	1.23	0.39	12.84	14.08	1.24	0.79	14.96	16.207	ns
4 mA	STD	0.64	11.71	0.05	1.45	0.46	10.88	11.07	1.47	1.35	13.38	13.567	ns
	-1	0.55	9.96	0.04	1.23	0.39	9.26	9.41	1.47	1.35	11.38	11.541	ns
6 mA	STD	0.64	9.00	0.05	1.45	0.46	8.47	8.18	1.62	1.62	10.97	10.685	ns
	-1	0.55	7.66	0.04	1.23	0.39	7.21	6.96	1.62	1.62	9.33	9.089	ns
8 mA	STD	0.64	8.39	0.05	1.45	0.46	8.47	8.18	1.62	1.62	10.97	10.685	ns
	-1	0.55	7.14	0.04	1.23	0.39	7.21	6.96	1.62	1.62	9.33	9.089	ns

Note: For specific junction temperature and voltage supply levels, refer to Table 2-5 on page 2-5 for derating values.

Table 2-61 • 1.8 V LVC MOS High Slew

Automotive-Case Conditions: $T_J = 115^\circ\text{C}$, Worst-Case VCC = 1.425 V, Worst-Case VCCI = 2.3 V
 Applicable to Advanced I/O Banks

Drive Strength	Speed Grade	t_{DOUT}	t_{DP}	t_{DIN}	t_{PY}	t_{EOUT}	t_{ZL}	t_{ZH}	t_{LZ}	t_{HZ}	t_{ZLS}	t_{ZHS}	Units
2 mA	STD	0.63	12.83	0.05	1.32	0.45	9.88	12.83	1.48	0.87	12.30	15.25	ns
	-1	0.53	10.92	0.04	1.12	0.38	8.41	10.92	1.48	0.87	10.46	12.97	ns
4 mA	STD	0.63	7.48	0.05	1.32	0.45	6.34	7.48	1.72	1.49	8.76	9.90	ns
	-1	0.53	6.36	0.04	1.12	0.38	5.39	6.36	1.72	1.49	7.45	8.42	ns
6 mA	STD	0.63	4.81	0.05	1.32	0.45	4.52	4.81	1.89	1.77	6.94	7.23	ns
	-1	0.53	4.09	0.04	1.12	0.38	3.85	4.09	1.89	1.77	5.90	6.15	ns
8 mA	STD	0.63	4.25	0.05	1.32	0.45	4.25	4.25	1.92	1.85	6.67	6.66	ns
	-1	0.53	3.61	0.04	1.12	0.38	3.61	3.61	1.93	1.85	5.67	5.67	ns
12 mA	STD	0.63	3.82	0.05	1.32	0.45	1.89	1.63	4.00	4.41	3.06	2.82	ns
	-1	0.53	3.25	0.04	1.12	0.38	1.89	1.63	3.41	3.75	3.06	2.82	ns
16 mA	STD	0.63	3.82	0.05	1.32	0.45	1.89	1.63	4.00	4.41	3.06	2.82	ns
	-1	0.53	3.25	0.04	1.12	0.38	1.89	1.63	3.41	3.75	3.06	2.82	ns

Notes:

1. Software default selection highlighted in gray.
2. For specific junction temperature and voltage supply levels, refer to Table 2-5 on page 2-5 for derating values.

Table 2-62 • 1.8 V LVC MOS Low Slew

Automotive-Case Conditions: $T_J = 115^\circ\text{C}$, Worst-Case VCC = 1.425 V, Worst-Case VCCI = 2.3 V
 Applicable to Advanced I/O Banks

Drive Strength	Speed Grade	t_{DOUT}	t_{DP}	t_{DIN}	t_{PY}	t_{EOUT}	t_{ZL}	t_{ZH}	t_{LZ}	t_{HZ}	t_{ZLS}	t_{ZHS}	Units
2 mA	STD	0.63	16.80	0.05	1.40	0.45	15.27	16.80	1.48	0.84	17.69	19.22	ns
	-1	0.53	14.29	0.04	1.19	0.38	12.99	14.29	1.49	0.84	15.05	16.35	ns
4 mA	STD	0.63	11.33	0.05	1.40	0.45	11.26	11.33	1.73	1.43	13.68	13.75	ns
	-1	0.53	9.64	0.04	1.19	0.38	9.58	9.64	1.73	1.43	11.64	11.70	ns
6 mA	STD	0.63	8.71	0.05	1.40	0.45	8.87	8.48	1.89	1.72	11.29	10.90	ns
	-1	0.53	7.41	0.04	1.19	0.38	7.54	7.22	1.89	1.72	9.60	9.27	ns
8 mA	STD	0.63	8.12	0.05	1.40	0.45	8.27	7.89	1.93	1.79	10.69	10.31	ns
	-1	0.53	6.90	0.04	1.19	0.38	7.03	6.72	1.93	1.79	9.09	8.77	ns
12 mA	STD	0.63	7.89	0.05	1.40	0.45	7.83	7.89	1.98	2.07	10.25	10.31	ns
	-1	0.53	6.71	0.04	1.19	0.38	6.66	6.71	1.98	2.07	8.72	8.77	ns
16 mA	STD	0.63	7.89	0.05	1.40	0.45	7.83	7.89	1.98	2.07	10.25	10.31	ns
	-1	0.53	6.71	0.04	1.19	0.38	6.66	6.71	1.98	2.07	8.72	8.77	ns

Note: For specific junction temperature and voltage supply levels, refer to Table 2-5 on page 2-5 for derating values.

Table 2-63 • 1.8 V LVC MOS High Slew

Automotive-Case Conditions: $T_J = 115^\circ\text{C}$, Worst-Case VCC = 1.425 V, Worst-Case VCCI = 2.3 V
 Applicable to Standard Plus I/O Banks

Drive Strength	Speed Grade	t_{DOUT}	t_{DP}	t_{DIN}	t_{PY}	t_{EOUT}	t_{ZL}	t_{ZH}	t_{LZ}	t_{HZ}	t_{ZLS}	t_{ZHS}	Units
2 mA	STD	0.63	12.83	0.05	1.32	0.45	9.44	12.26	1.20	0.80	11.86	14.68	ns
	-1	0.53	10.92	0.04	1.12	0.38	8.03	10.43	1.20	0.80	10.09	12.49	ns
4 mA	STD	0.63	7.48	0.05	1.32	0.45	5.93	7.01	1.41	1.36	8.35	9.43	ns
	-1	0.53	6.36	0.04	1.12	0.38	5.04	5.97	1.42	1.37	7.10	8.02	ns
6 mA	STD	0.63	4.81	0.05	1.32	0.45	4.15	4.39	1.57	1.63	6.57	6.81	ns
	-1	0.53	4.09	0.04	1.12	0.38	3.53	3.74	1.57	1.63	5.59	5.79	ns
8 mA	STD	0.63	4.25	0.05	1.32	0.45	4.15	4.39	1.57	1.63	6.57	6.81	ns
	-1	0.53	3.61	0.04	1.12	0.38	3.53	3.74	1.57	1.63	5.59	5.79	ns

Notes:

1. Software default selection highlighted in gray.
2. For specific junction temperature and voltage supply levels, refer to Table 2-5 on page 2-5 for derating values.

Table 2-64 • 1.8 V LVCMOS Low Slew

Automotive-Case Conditions: $T_J = 115^\circ\text{C}$, Worst-Case $V_{CC} = 1.425\text{ V}$, Worst-Case $V_{CCI} = 2.3\text{ V}$
 Applicable to Standard Plus I/O Banks

Drive Strength	Speed Grade	t_{DOUT}	t_{DP}	t_{DIN}	t_{PY}	t_{EOUT}	t_{ZL}	t_{ZH}	t_{LZ}	t_{HZ}	t_{ZLS}	t_{ZHS}	Units
2 mA	STD	0.63	16.80	0.05	1.40	0.45	14.60	16.01	1.20	0.77	17.02	18.43	ns
	-1	0.53	14.29	0.04	1.19	0.38	12.42	13.62	1.20	0.77	14.48	15.68	ns
4 mA	STD	0.63	11.33	0.05	1.40	0.45	10.53	10.71	1.42	1.31	12.95	13.13	ns
	-1	0.53	9.64	0.04	1.19	0.38	8.96	9.11	1.42	1.31	11.01	11.17	ns
6 mA	STD	0.63	8.71	0.05	1.40	0.45	8.19	7.92	1.57	1.57	10.61	10.34	ns
	-1	0.53	7.41	0.04	1.19	0.38	6.97	6.74	1.57	1.57	9.03	8.79	ns
8 mA	STD	0.63	8.12	0.05	1.40	0.45	8.19	7.92	1.57	1.57	10.61	10.34	ns
	-1	0.53	6.90	0.04	1.19	0.38	6.97	6.74	1.57	1.57	9.03	8.79	ns

Note: For specific junction temperature and voltage supply levels, refer to Table 2-5 on page 2-5 for derating values.

1.5 V LVCMOS (JESD8-11)

Low-Voltage CMOS for 1.5 V is an extension of the LVCMOS standard (JESD8-5) used for general-purpose 1.5 V applications. It uses a 1.5 V input buffer and a push-pull output buffer.

Table 2-65 • Minimum and Maximum DC Input and Output Levels
 Applicable to Advanced I/O Banks

1.5 V LVCMOS	VIL		VIH		VOL	VOH	I_{OL}	I_{OH}	I_{OSL}	I_{OSH}	I_{IL}	I_{IH}
	Min. V	Max. V	Min. V	Max. V	Max. V	Min. V	mA	mA	Max. mA ¹	Max. mA ¹	μA^2	μA^2
2 mA	-0.3	0.30 * V_{CCI}	0.7 * V_{CCI}	3.6	0.25 * V_{CCI}	0.75 * V_{CCI}	2	2	16	13	10	10
4 mA	-0.3	0.30 * V_{CCI}	0.7 * V_{CCI}	3.6	0.25 * V_{CCI}	0.75 * V_{CCI}	4	4	33	25	10	10
6 mA	-0.3	0.30 * V_{CCI}	0.7 * V_{CCI}	3.6	0.25 * V_{CCI}	0.75 * V_{CCI}	6	6	39	32	10	10
8 mA	-0.3	0.30 * V_{CCI}	0.7 * V_{CCI}	3.6	0.25 * V_{CCI}	0.75 * V_{CCI}	8	8	55	66	10	10
12 mA	-0.3	0.30 * V_{CCI}	0.7 * V_{CCI}	3.6	0.25 * V_{CCI}	0.75 * V_{CCI}	12	12	55	66	10	10

Notes:

1. Currents are measured at high temperature (100°C junction temperature) and maximum voltage.
2. Currents are measured at 125°C junction temperature.
3. Software default selection highlighted in gray.

**Table 2-66 • Minimum and Maximum DC Input and Output Levels
Applicable to Standard Plus I/O Banks**

1.5 V LVCMOS	VIL		VIH		VOL	VOH	I _{OL}	I _{OH}	I _{OSL}	I _{OSH}	I _{IL}	I _{IH}
Drive Strength	Min. V	Max. V	Min. V	Max. V	Max. V	Min. V	mA	mA	Max. mA ¹	Max. mA ¹	μA ²	μA ²
2 mA	-0.3	0.30 * V _{CCI}	0.7 * V _{CCI}	3.6	0.25 * V _{CCI}	0.75 * V _{CCI}	2	2	0	0	10	10
4 mA	-0.3	0.30 * V _{CCI}	0.7 * V _{CCI}	3.6	0.25 * V _{CCI}	0.75 * V _{CCI}	4	4	0	0	10	10

Notes:

1. Currents are measured at high temperature (100°C junction temperature) and maximum voltage.
2. Currents are measured at 125°C junction temperature.
3. Software default selection highlighted in gray.

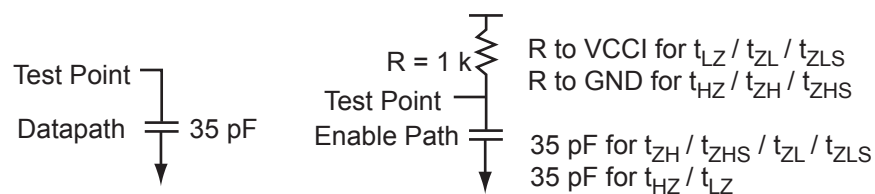
Figure 2-10 • AC Loading
Table 2-67 • AC Waveforms, Measuring Points, and Capacitive Loads

Input Low (V)	Input High (V)	Measuring Point* (V)	C _{LOAD} (pF)
0	1.5	0.75	35

Note: *Measuring point = V_{trip} . See Table 2-18 on page 2-17 for a complete table of trip points.

Timing Characteristics
Table 2-68 • 1.5 V LVC MOS High Slew
**Automotive-Case Conditions: $T_J = 135^\circ\text{C}$, Worst-Case $V_{CC} = 1.425\text{ V}$, Worst-Case $V_{CCI} = 2.3\text{ V}$
 Applicable to Advanced I/O Banks**

Drive Strength	Speed Grade	t_{DOUT}	t_{DP}	t_{DIN}	t_{PY}	t_{EOUT}	t_{ZL}	t_{ZH}	t_{LZ}	t_{HZ}	t_{ZLS}	t_{ZHS}	Units
2 mA	STD	0.64	9.35	0.05	1.61	0.46	7.63	9.35	1.87	1.50	10.13	11.851	ns
	-1	0.55	7.95	0.04	1.37	0.39	6.49	7.95	1.87	1.50	8.62	10.081	ns
4 mA	STD	0.64	5.94	0.05	1.61	0.46	5.42	5.94	2.07	1.84	7.92	8.442	ns
	-1	0.55	5.05	0.04	1.37	0.39	4.61	5.05	2.07	1.85	6.74	7.181	ns
6 mA	STD	0.64	5.22	0.05	1.61	0.46	5.09	5.22	2.11	1.93	7.59	7.718	ns
	-1	0.55	4.44	0.04	1.37	0.39	4.33	4.44	2.11	1.93	6.45	6.566	ns
8 mA	STD	0.64	4.56	0.05	1.61	0.46	2.25	1.98	4.41	4.70	3.46	3.211	ns
	-1	0.55	3.88	0.04	1.37	0.39	2.25	1.98	3.75	4.00	3.46	3.213	ns
12 mA	STD	0.64	4.56	0.05	1.61	0.46	2.25	1.98	4.41	4.70	3.46	3.211	ns
	-1	0.55	3.88	0.04	1.37	0.39	2.25	1.98	3.75	4.00	3.46	3.213	ns

Notes:

1. Software default selection highlighted in gray.
2. For specific junction temperature and voltage supply levels, refer to [Table 2-5 on page 2-5](#) for derating values.

Table 2-69 • 1.5 V LVC MOS Low Slew
**Automotive-Case Conditions: $T_J = 135^\circ\text{C}$, Worst-Case $V_{CC} = 1.425\text{ V}$, Worst-Case $V_{CCI} = 2.3\text{ V}$
 Applicable to Advanced I/O Banks**

Drive Strength	Speed Grade	t_{DOUT}	t_{DP}	t_{DIN}	t_{PY}	t_{EOUT}	t_{ZL}	t_{ZH}	t_{LZ}	t_{HZ}	t_{ZLS}	t_{ZHS}	Units
2 mA	STD	0.64	14.29	0.05	1.45	0.46	14.32	14.29	1.88	1.43	16.82	16.794	ns
	-1	0.55	12.16	0.04	1.23	0.39	12.18	12.16	1.88	1.43	14.31	14.286	ns
4 mA	STD	0.64	11.19	0.05	1.45	0.46	11.40	10.67	2.07	1.77	13.90	13.175	ns
	-1	0.55	9.52	0.04	1.23	0.39	9.70	9.08	2.07	1.77	11.82	11.207	ns
6 mA	STD	0.64	10.44	0.05	1.45	0.46	10.63	9.94	2.12	1.86	13.13	12.442	ns
	-1	0.55	8.88	0.04	1.23	0.39	9.04	8.46	2.12	1.86	11.17	10.584	ns
8 mA	STD	0.64	9.96	0.05	1.45	0.46	10.15	9.94	2.18	2.19	12.65	12.445	ns
	-1	0.55	8.47	0.04	1.23	0.39	8.63	8.46	2.19	2.20	10.76	10.586	ns
12 mA	STD	0.64	9.96	0.05	1.45	0.46	10.15	9.94	2.18	2.19	12.65	12.445	ns
	-1	0.55	8.47	0.04	1.23	0.39	8.63	8.46	2.19	2.20	10.76	10.586	ns

Note: For specific junction temperature and voltage supply levels, refer to [Table 2-5 on page 2-5](#) for derating values.

Table 2-70 • 1.5 V LVC MOS High Slew

Automotive-Case Conditions: $T_J = 135^\circ\text{C}$, Worst-Case VCC = 1.425 V, Worst-Case VCCI = 2.3 V
 Applicable to Standard Plus I/O Banks

Drive Strength	Speed Grade	t_{DOUT}	t_{DP}	t_{DIN}	t_{PY}	t_{EOUT}	t_{ZL}	t_{ZH}	t_{LZ}	t_{HZ}	t_{ZLS}	t_{ZHS}	Units
2 mA	STD	0.64	8.76	0.05	1.59	0.46	7.63	9.35	1.87	1.50	10.13	11.851	ns
	-1	0.55	7.45	0.04	1.35	0.39	6.49	7.95	1.87	1.50	8.62	10.081	ns
4 mA	STD	0.64	5.41	0.05	1.59	0.46	5.42	5.94	2.07	1.84	7.92	8.442	ns
	-1	0.55	4.60	0.04	1.35	0.39	4.61	5.05	2.07	1.85	6.74	7.181	ns

Notes:

1. Software default selection highlighted in gray.
2. For specific junction temperature and voltage supply levels, refer to [Table 2-5 on page 2-5](#) for derating values.

Table 2-71 • 1.5 V LVC MOS Low Slew

Automotive-Case Conditions: $T_J = 135^\circ\text{C}$, Worst-Case VCC = 1.425 V, Worst-Case VCCI = 2.3 V
 Applicable to Standard Plus I/O Banks

Drive Strength	Speed Grade	t_{DOUT}	t_{DP}	t_{DIN}	t_{PY}	t_{EOUT}	t_{ZL}	t_{ZH}	t_{LZ}	t_{HZ}	t_{ZLS}	t_{ZHS}	Units
2 mA	STD	0.64	13.51	0.05	1.45	0.46	14.32	14.29	1.88	1.43	16.82	16.794	ns
	-1	0.55	11.49	0.04	1.23	0.39	12.18	12.16	1.88	1.43	14.31	14.286	ns
4 mA	STD	0.64	10.38	0.05	1.45	0.46	11.40	10.67	2.07	1.77	13.90	13.175	ns
	-1	0.55	8.83	0.04	1.23	0.39	9.70	9.08	2.07	1.77	11.82	11.207	ns

Note: For specific junction temperature and voltage supply levels, refer to [Table 2-5 on page 2-5](#) for derating values.

Table 2-72 • 1.5 V LVC MOS High Slew

Automotive-Case Conditions: $T_J = 115^\circ\text{C}$, Worst-Case VCC = 1.425 V, Worst-Case VCCI = 2.3 V
 Applicable to Advanced I/O Banks

Drive Strength	Speed Grade	t_{DOUT}	t_{DP}	t_{DIN}	t_{PY}	t_{EOUT}	t_{ZL}	t_{ZH}	t_{LZ}	t_{HZ}	t_{ZLS}	t_{ZHS}	Units
2 mA	STD	0.63	9.05	0.05	1.56	0.45	7.38	9.05	1.81	1.45	9.80	11.47	ns
	-1	0.53	7.70	0.04	1.32	0.38	6.28	7.70	1.81	1.45	8.34	9.75	ns
4 mA	STD	0.63	5.75	0.05	1.56	0.45	5.25	5.75	2.00	1.78	7.67	8.17	ns
	-1	0.53	4.89	0.04	1.32	0.38	4.46	4.89	2.00	1.78	6.52	6.95	ns
6 mA	STD	0.63	5.05	0.05	1.56	0.45	4.92	5.05	2.04	1.87	7.34	7.47	ns
	-1	0.53	4.29	0.04	1.32	0.38	4.19	4.29	2.04	1.87	6.24	6.35	ns
8 mA	STD	0.63	4.41	0.05	1.56	0.45	2.18	1.91	4.27	4.55	3.35	3.11	ns
	-1	0.53	3.75	0.04	1.32	0.38	2.18	1.91	3.63	3.87	3.35	3.11	ns
12 mA	STD	0.63	4.41	0.05	1.56	0.45	2.18	1.91	4.27	4.55	3.35	3.11	ns
	-1	0.53	3.75	0.04	1.32	0.38	2.18	1.91	3.63	3.87	3.35	3.11	ns

Notes:

1. Software default selection highlighted in gray.
2. For specific junction temperature and voltage supply levels, refer to [Table 2-5 on page 2-5](#) for derating values.

Table 2-73 • 1.5 V LVC MOS Low Slew

Automotive-Case Conditions: $T_J = 115^\circ\text{C}$, Worst-Case VCC = 1.425 V, Worst-Case VCCI = 2.3 V
Applicable to Advanced I/O Banks

Drive Strength	Speed Grade	t_{DOUT}	t_{DP}	t_{DIN}	t_{PY}	t_{EOUT}	t_{ZL}	t_{ZH}	t_{LZ}	t_{HZ}	t_{ZLS}	t_{ZHS}	Units
2 mA	STD	0.63	13.83	0.05	1.40	0.45	13.86	13.83	1.82	1.39	16.28	16.25	ns
	-1	0.53	11.76	0.04	1.19	0.38	11.79	11.76	1.82	1.39	13.85	13.82	ns
4 mA	STD	0.63	10.83	0.05	1.40	0.45	11.03	10.33	2.00	1.71	13.45	12.75	ns
	-1	0.53	9.21	0.04	1.19	0.38	9.38	8.79	2.01	1.72	11.44	10.84	ns
6 mA	STD	0.63	10.10	0.05	1.40	0.45	10.28	9.62	2.05	1.80	12.70	12.04	ns
	-1	0.53	8.59	0.04	1.19	0.38	8.75	8.18	2.05	1.80	10.81	10.24	ns
8 mA	STD	0.63	9.64	0.05	1.40	0.45	9.82	9.62	2.11	2.12	12.23	12.04	ns
	-1	0.53	8.20	0.04	1.19	0.38	8.35	8.18	2.11	2.12	10.41	10.24	ns
12 mA	STD	0.63	9.64	0.05	1.40	0.45	9.82	9.62	2.11	2.12	12.23	12.04	ns
	-1	0.53	8.20	0.04	1.19	0.38	8.35	8.18	2.11	2.12	10.41	10.24	ns

Note: For specific junction temperature and voltage supply levels, refer to Table 2-5 on page 2-5 for derating values.

Table 2-74 • 1.5 V LVC MOS High Slew

Automotive-Case Conditions: $T_J = 115^\circ\text{C}$, Worst-Case VCC = 1.425 V, Worst-Case VCCI = 2.3 V
Applicable to Standard Plus I/O Banks

Drive Strength	Speed Grade	t_{DOUT}	t_{DP}	t_{DIN}	t_{PY}	t_{EOUT}	t_{ZL}	t_{ZH}	t_{LZ}	t_{HZ}	t_{ZLS}	t_{ZHS}	Units
2 mA	STD	0.63	8.47	0.05	1.54	0.45	7.38	9.05	1.81	1.45	9.80	11.47	ns
	-1	0.53	7.21	0.04	1.31	0.38	6.28	7.70	1.81	1.45	8.34	9.75	ns
4 mA	STD	0.63	5.24	0.05	1.54	0.45	5.25	5.75	2.00	1.78	7.67	8.17	ns
	-1	0.53	4.45	0.04	1.31	0.38	4.46	4.89	2.00	1.78	6.52	6.95	ns

Notes:

1. Software default selection highlighted in gray.
2. For specific junction temperature and voltage supply levels, refer to Table 2-5 on page 2-5 for derating values.

Table 2-75 • 1.5 V LVC MOS Low Slew

Automotive-Case Conditions: $T_J = 115^\circ\text{C}$, Worst-Case VCC = 1.425 V, Worst-Case VCCI = 2.3 V
Applicable to Standard Plus I/O Banks

Drive Strength	Speed Grade	t_{DOUT}	t_{DP}	t_{DIN}	t_{PY}	t_{EOUT}	t_{ZL}	t_{ZH}	t_{LZ}	t_{HZ}	t_{ZLS}	t_{ZHS}	Units
2 mA	STD	0.63	13.07	0.05	1.40	0.45	13.86	13.83	1.82	1.39	16.28	16.25	ns
	-1	0.53	11.12	0.04	1.19	0.38	11.79	11.76	1.82	1.39	13.85	13.82	ns
4 mA	STD	0.63	10.04	0.05	1.40	0.45	11.03	10.33	2.00	1.71	13.45	12.75	ns
	-1	0.53	8.54	0.04	1.19	0.38	9.38	8.79	2.01	1.72	11.44	10.84	ns

Note: For specific junction temperature and voltage supply levels, refer to Table 2-5 on page 2-5 for derating values.

3.3 V PCI, 3.3 V PCI-X

The Peripheral Component Interface for 3.3 V standard specifies support for 33 MHz and 66 MHz PCI Bus applications.

Table 2-76 • Minimum and Maximum DC Input and Output Levels

3.3 V PCI/PCI-X	VIL		VIH		VOL	VOH	I _{OL}	I _{OH}	I _{OSL}	I _{OSH}	I _{IL}	I _{IH}
	Min. V	Max. V	Min. V	Max. V	Max. V	Min. V	mA	mA	Max. mA ¹	Max. mA ¹	μA ²	μA ²
Per PCI specification	Per PCI curves										10	10

Notes:

1. Currents are measured at high temperature (100°C junction temperature) and maximum voltage.
2. Currents are measured at 125°C junction temperature.

AC loadings are defined per the PCI/PCI-X specifications for the datapath; Microsemi loadings for enable path characterization are described in [Figure 2-11](#).

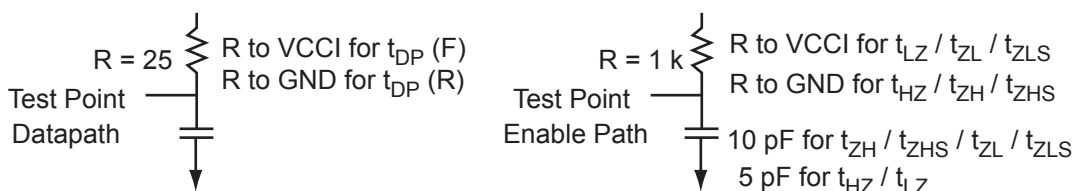

Figure 2-11 • AC Loading

AC loadings are defined per PCI/PCI-X specifications for the datapath; Actel loading for tristate is described in [Table 2-77](#).

Table 2-77 • AC Waveforms, Measuring Points, and Capacitive Loads

Input Low (V)	Input High (V)	Measuring Point* (V)	C _{LOAD} (pF)
0	3.3	0.285 * VCCI for $t_{DP}(R)$ 0.615 * VCCI for $t_{DP}(F)$	10

Note: *Measuring point = V_{trip} . See [Table 2-18](#) on page 2-17 for a complete table of trip points.

Timing Characteristics

Table 2-78 • 3.3 V PCI/PCI-X

Automotive-Case Conditions: $T_J = 135^\circ\text{C}$, Worst-Case VCC = 1.425 V, Worst-Case VCCI = 3.0 V
Applicable to Advanced I/O Banks

Speed Grade	t_{DOUT}	t_{DP}	t_{DIN}	t_{PY}	t_{EOUT}	t_{ZL}	t_{ZH}	t_{LZ}	t_{HZ}	t_{ZLS}	t_{ZHS}	Units
Std.	0.64	2.58	0.05	0.95	0.46	1.27	0.94	3.12	3.60	2.49	2.18	ns
-1	0.55	2.19	0.04	0.81	0.39	1.27	0.94	2.65	3.06	2.49	2.18	ns

Note: For specific junction temperature and voltage supply levels, refer to [Table 2-5](#) on page 2-5 for derating values.

Table 2-79 • 3.3 V PCI/PCI-X

Automotive-Case Conditions: $T_J = 135^\circ\text{C}$, Worst-Case VCC = 1.425 V, Worst-Case VCCI = 3.0 V
Applicable to Standard Plus I/O Banks

Speed Grade	t_{DOUT}	t_{DP}	t_{DIN}	t_{PY}	t_{EOUT}	t_{ZL}	t_{ZH}	t_{LZ}	t_{HZ}	t_{ZLS}	t_{ZHS}	Units
Std.	0.64	3.00	0.05	0.93	0.46	1.27	0.94	3.12	3.60	2.49	2.18	ns
-1	0.55	2.55	0.04	0.79	0.39	1.27	0.94	2.65	3.06	2.49	2.18	ns

Note: For specific junction temperature and voltage supply levels, refer to [Table 2-5](#) on page 2-5 for derating values.

Table 2-80 • 3.3 V PCI/PCI-X

Automotive-Case Conditions: $T_J = 115^\circ\text{C}$, Worst-Case VCC = 1.425 V, Worst-Case VCCI = 3.0 V
Applicable to Advanced I/O Banks

Speed Grade	t_{DOUT}	t_{DP}	t_{DIN}	t_{PY}	t_{EOUT}	t_{ZL}	t_{ZH}	t_{LZ}	t_{HZ}	t_{ZLS}	t_{ZHS}	Units
Std.	0.628	2.50	0.05	0.92	0.45	1.23	0.91	3.02	3.48	2.40	2.11	ns
-1	0.53	2.12	0.04	0.78	0.38	1.23	0.91	2.57	2.96	2.41	2.11	ns

Note: For specific junction temperature and voltage supply levels, refer to [Table 2-5 on page 2-5](#) for derating values.

Table 2-81 • 3.3 V PCI/PCI-X

Automotive-Case Conditions: $T_J = 115^\circ\text{C}$, Worst-Case VCC = 1.425 V, Worst-Case VCCI = 3.0 V
Applicable to Standard Plus I/O Banks

Speed Grade	t_{DOUT}	t_{DP}	t_{DIN}	t_{PY}	t_{EOUT}	t_{ZL}	t_{ZH}	t_{LZ}	t_{HZ}	t_{ZLS}	t_{ZHS}	Units
Std.	0.628	2.90	0.05	0.90	0.45	1.23	0.91	3.02	3.48	2.40	2.11	ns
-1	0.53	2.47	0.04	0.77	0.38	1.23	0.91	2.57	2.96	2.41	2.11	ns

Note: For specific junction temperature and voltage supply levels, refer to [Table 2-5 on page 2-5](#) for derating values.

Differential I/O Characteristics

Physical Implementation

Configuration of the I/O modules as a differential pair is handled by Actel Designer software when the user instantiates a differential I/O macro in the design.

Differential I/Os can also be used in conjunction with the embedded Input Register (InReg), Output Register (OutReg), Enable Register (EnReg), and Double Data Rate (DDR). However, there is no support for bidirectional I/Os or tristates with the LVPECL standards.

LVDS

Low-Voltage Differential Signaling (ANSI/TIA/EIA-644) is a high-speed, differential I/O standard. It requires that one data bit be carried through two signal lines, so two pins are needed. It also requires external resistor termination.

The full implementation of the LVDS transmitter and receiver is shown in an example in [Figure 2-12 on page 2-50](#). The building blocks of the LVDS transmitter-receiver are one transmitter macro, one receiver macro, three board resistors at the transmitter end, and one resistor at the receiver end. The values for the three driver resistors are different from those used in the LVPECL implementation because the output standard specifications are different.

Along with LVDS I/O, ProASIC3 also supports Bus LVDS structure and Multipoint LVDS (M-LVDS) configuration (up to 40 nodes).

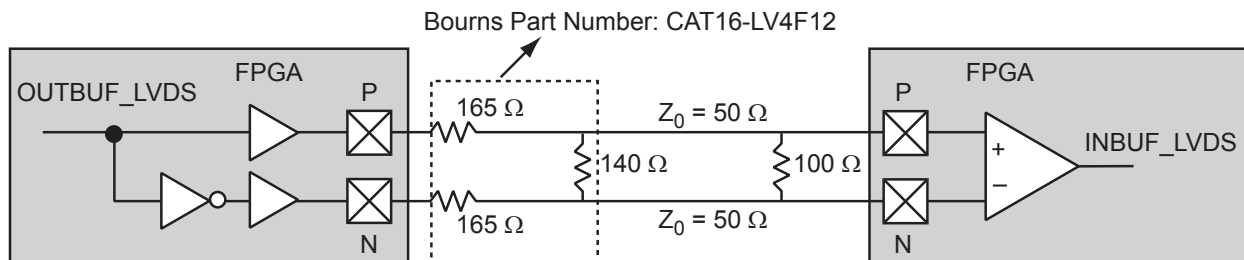
Figure 2-12 • LVDS Circuit Diagram and Board-Level Implementation
Table 2-82 • Minimum and Maximum DC Input and Output Levels

DC Parameter	Description	Min.	Typ.	Max.	Units
VCCI	Supply Voltage	2.375	2.5	2.625	V
VOL	Output Low Voltage	0.9	1.075	1.25	V
VOH	Output High Voltage	1.25	1.425	1.6	V
VI	Input Voltage	0	–	2.925	V
VODIFF	Differential Output Voltage	250	350	450	mV
VOCM	Output Common-Mode Voltage	1.125	1.25	1.375	V
VICM	Input Common-Mode Voltage	0.05	1.25	2.35	V
VIDIFF	Input Differential Voltage	100	350	–	mV

Table 2-83 • AC Waveforms, Measuring Points, and Capacitive Loads

Input Low (V)	Input High (V)	Measuring Point* (V)
1.075	1.325	Cross point

Note: *Measuring point = V_{trip} . See Table 2-18 on page 2-17 for a complete table of trip points.

Timing Characteristics

Table 2-84 • LVDS

Automotive-Case Conditions: $T_J = 135^\circ\text{C}$, Worst-Case VCC = 1.425 V, Worst-Case VCCI = 2.3 V

Speed Grade	t_{DOUT}	t_{DP}	t_{DIN}	t_{pY}	Units
Std.	0.64	2.05	0.05	1.79	ns
–1	0.55	1.74	0.04	1.52	ns

Note: For specific junction temperature and voltage supply levels, refer to Table 2-5 on page 2-5 for derating values.

Table 2-85 • LVDS

Automotive-Case Conditions: $T_J = 115^\circ\text{C}$, Worst-Case VCC = 1.425 V, Worst-Case VCCI = 2.3 V

Speed Grade	t_{DOUT}	t_{DP}	t_{DIN}	t_{pY}	Units
Std.	0.63	1.98	0.05	1.73	ns
–1	0.53	1.68	0.04	1.47	ns

Note: For specific junction temperature and voltage supply levels, refer to Table 2-5 on page 2-5 for derating values.

B-LVDS/M-LVDS

Bus LVDS (B-LVDS) and Multipoint LVDS (M-LVDS) specifications extend the existing LVDS standard to high-performance multipoint bus applications. Multidrop and multipoint bus configurations may contain any combination of drivers, receivers, and transceivers. Actel LVDS drivers provide the higher drive current required by B-LVDS and M-LVDS to accommodate the loading. The drivers require series terminations for better signal quality and to control voltage swing. Termination is also required at both ends of the bus since the driver can be located anywhere on the bus. These configurations can be implemented using the TRIBUF_LVDS and BIBUF_LVDS macros along with appropriate terminations. Multipoint designs using Actel LVDS macros can achieve up to 200 MHz with a maximum of 20 loads. A sample application is given in [Figure 2-13](#). The input and output buffer delays are available in the LVDS section in [Table 2-84](#) on page 2-50.

Example: For a bus consisting of 20 equidistant loads, the following terminations provide the required differential voltage, in worst-case Industrial operating conditions, at the farthest receiver: $R_S = 60 \Omega$ and $R_T = 70 \Omega$, given $Z_0 = 50 \Omega$ (2") and $Z_{stub} = 50 \Omega$ (~1.5").

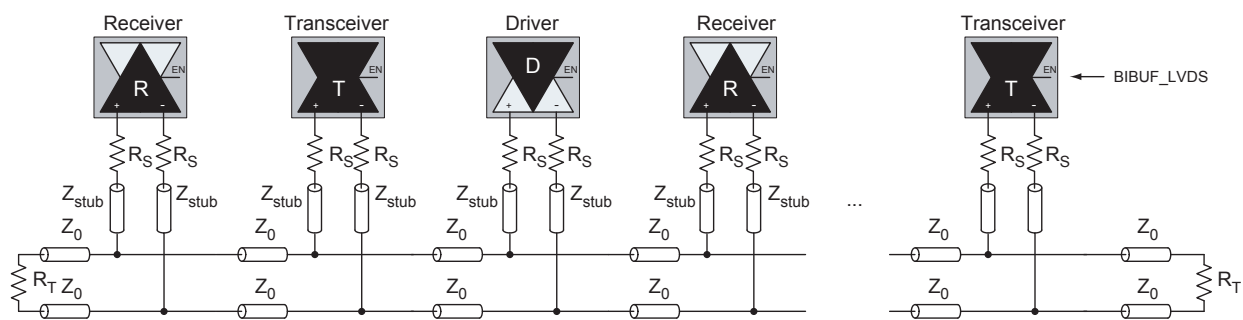

Figure 2-13 • B-LVDS/M-LVDS Multipoint Application Using LVDS I/O Buffers

LVPECL

Low-Voltage Positive Emitter-Coupled Logic (LVPECL) is another differential I/O standard. It requires that one data bit be carried through two signal lines. Like LVDS, two pins are needed. It also requires external resistor termination.

The full implementation of the LVDS transmitter and receiver is shown in an example in [Figure 2-14](#) on page 2-52. The building blocks of the LVPECL transmitter-receiver are one transmitter macro, one receiver macro, three board resistors at the transmitter end, and one resistor at the receiver end. The values for the three driver resistors are different from those used in the LVDS implementation because the output standard specifications are different.

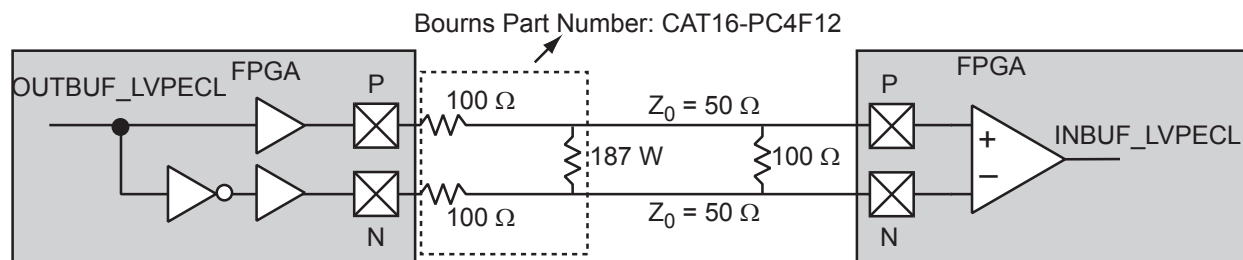

Figure 2-14 • LVPECL Circuit Diagram and Board-Level Implementation

Table 2-86 • Minimum and Maximum DC Input and Output Levels

DC Parameter	Description	Min.	Max.	Min.	Max.	Min.	Max.	Units
VCCI	Supply Voltage	3.0		3.3		3.6		V
VOL	Output Low Voltage	0.96	1.27	1.06	1.43	1.30	1.57	V
VOH	Output High Voltage	1.8	2.11	1.92	2.28	2.13	2.41	V
VIL, VIH	Input Low, Input High Voltages	0	3.6	0	3.6	0	3.6	V
VODIFF	Differential Output Voltage	0.625	0.97	0.625	0.97	0.625	0.97	V
VOCM	Output Common-Mode Voltage	1.762	1.98	1.762	1.98	1.762	1.98	V
VICM	Input Common-Mode Voltage	1.01	2.57	1.01	2.57	1.01	2.57	V
VIDIFF	Input Differential Voltage	300		300		300		mV

Table 2-87 • AC Waveforms, Measuring Points, and Capacitive Loads

Input Low (V)	Input High (V)	Measuring Point* (V)
1.64	1.94	Cross point

Note: *Measuring point = V_{trip} . See Table 2-18 on page 2-17 for a complete table of trip points.

Timing Characteristics

Table 2-88 • LVPECL

Automotive-Case Conditions: $T_j = 135^\circ\text{C}$, Worst-Case VCC = 1.425 V, Worst-Case VCCI = 3.0 V

Speed Grade	t_{DOUT}	t_{DP}	t_{DIN}	t_{PY}	Units
Std.	0.64	2.01	0.05	1.57	ns
-1	0.55	1.71	0.04	1.34	ns

Note: For specific junction temperature and voltage supply levels, refer to Table 2-5 on page 2-5 for derating values.

Table 2-89 • LVPECL

Automotive-Case Conditions: $T_j = 115^\circ\text{C}$, Worst-Case VCC = 1.425 V, Worst-Case VCCI = 3.0 V

Speed Grade	t_{DOUT}	t_{DP}	t_{DIN}	t_{PY}	Units
Std.	0.63	1.95	0.05	1.52	ns
-1	0.53	1.66	0.04	1.29	ns

Note: For specific junction temperature and voltage supply levels, refer to Table 2-5 on page 2-5 for derating values.

I/O Register Specifications

Fully Registered I/O Buffers with Synchronous Enable and Asynchronous Preset

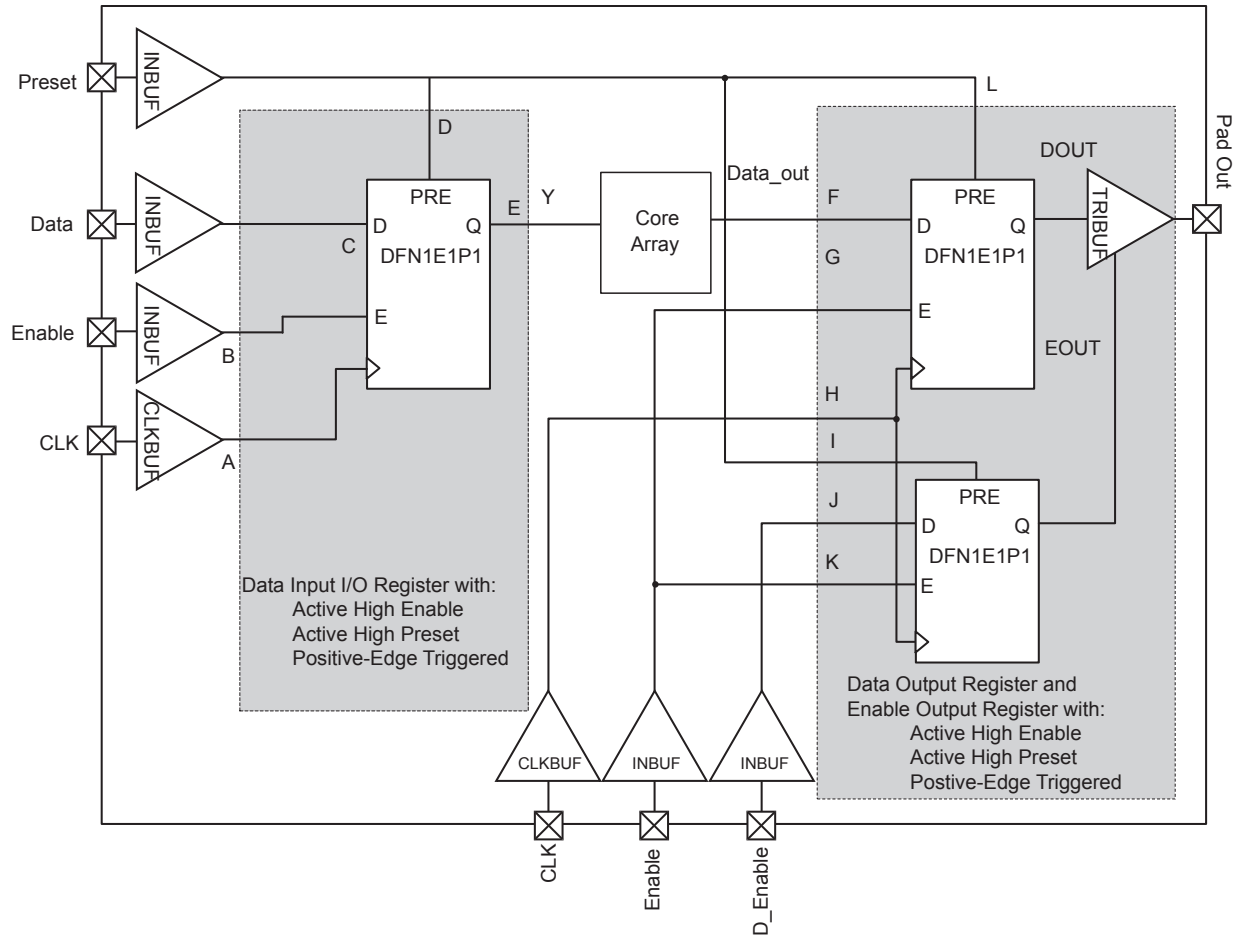

Figure 2-15 • Timing Model of Registered I/O Buffers with Synchronous Enable and Asynchronous Preset

Table 2-90 • Parameter Definition and Measuring Nodes

Parameter Name	Parameter Definition	Measuring Nodes (from, to)*
t_{OCLKQ}	Clock-to-Q of the Output Data Register	H, DOUT
t_{OSUD}	Data Setup Time for the Output Data Register	F, H
t_{OHD}	Data Hold Time for the Output Data Register	F, H
t_{OSUE}	Enable Setup Time for the Output Data Register	G, H
t_{OHE}	Enable Hold Time for the Output Data Register	G, H
t_{OPRE2Q}	Asynchronous Preset-to-Q of the Output Data Register	L, DOUT
$t_{OREMPRE}$	Asynchronous Preset Removal Time for the Output Data Register	L, H
$t_{ORECPRE}$	Asynchronous Preset Recovery Time for the Output Data Register	L, H
t_{OECLKQ}	Clock-to-Q of the Output Enable Register	H, EOUT
t_{OESUD}	Data Setup Time for the Output Enable Register	J, H
t_{OEHD}	Data Hold Time for the Output Enable Register	J, H
t_{OESUE}	Enable Setup Time for the Output Enable Register	K, H
t_{OEHE}	Enable Hold Time for the Output Enable Register	K, H
$t_{OEPRE2Q}$	Asynchronous Preset-to-Q of the Output Enable Register	I, EOUT
$t_{OEREMPRE}$	Asynchronous Preset Removal Time for the Output Enable Register	I, H
$t_{OERECPRE}$	Asynchronous Preset Recovery Time for the Output Enable Register	I, H
t_{iCLKQ}	Clock-to-Q of the Input Data Register	A, E
t_{iSUD}	Data Setup Time for the Input Data Register	C, A
t_{iHD}	Data Hold Time for the Input Data Register	C, A
t_{iSUE}	Enable Setup Time for the Input Data Register	B, A
t_{iHE}	Enable Hold Time for the Input Data Register	B, A
t_{iPRE2Q}	Asynchronous Preset-to-Q of the Input Data Register	D, E
$t_{iREMPRE}$	Asynchronous Preset Removal Time for the Input Data Register	D, A
$t_{iRECPRE}$	Asynchronous Preset Recovery Time for the Input Data Register	D, A

Note: *See Figure 2-15 on page 2-53 for more information.

Fully Registered I/O Buffers with Synchronous Enable and Asynchronous Clear

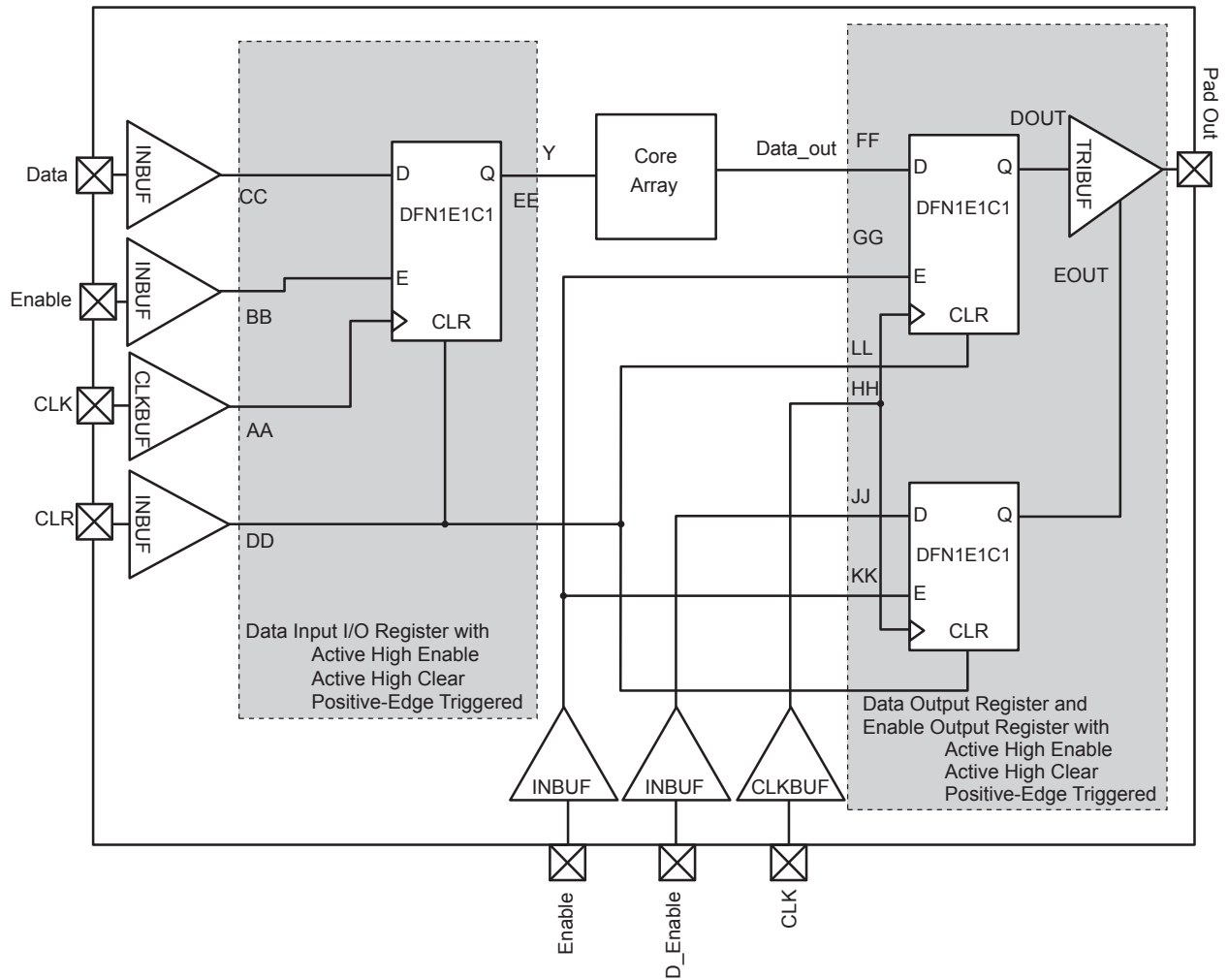

Figure 2-16 • Timing Model of the Registered I/O Buffers with Synchronous Enable and Asynchronous Clear

Table 2-91 • Parameter Definitions and Measuring Nodes

Parameter Name	Parameter Definition	Measuring Nodes (from, to)*
t_{OCLKQ}	Clock-to-Q of the Output Data Register	HH, DOUT
t_{OSUD}	Data Setup Time for the Output Data Register	FF, HH
t_{OHD}	Data Hold Time for the Output Data Register	FF, HH
t_{OSUE}	Enable Setup Time for the Output Data Register	GG, HH
t_{OHE}	Enable Hold Time for the Output Data Register	GG, HH
t_{OCLR2Q}	Asynchronous Clear-to-Q of the Output Data Register	LL, DOUT
$t_{OERMCLR}$	Asynchronous Clear Removal Time for the Output Data Register	LL, HH
$t_{ORECCLR}$	Asynchronous Clear Recovery Time for the Output Data Register	LL, HH
t_{OECLKQ}	Clock-to-Q of the Output Enable Register	HH, EOUT
t_{OESUD}	Data Setup Time for the Output Enable Register	JJ, HH
t_{OEHD}	Data Hold Time for the Output Enable Register	JJ, HH
t_{OESUE}	Enable Setup Time for the Output Enable Register	KK, HH
t_{OEHE}	Enable Hold Time for the Output Enable Register	KK, HH
$t_{OECLR2Q}$	Asynchronous Clear-to-Q of the Output Enable Register	II, EOUT
$t_{OERMCLR}$	Asynchronous Clear Removal Time for the Output Enable Register	II, HH
$t_{OERCCLR}$	Asynchronous Clear Recovery Time for the Output Enable Register	II, HH
t_{ICLKQ}	Clock-to-Q of the Input Data Register	AA, EE
t_{ISUD}	Data Setup Time for the Input Data Register	CC, AA
t_{IHD}	Data Hold Time for the Input Data Register	CC, AA
t_{ISUE}	Enable Setup Time for the Input Data Register	BB, AA
t_{IHE}	Enable Hold Time for the Input Data Register	BB, AA
t_{ICLR2Q}	Asynchronous Clear-to-Q of the Input Data Register	DD, EE
$t_{IERMCLR}$	Asynchronous Clear Removal Time for the Input Data Register	DD, AA
$t_{IRECCLR}$	Asynchronous Clear Recovery Time for the Input Data Register	DD, AA

Note: *See Figure 2-16 on page 2-55 for more information.

Input Register

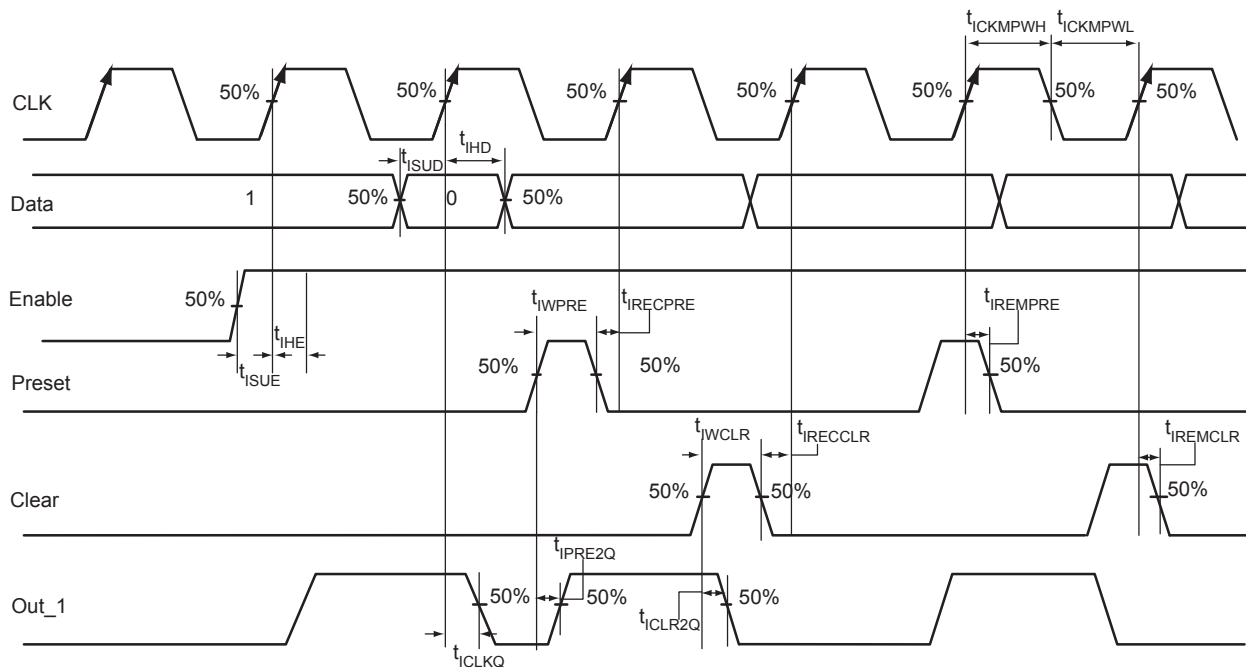

Figure 2-17 • Input Register Timing Diagram

Timing Characteristics

Table 2-92 • Input Data Register Propagation Delays
Automotive-Case Conditions: $T_j = 135^\circ\text{C}$, Worst-Case VCC = 1.425 V

Parameter	Description	-1	Std.	Units
t_{ICLKQ}	Clock-to-Q of the Input Data Register	0.29	0.34	ns
t_{ISUD}	Data Setup Time for the Input Data Register	0.32	0.38	ns
t_{IHD}	Data Hold Time for the Input Data Register	0.00	0.00	ns
t_{ISUE}	Enable Setup Time for the Input Data Register	0.45	0.53	ns
t_{IHE}	Enable Hold Time for the Input Data Register	0.00	0.00	ns
t_{ICLR2Q}	Asynchronous Clear-to-Q of the Input Data Register	0.55	0.65	ns
t_{IPRE2Q}	Asynchronous Preset-to-Q of the Input Data Register	0.55	0.65	ns
$t_{IREMCLR}$	Asynchronous Clear Removal Time for the Input Data Register	0.00	0.00	ns
$t_{IRECCLR}$	Asynchronous Clear Recovery Time for the Input Data Register	0.27	0.32	ns
$t_{IREMPRE}$	Asynchronous Preset Removal Time for the Input Data Register	0.00	0.00	ns
$t_{IRECPRE}$	Asynchronous Preset Recovery Time for the Input Data Register	0.27	0.32	ns
t_{IWCLR}	Asynchronous Clear Minimum Pulse Width for the Input Data Register	0.25	0.30	ns
t_{IWPRE}	Asynchronous Preset Minimum Pulse Width for the Input Data Register	0.25	0.30	ns
$t_{ICKMPWH}$	Clock Minimum Pulse Width High for the Input Data Register	0.41	0.48	ns
$t_{ICKMPWL}$	Clock Minimum Pulse Width Low for the Input Data Register	0.37	0.43	ns

Note: For specific junction temperature and voltage supply levels, refer to Table 2-5 on page 2-5 for derating values.

Table 2-93 • Input Data Register Propagation Delays
 Automotive-Case Conditions: $T_J = 115^{\circ}\text{C}$, Worst-Case $V_{CC} = 1.425\text{ V}$

Parameter	Description	-1	Std.	Units
t_{CLKQ}	Clock-to-Q of the Input Data Register	0.29	0.34	ns
t_{ISUD}	Data Setup Time for the Input Data Register	0.31	0.37	ns
t_{IHD}	Data Hold Time for the Input Data Register	0.00	0.00	ns
t_{ISUE}	Enable Setup Time for the Input Data Register	0.44	0.52	ns
t_{IHE}	Enable Hold Time for the Input Data Register	0.00	0.00	ns
t_{CLR2Q}	Asynchronous Clear-to-Q of the Input Data Register	0.54	0.64	ns
t_{PRE2Q}	Asynchronous Preset-to-Q of the Input Data Register	0.54	0.64	ns
t_{REMCLR}	Asynchronous Clear Removal Time for the Input Data Register	0.00	0.00	ns
t_{RECCLR}	Asynchronous Clear Recovery Time for the Input Data Register	0.27	0.31	ns
t_{REMPRE}	Asynchronous Preset Removal Time for the Input Data Register	0.00	0.00	ns
t_{RECPRE}	Asynchronous Preset Recovery Time for the Input Data Register	0.27	0.31	ns
t_{WCLR}	Asynchronous Clear Minimum Pulse Width for the Input Data Register	0.25	0.30	ns
t_{WPRE}	Asynchronous Preset Minimum Pulse Width for the Input Data Register	0.25	0.30	ns
t_{CKMPWH}	Clock Minimum Pulse Width High for the Input Data Register	0.41	0.48	ns
t_{CKMPWL}	Clock Minimum Pulse Width Low for the Input Data Register	0.37	0.43	ns

Note: For specific junction temperature and voltage supply levels, refer to [Table 2-5 on page 2-5](#) for derating values.

Table 2-95 • Output Data Register Propagation Delays
 Automotive-Case Conditions: $T_J = 115^\circ\text{C}$, Worst-Case $V_{CC} = 1.425\text{ V}$

Parameter	Description	-1	Std.	Units
t_{OCLKQ}	Clock-to-Q of the Output Data Register	0.70	0.82	ns
t_{OSUD}	Data Setup Time for the Output Data Register	0.37	0.44	ns
t_{OHD}	Data Hold Time for the Output Data Register	0.00	0.00	ns
t_{OSUE}	Enable Setup Time for the Output Data Register	0.52	0.61	ns
t_{OHE}	Enable Hold Time for the Output Data Register	0.00	0.00	ns
t_{OCLR2Q}	Asynchronous Clear-to-Q of the Output Data Register	0.96	1.12	ns
t_{OPRE2Q}	Asynchronous Preset-to-Q of the Output Data Register	0.96	1.12	ns
$t_{OREMCLR}$	Asynchronous Clear Removal Time for the Output Data Register	0.00	0.00	ns
$t_{ORECCLR}$	Asynchronous Clear Recovery Time for the Output Data Register	0.27	0.31	ns
$t_{OREMPRE}$	Asynchronous Preset Removal Time for the Output Data Register	0.00	0.00	ns
$t_{ORECPRE}$	Asynchronous Preset Recovery Time for the Output Data Register	0.27	0.31	ns
t_{OWCLR}	Asynchronous Clear Minimum Pulse Width for the Output Data Register	0.25	0.30	ns
t_{OWPRE}	Asynchronous Preset Minimum Pulse Width for the Output Data Register	0.25	0.30	ns
$t_{OCKMPWH}$	Clock Minimum Pulse Width High for the Output Data Register	0.41	0.48	ns
$t_{OCKMPWL}$	Clock Minimum Pulse Width Low for the Output Data Register	0.37	0.43	ns

Note: For specific junction temperature and voltage supply levels, refer to [Table 2-5 on page 2-5](#) for derating values.

Output Enable Register

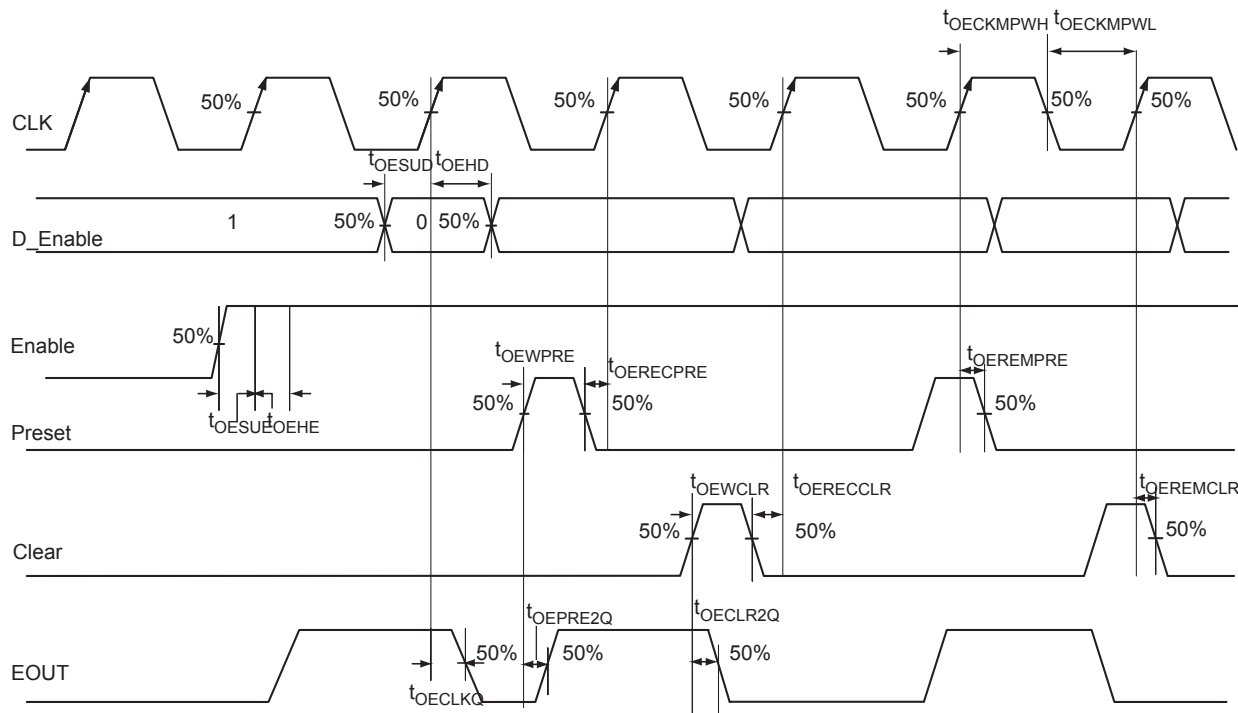

Figure 2-19 • Output Enable Register Timing Diagram

Timing Characteristics

Table 2-96 • Output Enable Register Propagation Delays
Automotive-Case Conditions: $T_J = 135^\circ\text{C}$, Worst-Case VCC = 1.425 V

Parameter	Description	-1	Std.	Units
t_{OECLKQ}	Clock-to-Q of the Output Enable Register	0.54	0.64	ns
t_{OESUD}	Data Setup Time for the Output Enable Register	0.38	0.45	ns
t_{OEHD}	Data Hold Time for the Output Enable Register	0.00	0.00	ns
t_{OESUE}	Enable Setup Time for the Output Enable Register	0.53	0.62	ns
t_{OEHE}	Enable Hold Time for the Output Enable Register	0.00	0.00	ns
$t_{OECLR2Q}$	Asynchronous Clear-to-Q of the Output Enable Register	0.81	0.95	ns
$t_{OEPRE2Q}$	Asynchronous Preset-to-Q of the Output Enable Register	0.81	0.95	ns
$t_{OEREMCLR}$	Asynchronous Clear Removal Time for the Output Enable Register	0.00	0.00	ns
$t_{OERECCLR}$	Asynchronous Clear Recovery Time for the Output Enable Register	0.27	0.32	ns
$t_{OEREMPRES}$	Asynchronous Preset Removal Time for the Output Enable Register	0.00	0.00	ns
$t_{OERECPRE}$	Asynchronous Preset Recovery Time for the Output Enable Register	0.27	0.32	ns
$t_{OEWCCLR}$	Asynchronous Clear Minimum Pulse Width for the Output Enable Register	0.25	0.30	ns
$t_{OEWCPRE}$	Asynchronous Preset Minimum Pulse Width for the Output Enable Register	0.25	0.30	ns
$t_{OECKMPWH}$	Clock Minimum Pulse Width High for the Output Enable Register	0.41	0.48	ns
$t_{OECKMPWL}$	Clock Minimum Pulse Width Low for the Output Enable Register	0.37	0.43	ns

Note: For specific junction temperature and voltage supply levels, refer to Table 2-5 on page 2-5 for derating values.

Table 2-97 • Output Enable Register Propagation Delays
 Automotive-Case Conditions: $T_J = 115^\circ\text{C}$, Worst-Case $V_{CC} = 1.425\text{ V}$

Parameter	Description	-1	Std.	Units
t_{OECLKQ}	Clock-to-Q of the Output Enable Register	0.53	0.62	ns
t_{OESUD}	Data Setup Time for the Output Enable Register	0.37	0.44	ns
t_{OEHD}	Data Hold Time for the Output Enable Register	0.00	0.00	ns
t_{OESUE}	Enable Setup Time for the Output Enable Register	0.52	0.61	ns
t_{OEHE}	Enable Hold Time for the Output Enable Register	0.00	0.00	ns
$t_{OECLR2Q}$	Asynchronous Clear-to-Q of the Output Enable Register	0.79	0.93	ns
$t_{OEPRE2Q}$	Asynchronous Preset-to-Q of the Output Enable Register	0.79	0.93	ns
$t_{OEREMCLR}$	Asynchronous Clear Removal Time for the Output Enable Register	0.00	0.00	ns
$t_{OERECCLR}$	Asynchronous Clear Recovery Time for the Output Enable Register	0.27	0.31	ns
$t_{OEREMPRE}$	Asynchronous Preset Removal Time for the Output Enable Register	0.00	0.00	ns
$t_{OERECPRE}$	Asynchronous Preset Recovery Time for the Output Enable Register	0.27	0.31	ns
$t_{OEWCCLR}$	Asynchronous Clear Minimum Pulse Width for the Output Enable Register	0.25	0.30	ns
$t_{OEWCPRE}$	Asynchronous Preset Minimum Pulse Width for the Output Enable Register	0.25	0.30	ns
$t_{OECKMPWH}$	Clock Minimum Pulse Width High for the Output Enable Register	0.41	0.48	ns
$t_{OECKMPWL}$	Clock Minimum Pulse Width Low for the Output Enable Register	0.37	0.43	ns

Note: For specific junction temperature and voltage supply levels, refer to [Table 2-5 on page 2-5](#) for derating values.

DDR Module Specifications

Input DDR Module

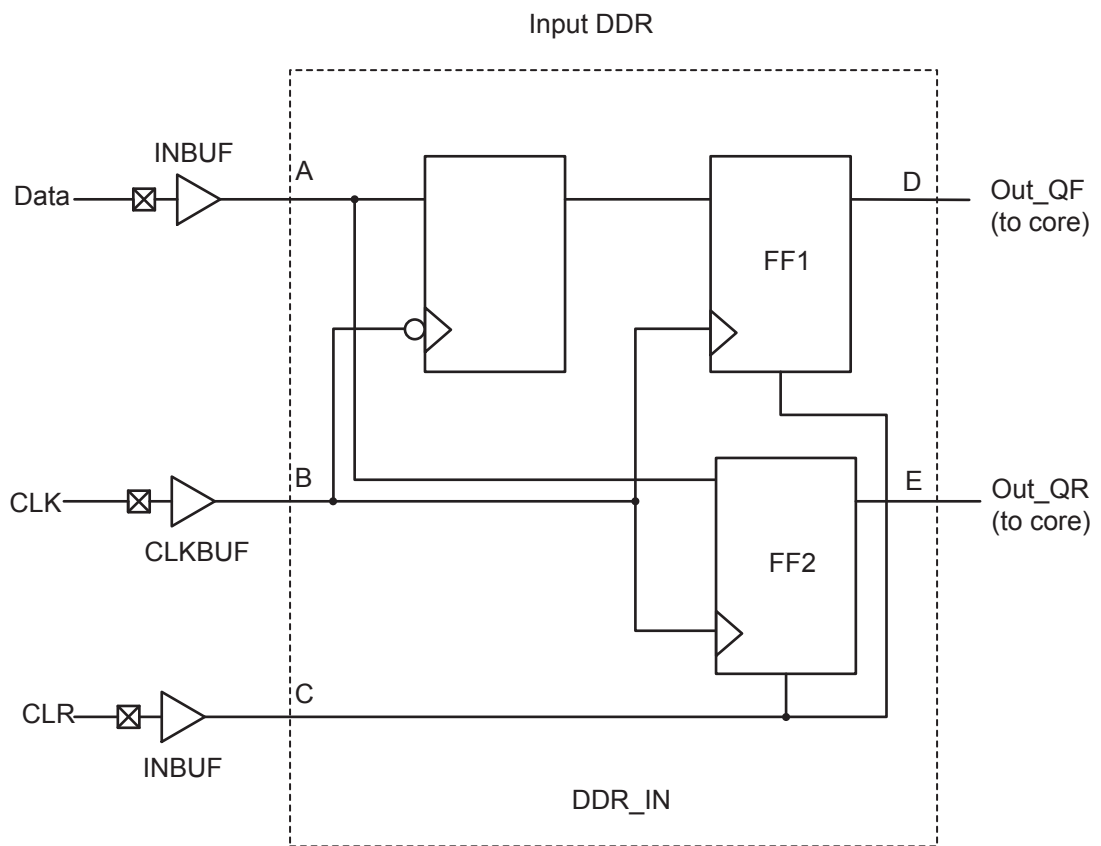
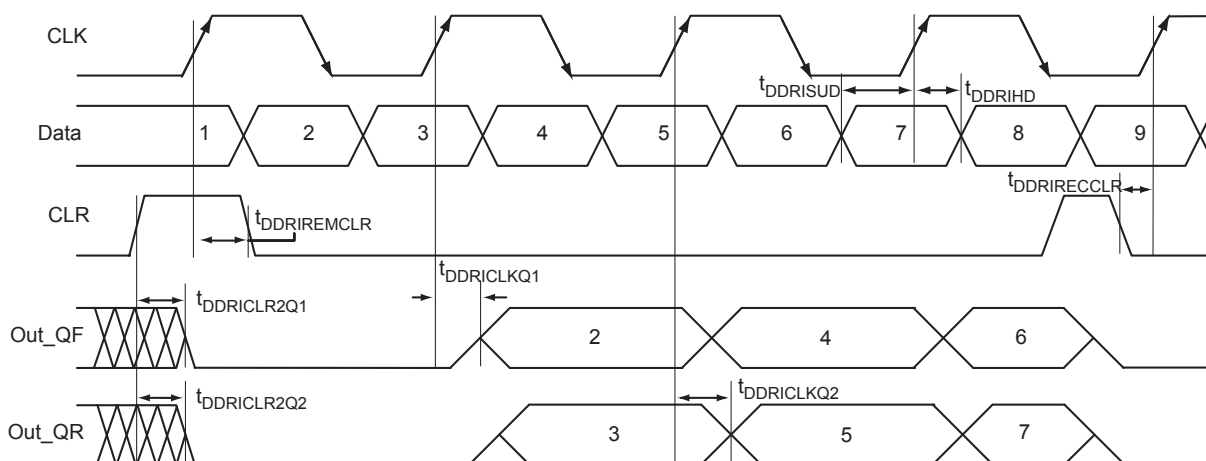

Figure 2-20 • Input DDR Timing Model

Table 2-98 • Parameter Definitions

Parameter Name	Parameter Definition	Measuring Nodes (from, to)
$t_{DDRICKQ1}$	Clock-to-Out Out_QR	B, D
$t_{DDRICKQ2}$	Clock-to-Out Out_QF	B, E
$t_{DDRISUD}$	Data Setup Time of DDR Input	A, B
t_{DDRILD}	Data Hold Time of DDR Input	A, B
$t_{DDRICLR2Q1}$	Clear-to-Out Out_QR	C, D
$t_{DDRICLR2Q2}$	Clear-to-Out Out_QF	C, E
$t_{DDRIREMCLR}$	Clear Removal	C, B
$t_{DDRIRECCLR}$	Clear Recovery	C, B

Figure 2-21 • Input DDR Timing Diagram

Timing Characteristics

Table 2-99 • Input DDR Propagation Delays

 Automotive-Case Conditions: $T_J = 135^{\circ}\text{C}$, Worst-Case $V_{CC} = 1.425\text{ V}$

Parameter	Description	-1	Std.	Units
t_{DDRICKQ1}	Clock-to-Out Out_QR for Input DDR	0.33	0.39	ns
t_{DDRICKQ2}	Clock-to-Out Out_QF for Input DDR	0.47	0.56	ns
t_{DDRISUD}	Data Setup for Input DDR	0.34	0.40	ns
t_{DDRIHD}	Data Hold for Input DDR	0.00	0.00	ns
$t_{\text{DDRICLR2Q1}}$	Asynchronous Clear-to-Out Out_QR for Input DDR	0.56	0.66	ns
$t_{\text{DDRICLR2Q2}}$	Asynchronous Clear-to-Out Out_QF for Input DDR	0.69	0.82	ns
$t_{\text{DDRIREMCLR}}$	Asynchronous Clear Removal Time for Input DDR	0.00	0.00	ns
$t_{\text{DDRIRECCLR}}$	Asynchronous Clear Recovery Time for Input DDR	0.27	0.32	ns
t_{DDRiWCLR}	Asynchronous Clear Minimum Pulse Width for Input DDR	0.25	0.30	ns
$t_{\text{DDRICKMPWH}}$	Clock Minimum Pulse Width High for Input DDR	0.41	0.48	ns
$t_{\text{DDRICKMPWL}}$	Clock Minimum Pulse Width Low for Input DDR	0.37	0.43	ns
F_{DDRIMAX}	Maximum Frequency for Input DDR	309	263	MHz

Note: For specific junction temperature and voltage supply levels, refer to Table 2-5 on page 2-5 for derating values.

Table 2-100 • Input DDR Propagation Delays
Automotive-Case Conditions: $T_J = 115^\circ\text{C}$, Worst-Case $V_{CC} = 1.425\text{ V}$

Parameter	Description	-1	Std.	Units
t_{DDRICKQ1}	Clock-to-Out Out_QR for Input DDR	0.33	0.38	ns
t_{DDRICKQ2}	Clock-to-Out Out_QF for Input DDR	0.46	0.54	ns
t_{DDRISUD}	Data Setup for Input DDR	0.34	0.40	ns
t_{DDRILD}	Data Hold for Input DDR	0.00	0.00	ns
$t_{\text{DDRILR2Q1}}$	Asynchronous Clear-to-Out Out_QR for Input DDR	0.55	0.65	ns
$t_{\text{DDRILR2Q2}}$	Asynchronous Clear-to-Out Out_QF for Input DDR	0.68	0.80	ns
$t_{\text{DDRIREMCLR}}$	Asynchronous Clear Removal Time for Input DDR	0.00	0.00	ns
$t_{\text{DDRIRECCLR}}$	Asynchronous Clear Recovery Time for Input DDR	0.27	0.31	ns
$t_{\text{DDRILWCLR}}$	Asynchronous Clear Minimum Pulse Width for Input DDR	0.25	0.30	ns
$t_{\text{DDRICKMPWH}}$	Clock Minimum Pulse Width High for Input DDR	0.41	0.48	ns
$t_{\text{DDRICKMPWL}}$	Clock Minimum Pulse Width Low for Input DDR	0.37	0.43	ns
F_{DDRIMAX}	Maximum Frequency for Input DDR	309	263	MHz

Note: For specific junction temperature and voltage supply levels, refer to [Table 2-5 on page 2-5](#) for derating values.

Output DDR Module

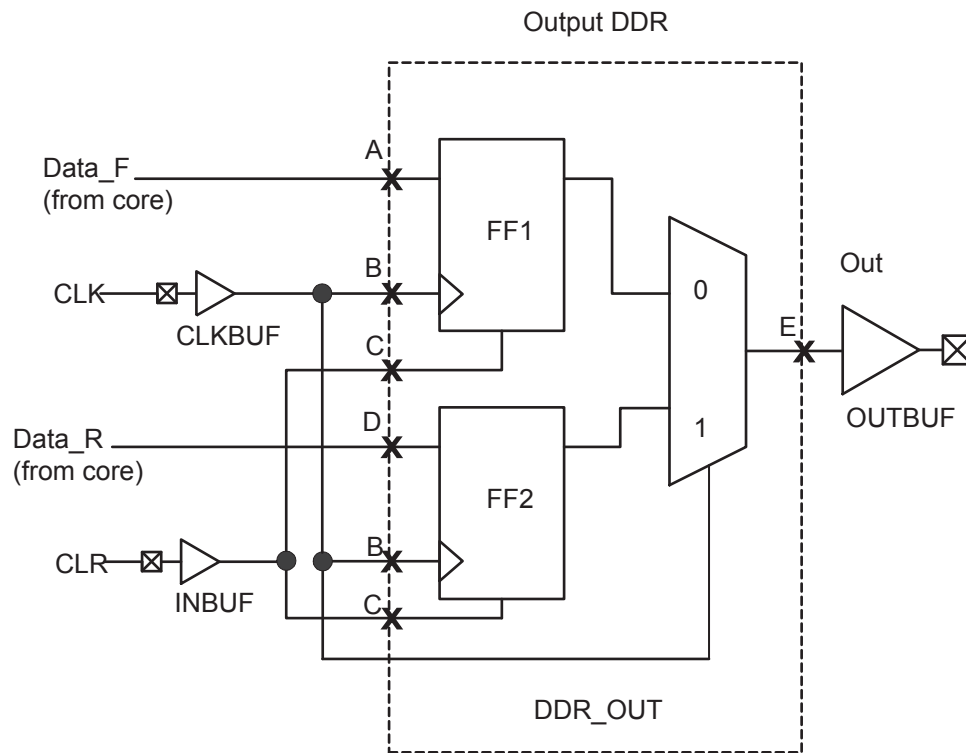
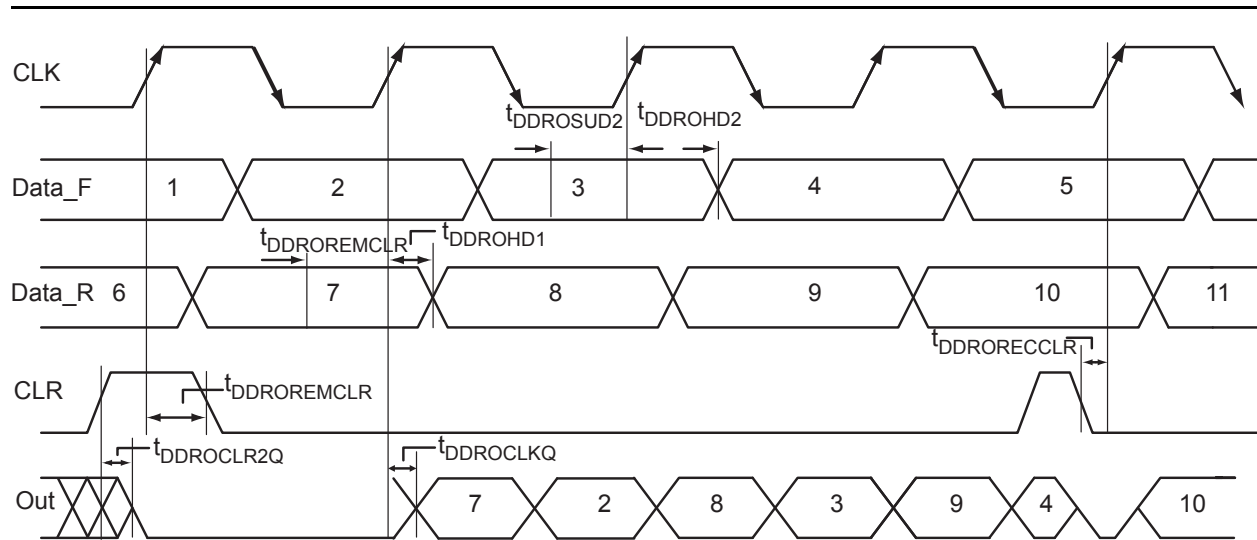

Figure 2-22 • Output DDR Timing Model

Table 2-101 • Parameter Definitions

Parameter Name	Parameter Definition	Measuring Nodes (from, to)
$t_{DDROCLKQ}$	Clock-to-Out	B, E
$t_{DDROCLR2Q}$	Asynchronous Clear-to-Out	C, E
$t_{DDROEMCLR}$	Clear Removal	C, B
$t_{DDROECCLR}$	Clear Recovery	C, B
$t_{DDROSUD1}$	Data Setup Data_F	A, B
$t_{DDROSUD2}$	Data Setup Data_R	D, B
$t_{DDROHD1}$	Data Hold Data_F	A, B
$t_{DDROHD2}$	Data Hold Data_R	D, B

Figure 2-23 • Output DDR Timing Diagram

Timing Characteristics

Table 2-102 • Output DDR Propagation Delays

 Commercial-Case Conditions: $T_J = 135^{\circ}\text{C}$, Worst-Case $V_{CC} = 1.425\text{ V}$

Parameter	Description	-1	Std.	Units
t_{DDROCLKQ}	Clock-to-Out of DDR for Output DDR	0.85	1.00	ns
t_{DDROSUD1}	Data_F Data Setup for Output DDR	0.46	0.54	ns
t_{DDROSUD2}	Data_R Data Setup for Output DDR	0.46	0.54	ns
t_{DDROHD1}	Data_F Data Hold for Output DDR	0.00	0.00	ns
t_{DDROHD2}	Data_R Data Hold for Output DDR	0.00	0.00	ns
$t_{\text{DDROCLR2Q}}$	Asynchronous Clear-to-Out for Output DDR	0.97	1.15	ns
$t_{\text{DDROEMCLR}}$	Asynchronous Clear Removal Time for Output DDR	0.00	0.00	ns
$t_{\text{DDROECCLR}}$	Asynchronous Clear Recovery Time for Output DDR	0.27	0.32	ns
$t_{\text{DDROWCLR1}}$	Asynchronous Clear Minimum Pulse Width for Output DDR	0.25	0.30	ns
$t_{\text{DDROCKMPWH}}$	Clock Minimum Pulse Width High for the Output DDR	0.41	0.48	ns
$t_{\text{DDROCKMPWL}}$	Clock Minimum Pulse Width Low for the Output DDR	0.37	0.43	ns
F_{DDOMAX}	Maximum Frequency for the Output DDR	309	263	MHz

Note: For specific junction temperature and voltage supply levels, refer to Table 2-5 on page 2-5 for derating values.

Table 2-103 • Output DDR Propagation Delays
Commercial-Case Conditions: $T_J = 115^\circ\text{C}$, Worst-Case $V_{CC} = 1.425\text{ V}$

Parameter	Description	-1	Std.	Units
t_{DDROCLKQ}	Clock-to-Out of DDR for Output DDR	0.84	0.98	ns
t_{DDROSUD1}	Data_F Data Setup for Output DDR	0.45	0.53	ns
t_{DDROSUD2}	Data_R Data Setup for Output DDR	0.45	0.53	ns
t_{DDROHD1}	Data_F Data Hold for Output DDR	0.00	0.00	ns
t_{DDROHD2}	Data_R Data Hold for Output DDR	0.00	0.00	ns
$t_{\text{DDROCLR2Q}}$	Asynchronous Clear-to-Out for Output DDR	0.96	1.12	ns
$t_{\text{DDROREMCLR}}$	Asynchronous Clear Removal Time for Output DDR	0.00	0.00	ns
$t_{\text{DDRORECCLR}}$	Asynchronous Clear Recovery Time for Output DDR	0.27	0.31	ns
$t_{\text{DDROWCLR1}}$	Asynchronous Clear Minimum Pulse Width for Output DDR	0.25	0.30	ns
$t_{\text{DDROCKMPWH}}$	Clock Minimum Pulse Width High for the Output DDR	0.41	0.48	ns
$t_{\text{DDROCKMPWL}}$	Clock Minimum Pulse Width Low for the Output DDR	0.37	0.43	ns
F_{DDOMAX}	Maximum Frequency for the Output DDR	309	263	MHz

Note: For specific junction temperature and voltage supply levels, refer to [Table 2-5 on page 2-5](#) for derating values.

VersaTile Characteristics

VersaTile Specifications as a Combinatorial Module

The ProASIC3 library offers all combinations of LUT-3 combinatorial functions. In this section, timing characteristics are presented for a sample of the library. For more details, refer to the *Fusion, IGLOO/e, and ProASIC3/E Macro Library Guide*.

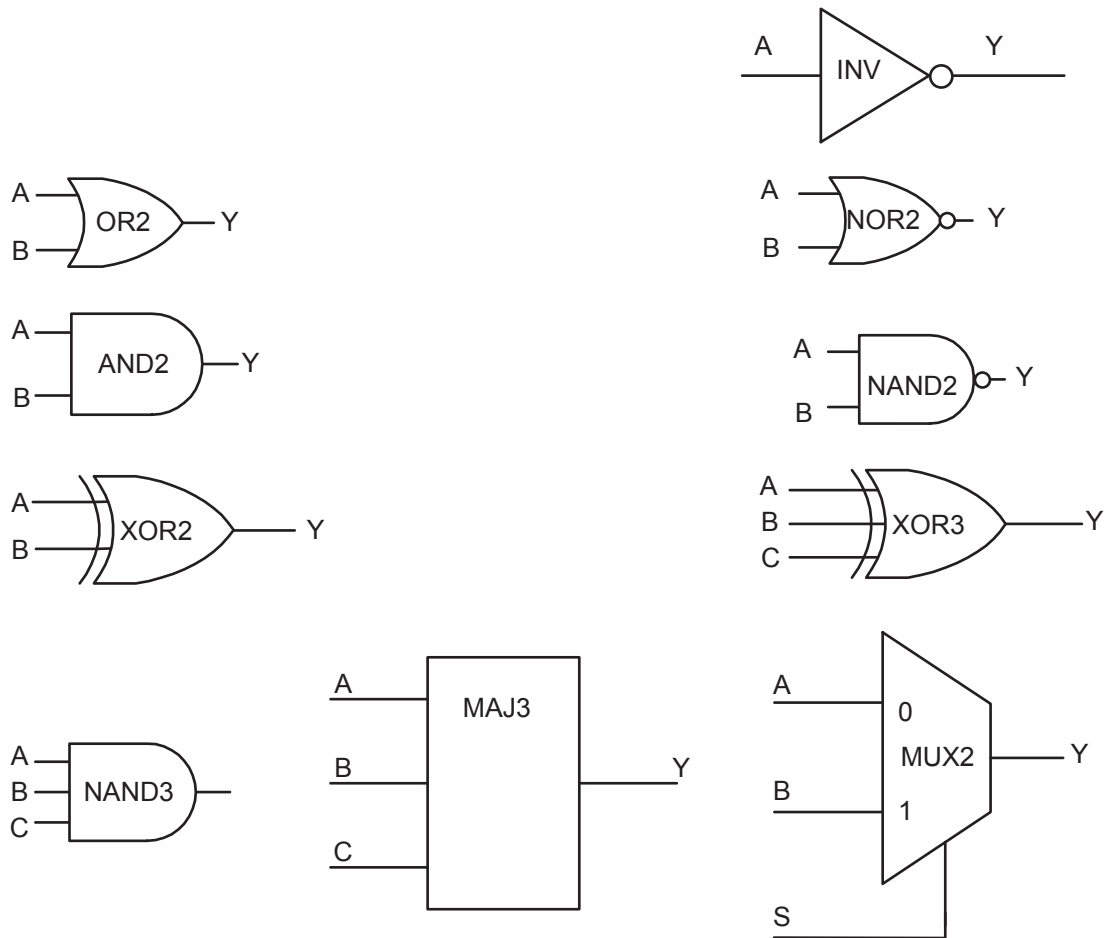
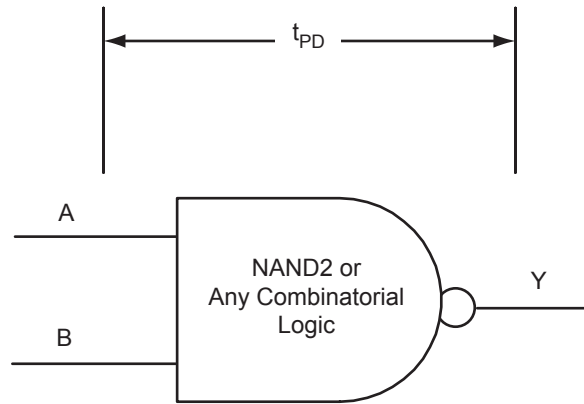

Figure 2-24 • Sample of Combinatorial Cells



$t_{PD} = \text{MAX}(t_{PD(RR)}, t_{PD(RF)}, t_{PD(FF)}, t_{PD(FR)})$
 where edges are applicable for the particular combinatorial cell

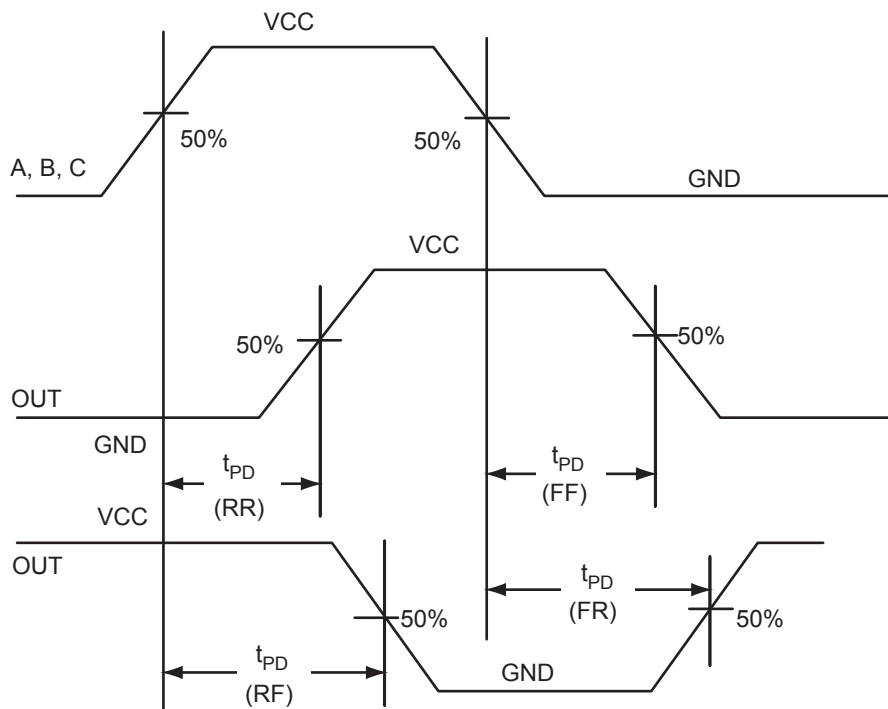

Figure 2-25 • Timing Model and Waveforms

Timing Characteristics

Table 2-104 • Combinatorial Cell Propagation Delays
Automotive-Case Conditions: $T_j = 135^\circ\text{C}$, Worst-Case VCC = 1.425 V

Combinatorial Cell	Equation	Parameter	-1	Std.	Units
INV	$Y = !A$	t_{PD}	0.49	0.57	ns
AND2	$Y = A \cdot B$	t_{PD}	0.57	0.67	ns
NAND2	$Y = !(A \cdot B)$	t_{PD}	0.57	0.67	ns
OR2	$Y = A + B$	t_{PD}	0.59	0.69	ns
NOR2	$Y = !(A + B)$	t_{PD}	0.59	0.69	ns
XOR2	$Y = A \oplus B$	t_{PD}	0.90	1.05	ns
MAJ3	$Y = \text{MAJ}(A, B, C)$	t_{PD}	0.85	1.00	ns
XOR3	$Y = A \oplus B \oplus C$	t_{PD}	1.06	1.25	ns
MUX2	$Y = A !S + B S$	t_{PD}	0.62	0.72	ns
AND3	$Y = A \cdot B \cdot C$	t_{PD}	0.68	0.80	ns

Note: For specific junction temperature and voltage supply levels, refer to [Table 2-5 on page 2-5](#) for derating values.

Table 2-105 • Combinatorial Cell Propagation Delays
Automotive-Case Conditions: $T_j = 115^\circ\text{C}$, Worst-Case VCC = 1.425 V

Combinatorial Cell	Equation	Parameter	-1	Std.	Units
INV	$Y = !A$	t_{PD}	0.48	0.56	ns
AND2	$Y = A \cdot B$	t_{PD}	0.56	0.66	ns
NAND2	$Y = !(A \cdot B)$	t_{PD}	0.56	0.66	ns
OR2	$Y = A + B$	t_{PD}	0.58	0.68	ns
NOR2	$Y = !(A + B)$	t_{PD}	0.58	0.68	ns
XOR2	$Y = A \oplus B$	t_{PD}	0.88	1.03	ns
MAJ3	$Y = \text{MAJ}(A, B, C)$	t_{PD}	0.83	0.98	ns
XOR3	$Y = A \oplus B \oplus C$	t_{PD}	1.04	1.23	ns
MUX2	$Y = A !S + B S$	t_{PD}	0.60	0.71	ns
AND3	$Y = A \cdot B \cdot C$	t_{PD}	0.67	0.79	ns

Note: For specific junction temperature and voltage supply levels, refer to [Table 2-5 on page 2-5](#) for derating values.

VersaTile Specifications as a Sequential Module

The ProASIC3 library offers a wide variety of sequential cells, including flip-flops and latches. Each has a data input and optional enable, clear, or preset. In this section, timing characteristics are presented for a representative sample from the library. For more details, refer to the [Fusion](#), [IGLOO/e](#) and [ProASIC3/E Macro Library Guide](#).

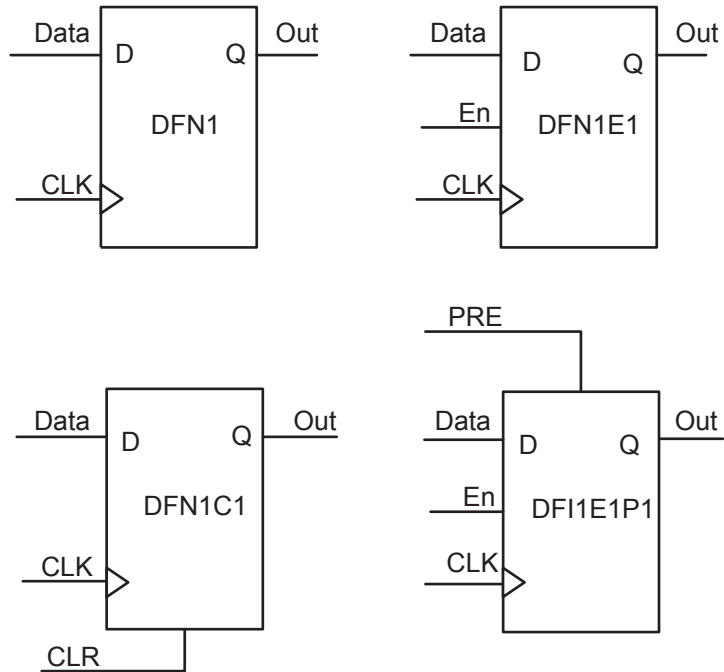
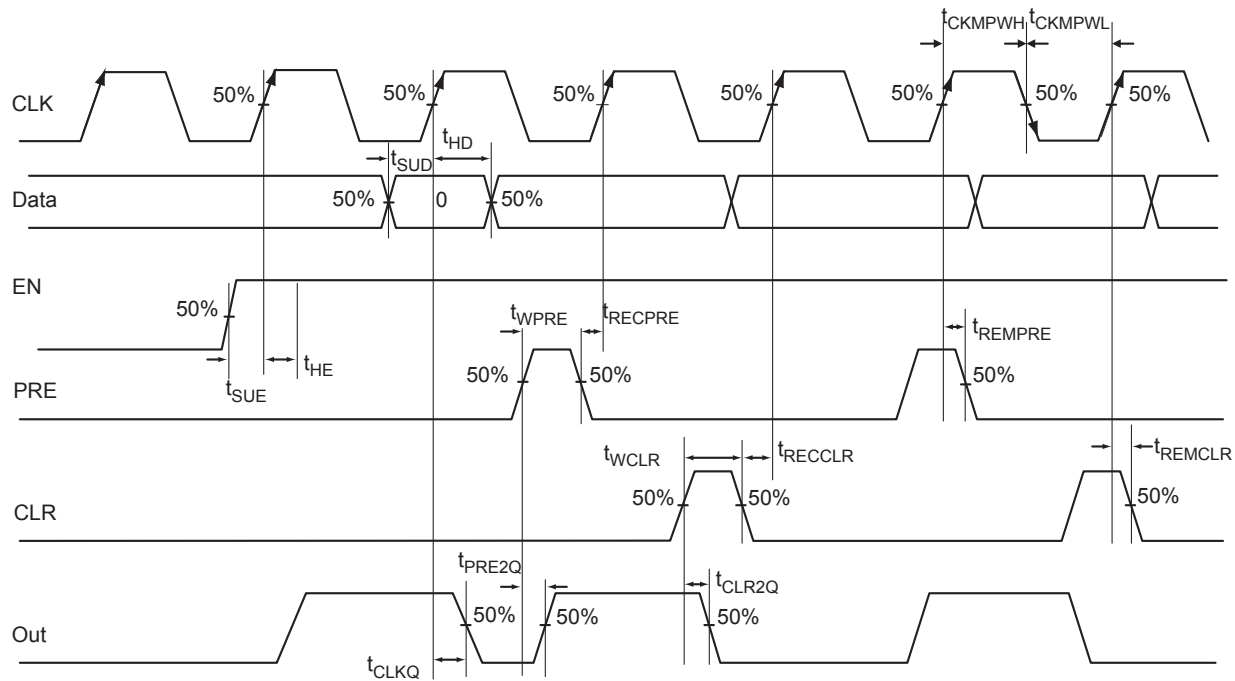

Figure 2-26 • Sample of Sequential Cells

Figure 2-27 • Timing Model and Waveforms

Timing Characteristics

Table 2-106 • Register Delays

 Automotive-Case Conditions: $T_J = 135^\circ\text{C}$, Worst-Case $V_{CC} = 1.425\text{ V}$

Parameter	Description	-1	Std.	Units
t_{CLKQ}	Clock-to-Q of the Core Register	0.67	0.79	ns
t_{SUD}	Data Setup Time for the Core Register	0.52	0.61	ns
t_{HD}	Data Hold Time for the Core Register	0.00	0.00	ns
t_{SUE}	Enable Setup Time for the Core Register	0.55	0.65	ns
t_{HE}	Enable Hold Time for the Core Register	0.00	0.00	ns
t_{CLR2Q}	Asynchronous Clear-to-Q of the Core Register	0.49	0.57	ns
t_{PRE2Q}	Asynchronous Preset-to-Q of the Core Register	0.49	0.57	ns
t_{REMCLR}	Asynchronous Clear Removal Time for the Core Register	0.00	0.00	ns
t_{RECCLR}	Asynchronous Clear Recovery Time for the Core Register	0.27	0.32	ns
t_{REMPRE}	Asynchronous Preset Removal Time for the Core Register	0.00	0.00	ns
t_{RECPRE}	Asynchronous Preset Recovery Time for the Core Register	0.27	0.32	ns
t_{WCLR}	Asynchronous Clear Minimum Pulse Width for the Core Register	0.25	0.30	ns
t_{WPRE}	Asynchronous Preset Minimum Pulse Width for the Core Register	0.25	0.30	ns
t_{CKMPWH}	Clock Minimum Pulse Width High for the Core Register	0.41	0.48	ns
t_{CKMPWL}	Clock Minimum Pulse Width Low for the Core Register	0.37	0.43	ns

Note: For specific junction temperature and voltage supply levels, refer to Table 2-5 on page 2-5 for derating values.

Table 2-107 • Register Delays
Automotive-Case Conditions: $T_J = 115^\circ\text{C}$, Worst-Case $V_{CC} = 1.425\text{ V}$

Parameter	Description	-1	Std.	Units
t_{CLKQ}	Clock-to-Q of the Core Register	0.66	0.77	ns
t_{SUD}	Data Setup Time for the Core Register	0.51	0.60	ns
t_{HD}	Data Hold Time for the Core Register	0.00	0.00	ns
t_{SUE}	Enable Setup Time for the Core Register	0.54	0.64	ns
t_{HE}	Enable Hold Time for the Core Register	0.00	0.00	ns
t_{CLR2Q}	Asynchronous Clear-to-Q of the Core Register	0.48	0.56	ns
t_{PRE2Q}	Asynchronous Preset-to-Q of the Core Register	0.48	0.56	ns
t_{REMCLR}	Asynchronous Clear Removal Time for the Core Register	0.00	0.00	ns
t_{RECLR}	Asynchronous Clear Recovery Time for the Core Register	0.27	0.31	ns
t_{REMPRE}	Asynchronous Preset Removal Time for the Core Register	0.00	0.00	ns
t_{RECPRE}	Asynchronous Preset Recovery Time for the Core Register	0.27	0.31	ns
t_{WCLR}	Asynchronous Clear Minimum Pulse Width for the Core Register	0.25	0.30	ns
t_{WPRE}	Asynchronous Preset Minimum Pulse Width for the Core Register	0.25	0.30	ns
t_{CKMPWH}	Clock Minimum Pulse Width High for the Core Register	0.41	0.48	ns
t_{CKMPWL}	Clock Minimum Pulse Width Low for the Core Register	0.37	0.43	ns

Note: For specific junction temperature and voltage supply levels, refer to [Table 2-5 on page 2-5](#) for derating values.

Global Resource Characteristics

A3P250 Clock Tree Topology

Clock delays are device-specific. Figure 2-28 is an example of a global tree used for clock routing. The global tree presented in Figure 2-28 is driven by a CCC located on the west side of the A3P250 device. It is used to drive all D-flip-flops in the device.

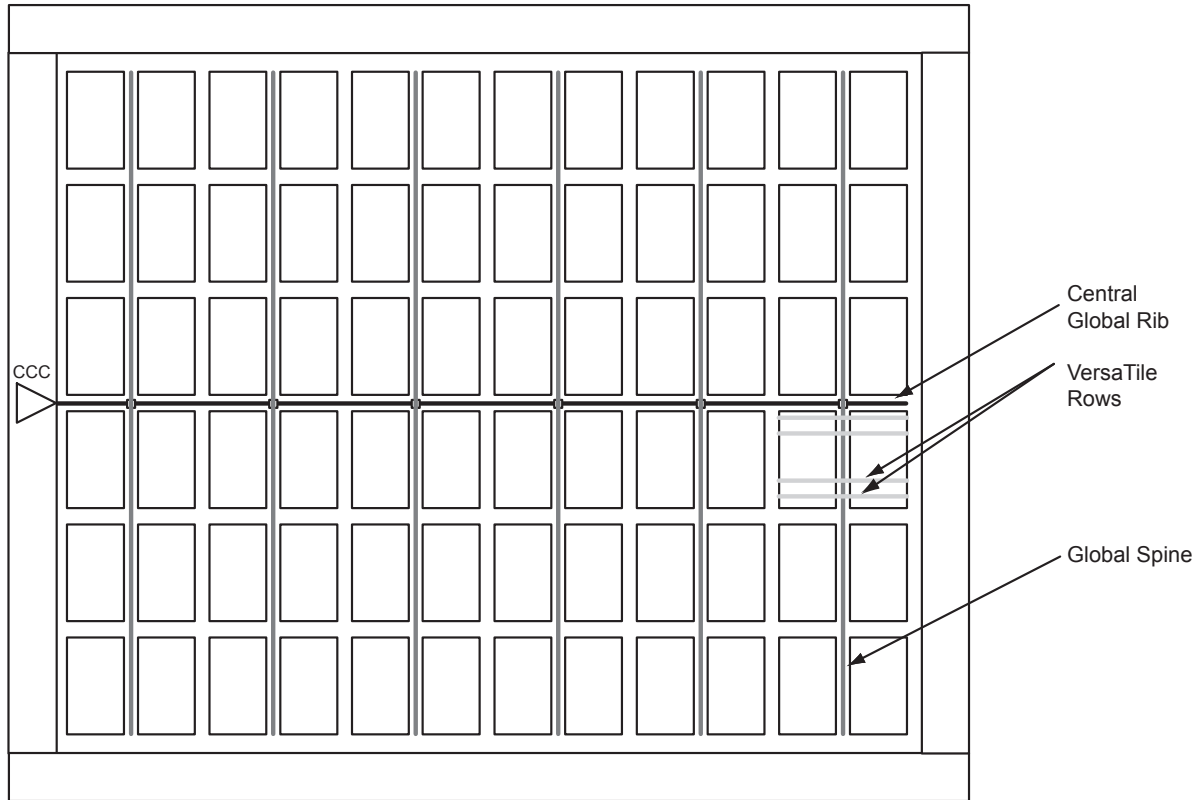

Figure 2-28 • Example of Global Tree Use in an A3P250 Device for Clock Routing

Global Tree Timing Characteristics

Global clock delays include the central rib delay, the spine delay, and the row delay. Delays do not include I/O input buffer clock delays, as these are I/O standard-dependent, and the clock may be driven and conditioned internally by the CCC module. For more details on clock conditioning capabilities, refer to the "Clock Conditioning Circuits" section on page 2-80. Table 2-114 on page 2-79 to Table 2-125 on page 2-97 present minimum and maximum global clock delays within each device. Minimum and maximum delays are measured with minimum and maximum loading.

Timing Characteristics

Table 2-108 • A3P060 Global Resource
 Commercial-Case Conditions: $T_J = 135^\circ\text{C}$, $V_{CC} = 1.425\text{ V}$

Parameter	Description	-1		Std.		Units
		Min. ¹	Max. ²	Min. ¹	Max. ²	
t_{RCKL}	Input Low Delay for Global Clock	0.87	1.16	1.02	1.37	ns
t_{RCKH}	Input High Delay for Global Clock	0.86	1.20	1.01	1.42	ns
$t_{RCKMPWH}$	Minimum Pulse Width High for Global Clock	0.80		0.94		ns
$t_{RCKMPWL}$	Minimum Pulse Width Low for Global Clock	0.98		1.15		ns
t_{RCKSW}	Maximum Skew for Global Clock		0.35		0.41	ns

Notes:

1. Value reflects minimum load. The delay is measured from the CCC output to the clock pin of a sequential element, located in a lightly loaded row (single element is connected to the global net).
2. Value reflects maximum load. The delay is measured on the clock pin of the farthest sequential element, located in a fully loaded row (all available flip-flops are connected to the global net in the row).
3. For specific junction temperature and voltage supply levels, refer to Table 2-5 on page 2-5 for derating values.

Table 2-109 • A3P060 Global Resource
 Commercial-Case Conditions: $T_J = 115^\circ\text{C}$, $V_{CC} = 1.425\text{ V}$

Parameter	Description	-1		Std.		Units
		Min. ¹	Max. ²	Min. ¹	Max. ²	
t_{RCKL}	Input Low Delay for Global Clock	0.85	1.13	1.00	1.33	ns
t_{RCKH}	Input High Delay for Global Clock	0.84	1.18	0.99	1.38	ns
$t_{RCKMPWH}$	Minimum Pulse Width High for Global Clock	0.80		0.94		ns
$t_{RCKMPWL}$	Minimum Pulse Width Low for Global Clock	0.98		1.15		ns
t_{RCKSW}	Maximum Skew for Global Clock		0.34		0.40	ns

Notes:

1. Value reflects minimum load. The delay is measured from the CCC output to the clock pin of a sequential element, located in a lightly loaded row (single element is connected to the global net).
2. Value reflects maximum load. The delay is measured on the clock pin of the farthest sequential element, located in a fully loaded row (all available flip-flops are connected to the global net in the row).
3. For specific junction temperature and voltage supply levels, refer to Table 2-5 on page 2-5 for derating values.

Table 2-110 • A3P125 Global Resource
 Commercial-Case Conditions: $T_J = 135^\circ\text{C}$, $V_{CC} = 1.425\text{ V}$

Parameter	Description	-1		Std.		Units
		Min. ¹	Max. ²	Min. ¹	Max. ²	
t_{RCKL}	Input Low Delay for Global Clock	0.93	1.22	1.09	1.43	ns
t_{RCKH}	Input High Delay for Global Clock	0.92	1.26	1.08	1.49	ns
$t_{RCKMPWH}$	Minimum Pulse Width High for Global Clock	0.80		0.94		ns
$t_{RCKMPWL}$	Minimum Pulse Width Low for Global Clock	0.98		1.15		ns
t_{RCKSW}	Maximum Skew for Global Clock		0.35		0.41	ns

Notes:

1. Value reflects minimum load. The delay is measured from the CCC output to the clock pin of a sequential element, located in a lightly loaded row (single element is connected to the global net).
2. Value reflects maximum load. The delay is measured on the clock pin of the farthest sequential element, located in a fully loaded row (all available flip-flops are connected to the global net in the row).
3. For specific junction temperature and voltage supply levels, refer to [Table 2-5 on page 2-5](#) for derating values.

Table 2-111 • A3P125 Global Resource
 Commercial-Case Conditions: $T_J = 115^\circ\text{C}$, $V_{CC} = 1.425\text{ V}$

Parameter	Description	-1		Std.		Units
		Min. ¹	Max. ²	Min. ¹	Max. ²	
t_{RCKL}	Input Low Delay for Global Clock	0.90	1.19	1.06	1.40	ns
t_{RCKH}	Input High Delay for Global Clock	0.90	1.23	1.05	1.45	ns
$t_{RCKMPWH}$	Minimum Pulse Width High for Global Clock	0.80		0.94		ns
$t_{RCKMPWL}$	Minimum Pulse Width Low for Global Clock	0.98		1.15		ns
t_{RCKSW}	Maximum Skew for Global Clock		0.34		0.40	ns

Notes:

1. Value reflects minimum load. The delay is measured from the CCC output to the clock pin of a sequential element, located in a lightly loaded row (single element is connected to the global net).
2. Value reflects maximum load. The delay is measured on the clock pin of the farthest sequential element, located in a fully loaded row (all available flip-flops are connected to the global net in the row).
3. For specific junction temperature and voltage supply levels, refer to [Table 2-5 on page 2-5](#) for derating values.

Table 2-112 • A3P250 Global Resource
 Commercial-Case Conditions: $T_J = 135^{\circ}\text{C}$, $V_{CC} = 1.425\text{ V}$

Parameter	Description	-1		Std.		Units
		Min. ¹	Max. ²	Min. ¹	Max. ²	
t_{RCKL}	Input Low Delay for Global Clock	0.96	1.25	1.13	1.47	ns
t_{RCKH}	Input High Delay for Global Clock	0.94	1.28	1.10	1.51	ns
$t_{RCKMPWH}$	Minimum Pulse Width High for Global Clock	0.80		0.94		ns
$t_{RCKMPWL}$	Minimum Pulse Width Low for Global Clock	0.98		1.15		ns
t_{RCKSW}	Maximum Skew for Global Clock		0.35		0.41	ns

Notes:

1. Value reflects minimum load. The delay is measured from the CCC output to the clock pin of a sequential element, located in a lightly loaded row (single element is connected to the global net).
2. Value reflects maximum load. The delay is measured on the clock pin of the farthest sequential element, located in a fully loaded row (all available flip-flops are connected to the global net in the row).
3. For specific junction temperature and voltage supply levels, refer to [Table 2-5 on page 2-5](#) for derating values.

Table 2-113 • A3P250 Global Resource
 Commercial-Case Conditions: $T_J = 115^{\circ}\text{C}$, $V_{CC} = 1.425\text{ V}$

Parameter	Description	-1		Std.		Units
		Min. ¹	Max. ²	Min. ¹	Max. ²	
t_{RCKL}	Input Low Delay for Global Clock	0.94	1.22	1.10	1.44	ns
t_{RCKH}	Input High Delay for Global Clock	0.92	1.25	1.08	1.47	ns
$t_{RCKMPWH}$	Minimum Pulse Width High for Global Clock	0.80		0.94		ns
$t_{RCKMPWL}$	Minimum Pulse Width Low for Global Clock	0.98		1.15		ns
t_{RCKSW}	Maximum Skew for Global Clock		0.34		0.40	ns

Notes:

1. Value reflects minimum load. The delay is measured from the CCC output to the clock pin of a sequential element, located in a lightly loaded row (single element is connected to the global net).
2. Value reflects maximum load. The delay is measured on the clock pin of the farthest sequential element, located in a fully loaded row (all available flip-flops are connected to the global net in the row).
3. For specific junction temperature and voltage supply levels, refer to [Table 2-5 on page 2-5](#) for derating values.

Table 2-114 • A3P1000 Global Resource
 Automotive-Case Conditions: $T_J = 135^\circ\text{C}$, $V_{CC} = 1.425\text{ V}$

Parameter	Description	-1		Std.		Units
		Min. ¹	Max. ²	Min. ¹	Max. ²	
t_{RCKL}	Input Low Delay for Global Clock	1.17	1.46	1.37	1.72	ns
t_{RCKH}	Input High Delay for Global Clock	1.15	1.50	1.36	1.76	ns
$t_{RCKMPWH}$	Minimum Pulse Width High for Global Clock	0.80		0.94		ns
$t_{RCKMPWL}$	Minimum Pulse Width Low for Global Clock	0.98		1.15		ns
t_{RCKSW}	Maximum Skew for Global Clock		0.35		0.41	ns

Notes:

1. Value reflects minimum load. The delay is measured from the CCC output to the clock pin of a sequential element, located in a lightly loaded row (single element is connected to the global net).
2. Value reflects maximum load. The delay is measured on the clock pin of the farthest sequential element, located in a fully loaded row (all available flip-flops are connected to the global net in the row).
3. For specific junction temperature and voltage supply levels, refer to [Table 2-5 on page 2-5](#) for derating values.

Table 2-115 • A3P1000 Global Resource
 Automotive-Case Conditions: $T_J = 115^\circ\text{C}$, $V_{CC} = 1.425\text{ V}$

Parameter	Description	-1		Std.		Units
		Min. ¹	Max. ²	Min. ¹	Max. ²	
t_{RCKL}	Input Low Delay for Global Clock	1.14	1.43	1.34	1.68	ns
t_{RCKH}	Input High Delay for Global Clock	1.13	1.46	1.32	1.72	ns
$t_{RCKMPWH}$	Minimum Pulse Width High for Global Clock	0.80		0.94		ns
$t_{RCKMPWL}$	Minimum Pulse Width Low for Global Clock	0.98		1.15		ns
t_{RCKSW}	Maximum Skew for Global Clock		0.34		0.40	ns

Notes:

1. Value reflects minimum load. The delay is measured from the CCC output to the clock pin of a sequential element, located in a lightly loaded row (single element is connected to the global net).
2. Value reflects maximum load. The delay is measured on the clock pin of the farthest sequential element, located in a fully loaded row (all available flip-flops are connected to the global net in the row).
3. For specific junction temperature and voltage supply levels, refer to [Table 2-5 on page 2-5](#) for derating values.

Clock Conditioning Circuits

CCC Electrical Specifications

Timing Characteristics

Table 2-116 • Automotive ProASIC3 CCC/PLL Specification

Parameter	Minimum	Typical	Maximum	Units
Clock Conditioning Circuitry Input Frequency f_{IN_CCC}	1.5		350	MHz
Clock Conditioning Circuitry Output Frequency f_{OUT_CCC}	0.75		350	MHz
Delay Increments in Programmable Delay Blocks ^{1, 2}		160 ³		ps
Number of Programmable Values in Each Programmable Delay Block			32	
Input Period Jitter			1.5	ns
CCC Output Peak-to-Peak Period Jitter F_{CCC_OUT}	Max Peak-to-Peak Period Jitter			
	1 Global Network Used		3 Global Networks Used	
0.75 MHz to 24 MHz	0.50%		0.70%	
24 MHz to 100 MHz	1.00%		1.20%	
100 MHz to 250 MHz	1.75%		2.00%	
250 MHz to 350 MHz	2.50%		5.60%	
Acquisition Time				
(A3P250 and A3P1000 only)	LockControl = 0		300	μs
	LockControl = 1		300	μs
(all other dies)	LockControl = 0		300	μs
	LockControl = 1		6.0	ms
Tracking Jitter ⁴				
(A3P250 and A3P1000 only)	LockControl = 0		1.6	ns
	LockControl = 1		1.6	ns
(all other dies)	LockControl = 0		1.6	ns
	LockControl = 1		0.8	ns
Output Duty Cycle	48.5		51.5	%
Delay Range in Block: Programmable Delay 1 ^{1, 2}	0.6		5.56	ns
Delay Range in Block: Programmable Delay 2 ^{1, 2}	0.025		5.56	ns
Delay Range in Block: Fixed Delay ^{1, 2}		2.2		ns

Notes:

1. This delay is a function of voltage and temperature. See [Table 2-5 on page 2-5](#) for deratings.
2. $T_J = 25^\circ\text{C}$, $V_{CC} = 1.5\text{ V}$
3. When the CCC/PLL core is generated by Microsemi core generator software, not all delay values of the specified delay increments are available. Refer to the [Libero SoC Online Help](#) associated with the core for more information.
4. Tracking jitter is defined as the variation in clock edge position of PLL outputs with reference to the PLL input clock edge. Tracking jitter does not measure the variation in PLL output period, which is covered by the period jitter parameter.

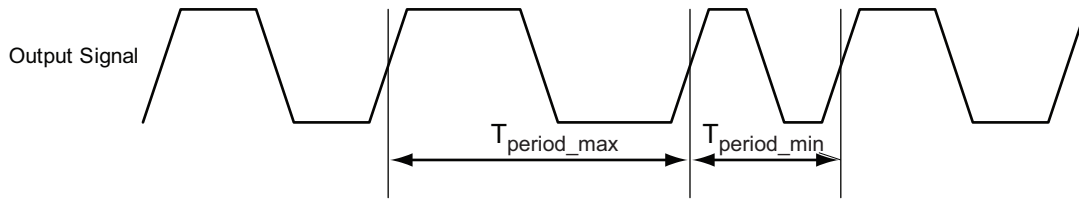

Note: Peak-to-peak jitter measurements are defined by $T_{\text{peak-to-peak}} = T_{\text{period_max}} - T_{\text{period_min}}$.

Figure 2-29 • Peak-to-Peak Jitter Definition

Embedded SRAM and FIFO Characteristics

SRAM

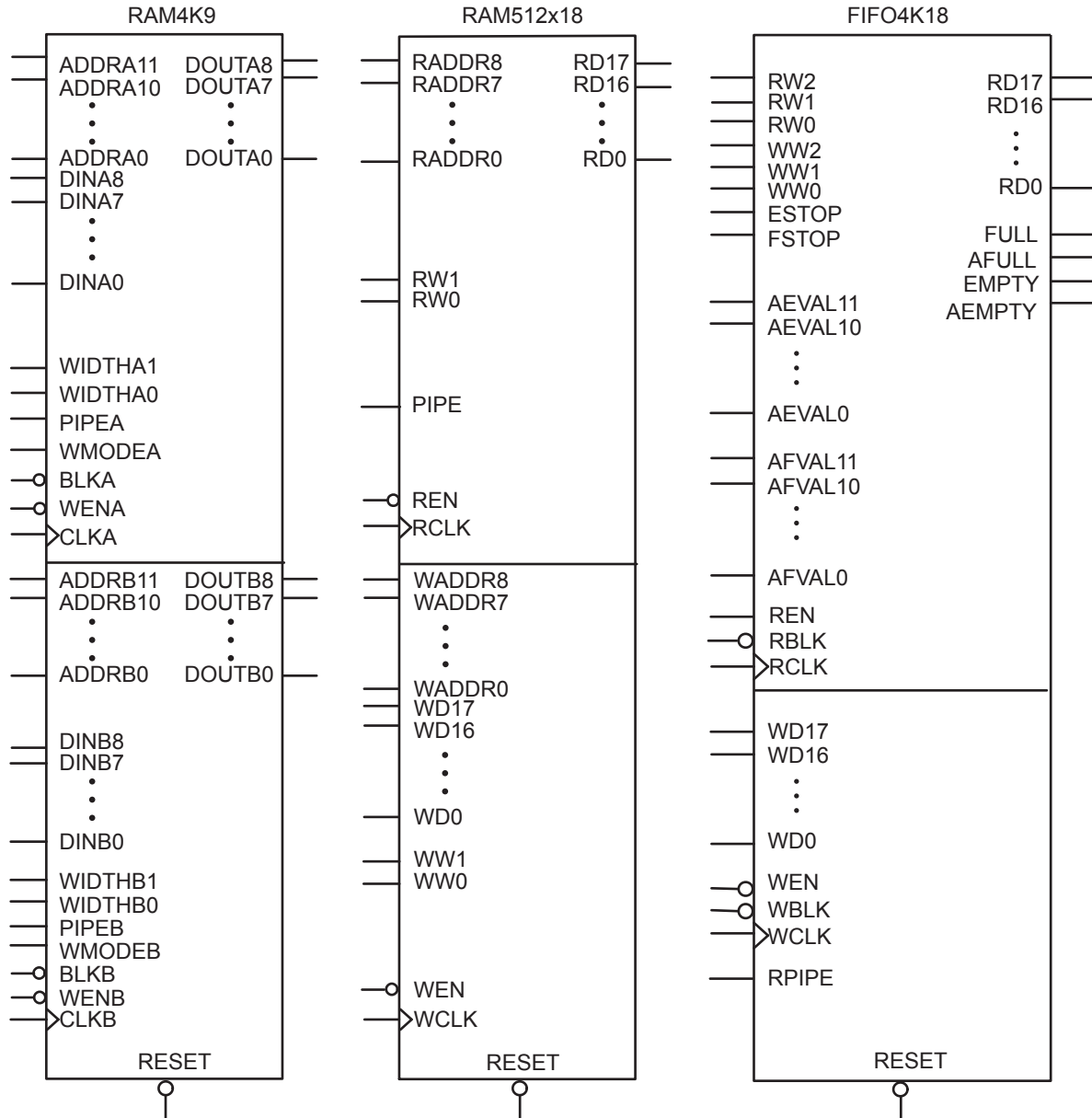

Figure 2-30 • RAM Models

Timing Waveforms

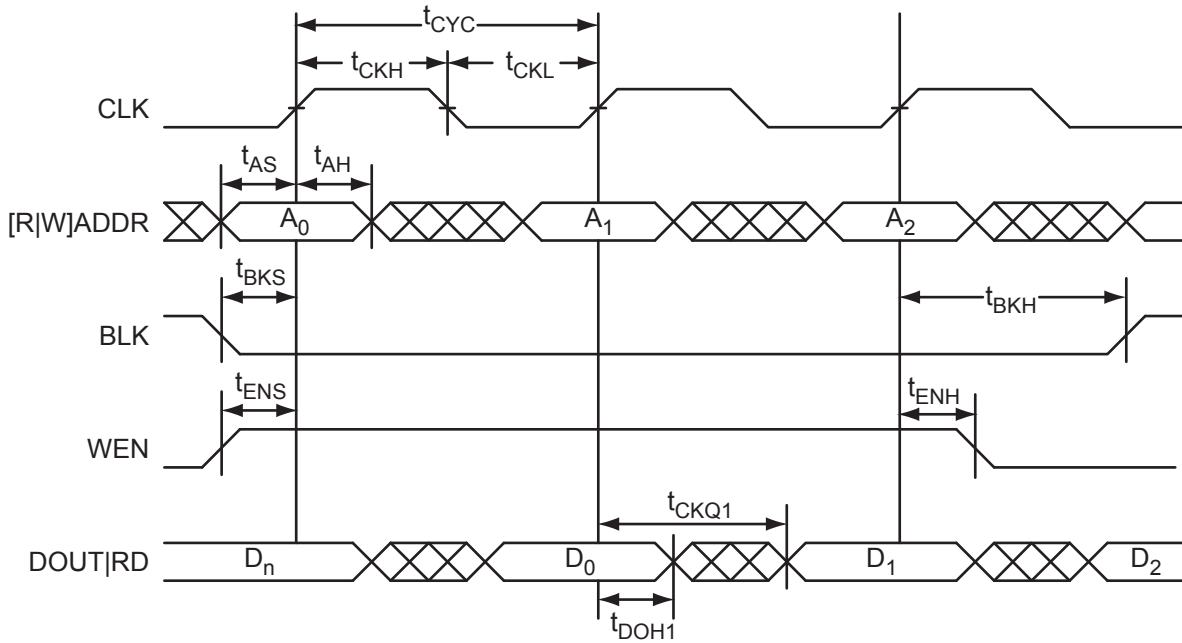

Figure 2-31 • RAM Read for Pass-Through Output. Applicable to Both RAM4K9 and RAM512x18.

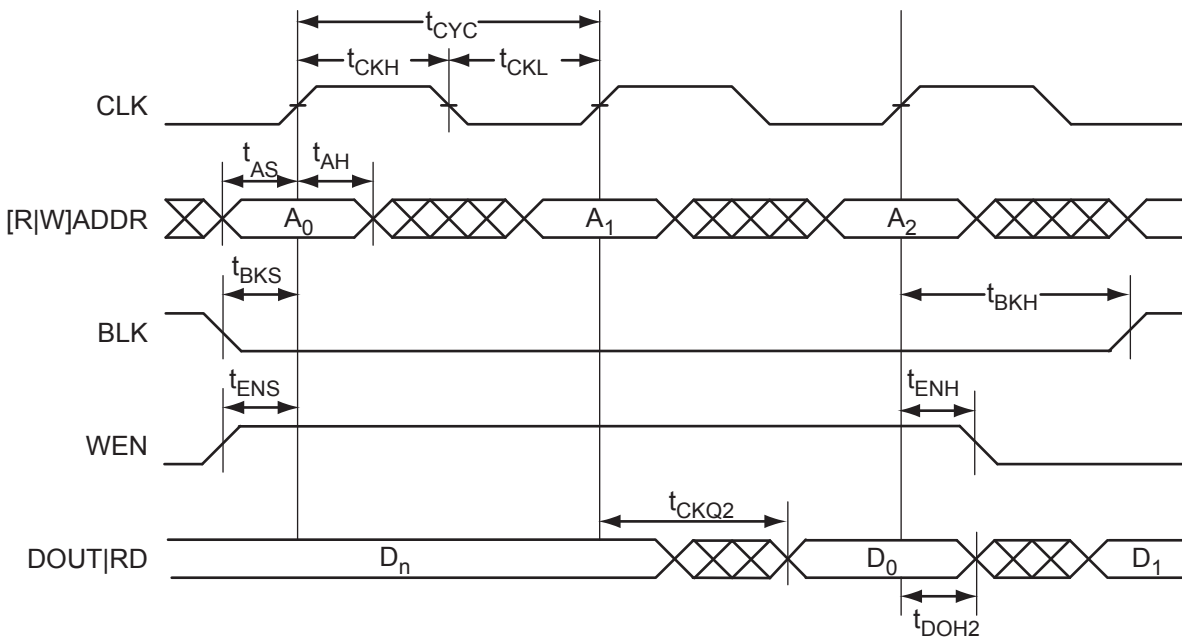

Figure 2-32 • RAM Read for Pipelined Output. Applicable to Both RAM4K9 and RAM512x18.

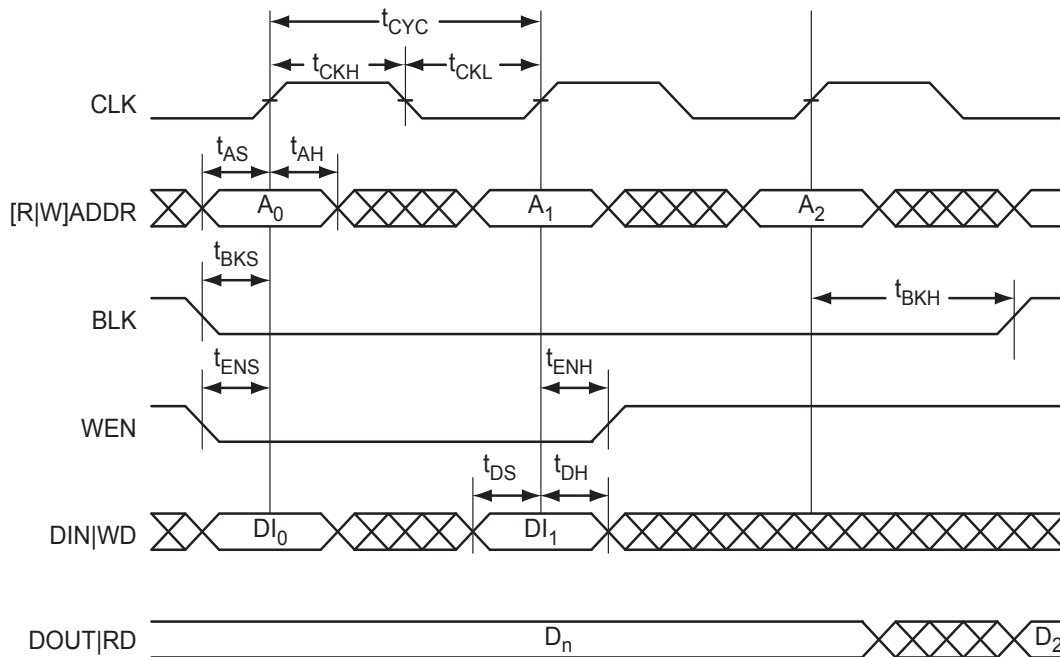

Figure 2-33 • RAM Write, Output Retained. Applicable to Both RAM4K9 and RAM512x18.

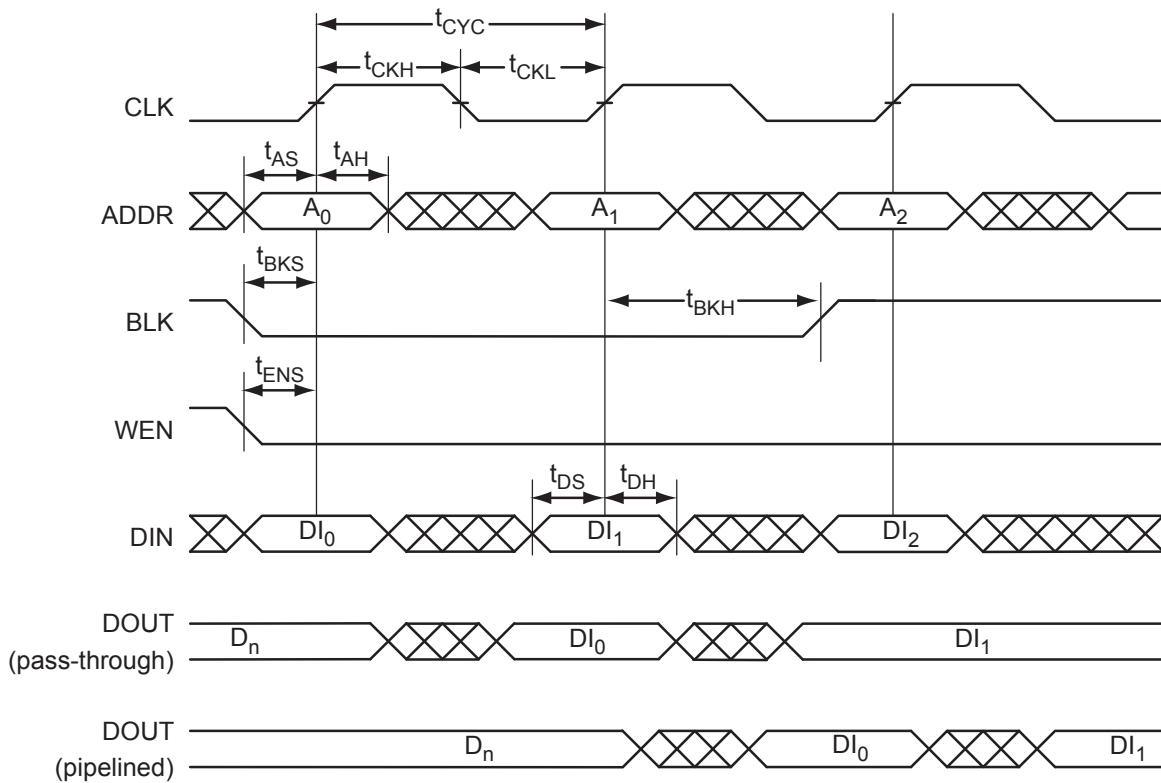

Figure 2-34 • RAM Write, Output as Write Data ($WMODE = 1$). Applicable to RAM4K9 Only.

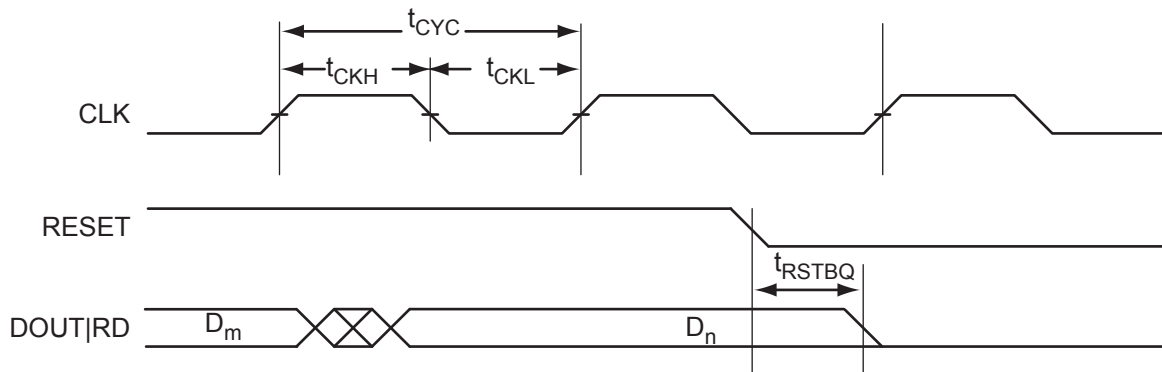

Figure 2-35 • RAM Reset. Applicable to Both RAM4K9 and RAM512x18

Timing Characteristics

Table 2-117 • RAM4K9
Automotive-Case Conditions: $T_J = 135^\circ\text{C}$, Worst-Case $V_{CC} = 1.425\text{ V}$

Parameter	Description	-1	Std.	Units
t_{AS}	Address Setup Time	0.30	0.36	ns
t_{AH}	Address Hold Time	0.00	0.00	ns
t_{ENS}	REN, WEN Setup Time	0.17	0.20	ns
t_{ENH}	REN, WEN Hold Time	0.12	0.14	ns
t_{BKS}	BLK Setup Time	0.28	0.33	ns
t_{BKH}	BLK Hold Time	0.02	0.03	ns
t_{DS}	Input Data (DIN) Setup Time	0.22	0.26	ns
t_{DH}	Input Data (DIN) Hold Time	0.00	0.00	ns
t_{CKQ1}	Clock High to New Data Valid on DOUT (output retained, WMODE = 0)	2.17	2.55	ns
	Clock High to New Data Valid on DOUT (flow-through, WMODE = 1)	2.86	3.37	ns
t_{CKQ2}	Clock High to New Data Valid on DOUT (pipelined)	1.09	1.28	ns
t_{C2CWWL}^1	Address collision clk-to-clk delay for reliable write after write on same address—Applicable to Closing Edge	0.28	0.33	ns
t_{C2CWWH}^1	Address collision clk-to-clk delay for reliable write after write on same address—Applicable to Rising Edge	0.26	0.30	ns
t_{C2CRWH}^1	Address collision clk-to-clk delay for reliable read access after write on same address—Applicable to Opening Edge	0.38	0.45	ns
t_{C2CWRH}^1	Address collision clk-to-clk delay for reliable write access after read on same address—Applicable to Opening Edge	0.42	0.49	ns
t_{RSTBQ}	RESET Low to Data Out Low on DO (flow-through)	1.12	1.32	ns
	RESET Low to Data Out Low on DO (pipelined)	1.12	1.32	ns
$t_{REMRSTB}$	RESET Removal	0.35	0.41	ns
$t_{RECRSTB}$	RESET Recovery	1.82	2.14	ns
$t_{MPWRSTB}$	RESET Minimum Pulse Width	0.26	0.30	ns
t_{CYC}	Clock Cycle Time	3.93	4.62	ns
F_{MAX}	Maximum Frequency	255	217	MHz

Notes:

1. For more information, refer to the application note [Simultaneous Read-Write Operations in Dual-Port SRAM for Flash-Based cSoCs and FPGAs](#).
2. For specific junction temperature and voltage supply levels, refer to [Table 2-5 on page 2-5](#) for derating values.

Table 2-118 • RAM512X18
Automotive-Case Conditions: $T_J = 135^\circ\text{C}$, Worst-Case $V_{CC} = 1.425\text{ V}$

Parameter	Description	-1	Std.	Units
t_{AS}	Address Setup Time	0.30	0.35	ns
t_{AH}	Address Hold Time	0.00	0.00	ns
t_{ENS}	REN, WEN Setup Time	0.11	0.13	ns
t_{ENH}	REN, WEN Hold Time	0.07	0.08	ns
t_{DS}	Input data (WD) Setup Time	0.22	0.26	ns
t_{DH}	Input data (WD) Hold Time	0.00	0.00	ns
t_{CKQ1}	Clock High to New Data Valid on RD (output retained)	2.58	3.03	ns
t_{CKQ2}	Clock High to New Data Valid on RD (pipelined)	1.07	1.26	ns
t_{C2CRWH}^1	Address collision clk-to-clk delay for reliable read access after write on same address—Applicable to Opening Edge	0.43	0.50	ns
t_{C2CWRH}^1	Address collision clk-to-clk delay for reliable write access after read on same address—Applicable to Opening Edge	0.50	0.59	ns
t_{RSTBQ}	RESET Low to Data Out Low on RD (flow-through)	1.10	1.29	ns
	RESET Low to Data Out Low on RD (pipelined)	1.10	1.29	ns
$t_{REMRSTB}$	RESET Removal	0.34	0.40	ns
$t_{RECRSTB}$	RESET Recovery	1.79	2.10	ns
$t_{MPWRSTB}$	RESET Minimum Pulse Width	0.25	0.30	ns
t_{CYC}	Clock Cycle Time	3.85	4.53	ns
F_{MAX}	Maximum Frequency	255	217	MHz

Notes:

1. For more information, refer to the application note [Simultaneous Read-Write Operations in Dual-Port SRAM for Flash-Based cSoCs and FPGAs](#).
2. For specific junction temperature and voltage supply levels, refer to [Table 2-5 on page 2-5](#) for derating values.

Table 2-119 • RAM4K9
Automotive-Case Conditions: $T_J = 115^\circ\text{C}$, Worst Case $V_{CC} = 1.425\text{ V}$

Parameter	Description	-1	Std.	Units
t_{AS}	Address Setup Time	0.30	0.35	ns
t_{AH}	Address Hold Time	0.00	0.00	ns
t_{ENS}	REN, WEN Setup Time	0.17	0.20	ns
t_{ENH}	REN, WEN Hold Time	0.12	0.14	ns
t_{BKS}	BLK Setup Time	0.28	0.33	ns
t_{BKH}	BLK Hold Time	0.02	0.03	ns
t_{DS}	Input data (DIN) Setup Time	0.22	0.26	ns
t_{DH}	Input data (DIN) Hold Time	0.00	0.00	ns
t_{CKQ1}	Clock High to New Data Valid on DOUT (output retained, WMODE = 0)	2.13	2.50	ns
	Clock High to New Data Valid on DOUT (flow-through, WMODE = 1)	2.81	3.30	ns
t_{CKQ2}	Clock High to New Data Valid on DOUT (pipelined)	1.07	1.25	ns
t_{C2CWWL}^1	Address collision clk-to-clk delay for reliable write after write on same address—Applicable to Closing Edge	0.28	0.33	ns
t_{C2CWWH}^1	Address collision clk-to-clk delay for reliable write after write on same address—Applicable to Rising Edge	0.26	0.30	ns
t_{C2CRWH}^1	Address collision clk-to-clk delay for reliable read access after write on same address—Applicable to Opening Edge	0.38	0.45	ns
t_{C2CWRH}^1	Address collision clk-to-clk delay for reliable write access after read on same address—Applicable to Opening Edge	0.42	0.49	ns
t_{RSTBQ}	RESET Low to Data Out Low on DOUT (flow-through)	1.10	1.29	ns
	RESET Low to Data Out Low on DOUT (pipelined)	1.10	1.29	ns
$t_{REMRSTB}$	RESET Removal	0.34	0.40	ns
$t_{RECRSTB}$	RESET Recovery	1.79	2.10	ns
$t_{MPWRSTB}$	RESET Minimum Pulse Width	0.25	0.30	ns
t_{CYC}	Clock Cycle Time	3.85	4.53	ns
F_{MAX}	Maximum Frequency	260	221	MHz

Notes:

1. For more information, refer to the application note [Simultaneous Read-Write Operations in Dual-Port SRAM for Flash-Based cSoCs and FPGAs](#).
2. For specific junction temperature and voltage supply levels, refer to [Table 2-5 on page 2-5](#) for derating values.

Table 2-120 • RAM512X18
Automotive-Case Conditions: $T_J = 115^\circ\text{C}$, Worst-Case $V_{CC} = 1.425\text{ V}$

Parameter	Description	-1	Std.	Units
t_{AS}	Address Setup Time	0.30	0.35	ns
t_{AH}	Address Hold Time	0.00	0.00	ns
t_{ENS}	REN, WEN Setup Time	0.11	0.13	ns
t_{ENH}	REN, WEN Hold Time	0.07	0.08	ns
t_{DS}	Input data (WD) Setup Time	0.22	0.26	ns
t_{DH}	Input data (WD) Hold Time	0.00	0.00	ns
t_{CKQ1}	Clock High to New Data Valid on RD (output retained, WMODE = 0)	2.58	3.03	ns
t_{CKQ2}	Clock High to New Data Valid on RD (pipelined)	1.07	1.26	ns
t_{C2CRWH}^1	Address collision clk-to-clk delay for reliable read access after write on same address—Applicable to Opening Edge	0.43	0.50	ns
t_{C2CWRH}^1	Address collision clk-to-clk delay for reliable write access after read on same address—Applicable to Opening Edge	0.50	0.59	ns
t_{RSTBQ}	RESET Low to Data Out Low on RD (flow-through)	1.10	1.29	ns
	RESET Low to Data Out Low on RD (pipelined)	1.10	1.29	ns
$t_{REMRSTB}$	RESET Removal	0.34	0.40	ns
$t_{RECRSTB}$	RESET Recovery	1.79	2.10	ns
$t_{MPWRSTB}$	RESET Minimum Pulse Width	0.25	0.30	ns
t_{CYC}	Clock Cycle Time	3.85	4.53	ns
F_{MAX}	Maximum Frequency	260	221	MHz

Notes:

1. For more information, refer to the application note [Simultaneous Read-Write Operations in Dual-Port SRAM for Flash-Based cSoCs and FPGAs](#).
2. For specific junction temperature and voltage supply levels, refer to [Table 2-5 on page 2-5](#) for derating values.

FIFO

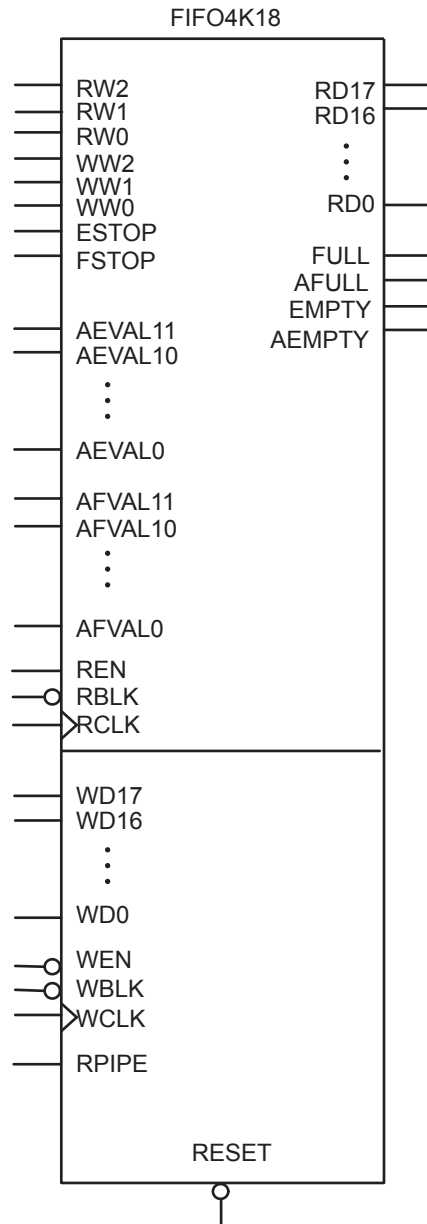

Figure 2-36 • FIFO Model

Timing Waveforms

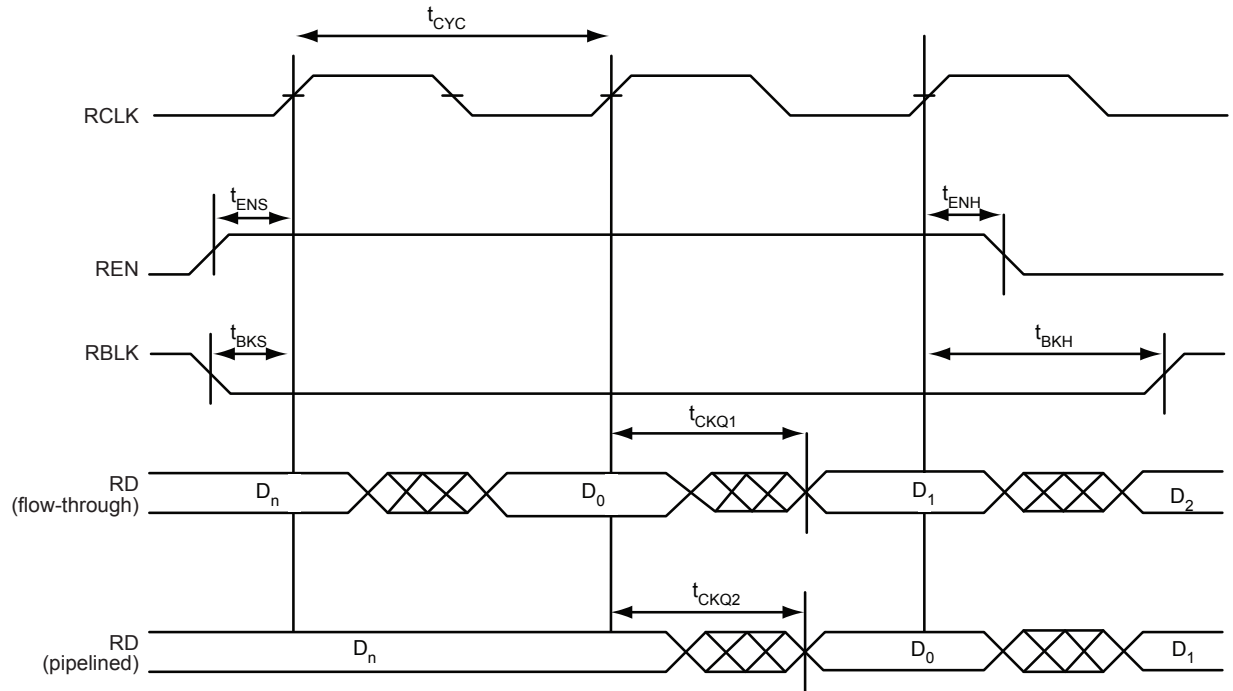

Figure 2-37 • FIFO Read

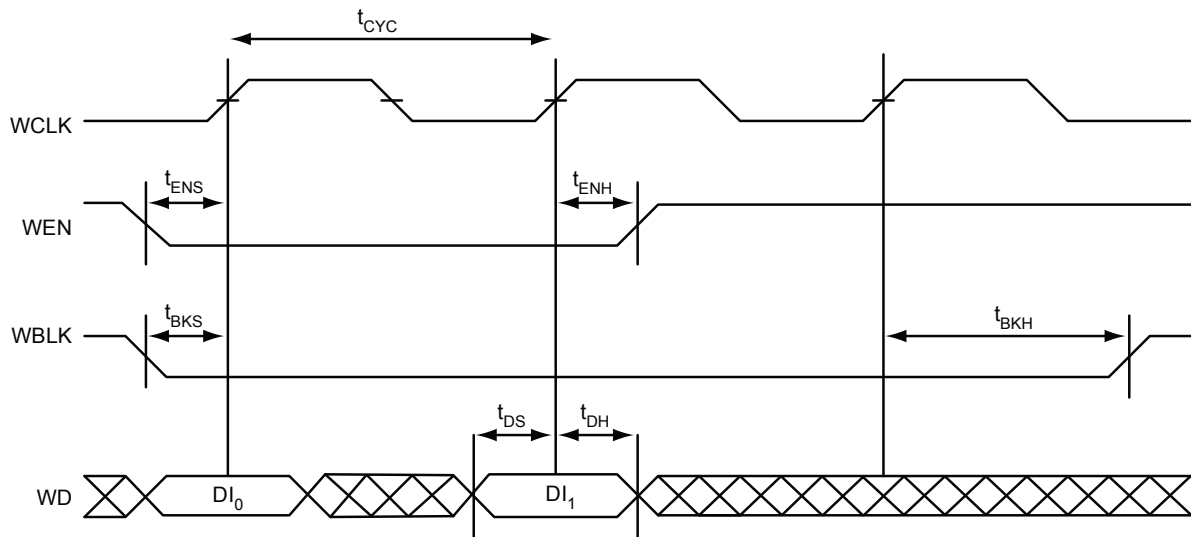
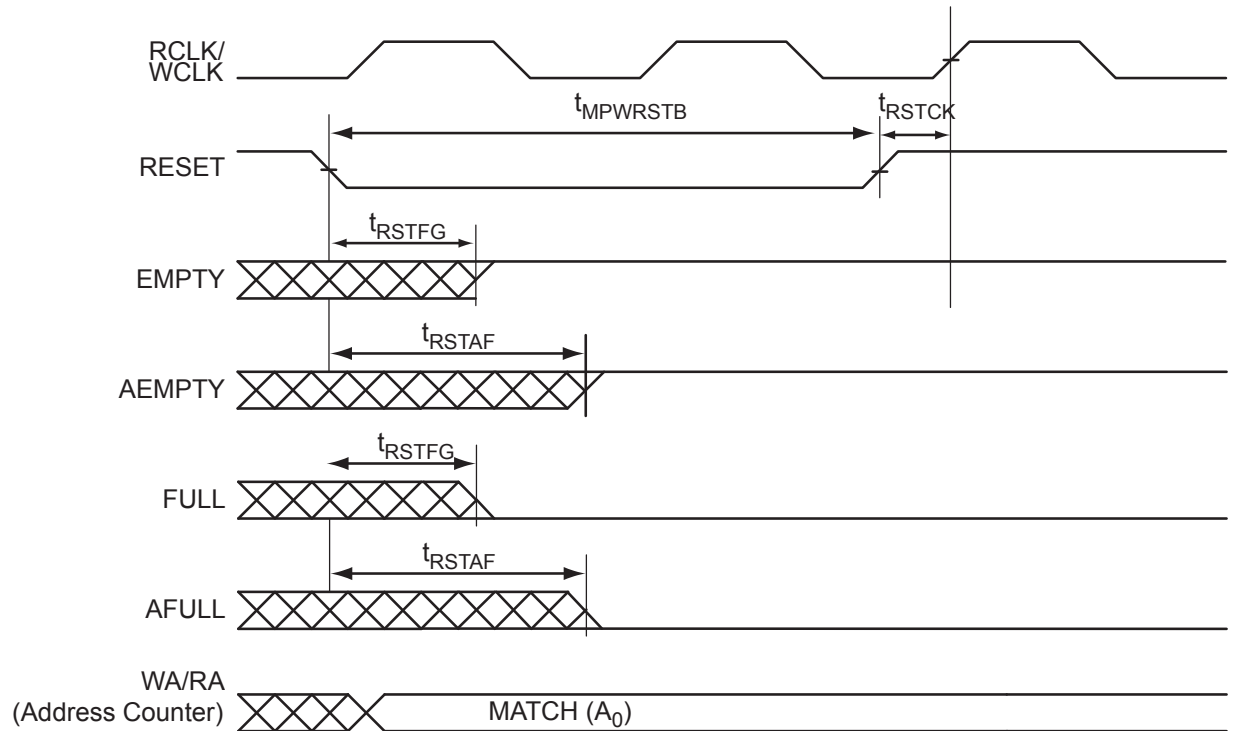
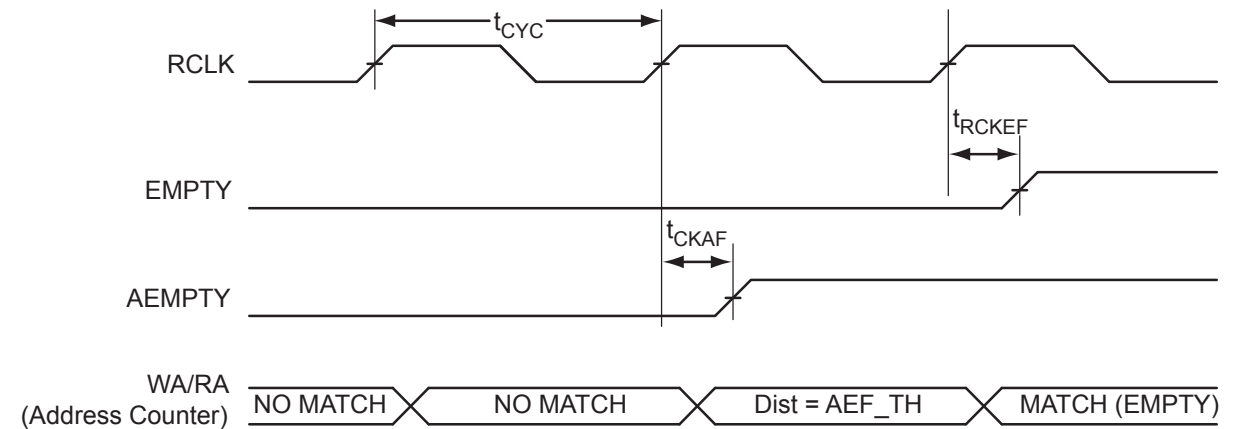
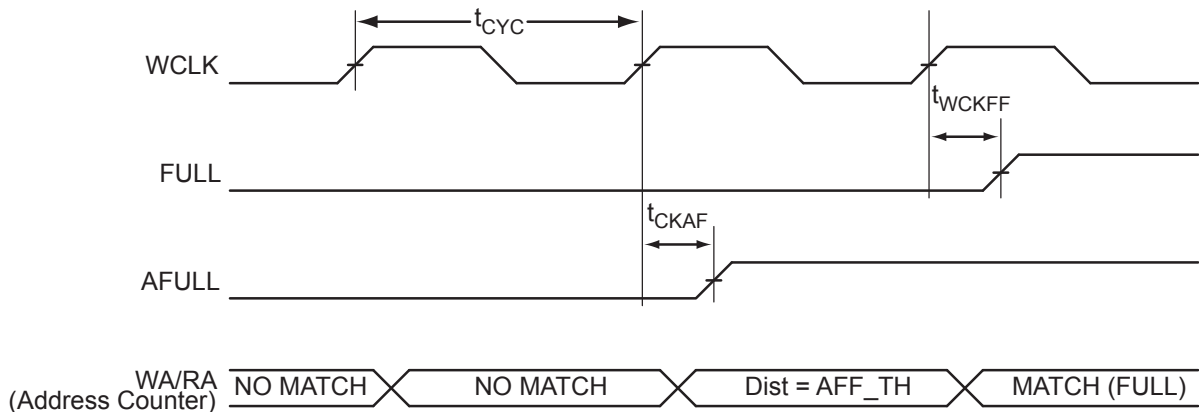
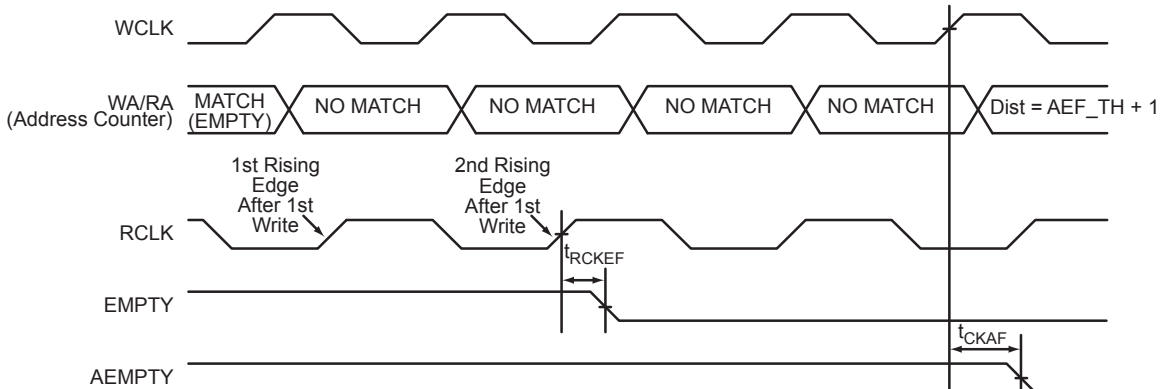
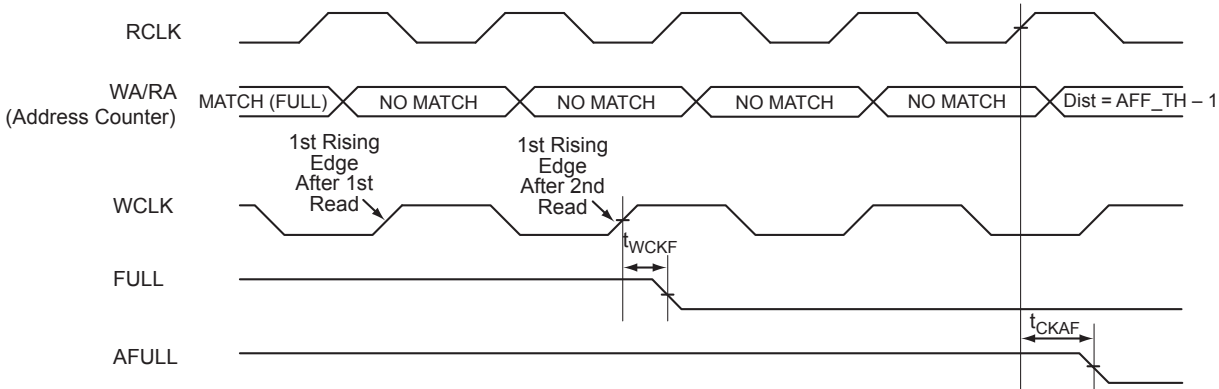

Figure 2-38 • FIFO Write

Figure 2-39 • FIFO Reset

Figure 2-40 • FIFO EMPTY Flag and AEMPTY Flag Assertion

Figure 2-41 • FIFO FULL Flag and AFULL Flag Assertion

Figure 2-42 • FIFO EMPTY Flag and AEMPTY Flag Deassertion

Figure 2-43 • FIFO FULL Flag and AFULL Flag Deassertion

Timing Characteristics

Table 2-121 • FIFO
Worst-Case Automotive Conditions: $T_J = 135^{\circ}\text{C}$, $V_{CC} = 1.425\text{ V}$

Parameter	Description	-1	Std.	Units
t_{ENS}	REN, WEN Setup Time	1.97	1.67	ns
t_{ENH}	REN, WEN Hold Time	0.03	0.02	ns
t_{BKS}	BLK Setup Time	0.28	0.32	ns
t_{BKH}	BLK Hold Time	0.00	0.00	ns
t_{DS}	Input Data (WD) Setup Time	0.26	0.22	ns
t_{DH}	Input Data (WD) Hold Time	0.00	0.00	ns
t_{CKQ1}	Clock High to New Data Valid on RD (flow-through)	3.37	2.86	ns
t_{CKQ2}	Clock High to New Data Valid on RD (pipelined)	1.28	1.09	ns
t_{RCKEF}	RCLK High to Empty Flag Valid	2.45	2.09	ns
t_{WCKFF}	WCLK High to Full Flag Valid	2.33	1.98	ns
t_{CKAF}	Clock High to Almost Empty/Full Flag Valid	8.85	7.53	ns
t_{RSTFG}	RESET Low to Empty/Full Flag Valid	2.42	2.06	ns
t_{RSTAF}	RESET Low to Almost Empty/Full Flag Valid	8.76	7.45	ns
t_{RSTBQ}	RESET Low to Data Out Low on RD (flow-through)	1.32	1.12	ns
	RESET Low to Data Out Low on RD (pipelined)	1.32	1.12	ns
$t_{REMRSTB}$	RESET Removal	0.41	0.35	ns
$t_{RECRSTB}$	RESET Recovery	2.14	1.82	ns
$t_{MPWRSTB}$	RESET Minimum Pulse Width	0.30	0.26	ns
t_{CYC}	Clock Cycle Time	4.62	3.93	ns
F_{MAX}	Maximum Frequency for FIFO	217	255	MHz

Note: For specific junction temperature and voltage supply levels, refer to [Table 2-5 on page 2-5](#) for derating values.

Table 2-122 • FIFO
Worst-Case Automotive Conditions: $T_J = 115^\circ\text{C}$, $V_{CC} = 1.425\text{ V}$

Parameter	Description	-1	Std.	Units
t_{ENS}	REN, WEN Setup Time	1.93	1.64	ns
t_{ENH}	REN, WEN Hold Time	0.03	0.02	ns
t_{BKS}	BLK Setup Time	0.27	0.32	ns
t_{BKH}	BLK Hold Time	0.00	0.00	ns
t_{DS}	Input Data (WD) Setup Time	0.26	0.22	ns
t_{DH}	Input Data (WD) Hold Time	0.00	0.00	ns
t_{CKQ1}	Clock High to New Data Valid on RD (flow-through)	3.30	2.81	ns
t_{CKQ2}	Clock High to New Data Valid on RD (pipelined)	1.25	1.07	ns
t_{RCKEF}	RCLK High to Empty Flag Valid	2.41	2.05	ns
t_{WCKFF}	WCLK High to Full Flag Valid	2.29	1.95	ns
t_{CKAF}	Clock High to Almost Empty/Full Flag Valid	8.68	7.38	ns
t_{RSTFG}	RESET Low to Empty/Full Flag Valid	2.37	2.02	ns
t_{RSTAF}	RESET Low to Almost Empty/Full Flag Valid	8.59	7.30	ns
t_{RSTBQ}	RESET Low to Data Out Low on RD (flow-through)	1.29	1.10	ns
	RESET Low to Data Out Low on RD (pipelined)	1.29	1.10	ns
$t_{REMRSTB}$	RESET Removal	0.40	0.34	ns
$t_{RECRSTB}$	RESET Recovery	2.10	1.79	ns
$t_{MPWRSTB}$	RESET Minimum Pulse Width	0.30	0.25	ns
t_{CYC}	Clock Cycle Time	4.53	3.85	ns
F_{MAX}	Maximum Frequency for FIFO	221	260	MHz

Note: For specific junction temperature and voltage supply levels, refer to [Table 2-5 on page 2-5](#) for derating values.

Embedded FlashROM Characteristics

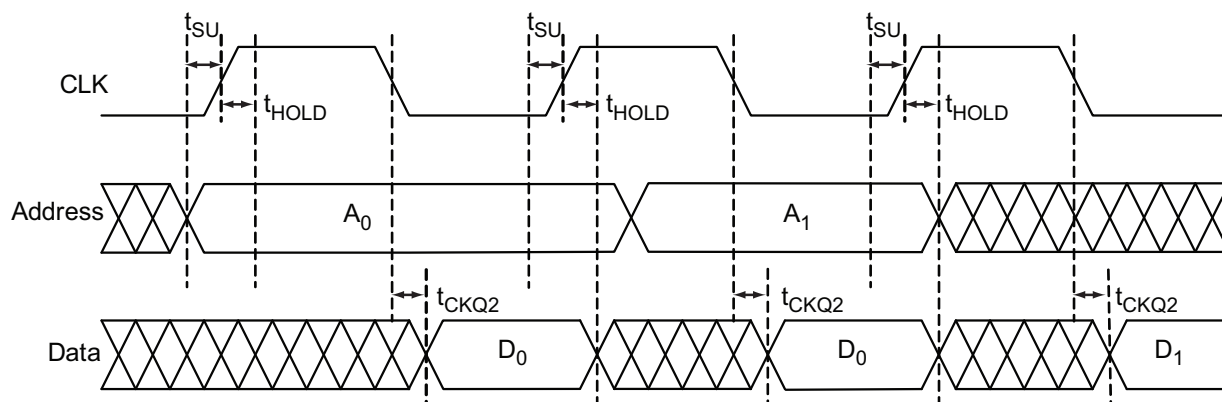

Figure 2-44 • Timing Diagram

Timing Characteristics

Table 2-123 • Embedded FlashROM Access Time

Automotive-Case Conditions: $T_j = 135^\circ\text{C}$, Worst-Case VCC = 1.425 V

Parameter	Description	-1	Std.	Units
t_{SU}	Address Setup Time	0.65	0.76	ns
t_{HOLD}	Address Hold Time	0.00	0.00	ns
t_{CK2Q}	Clock to Out	19.73	23.20	ns
F_{MAX}	Maximum Clock Frequency	15	15	MHz

Table 2-124 • Embedded FlashROM Access Time

Automotive-Case Conditions: $T_j = 115^\circ\text{C}$, Worst-Case VCC = 1.425 V

Parameter	Description	-1	Std.	Units
t_{SU}	Address Setup Time	0.64	0.75	ns
t_{HOLD}	Address Hold Time	0.00	0.00	ns
t_{CK2Q}	Clock to Out	19.35	22.74	ns
F_{MAX}	Maximum Clock Frequency	15	15	MHz

JTAG 1532 Characteristics

JTAG timing delays do not include JTAG I/Os. To obtain complete JTAG timing, add I/O buffer delays to the corresponding standard selected; refer to the I/O timing characteristics in the "User I/O Characteristics" section on page 2-12 for more details.

Timing Characteristics

Table 2-125 • JTAG 1532

Commercial-Case Conditions: $T_j = 70^\circ\text{C}$, Worst-Case $V_{CC} = 1.425\text{ V}$

Parameter	Description	-2	-1	Std.	Units
t_{DISU}	Test Data Input Setup Time				ns
t_{DIHD}	Test Data Input Hold Time				ns
t_{TMSSU}	Test Mode Select Setup Time				ns
t_{TMDHD}	Test Mode Select Hold Time				ns
t_{TCK2Q}	Clock to Q (data out)				ns
t_{RSTB2Q}	Reset to Q (data out)				ns
F_{TCKMAX}	TCK Maximum Frequency	20	20	20	MHz
$t_{TRSTREM}$	ResetB Removal Time				ns
$t_{TRSTREC}$	ResetB Recovery Time				ns
$t_{TRSTMPW}$	ResetB Minimum Pulse				ns

Note: For specific junction temperature and voltage supply levels, refer to Table 2-5 on page 2-5 for derating values.

3 – Pin Descriptions and Packaging

Supply Pins

GND**Ground**

Ground supply voltage to the core, I/O outputs, and I/O logic.

GNDQ**Ground (quiet)**

Quiet ground supply voltage to input buffers of I/O banks. Within the package, the GNDQ plane is decoupled from the simultaneous switching noise originated from the output buffer ground domain. This minimizes the noise transfer within the package and improves input signal integrity. GNDQ must always be connected to GND on the board.

VCC**Core Supply Voltage**

Supply voltage to the FPGA core, nominally 1.5 V. VCC is required for powering the JTAG state machine in addition to VJTAG. Even when a device is in bypass mode in a JTAG chain of interconnected devices, both VCC and VJTAG must remain powered to allow JTAG signals to pass through the device.

VCCIBx**I/O Supply Voltage**

Supply voltage to the bank's I/O output buffers and I/O logic. Bx is the I/O bank number. There are up to four I/O banks on Automotive ProASIC3 devices, plus a dedicated VJTAG bank. Each bank can have a separate VCCI connection. All I/Os in a bank will run off the same VCCIBx supply. VCCI can be 1.5 V, 1.8 V, 2.5 V, or 3.3 V, nominal voltage. Unused I/O banks should have their corresponding VCCI pins tied to GND.

VMVx**I/O Supply Voltage (quiet)**

Quiet supply voltage to the input buffers of each I/O bank. x is the bank number. Within the package, the VMV plane biases the input stage of the I/Os in the I/O banks. This minimizes the noise transfer within the package and improves input signal integrity. Each bank must have at least one VMV connection, and no VMV should be left unconnected. All I/Os in a bank run off the same VMVx supply. VMV is used to provide a quiet supply voltage to the input buffers of each I/O bank. VMVx can be 1.5 V, 1.8 V, 2.5 V, or 3.3 V, nominal voltage. Unused I/O banks should have their corresponding VMV pins tied to GND. VMV and VCCI should be at the same voltage within a given I/O bank. Used VMV pins must be connected to the corresponding VCCI pins of the same bank (i.e., VMV0 to VCCIB0, VMV1 to VCCIB1, etc.).

VCCPLA/B/C/D/E/F**PLL Supply Voltage**

Supply voltage to analog PLL, nominally 1.5 V.

When the PLLs are not used, the Designer place-and-route tool automatically disables the unused PLLs to lower power consumption. The user should tie unused VCCPLx and VCOMPLx pins to ground. Microsemi recommends tying VCCPLx to VCC and using proper filtering circuits to decouple VCC noise from the PLLs. Refer to the PLL Power Supply Decoupling section of the "Clock Conditioning Circuits in IGLOO and ProASIC3 Devices" chapter of the *Automotive ProASIC3 FPGA Fabric User's Guide* for a complete board solution for the PLL analog power supply and ground.

There is one VCCPLF pin on Automotive ProASIC3 devices.

VCOMPLA/B/C/D/E/F**PLL Ground**

Ground to analog PLL power supplies. When the PLLs are not used, the Designer place-and-route tool automatically disables the unused PLLs to lower power consumption. The user should tie unused VCCPLx and VCOMPLx pins to ground.

There is one VCOMPLF pin on Automotive ProASIC3 devices.

VJTAG**JTAG Supply Voltage**

Automotive ProASIC3 devices have a separate bank for the dedicated JTAG pins. The JTAG pins can be run at any voltage from 1.5 V to 3.3 V (nominal). Isolating the JTAG power supply in a separate I/O bank gives greater flexibility in supply selection and simplifies power supply and PCB design. If the JTAG interface is neither used nor planned for use, the VJTAG pin together with the TRST pin could be tied to GND. It should be noted that VCC is required to be powered for JTAG operation; VJTAG alone is

insufficient. If a device is in a JTAG chain of interconnected boards, the board containing the device can be powered down, provided both VJTAG and VCC to the part remain powered; otherwise, JTAG signals will not be able to transition the device, even in bypass mode.

Microsemi recommends that VPUMP and VJTAG power supplies be kept separate with independent filtering capacitors rather than supplying them from a common rail.

VPUMP Programming Supply Voltage

Automotive ProASIC3 devices support single-voltage ISP of the configuration flash and FlashROM. For programming, VPUMP should be 3.3 V nominal. During normal device operation, VPUMP can be left floating or can be tied (pulled up) to any voltage between 0 V and the VPUMP maximum. Programming power supply voltage (VPUMP) range is listed in the datasheet.

When the VPUMP pin is tied to ground, it will shut off the charge pump circuitry, resulting in no sources of oscillation from the charge pump circuitry.

For proper programming, 0.01 μF and 0.33 μF capacitors (both rated at 16 V) are to be connected in parallel across VPUMP and GND, and positioned as close to the FPGA pins as possible.

Microsemi recommends that VPUMP and VJTAG power supplies be kept separate with independent filtering capacitors rather than supplying them from a common rail.

User Pins

I/O User Input/Output

The I/O pin functions as an input, output, tristate, or bidirectional buffer. Input and output signal levels are compatible with the I/O standard selected.

During programming, I/Os become tristated and weakly pulled up to VCCI. With VCCI, VMV, and VCC supplies continuously powered up, when the device transitions from programming to operating mode, the I/Os are instantly configured to the desired user configuration.

Unused I/Os are configured as follows:

- Output buffer is disabled (with tristate value of high impedance)
- Input buffer is disabled (with tristate value of high impedance)
- Weak pull-up is programmed

GL Globals

GL I/Os have access to certain clock conditioning circuitry (and the PLL) and/or have direct access to the global network (spines). Additionally, the global I/Os can be used as regular I/Os, since they have identical capabilities. Unused GL pins are configured as inputs with pull-up resistors.

See more detailed descriptions of global I/O connectivity in the "Clock Conditioning Circuits in IGLOO and ProASIC3 Devices" chapter of the *Automotive ProASIC3 FPGA Fabric User's Guide*. All inputs labeled GC/GF are direct inputs into the quadrant clocks. For example, if GAA0 is used for an input, GAA1 and GAA2 are no longer available for input to the quadrant globals. All inputs labeled GC/GF are direct inputs into the chip-level globals, and the rest are connected to the quadrant globals. The inputs to the global network are multiplexed, and only one input can be used as a global input.

Refer to the "I/O Structures in IGLOO and ProASIC3 Devices" chapter of the *Automotive ProASIC3 FPGA Fabric User's Guide* for an explanation of the naming of global pins.

JTAG Pins

Automotive ProASIC3 devices have a separate bank for the dedicated JTAG pins. The JTAG pins can be run at any voltage from 1.5 V to 3.3 V (nominal). VCC must also be powered for the JTAG state machine to operate, even if the device is in bypass mode; VJTAG alone is insufficient. Both VJTAG and VCC to the part must be supplied to allow JTAG signals to transition the device. Isolating the JTAG power supply in a separate I/O bank gives greater flexibility in supply selection and simplifies power supply and PCB design. If the JTAG interface is neither used nor planned for use, the VJTAG pin together with the TRST pin could be tied to GND.

TCK **Test Clock**

Test clock input for JTAG boundary scan, ISP, and UJTAG. The TCK pin does not have an internal pull-up/down resistor. If JTAG is not used, Actel recommends tying off TCK to GND through a resistor placed close to the FPGA pin. This prevents JTAG operation in case TMS enters an undesired state.

Note that to operate at all VJTAG voltages, 500 Ω to 1 k Ω will satisfy the requirements. Refer to [Table 3-1](#) for more information.

Table 3-1 • Recommended Tie-Off Values for the TCK and TRST Pins

VJTAG	Tie-Off Resistance
VJTAG at 3.3 V	200 Ω to 1 k Ω
VJTAG at 2.5 V	200 Ω to 1 k Ω
VJTAG at 1.8 V	500 Ω to 1 k Ω
VJTAG at 1.5 V	500 Ω to 1 k Ω

Notes:

1. Equivalent parallel resistance if more than one device is on the JTAG chain
2. The TCK pin can be pulled up/down.
3. The TRST pin is pulled down.

TDI **Test Data Input**

Serial input for JTAG boundary scan, ISP, and UJTAG usage. There is an internal weak pull-up resistor on the TDI pin.

TDO **Test Data Output**

Serial output for JTAG boundary scan, ISP, and UJTAG usage.

TMS **Test Mode Select**

The TMS pin controls the use of the IEEE 1532 boundary scan pins (TCK, TDI, TDO, TRST). There is an internal weak pull-up resistor on the TMS pin.

TRST **Boundary Scan Reset Pin**

The TRST pin functions as an active-low input to asynchronously initialize (or reset) the boundary scan circuitry. There is an internal weak pull-up resistor on the TRST pin. If JTAG is not used, an external pull-down resistor could be included to ensure the test access port (TAP) is held in reset mode. The resistor values must be chosen from [Table 3-1](#) and must satisfy the parallel resistance value requirement. The values in [Table 3-1](#) correspond to the resistor recommended when a single device is used, and the equivalent parallel resistor when multiple devices are connected via a JTAG chain.

In critical applications, an upset in the JTAG circuit could allow entrance to an undesired JTAG state. In such cases, Actel recommends tying off TRST to GND through a resistor placed close to the FPGA pin.

Note that to operate at all VJTAG voltages, 500 Ω to 1 k Ω will satisfy the requirements.

Special Function Pins

NC

This pin is not connected to circuitry within the device. These pins can be driven to any voltage or can be left floating with no effect on the operation of the device.

No Connect**DC**

This pin should not be connected to any signals on the PCB. These pins should be left unconnected.

Do Not Connect

Packaging

Semiconductor technology is constantly shrinking in size while growing in capability and functional integration. To enable next-generation silicon technologies, semiconductor packages have also evolved to provide improved performance and flexibility.

Microsemi consistently delivers packages that provide the necessary mechanical and environmental protection to ensure consistent reliability and performance. Microsemi IC packaging technology efficiently supports high-density FPGAs with large-pin-count Ball Grid Arrays (BGAs), but is also flexible enough to accommodate stringent form factor requirements for Chip Scale Packaging (CSP). In addition, Actel offers a variety of packages designed to meet your most demanding application and economic requirements for today's embedded and mobile systems.

Related Documents

User's Guides

Automotive ProASIC FPGA Fabric User's Guide

http://www.microsemi.com/soc/documents/PA3_Auto_UG.pdf

Packaging

The following documents provide packaging information and device selection for low power flash devices.

Product Catalog

http://www.microsemi.com/soc/documents/ProdCat_PIB.pdf

Lists devices currently recommended for new designs and the packages available for each member of the family. Use this document or the datasheet tables to determine the best package for your design, and which package drawing to use.

Package Mechanical Drawings

<http://www.microsemi.com/soc/documents/PckgMechDrwngs.pdf>

This document contains the package mechanical drawings for all packages currently or previously supplied by Actel. Use the bookmarks to navigate to the package mechanical drawings.

Additional packaging materials: <http://www.microsemi.com/soc/products/solutions/package/docs.aspx>.

4 – Package Pin Assignments

VQ100

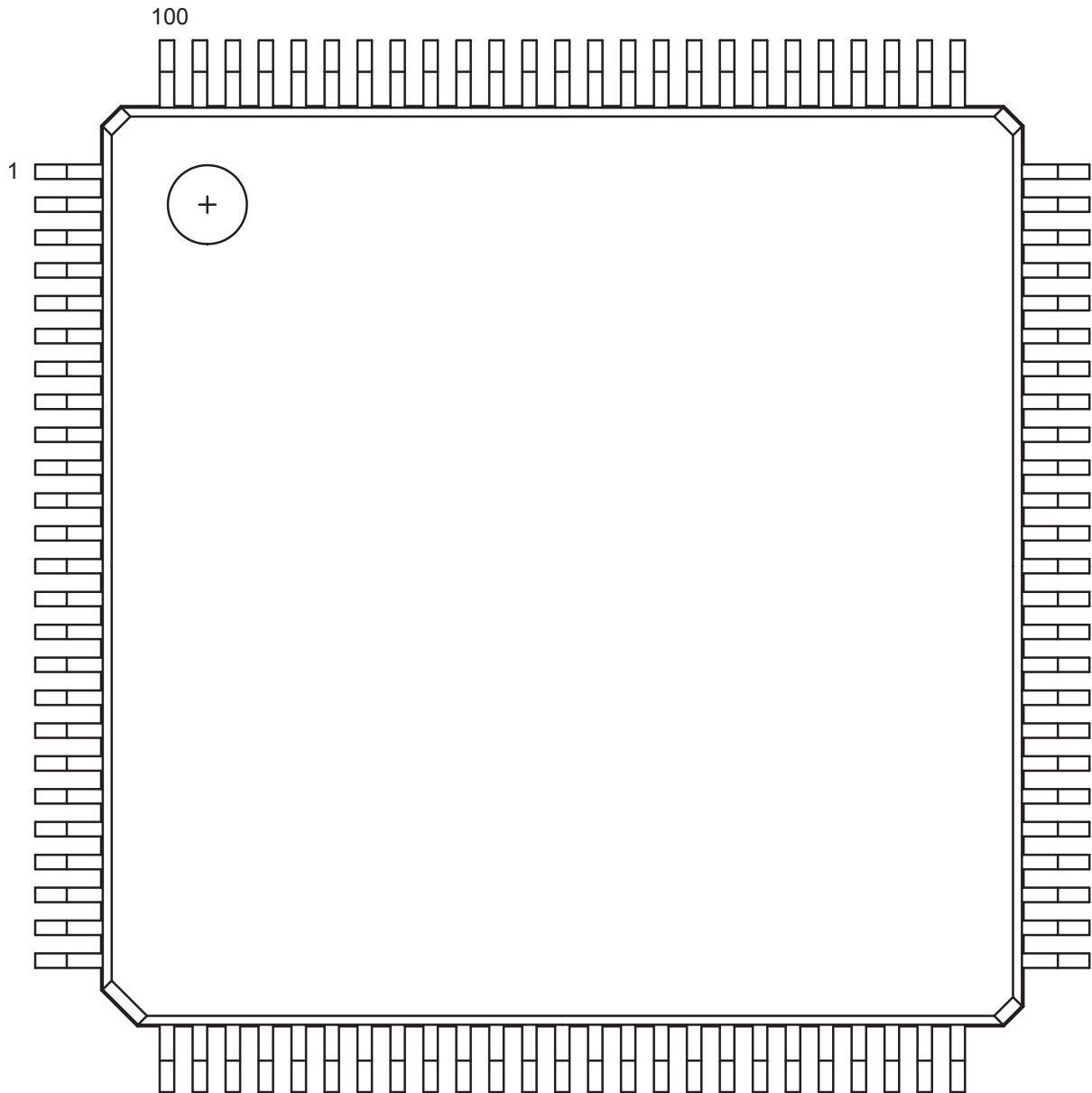

Note: This is the top view of the package.

Note

For Package Manufacturing and Environmental information, visit the Resource Center at <http://www.actel.com/products/solutions/package/docs.aspx>.

VQ100	
Pin Number	A3P060 Function
1	GND
2	GAA2/IO51RSB1
3	IO52RSB1
4	GAB2/IO53RSB1
5	IO95RSB1
6	GAC2/IO94RSB1
7	IO93RSB1
8	IO92RSB1
9	GND
10	GFB1/IO87RSB1
11	GFB0/IO86RSB1
12	VCOMPLF
13	GFA0/IO85RSB1
14	VCCPLF
15	GFA1/IO84RSB1
16	GFA2/IO83RSB1
17	VCC
18	VCCIB1
19	GEC1/IO77RSB1
20	GEB1/IO75RSB1
21	GEB0/IO74RSB1
22	GEA1/IO73RSB1
23	GEA0/IO72RSB1
24	VMV1
25	GNDQ
26	GEA2/IO71RSB1
27	GEB2/IO70RSB1
28	GEC2/IO69RSB1
29	IO68RSB1
30	IO67RSB1
31	IO66RSB1
32	IO65RSB1
33	IO64RSB1
34	IO63RSB1

VQ100	
Pin Number	A3P060 Function
35	IO62RSB1
36	IO61RSB1
37	VCC
38	GND
39	VCCIB1
40	IO60RSB1
41	IO59RSB1
42	IO58RSB1
43	IO57RSB1
44	GDC2/IO56RSB1
45	GDB2/IO55RSB1
46	GDA2/IO54RSB1
47	TCK
48	TDI
49	TMS
50	VMV1
51	GND
52	VPUMP
53	NC
54	TDO
55	TRST
56	VJTAG
57	GDA1/IO49RSB0
58	GDC0/IO46RSB0
59	GDC1/IO45RSB0
60	GCC2/IO43RSB0
61	GCB2/IO42RSB0
62	GCA0/IO40RSB0
63	GCA1/IO39RSB0
64	GCC0/IO36RSB0
65	GCC1/IO35RSB0
66	VCCIB0
67	GND
68	VCC

VQ100	
Pin Number	A3P060 Function
69	IO31RSB0
70	GBC2/IO29RSB0
71	GBB2/IO27RSB0
72	IO26RSB0
73	GBA2/IO25RSB0
74	VMV0
75	GNDQ
76	GBA1/IO24RSB0
77	GBA0/IO23RSB0
78	GBB1/IO22RSB0
79	GBB0/IO21RSB0
80	GBC1/IO20RSB0
81	GBC0/IO19RSB0
82	IO18RSB0
83	IO17RSB0
84	IO15RSB0
85	IO13RSB0
86	IO11RSB0
87	VCCIB0
88	GND
89	VCC
90	IO10RSB0
91	IO09RSB0
92	IO08RSB0
93	GAC1/IO07RSB0
94	GAC0/IO06RSB0
95	GAB1/IO05RSB0
96	GAB0/IO04RSB0
97	GAA1/IO03RSB0
98	GAA0/IO02RSB0
99	IO01RSB0
100	IO00RSB0

VQ100	
Pin Number	A3P125 Function
1	GND
2	GAA2/IO67RSB1
3	IO68RSB1
4	GAB2/IO69RSB1
5	IO132RSB1
6	GAC2/IO131RSB1
7	IO130RSB1
8	IO129RSB1
9	GND
10	GFB1/IO124RSB1
11	GFB0/IO123RSB1
12	VCOMPLF
13	GFA0/IO122RSB1
14	VCCPLF
15	GFA1/IO121RSB1
16	GFA2/IO120RSB1
17	VCC
18	VCCIB1
19	GEC0/IO111RSB1
20	GEB1/IO110RSB1
21	GEB0/IO109RSB1
22	GEA1/IO108RSB1
23	GEA0/IO107RSB1
24	VMV1
25	GNDQ
26	GEA2/IO106RSB1
27	GEB2/IO105RSB1
28	GEC2/IO104RSB1
29	IO102RSB1
30	IO100RSB1
31	IO99RSB1
32	IO97RSB1
33	IO96RSB1
34	IO95RSB1
35	IO94RSB1
36	IO93RSB1

VQ100	
Pin Number	A3P125 Function
37	VCC
38	GND
39	VCCIB1
40	IO87RSB1
41	IO84RSB1
42	IO81RSB1
43	IO75RSB1
44	GDC2/IO72RSB1
45	GDB2/IO71RSB1
46	GDA2/IO70RSB1
47	TCK
48	TDI
49	TMS
50	VMV1
51	GND
52	VPUMP
53	NC
54	TDO
55	TRST
56	VJTAG
57	GDA1/IO65RSB0
58	GDC0/IO62RSB0
59	GDC1/IO61RSB0
60	GCC2/IO59RSB0
61	GCB2/IO58RSB0
62	GCA0/IO56RSB0
63	GCA1/IO55RSB0
64	GCC0/IO52RSB0
65	GCC1/IO51RSB0
66	VCCIB0
67	GND
68	VCC
69	IO47RSB0
70	GBC2/IO45RSB0
71	GBB2/IO43RSB0
72	IO42RSB0

VQ100	
Pin Number	A3P125 Function
73	GBA2/IO41RSB0
74	VMV0
75	GNDQ
76	GBA1/IO40RSB0
77	GBA0/IO39RSB0
78	GBB1/IO38RSB0
79	GBB0/IO37RSB0
80	GBC1/IO36RSB0
81	GBC0/IO35RSB0
82	IO32RSB0
83	IO28RSB0
84	IO25RSB0
85	IO22RSB0
86	IO19RSB0
87	VCCIB0
88	GND
89	VCC
90	IO15RSB0
91	IO13RSB0
92	IO11RSB0
93	IO09RSB0
94	IO07RSB0
95	GAC1/IO05RSB0
96	GAC0/IO04RSB0
97	GAB1/IO03RSB0
98	GAB0/IO02RSB0
99	GAA1/IO01RSB0
100	GAA0/IO00RSB0

VQ100		VQ100		VQ100	
Pin Number	A3P250 Function	Pin Number	A3P250 Function	Pin Number	A3P250 Function
1	GND	35	IO85RSB2	69	IO43NDB1
2	GAA2/IO118UDB3	36	IO84RSB2	70	GBC2/IO43PDB1
3	IO118VDB3	37	VCC	71	GBB2/IO42PSB1
4	GAB2/IO117UDB3	38	GND	72	IO41NDB1
5	IO117VDB3	39	VCCIB2	73	GBA2/IO41PDB1
6	GAC2/IO116UDB3	40	IO77RSB2	74	VMV1
7	IO116VDB3	41	IO74RSB2	75	GNDQ
8	IO112PSB3	42	IO71RSB2	76	GBA1/IO40RSB0
9	GND	43	GDC2/IO63RSB2	77	GBA0/IO39RSB0
10	GFB1/IO109PDB3	44	GDB2/IO62RSB2	78	GBB1/IO38RSB0
11	GFB0/IO109NDB3	45	GDA2/IO61RSB2	79	GBB0/IO37RSB0
12	VCOMPLF	46	GNDQ	80	GBC1/IO36RSB0
13	GFA0/IO108NPB3	47	TCK	81	GBC0/IO35RSB0
14	VCCPLF	48	TDI	82	IO29RSB0
15	GFA1/IO108PPB3	49	TMS	83	IO27RSB0
16	GFA2/IO107PSB3	50	VMV2	84	IO25RSB0
17	VCC	51	GND	85	IO23RSB0
18	VCCIB3	52	VPUMP	86	IO21RSB0
19	GFC2/IO105PSB3	53	NC	87	VCCIB0
20	GEC1/IO100PDB3	54	TDO	88	GND
21	GEC0/IO100NDB3	55	TRST	89	VCC
22	GEA1/IO98PDB3	56	VJTAG	90	IO15RSB0
23	GEA0/IO98NDB3	57	GDA1/IO60USB1	91	IO13RSB0
24	VMV3	58	GDC0/IO58VDB1	92	IO11RSB0
25	GNDQ	59	GDC1/IO58UDB1	93	GAC1/IO05RSB0
26	GEA2/IO97RSB2	60	IO52NDB1	94	GAC0/IO04RSB0
27	GEB2/IO96RSB2	61	GCB2/IO52PDB1	95	GAB1/IO03RSB0
28	GEC2/IO95RSB2	62	GCA1/IO50PDB1	96	GAB0/IO02RSB0
29	IO93RSB2	63	GCA0/IO50NDB1	97	GAA1/IO01RSB0
30	IO92RSB2	64	GCC0/IO48NDB1	98	GAA0/IO00RSB0
31	IO91RSB2	65	GCC1/IO48PDB1	99	GNDQ
32	IO90RSB2	66	VCCIB1	100	VMV0
33	IO88RSB2	67	GND		
34	IO86RSB2	68	VCC		

QN132

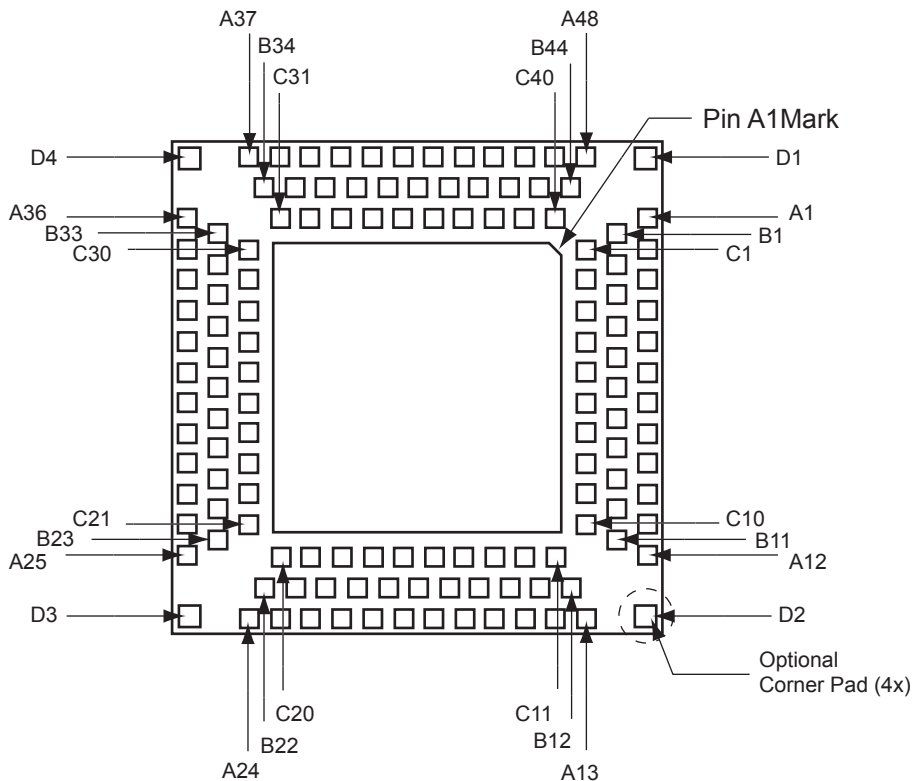

Notes:

1. This is the bottom view of the package.
2. The die attach paddle center of the package is tied to ground (GND).

Note

For Package Manufacturing and Environmental information, visit the Resource Center at <http://www.actel.com/products/solutions/package/docs.aspx>.

QN132	
Pin Number	A3P125 Function
A1	GAB2/IO69RSB1
A2	IO130RSB1
A3	VCCIB1
A4	GFC1/IO126RSB1
A5	GFB0/IO123RSB1
A6	VCCPLF
A7	GFA1/IO121RSB1
A8	GFC2/IO118RSB1
A9	IO115RSB1
A10	VCC
A11	GEB1/IO110RSB1
A12	GEA0/IO107RSB1
A13	GEC2/IO104RSB1
A14	IO100RSB1
A15	VCC
A16	IO99RSB1
A17	IO96RSB1
A18	IO94RSB1
A19	IO91RSB1
A20	IO85RSB1
A21	IO79RSB1
A22	VCC
A23	GDB2/IO71RSB1
A24	TDI
A25	TRST
A26	GDC1/IO61RSB0
A27	VCC
A28	IO60RSB0
A29	GCC2/IO59RSB0
A30	GCA2/IO57RSB0
A31	GCA0/IO56RSB0
A32	GCB1/IO53RSB0
A33	IO49RSB0
A34	VCC
A35	IO44RSB0
A36	GBA2/IO41RSB0

QN132	
Pin Number	A3P125 Function
A37	GBB1/IO38RSB0
A38	GBC0/IO35RSB0
A39	VCCIB0
A40	IO28RSB0
A41	IO22RSB0
A42	IO18RSB0
A43	IO14RSB0
A44	IO11RSB0
A45	IO07RSB0
A46	VCC
A47	GAC1/IO05RSB0
A48	GAB0/IO02RSB0
B1	IO68RSB1
B2	GAC2/IO131RSB1
B3	GND
B4	GFC0/IO125RSB1
B5	VCOMPLF
B6	GND
B7	GFB2/IO119RSB1
B8	IO116RSB1
B9	GND
B10	GEB0/IO109RSB1
B11	VMV1
B12	GEB2/IO105RSB1
B13	IO101RSB1
B14	GND
B15	IO98RSB1
B16	IO95RSB1
B17	GND
B18	IO87RSB1
B19	IO81RSB1
B20	GND
B21	GNDQ
B22	TMS
B23	TDO
B24	GDC0/IO62RSB0

QN132	
Pin Number	A3P125 Function
B25	GND
B26	NC
B27	GCB2/IO58RSB0
B28	GND
B29	GCB0/IO54RSB0
B30	GCC1/IO51RSB0
B31	GND
B32	GBB2/IO43RSB0
B33	VMV0
B34	GBA0/IO39RSB0
B35	GBC1/IO36RSB0
B36	GND
B37	IO26RSB0
B38	IO21RSB0
B39	GND
B40	IO13RSB0
B41	IO08RSB0
B42	GND
B43	GAC0/IO04RSB0
B44	GNDQ
C1	GAA2/IO67RSB1
C2	IO132RSB1
C3	VCC
C4	GFB1/IO124RSB1
C5	GFA0/IO122RSB1
C6	GFA2/IO120RSB1
C7	IO117RSB1
C8	VCCIB1
C9	GEA1/IO108RSB1
C10	GNDQ
C11	GEA2/IO106RSB1
C12	IO103RSB1
C13	VCCIB1
C14	IO97RSB1
C15	IO93RSB1
C16	IO89RSB1

QN132	
Pin Number	A3P125 Function
C17	IO83RSB1
C18	VCCIB1
C19	TCK
C20	VMV1
C21	VPUMP
C22	VJTAG
C23	VCCIB0
C24	NC
C25	NC
C26	GCA1/IO55RSB0
C27	GCC0/IO52RSB0
C28	VCCIB0
C29	IO42RSB0
C30	GNDQ
C31	GBA1/IO40RSB0
C32	GBB0/IO37RSB0
C33	VCC
C34	IO24RSB0
C35	IO19RSB0
C36	IO16RSB0
C37	IO10RSB0
C38	VCCIB0
C39	GAB1/IO03RSB0
C40	VMV0
D1	GND
D2	GND
D3	GND
D4	GND

QN132	
Pin Number	A3P250 Function
A1	GAB2/IO117UPB3
A2	IO117VPB3
A3	VCCIB3
A4	GFC1/IO110PDB3
A5	GFB0/IO109NPB3
A6	VCCPLF
A7	GFA1/IO108PPB3
A8	GFC2/IO105PPB3
A9	IO103NDB3
A10	VCC
A11	GEA1/IO98PPB3
A12	GEA0/IO98NPB3
A13	GEC2/IO95RSB2
A14	IO91RSB2
A15	VCC
A16	IO90RSB2
A17	IO87RSB2
A18	IO85RSB2
A19	IO82RSB2
A20	IO76RSB2
A21	IO70RSB2
A22	VCC
A23	GDB2/IO62RSB2
A24	TDI
A25	TRST
A26	GDC1/IO58UDB1
A27	VCC
A28	IO54NDB1
A29	IO52NDB1
A30	GCA2/IO51PPB1
A31	GCA0/IO50NPB1
A32	GCB1/IO49PDB1
A33	IO47NSB1
A34	VCC
A35	IO41NPB1
A36	GBA2/IO41PPB1

QN132	
Pin Number	A3P250 Function
A37	GBB1/IO38RSB0
A38	GBC0/IO35RSB0
A39	VCCIB0
A40	IO28RSB0
A41	IO22RSB0
A42	IO18RSB0
A43	IO14RSB0
A44	IO11RSB0
A45	IO07RSB0
A46	VCC
A47	GAC1/IO05RSB0
A48	GAB0/IO02RSB0
B1	IO118VDB3
B2	GAC2/IO116UDB3
B3	GND
B4	GFC0/IO110NDB3
B5	VCOMPLF
B6	GND
B7	GFB2/IO106PSB3
B8	IO103PDB3
B9	GND
B10	GEB0/IO99NDB3
B11	VMV3
B12	GEB2/IO96RSB2
B13	IO92RSB2
B14	GND
B15	IO89RSB2
B16	IO86RSB2
B17	GND
B18	IO78RSB2
B19	IO72RSB2
B20	GND
B21	GNDQ
B22	TMS
B23	TDO
B24	GDC0/IO58VDB1

QN132	
Pin Number	A3P250 Function
B25	GND
B26	IO54PDB1
B27	GCB2/IO52PDB1
B28	GND
B29	GCB0/IO49NDB1
B30	GCC1/IO48PDB1
B31	GND
B32	GBB2/IO42PDB1
B33	VMV1
B34	GBA0/IO39RSB0
B35	GBC1/IO36RSB0
B36	GND
B37	IO26RSB0
B38	IO21RSB0
B39	GND
B40	IO13RSB0
B41	IO08RSB0
B42	GND
B43	GAC0/IO04RSB0
B44	GNDQ
C1	GAA2/IO118UDB3
C2	IO116VDB3
C3	VCC
C4	GFB1/IO109PPB3
C5	GFA0/IO108NPB3
C6	GFA2/IO107PSB3
C7	IO105NPB3
C8	VCCIB3
C9	GEB1/IO99PDB3
C10	GNDQ
C11	GAA2/IO97RSB2
C12	IO94RSB2
C13	VCCIB2
C14	IO88RSB2
C15	IO84RSB2
C16	IO80RSB2

QN132	
Pin Number	A3P250 Function
C17	IO74RSB2
C18	VCCIB2
C19	TCK
C20	VMV2
C21	VPUMP
C22	VJTAG
C23	VCCIB1
C24	IO53NSB1
C25	IO51NPB1
C26	GCA1/IO50PPB1
C27	GCC0/IO48NDB1
C28	VCCIB1
C29	IO42NDB1
C30	GNDQ
C31	GBA1/IO40RSB0
C32	GBB0/IO37RSB0
C33	VCC
C34	IO24RSB0
C35	IO19RSB0
C36	IO16RSB0
C37	IO10RSB0
C38	VCCIB0
C39	GAB1/IO03RSB0
C40	VMV0
D1	GND
D2	GND
D3	GND
D4	GND

FG144

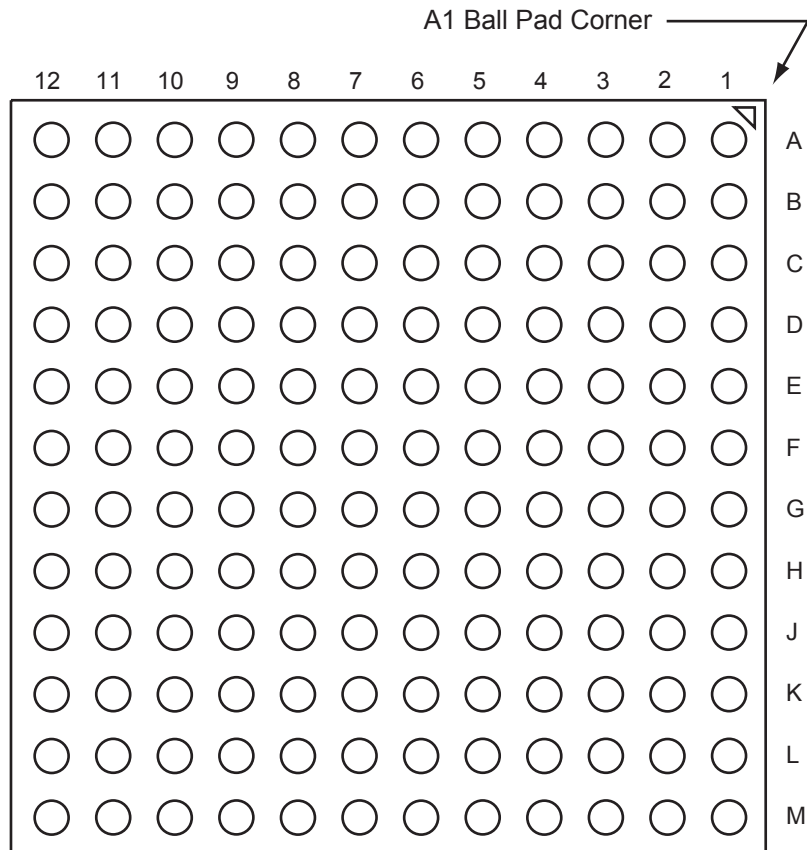

Note: This is the bottom view of the package.

Note

For Package Manufacturing and Environmental information, visit the Resource Center at <http://www.actel.com/products/solutions/package/docs.aspx>.

FG144		FG144		FG144	
Pin Number	A3P060 Function	Pin Number	A3P060 Function	Pin Number	A3P060 Function
A1	GNDQ	D1	IO91RSB1	G1	GFA1/IO84RSB1
A2	VMV0	D2	IO92RSB1	G2	GND
A3	GAB0/IO04RSB0	D3	IO93RSB1	G3	VCCPLF
A4	GAB1/IO05RSB0	D4	GAA2/IO51RSB1	G4	GFA0/IO85RSB1
A5	IO08RSB0	D5	GAC0/IO06RSB0	G5	GND
A6	GND	D6	GAC1/IO07RSB0	G6	GND
A7	IO11RSB0	D7	GBC0/IO19RSB0	G7	GND
A8	VCC	D8	GBC1/IO20RSB0	G8	GDC1/IO45RSB0
A9	IO16RSB0	D9	GBB2/IO27RSB0	G9	IO32RSB0
A10	GBA0/IO23RSB0	D10	IO18RSB0	G10	GCC2/IO43RSB0
A11	GBA1/IO24RSB0	D11	IO28RSB0	G11	IO31RSB0
A12	GNDQ	D12	GCB1/IO37RSB0	G12	GCB2/IO42RSB0
B1	GAB2/IO53RSB1	E1	VCC	H1	VCC
B2	GND	E2	GFC0/IO88RSB1	H2	GFB2/IO82RSB1
B3	GAA0/IO02RSB0	E3	GFC1/IO89RSB1	H3	GFC2/IO81RSB1
B4	GAA1/IO03RSB0	E4	VCCIB1	H4	GEC1/IO77RSB1
B5	IO00RSB0	E5	IO52RSB1	H5	VCC
B6	IO10RSB0	E6	VCCIB0	H6	IO34RSB0
B7	IO12RSB0	E7	VCCIB0	H7	IO44RSB0
B8	IO14RSB0	E8	GCC1/IO35RSB0	H8	GDB2/IO55RSB1
B9	GBB0/IO21RSB0	E9	VCCIB0	H9	GDC0/IO46RSB0
B10	GBB1/IO22RSB0	E10	VCC	H10	VCCIB0
B11	GND	E11	GCA0/IO40RSB0	H11	IO33RSB0
B12	VMV0	E12	IO30RSB0	H12	VCC
C1	IO95RSB1	F1	GFB0/IO86RSB1	J1	GEB1/IO75RSB1
C2	GFA2/IO83RSB1	F2	VCOMPLF	J2	IO78RSB1
C3	GAC2/IO94RSB1	F3	GFB1/IO87RSB1	J3	VCCIB1
C4	VCC	F4	IO90RSB1	J4	GEC0/IO76RSB1
C5	IO01RSB0	F5	GND	J5	IO79RSB1
C6	IO09RSB0	F6	GND	J6	IO80RSB1
C7	IO13RSB0	F7	GND	J7	VCC
C8	IO15RSB0	F8	GCC0/IO36RSB0	J8	TCK
C9	IO17RSB0	F9	GCB0/IO38RSB0	J9	GDA2/IO54RSB1
C10	GBA2/IO25RSB0	F10	GND	J10	TDO
C11	IO26RSB0	F11	GCA1/IO39RSB0	J11	GDA1/IO49RSB0
C12	GBC2/IO29RSB0	F12	GCA2/IO41RSB0	J12	GDB1/IO47RSB0

FG144	
Pin Number	A3P060 Function
K1	GEB0/IO74RSB1
K2	GEA1/IO73RSB1
K3	GEA0/IO72RSB1
K4	GEA2/IO71RSB1
K5	IO65RSB1
K6	IO64RSB1
K7	GND
K8	IO57RSB1
K9	GDC2/IO56RSB1
K10	GND
K11	GDA0/IO50RSB0
K12	GDB0/IO48RSB0
L1	GND
L2	VMV1
L3	GEB2/IO70RSB1
L4	IO67RSB1
L5	VCCIB1
L6	IO62RSB1
L7	IO59RSB1
L8	IO58RSB1
L9	TMS
L10	VJTAG
L11	VMV1
L12	TRST
M1	GNDQ
M2	GEC2/IO69RSB1
M3	IO68RSB1
M4	IO66RSB1
M5	IO63RSB1
M6	IO61RSB1
M7	IO60RSB1
M8	NC
M9	TDI
M10	VCCIB1
M11	VPUMP
M12	GNDQ

FG144	
Pin Number	A3P125 Function
A1	GNDQ
A2	VMV0
A3	GAB0/IO02RSB0
A4	GAB1/IO03RSB0
A5	IO11RSB0
A6	GND
A7	IO18RSB0
A8	VCC
A9	IO25RSB0
A10	GBA0/IO39RSB0
A11	GBA1/IO40RSB0
A12	GNDQ
B1	GAB2/IO69RSB1
B2	GND
B3	GAA0/IO00RSB0
B4	GAA1/IO01RSB0
B5	IO08RSB0
B6	IO14RSB0
B7	IO19RSB0
B8	IO22RSB0
B9	GBB0/IO37RSB0
B10	GBB1/IO38RSB0
B11	GND
B12	VMV0
C1	IO132RSB1
C2	GFA2/IO120RSB1
C3	GAC2/IO131RSB1
C4	VCC
C5	IO10RSB0
C6	IO12RSB0
C7	IO21RSB0
C8	IO24RSB0
C9	IO27RSB0
C10	GBA2/IO41RSB0
C11	IO42RSB0
C12	GBC2/IO45RSB0

FG144	
Pin Number	A3P125 Function
D1	IO128RSB1
D2	IO129RSB1
D3	IO130RSB1
D4	GAA2/IO67RSB1
D5	GAC0/IO04RSB0
D6	GAC1/IO05RSB0
D7	GBC0/IO35RSB0
D8	GBC1/IO36RSB0
D9	GBB2/IO43RSB0
D10	IO28RSB0
D11	IO44RSB0
D12	GCB1/IO53RSB0
E1	VCC
E2	GFC0/IO125RSB1
E3	GFC1/IO126RSB1
E4	VCCIB1
E5	IO68RSB1
E6	VCCIB0
E7	VCCIB0
E8	GCC1/IO51RSB0
E9	VCCIB0
E10	VCC
E11	GCA0/IO56RSB0
E12	IO46RSB0
F1	GFB0/IO123RSB1
F2	VCOMPLF
F3	GFB1/IO124RSB1
F4	IO127RSB1
F5	GND
F6	GND
F7	GND
F8	GCC0/IO52RSB0
F9	GCB0/IO54RSB0
F10	GND
F11	GCA1/IO55RSB0
F12	GCA2/IO57RSB0

FG144	
Pin Number	A3P125 Function
G1	GFA1/IO121RSB1
G2	GND
G3	VCCPLF
G4	GFA0/IO122RSB1
G5	GND
G6	GND
G7	GND
G8	GDC1/IO61RSB0
G9	IO48RSB0
G10	GCC2/IO59RSB0
G11	IO47RSB0
G12	GCB2/IO58RSB0
H1	VCC
H2	GFB2/IO119RSB1
H3	GFC2/IO118RSB1
H4	GEC1/IO112RSB1
H5	VCC
H6	IO50RSB0
H7	IO60RSB0
H8	GDB2/IO71RSB1
H9	GDC0/IO62RSB0
H10	VCCIB0
H11	IO49RSB0
H12	VCC
J1	GEB1/IO110RSB1
J2	IO115RSB1
J3	VCCIB1
J4	GEC0/IO111RSB1
J5	IO116RSB1
J6	IO117RSB1
J7	VCC
J8	TCK
J9	GDA2/IO70RSB1
J10	TDO
J11	GDA1/IO65RSB0
J12	GDB1/IO63RSB0

FG144	
Pin Number	A3P125 Function
K1	GEB0/IO109RSB1
K2	GEA1/IO108RSB1
K3	GEA0/IO107RSB1
K4	GEA2/IO106RSB1
K5	IO100RSB1
K6	IO98RSB1
K7	GND
K8	IO73RSB1
K9	GDC2/IO72RSB1
K10	GND
K11	GDA0/IO66RSB0
K12	GDB0/IO64RSB0
L1	GND
L2	VMV1
L3	GEB2/IO105RSB1
L4	IO102RSB1
L5	VCCIB1
L6	IO95RSB1
L7	IO85RSB1
L8	IO74RSB1
L9	TMS
L10	VJTAG
L11	VMV1
L12	TRST
M1	GNDQ
M2	GEC2/IO104RSB1
M3	IO103RSB1
M4	IO101RSB1
M5	IO97RSB1
M6	IO94RSB1
M7	IO86RSB1
M8	IO75RSB1
M9	TDI
M10	VCCIB1
M11	VPUMP
M12	GNDQ

FG144		FG144		FG144	
Pin Number	A3P250 Function	Pin Number	A3P250 Function	Pin Number	A3P250 Function
A1	GNDQ	D1	IO112NDB3	G1	GFA1/IO108PPB3
A2	VMV0	D2	IO112PDB3	G2	GND
A3	GAB0/IO02RSB0	D3	IO116VDB3	G3	VCCPLF
A4	GAB1/IO03RSB0	D4	GAA2/IO118UPB3	G4	GFA0/IO108NPB3
A5	IO16RSB0	D5	GAC0/IO04RSB0	G5	GND
A6	GND	D6	GAC1/IO05RSB0	G6	GND
A7	IO29RSB0	D7	GBC0/IO35RSB0	G7	GND
A8	VCC	D8	GBC1/IO36RSB0	G8	GDC1/IO58UPB1
A9	IO33RSB0	D9	GBB2/IO42PDB1	G9	IO53NDB1
A10	GBA0/IO39RSB0	D10	IO42NDB1	G10	GCC2/IO53PDB1
A11	GBA1/IO40RSB0	D11	IO43NPB1	G11	IO52NDB1
A12	GNDQ	D12	GCB1/IO49PPB1	G12	GCB2/IO52PDB1
B1	GAB2/IO117UDB3	E1	VCC	H1	VCC
B2	GND	E2	GFC0/IO110NDB3	H2	GFB2/IO106PDB3
B3	GAA0/IO00RSB0	E3	GFC1/IO110PDB3	H3	GFC2/IO105PSB3
B4	GAA1/IO01RSB0	E4	VCCIB3	H4	GEC1/IO100PDB3
B5	IO14RSB0	E5	IO118VPB3	H5	VCC
B6	IO19RSB0	E6	VCCIB0	H6	IO79RSB2
B7	IO22RSB0	E7	VCCIB0	H7	IO65RSB2
B8	IO30RSB0	E8	GCC1/IO48PDB1	H8	GDB2/IO62RSB2
B9	GBB0/IO37RSB0	E9	VCCIB1	H9	GDC0/IO58VPB1
B10	GBB1/IO38RSB0	E10	VCC	H10	VCCIB1
B11	GND	E11	GCA0/IO50NDB1	H11	IO54PSB1
B12	VMV1	E12	IO51NDB1	H12	VCC
C1	IO117VDB3	F1	GFB0/IO109NPB3	J1	GEB1/IO99PDB3
C2	GFA2/IO107PPB3	F2	VCOMPLF	J2	IO106NDB3
C3	GAC2/IO116UDB3	F3	GFB1/IO109PPB3	J3	VCCIB3
C4	VCC	F4	IO107NPB3	J4	GEC0/IO100NDB3
C5	IO12RSB0	F5	GND	J5	IO88RSB2
C6	IO17RSB0	F6	GND	J6	IO81RSB2
C7	IO24RSB0	F7	GND	J7	VCC
C8	IO31RSB0	F8	GCC0/IO48NDB1	J8	TCK
C9	IO34RSB0	F9	GCB0/IO49NPB1	J9	GDA2/IO61RSB2
C10	GBA2/IO41PDB1	F10	GND	J10	TDO
C11	IO41NDB1	F11	GCA1/IO50PDB1	J11	GDA1/IO60UDB1
C12	GBC2/IO43PPB1	F12	GCA2/IO51PDB1	J12	GDB1/IO59UDB1

FG144	
Pin Number	A3P250 Function
K1	GEB0/IO99NDB3
K2	GEA1/IO98PDB3
K3	GEA0/IO98NDB3
K4	GEA2/IO97RSB2
K5	IO90RSB2
K6	IO84RSB2
K7	GND
K8	IO66RSB2
K9	GDC2/IO63RSB2
K10	GND
K11	GDA0/IO60VDB1
K12	GDB0/IO59VDB1
L1	GND
L2	VMV3
L3	GEB2/IO96RSB2
L4	IO91RSB2
L5	VCCIB2
L6	IO82RSB2
L7	IO80RSB2
L8	IO72RSB2
L9	TMS
L10	VJTAG
L11	VMV2
L12	TRST
M1	GNDQ
M2	GEC2/IO95RSB2
M3	IO92RSB2
M4	IO89RSB2
M5	IO87RSB2
M6	IO85RSB2
M7	IO78RSB2
M8	IO76RSB2
M9	TDI
M10	VCCIB2
M11	VPUMP
M12	GNDQ

FG144	
Pin Number	A3P1000 Function
A1	GNDQ
A2	VMV0
A3	GAB0/IO02RSB0
A4	GAB1/IO03RSB0
A5	IO10RSB0
A6	GND
A7	IO44RSB0
A8	VCC
A9	IO69RSB0
A10	GBA0/IO76RSB0
A11	GBA1/IO77RSB0
A12	GNDQ
B1	GAB2/IO224PDB3
B2	GND
B3	GAA0/IO00RSB0
B4	GAA1/IO01RSB0
B5	IO13RSB0
B6	IO26RSB0
B7	IO35RSB0
B8	IO60RSB0
B9	GBB0/IO74RSB0
B10	GBB1/IO75RSB0
B11	GND
B12	VMV1
C1	IO224NDB3
C2	GFA2/IO206PPB3
C3	GAC2/IO223PDB3
C4	VCC
C5	IO16RSB0
C6	IO29RSB0
C7	IO32RSB0
C8	IO63RSB0
C9	IO66RSB0
C10	GBA2/IO78PDB1
C11	IO78NDB1
C12	GBC2/IO80PPB1

FG144	
Pin Number	A3P1000 Function
D1	IO213PDB3
D2	IO213NDB3
D3	IO223NDB3
D4	GAA2/IO225PPB3
D5	GAC0/IO04RSB0
D6	GAC1/IO05RSB0
D7	GBC0/IO72RSB0
D8	GBC1/IO73RSB0
D9	GBB2/IO79PDB1
D10	IO79NDB1
D11	IO80NPB1
D12	GCB1/IO92PPB1
E1	VCC
E2	GFC0/IO209NDB3
E3	GFC1/IO209PDB3
E4	VCCIB3
E5	IO225NPB3
E6	VCCIB0
E7	VCCIB0
E8	GCC1/IO91PDB1
E9	VCCIB1
E10	VCC
E11	GCA0/IO93NDB1
E12	IO94NDB1
F1	GFB0/IO208NPB3
F2	VCOMPLF
F3	GFB1/IO208PPB3
F4	IO206NPB3
F5	GND
F6	GND
F7	GND
F8	GCC0/IO91NDB1
F9	GCB0/IO92NPB1
F10	GND
F11	GCA1/IO93PDB1
F12	GCA2/IO94PDB1

FG144	
Pin Number	A3P1000 Function
G1	GFA1/IO207PPB3
G2	GND
G3	VCCPLF
G4	GFA0/IO207NPB3
G5	GND
G6	GND
G7	GND
G8	GDC1/IO111PPB1
G9	IO96NDB1
G10	GCC2/IO96PDB1
G11	IO95NDB1
G12	GCB2/IO95PDB1
H1	VCC
H2	GFB2/IO205PDB3
H3	GFC2/IO204PSB3
H4	GEC1/IO190PDB3
H5	VCC
H6	IO105PDB1
H7	IO105NDB1
H8	GDB2/IO115RSB2
H9	GDC0/IO111NPB1
H10	VCCIB1
H11	IO101PSB1
H12	VCC
J1	GEB1/IO189PDB3
J2	IO205NDB3
J3	VCCIB3
J4	GEC0/IO190NDB3
J5	IO160RSB2
J6	IO157RSB2
J7	VCC
J8	TCK
J9	GDA2/IO114RSB2
J10	TDO
J11	GDA1/IO113PDB1
J12	GDB1/IO112PDB1

FG144	
Pin Number	A3P1000 Function
K1	GEB0/IO189NDB3
K2	GEA1/IO188PDB3
K3	GEA0/IO188NDB3
K4	GEA2/IO187RSB2
K5	IO169RSB2
K6	IO152RSB2
K7	GND
K8	IO117RSB2
K9	GDC2/IO116RSB2
K10	GND
K11	GDA0/IO113NDB1
K12	GDB0/IO112NDB1
L1	GND
L2	VMV3
L3	GEB2/IO186RSB2
L4	IO172RSB2
L5	VCCIB2
L6	IO153RSB2
L7	IO144RSB2
L8	IO140RSB2
L9	TMS
L10	VJTAG
L11	VMV2
L12	TRST
M1	GNDQ
M2	GEC2/IO185RSB2
M3	IO173RSB2
M4	IO168RSB2
M5	IO161RSB2
M6	IO156RSB2
M7	IO145RSB2
M8	IO141RSB2
M9	TDI
M10	VCCIB2
M11	VPUMP
M12	GNDQ

FG256

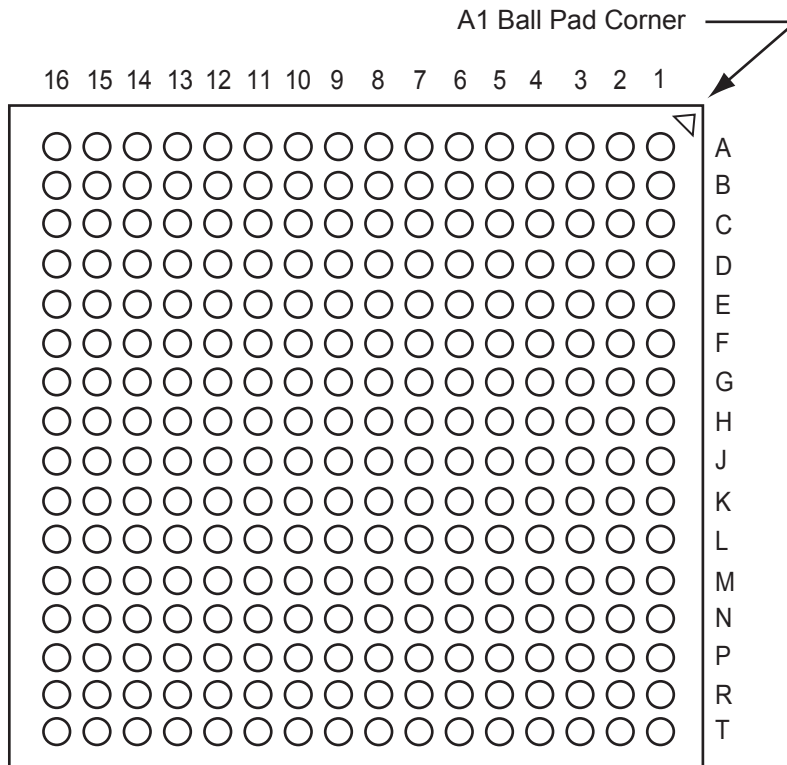

Note: This is the bottom view of the package.

Note

For Package Manufacturing and Environmental information, visit the Resource Center at <http://www.actel.com/products/solutions/package/docs.aspx>.

FG256	
Pin Number	A3P250 Function
A1	GND
A2	GAA0/IO00RSB0
A3	GAA1/IO01RSB0
A4	GAB0/IO02RSB0
A5	IO07RSB0
A6	IO10RSB0
A7	IO11RSB0
A8	IO15RSB0
A9	IO20RSB0
A10	IO25RSB0
A11	IO29RSB0
A12	IO33RSB0
A13	GBB1/IO38RSB0
A14	GBA0/IO39RSB0
A15	GBA1/IO40RSB0
A16	GND
B1	GAB2/IO117UDB3
B2	GAA2/IO118UDB3
B3	NC
B4	GAB1/IO03RSB0
B5	IO06RSB0
B6	IO09RSB0
B7	IO12RSB0
B8	IO16RSB0
B9	IO21RSB0
B10	IO26RSB0
B11	IO30RSB0
B12	GBC1/IO36RSB0
B13	GBB0/IO37RSB0
B14	NC
B15	GBA2/IO41PDB1
B16	IO41NDB1
C1	IO117VDB3
C2	IO118VDB3
C3	NC
C4	NC

FG256	
Pin Number	A3P250 Function
C5	GAC0/IO04RSB0
C6	GAC1/IO05RSB0
C7	IO13RSB0
C8	IO17RSB0
C9	IO22RSB0
C10	IO27RSB0
C11	IO31RSB0
C12	GBC0/IO35RSB0
C13	IO34RSB0
C14	NC
C15	IO42NPB1
C16	IO44PDB1
D1	IO114VDB3
D2	IO114UDB3
D3	GAC2/IO116UDB3
D4	NC
D5	GNDQ
D6	IO08RSB0
D7	IO14RSB0
D8	IO18RSB0
D9	IO23RSB0
D10	IO28RSB0
D11	IO32RSB0
D12	GNDQ
D13	NC
D14	GBB2/IO42PPB1
D15	NC
D16	IO44NDB1
E1	IO113PDB3
E2	NC
E3	IO116VDB3
E4	IO115UDB3
E5	VMV0
E6	VCCIB0
E7	VCCIB0
E8	IO19RSB0

FG256	
Pin Number	A3P250 Function
E9	IO24RSB0
E10	VCCIB0
E11	VCCIB0
E12	VMV1
E13	GBC2/IO43PDB1
E14	IO46RSB1
E15	NC
E16	IO45PDB1
F1	IO113NDB3
F2	IO112PPB3
F3	NC
F4	IO115VDB3
F5	VCCIB3
F6	GND
F7	VCC
F8	VCC
F9	VCC
F10	VCC
F11	GND
F12	VCCIB1
F13	IO43NDB1
F14	NC
F15	IO47PPB1
F16	IO45NDB1
G1	IO111NDB3
G2	IO111PDB3
G3	IO112NPB3
G4	GFC1/IO110PPB3
G5	VCCIB3
G6	VCC
G7	GND
G8	GND
G9	GND
G10	GND
G11	VCC
G12	VCCIB1

FG256	
Pin Number	A3P250 Function
G13	GCC1/IO48PPB1
G14	IO47NPB1
G15	IO54PDB1
G16	IO54NDB1
H1	GFB0/IO109NPB3
H2	GFA0/IO108NDB3
H3	GFB1/IO109PPB3
H4	VCOMPLF
H5	GFC0/IO110NPB3
H6	VCC
H7	GND
H8	GND
H9	GND
H10	GND
H11	VCC
H12	GCC0/IO48NPB1
H13	GCB1/IO49PPB1
H14	GCA0/IO50NPB1
H15	NC
H16	GCB0/IO49NPB1
J1	GFA2/IO107PPB3
J2	GFA1/IO108PDB3
J3	VCCPLF
J4	IO106NDB3
J5	GFB2/IO106PDB3
J6	VCC
J7	GND
J8	GND
J9	GND
J10	GND
J11	VCC
J12	GCB2/IO52PPB1
J13	GCA1/IO50PPB1
J14	GCC2/IO53PPB1
J15	NC
J16	GCA2/IO51PDB1

FG256	
Pin Number	A3P250 Function
K1	GFC2/IO105PDB3
K2	IO107NPB3
K3	IO104PPB3
K4	NC
K5	VCCIB3
K6	VCC
K7	GND
K8	GND
K9	GND
K10	GND
K11	VCC
K12	VCCIB1
K13	IO52NPB1
K14	IO55RSB1
K15	IO53NPB1
K16	IO51NDB1
L1	IO105NDB3
L2	IO104NPB3
L3	NC
L4	IO102RSB3
L5	VCCIB3
L6	GND
L7	VCC
L8	VCC
L9	VCC
L10	VCC
L11	GND
L12	VCCIB1
L13	GDB0/IO59VPB1
L14	IO57VDB1
L15	IO57UDB1
L16	IO56PDB1
M1	IO103PDB3
M2	NC
M3	IO101NPB3
M4	GEC0/IO100NPB3

FG256	
Pin Number	A3P250 Function
M5	VMV3
M6	VCCIB2
M7	VCCIB2
M8	NC
M9	IO74RSB2
M10	VCCIB2
M11	VCCIB2
M12	VMV2
M13	NC
M14	GDB1/IO59UPB1
M15	GDC1/IO58UDB1
M16	IO56NDB1
N1	IO103NDB3
N2	IO101PPB3
N3	GEC1/IO100PPB3
N4	NC
N5	GNDQ
N6	GEA2/IO97RSB2
N7	IO86RSB2
N8	IO82RSB2
N9	IO75RSB2
N10	IO69RSB2
N11	IO64RSB2
N12	GNDQ
N13	NC
N14	VJTAG
N15	GDC0/IO58VDB1
N16	GDA1/IO60UDB1
P1	GEB1/IO99PDB3
P2	GEB0/IO99NDB3
P3	NC
P4	NC
P5	IO92RSB2
P6	IO89RSB2
P7	IO85RSB2
P8	IO81RSB2

FG256	
Pin Number	A3P250 Function
P9	IO76RSB2
P10	IO71RSB2
P11	IO66RSB2
P12	NC
P13	TCK
P14	VPUMP
P15	TRST
P16	GDA0/IO60VDB1
R1	GEA1/IO98PDB3
R2	GEA0/IO98NDB3
R3	NC
R4	GEC2/IO95RSB2
R5	IO91RSB2
R6	IO88RSB2
R7	IO84RSB2
R8	IO80RSB2
R9	IO77RSB2
R10	IO72RSB2
R11	IO68RSB2
R12	IO65RSB2
R13	GDB2/IO62RSB2
R14	TDI
R15	NC
R16	TDO
T1	GND
T2	IO94RSB2
T3	GEB2/IO96RSB2
T4	IO93RSB2
T5	IO90RSB2
T6	IO87RSB2
T7	IO83RSB2
T8	IO79RSB2
T9	IO78RSB2
T10	IO73RSB2
T11	IO70RSB2
T12	GDC2/IO63RSB2

FG256	
Pin Number	A3P250 Function
T13	IO67RSB2
T14	GDA2/IO61RSB2
T15	TMS
T16	GND

FG256		FG256		FG256	
Pin Number	A3P1000 Function	Pin Number	A3P1000 Function	Pin Number	A3P1000 Function
A1	GND	C5	GAC0/IO04RSB0	E9	IO47RSB0
A2	GAA0/IO00RSB0	C6	GAC1/IO05RSB0	E10	VCCIB0
A3	GAA1/IO01RSB0	C7	IO25RSB0	E11	VCCIB0
A4	GAB0/IO02RSB0	C8	IO36RSB0	E12	VMV1
A5	IO16RSB0	C9	IO42RSB0	E13	GBC2/IO80PDB1
A6	IO22RSB0	C10	IO49RSB0	E14	IO83PPB1
A7	IO28RSB0	C11	IO56RSB0	E15	IO86PPB1
A8	IO35RSB0	C12	GBC0/IO72RSB0	E16	IO87PDB1
A9	IO45RSB0	C13	IO62RSB0	F1	IO217NDB3
A10	IO50RSB0	C14	VMV0	F2	IO218NDB3
A11	IO55RSB0	C15	IO78NDB1	F3	IO216PDB3
A12	IO61RSB0	C16	IO81NDB1	F4	IO216NDB3
A13	GBB1/IO75RSB0	D1	IO222NDB3	F5	VCCIB3
A14	GBA0/IO76RSB0	D2	IO222PDB3	F6	GND
A15	GBA1/IO77RSB0	D3	GAC2/IO223PDB3	F7	VCC
A16	GND	D4	IO223NDB3	F8	VCC
B1	GAB2/IO224PDB3	D5	GNDQ	F9	VCC
B2	GAA2/IO225PDB3	D6	IO23RSB0	F10	VCC
B3	GNDQ	D7	IO29RSB0	F11	GND
B4	GAB1/IO03RSB0	D8	IO33RSB0	F12	VCCIB1
B5	IO17RSB0	D9	IO46RSB0	F13	IO83NPB1
B6	IO21RSB0	D10	IO52RSB0	F14	IO86NPB1
B7	IO27RSB0	D11	IO60RSB0	F15	IO90PPB1
B8	IO34RSB0	D12	GNDQ	F16	IO87NDB1
B9	IO44RSB0	D13	IO80NDB1	G1	IO210PSB3
B10	IO51RSB0	D14	GBB2/IO79PDB1	G2	IO213NDB3
B11	IO57RSB0	D15	IO79NDB1	G3	IO213PDB3
B12	GBC1/IO73RSB0	D16	IO82NSB1	G4	GFC1/IO209PPB3
B13	GBB0/IO74RSB0	E1	IO217PDB3	G5	VCCIB3
B14	IO71RSB0	E2	IO218PDB3	G6	VCC
B15	GBA2/IO78PDB1	E3	IO221NDB3	G7	GND
B16	IO81PDB1	E4	IO221PDB3	G8	GND
C1	IO224NDB3	E5	VMV0	G9	GND
C2	IO225NDB3	E6	VCCIB0	G10	GND
C3	VMV3	E7	VCCIB0	G11	VCC
C4	IO11RSB0	E8	IO38RSB0	G12	VCCIB1

FG256	
Pin Number	A3P1000 Function
G13	GCC1/IO91PPB1
G14	IO90NPB1
G15	IO88PDB1
G16	IO88NDB1
H1	GFB0/IO208NPB3
H2	GFA0/IO207NDB3
H3	GFB1/IO208PPB3
H4	VCOMPLF
H5	GFC0/IO209NPB3
H6	VCC
H7	GND
H8	GND
H9	GND
H10	GND
H11	VCC
H12	GCC0/IO91NPB1
H13	GCB1/IO92PPB1
H14	GCA0/IO93NPB1
H15	IO96NPB1
H16	GCB0/IO92NPB1
J1	GFA2/IO206PSB3
J2	GFA1/IO207PDB3
J3	VCCPLF
J4	IO205NDB3
J5	GFB2/IO205PDB3
J6	VCC
J7	GND
J8	GND
J9	GND
J10	GND
J11	VCC
J12	GCB2/IO95PPB1
J13	GCA1/IO93PPB1
J14	GCC2/IO96PPB1
J15	IO100PPB1
J16	GCA2/IO94PSB1

FG256	
Pin Number	A3P1000 Function
K1	GFC2/IO204PDB3
K2	IO204NDB3
K3	IO203NDB3
K4	IO203PDB3
K5	VCCIB3
K6	VCC
K7	GND
K8	GND
K9	GND
K10	GND
K11	VCC
K12	VCCIB1
K13	IO95NPB1
K14	IO100NPB1
K15	IO102NDB1
K16	IO102PDB1
L1	IO202NDB3
L2	IO202PDB3
L3	IO196PPB3
L4	IO193PPB3
L5	VCCIB3
L6	GND
L7	VCC
L8	VCC
L9	VCC
L10	VCC
L11	GND
L12	VCCIB1
L13	GDB0/IO112NPB1
L14	IO106NDB1
L15	IO106PDB1
L16	IO107PDB1
M1	IO197NSB3
M2	IO196NPB3
M3	IO193NPB3
M4	GEC0/IO190NPB3

FG256	
Pin Number	A3P1000 Function
M5	VMV3
M6	VCCIB2
M7	VCCIB2
M8	IO147RSB2
M9	IO136RSB2
M10	VCCIB2
M11	VCCIB2
M12	VMV2
M13	IO110NDB1
M14	GDB1/IO112PPB1
M15	GDC1/IO111PDB1
M16	IO107NDB1
N1	IO194PSB3
N2	IO192PPB3
N3	GEC1/IO190PPB3
N4	IO192NPB3
N5	GNDQ
N6	GEA2/IO187RSB2
N7	IO161RSB2
N8	IO155RSB2
N9	IO141RSB2
N10	IO129RSB2
N11	IO124RSB2
N12	GNDQ
N13	IO110PDB1
N14	VJTAG
N15	GDC0/IO111NDB1
N16	GDA1/IO113PDB1
P1	GEB1/IO189PDB3
P2	GEB0/IO189NDB3
P3	VMV2
P4	IO179RSB2
P5	IO171RSB2
P6	IO165RSB2
P7	IO159RSB2
P8	IO151RSB2

FG256	
Pin Number	A3P1000 Function
P9	IO137RSB2
P10	IO134RSB2
P11	IO128RSB2
P12	VMV1
P13	TCK
P14	VPUMP
P15	TRST
P16	GDA0/IO113NDB1
R1	GEA1/IO188PDB3
R2	GEA0/IO188NDB3
R3	IO184RSB2
R4	GEC2/IO185RSB2
R5	IO168RSB2
R6	IO163RSB2
R7	IO157RSB2
R8	IO149RSB2
R9	IO143RSB2
R10	IO138RSB2
R11	IO131RSB2
R12	IO125RSB2
R13	GDB2/IO115RSB2
R14	TDI
R15	GNDQ
R16	TDO
T1	GND
T2	IO183RSB2
T3	GEB2/IO186RSB2
T4	IO172RSB2
T5	IO170RSB2
T6	IO164RSB2
T7	IO158RSB2
T8	IO153RSB2
T9	IO142RSB2
T10	IO135RSB2
T11	IO130RSB2
T12	GDC2/IO116RSB2

FG256	
Pin Number	A3P1000 Function
T13	IO120RSB2
T14	GDA2/IO114RSB2
T15	TMS
T16	GND

FG484

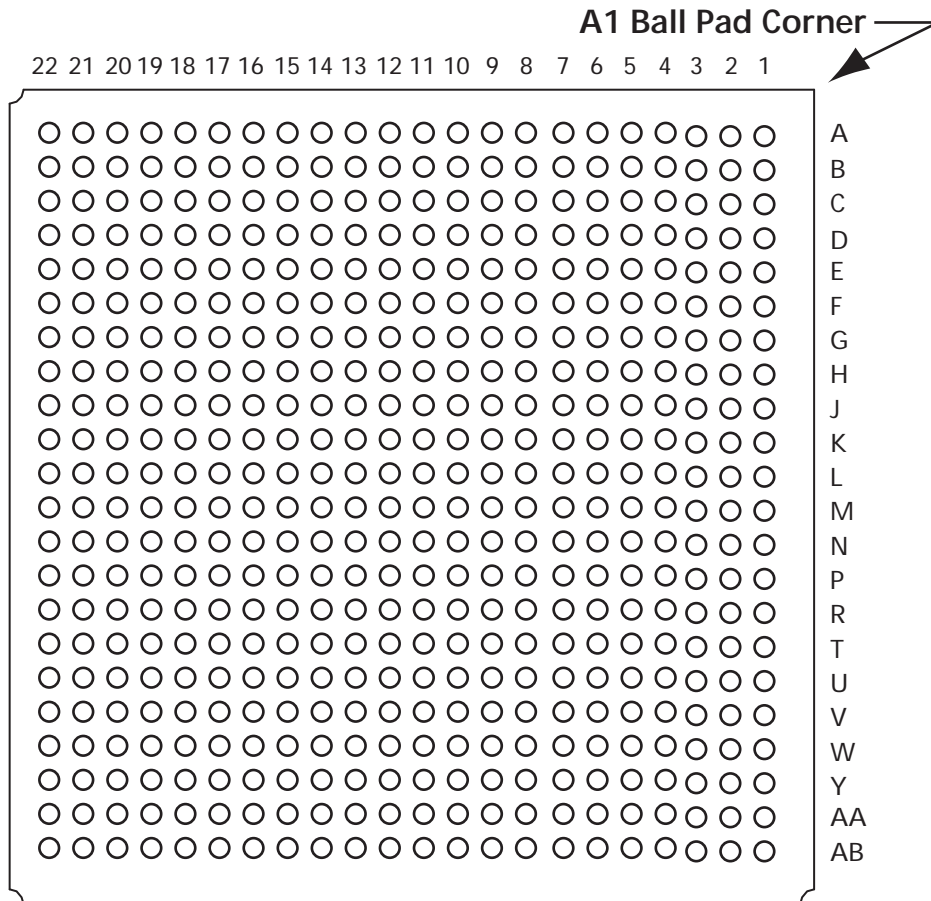

Note: This is the bottom view of the package.

Note

For Package Manufacturing and Environmental information, visit the Resource Center at <http://www.actel.com/products/solutions/package/docs.aspx>.

FG484	
Pin Number	A3P1000 Function
A1	GND
A2	GND
A3	VCCIB0
A4	IO07RSB0
A5	IO09RSB0
A6	IO13RSB0
A7	IO18RSB0
A8	IO20RSB0
A9	IO26RSB0
A10	IO32RSB0
A11	IO40RSB0
A12	IO41RSB0
A13	IO53RSB0
A14	IO59RSB0
A15	IO64RSB0
A16	IO65RSB0
A17	IO67RSB0
A18	IO69RSB0
A19	NC
A20	VCCIB0
A21	GND
A22	GND
B1	GND
B2	VCCIB3
B3	NC
B4	IO06RSB0
B5	IO08RSB0
B6	IO12RSB0
B7	IO15RSB0
B8	IO19RSB0
B9	IO24RSB0
B10	IO31RSB0
B11	IO39RSB0
B12	IO48RSB0
B13	IO54RSB0
B14	IO58RSB0

FG484	
Pin Number	A3P1000 Function
B15	IO63RSB0
B16	IO66RSB0
B17	IO68RSB0
B18	IO70RSB0
B19	NC
B20	NC
B21	VCCIB1
B22	GND
C1	VCCIB3
C2	IO220PDB3
C3	NC
C4	NC
C5	GND
C6	IO10RSB0
C7	IO14RSB0
C8	VCC
C9	V _{CC}
C10	IO30RSB0
C11	IO37RSB0
C12	IO43RSB0
C13	NC
C14	VCC
C15	VCC
C16	NC
C17	NC
C18	GND
C19	NC
C20	NC
C21	NC
C22	VCCIB1
D1	IO219PDB3
D2	IO220NDB3
D3	NC
D4	GND
D5	GAA0/IO00RSB0
D6	GAA1/IO01RSB0

FG484	
Pin Number	A3P1000 Function
D7	GAB0/IO02RSB0
D8	IO16RSB0
D9	IO22RSB0
D10	IO28RSB0
D11	IO35RSB0
D12	IO45RSB0
D13	IO50RSB0
D14	IO55RSB0
D15	IO61RSB0
D16	GBB1/IO75RSB0
D17	GBA0/IO76RSB0
D18	GBA1/IO77RSB0
D19	GND
D20	NC
D21	NC
D22	NC
E1	IO219NDB3
E2	NC
E3	GND
E4	GAB2/IO224PDB3
E5	GAA2/IO225PDB3
E6	GNDQ
E7	GAB1/IO03RSB0
E8	IO17RSB0
E9	IO21RSB0
E10	IO27RSB0
E11	IO34RSB0
E12	IO44RSB0
E13	IO51RSB0
E14	IO57RSB0
E15	GBC1/IO73RSB0
E16	GBB0/IO74RSB0
E17	IO71RSB0
E18	GBA2/IO78PDB1
E19	IO81PDB1
E20	GND

FG484	
Pin Number	A3P1000 Function
E21	NC
E22	IO84PDB1
F1	NC
F2	IO215PDB3
F3	IO215NDB3
F4	IO224NDB3
F5	IO225NDB3
F6	VMV3
F7	IO11RSB0
F8	GAC0/IO04RSB0
F9	GAC1/IO05RSB0
F10	IO25RSB0
F11	IO36RSB0
F12	IO42RSB0
F13	IO49RSB0
F14	IO56RSB0
F15	GBC0/IO72RSB0
F16	IO62RSB0
F17	VMV0
F18	IO78NDB1
F19	IO81NDB1
F20	IO82PPB1
F21	NC
F22	IO84NDB1
G1	IO214NDB3
G2	IO214PDB3
G3	NC
G4	IO222NDB3
G5	IO222PDB3
G6	GAC2/IO223PDB3
G7	IO223NDB3
G8	GNDQ
G9	IO23RSB0
G10	IO29RSB0
G11	IO33RSB0
G12	IO46RSB0

FG484	
Pin Number	A3P1000 Function
G13	IO52RSB0
G14	IO60RSB0
G15	GNDQ
G16	IO80NDB1
G17	GBB2/IO79PDB1
G18	IO79NDB1
G19	IO82NPB1
G20	IO85PDB1
G21	IO85NDB1
G22	NC
H1	NC
H2	NC
H3	V _{CC}
H4	IO217PDB3
H5	IO218PDB3
H6	IO221NDB3
H7	IO221PDB3
H8	VMV0
H9	V _{CCI} B0
H10	V _{CCI} B0
H11	IO38RSB0
H12	IO47RSB0
H13	VCCIB0
H14	VCCIB0
H15	VMV1
H16	GBC2/IO80PDB1
H17	IO83PPB1
H18	IO86PPB1
H19	IO87PDB1
H20	VCC
H21	NC
H22	NC
J1	IO212NDB3
J2	IO212PDB3
J3	NC
J4	IO217NDB3

FG484	
Pin Number	A3P1000 Function
J5	IO218NDB3
J6	IO216PDB3
J7	IO216NDB3
J8	VCCIB3
J9	GND
J10	VCC
J11	VCC
J12	VCC
J13	VCC
J14	GND
J15	VCCIB1
J16	IO83NPB1
J17	IO86NPB1
J18	IO90PPB1
J19	IO87NDB1
J20	NC
J21	IO89PDB1
J22	IO89NDB1
K1	IO211PDB3
K2	IO211NDB3
K3	NC
K4	IO210PPB3
K5	IO213NDB3
K6	IO213PDB3
K7	GFC1/IO209PPB3
K8	VCCIB3
K9	V _{CC}
K10	GND
K11	GND
K12	GND
K13	GND
K14	VCC
K15	VCCIB1
K16	GCC1/IO91PPB1
K17	IO90NPB1
K18	IO88PDB1

FG484	
Pin Number	A3P1000 Function
K19	IO88NDB1
K20	IO94NPB1
K21	IO98NDB1
K22	IO98PDB1
L1	NC
L2	IO200PDB3
L3	IO210NPB3
L4	GFB0/IO208NPB3
L5	GFA0/IO207NDB3
L6	GFB1/IO208PPB3
L7	VCOMPLF
L8	GFC0/IO209NPB3
L9	VCC
L10	GND
L11	GND
L12	GND
L13	GND
L14	VCC
L15	GCC0/IO91NPB1
L16	GCB1/IO92PPB1
L17	GCA0/IO93NPB1
L18	IO96NPB1
L19	GCB0/IO92NPB1
L20	IO97PDB1
L21	IO97NDB1
L22	IO99NPB1
M1	NC
M2	IO200NDB3
M3	IO206NDB3
M4	GFA2/IO206PDB3
M5	GFA1/IO207PDB3
M6	VCCPLF
M7	IO205NDB3
M8	GFB2/IO205PDB3
M9	VCC
M10	GND

FG484	
Pin Number	A3P1000 Function
M11	GND
M12	GND
M13	GND
M14	VCC
M15	GCB2/IO95PPB1
M16	GCA1/IO93PPB1
M17	GCC2/IO96PPB1
M18	IO100PPB1
M19	GCA2/IO94PPB1
M20	IO101PPB1
M21	IO99PPB1
M22	NC
N1	IO201NDB3
N2	IO201PDB3
N3	NC
N4	GFC2/IO204PDB3
N5	IO204NDB3
N6	IO203NDB3
N7	IO203PDB3
N8	VCCIB3
N9	VCC
N10	GND
N11	GND
N12	GND
N13	GND
N14	VCC
N15	VCCIB1
N16	IO95NPB1
N17	IO100NPB1
N18	IO102NDB1
N19	IO102PDB1
N20	NC
N21	IO101NPB1
N22	IO103PDB1
P1	NC
P2	IO199PDB3

FG484	
Pin Number	A3P1000 Function
P3	IO199NDB3
P4	IO202NDB3
P5	IO202PDB3
P6	IO196PPB3
P7	IO193PPB3
P8	VCCIB3
P9	GND
P10	VCC
P11	VCC
P12	VCC
P13	VCC
P14	GND
P15	VCCIB1
P16	GDB0/IO112NPB1
P17	IO106NDB1
P18	IO106PDB1
P19	IO107PDB1
P20	NC
P21	IO104PDB1
P22	IO103NDB1
R1	NC
R2	IO197PPB3
R3	VCC
R4	IO197NPB3
R5	IO196NPB3
R6	IO193NPB3
R7	GEC0/IO190NPB3
R8	VMV3
R9	VCCIB2
R10	VCCIB2
R11	IO147RSB2
R12	IO136RSB2
R13	VCCIB2
R14	VCCIB2
R15	VMV2
R16	IO110NDB1

FG484	
Pin Number	A3P1000 Function
R17	GDB1/IO112PPB1
R18	GDC1/IO111PDB1
R19	IO107NDB1
R20	VCC
R21	IO104NDB1
R22	IO105PDB1
T1	IO198PDB3
T2	IO198NDB3
T3	NC
T4	IO194PPB3
T5	IO192PPB3
T6	GEC1/IO190PPB3
T7	IO192NPB3
T8	GNDQ
T9	GEA2/IO187RSB2
T10	IO161RSB2
T11	IO155RSB2
T12	IO141RSB2
T13	IO129RSB2
T14	IO124RSB2
T15	GNDQ
T16	IO110PDB1
T17	VJTAG
T18	GDC0/IO111NDB1
T19	GDA1/IO113PDB1
T20	NC
T21	IO108PDB1
T22	IO105NDB1
U1	IO195PDB3
U2	IO195NDB3
U3	IO194NPB3
U4	GEB1/IO189PDB3
U5	GEB0/IO189NDB3
U6	VMV2
U7	IO179RSB2
U8	IO171RSB2

FG484	
Pin Number	A3P1000 Function
U9	IO165RSB2
U10	IO159RSB2
U11	IO151RSB2
U12	IO137RSB2
U13	IO134RSB2
U14	IO128RSB2
U15	VMV1
U16	TCK
U17	VPUMP
U18	TRST
U19	GDA0/IO113NDB1
U20	NC
U21	IO108NDB1
U22	IO109PDB1
V1	NC
V2	NC
V3	GND
V4	GEA1/IO188PDB3
V5	GEA0/IO188NDB3
V6	IO184RSB2
V7	GEC2/IO185RSB2
V8	IO168RSB2
V9	IO163RSB2
V10	IO157RSB2
V11	IO149RSB2
V12	IO143RSB2
V13	IO138RSB2
V14	IO131RSB2
V15	IO125RSB2
V16	GDB2/IO115RSB2
V17	TDI
V18	GNDQ
V19	TDO
V20	GND
V21	NC
V22	IO109NDB1

FG484	
Pin Number	A3P1000 Function
W1	NC
W2	IO191PDB3
W3	NC
W4	GND
W5	IO183RSB2
W6	GEB2/IO186RSB2
W7	IO172RSB2
W8	IO170RSB2
W9	IO164RSB2
W10	IO158RSB2
W11	IO153RSB2
W12	IO142RSB2
W13	IO135RSB2
W14	IO130RSB2
W15	GDC2/IO116RSB2
W16	IO120RSB2
W17	GDA2/IO114RSB2
W18	TMS
W19	GND
W20	NC
W21	NC
W22	NC
Y1	VCCIB3
Y2	IO191NDB3
Y3	NC
Y4	IO182RSB2
Y5	GND
Y6	IO177RSB2
Y7	IO174RSB2
Y8	VCC
Y9	VCC
Y10	IO154RSB2
Y11	IO148RSB2
Y12	IO140RSB2
Y13	NC
Y14	VCC

FG484	
Pin Number	A3P1000 Function
Y15	VCC
Y16	NC
Y17	NC
Y18	GND
Y19	NC
Y20	NC
Y21	NC
Y22	VCCIB1
AA1	GND
AA2	VCCIB3
AA3	NC
AA4	IO181RSB2
AA5	IO178RSB2
AA6	IO175RSB2
AA7	IO169RSB2
AA8	IO166RSB2
AA9	IO160RSB2
AA10	IO152RSB2
AA11	IO146RSB2
AA12	IO139RSB2
AA13	IO133RSB2
AA14	NC
AA15	NC
AA16	IO122RSB2
AA17	IO119RSB2
AA18	IO117RSB2
AA19	NC
AA20	NC
AA21	VCCIB1
AA22	GND
AB1	GND
AB2	GND
AB3	VCCIB2
AB4	IO180RSB2
AB5	IO176RSB2
AB6	IO173RSB2

FG484	
Pin Number	A3P1000 Function
AB7	IO167RSB2
AB8	IO162RSB2
AB9	IO156RSB2
AB10	IO150RSB2
AB11	IO145RSB2
AB12	IO144RSB2
AB13	IO132RSB2
AB14	IO127RSB2
AB15	IO126RSB2
AB16	IO123RSB2
AB17	IO121RSB2
AB18	IO118RSB2
AB19	NC
AB20	VCCIB2
AB21	GND
AB22	GND

5 – Datasheet Information

List of Changes

The following table lists critical changes that were made in each revision of the Automotive ProASIC3 datasheet.

Revision	Changes	Page
Revision 5 (January 2013)	The "Automotive ProASIC3 Ordering Information" section has been updated to mention "Y" as "Blank" mentioning "Device Does Not Include License to Implement IP Based on the Cryptography Research, Inc. (CRI) Patent Portfolio" (SAR 43222).	1-III
	Added a note to Table 2-2 • Recommended Operating Conditions (SAR 43675): The programming temperature range supported is $T_{\text{ambient}} = 0^{\circ}\text{C}$ to 85°C .	2-2
	The note in Table 2-116 • Automotive ProASIC3 CCC/PLL Specification referring the reader to SmartGen was revised to refer instead to the online help associated with the core (SAR 42560).	2-80
	Live at Power-Up (LAPU) has been replaced with 'Instant On'.	NA
Revision 4 (September 2012)	The "Specifying I/O States During Programming" section is new (SAR 34691).	1-6
	Table 2-2 • Recommended Operating Conditions was revised to change VPUMP values for programming mode from "3.0 to 3.6" to "3.15 to 3.45" (SAR 34703).	2-2
	Maximum values for VIL and VIH were corrected in LVPECL Table 2-86 • Minimum and Maximum DC Input and Output Levels (SAR 37693).	2-52
	Values were added for F_{DDRIMAX} and F_{DDOMAX} in the following tables (SAR 34804): Table 2-99 • Input DDR Propagation Delays ($T_J = 135^{\circ}\text{C}$) Table 2-100 • Input DDR Propagation Delays ($T_J = 115^{\circ}\text{C}$) Table 2-102 • Output DDR Propagation Delays ($T_J = 135^{\circ}\text{C}$) Table 2-103 • Output DDR Propagation Delays ($T_J = 115^{\circ}\text{C}$)	2-64 to 2-68
	Added values for minimum pulse width and removed the FRMAX row from Table 2-108 through Table 2-115 in the "Global Tree Timing Characteristics" section. Use the software to determine the FRMAX for the device you are using (SAR 36966).	2-76
	SRAM collision data was added to Table 2-117 • RAM4K9 through Table 2-120 • RAM512X18 . Maximum frequency, F_{MAX} , was updated in Table 2-118 • RAM512X18 (SAR 40859).	2-86 to 2-89
	The "VMVx I/O Supply Voltage (quiet)" section was revised. The sentence, "Within the package, the VMV plane is decoupled from the simultaneous switching noise originating from the output buffer VCCI domain" was replaced with, "Within the package, the VMV plane biases the input stage of the I/Os in the I/O banks" (SAR 38323). VMV pins must be connected to the corresponding VCCI pins, as noted in the "VMVx I/O Supply Voltage (quiet)" section, for an ESD enhancement.	3-1
	Libero Integrated Design Environment (IDE) was changed to Libero System-on-Chip (SoC) throughout the document (SAR 40266).	N/A
Revision 3 (September 2012)	The "Security" section was modified to clarify that Microsemi does not support read-back of programmed data.	1-1

Revision	Changes	Page
Revision 2 (May 2012)	The "Extended Temperature AEC-Q100–Qualified Devices" section was modified to include the low end of the temperature range, –40°C, for Grade 1 and Grade 2 AEC-Q100 qualified devices (SAR 34915).	I
	The "In-System Programming (ISP) and Security" section and "Security" section were revised to clarify that although no existing security measures can give an absolute guarantee, Microsemi FPGAs implement the best security available in the industry (SAR 34674).	I, 1-1
	The Y security option and Licensed DPA Logo were added to the "Automotive ProASIC3 Ordering Information" section. The trademarked Licensed DPA Logo identifies that a product is covered by a DPA counter-measures license from Cryptography Research (SAR 34719).	III
	A note defining T_A and T_J was added to the "Automotive ProASIC3 Ordering Information" section (SAR 37547).	III
	The following sentence was deleted from the "Advanced Architecture" section: "In addition, extensive on-chip programming circuitry allows for rapid, single-voltage (3.3 V) programming of Automotive ProASIC3 devices via an IEEE 1532 JTAG interface" (SAR 34682).	1-3
	In Table 2-2 • Recommended Operating Conditions, VCCPLL analog power supply (PLL) was changed from "1.4 to 1.6" to "1.425 to 1.575" (SAR 34718).	2-2
	The reference to guidelines for global spines and VersaTile rows, given in the "Global Clock Contribution—PCLOCK" section, was corrected to the "Spine Architecture" section of the Global Resources chapter in the <i>Automotive ProASIC3 FPGA Fabric User's Guide</i> (SAR 34738).	2-10
	t_{DOUT} was corrected to t_{DIN} in Figure 2-4 • Input Buffer Timing Model and Delays (example) (SAR 37111).	2-13
	The equations in the notes for Table 2-27 • I/O Weak Pull-Up/Pull-Down Resistances were corrected (SAR 34754).	2-23
	The AC Loading figures in the "Single-Ended I/O Characteristics" section were updated to match tables in the "Summary of I/O Timing Characteristics – Default I/O Software Settings" section (SAR 34882).	2-27
	The following sentence was deleted from the "2.5 V LVCMOS" section (SAR 34795): "It uses a 5 V–tolerant input buffer and push-pull output buffer."	2-33
	The table notes for Table 2-82 • Minimum and Maximum DC Input and Output Levels were not necessary and were removed (SAR 34811).	2-50
	The following figures were deleted (SAR 29991). Reference was made to a new application note, <i>Simultaneous Read-Write Operations in Dual-Port SRAM for Flash-Based cSoCs and FPGAs</i> , which covers these cases in detail (SAR 34861). Figure 2-35 • Write Access after Write to Same Address Figure 2-36 • Read Access after Write to Same Address Figure 2-35 • Read Access after Write to Same Address The port names in the SRAM "Timing Waveforms", SRAM "Timing Characteristics" tables, Figure 2-39 • FIFO Reset, and the FIFO "Timing Characteristics" tables were revised to ensure consistency with the software names (SAR 35744).	2-83, 2-86, 2-92, 2-94
	Figure 2-37 • FIFO Read and Figure 2-38 • FIFO Write are new (SAR 34838).	2-91
Table 2-116 • Automotive ProASIC3 CCC/PLL Specification was updated. A note was added to indicate that when the CCC/PLL core is generated by Microsemi core generator software, not all delay values of the specified delay increments are available (SAR 34822).	2-80	

Revision	Changes	Page
Revision 2 (continued)	The "Pin Descriptions and Packaging" chapter has been added (SAR 34767),	3-1
	The "VQ100" pin table for A3P125 has been added (SAR 37944).	4-3
	Package names used in the "Package Pin Assignments" section were revised to match standards given in <i>Package Mechanical Drawings</i> (SAR 34767).	4-1
July 2010	The versioning system for datasheets has been changed. Datasheets are assigned a revision number that increments each time the datasheet is revised. The "Automotive ProASIC3 Device Status" table on page II indicates the status for each device in the device family.	N/A

Revision	Changes	Page
Revision 1 (Dec 2009) Product Brief v1.1 Packaging v1.1	The QNG132 package was added to the "Automotive ProASIC3 Product Family" table, "I/Os Per Package" table, "Automotive ProASIC3 Ordering Information", and "Temperature Grade Offerings".	I – IV
	Pin tables for A3P125 and A3P250 were added for the "QN132" package.	4-6

Datasheet Categories

Categories

In order to provide the latest information to designers, some datasheet parameters are published before data has been fully characterized from silicon devices. The data provided for a given device, as highlighted in the "[Automotive ProASIC3 Device Status](#)" table on page II, is designated as either "Product Brief," "Advance," "Preliminary," or "Production." The definitions of these categories are as follows:

Product Brief

The product brief is a summarized version of a datasheet (advance or production) and contains general product information. This document gives an overview of specific device and family information.

Advance

This version contains initial estimated information based on simulation, other products, devices, or speed grades. This information can be used as estimates, but not for production. This label only applies to the DC and Switching Characteristics chapter of the datasheet and will only be used when the data has not been fully characterized.

Preliminary

The datasheet contains information based on simulation and/or initial characterization. The information is believed to be correct, but changes are possible.

Production

This version contains information that is considered to be final.

Export Administration Regulations (EAR)

The products described in this document are subject to the Export Administration Regulations (EAR). They could require an approved export license prior to export from the United States. An export includes release of product or disclosure of technology to a foreign national inside or outside the United States.

Safety Critical, Life Support, and High-Reliability Applications Policy

The products described in this advance status document may not have completed the Microsemi qualification process. Products may be amended or enhanced during the product introduction and qualification process, resulting in changes in device functionality or performance. It is the responsibility of each customer to ensure the fitness of any product (but especially a new product) for a particular purpose, including appropriateness for safety-critical, life-support, and other high-reliability applications. Consult the Microsemi SoC Products Group Terms and Conditions for specific liability exclusions relating to life-support applications. A reliability report covering all of the SoC Products Group's products is available at http://www.microsemi.com/soc/documents/ORT_Report.pdf. Microsemi also offers a variety of enhanced qualification and lot acceptance screening procedures. Contact your local sales office for additional reliability information.



Microsemi Corporate Headquarters
One Enterprise, Aliso Viejo CA 92656 USA
Within the USA: +1 (949) 380-6100
Sales: +1 (949) 380-6136
Fax: +1 (949) 215-4996

Microsemi Corporation (NASDAQ: MSCC) offers a comprehensive portfolio of semiconductor solutions for: aerospace, defense and security; enterprise and communications; and industrial and alternative energy markets. Products include high-performance, high-reliability analog and RF devices, mixed signal and RF integrated circuits, customizable SoCs, FPGAs, and complete subsystems. Microsemi is headquartered in Aliso Viejo, Calif. Learn more at www.microsemi.com.

© 2012 Microsemi Corporation. All rights reserved. Microsemi and the Microsemi logo are trademarks of Microsemi Corporation. All other trademarks and service marks are the property of their respective owners.

Looking for pricing, stock, or lifecycle information?

Click below to explore more details on WIN SOURCE:

- ⊖ [View A3P1000-FGG256T on WIN SOURCE](#)
- ⊖ [Microchip Technology](#) Information

Optimize Your Supply Chain with WIN SOURCE Solutions

- ✓ Global Sourcing Solution
- ✓ Obsolete Management
- ✓ Cost Control Management
- ✓ Shortage Management
- ✓ Alternative Solution
- ✓ Excess Inventory Management