



**THE DATASHEET OF  
DFBR030U3LP-13**



## Features

- Dual 30V N-Channel MOSFETs (Q1, Q2) with Dual 3.0A Super Barrier Rectifier Diodes (D1, D2) packaged in a 4.0 x 4.0 x 0.6mm DFN package
- Full-Bridge Rectifier Block
- Super Barrier Rectifiers (D1, D2)
  - Ultra low forward voltage drop
  - Patented Super Barrier Rectifier technology
  - +150°C operating temperature
  - ±8kV ESD protection (HBM, 3B)
  - ±25kV ESD protection (IEC61000-4-2 Level 4, Air Discharge)
- N-Channel MOSFET (Q1, Q2)
  - Low On-Resistance to minimize conduction loss
  - Low Gate Threshold Voltage
  - Low Input Capacitance
  - Fast Switching Speed
  - Low Input/Output Leakage
- **Totally Lead-Free & Fully RoHS Compliant (Notes 1 & 2)**
- **Halogen and Antimony Free. "Green" Device (Note 3)**

## Mechanical Data

- Case: U-DFN4040-8
- Case Material: Molded Plastic, "Green" Molding Compound; UL Flammability Classification Rating 94V-0
- Moisture Sensitivity: Level 1 per J-STD-020
- Terminals: NiPdAu over Copper Leadframe (Lead-Free Plating); Solderable per MIL-STD-202, Method 208④
- Terminal Connections: See Diagram
- Weight: 0.031 grams

## Applications

- Wireless Charging
- AC-DC Rectification
- Optimized for Power Management Applications for Portable Products

U-DFN4040-8

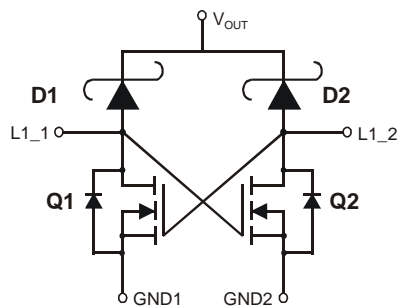

Device Schematic (Dual Channel)

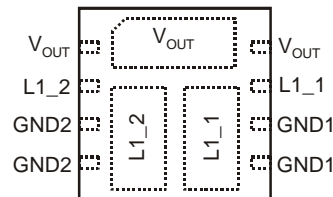
 Top View  
Pin Configuration

## Ordering Information (Note 4)

Part Number	Compliance	Case	Packaging
DFBR030U3LP-13	Standard	U-DFN4040-8	4,000/Tape & Reel

- Notes:
1. No purposely added lead. Fully EU Directive 2002/95/EC (RoHS) & 2011/65/EU (RoHS 2) compliant.
  2. See [http://www.diodes.com/quality/lead\\_free.html](http://www.diodes.com/quality/lead_free.html) for more information about Diodes Incorporated's definitions of Halogen- and Antimony-free, "Green" and Lead-free.
  3. Halogen- and Antimony-free "Green" products are defined as those which contain <900ppm bromine, <900ppm chlorine (<1500ppm total Br + Cl) and <1000ppm antimony compounds.
  4. For packaging details, go to our website at <http://www.diodes.com/products/packages.html>.

## Marking Information

U-DFN4040-8



FB302 = Product Type Marking Code  
 YYWW = Date Code Marking  
 YY = Last Digit of Year (ex: 15 for 2015)  
 WW = Week Code (01 to 53)

**Maximum Ratings – D1, D2** (@T<sub>A</sub> = +25°C, unless otherwise specified.)

Single phase, half wave, 60Hz, resistive or inductive load.  
For capacitance load, derate current by 20%.

Characteristic	Symbol	Value	Unit
Peak Repetitive Reverse Voltage	V <sub>RRM</sub>	30	V
Working Peak Reverse Voltage	V <sub>RWM</sub>		
DC Blocking Voltage	V <sub>RM</sub>		
RMS Reverse Voltage	V <sub>R(RMS)</sub>	21	V
Average Rectified Output Current (See Figure 1)	I <sub>O</sub>	3.0	A
Non-Repetitive Peak Forward Surge Current 8.3ms Single Half Sine-Wave Superimposed on Rated Load	I <sub>FSM</sub>	20	A

**Maximum Ratings – Q1, Q2** (@T<sub>A</sub> = +25°C, unless otherwise specified.)

Characteristic	Symbol	Value	Units
Input Voltage Between Two MOSFET Drain	V <sub>LL</sub>	30	V
Drain-Source Voltage	V <sub>DSS</sub>	30	V
Gate-Source Voltage	V <sub>GSS</sub>	±20	V
Drain Current (Note 5)	I <sub>D</sub>	3.2	A

**Thermal Characteristics**

Characteristic	Symbol	Value	Unit
Power Dissipation (Note 5)	P <sub>D</sub>	500	mW
Thermal Resistance, Junction to Ambient Air (Note 5)	R <sub>θJA</sub>	250	°C/W
Power Dissipation (Note 6)	P <sub>D</sub>	1000	mW
Thermal Resistance, Junction to Ambient Air (Note 6)	R <sub>θJA</sub>	125	°C/W
Operating and Storage Temperature Range	T <sub>J</sub> , T <sub>STG</sub>	-55 to +150	°C

**Electrical Characteristics – D1, D2** (@T<sub>A</sub> = +25°C, unless otherwise specified.)

Characteristic	Symbol	Min	Typ	Max	Unit	Test Condition
Reverse Breakdown Voltage (Note 7)	V <sub>(BR)R</sub>	30	—	—	V	I <sub>R</sub> = 400μA
Forward Voltage Drop	V <sub>F</sub>	—	0.25	0.278	V	I <sub>F</sub> = 0.1A, T <sub>J</sub> = +25°C
		—	0.33	0.37		I <sub>F</sub> = 1.0A, T <sub>J</sub> = +25°C
		—	0.36	0.42		I <sub>F</sub> = 2.0A, T <sub>J</sub> = +25°C
		—	0.24	0.27		I <sub>F</sub> = 0.1A, T <sub>J</sub> = +125°C
		—	0.33	0.36		I <sub>F</sub> = 1.0A, T <sub>J</sub> = +125°C
		—	0.35	0.40		I <sub>F</sub> = 2.0A, T <sub>J</sub> = +125°C
Leakage Current (Note 7)	I <sub>R</sub>	—	50	150	μA	V <sub>R</sub> = 5V, T <sub>J</sub> = +25°C
		—	100	400	μA	V <sub>R</sub> = 30V, T <sub>J</sub> = +25°C
		—	6	15	mA	V <sub>R</sub> = 5V, T <sub>J</sub> = +125°C
		—	10	20	mA	V <sub>R</sub> = 30V, T <sub>J</sub> = +125°C

Notes: 5. Part mounted on FR-4 board with recommended pad layout, which can be found on our website at <http://www.diodes.com>.  
6. Part mounted on FR-4 board with 1-in sq pad layout, 2oz Cu.  
7. Short duration pulse test used to minimize self-heating effect. Pulse width ≤ 300μs, duty cycle ≤ 2%.

**Electrical Characteristics – Q1, Q2** (@T<sub>A</sub> = +25°C, unless otherwise specified.)

Characteristic	Symbol	Min	Typ	Max	Unit	Test Condition
<b>OFF CHARACTERISTICS (Note 7)</b>						
Drain-Source Breakdown Voltage	BV <sub>DSS</sub>	30	—	—	V	V <sub>GS</sub> = 0V, I <sub>D</sub> = 250μA
Zero Gate Voltage Drain Current	I <sub>DSS</sub>	—	—	220	μA	V <sub>DS</sub> = 30V, V <sub>GS</sub> = 0V
Gate-Source Leakage	I <sub>GSS</sub>	—	—	±200	μA	V <sub>GS</sub> = ±20V, V <sub>DS</sub> = 0V
<b>ON CHARACTERISTICS (Note 7)</b>						
Gate Threshold Voltage	V <sub>GS(th)</sub>	1	—	2.2	V	V <sub>DS</sub> = V <sub>GS</sub> , I <sub>D</sub> = 250μA
Static Drain-Source On-Resistance	R <sub>DS(ON)</sub>	—	13	--	mΩ	V <sub>GS</sub> = 10V, I <sub>D</sub> = 2.0A
			17	26		V <sub>GS</sub> = 10V, I <sub>D</sub> = 3.2A
			22	--		V <sub>GS</sub> = 4.5V, I <sub>D</sub> = 2.0A
			23	32		V <sub>GS</sub> = 4.5V, I <sub>D</sub> = 3.2A
Forward Transconductance	g <sub>fs</sub>	—	7	—	S	V <sub>DS</sub> = 15V, I <sub>D</sub> = 2.0A
Diode Forward Voltage (Note 7)	V <sub>SD</sub>	0.5	—	1.2	V	V <sub>GS</sub> = 0V, I <sub>S</sub> = 2.25A

**Electrical Characteristics – DFBR030U3LP** (@T<sub>A</sub> = +25°C, unless otherwise specified.)

Characteristic	Symbol	Min	Typ	Max	Unit	Test Condition
Rectifying Forward Voltage (Note 7)	V <sub>fd2</sub>	—	0.45	0.56	V	Input voltage V <sub>LL</sub> = ±5V; The output current of Rectifier I <sub>OUT</sub> = 2A
Rectifier leakage current	I <sub>leak</sub>	—	30	1000	μA	Input voltage V <sub>LL</sub> = 16V; No Load on the Rectifier output
Rectifier Reverse leakage current	I <sub>rleak</sub>	—	20	1000	μA	Input voltage V <sub>LL</sub> = 0V; The output voltage of the Rectifier V <sub>OUT</sub> = 5V

Note: 7. Short duration pulse test used to minimize self-heating effect. Pulse width ≤ 300μs, duty cycle ≤ 2%.

**Typical Performance Curves – D1, D2**

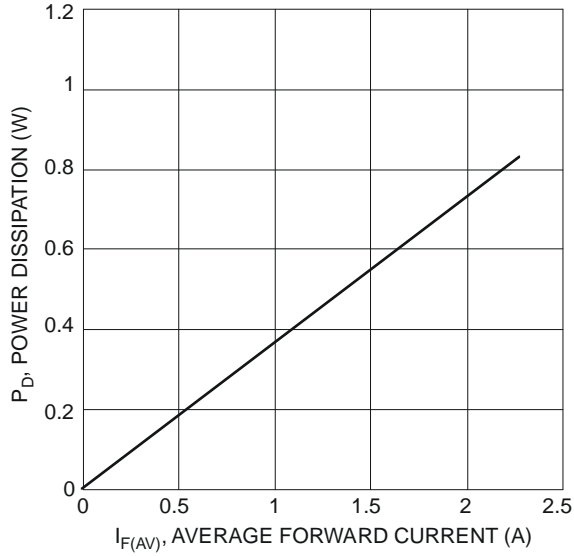

Figure 1 Forward Power Dissipation

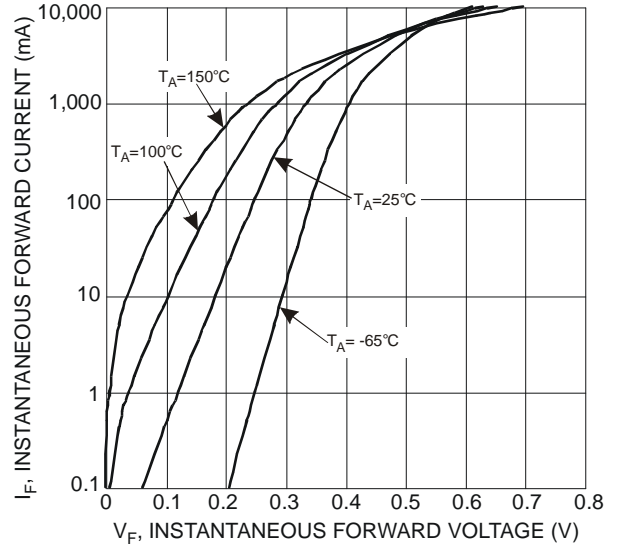

Figure 2 Typical Forward Characteristics

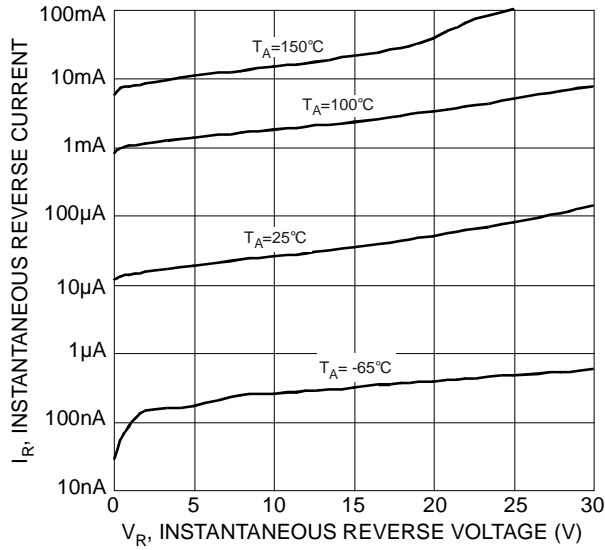

Figure 3 Typical Reverse Characteristics

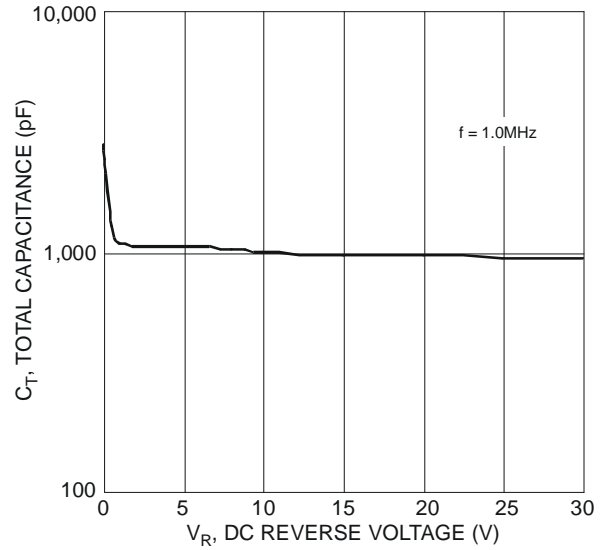

Figure 4 Total Capacitance vs. Reverse Voltage

**Typical Performance Curves – Q1, Q2**

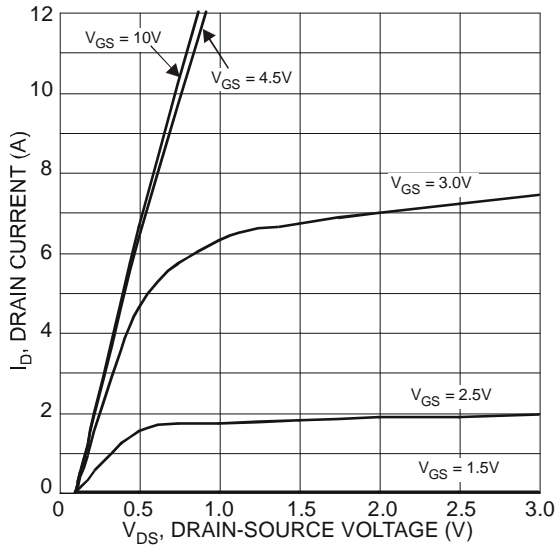

Figure 5 Typical Output Characteristics

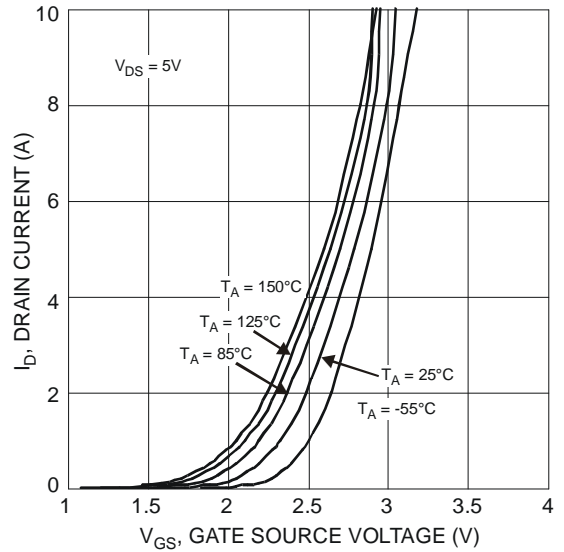

Figure 6 Typical Transfer Characteristics

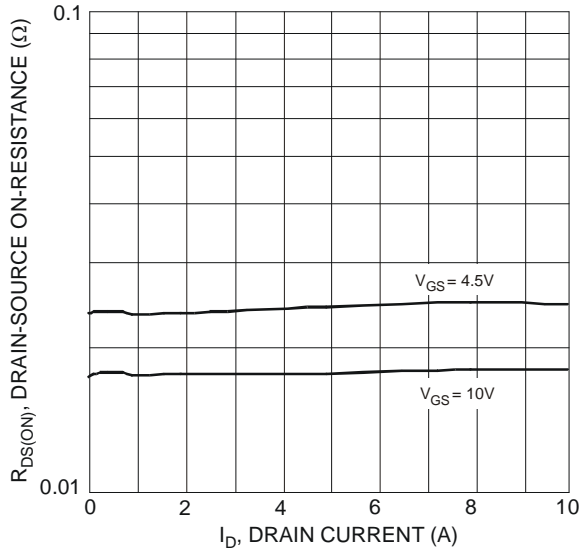

Figure 7 Typical On-Resistance vs. Drain Current and Gate Voltage

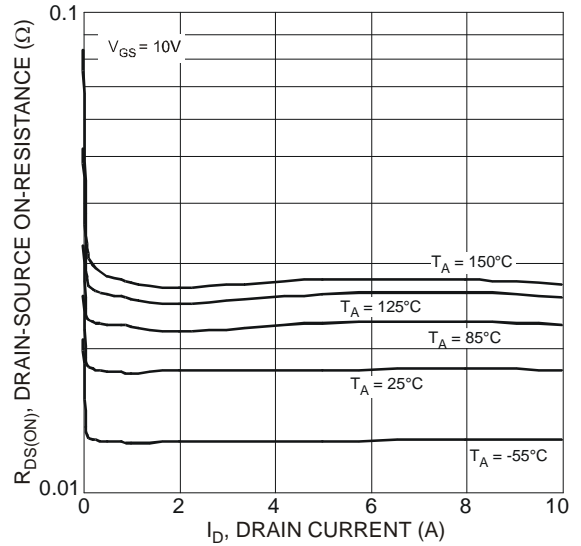

Figure 8 Typical Drain-Source On-Resistance vs. Drain Current and Temperature

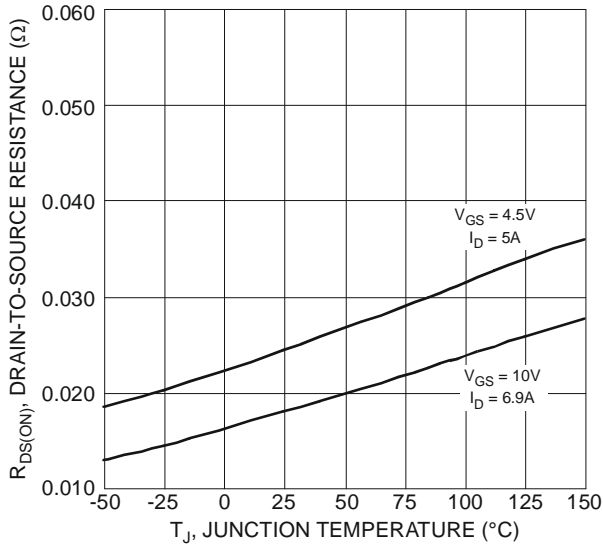

Figure 9 On-Resistance Variation with Temperature

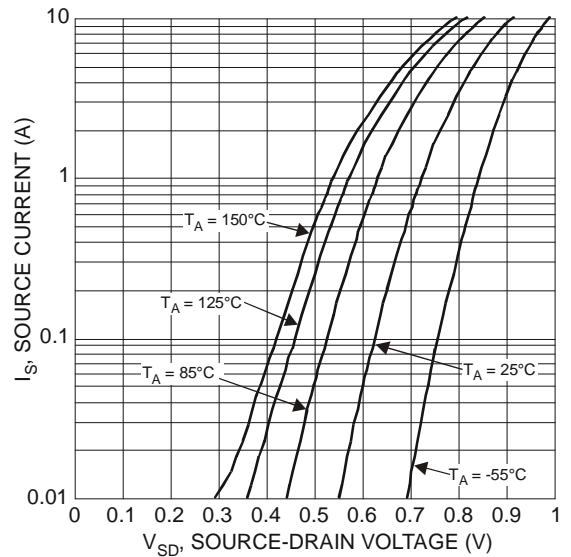

Figure 10 Diode Forward Voltage vs. Current

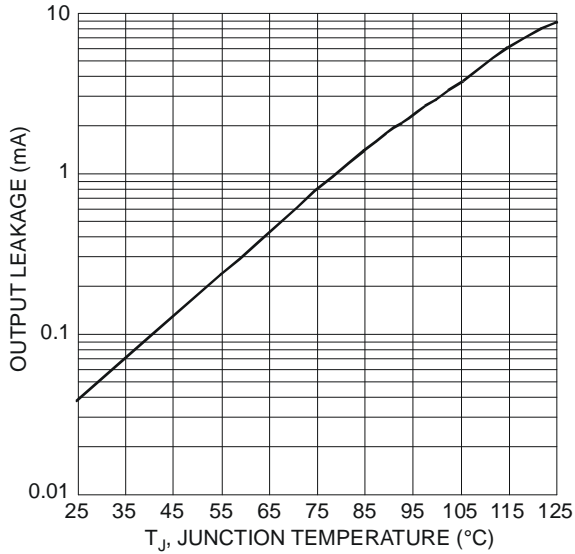

Figure 11 Output Leakage at 5V Bias vs. Junction Temperature

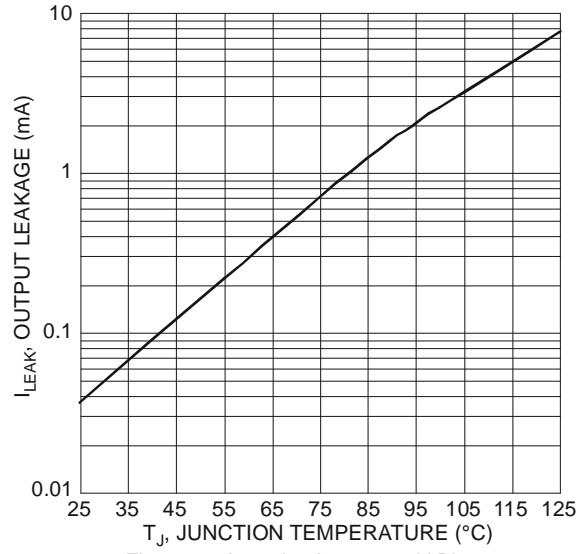

Figure 12 Input Leakage at 16V Bias vs. Junction Temperature

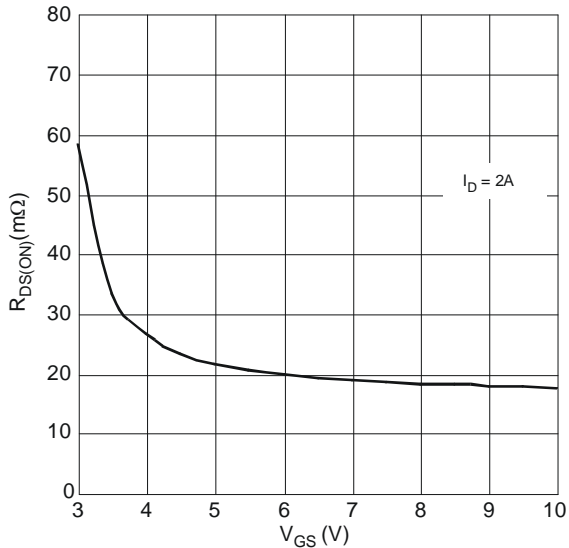

Figure 13 FET Typical On-Resistance vs. Gate-to-Source Voltage (from 3V to 10V)

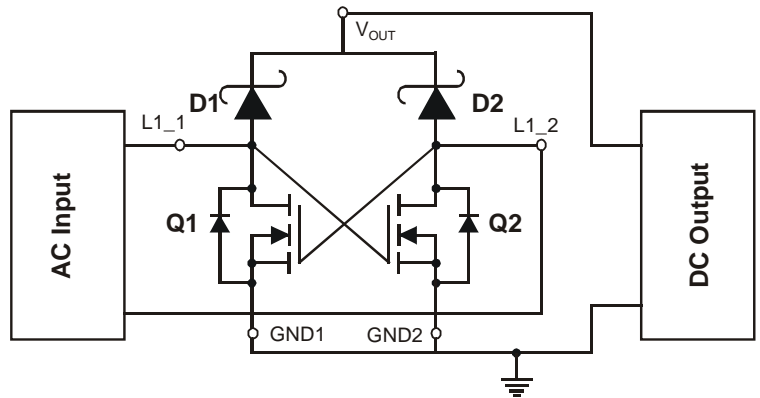
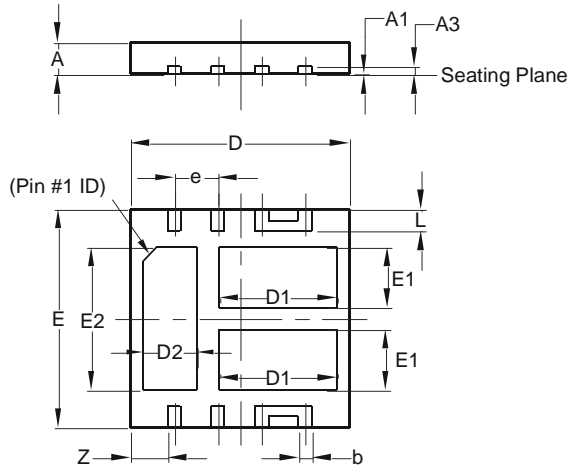

Figure 14 Typical Application Circuit  
GND1 and GND2 are not internally connected.  
The user should make the connection in the PCB design.

**Package Outline Dimensions**

Please see AP02002 at <http://www.diodes.com/datasheets/ap02002.pdf> for the latest version.



U-DFN4040-8			
Dim	Min	Max	Typ
A	0.57	0.63	0.60
A1	0	0.05	0.02
A3	-	-	0.15
b	0.20	0.30	0.25
D	3.95	4.05	4.00
D1	2.05	2.25	2.15
D2	0.90	1.10	1.00
E	3.95	4.05	4.00
E1	1.00	1.20	1.10
E2	2.50	2.70	2.60
e	-	-	0.80
L	0.35	0.45	0.40
Z	-	-	0.675
All Dimensions in mm			

**Suggested Pad Layout**

Please see AP02001 at <http://www.diodes.com/datasheets/ap02001.pdf> for the latest version.

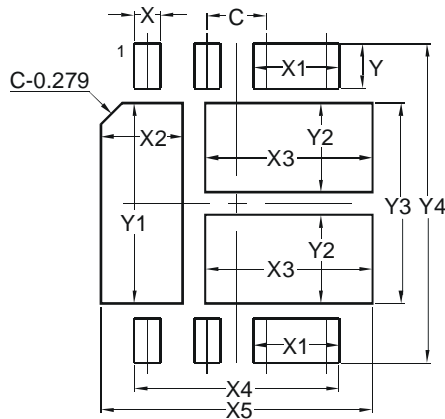

Dimensions	Value (in mm)
C	0.800
X	0.350
X1	1.150
X2	1.100
X3	2.250
X4	2.750
X5	3.650
Y	0.600
Y1	2.700
Y2	1.200
Y3	2.700
Y4	4.300

**IMPORTANT NOTICE**

DIODES INCORPORATED MAKES NO WARRANTY OF ANY KIND, EXPRESS OR IMPLIED, WITH REGARDS TO THIS DOCUMENT, INCLUDING, BUT NOT LIMITED TO, THE IMPLIED WARRANTIES OF MERCHANTABILITY AND FITNESS FOR A PARTICULAR PURPOSE (AND THEIR EQUIVALENTS UNDER THE LAWS OF ANY JURISDICTION).

Diodes Incorporated and its subsidiaries reserve the right to make modifications, enhancements, improvements, corrections or other changes without further notice to this document and any product described herein. Diodes Incorporated does not assume any liability arising out of the application or use of this document or any product described herein; neither does Diodes Incorporated convey any license under its patent or trademark rights, nor the rights of others. Any Customer or user of this document or products described herein in such applications shall assume all risks of such use and will agree to hold Diodes Incorporated and all the companies whose products are represented on Diodes Incorporated website, harmless against all damages.

Diodes Incorporated does not warrant or accept any liability whatsoever in respect of any products purchased through unauthorized sales channel. Should Customers purchase or use Diodes Incorporated products for any unintended or unauthorized application, Customers shall indemnify and hold Diodes Incorporated and its representatives harmless against all claims, damages, expenses, and attorney fees arising out of, directly or indirectly, any claim of personal injury or death associated with such unintended or unauthorized application.

Products described herein may be covered by one or more United States, international or foreign patents pending. Product names and markings noted herein may also be covered by one or more United States, international or foreign trademarks.

This document is written in English but may be translated into multiple languages for reference. Only the English version of this document is the final and determinative format released by Diodes Incorporated.

**LIFE SUPPORT**

Diodes Incorporated products are specifically not authorized for use as critical components in life support devices or systems without the express written approval of the Chief Executive Officer of Diodes Incorporated. As used herein:

A. Life support devices or systems are devices or systems which:

1. are intended to implant into the body, or
2. support or sustain life and whose failure to perform when properly used in accordance with instructions for use provided in the labeling can be reasonably expected to result in significant injury to the user.

B. A critical component is any component in a life support device or system whose failure to perform can be reasonably expected to cause the failure of the life support device or to affect its safety or effectiveness.



Customers represent that they have all necessary expertise in the safety and regulatory ramifications of their life support devices or systems, and acknowledge and agree that they are solely responsible for all legal, regulatory and safety-related requirements concerning their products and any use of Diodes Incorporated products in such safety-critical, life support devices or systems, notwithstanding any devices- or systems-related information or support that may be provided by Diodes Incorporated. Further, Customers must fully indemnify Diodes Incorporated and its representatives against any damages arising out of the use of Diodes Incorporated products in such safety-critical, life support devices or systems.

Copyright © 2015, Diodes Incorporated

[www.diodes.com](http://www.diodes.com)

## Looking for pricing, stock, or lifecycle information?

Click below to explore more details on WIN SOURCE:

-  [View DFBR030U3LP-13 on WIN SOURCE](#)
-  [Diodes Incorporated Information](#)

## Optimize Your Supply Chain with WIN SOURCE Solutions

-  Global Sourcing Solution
-  Obsolete Management
-  Cost Control Management
-  Shortage Management
-  Alternative Solution
-  Excess Inventory Management