



**THE DATASHEET OF
S8FS-G05024CD**



S8FS-G

Ordering Information

List of Models

Note: For details on normal stock models, contact your nearest OMRON representative.

With Cover/DIN Rail Mounting

Power ratings	Input voltage	Output voltage (VDC)	Output current	Built-in fan	Model
15 W	100 to 240 VAC (Permissible range 85 to 264 VAC, 80 to 370 VDC) *4	5 V	3 A	None	S8FS-G01505CD
		12 V	1.3 A		S8FS-G01512CD
		15 V	1 A		S8FS-G01515CD
		24 V	0.65 A		S8FS-G01524CD
30 W		5 V	6 A		S8FS-G03005CD
		12 V	3 A		S8FS-G03012CD
		15 V	2.4 A		S8FS-G03015CD
		24 V	1.5 A		S8FS-G03024CD
50 W		5 V	8 A *1		S8FS-G05005CD
		12 V	4.3 A		S8FS-G05012CD
		15 V	3.5 A		S8FS-G05015CD
		24 V	2.2 A		S8FS-G05024CD
100 W		5 V	16 A *2		S8FS-G10005CD
		12 V	8.5 A		S8FS-G10012CD
		15 V	7 A		S8FS-G10015CD
		24 V	4.5 A		S8FS-G10024CD
150 W	5 V	21 A *3	S8FS-G15005CD		
	12 V	13 A	S8FS-G15012CD		
	15 V	10 A	S8FS-G15015CD		
	24 V	6.5 A	S8FS-G15024CD		
300 W	100 to 240 VAC (Permissible range 85 to 264 VAC, 120 to 370 VDC)	48 V	3.3 A	S8FS-G15048CD	
		12 V	25 A	S8FS-G30012CD	
		15 V	20 A	S8FS-G30015CD	
		24 V	14 A	S8FS-G30024CD	
600 W	100 to 240 VAC (Permissible range 85 to 264 VAC, 120 to 350 VDC)	48 V	7 A	S8FS-G30048CD	
		12 V	50 A	S8FS-G60012CD	
		15 V	40 A	S8FS-G60015CD	
		24 V	27 A	S8FS-G60024CD	
		48 V	13 A	S8FS-G60048CD	

Note: Ask your OMRON representative for pricing information on optional models.

*1. The output electric power is 40 W.

*2. The output electric power is 80 W.

*3. The output electric power is 105 W.

*4. Applicable to products produced from May 2018.

With Cover/DIN Rail Mounting (Extended hold time type)

Power ratings	Input voltage	Output voltage (VDC)	Output current	Built-in fan	Model
300 W	100 to 240 VAC (Permissible range 85 to 264 VAC, 120 to 370 VDC)	24 V	14 A	Yes	S8FS-G30024CD-H
600 W	100 to 240 VAC (Permissible range 85 to 264 VAC, 120 to 350 VDC)		27 A		S8FS-G60024CD-H

With Cover/Direct Mounting

Power ratings	Input voltage	Output voltage (VDC)	Output current	Built-in fan	Model
15 W	100 to 240 VAC (Permissible range 85 to 264 VAC, 80 to 370 VDC) *4	5 V	3 A	None	S8FS-G01505C
		12 V	1.3 A		S8FS-G01512C
		15 V	1 A		S8FS-G01515C
		24 V	0.65 A		S8FS-G01524C
30 W		5 V	6 A		S8FS-G03005C
		12 V	3 A		S8FS-G03012C
		15 V	2.4 A		S8FS-G03015C
		24 V	1.5 A		S8FS-G03024C
50 W		5 V	8 A *1		S8FS-G05005C
		12 V	4.3 A		S8FS-G05012C
		15 V	3.5 A		S8FS-G05015C
		24 V	2.2 A		S8FS-G05024C
100 W		5 V	16 A *2		S8FS-G10005C
		12 V	8.5 A		S8FS-G10012C
		15 V	7 A		S8FS-G10015C
		24 V	4.5 A		S8FS-G10024C
150 W	5 V	21 A *3	S8FS-G15005C		
	12 V	13 A	S8FS-G15012C		
	15 V	10 A	S8FS-G15015C		
	24 V	6.5 A	S8FS-G15024C		
	48 V	3.3 A	S8FS-G15048C		
300 W	100 to 240 VAC (Permissible range 85 to 264 VAC, 120 to 370 VDC)	12 V	25 A	Yes	S8FS-G30012C
		15 V	20 A		S8FS-G30015C
		24 V	14 A		S8FS-G30024C
		48 V	7 A		S8FS-G30048C
600 W	100 to 240 VAC (Permissible range 85 to 264 VAC, 120 to 350 VDC)	12 V	50 A		S8FS-G60012C
		15 V	40 A		S8FS-G60015C
		24 V	27 A		S8FS-G60024C
		48 V	13 A		S8FS-G60048C

Note: 1. Ask your OMRON representative for pricing information on optional models.

2. Front-mounting is not possible.

To mount a Power Supply from the front, purchase a DIN Rail-mounting Power Supply and a Front-mounting Bracket (sold separately). Refer to page 27.

With Cover/Direct Mounting (Extended hold time type)

Power ratings	Input voltage	Output voltage (VDC)	Output current	Built-in fan	Model
300 W	100 to 240 VAC (Permissible range 85 to 264 VAC, 120 to 370 VDC)	24 V	14 A	Yes	S8FS-G30024C-H
600 W	100 to 240 VAC (Permissible range 85 to 264 VAC, 120 to 350 VDC)		27 A		S8FS-G60024C-H

With Cover/Direct Mounting (Connector type)

Power ratings	Input voltage	Output voltage (VDC)	Output current	Built-in fan	Model
15 W	100 to 240 VAC (Permissible range 85 to 264 VAC, 80 to 370 VDC) *4	24 V	0.65 A	None	S8FS-G01524CE
30 W			1.5 A		S8FS-G03024CE
50 W			2.2 A		S8FS-G05024CE
100 W			4.5 A		S8FS-G10024CE
150 W			6.5 A		S8FS-G15024CE

*1. The output electric power is 40 W.

*2. The output electric power is 80 W.

*3. The output electric power is 105 W.

*4. Applicable to products produced from May 2018.

Specifications

Item	Power rating		15 W			
	Output voltage		5 V	12 V	15 V	24 V
Efficiency *	100 VAC input		80% typ.	84% typ.	84% typ.	85% typ.
	200 VAC input		80% typ.	84% typ.	84% typ.	86% typ.
	230 VAC input		80% typ.	84% typ.	84% typ.	86% typ.
Input	Voltage range *		Single phase, 85 to 264 VAC, 80 to 370 VDC			
	Frequency *		50/60 Hz (47 to 450 Hz)			
	Current *	100 VAC input	0.32 A typ.			
		200 VAC input	0.2 A typ.			
	Power factor		---			
	Leakage current *	100 VAC input	0.5 mA max.			
		200 VAC input	1 mA max.			
Inrush current * (for a cold start at 25°C)	100 VAC input	14 A typ.				
	200 VAC input	28 A typ.				
Output	Rated Output Current		3 A	1.3 A	1 A	0.65 A
	Voltage adjustment range *		-10% to 15% (with V.ADJ)			
	Ripple & Noise voltage *	100 to 240 VAC input	40 mVp-p max.	40 mVp-p max.	40 mVp-p max.	60 mVp-p max.
	Input variation influence *		0.5% max.			
	Load variation influence *		1.0% max.			
	Temperature variation influence	100 to 240 VAC input	0.05%/°C max.			
	Startup time *	100 VAC input	1,000 ms max.			
		200 VAC input	1,000 ms max.			
	Hold time *	100 VAC input	15 ms typ.	14 ms typ.	15 ms typ.	15 ms typ.
		200 VAC input	75 ms typ.	70 ms typ.	75 ms typ.	70 ms typ.
Additional functions	Overload protection		Yes, automatic reset			
	Overvoltage protection *		Yes, 120% or higher of rated output voltage, power shut off (shut off the input voltage and turn on the input again)			
	Overheat protection		No			
	Series operation		Yes (For up to two Power Supplies, external diodes are required.)			
	Parallel operation		No (However, backup operation is possible, external diodes are required.)			
	Remote sensing		No			
	Remote control		No			
Output indicator		Yes (LED: Green)				
Insulation	Withstand voltage		3 kVAC for 1 min. (between all input terminals and output terminals) current cutoff 20 mA 2 kVAC for 1 min. (between all input terminals and PE terminals) current cutoff 20 mA 1 kVAC for 1 min. (between all output terminals and PE terminals) current cutoff 20 mA			
	Insulation resistance		100 MΩ min. (between all output terminals and all input terminals/PE terminals) at 500 VDC			
Environment	Ambient operating temperature		-20 to 70°C (Derating is required according to the temperature.) (with no condensation or icing)			
	Storage temperature		-25 to 75°C (with no condensation or icing)			
	Ambient operating humidity		90% max. (Storage humidity: 90% max.)			
	Vibration resistance		10 to 55 Hz, 4.5 G max., 0.375-mm half amplitude for 2 h each in X, Y, and Z directions			
Reliability	Shock resistance		150 m/s ² , 3 times each in ±X, ±Y, ±Z directions			
	MTBF		135,000 hrs min.			
Construction	Life expectancy *		10 years min.			
	Dimensions (W×H×D)		Refer to <i>Dimensions</i> on page 19.			
Standards	Weight		250 g			
	Cooling fan		No			
	Degree of protection		---			
	Harmonic current emissions		Conforms to EN 61000-3-2			
Standards	EMI *	Conducted Emissions	Conforms to EN 61204-3 Class B, EN 55011 Class B			
		Radiated Emissions	Conforms to EN 61204-3 Class B, EN 55011 Class B			
	EMS		Conforms to EN 61204-3 high severity levels			
	Safety Standards		UL 508 (Listing, excluding models with connector option) UL 60950-1, UL 62368-1 (Recognition, OVCII [≤ 3,000 m], Pol2) CSA C22.2 No.107.1 (excluding models with connector option) CSA C22.2 No.60950-1, No.62368-1 (excluding models with connector option) EN 50178 (OVCIII [≤ 2,000 m], OVCII [> 2,000 m and ≤ 3,000 m], Pol2) EN/IEC 60950-1, EN/IEC 62368-1 (OVCII [≤ 3,000 m], Pol2) Conforms to EN/IEC 61558-2-16 Conforms to PELV (EN/IEC 60204-1)			
	Marine Standards		No			
SEMI		Conforms to F47-0706 (200 VAC input)				

* Refer to *Ratings, Characteristics, and Functions* on page 11.

Item	Power rating		30 W			
	Output voltage		5 V	12 V	15 V	24 V
Efficiency *	100 VAC input		81% typ.	84% typ.	86% typ.	86% typ.
	200 VAC input		81% typ.	86% typ.	88% typ.	88% typ.
	230 VAC input		81% typ.	86% typ.	88% typ.	89% typ.
Input	Voltage range *		Single phase, 85 to 264 VAC, 80 to 370 VDC			
	Frequency *		50/60 Hz (47 to 450 Hz)			
	Current *	100 VAC input	0.72 A typ.			
		200 VAC input	0.43 A typ.			
	Power factor		---			
	Leakage current *	100 VAC input	0.5 mA max.			
		200 VAC input	1 mA max.			
Inrush current * (for a cold start at 25°C)	100 VAC input	14 A typ.				
	200 VAC input	28 A typ.				
Output	Rated Output Current		6 A	3 A	2.4 A	1.5 A
	Voltage adjustment range *		-10% to 15% (with V.ADJ)			
	Ripple & Noise voltage *	100 to 240 VAC input	50 mVp-p max.	60 mVp-p max.	50 mVp-p max.	60 mVp-p max.
	Input variation influence *		0.5% max.			
	Load variation influence *		1.0% max.			
	Temperature variation influence	100 to 240 VAC input	0.05%/°C max.			
	Startup time *	100 VAC input	1,000 ms max.			
		200 VAC input	1,000 ms max.			
	Hold time *	100 VAC input	11 ms typ.	10 ms typ.	11 ms typ.	10 ms typ.
		200 VAC input	60 ms typ.	50 ms typ.	50 ms typ.	55 ms typ.
Additional functions	Overload protection		Yes, automatic reset			
	Overvoltage protection *		Yes, 120% or higher of rated output voltage, power shut off (shut off the input voltage and turn on the input again)			
	Overheat protection		No			
	Series operation		Yes (For up to two Power Supplies, external diodes are required.)			
	Parallel operation		No (However, backup operation is possible, external diodes are required.)			
	Remote sensing		No			
	Remote control		No			
Output indicator		Yes (LED: Green)				
Insulation	Withstand voltage		3 kVAC for 1 min. (between all input terminals and output terminals) current cutoff 20 mA 2 kVAC for 1 min. (between all input terminals and PE terminals) current cutoff 20 mA 1 kVAC for 1 min. (between all output terminals and PE terminals) current cutoff 20 mA			
	Insulation resistance		100 MΩ min. (between all output terminals and all input terminals/PE terminals) at 500 VDC			
Environment	Ambient operating temperature		-20 to 70°C (Derating is required according to the temperature.) (with no condensation or icing)			
	Storage temperature		-25 to 75°C (with no condensation or icing)			
	Ambient operating humidity		90% max. (Storage humidity: 90% max.)			
	Vibration resistance		10 to 55 Hz, 4.5 G max., 0.375-mm half amplitude for 2 h each in X, Y, and Z directions			
Reliability	Shock resistance		150 m/s ² , 3 times each in ±X, ±Y, ±Z directions			
	MTBF		135,000 hrs min.			
	Life expectancy *		10 years min.			
Construction	Dimensions (W×H×D)		Refer to <i>Dimensions</i> on page 19.			
	Weight		250 g			
	Cooling fan		No			
	Degree of protection		---			
Standards	Harmonic current emissions		Conforms to EN 61000-3-2			
	EMI *	Conducted Emissions	Conforms to EN 61204-3 Class B, EN 55011 Class B			
		Radiated Emissions	Conforms to EN 61204-3 Class B, EN 55011 Class B			
	EMS		Conforms to EN 61204-3 high severity levels			
	Safety Standards		UL 508 (Listing, excluding models with connector option) UL 60950-1, UL 62368-1 (Recognition, OVCII [≤ 3,000 m], Pol2) CSA C22.2 No.107.1 (excluding models with connector option) CSA C22.2 No.60950-1, No.62368-1 (excluding models with connector option) EN 50178 (OVCIII [≤ 2,000 m], OVCII [> 2,000 m and ≤ 3,000 m], Pol2) EN/IEC 60950-1, EN/IEC 62368-1 (OVCII [≤ 3,000 m], Pol2) Conforms to EN/IEC 61558-2-16 Conforms to PELV (EN/IEC 60204-1)			
	Marine Standards		No			
SEMI		Conforms to F47-0706 (200 VAC input)				

* Refer to *Ratings, Characteristics, and Functions* on page 11.

Item	Power rating		50 W			
	Output voltage		5 V	12 V	15 V	24 V
Efficiency *	100 VAC input		81% typ.	84% typ.	86% typ.	86% typ.
	200 VAC input		82% typ.	86% typ.	88% typ.	89% typ.
	230 VAC input		82% typ.	86% typ.	88% typ.	89% typ.
Input	Voltage range *		Single phase, 85 to 264 VAC, 80 to 370 VDC			
	Frequency *		50/60 Hz (47 to 450 Hz)			
	Current *	100 VAC input	1.1 A typ.			
		200 VAC input	0.62 A typ.			
	Power factor		---			
	Leakage current *	100 VAC input	0.5 mA max.			
		200 VAC input	1 mA max.			
Inrush current * (for a cold start at 25°C)	100 VAC input	14 A typ.				
	200 VAC input	28 A typ.				
Output	Rated Output Current		8 A	4.3 A	3.5 A	2.2A
	Voltage adjustment range *		-10% to 15% (with V.ADJ)			
	Ripple & Noise voltage *	100 to 240 VAC input	40 mVp-p max.	40 mVp-p max.	40 mVp-p max.	60 mVp-p max.
	Input variation influence *		0.5% max.			
	Load variation influence *		1.0% max.			
	Temperature variation influence	100 to 240 VAC input	0.05%/°C max.			
	Startup time *	100 VAC input	1,000 ms max.			
		200 VAC input	1,000 ms max.			
	Hold time *	100 VAC input	14 ms typ.	11 ms typ.	10 ms typ.	10 ms typ.
		200 VAC input	75 ms typ.	60 ms typ.	60 ms typ.	55 ms typ.
Additional functions	Overload protection		Yes, automatic reset			
	Overvoltage protection *		Yes, 120% or higher of rated output voltage, power shut off (shut off the input voltage and turn on the input again)			
	Overheat protection		No			
	Series operation		Yes (For up to two Power Supplies, external diodes are required.)			
	Parallel operation		No (However, backup operation is possible, external diodes are required.)			
	Remote sensing		No			
	Remote control		No			
Output indicator		Yes (LED: Green)				
Insulation	Withstand voltage		3 kVAC for 1 min. (between all input terminals and output terminals) current cutoff 20 mA 2 kVAC for 1 min. (between all input terminals and PE terminals) current cutoff 20 mA 1 kVAC for 1 min. (between all output terminals and PE terminals) current cutoff 20 mA 500 VAC for 1 min. (between all output terminals and RC terminals) current cutoff 20 mA			
	Insulation resistance		100 MΩ min. (between all output terminals and all input terminals/PE terminals) at 500 VDC			
Environment	Ambient operating temperature		-20 to 70°C (Derating is required according to the temperature.) (with no condensation or icing)			
	Storage temperature		-25 to 75°C (with no condensation or icing)			
	Ambient operating humidity		90% max. (Storage humidity: 90% max.)			
	Vibration resistance		10 to 55 Hz, 4.5 G max., 0.375-mm half amplitude for 2 h each in X, Y, and Z directions			
	Shock resistance		150 m/s ² , 3 times each in ±X, ±Y, ±Z directions			
Reliability	MTBF		135,000 hrs min.			
	Life expectancy *		10 years min.			
Construction	Dimensions (WxHxD)		Refer to <i>Dimensions</i> on page 20.			
	Weight		300 g			
	Cooling fan		No			
	Degree of protection		---			
Standards	Harmonic current emissions		Conforms to EN 61000-3-2			
	EMI *	Conducted Emissions	Conforms to EN 61204-3 Class B, EN 55011 Class B			
		Radiated Emissions	Conforms to EN 61204-3 Class B, EN 55011 Class B			
	EMS		Conforms to EN 61204-3 high severity levels			
	Safety Standards		UL 508 (Listing, excluding models with connector option) UL 60950-1, UL 62368-1 (Recognition, OVCII [≤ 3,000 m], Pol2) CSA C22.2 No.107.1 (excluding models with connector option) CSA C22.2 No.60950-1, No.62368-1 (excluding models with connector option) EN 50178 (OVCI [≤ 2,000 m], OVCI [> 2,000 m and ≤ 3,000 m], Pol2) EN/IEC 60950-1, EN/IEC 62368-1 (OVCI [≤ 3,000 m], Pol2) Conforms to EN/IEC 61558-2-16 Conforms to PELV (EN/IEC 60204-1)			
	Marine Standards		No			
SEMI		Conforms to F47-0706 (200 VAC input)				

* Refer to *Ratings, Characteristics, and Functions* on page 11.

Item	Power rating		100 W			
	Output voltage		5 V	12 V	15 V	24 V
Efficiency *	100 VAC input		79% typ.	84% typ.	85% typ.	87% typ.
	200 VAC input		81% typ.	86% typ.	87% typ.	89% typ.
	230 VAC input		81% typ.	86% typ.	87% typ.	89% typ.
Input	Voltage range *		Single phase, 85 to 264 VAC, 80 to 370 VDC			
	Frequency *		50/60 Hz (47 to 450 Hz)			
	Current *	100 VAC input	2.1 A typ.			
		200 VAC input	1.2 A typ.			
	Power factor		---			
	Leakage current *	100 VAC input	0.5 mA max.			
		200 VAC input	1 mA max.			
Inrush current * (for a cold start at 25°C)	100 VAC input	14 A typ.				
	200 VAC input	28 A typ.				
Output	Rated Output Current		16 A	8.5 A	7 A	4.5 A
	Voltage adjustment range *		-10% to 15% (with V.ADJ)			
	Ripple & Noise voltage *	100 to 240 VAC input	70 mVp-p max.	90 mVp-p max.	100 mVp-p max.	80 mVp-p max.
	Input variation influence *		0.5% max.			
	Load variation influence *		1.0% max.			
	Temperature variation influence	100 to 240 VAC input	0.05%/°C max.			
		Startup time *		1,000 ms max.		
	Hold time *	100 VAC input	12 ms typ.	11 ms typ.	11 ms typ.	10 ms typ.
		200 VAC input	70 ms typ.	55 ms typ.	55 ms typ.	55 ms typ.
	Additional functions	Overload protection		Yes, automatic reset		
Overvoltage protection *		Yes, 120% or higher of rated output voltage, power shut off (shut off the input voltage and turn on the input again)				
Overheat protection		No				
Series operation		Yes (For up to two Power Supplies, external diodes are required.)				
Parallel operation		No (However, backup operation is possible, external diodes are required.)				
Remote sensing		No				
Remote control		Yes (Only for models with remote control option)				
Insulation	Output indicator		Yes (LED: Green)			
	Withstand voltage	3 kVAC for 1 min. (between all input terminals and output terminals) current cutoff 20 mA				
		2 kVAC for 1 min. (between all input terminals and PE terminals) current cutoff 20 mA				
		1 kVAC for 1 min. (between all output terminals and PE terminals) current cutoff 20 mA				
		Only Remote control 500 VAC for 1 min. (between all output terminals and RC terminals) current cutoff 20 mA				
Insulation resistance		100 MΩ min. (between all output terminals and all input terminals/PE terminals) at 500 VDC				
Environment	Ambient operating temperature		-20 to 70°C (Derating is required according to the temperature. Refer to Engineering Data) (with no condensation or icing)			
	Storage temperature		-25 to 75°C (with no condensation or icing)			
	Ambient operating humidity		90% max. (Storage humidity: 90% max.)			
	Vibration resistance		10 to 55 Hz, 4.5 G max., 0.375-mm half amplitude for 2 h each in X, Y, and Z directions			
	Shock resistance		150 m/s ² , 3 times each in ±X, ±Y, ±Z directions			
Reliability	MTBF		135,000 hrs min.			
	Life expectancy *		10 years min.			
Construction	Dimensions (W×H×D)		Refer to <i>Dimensions</i> on page 21.			
	Weight		400 g			
	Cooling fan		No			
	Degree of protection		---			
Standards	Harmonic current emissions		Conforms to EN 61000-3-2			
	EMI *	Conducted Emissions	Conforms to EN 61204-3 Class B, EN 55011 Class B			
		Radiated Emissions	Conforms to EN 61204-3 Class B, EN 55011 Class B			
	EMS		Conforms to EN 61204-3 high severity levels			
	Safety Standards		UL 508 (Listing, excluding models with connector option or remote control option) UL 508 (Recognition, models with remote control option) UL 60950-1, UL 62368-1 (Recognition, OVCII [≤ 3,000 m], Pol2) CSA C22.2 No.107.1 (excluding models with connector option or remote control option) CSA C22.2 No.60950-1, No.62368-1 (excluding models with connector option or remote control option) EN 50178 (OVCIII [≤ 2,000 m], OVCI [> 2,000 m and ≤ 3,000 m], Pol2) EN/IEC 60950-1, EN/IEC 62368-1 (OVCI [≤ 3,000 m], Pol2) Conforms to EN/IEC 61558-2-16 Conforms to PELV (EN/IEC 60204-1)			
	Marine Standards		No			
	SEMI		Conforms to F47-0706 (200 VAC input)			

* Refer to *Ratings, Characteristics, and Functions* on page 11.

Item	Power rating		150 W				
	Output voltage		5 V	12 V	15 V	24 V	48 V
Efficiency *1	100 VAC input		78% typ.	84% typ.	85% typ.	87% typ.	85% typ.
	200 VAC input		81% typ.	87% typ.	88% typ.	89% typ.	88% typ.
	230 VAC input		81% typ.	87% typ.	88% typ.	90% typ.	88% typ.
Input	Voltage range *		Single phase, 85 to 264 VAC, 80 to 370 VDC				
	Frequency *		50 /60 Hz (47 to 450 Hz)				
	Current *	100 VAC input	3 A typ.				
		200 VAC input	1.8 A typ.				
	Power factor		---				
	Leakage current *	100 VAC input	0.5 mA max.				
		200 VAC input	1 mA max.				
Inrush current * (for a cold start at 25°C)	100 VAC input	14 A typ.					
	200 VAC input	28 A typ.					
Output	Rated Output Current		21 A	13 A	10 A	6.5 A	3.3 A
	Voltage adjustment range *		-10% to 15% (with V.ADJ)				
	Ripple & Noise voltage *	100 to 240 VAC input	100 mVp-p max.	110 mVp-p max.	80 mVp-p max.	110 mVp-p max.	120 mVp-p max.
	Input variation influence *		0.5% max.				
	Load variation influence *		1.0% max.				
	Temperature variation influence	100 to 240 VAC input	0.05%/°C max.				
		100 VAC input	1,000 ms max.				
	Startup time *	200 VAC input	1,000 ms max.				
Hold time *	100 VAC input	14 ms typ.	10 ms typ.	10 ms typ.	10 ms typ.	11 ms typ.	
	200 VAC input	80 ms typ.	55 ms typ.	55 ms typ.	55 ms typ.	55 ms typ.	
Additional functions	Overload protection		Yes, automatic reset				
	Overvoltage protection *		Yes, 120% or higher of rated output voltage, power shut off (shut off the input voltage and turn on the input again)				
	Overheat protection		No				
	Series operation		Yes (For up to two Power Supplies, external diodes are required.)				
	Parallel operation		No (However, backup operation is possible, external diodes are required.)				
	Remote sensing		No				
	Remote control		Yes (Only for models with remote control option)				
Insulation	Withstand voltage		3 kVAC for 1 min.(between all input terminals and output terminals) current cutoff 20 mA				
			2 kVAC for 1 min.(between all input terminals and PE terminals) current cutoff 20 mA				
			1 kVAC for 1 min.(between all output terminals and PE terminals) current cutoff 20 mA				
	Insulation resistance		Only Remote control 500 VAC for 1 min.(between all output terminals and RC terminals) current cutoff 20 mA 100 MΩ min.(between all output terminals and all input terminals/PE terminals) at 500 VDC				
Environment	Ambient operating temperature		-20 to 70°C (Derating is required according to the temperature. Refer to Engineering Data) (with no condensation or icing)				
	Storage temperature		-25 to 75°C (with no condensation or icing)				
	Ambient operating humidity		90% max. (Storage humidity: 90% max.)				
	Vibration resistance		10 to 55 Hz, 4.5 G max., 0.375-mm half amplitude for 2 h each in X, Y, and Z directions				
	Shock resistance		150 m/s ² , 3 times each in ±X, ±Y, ±Z directions				
Reliability	MTBF		135,000 hrs min.				
	Life expectancy *		10 years min.				
Construction	Dimensions (W×H×D)		Refer to <i>Dimensions</i> on page 23.				
	Weight		500 g				
	Cooling fan		No				
	Degree of protection		---				
Standards	Harmonic current emissions		Conforms to EN 61000-3-2 (Applicable at 80% or less of the rated load.)				
	EMI *	Conducted Emissions	Conforms to EN 61204-3 Class B, EN 55011 Class B				
		Radiated Emissions	Conforms to EN 61204-3 Class B, EN 55011 Class B				
	EMS		Conforms to EN 61204-3 high severity levels				
	Safety Standards		UL 508 (Listing, excluding models with connector option or remote control option) UL 508 (Recognition, models with remote control option) UL 60950-1, UL 62368-1 (Recognition, OVCII [≤ 3,000 m], Pol2) CSA C22.2 No.107.1 (excluding models with connector option or remote control option) CSA C22.2 No.60950-1, No.62368-1 (excluding models with connector option or remote control option) EN 50178 (OVCIII [≤ 2,000 m], OVCI [> 2,000 m and ≤ 3,000 m], Pol2) EN/IEC 60950-1, EN/IEC 62368-1 (OVCI [≤ 3,000 m], Pol2) Conforms to EN/IEC 61558-2-16 Conforms to PELV (EN/IEC 60204-1)				
	Marine Standards		No				
SEMI		Conforms to F47-0706 (200 VAC input)					

Note: Refer to *Ratings, Characteristics, and Functions* on page 11.

Item	Power rating		300 W				
	Output voltage		12 V	15 V	24 V	48 V	
Efficiency *	100 VAC input		81% typ.	81% typ.	82% typ.	82% typ.	
	200 VAC input		85% typ.	85% typ.	87% typ.	87% typ.	
	230 VAC input		85% typ.	86% typ.	87% typ.	87% typ.	
Input	Voltage range *		Single phase, 85 to 264 VAC, 120 to 370 VDC				
	Frequency *		50/60 Hz (47 to 63 Hz)				
	Current *	100 VAC input	4.2 A typ.				
		200 VAC input	2.1 A typ.				
	Power factor		0.9 min.				
	Leakage current *	100 VAC input	0.5 mA max.				
		200 VAC input	1 mA max.				
Inrush current * (for a cold start at 25°C)	100 VAC input	14 A typ.					
	200 VAC input	28 A typ.					
Output	Rated Output Current		25 A	20 A	14 A	7 A	
	Voltage adjustment range *		-10% to 15% (with V.ADJ)				
	Ripple & Noise voltage * 100 to 240 VAC input		140 mVp-p max.	270 mVp-p max.	150 mVp-p max.	330 mVp-p max.	
	Input variation influence *		0.5% max.				
	Load variation influence *		1.0% max.				
	Temperature variation influence	100 to 240 VAC input		0.05%/°C max.			
		Startup time *		1,000 ms max.			
	Hold time *	100 VAC input		30 ms typ.	30 ms typ.	30 ms typ. 40 ms typ. (Extended hold time type)	30 ms typ.
		200 VAC input		30 ms typ.	25 ms typ.	30 ms typ. 40 ms typ. (Extended hold time type)	30 ms typ.
	Additional functions	Overload protection		Yes, automatic reset			
Overvoltage protection *		Yes, 120% or higher of rated output voltage, power shut off (shut off the input voltage and turn on the input again)					
Overheat protection		Yes, power shut off (shut off the input voltage and turn on the input again)					
Series operation		Yes (For up to two Power Supplies, external diodes are required.)					
Parallel operation		No (However, backup operation is possible, external diodes are required.)					
Remote sensing		No					
Remote control		Yes (Only for models with remote control option)					
Output indicator		Yes (LED: Green)					
Insulation	Withstand voltage		3 kVAC for 1 min. (between all input terminals and output terminals) current cutoff 20 mA				
			2 kVAC for 1 min. (between all input terminals and PE terminals) current cutoff 20 mA				
			1 kVAC for 1 min. (between all output terminals and PE terminals) current cutoff 20 mA				
Insulation resistance		Only Remote control 500 VAC for 1 min. (between all output terminals and RC terminals) current cutoff 20 mA					
100 MΩ min. (between all output terminals and all input terminals/PE terminals) at 500 VDC							
Environment	Ambient operating temperature		-20 to 70°C (Derating is required according to the temperature.) (with no condensation or icing)				
	Storage temperature		-25 to 75°C (with no condensation or icing)				
	Ambient operating humidity		90% max. (Storage humidity: 90% max.)				
	Vibration resistance		10 to 55 Hz, 4.5 G max., 0.375-mm half amplitude for 2 h each in X, Y, and Z directions				
	Shock resistance		150 m/s ² , 3 times each in ±X, ±Y, ±Z directions				
Reliability	MTBF		135,000 hrs min.				
	Life expectancy *		10 years min.				
Construction	Dimensions (W×H×D)		Refer to <i>Dimensions</i> on page 25				
	Weight		700 g				
	Cooling fan		Yes				
	Degree of protection		---				
Standards	Harmonic current emissions		Conforms to EN 61000-3-2				
	EMI *	Conducted Emissions	Conforms to EN 61204-3 Class B, EN 55011 Class B				
		Radiated Emissions	Conforms to EN 61204-3 Class B, EN 55011 Class B				
	EMS		Conforms to EN 61204-3 high severity levels				
	Safety Standards		UL 508 (Listing, excluding models with remote control option) UL 508 (Recognition, models with remote control option) UL 60950-1, UL 62368-1 (Recognition, OVCII [≤ 3,000 m], Pol2) CSA C22.2 No.107.1 (excluding models with remote control option) CSA C22.2 No.60950-1, No.62368-1 (excluding models with remote control option) EN 50178 (OVCIII [≤ 2,000 m], OVCII [> 2,000 m and ≤ 3,000 m], Pol2) EN/IEC 60950-1, EN/IEC 62368-1 (OVCII [≤ 3,000 m], Pol2) Conforms to EN/IEC 61558-2-16 Conforms to PELV (EN/IEC 60204-1)				
	Marine Standards		No				
SEMI		Conforms to F47-0706 (200 VAC input)					

* Refer to *Ratings, Characteristics, and Functions* on page 11.

Item	Power rating		600 W			
	Output voltage		12 V	15 V	24 V	48 V
Efficiency *	100 VAC input		84% typ.	84% typ.	85% typ.	88% typ.
	200 VAC input		88% typ.	88% typ.	89% typ.	92% typ.
	230 VAC input		88% typ.	88% typ.	90% typ.	92% typ.
Input	Voltage range *		Single phase, 85 to 264 VAC, 120 to 350 VDC			
	Frequency *		50 /60 Hz(47 to 63 Hz)			
	Current *	100 VAC input	7.7 A typ.			
		200 VAC input	3.8 A typ.			
	Power factor		0.9 min.			
	Leakage current *	100 VAC input	0.5 mA max.			
		200 VAC input	1 mA max.			
Inrush current * (for a cold start at 25°C)	100 VAC input	14 A typ.				
	200 VAC input	28 A typ.				
Output	Rated Output Current		50 A	40 A	27 A	13 A
	Voltage adjustment range *		-10% to 15% (with V.ADJ)			
	Ripple & Noise voltage * 100 to 240 VAC input		170 mVp-p max.	170 mVp-p max.	280 mVp-p max.	340 mVp-p max.
	Input variation influence *		0.5% max.			
	Load variation influence *		1.0% max.			
	Temperature variation influence	100 to 240 VAC input	0.05%/°C max.			
		Startup time *		1,000 ms max.		
	Hold time *	100 VAC input	30 ms typ.	25 ms typ.	30 ms typ. 40 ms typ. (Extended hold time type)	30 ms typ.
		200 VAC input	30 ms typ.	25 ms typ.	30 ms typ. 40 ms typ. (Extended hold time type)	30 ms typ.
	Additional functions	Overload protection		Yes, automatic reset		
Overvoltage protection *		Yes, 120% or higher of rated output voltage, power shut off (shut off the input voltage and turn on the input again)				
Overheat protection		Yes, power shut off (shut off the input voltage and turn on the input again)				
Series operation		Yes (For up to two Power Supplies, external diodes are required.)				
Parallel operation		Yes (up to five Power Supplies, S8FS-G60024 (models with parallel operation option) only).				
Remote sensing		No				
Remote control		Yes (Only Remote control)				
Output indicator		Yes (LED: Green)				
Insulation	Withstand voltage		3 kVAC for 1 min. (between all input terminals and output terminals) current cutoff 20 mA			
			2 kVAC for 1 min. (between all input terminals and PE terminals) current cutoff 20 mA			
			1 kVAC for 1 min. (between all output terminals and PE terminals) current cutoff 20 mA			
Insulation resistance		100 MΩ min. (between all output terminals and all input terminals/PE terminals) at 500 VDC				
Environment	Ambient operating temperature		-20 to 70°C (Derating is required according to the temperature.) (with no condensation or icing)			
	Storage temperature		-25 to 75°C (with no condensation or icing)			
	Ambient operating humidity		90% max. (Storage humidity: 90% max.)			
	Vibration resistance		10 to 55 Hz, 4.5 G max., 0.375-mm half amplitude for 2 h each in X, Y, and Z directions			
	Shock resistance		150 m/s ² , 3 times each in ±X, ±Y, ±Z directions			
Reliability	MTBF		135,000 hrs min.			
	Life expectancy *		10 years min.			
Construction	Dimensions (W×H×D)		Refer to <i>Dimensions</i> on page 26.			
	Weight		1,050 g			
	Cooling fan		Yes			
	Degree of protection		---			
Standards	Harmonic current emissions		Conforms to EN 61000-3-2			
	EMI *	Conducted Emissions	Conforms to EN 61204-3 Class B, EN 55011 Class B			
		Radiated Emissions	Conforms to EN 61204-3 Class B, EN 55011 Class B			
	EMS		Conforms to EN 61204-3 high severity levels			
	Safety Standards		UL 508 (Listing, excluding models with remote control option) UL 508 (Recognition, models with remote control option) UL 60950-1, UL 62368-1 (Recognition, OVCII [≤ 3,000 m], Pol2) CSA C22.2 No.107.1 (excluding models with remote control option) CSA C22.2 No.60950-1, No.62368-1 (excluding models with remote control option) EN 50178 (OVCI [≤ 2,000 m], OVCI [> 2,000 m and ≤ 3,000 m], Pol2) EN/IEC 60950-1, EN/IEC 62368-1 (OVCI [≤ 3,000 m], Pol2) Conforms to EN/IEC 61558-2-16 Conforms to PELV (EN/IEC 60204-1)			
	Marine Standards		No			
	SEMI		Conforms to F47-0706 (200 VAC input)			

* Refer to *Ratings, Characteristics, and Functions* on page 11.

Ratings, Characteristics, and Functions

Efficiency		The value is when both rated output voltage and rated output current are satisfied.
Input	Voltage range	Do not use an inverter output for the Power Supply. Inverters with an output frequency of 50/60 Hz are available, but the rise in the internal temperature of the Power Supply may result in ignition or burning.
	Frequency	
	Current	The value is when both rated output voltage and rated output current are satisfied.
	Leakage current	The values are determined according to the Act on Power Supply Safety of Electrical Appliances and Materials.
	Inrush current (for a cold start at 25°C)	For a cold start at 25°C. Refer to the following figure.
Output	Voltage adjustment range	If the output voltage adjuster (V. ADJ) is turned, the voltage will increase by more than +15% of the voltage adjustment range. When adjusting the output voltage, confirm the actual output voltage from the Power Supply and be sure that the load is not damaged.
	Ripple & Noise voltage	The value is when both rated output voltage and rated output current are satisfied. A characteristic when the ambient operating temperature is 25°C.
	Input variation influence	This is the maximum variation in the output voltage when the input voltage is gradually changed within the allowable input voltage range at the rated output voltage and rated output current.
	Load variation influence	This is the value when the output current is changed from 0 A to the rated output current while the input voltage is within the allowable input voltage.
	Startup time	The value is when both rated output voltage and rated output current are satisfied. For a cold start at 25°C. Refer to the following figure.
	Hold time	The value is when both rated output voltage and rated output current are satisfied. At 25°C. Refer to the following figure.
Additional functions	Overvoltage protection	Refer to <i>Overvoltage Protection</i> on page 18 for the time when input voltage shuts off and input turns on again.
Reliability	Life expectancy	Refer to <i>Recommended Replacement Periods and Periodic Replacement for Preventive Maintenance</i> on page 33 for details.
Standards	EMI	Conducted Emissions
		Radiated Emissions
		The 150-W and higher models conform to Class B when an aluminum plate is set under the Power Supply.

Standard Compliance

- The input voltage range for compliance with EC Directives and other safety standards (UL, EN, etc.) is 90 to 264 VAC.
- EN/IEC 61558-2-16
To comply with EN/IEC 60204-1 (Machine Safety), a transformer is required in the control circuit. If, however, a Power Supply that has a built-in transformer that complies with EN/IEC 6155-8-2-16 is used, an external transformer is not required.
- Safety standard targets during a DC input *
During a DC input, UL 62368-1, cUR (CSA C22.2 No. 62368-1), EN/IEC 62368-1, EN 50178, EN/IEC 61558-2-16, and EN/IEC 60204-1 are safety standard targets. (However, the input voltage range is 120 to 320 VDC. The safety standards during DC input are not acquired for the S8FS-G60048□.)
It is possible to comply with the safety standards by connecting a UL-authenticated fuse. Select a UL-authenticated fuse that satisfies the following conditions:
 - S8FS-G015□□/030□□ (320 VDC or above, 3 A)
 - S8FS-G050□□ (320 VDC or above, 4 A)
 - S8FS-G100□□ (320 VDC or above, 8 A)
 - S8FS-G150□□ (320 VDC or above, 10 A)
 - S8FS-G300□□ (320 VDC or above, 12 A)
 - S8FS-G600□□ (320 VDC or above, 20 A)
- To comply with the PELV output of the EN/IEC 60204-1, ground the output negative side (-V) to PE. *

* Applicable to products produced from May 2018

Inrush Current, Startup Time, Output Hold Time

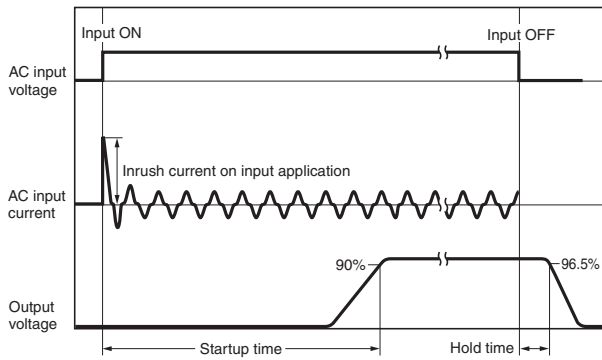

Note: The total inrush current of all of the Power Supplies will flow for parallel operation or backup operation. Sufficiently check the fusing characteristics of fuses and the operating characteristics of breakers and select fuses and breakers so that external fuses will not burn out or breakers will not operate due to inrush current.

Ripple Noise Voltage

The specified standard for the ripple voltage noise was measured with a measurement circuit that is based on JEITA standard RC-9131A.

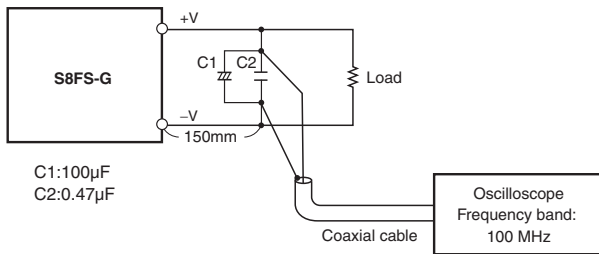

Connections

Block Diagrams

S8FS-G015□□□ (15 W)
S8FS-G030□□□ (30 W)
S8FS-G050□□□ (50 W)

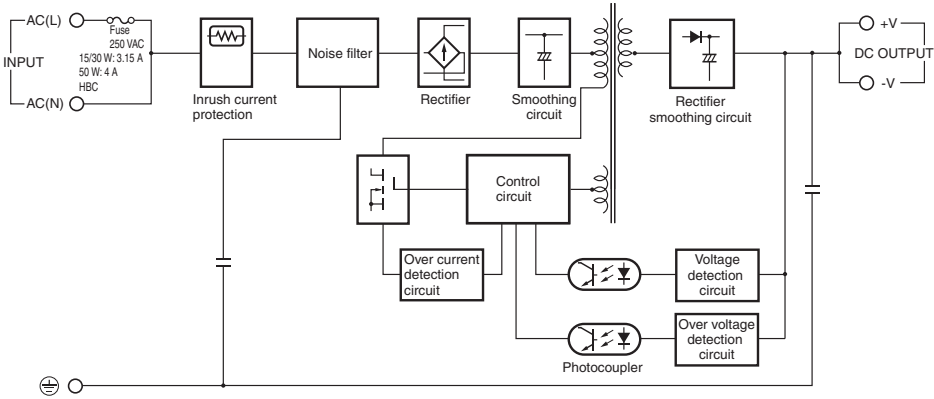

S8FS-G100□□□ (100 W)
S8FS-G150□□□ (150 W)

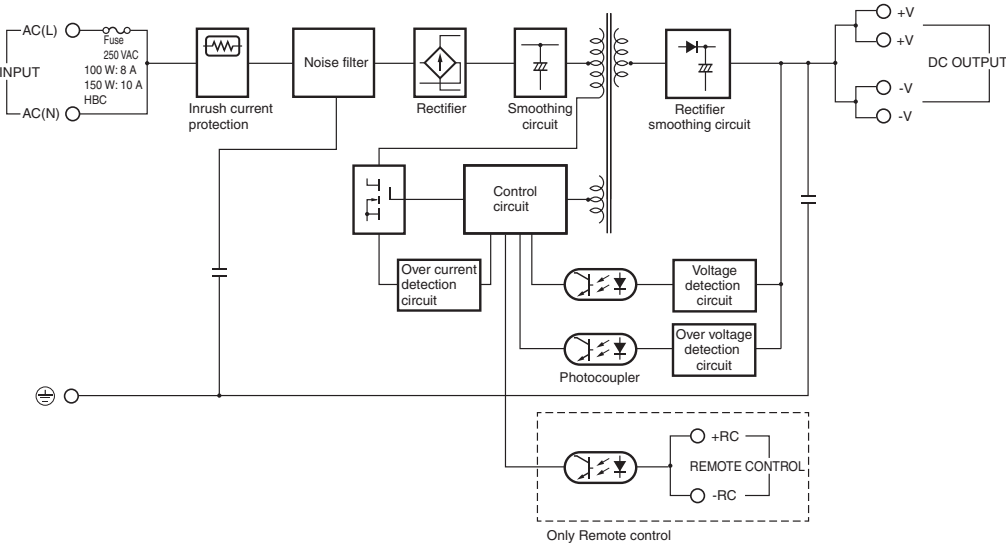

S8FS-G

S8FS-G300 (300 W)

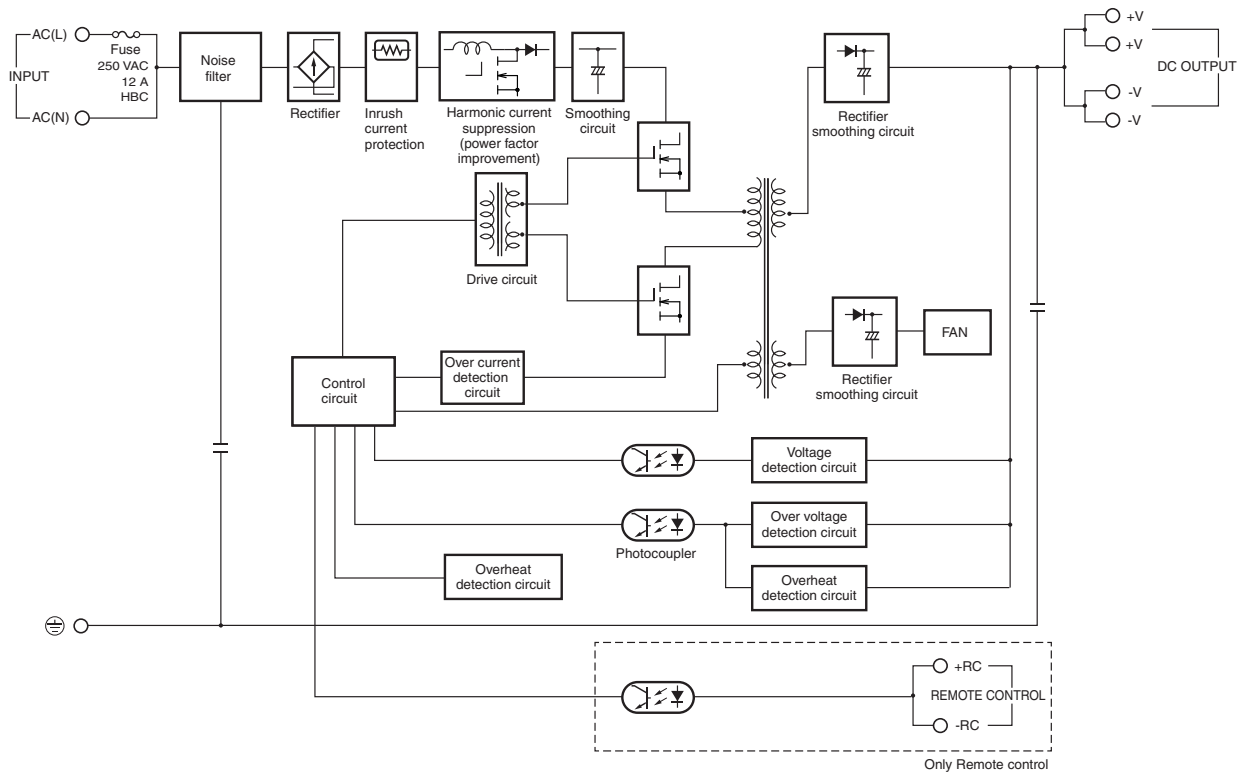

S8FS-G600 (600 W)

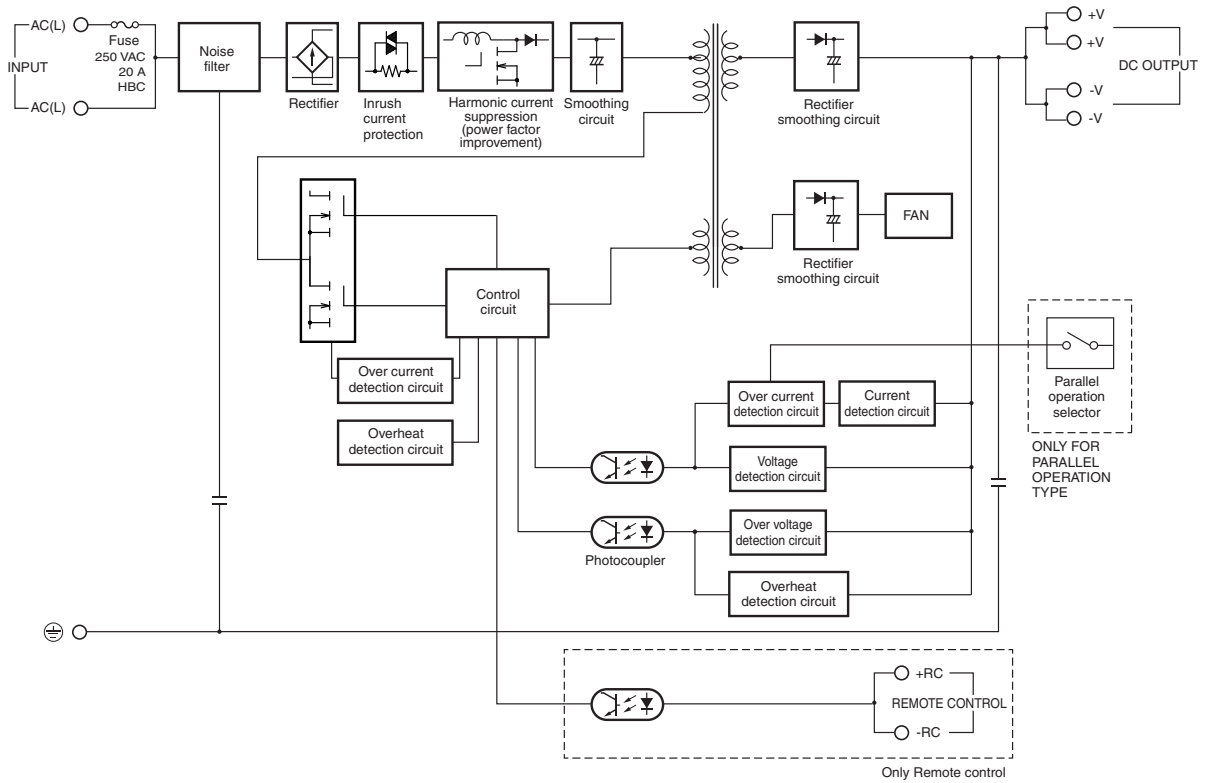

Construction and Nomenclature

Nomenclature

S8FS-G015□□□□
 S8FS-G030□□□□
 S8FS-G050□□□□

S8FS-G100□□□□
 S8FS-G150□□□□

S8FS-G300□□□□
 S8FS-G600□□□□

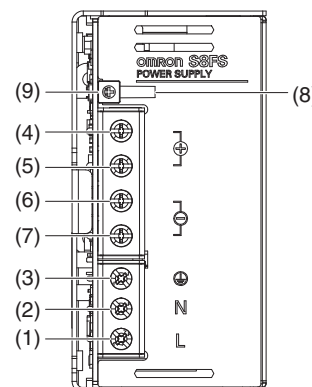
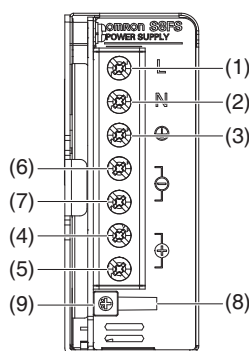
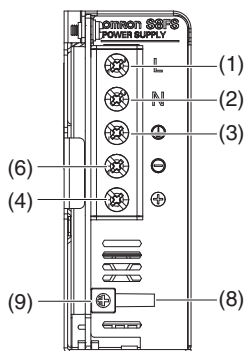

S8FS-G□□□24CE

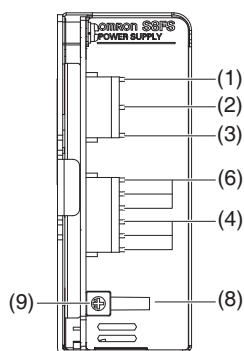

S8FS-G□□□24C-R

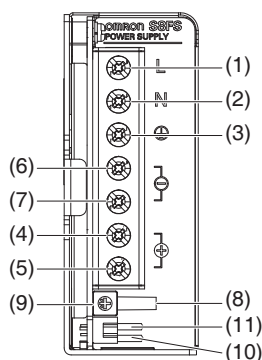

S8FS-G□□□24C-WR

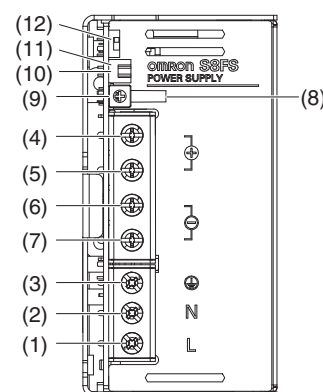

No.	Terminal name	Name	Function
(1)	L	Input terminals	Connect the input lines to these terminals. *1
(2)	N		
(3)	PE		
(4)	+V1	DC output terminals	Connect the load lines to these terminals.
(5)	+V2		
(6)	-V1		
(7)	-V2		
(8)	---	Output indicator (DC ON: green)	Lights while a direct current (DC) output is ON.
(9)	---	Output voltage adjuster (V.ADJ)	Use to adjust the voltage.
(10)	+RC	Remote control terminals	Wire for remote control.
(11)	-RC		
(12)	---	Parallel operation switch	To operate in parallel, set the switch to the "PARALLEL" side.

*1. The fuse is located on the (L) side. It is not user-replaceable. For a DC input, connect the positive voltage to the L terminal.

*2. This is the protective earth terminal specified in the safety standards. Always ground this terminal.

Input and Output Connectors (Connector type)

		Applicable connector	Housing	Terminals	Applicable crimp tool
Input side	All models	CN110	B3P5-VH (LF) (SN)	VHR-5N	YC-160R
Output side	S8FS-G01524□□E S8FS-G03024□□E S8FS-G05024□□E	CN510	B4P-VH (LF) (SN)	VHR-4N	
	S8FS-G10024□□E S8FS-G15024□□E		B6P-VH (LF) (SN)	VHR-6N	
Manufacturer		J.S.T. Mfg. Co., Ltd.			

Note: The female connectors that are required for wiring are not provided with the Power Supply.

Engineering Data

Derating Curves

Output Derating

15 W, 30 W, 50 W, 100 W, and 150 W

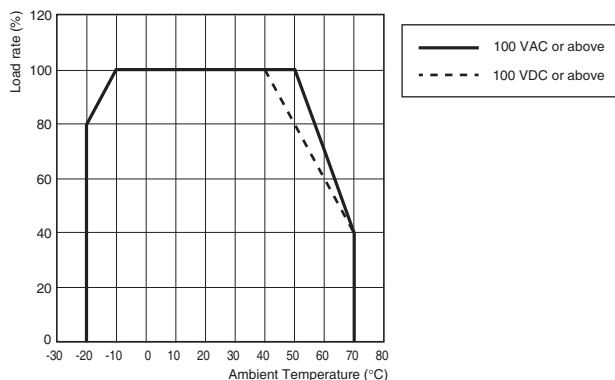

300 W and 600 W

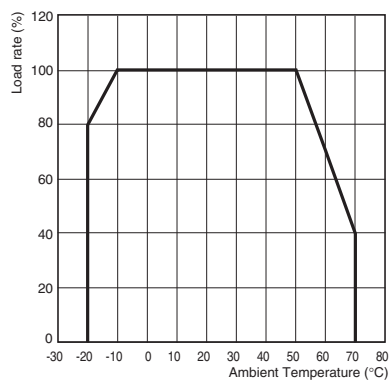

- Note: 1.** (For customers using the unit with an AC input)
At a voltage below 100 VAC, reduce the load below the range of the derating curve shown above by the solid line, at the rate of 1.3%/V.s ($40^{\circ}\text{C} < \text{Ambient temperature} \leq 70^{\circ}\text{C}$)
- 2.** (For customers using the unit with a DC input)
At a voltage below 100 VDC, reduce the load below the range of the derating curve shown above by the dashed line, by multiplying with the coefficient 0.9.

Note: At a voltage below 100 VAC, reduce the load at the rate of 1.3%/V.

Parallel Operation

For Models with Parallel Operation Option

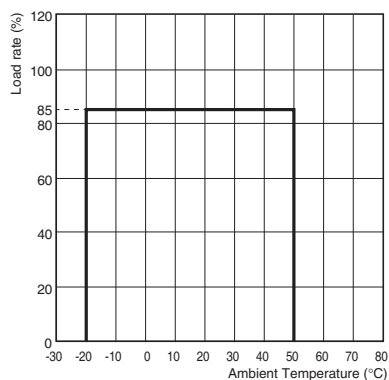

Note: At a voltage below 100 VAC, reduce the load at the rate of 1.3%/V.

This Power Supply can be used at an altitude of 3,000 m.
 Between 2,000 and 3,000 m, derate the load according to the following derating curve.

15 W to 150 W (During an AC input)

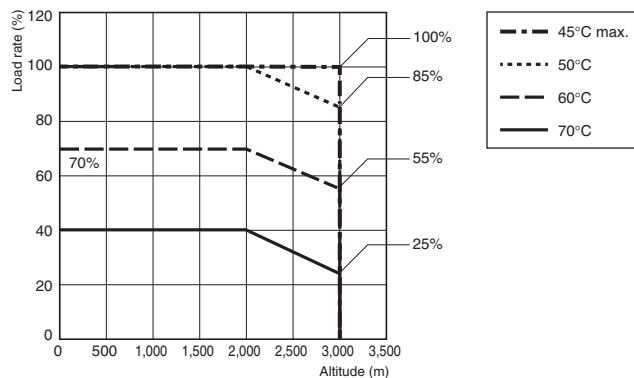

Note: At a voltage below 100 VAC, reduce the load at the rate of 1.3%/V. (40°C < Ambient temperature ≤ 70°C)

15 W to 150 W (During a DC input)

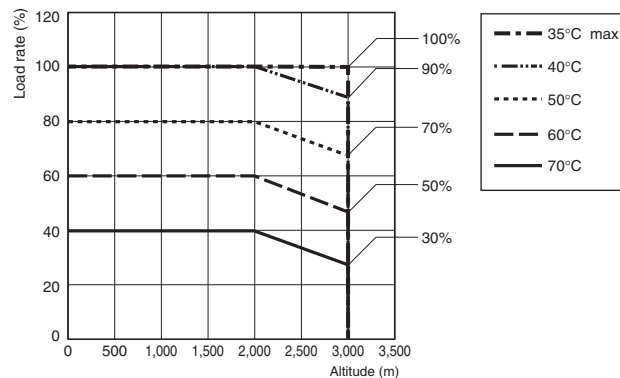

Note: At a voltage below 100 VDC, reduce the load by multiplying with the coefficient 0.9.

300 W and 600 W

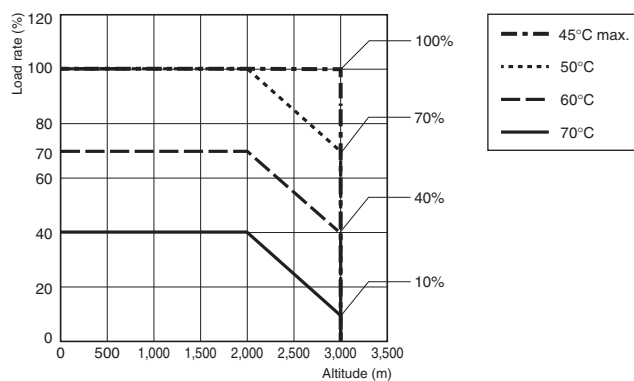

Note: At a voltage below 100 VAC, reduce the load at the rate of 1.3%/V.

Engineering Data

Overload Protection

The load and the Power Supply are automatically protected from overcurrent damage by this function. Overload protection is activated if the output current rises above 105 to 160% of the rated current. When the output current returns within the rated range overload protection is automatically cleared.

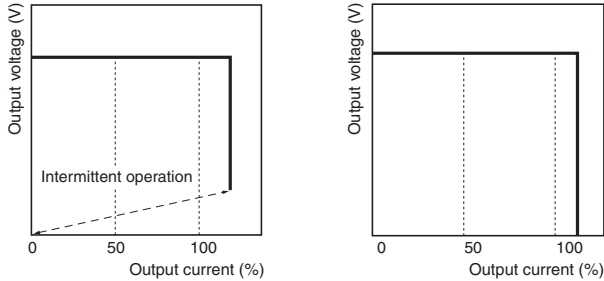

- Note: 1.** Internal parts may occasionally deteriorate or be damaged if a short-circuited or overcurrent state continues during operation.
- 2.** Internal parts may possibly deteriorate or be damaged if the Power Supply is used for applications with frequent inrush current or overloading at the load end. Do not use the Power Supply for such applications.

Overvoltage Protection

Consider the possibility of an overvoltage and design the system so that the load will not be subjected to an excessive voltage even if the feedback circuit in the Power Supply fails. If an excessive voltage that is 120% of the rated voltage or more is output, the output voltage is shut OFF. Reset the input power by turning it OFF for at least three minutes and then turning it back ON again.

Overheating Protection (300 W and 600 W)

If the internal temperature of the Power Supply rises excessively as a result of fan failure or any other reason, the overheat protection circuit will be triggered to shut OFF the output voltage. To restore operation, turn OFF the input power supply long enough for the Power Supply to cool sufficiently and then turn it ON again.

Remote Control Function (Only Remote control)

This function is to turn ON/OFF the output by applying a voltage to the remote control connector from a DC power Supply (external power supply) other than this Power Supply.

Built-in resistance Ri (Ω)	Voltage between +RC and -RC (V)		Inrush current (mA)
	Output ON	Output OFF	
780	4.5 to 12.5	0 to 0.5	20 max.

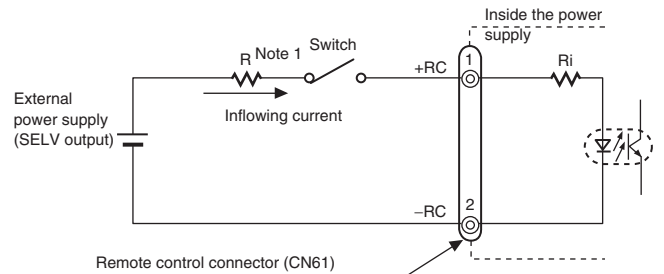

Usage example of the remote control

Connectors used:

	CN61	Applicable connector	Applicable contact
Model	B2B-XH-AM	XHP-2	SXH-001T-P0.6 or SXH-002T-P0.6
Manufacturer	J.S.T. Mfg. Co., Ltd.		

Applicable crimp tool: YC-110R (J.S.T. Mfg. Co., Ltd.) or YRS-110 (J.S.T. Mfg. Co., Ltd.)

- Note: 1.** When the external power supply is 4.5 to 12.5 V, the current limiting resistor R is not required. When it is 12.5 to 24.5 V, insert 1.5 kΩ as the current limiting resistor R.
- 2.** Reverse connection of the connector may cause damage on the internal parts.
- 3.** The +RC and -RC terminals are the secondary circuit of the Power Supply. Use an SELV output power supply for an external power supply. The remote control circuit is insulated from the secondary output of the Power Supply (functional insulation).

Reference Value

	Value
Reliability (MTBF)	Single phase model
	15W: 970,000
	30W: 970,000
	50W: 880,000
	100W: 730,000
	150W: 620,000
	300W: 200,000
	600W: 190,000
Definition	MTBF stands for Mean Time Between Failures, which is calculated according to the probability of accidental device failures, and indicates reliability of devices. Therefore, it does not necessarily represent a life of the product.
Life expectancy	10 yrs. Min.
Definition	The life expectancy indicates average operating hours under the ambient temperature of 40°C and a load rate of 50%. Normally this is determined by the life expectancy of the built-in aluminum electrolytic capacitor.

Dimensions

Power Supplies

15 W and 30 W

S8FS-G015□□C

S8FS-G030□□C

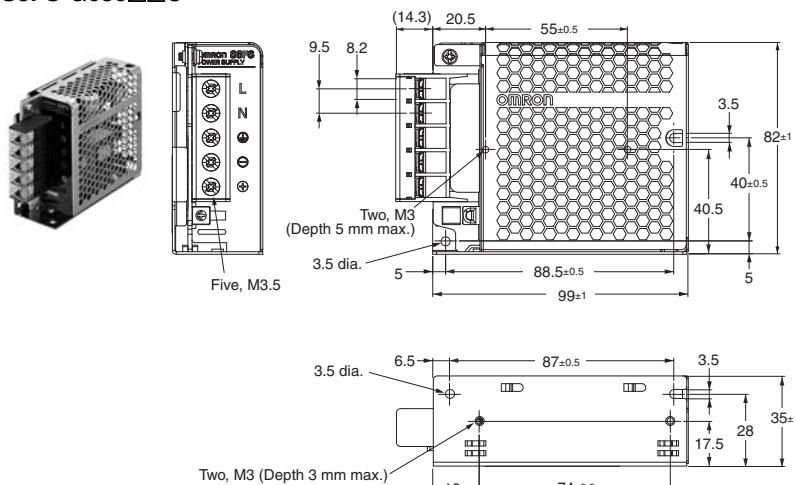

Panel mounting holes dimensions

	Using the mounting holes in the Power Supply	Using the screw holes in the Power Supply
Side Mounting	Two, M3 	Two, 3.5 dia.
Bottom Mounting	Two, M3 	Two, 3.5 dia.

S8FS-G015□□CD

S8FS-G030□□CD

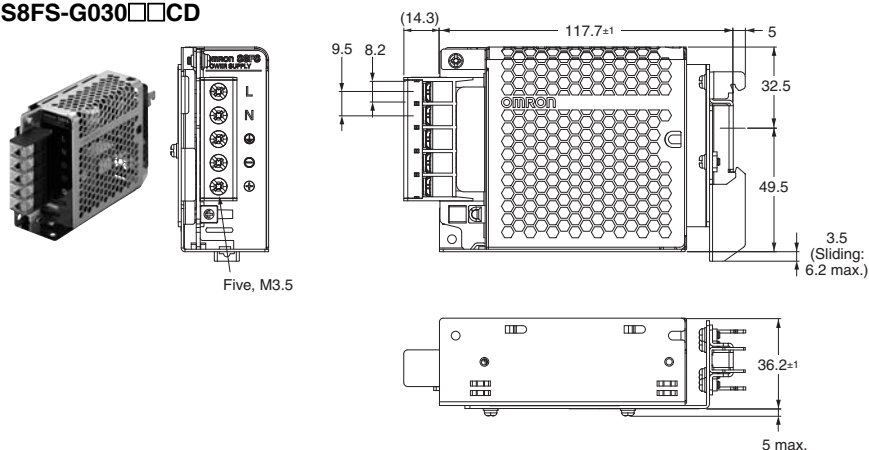

S8FS-G015□□E

S8FS-G030□□E

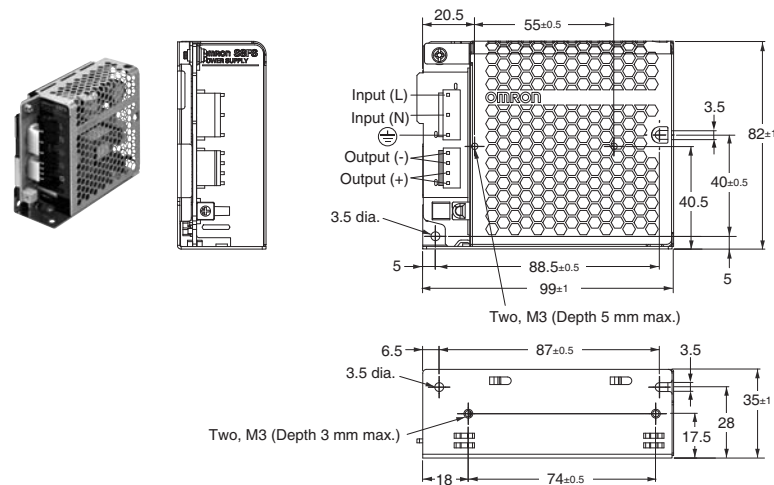

Panel mounting holes dimensions

	Using the mounting holes in the Power Supply	Using the screw holes in the Power Supply
Side Mounting	Two, M3 	Two, 3.5 dia.
Bottom Mounting	Two, M3 	Two, 3.5 dia.

S8FS-G

50W

S8FS-G050□□C

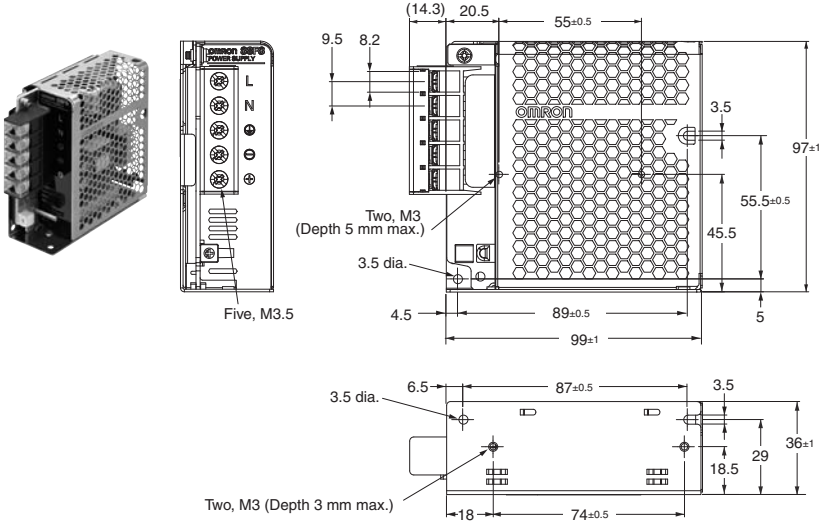

Panel mounting holes dimensions

	Using the mounting holes in the Power Supply	Using the screw holes in the Power Supply
Side Mounting	Two, M3 89±0.5 55.5±0.5	Two, 3.5 dia. 55±0.5
Bottom Mounting	Two, M3 87±0.5	Two, 3.5 dia. 74±0.5

S8FS-G050□□CD

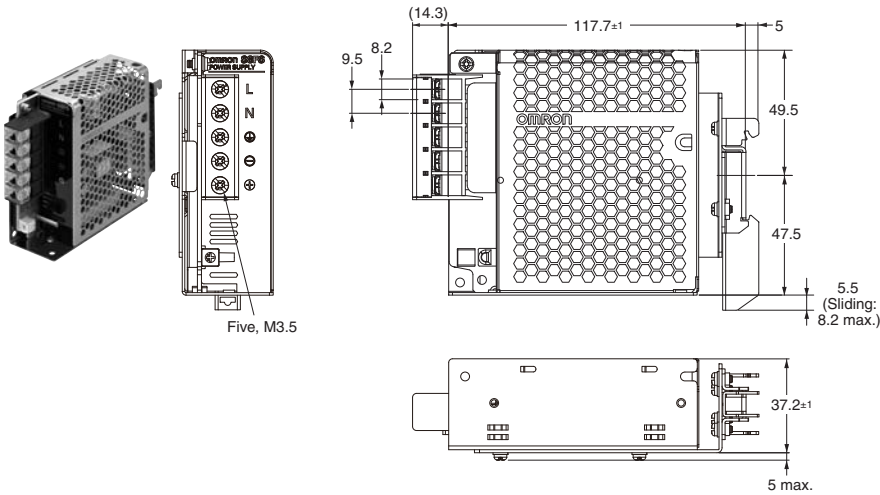

S8FS-G050□□E

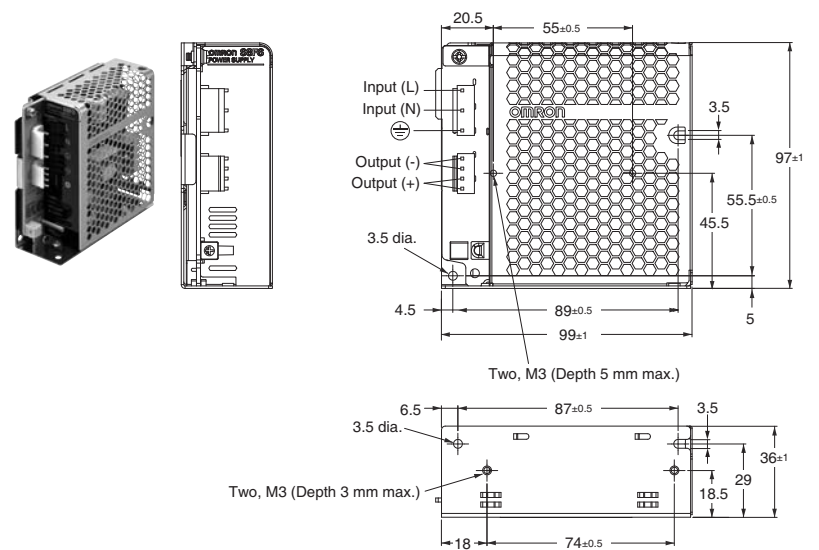

Panel mounting holes dimensions

	Using the mounting holes in the Power Supply	Using the screw holes in the Power Supply
Side Mounting	Two, M3 89±0.5 55.5±0.5	Two, 3.5 dia. 55±0.5
Bottom Mounting	Two, M3 87±0.5	Two, 3.5 dia. 74±0.5

100W

S8FS-G100□□C

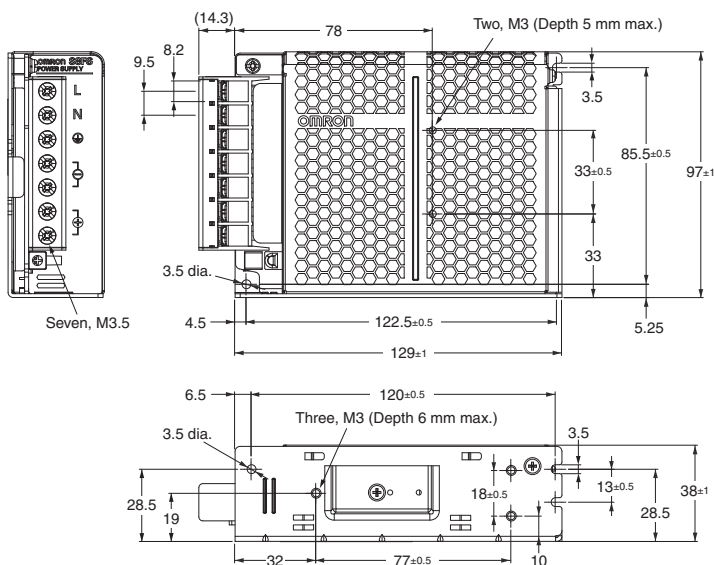

Panel mounting holes dimensions

	Using the mounting holes in the Power Supply	Using the screw holes in the Power Supply
Side Mounting		
Bottom Mounting		

S8FS-G100□□CD

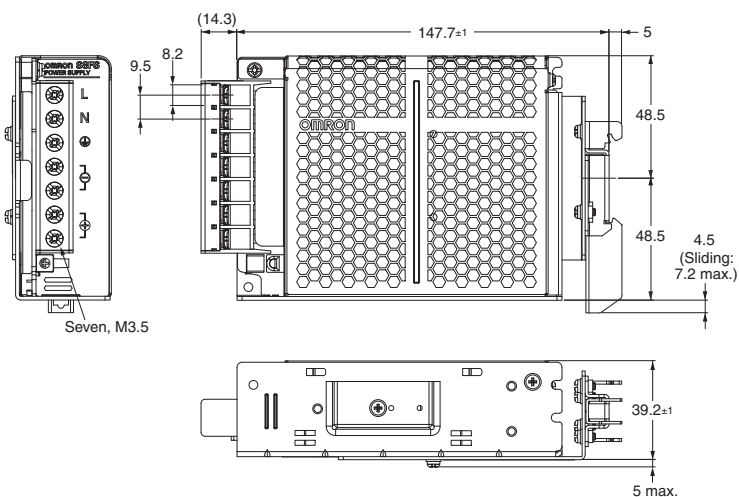

S8FS-G

S8FS-G100□□E

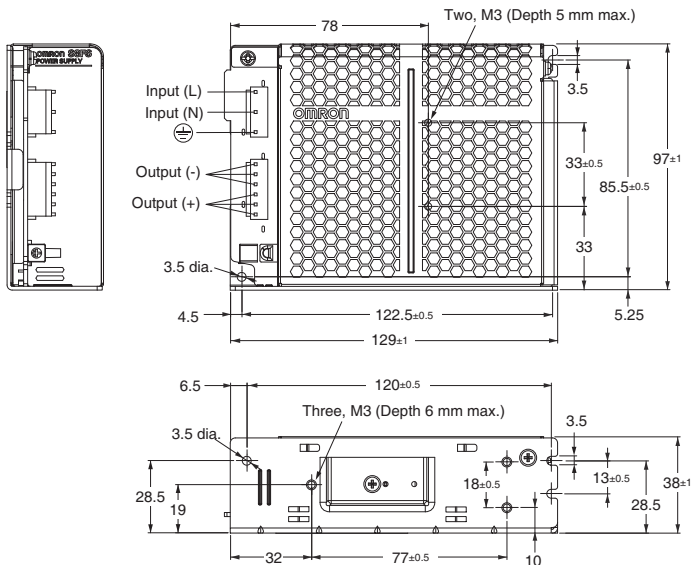

Panel mounting holes dimensions

	Using the mounting holes in the Power Supply	Using the screw holes in the Power Supply
Side Mounting	<p>Two, M3</p> <p>122.5±0.5</p> <p>85.5±0.5</p>	<p>Two, 3.5 dia.</p> <p>33±0.5</p>
Bottom Mounting	<p>Three, M3</p> <p>120±0.5</p> <p>13±0.5</p>	<p>Three, 3.5 dia.</p> <p>9±0.5</p> <p>77±0.5</p> <p>18±0.5</p>

150W

S8FS-G150□□C

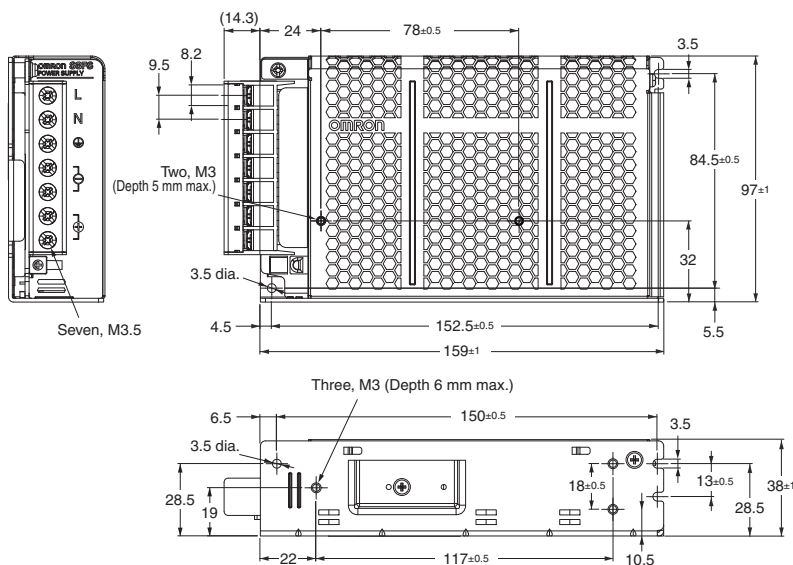

Panel mounting holes dimensions

	Using the mounting holes in the Power Supply	Using the screw holes in the Power Supply
Side Mounting		
Bottom Mounting		

S8FS-G150□□CD

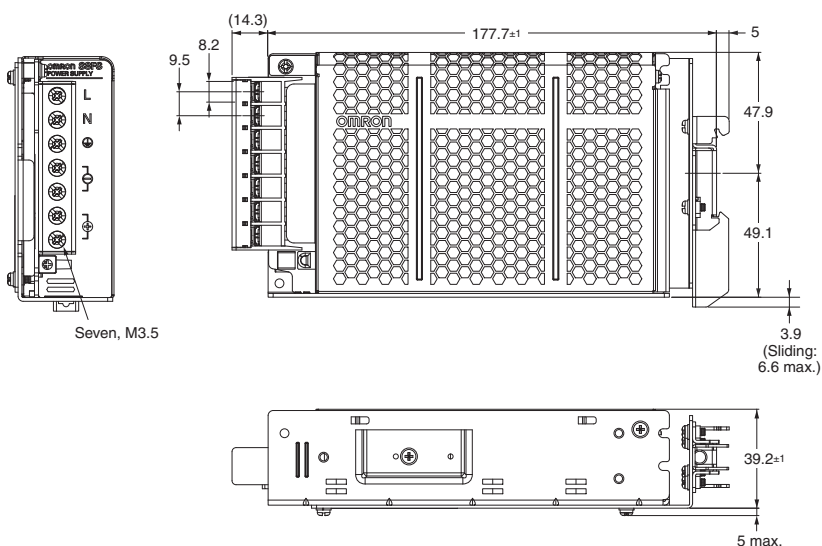

S8FS-G

S8FS-G150□□E

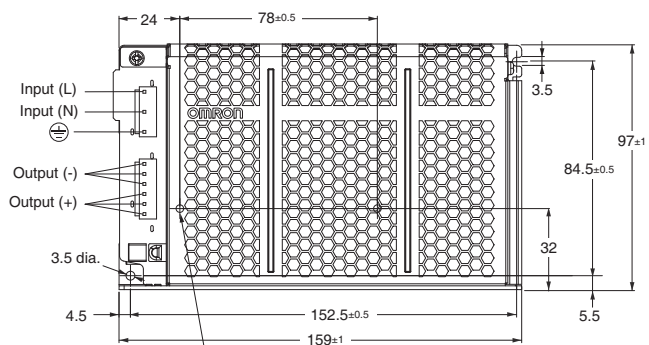
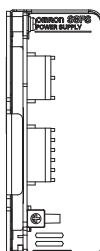

Two, M3 (Depth 5 mm max.)

Three, M3 (Depth 6 mm max.)

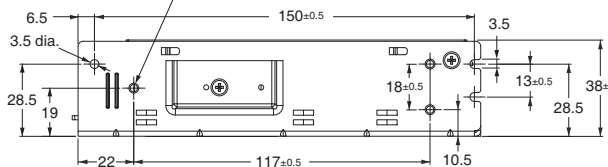

Panel mounting holes dimensions

	Using the mounting holes in the Power Supply	Using the screw holes in the Power Supply
Side Mounting	<p>Two, M3</p>	<p>Two, 3.5 dia.</p>
Bottom Mounting	<p>Three, M3</p>	<p>Three, 3.5 dia.</p>

300W

S8FS-G300□□C

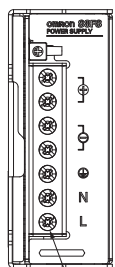

Seven, M3.5

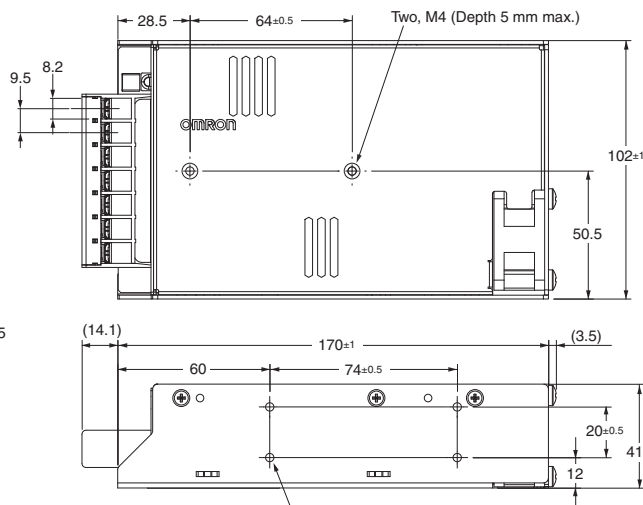

Four, M4 (Depth 5 mm max.)

Panel mounting holes dimensions

Using the screw holes in the Power Supply	
Side Mounting	Two, 4.5 dia. 64±0.5
Bottom Mounting	Four, 4.5 dia. 74±0.5 20±0.5

S8FS-G300□□CD

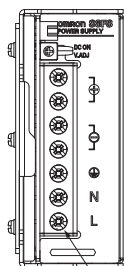

Seven, M3.5

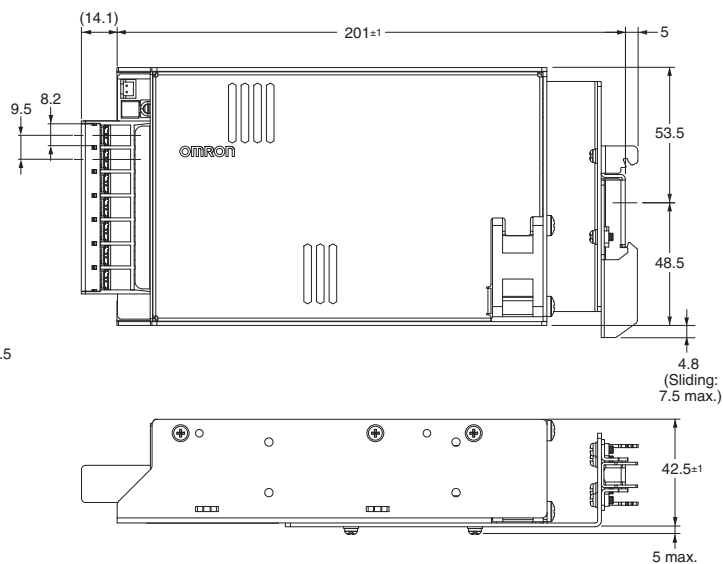

Note: Use a Front-mounting Bracket (S82Y-FSG-30F) when the DIN Rail is not strong enough for your usage environment.

S8FS-G

600W

S8FS-G600□□C

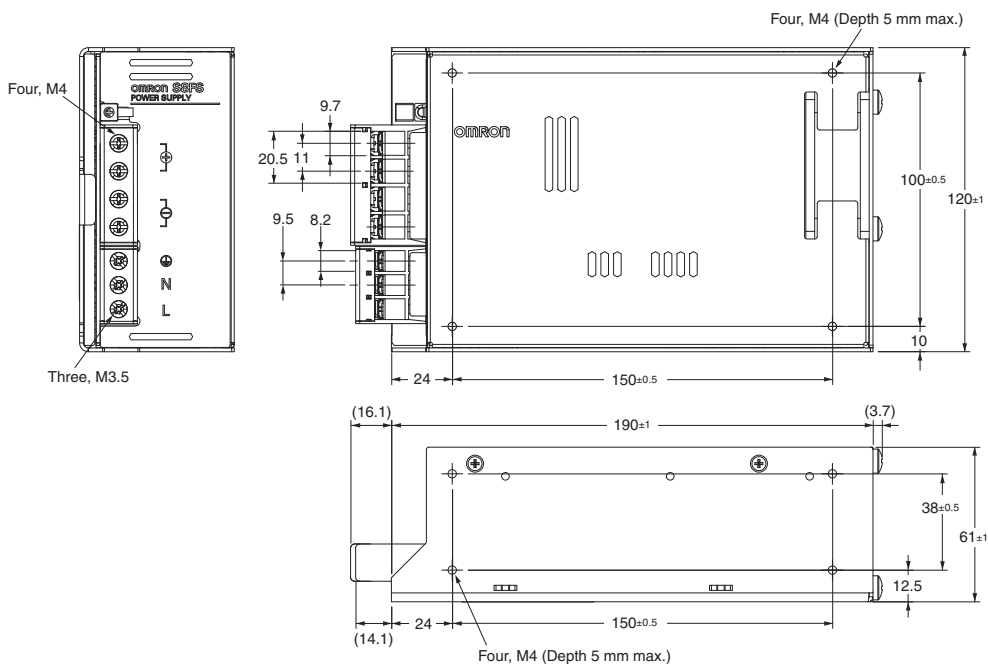

Panel mounting holes dimensions

	Using the screw holes in the Power Supply
Side Mounting	<p>Four, 4.5 dia. 150±0.5 100±0.5</p>
Bottom Mounting	<p>Four, 4.5 dia. 150±0.5 38±0.5</p>

S8FS-G600□□CD

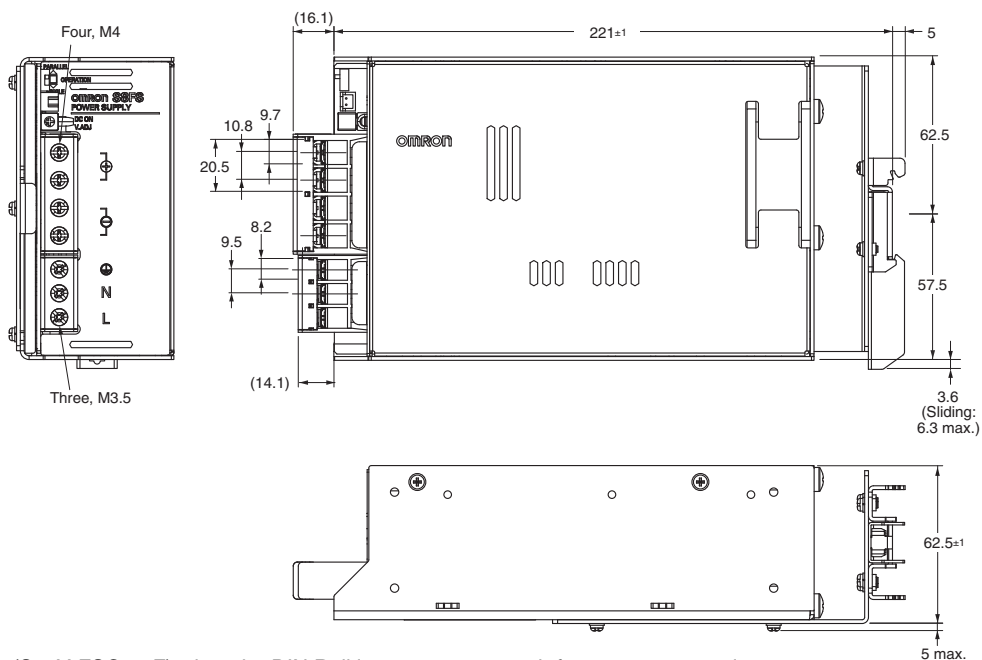

Note: Use a Front-mounting Bracket (S82Y-FSG-60F) when the DIN Rail is not strong enough for your usage environment.

Mounting Brackets (Order Separately)

Use the Front-mounting Brackets together with DIN Rail-mounting Power Supplies (S8FS-G□□□□□CD).

Power rating	Mounting direction	Model
15 W, 30 W, 50 W 100 W, 150 W and 300 W	Front-mounting	S82Y-FSG-30F
600 W	Front-mounting	S82Y-FSG-60F

S82Y-FSG-30F

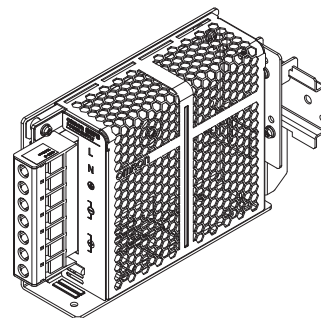
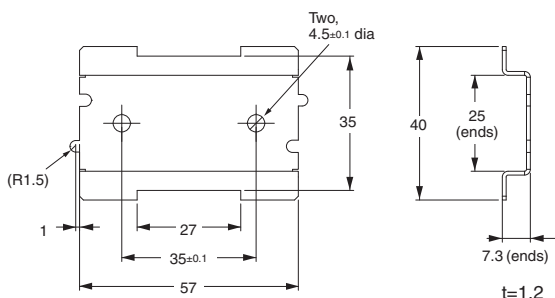

S82Y-FSG-60F

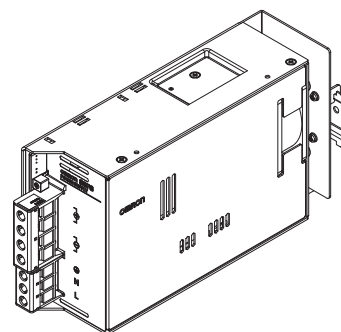
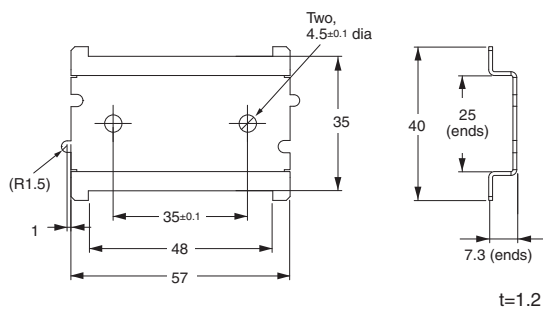

Note: Replacement brackets from the S8JX-N, S8JX-P, and S8VM series are available. Use these brackets for a front mounting configuration using direct mounting models.
Refer to the data sheet (Cat. No.: T216-E1, T217-E1, and T218-E1) for more information.

Terminal cover (Order Separately)

Power rating	Applicable models	Terminal Cover model number
15 W	S8FS-G015□□□□	S82Y-FSG-C5P
30 W	S8FS-G030□□□□	
50 W	S8FS-G050□□□□	
100 W	S8FS-G100□□□□	S82Y-FSG-C7P
150 W	S8FS-G150□□□□	
300 W	S8FS-G300□□□□	S82Y-FSG-C7P-L (Input Output)
600 W	S8FS-G600□□□□	

Note: A Terminal Block Cover is provided with the Power Supply as a standard accessory. You can purchase another one if your Cover is damaged or lost.

DIN Rail (Order Separately)

(Unit: mm)

Mounting Rail (Material: Aluminum)

PFP-100N
PFP-50N

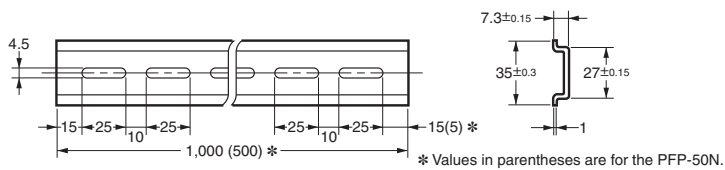
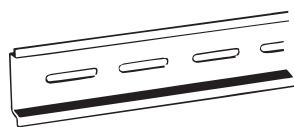

Mounting Rail (Material: Aluminum)

PFP-100N2

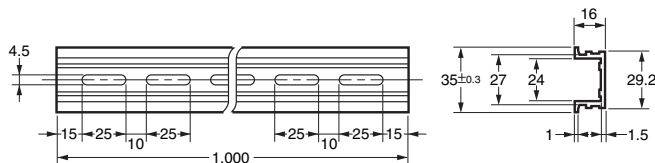
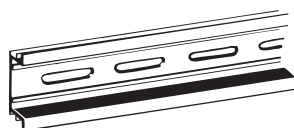

End Plate

PFP-M

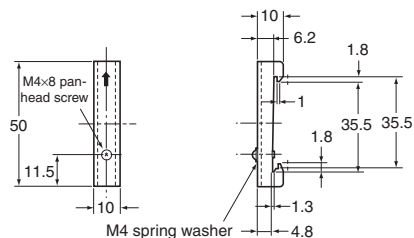

Note: If there is a possibility that the Unit will be subject to vibration or shock, use a steel DIN Rail. Otherwise, metallic filings may result from aluminum abrasion.





Safety Precautions

Refer to Safety Precautions for All Power Supplies.

Warning Indications

 CAUTION	Indicates a potentially hazardous situation which, if not avoided, may result in minor or moderate injury or in property damage.
Precautions for Safe Use	Supplementary comments on what to do or avoid doing, to use the product safely.
Precautions for Correct Use	Supplementary comments on what to do or avoid doing, to prevent failure to operate, malfunction or undesirable effect on product performance.

Meaning of Product Safety Symbols

	Used to warn of the risk of electric shock under specific conditions.
	Used to warn of the risk of minor injury caused by high temperatures.
	Use to indicate prohibition when there is a risk of minor injury from electrical shock or other source if the product is disassembled.
	Used for general mandatory action precautions for which there is no specified symbol.

CAUTION

Minor electric shock, fire, or Product failure may occasionally occur. Do not disassemble, modify, or repair the Product or touch the interior of the Product.



Minor burns may occasionally occur. Do not touch the Product while power is being supplied or immediately after power is turned OFF.



Fire may occasionally occur. Tighten terminal screws to the specified torque.

M3.5: 0.74 to 1.13N·m
M4: 1.08 to 1.32N·m



Minor injury due to electric shock may occasionally occur. Do not touch the terminals while power is being supplied.



Minor electric shock, fire, or Product failure may occasionally occur. Do not allow any pieces of metal or conductors or any clippings or cuttings resulting from installation work to enter the Product.



Precautions for Safe Use

Ambient Operating and Storage Environments

- Store the Power Supply at a temperature of -25 to 75°C and a humidity of 90% max.
- The internal parts may occasionally deteriorate or be damaged. Use the Power Supply within the derating curve.
- Use the Power Supply at a humidity of 90% max.
- Do not use locations where liquids, foreign matter, or corrosive gases may enter the interior of the Power supplies.

Installation Environment

- Do not use the Power Supply in locations subject to shocks or vibrations. In particular, install the Power Supply as far away as possible from contractors or other devices that are a vibration source.
- Install the Power Supply well away from any sources of strong, high-frequency noise and surge.

Mounting

- Take adequate measures to ensure proper heat dissipation to increase the long-term reliability of the Power Supply. Be sure to allow convection in the atmosphere around devices when mounting. Do not use in locations where the ambient temperature exceeds the range of the derating curve. The S8FS-G015□□□□ to S8FS-G150□□□□ are cooled by natural convection. Mount them so that air convection will occur around them. The S8FS-G300□□□□ and S8FS-G600□□□□ are cooled by forced airflow. Do not allow the ventilation holes to be blocked. The effectiveness of cooling would be reduced.
- When cutting out holes for mounting, make sure that cuttings do not enter the interior of the Power supplies.
- The internal parts may occasionally deteriorate and be broken due to adverse heat radiation. Do not loosen the screws on the Power Supply.
- If you mount the Power Supply with the holes provided on the chassis, do not exceed the depth given in the dimensional diagrams. Use the following tightening torques.
M3 screws: 0.48 to 0.59 N·m
M4 screws: 1.08 to 1.32 N·m

Mounting

<Standard mounting>

S8FS-G015□□□ to 150□□□

Bottom mounting

20 mm min. 20 mm min.

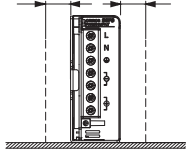

Side (horizontal orientation) mounting

20 mm min. 20 mm min.

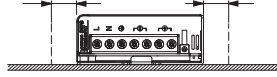

S8FS-G300□□□ and S8FS-G600□□□

Bottom mounting

20 mm min. 20 mm min.

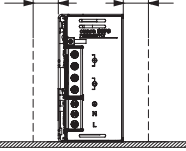

Side (horizontal orientation) mounting

20 mm min. 20 mm min.

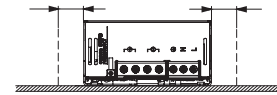

30 mm min. 30 mm min.

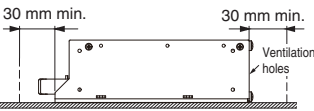
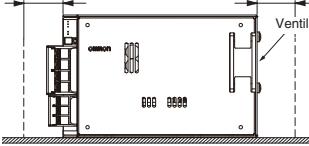

Note: Use a metal plate as the mounting surface.

DIN rail mounting

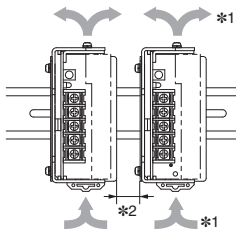

*1. Convection of air.
*2. 20 mm min.

<Other mounting types> *2

S8FS-G015□□□ to 150□□□

Side (vertical orientation) mounting

*1

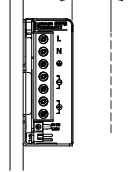

Side (upward) mounting

*1

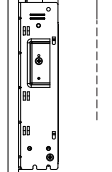

Bottom (upward) mounting

*1 *1

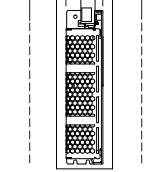

*1. 20 mm min.

*2. Applicable to products produced from May 2018

<DIN Rail Mounting>

To mount the Power Supply to a DIN Rail, hook portion (A) of the Power Supply onto the DIN Rail and press the Power Supply in direction (B) until you hear it lock into place.

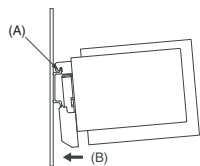

To dismount the Block, pull down portion (C) with a flat-blade screwdriver and pull out the Block.

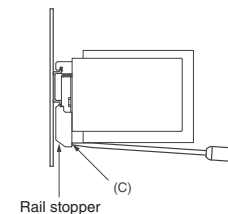

Wiring

- Connect the ground completely. A protective earthing terminal stipulated in safety standards is used. Electric shock or malfunction may occur if the ground is not connected completely.
- Minor fire may possibly occur. Ensure that input and output terminals are wired correctly.
- Do not apply more than 150-N force to the terminal block when tightening it.
- Be sure to remove the sheet covering the Power Supply for machining before power-ON so that it does not interfere with heat dissipation.
- Use the following material for the wires to be connected to the S8FS-G to prevent smoking or ignition caused by abnormal loads.

Terminals and Wiring (Screw terminal block type)

Terminals	Model	Recommendes Wire Gauges
Input	S8FS-G015□□□	AWG12-22
	S8FS-G030□□□ to 100□□□	AWG12-20
	S8FS-G150□□□ to 600□□□	AWG12-16
Output	S8FS-G01512□ to 01524□	AWG12-22
	S8FS-G03024□	AWG12-20
	S8FS-G01505□	
	S8FS-G03012□, 03015□	
	S8FS-G05015□, 05024□	
	S8FS-G15048□	AWG12-18
	S8FS-G05012□	
	S8FS-G10024□	
	S8FS-G03005□	AWG12-16
	S8FS-G10015□	
	S8FS-G15024□	
	S8FS-G30048□	
	S8FS-G05005□	AWG12-14
	S8FS-G10012□	
	S8FS-G15015□	
	S8FS-G10005□	AWG12
	S8FS-G15005□, 15012□	
S8FS-G30012□ to 30024□		
S8FS-G60015□ to 60048□	AWG10-12	
S8FS-G60012□	AWG10	
Protective earth terminal	S8FS-G015□□□ to 600□□□	AWG12-14

Note: The current capacity per output terminal is given in the following table.

S8FS-G015□□□ to S8FS-G300□□□: 20 A

S8FS-G600□□□: 30 A

Use two terminals together if the current flow is higher than the rated terminal current.

Terminals and Wiring (Connector type)

Terminals	Model	Recommendes Wire Gauges
Input	S8FS-G01524□E to 15024□E	AWG18
Output	S8FS-G01524□E to 15024□E	AWG18

- Note:**
1. The current capacity per output terminal is 5 A. Use two or more terminals together if the current flow is higher than the rated terminal current.
 2. Do not insert and remove any connector more than 20 times.
 3. Refer to Input and Output Connectors on page 15 for the model numbers of the input and output connectors.

Overcurrent Protection

- Internal parts may possibly deteriorate or be damaged if a short-circuited, overload, or boost load state continues during operation.
- Internal parts may possibly deteriorate or be damaged if the Power Supply is used for applications with frequent inrush current or overloading at the load end. Do not use the Power Supply for such applications.

Output Voltage Adjuster (V. ADJ)

- The output voltage adjuster (V. ADJ) may possibly be damaged if it is turned with unnecessary force. Do not turn the adjuster with excessive force.
- After completing output voltage adjustment, be sure that the output capacity or output current does not exceed the rated output capacity or rated output current.

Series Operation

Two Power Supplies can be connected in series operation.

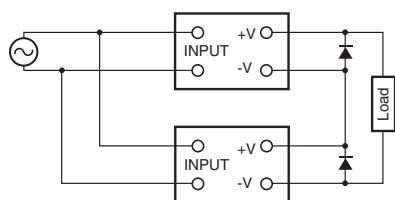

Note: 1. The diode is connected as shown in the figure. If the load is short-circuited, a reverse voltage will be generated inside the Power Supply. If this occurs the Power Supply may possibly deteriorate or be damaged. Always connect a diode as shown in the figure. Select a diode having the following ratings.

Type	Schottky Barrier diode
Dielectric strength (V_{RRM})	Twice the output voltage or above
Forward current (I_F)	Twice the rated output current or above

2. Although Power Supply having different specifications can be connected in series, the current flowing through connected in series, the current flowing through the load must not exceed the smaller rated output current.

<Making Positive/Negative Outputs>

- The outputs are floating outputs (i.e., the primary circuits and secondary circuits are separated). You can therefore make positive/negative outputs by using two Power Supplies. You can make positive/negative outputs with any of the models. If you use positive/negative outputs, connect two Power Supplies of the same model as shown below. You can combine models with different output capacities and output voltages. However, use the lower of the two rated output currents as the current to the loads.

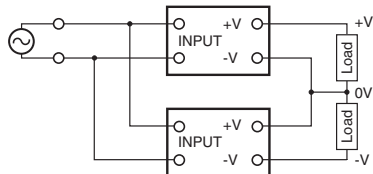

- Depending on the model, internal circuits may be damaged due to startup failure when the power is turned ON if loads such as a servomotor or operational amplifier may operate in series. Therefore, connect bypass diodes (D1, D2) as shown in the following figure. If the list of models that support series connection of outputs says that an external diode is not required, an external diode is also not required for positive/negative outputs.

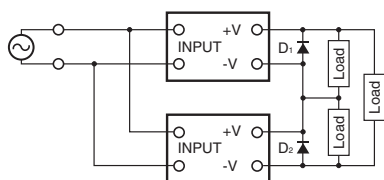

- Use the following information as a guide to the diode type, dielectric strength, and current.

Type	Schottky Barrier diode
Dielectric strength (V_{RRM})	Twice the output voltage or above
Forward current (I_F)	Twice the rated output current or above

Parallel Operation

Parallel operation is used when the output current from one Power Supply is insufficient for the load. Power Supplies are connected in parallel to increase the output current.

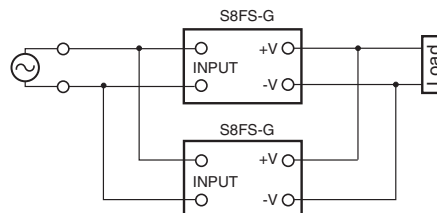

Power Supplies without the Parallel Operation Option

Parallel operation is not possible.

S8FS-G60024□-W□ (Models with the Parallel Operation Option)

Up to five Power Supplies can be connected in parallel operation. You must meet the following conditions to use parallel operation.

- The internal parts may occasionally deteriorate or be damaged. To operate in parallel, set the switch to the "PARALLEL" side.
- For parallel operation, always use Power Supplies with the same model number.
- Use the output voltage adjusters (V. ADJ) to adjust the difference in the output voltages to 50 mV or less between Power Supplies that are used in parallel operation.
- The length and thickness of each wire connected to the load must be the same so that there is no difference in the voltage drop value between the load and the output terminals of each Power Supply.
- Drastic fluctuations in the load (including fluctuations that occur when starting and starting the load) may reduce the output voltage. If fluctuations in the output voltage that result from drastic fluctuations in the load would be a problem, connect external diodes as shown in the following diagram.
- Use the following information as a guide to the diode type, dielectric strength, and current.

Type	Schottky Barrier diode
Dielectric strength (V_{RRM})	Twice the output voltage or above
Forward current (I_F)	Twice the rated output current or above

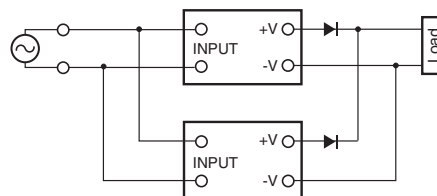

Backup Operation

Backup operation is possible if you use two Power Supplies of the same model. Even if one Power Supply fails, operation can be continued with the other Power Supply. Make sure that the maximum load does not exceed the capacity of one Power Supply. Connect the S8VK-R or external diodes as shown in the following figure for backup operation. Refer to the S8VK-R datasheet (Cat. No.: T059) for information on using the S8VK-R.

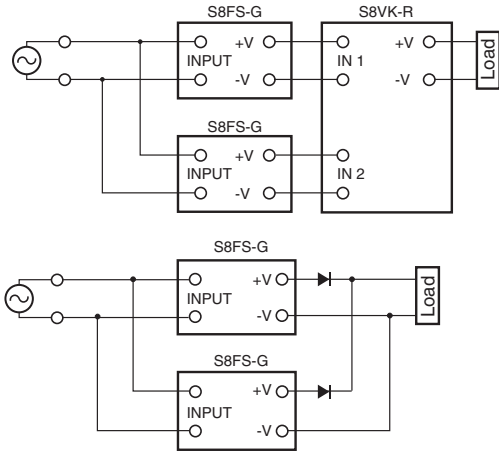

Use the following information as a guide to the diode type, dielectric strength, and current.

Type	Schottky Barrier diode
Dielectric strength (V_{RRM})	Twice the output voltage or above
Forward current (I_F)	Twice the rated output current or above

In Case There Is No Output Voltage

There is a possibility that overload protection, overvoltage protection, or overheating protection are functioning. The internal protection may operate if a large amount of surge voltage, such as a lightning inrush, is applied to the input. In addition, other possible causes for some models include stoppage of the built-in fan and the remote control function (OFF). Check the following five points. If there is still no output voltage, contact your OMRON representative.

- Checking Overload Protection:
Remove the load wires and check whether the load is in an overload state or is short-circuited.
- Checking Overvoltage or Internal Protection:
Turn the power supply OFF, leave it OFF for at least three minutes, and then turn it ON again to see if this clears the condition.
- Checking Overheating Protection (300 W/600 W):
Turn OFF the input power supply long enough for the Power Supply to cool sufficiently and then turn it ON again.
- Checking for Built-in Fan Stoppage (300 W/600 W):
Check whether or not the built-in fan has stopped.
- Confirming Remote Control Operation (Power Supplies with Remote Control):
Check whether or not the +RC and -RC terminals are open. Connect the terminals as specified.

Charging a Battery

If you connect a battery as the load, install overcurrent control and overvoltage protection circuits.

Built-in Fan Replacement

<Only S8FS-G300□□□/600□□□>
The built-in fan cannot be replaced.

Audible Noise at Power ON

<Only S8FS-G300□□□/600□□□>
A harmonic current suppression circuit is built into the Power Supply. This circuit can create noise when the input is turned ON, but it will last only until the internal circuits stabilize and does not indicate any problem in the Power Supply.

Period and Terms of Warranty

Warranty Period

The Power Supply warranty is valid for a period of five years from the date of shipment from the factory.

Terms of Warranty

The warranty is valid only for the following operating conditions.

1. Average ambient operating temperature of the Power Supply: 40°C max. (See note.)
2. Average load rate of 80% max. (See note.)
3. Mounting method: Standard mounting
4. Rated input voltage

Note: The maximum ratings must be within the derating curve.

If the Power Supply fails for reasons attributable to OMRON within the above warranty period, OMRON will repair or replace the faulty part of the Power Supply at the place of purchase or the place where the Power Supply delivered without charge.

This warranty does not cover the following types of failures.

- (1) Failures that result from handling or operation of the Power Supply under conditions or in environments that are not given in this document and not given in any other specifications exchanged between OMRON and the customer
 - (2) Failures that originate in causes other than the delivered product itself
 - (3) Failures caused by disassembly, modification, or repair of the Power Supply by anyone other than OMRON
 - (4) Failures caused by applications or uses for which the Power Supply was not originally intended
 - (5) Failures caused by factors that could not be anticipated with the scientific or technical knowledge available when the Power Supply was shipped
 - (6) Failures caused by other causes for which OMRON is not responsible, such as natural disasters and other acts of God
- This warranty is limited to the individual Power Supply that was delivered and does not cover any secondary, subsequent, or related damages.

Recommended Replacement Periods and Periodic Replacement for Preventive Maintenance

The recommended replacement period for preventive maintenance is greatly influenced by the application environment of the Power Supply. As a guideline, the recommended replacement period is 7 to 10 years.*

To prevent failures or accidents that can be caused by using a Power Supply beyond its service life, we recommend that you replace the Power Supply as early as possible within the recommended replacement period.

However, bear in mind that the recommended replacement period is for reference only and does not guarantee the life of the Power Supply.

Many electronic components are used in the Power Supply and the Power Supply depends on the correct operation of these components to achieve the original Power Supply functions and performance.

However, the influence of the ambient temperature on aluminum electrolytic capacitors is large, and the service life is reduced by half for each 10°C rise in temperature (Arrhenius law).

When the capacity reduction life of the electrolytic capacitor is reached, the Power Supply failures or accidents may occur.

We therefore recommend that you replace the Power Supply periodically to minimize product failures or accidents in advance.

* The recommended replacement period applies under the following conditions: rated input voltage, load rate of 50% max., ambient temperature of 40°C max., and the standard mounting method.

This Power Supply model is designed with a service life of 10 years minimum under the above conditions.

OMRON AUTOMATION AMERICAS HEADQUARTERS • Chicago, IL USA • 847.843.7900 • 800.556.6766 • automation.omron.com

OMRON CANADA, INC. • HEAD OFFICE

Toronto, ON, Canada • 416.286.6465 • 866.986.6766 • automation.omron.com

OMRON ELECTRONICS DE MEXICO • HEAD OFFICE

Ciudad de México • 52.55.5901.4300 • 01.800.386.6766 • mela@omron.com

OMRON ELECTRONICS DE MEXICO • SALES OFFICE

San Pedro Garza García, N.L. • 81.12.53.7392 • 01.800.386.6766 • mela@omron.com

OMRON ELECTRONICS DE MEXICO • SALES OFFICE

Eugenio Garza Sada, León, Gto • 01.800.386.6766 • mela@omron.com

OMRON ELETRÔNICA DO BRASIL LTDA • HEAD OFFICE

São Paulo, SP, Brasil • 55 11 5171-8920 • automation.omron.com

OMRON ARGENTINA • SALES OFFICE

Buenos Aires, Argentina • +54.11.4521.8630 • +54.11.4523.8483
mela@omron.com

OTHER OMRON LATIN AMERICA SALES

+54.11.4521.8630 • +54.11.4523.8483 • mela@omron.com

Authorized Distributor:

Controllers & I/O

- Machine Automation Controllers (MAC) • Motion Controllers
- Programmable Logic Controllers (PLC) • Temperature Controllers • Remote I/O

Robotics

- Industrial Robots • Mobile Robots

Operator Interfaces

- Human Machine Interface (HMI)

Motion & Drives

- Machine Automation Controllers (MAC) • Motion Controllers • Servo Systems
- Frequency Inverters

Vision, Measurement & Identification

- Vision Sensors & Systems • Measurement Sensors • Auto Identification Systems

Sensing

- Photoelectric Sensors • Fiber-Optic Sensors • Proximity Sensors
- Rotary Encoders • Ultrasonic Sensors

Safety

- Safety Light Curtains • Safety Laser Scanners • Programmable Safety Systems
- Safety Mats and Edges • Safety Door Switches • Emergency Stop Devices
- Safety Switches & Operator Controls • Safety Monitoring/Force-guided Relays

Control Components

- Power Supplies • Timers • Counters • Programmable Relays
- Digital Panel Meters • Monitoring Products

Switches & Relays



- Limit Switches • Pushbutton Switches • Electromechanical Relays
- Solid State Relays

Software



- Programming & Configuration • Runtime

Looking for pricing, stock, or lifecycle information?

Click below to explore more details on WIN SOURCE:

-  [View S8FS-G05024CD](#) on WIN SOURCE
-  [Omron](#) Information

Optimize Your Supply Chain with WIN SOURCE Solutions

-  Global Sourcing Solution
-  Obsolete Management
-  Cost Control Management
-  Shortage Management
-  Alternative Solution
-  Excess Inventory Management