



**THE DATASHEET OF  
AZ2850-2A-12DE**



# AZ2800 / AZ2850

## 40 AMP MINIATURE POWER RELAY

### FEATURES

- DPST-NO and DPDT configuration
- Meets 8 mm creepage
- 4 kV dielectric strength
- Epoxy sealed version available
- UL Class F insulation (155°C) standard
- PCB and QC terminals available
- VDE and UL/CUR approved



### CONTACTS

<b>Arrangement</b>	DPST-NO (2 Form A) DPDT (2 Form C)
<b>Ratings (max.)</b> switched power switched current switched voltage	(Resistive load) 1200 W or 11080 VA 40 A (NO), 3 A (NC) 30 VDC* or 600 VAC  * Note: If switching voltage is greater than 30 VDC, special precautions must be taken. Please contact the factory.
<b>Rated Loads</b> UL/CUR	<b>NO contacts</b> 40 A at 277 VAC, Resistive, 6k cycles [1][2] 30 A at 277 VAC, General Use, 100k cycles [1][2] 10 A at 600 VAC, General Use, 6k cycles [1] 1 HP at 120 VAC, 100k cycles [1][2] 2.5 HP at 240 VAC, 100k cycles [1][2] 8 FLA / 26 LRA at 600 VAC, 30k cycles [1] <b>NO contacts, DC coils only</b> 25.3 FLA / 110 LRA at 240VAC, 30k cycles [1][2] <b>NC contacts</b> 3 A at 277 VAC, General Use, 100k cycles [1][2] 2 A at 480 VAC, General Use, 6k cycles [1] 1 A at 600 VAC, General Use, 6k cycles [1] 3 FLA / 3 LRA at 240 VAC, 30k cycles [1] 2 FLA / 2 LRA at 480 VAC, 30k cycles [1] 1 FLA / 1 LRA at 600 VAC, 30k cycles [1]
<b>VDE</b> AZ2800 series AZ2850 series	<b>NO contacts</b> 20 A at 250 VAC, Resistive, 50k cycles [2] 30 A at 250 VAC, Resistive, 50k cycles [2] <b>NC contacts</b> 3 A at 250 VAC, Resistive, 50k cycles [2]  Notes: • Versions with 12 VAC coils are not VDE approved. • AgCdO contact versions are not VDE approved. • RT III (wash tight) versions tested at VDE with the vent hole opened.
<b>Contact materials</b>	[1] AgCdO - silver cadmium oxide [2] AgSnO <sub>2</sub> - silver tin oxide
<b>Initial resistance</b>	< 50 mΩ (24 V, 1 A - voltage drop method)

### COIL

<b>Nominal coil voltages</b>	see coil voltage specifications tables
<b>Dropout</b> DC coil types AC coil types	≥ 10% of nominal coil voltage ≥ 20% of nominal coil voltage
<b>Coil power</b> DC coil types AC coil types	typ. at 23°C (68°F) ambient temperature 1.7 W (nominal), 925 mW (at pickup) 4.0 VA (nominal) 2.6 VA (at pickup)
<b>Temperature Rise</b> DC coil types AC coil types	at nominal coil voltage 48 K (86°F) 68 K (122°F)
<b>Max. temperature</b>	155°C (311°F) - Class F

### GENERAL DATA

<b>Life Expectancy</b> mechanical electrical	(minimum operations) 5 x 10 <sup>6</sup> 1 x 10 <sup>5</sup> at 30 A, 277 VAC Resistive (NO)
<b>Operate Time</b> DC coil types	15 ms (typ.), 25 ms (max. including bounce) at nominal coil voltage
<b>Release Time</b> DC coil types	10 ms (typ.), 25 ms (max. including bounce) at nom. coil voltage, without coil suppression
<b>Dielectric Strength</b> coil to contact between open contacts between contact sets	(at sea level for 1 min.) 4000 VAC 1500 VAC 2000 VAC
<b>Surge voltage</b> coil to contact	10 kV (at 1.2 x 50 μs)
<b>Insulation Resistance</b>	1000 MΩ (min.) at 23°C, 500 VDC, 50% RH
<b>Temperature Range</b> operating DC coil types AC coil types storage	(at nominal coil voltage) -40°C (-40°F) to 85°C (185°F) -40°C (-40°F) to 65°C (149°F) -40°C (-40°F) to 105°C (221°F)
<b>Vibration resistance</b>	1.65 mm (0.065") DA at 10–55 Hz
<b>Shock</b> operational non-destructive	(11ms, 1/2 sine pulse) 10 g (no contact opening > 100μsec) 100 g
<b>Enclosure</b> type material group	P.B.T. polyester RT II (flux proof), RT III (wash tight) IIIa
<b>Terminals</b> AZ2800 series AZ2850 series	Quick connect tabs Tinned copper alloy, P. C.
<b>Soldering</b> (AZ2850 series) preheating soldering	(referring IEC 61760-1 wave soldering) 120°C (248°F) / ≤ 120 s 260 ±5°C (500 ±9°F) / ≤ 2 x 5 s
<b>Cleaning</b> (AZ2850 series) max. solvent temp. max. immersion time	(wash tight versions only) 80°C (176°F) 30 seconds
<b>Weight</b>	86 grams (approx.)
<b>Agency Approvals</b> VDE UL / CUR	40023442 E44211
<b>Packing unit in pcs</b>	20 per tray / 100 per carton box
<b>Compliance</b>	IEC 61810-1, UL508 RoHS (only for AgSnO <sub>2</sub> versions)

**ZETTLER**

# AZ2800 / AZ2850

## COIL VOLTAGE SPECIFICATIONS

### DC coils

Nominal Coil VDC	Must Operate VDC	Max. Voltage VDC	Nom. Current mA ± 10%	Resistance Ohm ± 10%
5	3.8	8.0	326.7	15.3
6	4.5	9.6	272.0	22
12	9.0	19.2	140.0	86
24	18.0	38.4	68.5	350
48	36.0	76.8	34.5	1390
110	82.5	176.0	15.2	7255

### 50Hz AC coils

Nominal Coil VAC	Must Operate VAC	Max. Voltage VAC	Nom. Current mA ± 10%	DC Res. Ohm ± 10%
12	9.6	15.6	340.0	11.25
24	19.2	26.4	166.0	45
120	96	132	33.3	1125
208	167	229	19.2	3278
220	176	242	18.2	3800
240	192	264	16.7	4500
277	222	305	14.4	5960

### 60Hz AC coils

Nominal Coil VAC	Must Operate VAC	Max. Voltage VAC	Nom. Current mA ± 10%	DC Res. Ohm ± 10%
12	9.6	15.6	340.0	9.5
24	19.2	26.4	166.0	35.7
120	96	132	33.3	830
208	167	229	19.2	2600
220	176	242	18.2	2870
240	192	264	16.7	3800
277	222	305	14.4	4700

Note: All values at 23°C (73°F), upright position, terminals downward.

## ORDERING DATA

AZ28  -   -

**Coil terminal option (AZ2800 only)**  
nil: .250 x .032 in [6.3 x 0.8 mm]  
K: .187 x .020 in [4.8 x 0.5 mm]

**Sealing option**  
nil: non sealed  
E: wash tight version

**Coil type**  
D: DC coil  
A: 60 Hz AC coil  
A5: 50 Hz AC coil

**Nominal coil voltage**  
see coil voltage specifications tables

**Contact material**  
nil: AgCdO - silver cadmium oxide (not VDE approved)  
E: AgSnO<sub>2</sub> - silver tin oxide

**Contact arrangement**  
2A: 2 Form A (DPST-NO)  
2C: 2 Form C (DPDT)

**Series**  
00: Flange mount, QC terminals  
50: PCB mount, solder terminals

### Example ordering data

AZ2800-2AE-12D Flange mount, 2 Form A, silver-tin-oxide, 12 VDC nominal coil voltage, non sealed, .250 x .032 in [6.3 x 0.8 mm] coil terminals

AZ2800-2A-120A Flange mount, 2 Form A, silver-cadmium-oxide, 120 VAC / 60 Hz nominal coil voltage, non sealed, .250 x .032 in [6.3 x 0.8 mm] coil terminals

AZ2800-2AE-240A5K Flange mount, 2 Form A, silver-tin-oxide, 240 VAC / 50 Hz nominal coil voltage, non sealed, .187 x .020 in [4.8 x 0.5 mm] coil terminals

AZ2850-2CE-24DE PCB mount, 2 Form C, silver-tin-oxide, 24 VDC nominal coil voltage, wash tight version

## INDUCTIVE LOADS LIFE REDUCTION

General curve of electrical life reduction factor at inductive AC load

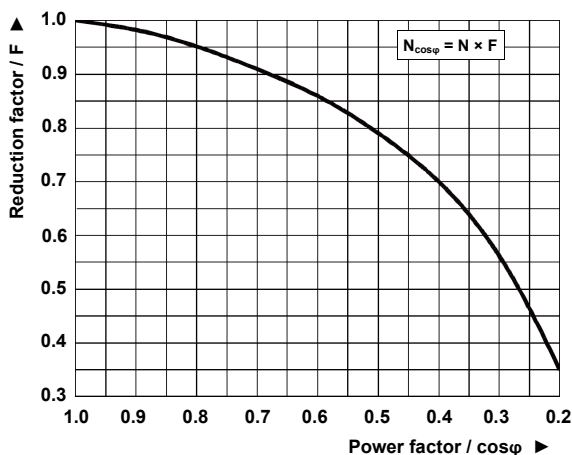

## AZ2800 MECHANICAL DATA

Dimensions in inches with metric equivalents in parentheses.  
Tolerance if not stated otherwise: ± .010"

\* Note: Only for 2 Form C (DPDT) versions

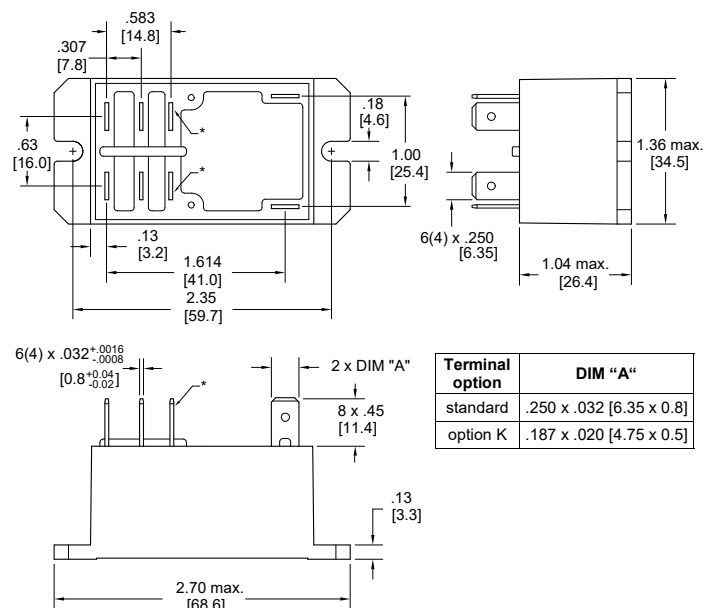

**ZETTLER**

www.ZETTLER-group.com

page 2 of 4

2023-02-14

# AZ2800 / AZ2850

## AZ2850 MECHANICAL DATA

Dimensions in inches with metric equivalents in parentheses.  
Tolerance if not stated otherwise:  $\pm .010''$

\* Note: Only for 2 Form C (DPDT) versions

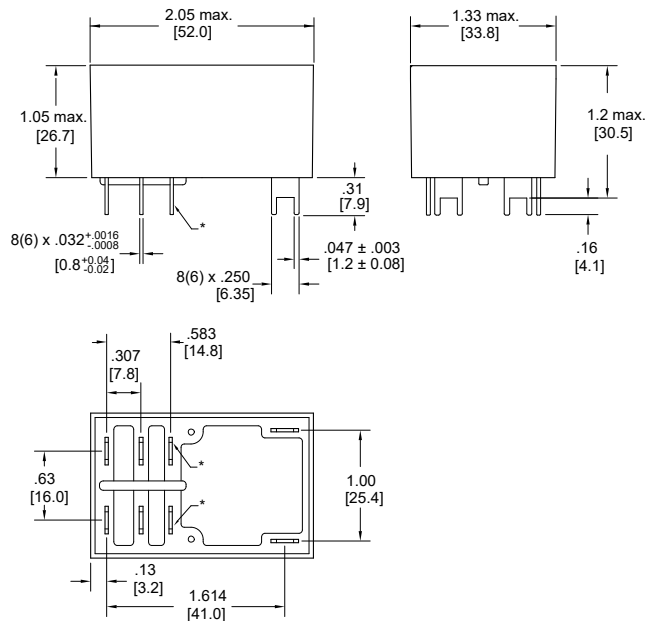

## AZ2850 PCB FOOTPRINT

Recommendation for PC board layout of AZ2850. Viewed towards terminals.  
Dimensions in inches with metric equivalents in parentheses.

\* Note: Only for 2 Form C (DPDT) versions

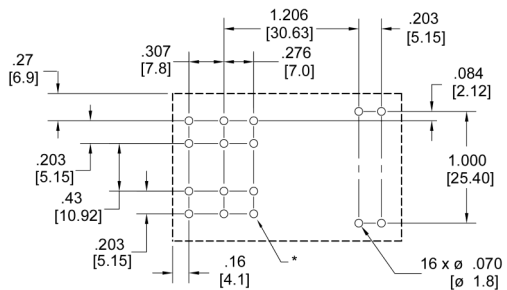

## WIRING DIAGRAMS

Viewed towards terminals

### AZ2800

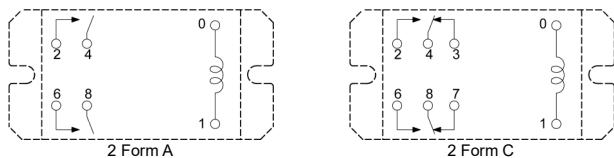

### AZ2850

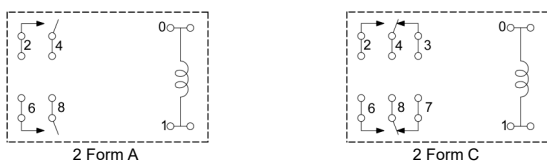

## NOTES

1. All values in this datasheet are at reference temperature of 23°C (73°F) unless stated otherwise.
2. The relay may pull in and operate with less than the specified *must operate* voltage value.
3. The coil's *must operate* voltage and the coil's *resistance* value depend on the temperature of the coil. The specified values are given for a coil temperature of 23°C and increase by approx. 0.39% per Kelvin of temperature rise.
4. Coil suppression circuits such as diodes, etc. in parallel to the coil will lengthen the release time.
5. Relays are electromechanical components that are sensitive to shock. The relay's adjustment can be affected if the relay is subjected to excessive shock or excessive pressure is applied to the relay case. Relays which have been dropped must no longer be used.
6. Substances containing silicone or phosphorus must be avoided in the vicinity to the relay. Outgassing from these substances can penetrate the relay and adhere on the contacts. Deposits of these substances may act as insulators and adversely affect the contact resistance. Silicone can be found e.g. in gaskets, lubricants or filling materials, phosphorus can be found e.g. as a flame retardant in plastics.
7. Prevent non-sealed relays from atmospheres subject to dust. Dust particles may enter the case and get stuck between the contacts, causing the contact circuits to fail.
8. Do not use these relays in environments with explosive or flammable gases. Electrical arcing at the contacts could ignite these gases and cause fire.
9. Avoid high frequency or ultrasonic vibrations on the relays as these can cause contact welding and misalignment or destruction of internal structures.
10. During operation, storage and transport, ambient temperature should be within the specified temperature range. Humidity should be in the range of 5% to 85% RH. Icing and condensation must be avoided. Relays stored for an extended period of time may show initially increased contact resistance values due to chemical effects such as oxidation.
11. For automated dual wave soldering process we recommend preheating with 120°C (248°F) for max. 120 seconds and a soldering temperature of 260  $\pm$  5°C (500  $\pm$  9°F) for max. 10 seconds soldering time (max. 5 seconds per wave). For manual soldering we recommend 350°C (662°F) max. temperature for max. 5 seconds. During the soldering process, no force may be exerted on the relay terminals.
12. Flux proof relays must not be washed, immersion cleaned or conformal coated as substances may enter the case and cause corrosion or seizure of mechanical parts.
13. For AZ2800 series flange mount types: Allow suitable slack in wiring and do not apply excessive force to the terminals. No washing or soldering allowed.
14. Versions equipped with silver cadmium oxide contacts (AgCdO) are not available within the region of the European Economic Area.
15. The datasheet and the component's specifications are subject to change without notice.

**ZETTLER**

www.ZETTLER-group.com

page 3 of 4

2023-02-14

# AZ2800 / AZ2850

## DISCLAIMER

This product specification is to be used in conjunction with the application notes which can be downloaded from the regional ZETTLER relay websites. The specification provides an overview of the most significant part features. Any individual applications and operating conditions are not taken into consideration. It is recommended to test the product under application conditions. Responsibility for the application remains with the customer. Proper operation and service life cannot be guaranteed if the part is operated outside the specified limits.

## ZETTLER GROUP

Building on a foundation of more than a century of expertise in German precision engineering, ZETTLER Group is a world-class enterprise, engaged in the design, manufacturing, sales and distribution of electronic components. Our industry leadership is based on a unique combination of engineering competence and global scale.

For more information on other ZETTLER Group companies, please visit [ZETTLER-group.com](https://www.zettler-group.com). For support on this product or other ZETTLER relays, please visit one of the group sites below.

## SITES FOR ZETTLER RELAYS

### NORTH AMERICA

American Zettler, Inc.  
[www.azettler.com](https://www.azettler.com)  
[sales@azettler.com](mailto:sales@azettler.com)

### EUROPE

Zettler Electronics, GmbH  
[www.zettlerelectronics.com](https://www.zettlerelectronics.com)  
[office@zettlerelectronics.com](mailto:office@zettlerelectronics.com)

Zettler Electronics, Poland  
[www.zettlerelectronics.pl](https://www.zettlerelectronics.pl)  
[office@zettlerelectronics.pl](mailto:office@zettlerelectronics.pl)

### CHINA

Zettler Group, China  
[www.zettlercn.com](https://www.zettlercn.com)  
[relay@zettlercn.com](mailto:relay@zettlercn.com)

### ASIA PACIFIC



Zettler Electronics (HK) Ltd.  
[www.zettlerhk.com](https://www.zettlerhk.com)  
[sales@zettlerhk.com](mailto:sales@zettlerhk.com)



**ZETTLER**

## Looking for pricing, stock, or lifecycle information?

Click below to explore more details on WIN SOURCE:

-  [View AZ2850-2A-12DE on WIN SOURCE](#)
-  [American Zettler, Inc. Information](#)

## Optimize Your Supply Chain with WIN SOURCE Solutions

-  Global Sourcing Solution
-  Obsolete Management
-  Cost Control Management
-  Shortage Management
-  Alternative Solution
-  Excess Inventory Management