



**THE DATASHEET OF
DG2753DN-T1-E4**



Low Voltage, 0.7 Ω , Triple SPDT Analog Switch

DESCRIPTION

The DG2753 is a low voltage, low on-resistance, triple single-pole/double-throw (SPDT) monolithic CMOS analog switch. The device is designed for operation from 1.65 V to 4.3 V single supply. The device is 1.8 V logic compatible within the full operation voltage range to interface with low voltage DSP or MCU control logic. These traits make it ideal for one cell Li-ion battery direct power in portable applications.

The DG2753 fully guarantees operation when V_+ is as low as 1.8 V. When powered from a 3 V power supply, it has a 0.9 Ω on-resistance, with 0.1 Ω R_{ON} matching between channels, and 0.2 Ω (Max) R_{ON} flatness.

Each switch conducts signals across power rails equally well in both directions when on, and blocks up to the power supply level when off. It offers 30 nS T_{on} and 10 nS T_{off} . Break-before-make is guaranteed.

The DG2753 is built on Vishay Siliconix's low voltage process. An epitaxial layer prevents latchup.

It is available in QFN16 3 x 3 mm and TSSOP16 packages. As a committed partner to the community and the environment, Vishay Siliconix manufactures this product with lead (Pb)-free device terminations. For analog switching products manufactured in QFN packages, the lead (Pb)-free "-E4" suffix is being used as a designator for nickel-palladium-gold. The TSSOP-16 package is offered in lead (Pb)-free with 100 % matte Tin terminations. The "-E3" suffix is the designator. Both the 100 % matte Tin and nickel-palladium gold device terminations meet all JEDEC standards for reflow and MSL ratings.

FEATURES

- Low Voltage Operation (1.65 to 4.3 V)
- Low On-Resistance - r_{ON} : 0.9 Ω at 2.7 V
- Fast Switching: T_{ON} = 30 ns
- T_{OFF} = 10 ns
- QFN-16 (3 x 3) Package
- Latch-Up Current > 300 mA (JESD78)

BENEFITS

- Reduced Power Consumption
- High Accuracy
- Reduce Board Space
- TTL/1.8 V Logic Compatible

APPLICATIONS

- Cellular Phones
- Speaker Headset Switching
- Audio and Video Signal Routing
- PCMCIA Cards
- Battery Operated Systems

FUNCTIONAL BLOCK DIAGRAM AND PIN CONFIGURATION

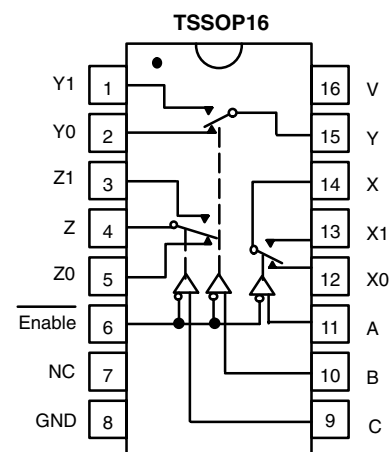
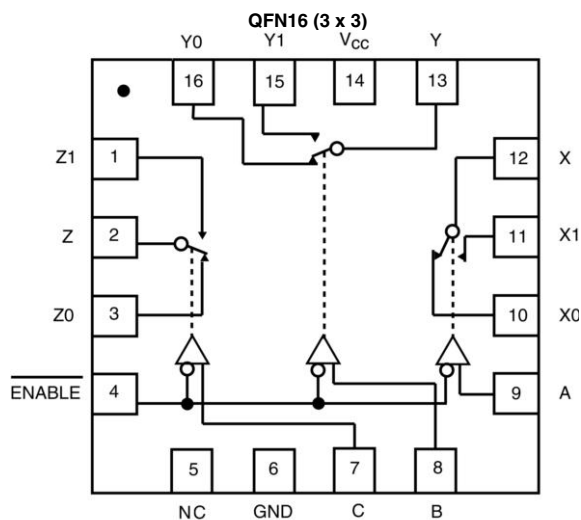

ORDERING INFORMATION

Temp Range	Package	Part Number
- 40 to 85 °C	TSSOP-16	DG2753DQ-T1-E3
	16-Pin QFN (3 mm x 3 mm) Variation 2	DG2753DN-T1-E4



TRUTH TABLE					
Enable Input	Select Inputs			ON Switches	
	C	B	A	DG2753	
H	X	X	X	All switches open	
L	X	X	L	X - X0	
L	X	X	H	X - X1	
L	X	L	X	Y - Y0	
L	X	H	X	Y - Y1	
L	L	X	X	Z - Z0	
L	H	X	X	Z - Z1	

X = Do not care

ABSOLUTE MAXIMUM RATINGS $T_A = 25\text{ }^\circ\text{C}$, unless otherwise noted			
Parameter		Limit	Unit
Reference to GND	V+	- 0.3 to 5.0	V
	IN, COM, NC, NO ^a	- 0.3 to (V+ + 0.3)	
Current (Any terminal except NO, NC or COM)		30	mA
Continuous Current (NO, NC, or COM)		± 300	
Peak Current (Pulsed at 1 ms, 10 % duty cycle)		± 500	
Storage Temperature (D Suffix)		- 65 to 150	°C
Package Solder Reflow Conditions ^d	16-Pin QFN (3 x 3 mm)	250	
Power Dissipation (Packages) ^b	QFN-16 ^c	1385	mW

Notes:

- a. Signals on NC, NO, or COM or IN exceeding V+ will be clamped by internal diodes. Limit forward diode current to maximum current ratings.
- b. All leads welded or soldered to PC Board.
- c. Derate 17.3 mW/°C above 70 °C.
- d. Manual soldering with iron is not recommended for leadless components. The QFN is a leadless package. The end of the lead terminal is exposed copper (not plated) as a result of the singulation process in manufacturing. A solder fillet at the exposed copper lip cannot be guaranteed and is not required to ensure adequate bottom side solder interconnection.

SPECIFICATIONS							
Parameter	Symbol	Test Conditions Otherwise Unless Specified V+, ± 10 %, V _{IN} = 0.4 or 1.8 V ^e	Temp ^a	Limits - 40 to 85 °C			Unit
				Min ^b	Typ ^c	Max ^b	
Analog Switch							
Analog Signal Range ^d	V _{NO} , V _{NC} , V _{COM}		Full	0		V+	V
On-Resistance	r _{DS(on)}	V+ = 2.7 V, I _{NO/NC} = 100 mA, V _{COM} = 1.7 V	Room		0.9	1.3	Ω
		V+ = 2.7 V, I _{NO/NC} = 100 mA, V _{COM} = 1.7 V	Full			1.5	
		V+ = 4.2 V, I _{NO/NC} = 100 mA, V _{COM} = 2.1 V	Room		0.7	1.2	
		V+ = 4.2 V, I _{NO/NC} = 100 mA, V _{COM} = 2.1 V	Full			1.4	
r _{ON} Match	Δr _(on)	V+ = 2.7 V, I _{NO/NC} = 100 mA, V _{COM} = 1.7 V	Room			0.4	
		V+ = 4.3 V, I _{NO/NC} = 100 mA, V _{COM} = 2.1 V	Room			0.6	
r _{ON} Resistance Flatness	r _(on) Flatness	V+ = 2.7 V, I _{NO/NC} = 100 mA, V _{COM} = 1.7 V	Room			0.2	
Switch Off Leakage Current	I _{NO(off)}	V+ = 4.3 V, V _{NO} , V _{NC} = 4 V/0.3 V, V _{COM} = 0.3 V/4 V	Room	- 2		2	nA
	I _{COM(off)}		Full	- 25		25	
Channel-On Leakage Current	I _{COM(on)}	V+ = 4.3 V, V _{COM} = V _{NO} , V _{NC} = 0.3 V/4 V	Room	- 2		2	
			Full	- 10		10	



SPECIFICATIONS								
Parameter	Symbol	Test Conditions Otherwise Unless Specified $V_{+}, \pm 10\%, V_{IN} = 0.4 \text{ or } 1.8 \text{ V}^e$	Temp ^a	Limits - 40 to 85 °C			Unit	
				Min ^b	Typ ^c	Max ^b		
Digital Control								
Input High Voltage	V_{INH}	$V_{+} = 1.8 \text{ V}$	Full	1			V	
		$V_{+} = 3 \text{ V}$	Full	1.4				
		$V_{+} = 4.3 \text{ V}$	Full	1.8				
Input Low Voltage	V_{INL}	$V_{+} = 1.8 \text{ V}$	Full			0.4		
		$V_{+} = 3 \text{ V}$	Full			0.5		
		$V_{+} = 4.3 \text{ V}$	Full			0.5		
Input Current	I_{INL}, I_{INH}	$V_{IN} = 0 \text{ V or } V_{+}$	Full	- 1		1	μA	
Dynamic Characteristics								
Turn-On Time	t_{ON}	$V_{+} = 2.7 \text{ V}$ $V_{NO}, V_{NC} = 1.5 \text{ V}, R_L = 50 \Omega, C_L = 35 \text{ pF}$	Room		30	60	ns	
Turn-Off Time	t_{OFF}		Full		10	30		
Break-Before-Make	t_{OPEN}	$V_{+} = 2.7 \text{ V}$	Full	5	30	40		
Address Transition Time	t_{TRANS}	$V_{NO}, V_{NC} = 1.5 \text{ V}, R_L = 50 \Omega, C_L = 35 \text{ pF}$	Full		40	80	pC	
Charge Injection ^d	Q_{INJ}	$V_{+} = 2.7 \text{ V}, C_L = 1 \text{ nF}, R_{GEN} = 0 \Omega, f = 500 \text{ kHz}$ $V_{NC}, V_{NO} = 2 \text{ V (test at COM side)}$	Room		- 25			
Off-Isolation ^d	O_{IRR}	$V_{+} = 2.7 \text{ V}, C_L = 1 \text{ nF}, R_{GEN} = 0 \Omega, f = 500 \text{ kHz}$ $V_{NC}, V_{NO} = 2 \text{ V (test at COM side)}$	Room		- 90			
Crosstalk ^d	X_{TALK}	$V_{+} = 2.7 \text{ V}, C_L = 1 \text{ nF}, R_{GEN} = 0 \Omega$ $V_{NC}, V_{NO} = 2 \text{ V (test at COM side)}$	Room		- 90		dB	
N_O, N_C Off Capacitance ^d	$C_{NO(off)}$	$V_{IN} = 0 \text{ or } V_{+}, f = 1 \text{ MHz}$	Room		35			
	$C_{NC(off)}$		Room		35			
Channel/On Capacitance ^d	$C_{NO(on)}$		Room		80			
	$C_{NC(on)}$		Room		80			
Power Supply								
Power Supply Current	I_{+}		$V_{IN} = 0 \text{ or } V_{+}$	Full			1	μA

Notes:

- a. Room = 25 °C, Full = as determined by the operating suffix.
- b. Typical values are for design aid only, not guaranteed nor subject to production testing.
- c. The algebraic convention where by the most negative value is a minimum and the most positive a maximum, is used in this datasheet.
- d. Guarantee by design, not subjected to production test.
- e. V_{IN} = input voltage to perform proper function.

Stresses beyond those listed under "Absolute Maximum Ratings" may cause permanent damage to the device. These are stress ratings only, and functional operation of the device at these or any other conditions beyond those indicated in the operational sections of the specifications is not implied. Exposure to absolute maximum rating conditions for extended periods may affect device reliability.

TYPICAL CHARACTERISTICS $T_A = 25\text{ }^\circ\text{C}$, unless otherwise noted

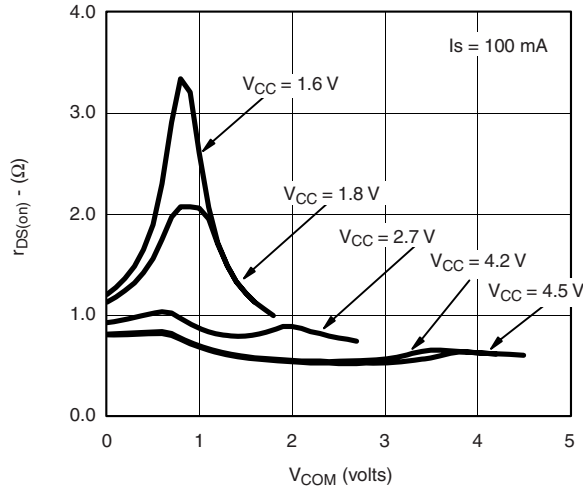

$r_{DS(on)}$ vs. V_{COM} and Supply Voltage

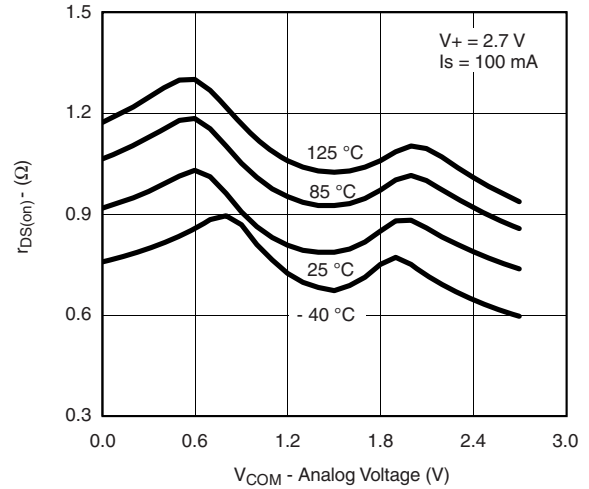

$r_{DS(on)}$ vs. Analog Voltage and Temperature

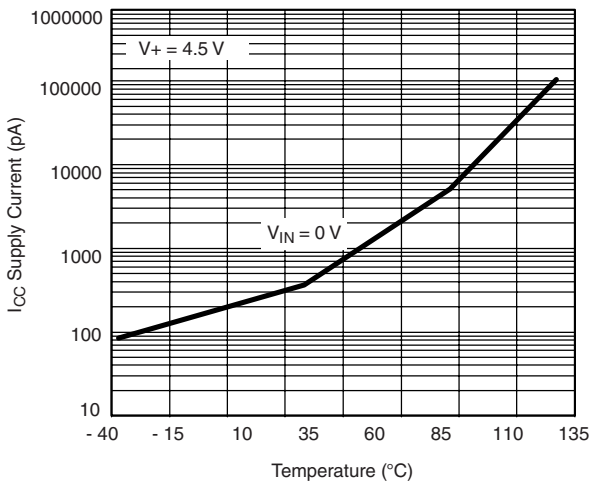

Supply Current vs. Temperature

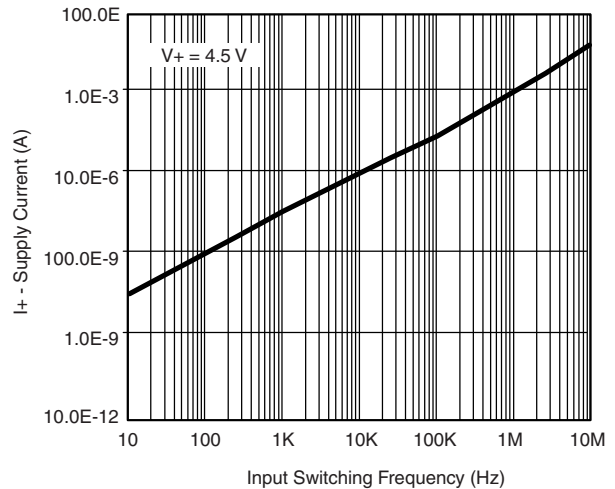

Supply Current vs. Input Switching Frequency

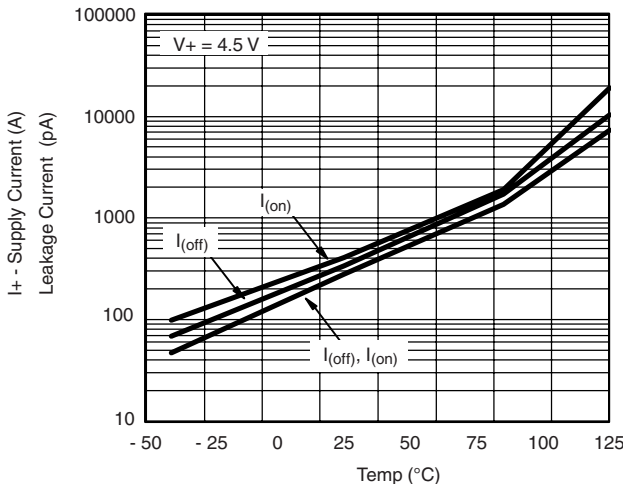

Leakage Current vs. Temperature

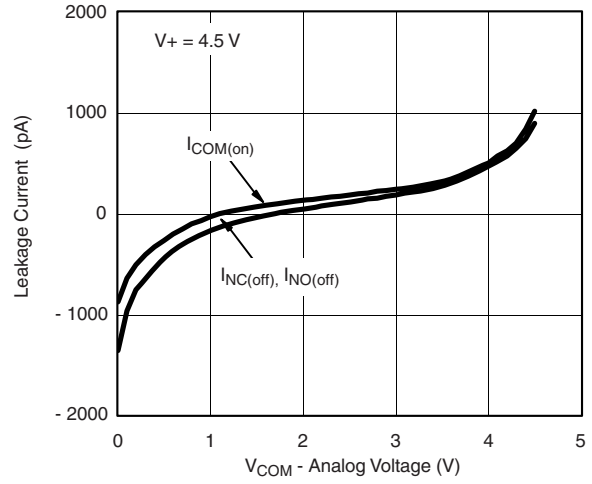

Leakage Current vs. Analog Voltage

TYPICAL CHARACTERISTICS $T_A = 25\text{ }^\circ\text{C}$, unless otherwise noted

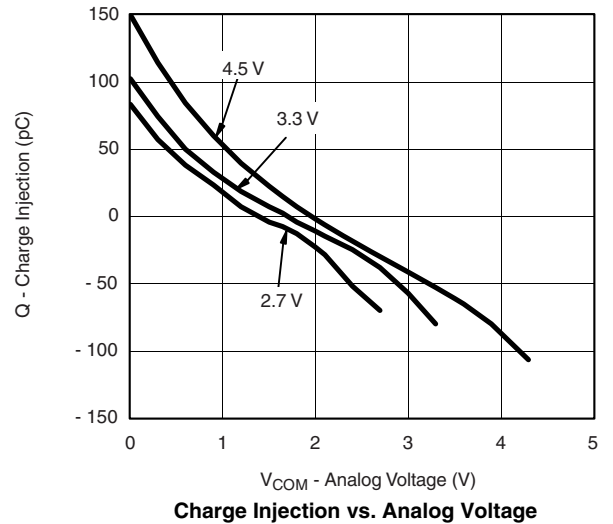
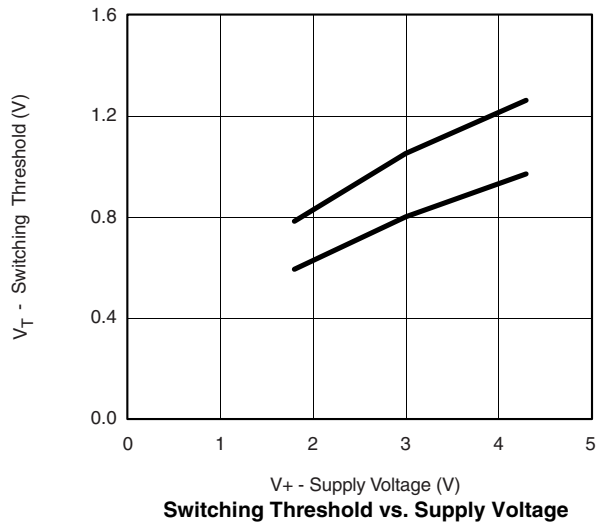
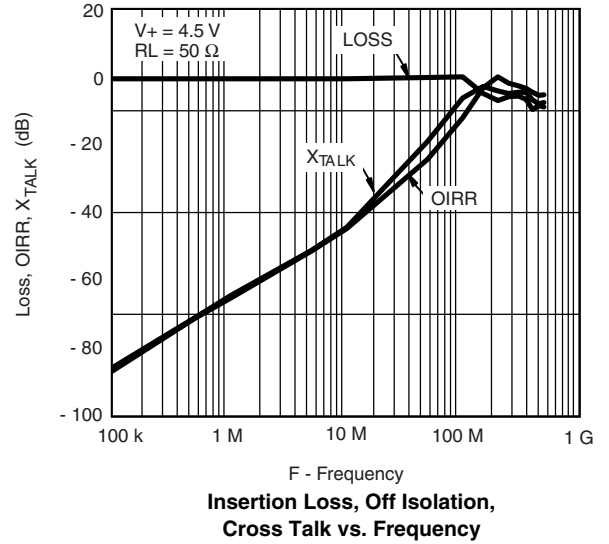
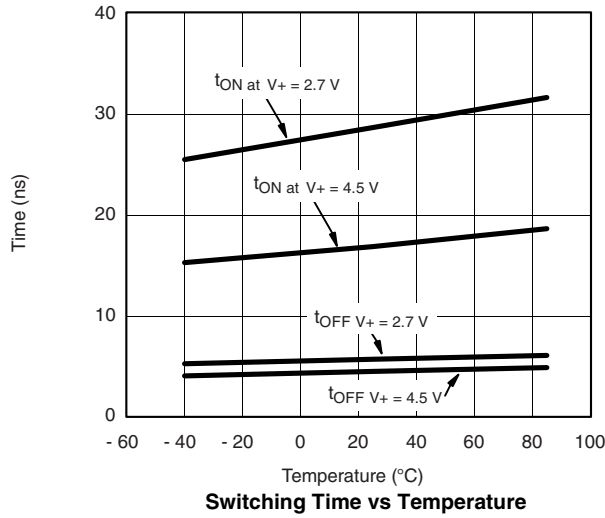

TEST CIRCUITS

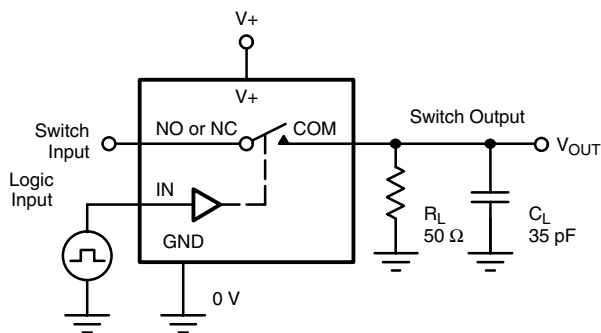

C_L (includes fixture and stray capacitance)

$$V_{OUT} = V_{COM} \left(\frac{R_L}{R_L + R_{ON}} \right)$$

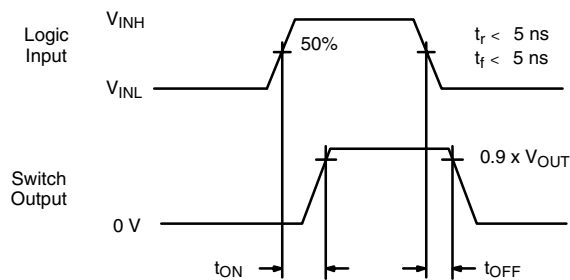

Logic "1" = Switch On
Logic input waveforms inverted for switches that have the opposite logic sense.

Figure 1. Switching Time

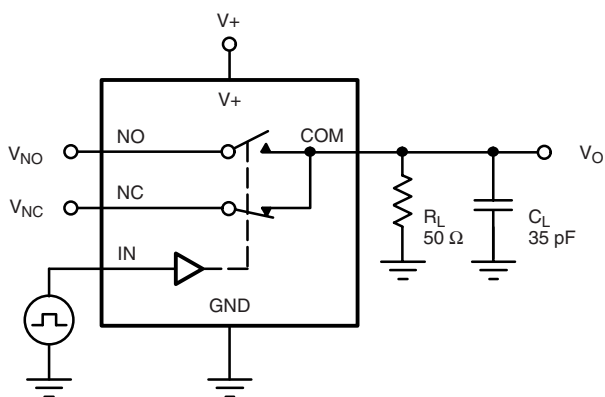

C_L (includes fixture and stray capacitance)

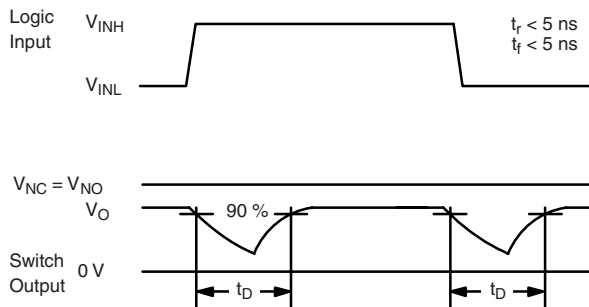
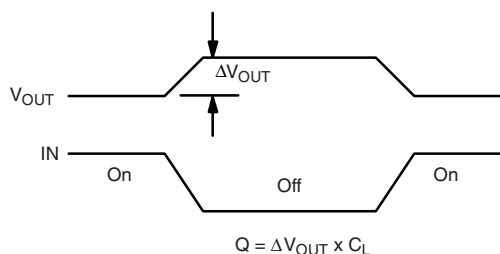
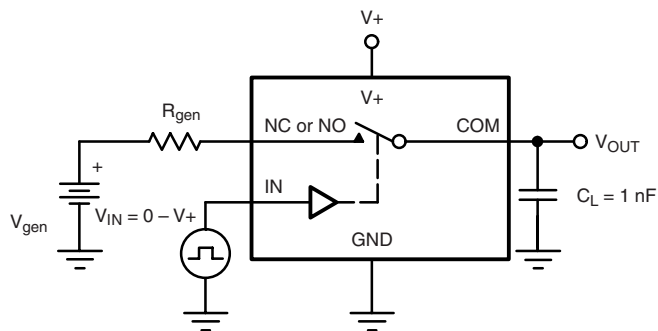

Figure 2. Break-Before-Make Interval



IN depends on switch configuration: input polarity determined by sense of switch.

Figure 3. Charge Injection

TEST CIRCUITS

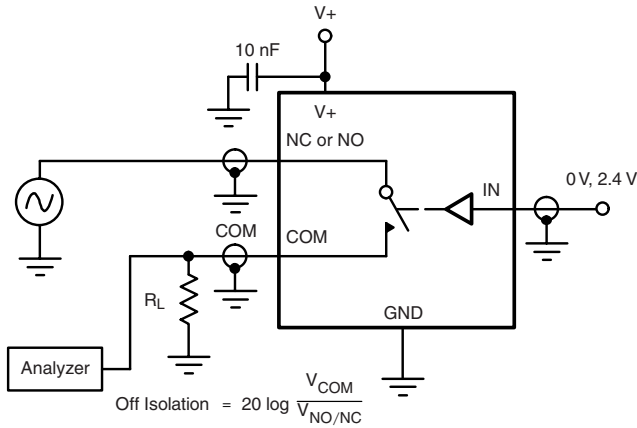

Figure 4. Off-Isolation

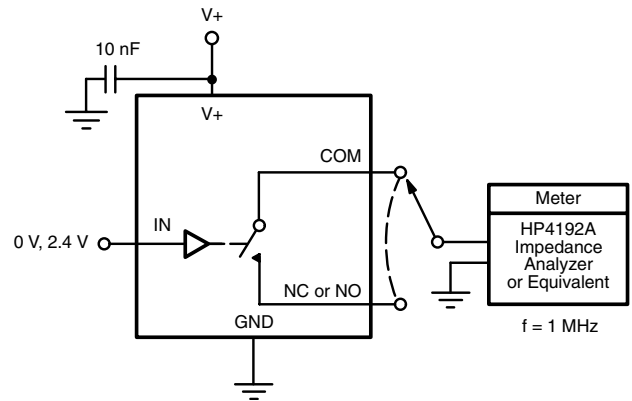

Figure 5. Channel Off/On Capacitance

Vishay Siliconix maintains worldwide manufacturing capability. Products may be manufactured at one of several qualified locations. Reliability data for Silicon Technology and Package Reliability represent a composite of all qualified locations. For related documents such as package/tape drawings, part marking, and reliability data, see <http://www.vishay.com/ppg?73482>.



Disclaimer

All product specifications and data are subject to change without notice.

Vishay Intertechnology, Inc., its affiliates, agents, and employees, and all persons acting on its or their behalf (collectively, "Vishay"), disclaim any and all liability for any errors, inaccuracies or incompleteness contained herein or in any other disclosure relating to any product.

Vishay disclaims any and all liability arising out of the use or application of any product described herein or of any information provided herein to the maximum extent permitted by law. The product specifications do not expand or otherwise modify Vishay's terms and conditions of purchase, including but not limited to the warranty expressed therein, which apply to these products.

No license, express or implied, by estoppel or otherwise, to any intellectual property rights is granted by this document or by any conduct of Vishay.

The products shown herein are not designed for use in medical, life-saving, or life-sustaining applications unless otherwise expressly indicated. Customers using or selling Vishay products not expressly indicated for use in such applications do so entirely at their own risk and agree to fully indemnify Vishay for any damages arising or resulting from such use or sale. Please contact authorized Vishay personnel to obtain written terms and conditions regarding products designed for such applications.

Product names and markings noted herein may be trademarks of their respective owners.

Looking for pricing, stock, or lifecycle information?

Click below to explore more details on WIN SOURCE:

 [View DG2753DN-T1-E4 on WIN SOURCE](#)

 [Vishay Information](#)

Optimize Your Supply Chain with WIN SOURCE Solutions

-  Global Sourcing Solution
-  Obsolete Management
-  Cost Control Management
-  Shortage Management
-  Alternative Solution
-  Excess Inventory Management