



**THE DATASHEET OF
AZ733W-2AE-12DE**



AZ733W

DPST MINIATURE POWER RELAY

FEATURES

- Dielectric strength 5000 VAC
- 1.5 mm contact gap
- Epoxy sealed version available
- Gold plated versions available
- 12 Amp switching
- Double pole contacts
- Isolation spacing greater than 8 mm
- UL, CUR file E44211
- TÜV certificate R50129285



Illustration similar

CONTACTS

Arrangement	DPST (2 Form A)
Ratings (max.) switched power switched current switched voltage	(resistive load) 360 W or 3324 VA 12 A 250 VDC* or 400 VAC * Note: If switching voltage is greater than 30 VDC, special precautions must be taken. Please contact the factory.
Rated Loads UL/CUR	12 A at 277 VAC resistive, 85°C, 100k cycles [1][2] 10 A at 277 VAC cos ϕ 0.6, 40°C, 30k cycles [2] 12 A at 30 VDC resistive, 85°C, 10k cycles [1][2] 1/2 HP at 125 VAC, 40°C, 100k cycles [2] 1/3 HP at 125 VAC, 40°C, 1k cycles [1] 3/4 HP at 250 VAC, 40°C, 1k cycles [1] 3/4 HP at 250 VAC, 40°C, 100k cycles [2] TV5 at 125 VAC, 40°C, 25k cycles [2]
TÜV	12 A at 250 VAC resistive, 70°C, 10k cycles [1][2] 10 A at 250 VAC resistive, 70°C, 30k cycles [1][2]
Contact materials	AgNi (silver nickel) [1] AgSnO ₂ (silver tin oxide) [2] gold plating available
Contact gap	≥ 1.5 mm
Initial resistance max. typ.	(1A / 24V, voltage drop method) 50 mΩ < 5 mΩ

COIL

Nominal coil DC voltages	see coil voltage specifications table
Operative range	class 1 (80% to 110% of rated voltage)
Dropout voltage	> 10% of nominal coil voltage
Coil power at nominal voltage at pickup voltage	(typ. at 23°C) 800 mW 450 mW
Temperature Rise	typ. 40 K (72°F) at nominal coil voltage
Max. temperature	155°C (311°F), class F

GENERAL DATA

Life Expectancy mechanical electrical	(minimum operations) 5 x 10 ⁵ 1 x 10 ⁵ at 10 A 250 VAC resistive
Operate Time max. / typ.	(at nominal coil voltage) 15 ms / < 10 ms
Release Time max. / typ.	(at nom. coil voltage, without coil suppression) 5 ms / < 4 ms
Dielectric Strength	(at sea level for 1 min.) 5000 VAC coil to contact 2500 VAC between open contacts 3000 VAC between contact sets
Surge voltage coil to contact	(1.2/50 μ s) 10 kV
Insulation Resistance	1000 MΩ (min.) at 20°C, 500 VDC, 50% RH
Insulation coil to contacts	Reinforced insulation (rated voltage: 250 VAC, pollution degree: 2, overvoltage category: II)
Clearance coil to contacts between open contacts between contact sets	≥ 8.0 mm ≥ 1.5 mm ≥ 3.5 mm
Creepage coil to contacts between open contacts between contact sets	≥ 8.0 mm ≥ 4.5 mm ≥ 6.5 mm
Temperature Range operating	at nominal coil voltage -40°C (-40°F) to 85°C (185°F)
Vibration	0.062" (1.5 mm) DA at 10–55 Hz
Shock	10 g
Enclosure protection category	P.B.T. polyester RT II (flux tight), RT III (wash tight)
Terminals	Tinned copper alloy, P. C.
Soldering max. temperature max. time	270°C (518°F) 5 seconds
Cleaning max. solvent temp. max. immersion time	80°C (176°F) 30 seconds
Dimensions length width height	29.0 mm (1.14") 13.0 mm (0.51") 25.9 mm (1.02")
Weight	18 grams (approx.)
Packing unit in pcs	50 per plastic tray / 500 per carton box
Compliance	UL 508, IEC 61810-1, RoHS, REACH

ZETTLER

AZ733W

COIL VOLTAGE SPECIFICATIONS

Nominal Coil VDC	Must Operate VDC	Max. Continuous VDC	Resistance Ohm $\pm 10\%$
3	2.25	4.7	11.3
5	3.8	7.9	31
6	4.5	9.5	45
9	6.8	14.2	101
12	9.0	18.9	180
18	13.5	28.4	405
24	18.0	37.9	720
48	36.0	75.9	2880
60	45.0	94.8	4500

Note: All values at 23°C (73°F), upright position, terminals downward.

ORDERING DATA

AZ733W-2A□-□□D□□

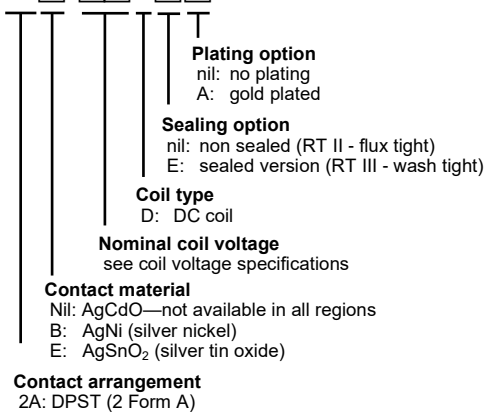

Example ordering data

AZ733W-2AE-9D silver tin oxide, 9 VDC nominal coil voltage, non sealed
AZ733W-2AB-12DA silver nickel, 12 VDC nominal coil voltage, gold plated

WIRING DIAGRAM

Viewed towards terminals

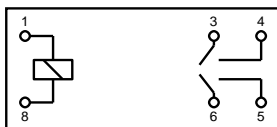

PC BOARD LAYOUT

Layout recommendation. Viewed towards terminals.
Dimensions in inches with metric equivalents in parentheses.

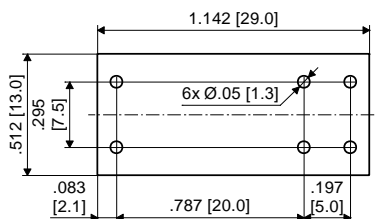

MECHANICAL DATA

Dimensions in inches with metric equivalents in parentheses. Tolerance: $\pm 0.1^*$

* Note: Pin dimensions for reference only and given without tin coating.

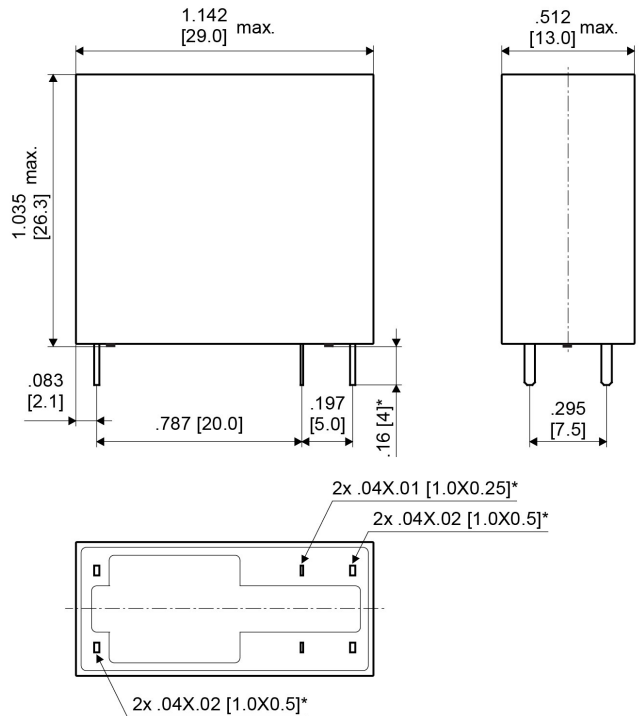

NOTES

- All values at reference temperature of 23°C (73°F) unless stated otherwise.
- Relay may pull in with less than "Must Operate" value.
- "Max. Continuous Voltage" is the maximum voltage the coil can endure for a short period of time.
- Coil suppression circuits such as diodes, etc. in parallel to the coil will lengthen the release time.
- Relay adjustment may be affected if excessive shock is applied to the relay.
- Relay adjustment may be affected if undue pressure is exerted on the relay case.
- Specifications subject to change without notice.
- For automated dual wave soldering process we recommend preheating with 120°C (248°F) for max. 120 seconds (including ramp time) and a soldering temperature of 270 ± 5 °C (500 ± 9 °F) for max. 10 seconds soldering time (5 seconds per wave) in accordance to annex N of IEC61810-1 and the IEC 61760-1 profile for wave soldering. For manual soldering we recommend 350°C (662°F) max. temperature for max. 5 seconds. During the soldering process, no force may be exerted on the relay terminals.
- Non-sealed relays must not be washed, immersion cleaned or conformal coated as substances may enter the case and cause corrosion or seizure of mechanical parts.
- With sealed versions of this relay type, the auxiliary vent hole should be cut open after washing or conformal coating to achieve the specified performance and service life. Care must be taken to ensure no particles get into the relay as a result of the cutting process.
- If washing a sealed relay, temperature of washing liquid and surface handling cleanser should be controlled below 40°C and within 10°C of component temperature. Limit pressure wash to 1.5 bar max and cleaning time to 2 minutes. A water rinse is recommended to remove cleaning agents. Never use ultrasonic wash.

ZETTLER

AZ733W

ELECTRICAL CHARACTERISTICS

Electrical life at 250 VAC, resistive load

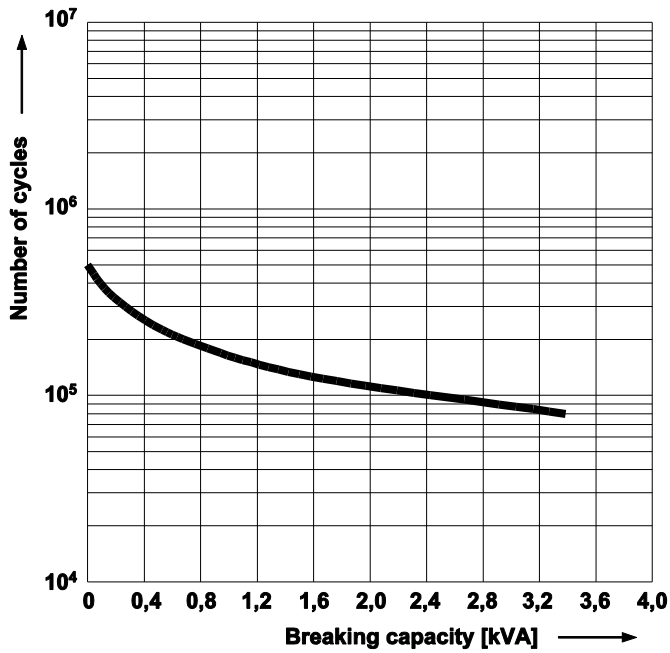

Electrical life reduction factor at inductive AC load

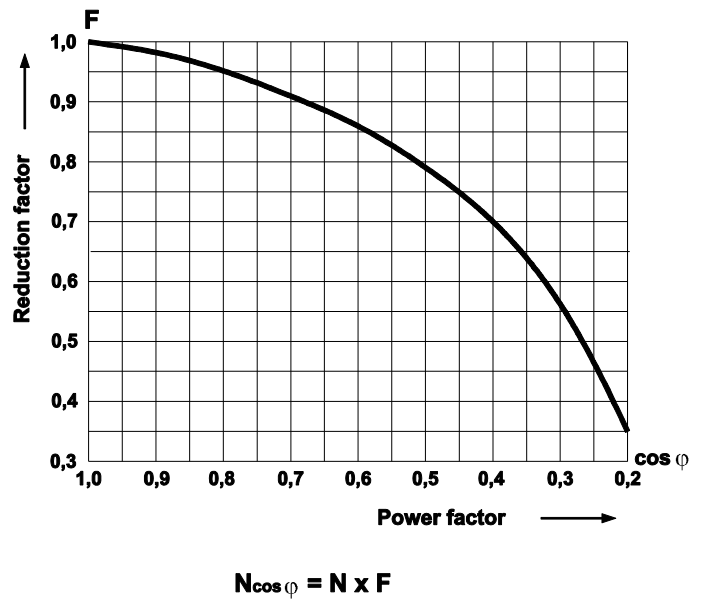

Max. AC/DC resistive load breaking capacity

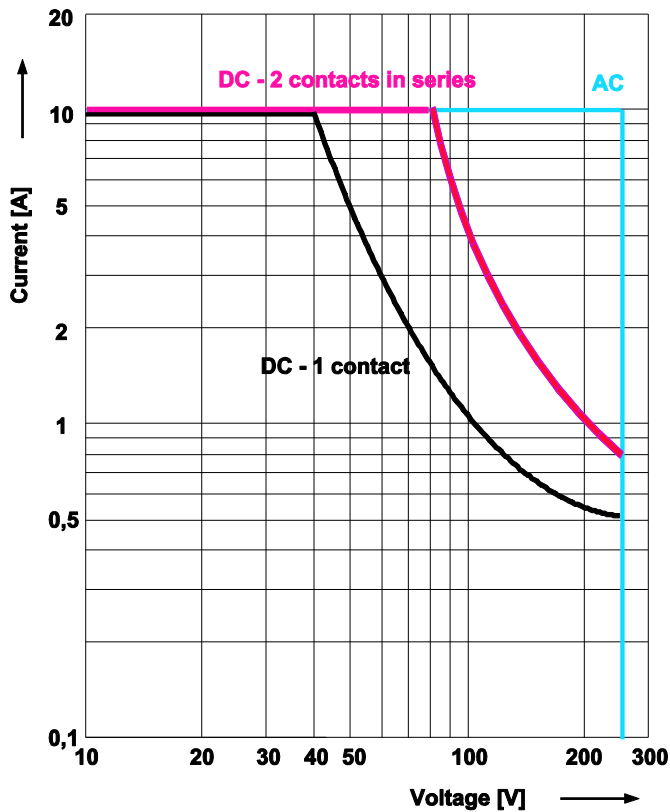

AZ733W

DISCLAIMER

This product specification is to be used in conjunction with the application notes which can be downloaded from the regional ZETTLER relay websites. The specification provides an overview of the most significant part features. Any individual applications and operating conditions are not taken into consideration. It is recommended to test the product under application conditions. Responsibility for the application remains with the customer. Proper operation and service life cannot be guaranteed if the part is operated outside the specified limits.

ZETTLER GROUP

Building on a foundation of more than a century of expertise in German precision engineering, ZETTLER Group is a world-class enterprise, engaged in the design, manufacturing, sales and distribution of electronic components. Our industry leadership is based on a unique combination of engineering competence and global scale.

For more information on other ZETTLER Group companies, please visit zettler-group.com. For support on this product or other ZETTLER relays, please visit one of the group sites below.

SITES FOR ZETTLER RELAYS

NORTH AMERICA

American Zettler, Inc.
www.azettler.com
sales@azettler.com

EUROPE

Zettler Electronics, GmbH
www.zettlerelectronics.com
office@zettlerelectronics.com

Zettler Electronics, Poland
www.zettlerelectronics.pl
office@zettlerelectronics.pl

CHINA

Zettler Group, China
www.zettlercn.com
relay@zettlercn.com

ASIA PACIFIC



Zettler Electronics (HK) Ltd.
www.zettlerhk.com
sales@zettlerhk.com



ZETTLER

Looking for pricing, stock, or lifecycle information?

Click below to explore more details on WIN SOURCE:

-  [View AZ733W-2AE-12DE on WIN SOURCE](#)
-  [American Zettler, Inc. Information](#)

Optimize Your Supply Chain with WIN SOURCE Solutions

-  Global Sourcing Solution
-  Obsolete Management
-  Cost Control Management
-  Shortage Management
-  Alternative Solution
-  Excess Inventory Management