



**THE DATASHEET OF
DG506ACJ+**





Monolithic CMOS Analog Multiplexers

General Description

Maxim's DG506A/DG507A are monolithic CMOS analog multiplexers. The DG506A is a single 16-channel (1 of 16) multiplexer and the DG507A is a differential 8-channel (2 of 16) multiplexer.

Both devices feature break-before-make switching. Maxim guarantees that these multiplexers will not latch-up if the power supplies are turned off with the input signals still present as long as absolute maximum ratings are not violated. The multiplexers operate over a wide range of power supplies from $\pm 4.5\text{V}$ to $\pm 18\text{V}$.

Compared to the original manufacturer's devices, Maxim's DG506A/DG507A consume significantly less power, making them ideal for portable equipment.

Maxim's DG506A/DG507A meet or exceed the specifications of, and are drop-in replacements for Intersil's IH6116 and IH6216, Siliconix's DG506A and DG507A, and Harris' HI506 and HI507.

Applications

- Control Systems
- Data Logging Systems
- Aircraft Heads Up Displays
- Data Acquisition Systems
- Signal Routing

Typical Operating Circuit

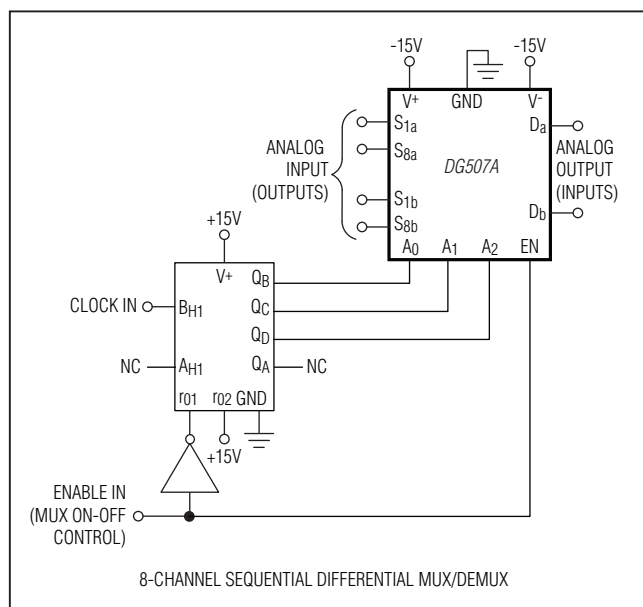

Features

- ◆ Improved 2nd Source
- ◆ Pin Compatible with Harris, Siliconix, Intersil
- ◆ Operable with $\pm 4.5\text{V}$ to $\pm 18\text{V}$ Supplies
- ◆ Symmetrical, Bidirectional Operation
- ◆ Logic and Enable Inputs, TTL and CMOS Compatible
- ◆ Latch-Up Proof Construction
- ◆ Monolithic, Low-Power CMOS Design

Ordering Information

PART†	TEMP RANGE	PIN-PACKAGE
DG506AAK	-55°C to +125°C	28 CERDIP
DG506ABK	-25°C to +85°C	28 CERDIP
DG506AC/D	0°C to +70°C	Dice
DG506ACJ	0°C to +70°C	28 Plastic Dip
DG506ACK	0°C to +70°C	28 CERDIP
DG506ACWI	0°C to +70°C	28 Wide SO
DG506AMWI/PR	-55°C to +125°C	28 Wide SO
DG506AAZ/833B	-55°C to +125°C	28 LCC
DG507AAK	-55°C to +125°C	28 CERDIP
DG507ABK	-25°C to +85°C	28 CERDIP
DG507AC/D	0°C to +70°C	Dice
DG507ACJ	0°C to +70°C	28 Plastic DIP
DG507ACK	0°C to +70°C	28 CERDIP
DG507ACWI	0°C to +70°C	28 Wide SO

†Devices are available in a lead(Pb)-free/RoHS-compliant package, specify lead-free by adding "+" to the part number when ordering.

Pin Configurations

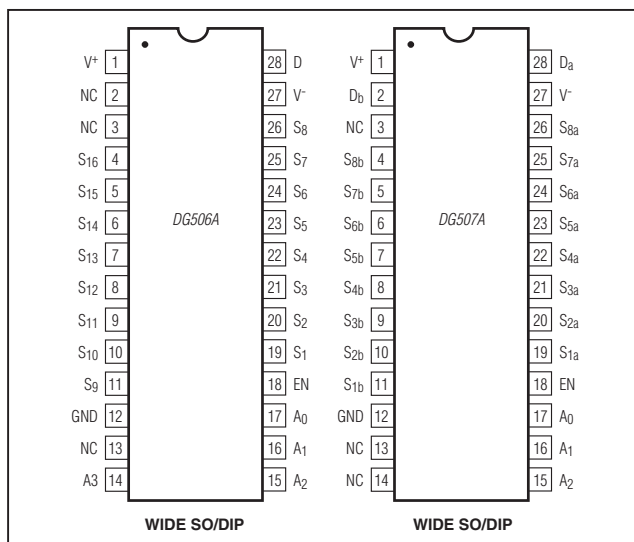

Pin Configurations continued in middle of data sheet.

Monolithic CMOS Analog Multiplexers

DG506A/DG507A

ABSOLUTE MAXIMUM RATINGS

(Voltages referenced to V⁻.)

V ⁺	44V
GND.....	25V
Digital Inputs V _S , V _D (Note 1)	-2V to (V ⁺ + 2V) or 20mA, whichever occurs first
Current, Any Terminal Except S or D.....	30mA
Continuous Current, S or D.....	20mA
Peak Current, S or D (pulsed at 1ms, 10% duty cycle max)...	40mA
Continuous Power Dissipation (T _A = +70°C)*	
28-Pin Ceramic DIP (derate 16.7mW/°C above +70°C) ..	1333mW
28-Pin Plastic DIP (derate 14.3mW/°C above +70°C) ..	1143mW

28-Pin Wide SO (derate 12.5mW/°C above +70°C) ..	1000mW
28-Pin LCC (derate 10.2mW/°C above +70°C)	816.3mW
Operating Temperature Range (A Suffix)	-55°C to +125°C
(B Suffix)	-25°C to +85°C
(C Suffix)	0°C to +70°C
Storage Temperature (A and B Suffix).....	-65°C to +150°C
(C Suffix)	-65°C to +125°C
Lead Temperature (soldering, 10s)	+300°C
Soldering Temperature (reflow)	
Lead (Pb)-free packages	+260°C
Packages containing lead (Pb).....	+240°C

*All leads soldered or welded to PCB.

Stresses beyond those listed under "Absolute Maximum Ratings" may cause permanent damage to the device. These are stress ratings only, and functional operation of the device at these or any other conditions beyond those indicated in the operational sections of the specifications is not implied. Exposure to absolute maximum rating conditions for extended periods may affect device reliability.

ELECTRICAL CHARACTERISTICS

(V⁺ = 15V, V⁻ = -15V, V_{GND} = 0V, T_A = +25°C, unless otherwise indicated.)

PARAMETER	SYMBOL	CONDITIONS	DG506AA DG507AA			DG506AB/C DG507AB/C			UNITS	
			MIN (Note 2)	TYP (Note 3)	MAX	MIN (Note 2)	TYP (Note 3)	MAX		
SWITCH										
Analog Signal Range	V _{ANALOG}		-15		+15	-15		+15	V	
Drain-to-Source On-Resistance	R _{DS(ON)}	Sequence each switch on, V _{AL} = 0.8V, V _{AH} = 2.4V, V _{EN} = 2.4V	V _D = 10V, I _S = -200μA	270	400	270	450		Ω	
			V _D = -10V, I _S = -200μA	230	400	230	450			
Greatest Change in Drain-Source On-Resistance Between Channels	R _{DS(ON)}	$\Delta R_{DS(ON)} = \left(\frac{R_{DS(ON)MAX} - R_{DS(ON)MIN}}{R_{DS(ON)AVE}} \right)$ -10V ≤ V _S ≤ +10V		6			6		%	
Source Off-Leakage Current	I _{S(OFF)}	V _{EN} = 0.8V, V _{AL} = 0.8V	V _S = 10V, V _D = -10V	-1	0.002	+1	-5	0.002	+5	nA
			V _S = -10V, V _D = 10V	-1	-0.005	+1	-5	-0.005	+5	
Drain Off-Leakage Current	I _{D(OFF)}	DG506A, V _{EN} = 0.8V, V _{AL} = 0.8V	V _D = 10V, V _S = -10V	-10	0.02	+10	-20	0.02	+20	nA
			V _D = -10V, V _S = 10V	-10	-0.03	+10	-20	-0.03	+20	
		DG507A, V _{EN} = 0.8V, V _{AL} = 0.8V	V _D = 10V, V _S = -10V	-5	0.007	+5	-10	0.007	+10	
			V _D = -10V, V _S = 10V	-5	-0.015	+5	-10	-0.015	+10	

Monolithic CMOS Analog Multiplexers

ELECTRICAL CHARACTERISTICS (continued)

(V₊ = 15V, V₋ = -15V, V_{GND} = 0V, T_A = +25°C, unless otherwise indicated.)

DG506A/DG507A

PARAMETER	SYMBOL	CONDITIONS		DG506AA DG507AA			DG506AB/C DG507AB/C			UNITS
				MIN (Note 2)	TYP (Note 3)	MAX	MIN (Note 2)	TYP (Note 3)	MAX	
Channel On-Leakage Current	I _{D(ON)} (Note 4)	DG506A, sequence each switch on, V _{AL} = 0.8V, V _{AH} = 2.4V, V _{EN} = 2.4V	V _{S(all)} = V _D = 10V	-10	0.03	+10	-20	0.03	+20	nA
			V _{S(all)} = V _D = -10V	-10	-0.06	+10	-20	-0.06	+20	
		DG507A, sequence each switch on, V _{AL} = 0.8V, V _{AH} = 2.4V, V _{EN} = 2.4V	V _{S(all)} = V _D = 10V	-5	0.015	+5	-10	0.015	+10	
			V _{S(all)} = V _D = -10V	-5	-0.03	+5	-10	-0.03	+10	
INPUT										
Address Input Current, Input- Voltage High	I _{AH}	V _A = 2.4V		-10	-0.002		-10	-0.002		μA
		V _A = 15V			0.006	10		0.006	10	
Address Input Current, Input- Voltage Low	I _{AL}	All V _A = 0V	V _{EN} = 2.4V	-10	-0.002		-10	-0.002		μA
			V _{EN} = 0V	-10	-0.002		-10	-0.002		
DYNAMIC										
Switching Time of Multiplexer	t _{transition}	Figure 1			0.6	1		0.06		μs
Break-Before- Make Interval	t _{OPEN}	Figure 3			0.2			0.2		μs
Enable Turn- On Time	t _{ON(EN)}	Figure 2			1			1		μs
Enable Turn- Off Time	t _{OFF(EN)}	Figure 2			0.4			0.4		μs
Off-Isolation (Note 5)	OIRR	V _{EN} = 0V, R _L = 1kΩ, C _L = 15pF, V _S = 7V _{RMS} , f = 500kHz			68			68		dB
Source Off- Capacitance	C _{S(OFF)}	V _{EN} = 0V, f = 140kHz, V _S = 0V			6			6		pF
Drain Off- Capacitance	C _{D(OFF)}	V _{EN} = 0V, f = 140kHz			45			45		pF
		DG507A, V _D = 0V			23			23		
SUPPLY										
Positive Supply Current	I ₊	V _{EN} = 0 or 5V, all V _A = 0V			0.13	0.25		0.13	0.3	mA
Negative Supply Current	I ₋	V _{EN} = 0 or 5V, all V _A = 0V		-0.15	-0.07		-0.25	-0.07		

Monolithic CMOS Analog Multiplexers

DG506A/DG507A

ELECTRICAL CHARACTERISTICS (Overtemperature)

(V+ = 15V, V- = -15V, VGND = 0V, TA = overtemperature range, unless otherwise noted.)

PARAMETER	SYMBOL	CONDITIONS		DG506AA DG507AA			DG506AB/C DG507AB/C			UNITS
				MIN (Note 2)	TYP (Note 3)	MAX	MIN (Note 2)	TYP (Note 3)	MAX	
SWITCH										
Analog Signal Range	VANALOG			-15		+15	-15		+15	V
Drain-to-Source On-Resistance	RDS(ON)	Sequence each switch on, VAL = 0.8V, VAH = 2.4V, VEN = 2.4V	VD = 10V, IS = -200μA		500			550		Ω
			VD = -10V, IS = -200μA		500			550		
Source Off-Leakage Current	IS(OFF)	VEN = 0.8V, VAL = 0.8V	VS = 10V, VD = -10V	-50		+50	-50		+50	nA
			VS = -10V, VD = 10V	-50		+50	-50		+50	
Drain Off-Leakage Current	ID(OFF)	DG506A, VEN = 0.8V, VAL = 0.8V	VD = 10V, VS = -10V	-300		+300	-300		+300	nA
			VD = -10V, VS = 10V	-300		+300	-300		+300	
		DG507A, VEN = 0.8V, VAL = 0.8V	VD = 10V, VS = -10V	-200		+200	-200		+200	
			VD = -10V, VS = 10V	-200		+200	-200		+200	
Channel On-Leakage Current	ID(ON) (Note 4)	DG506A, sequence each switch on, VAL = 0.8V, VAN = 2.4V, VEN = 2.4V	VS(all) = VD = 10V	-300		+300	-300		+300	nA
			VS(all) = VD = -10V	-300		+300	-300		+300	
		DG507A, sequence each switch on, VAL = 0.8V, VAN = 2.4V, VEN = 2.4V	VS(all) = VD = 10V	-200		+200	-200		+200	
			VS(all) = VD = -10V	-200		+200	-200		+200	
INPUT										
Address Input Current, Input-Voltage High	IAH	VA = 2.4V		-30			-30			μA
		VA = 15V				30		30		
Address Input Current, Input-Voltage Low	IAL	All VA = 0V	VEN = 2.4V	-30			-30			μA
			VEN = 0V				30		30	

Monolithic CMOS Analog Multiplexers

ELECTRICAL CHARACTERISTICS (Overtemperature) (continued)

(V+ = 15V, V- = -15V, VGND = 0V, TA = over temperature range, unless otherwise noted.)

- Note 1:** Signals on SX, DX, or INX exceeding V+ or V- will be clamped by internal diodes. Limit forward diode current to maximum current ratings.
- Note 2:** The algebraic convention whereby the most negative value is a minimum, and the most positive value is a maximum, is used in this data sheet.
- Note 3:** Typical values are for design aid only, not guaranteed nor subject to production testing.
- Note 4:** ID(ON) is leakage from driver into on switch.
- Note 5:** Off-isolation = 20log x VO/VS, VS = input to off switch, VD = output due to VS.

Truth Tables

A3	A2	A1	A0	EN	ON SWITCH
X	X	X	X	0	None
0	0	0	0	1	1
0	0	0	1	1	2
0	0	1	0	1	3
0	0	1	1	1	4
0	1	0	0	1	5
0	1	0	1	1	6
0	1	1	0	1	7
0	1	1	1	1	8
1	0	0	0	1	9
1	0	0	1	1	10
1	0	1	0	1	11
1	0	1	1	1	12
1	1	0	0	1	13
1	1	0	1	1	14
1	1	1	0	1	15
1	1	1	1	1	16

A2	A1	A0	EN	ON SWITCH
X	X	X	0	None
0	0	0	1	1
0	0	1	1	2
0	1	0	1	3
0	1	1	1	4
1	0	0	1	5
1	0	1	1	6
1	1	0	1	7
1	1	1	1	8

Note: Logic "0" = VAL ≤ 0.8V, Logic "1" = VAH ≥ 2.4V, "0" = Don't Care.

Switching Time Test Circuits

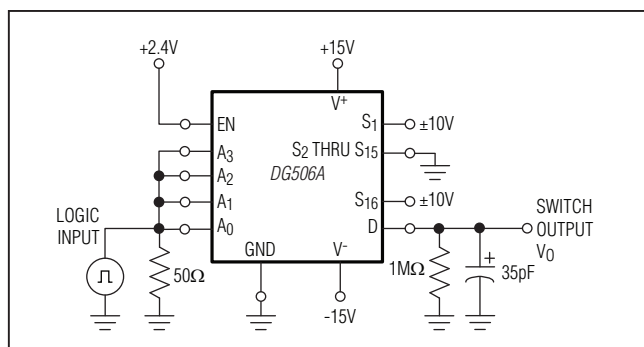

Figure 1a. Transition Switching Time

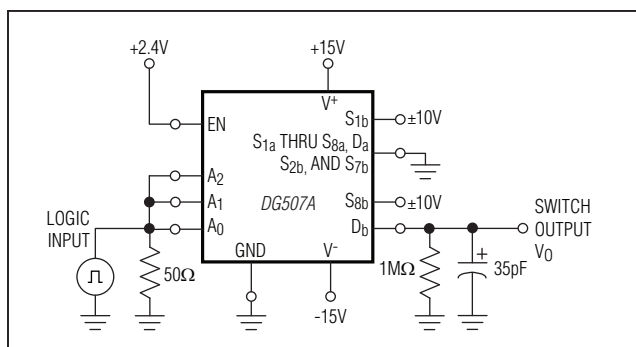

Figure 1b. Transition Switching Time

Monolithic CMOS Analog Multiplexers

Switching Time Test Circuits (continued)

DG506A/DG507A

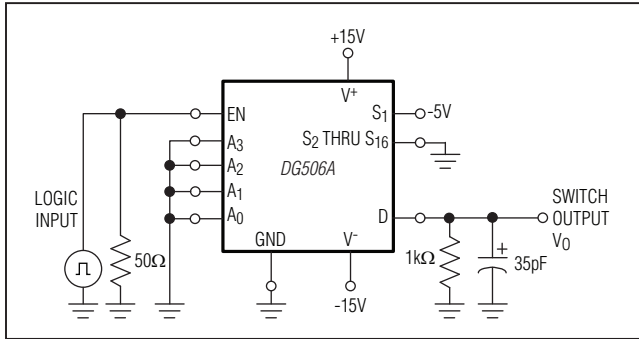

Figure 2a. Enable Switching Time

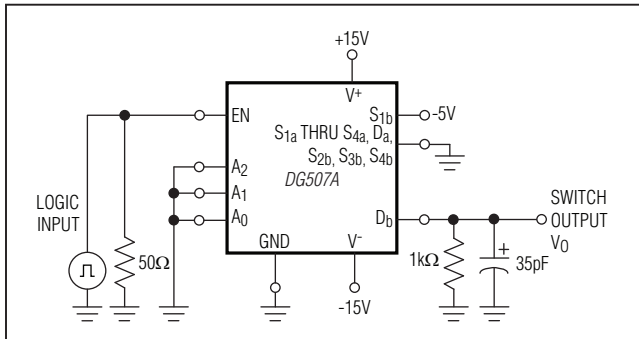

Figure 2b. Enable Switching Time

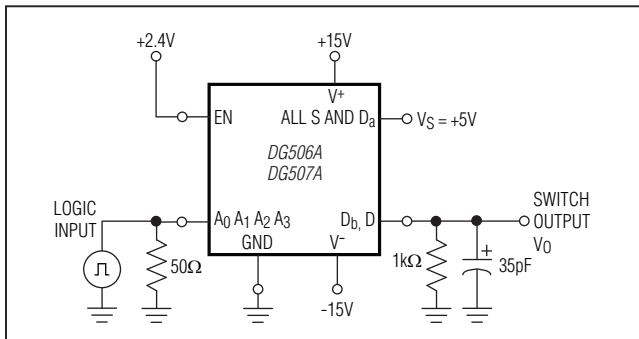

Figure 3. Break-Before-Make

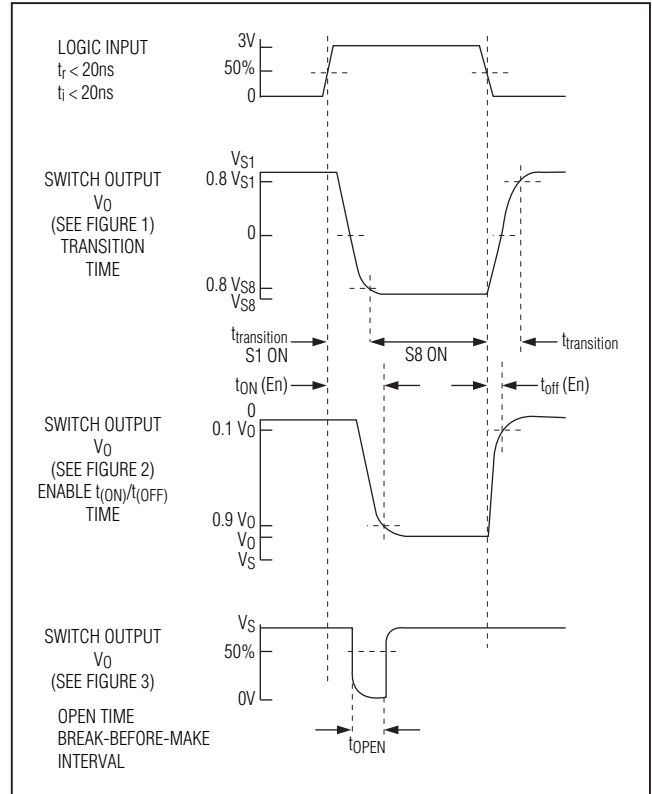
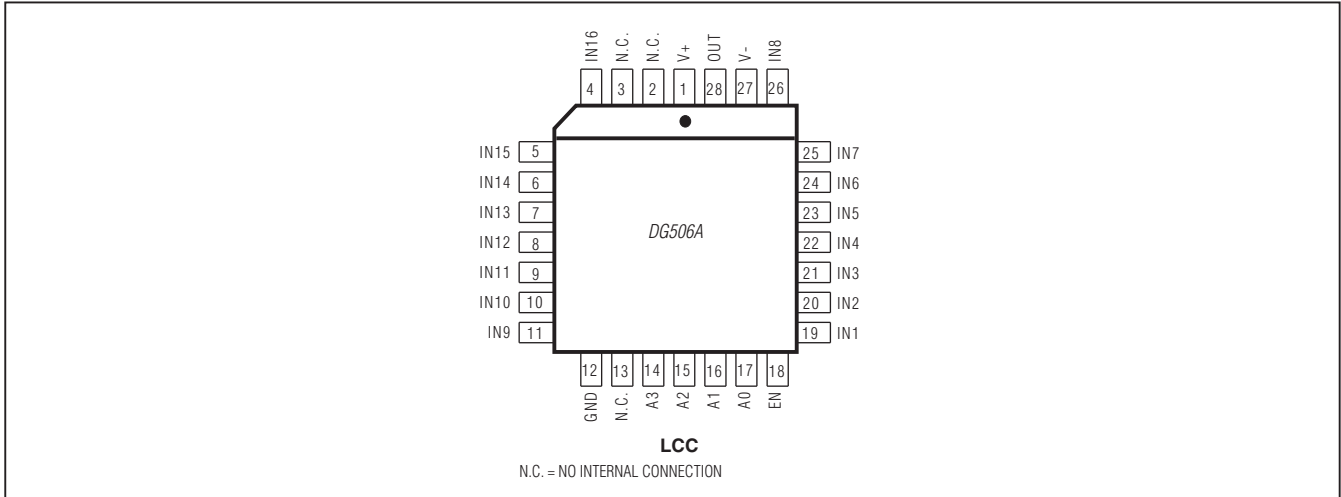

Figure 4. Timing Diagrams for Figures 1, 2, and 3

Monolithic CMOS Analog Multiplexers

Pin Configurations (continued)

DG506A/DG507A



Pin Description

PIN		NAME	FUNCTION
DG506A DIP / SO	DG507A DIP / SO		
1	1	V+	Positive Supply Voltage Input
2, 3	3	N.C.	No Connection. Internally not connected.
—	2	D _b	Analog Output Bidirectional Channel b
4	—	S ₁₆	Analog Output Bidirectional Channel 16
—	4	S _{8b}	Analog Output Bidirectional Channel 8b
5	—	S ₁₅	Analog Output Bidirectional Channel 15
—	5	S _{7b}	Analog Output Bidirectional Channel 7b
6	—	S ₁₄	Analog Output Bidirectional Channel 14
—	6	S _{6b}	Analog Output Bidirectional Channel 6b
7	—	S ₁₃	Analog Output Bidirectional Channel 13
—	7	S _{5b}	Analog Output Bidirectional Channel 5b
8	—	S ₁₂	Analog Output Bidirectional Channel 12
—	8	S _{4b}	Analog Output Bidirectional Channel 4b
9	—	S ₁₁	Analog Output Bidirectional Channel 11
—	9	S _{3b}	Analog Output Bidirectional Channel 3b
10	—	S ₁₀	Analog Output Bidirectional Channel 10
—	10	S _{2b}	Analog Output Bidirectional Channel 2b
11	—	S ₉	Analog Output Bidirectional Channel 9
—	11	S _{1b}	Analog Output Bidirectional Channel 1b
12	12	GND	Ground

Monolithic CMOS Analog Multiplexers

Pin Description (continued)

DG506A/DG507A

PIN		NAME	FUNCTION
DG506A DIP / SO	DG507A DIP / SO		
13	13, 14	N.C.	No Connection. Not internally connected.
14	—	A3	Address Input A3
15	15	A2	Address Input A2
16	16	A1	Address Input A1
17	17	A0	Address Input A0
18	18	EN	Enable Input
19	—	S ₁	Analog Output Bidirectional Channel 1
—	19	S _{1A}	Analog Output Bidirectional Channel 1a
20	—	S ₂	Analog Output Bidirectional Channel 2
—	20	S _{2A}	Analog Output Bidirectional Channel 2a
21	—	S ₃	Analog Output Bidirectional Channel 3
—	21	S _{3A}	Analog Output Bidirectional Channel 3a
22	—	S ₄	Analog Output Bidirectional Channel 4
—	22	S _{4A}	Analog Output Bidirectional Channel 5
23	—	S ₅	Analog Output Bidirectional Channel 5a
—	23	S _{5a}	Analog Output Bidirectional Channel 6
24	—	S ₆	Analog Output Bidirectional Channel 6a
—	24	S _{6a}	Analog Output Bidirectional Channel 7
25	—	S ₇	Analog Output Bidirectional Channel 7a
—	25	S _{7a}	Analog Output Bidirectional Channel 8
26	—	S ₈	Analog Output Bidirectional Channel 8a
—	26	S _{8a}	Analog Output Bidirectional Channel
27	27	V-	Negative Supply Voltage Input
28	—	D	Analog Output Bidirectional
—	28	Da	Analog Output Bidirectional Channel a

Monolithic CMOS Analog Multiplexers

Pin Description (continued)

DG506A/DG507A

PIN	NAME	FUNCTION
DG506A LCC		
1	V+	Positive Supply Voltage Input
2, 3	N.C.	NoConnection. Internally not connected.
4	IN ₁₆	Analog Input Bidirectional Channel 16
5	IN ₁₅	Analog Input Bidirectional Channel 15
6	IN ₁₄	Analog Input Bidirectional Channel 14
7	IN ₁₃	Analog Input Bidirectional Channel 13
8	IN ₁₂	Analog Input Bidirectional Channel 12
9	IN ₁₁	Analog Input Bidirectional Channel 11
10	IN ₁₀	Analog Input Bidirectional Channel 10
11	IN ₉	Analog Input Bidirectional Channel 9
12	GND	Ground
13	N.C.	No Connection. Not internally connected.
14	A3	Address Input A3
15	A2	Address Input A2
16	A1	Address Input A1
17	A0	Address Input A0
18	EN	Enable Input
19	IN ₁	Analog Input Bidirectional Channel 1
20	IN ₂	Analog Input Bidirectional Channel 2
21	IN ₃	Analog Input Bidirectional Channel 3
22	IN ₄	Analog Input Bidirectional Channel 4
23	IN ₅	Analog Input Bidirectional Channel 5
24	IN ₆	Analog Input Bidirectional Channel 6
25	IN ₇	Analog Input Bidirectional Channel 7
26	IN ₈	Analog Input Bidirectional Channel 8
27	V-	Negative Supply Voltage Input
28	OUT	Analog Output Bidirectional

Package Information

For the latest package outline information and land patterns, go to www.maxim-ic.com/packages. Note that a "+", "#", or "-" in the package code indicates RoHS status only. Package drawings may show a different suffix number, but the drawing pertains to the package regardless of RoHS status.

PACKAGE TYPE	PACKAGE CODE	OUTLINE NO.	LAND PATTERN NO.
28 CERDIP	J28-2	21-0046	—
28 Plastic DIP	P28-2	21-0044	—
28 Wide SO	W28-5	21-0042	90-0109
28 Wide SO	W28-5	21-0047	90-0178
28 LCC	L28-2	21-4497	90-0178

Monolithic CMOS Analog Multiplexers

Revision History

REVISION NUMBER	REVISION DATE	DESCRIPTION	PAGES CHANGED
0	8/92	Initial release	—
1	1/99	Updated to Word format.	1–7
2	5/09	Added ruggedized plastic part.	1–4, 7
3	2/10	<ul style="list-style-type: none">Added lead temperature to the <i>Absolute Maximum Ratings</i>.Changed the derate rate of all packages to above 70°C in the <i>Absolute Maximum Ratings</i>.	2
4	6/12	Added DG506AAZ/883B; added the Pin Descriptions for DG506A DIP/SO, DG507A DIP/SO, DG506A LCC; added LCC Pin Configuration for the DG506A	1, 2, 7, 9

DG506A/DG507A

Maxim cannot assume responsibility for use of any circuitry other than circuitry entirely embodied in a Maxim product. No circuit patent licenses are implied. Maxim reserves the right to change the circuitry and specifications without notice at any time. The parametric values (min and max limits) shown in the Electrical Characteristics table are guaranteed. Other parametric values quoted in this data sheet are provided for guidance.

10 **Maxim Integrated Products, Inc. 160 Rio Robles, San Jose, CA 95134 USA 1-408-601-1000**

© 2012 Maxim Integrated Products

Maxim is a registered trademark of Maxim Integrated Products, Inc.

Looking for pricing, stock, or lifecycle information?

Click below to explore more details on WIN SOURCE:

 [View DG506ACJ+](#) on WIN SOURCE

 [Maxim Integrated](#) Information

Optimize Your Supply Chain with WIN SOURCE Solutions

-  Global Sourcing Solution
-  Obsolete Management
-  Cost Control Management
-  Shortage Management
-  Alternative Solution
-  Excess Inventory Management