



**THE DATASHEET OF
TPS7H3301HKR/EM**



TPS7H3301-SP Sink and Source Radiation-Hardened 3-A DDR Termination Regulator With Built-In VTTREF Buffer

1 Features

- [5962R14228](#)⁽¹⁾:
 - Radiation hardness assurance (RHA) qualified to total ionizing dose (TID) 100 krad(Si)
 - Single event latch-up (SEL), single event gate rupture (SEGR), single event burnout (SEB) immune to LET = 70 MeV-cm²/mg⁽²⁾
 - Single event transient (SET), single event functional interrupt (SEFI), and single event upset (SEU) characterized to 70 MeV-cm²/mg⁽²⁾
- Supports DDR, DDR2, DDR3, DDR3L, and DDR4 termination applications
- Input voltage: supports a 2.5-V and 3.3-V rail⁽³⁾
- Separate low-voltage input (VLDOIN) down to 0.9 V for improved power efficiency⁽³⁾
- 3-A sink and source termination regulator includes droop compensation
- Enable input and power-good output for power supply sequencing
- VTT termination regulator
 - Output voltage range: 0.5 to 1.75 V
 - 3-A sink and source current
- Integrated precision voltage divider network with sense input
- Remote sensing (VTTSENS)
- VTTREF buffered reference
 - ±15-mV accuracy
 - ±10-mA sink and source current
- Undervoltage lockout (UVLO) and overcurrent limit (OCL) functionality integrated

2 Applications

- [Command and data handling \(C&DH\)](#)
- [Optical imaging payload](#)
- [Radar imaging payload](#)

3 Description

The TPS7H3301-SP is a TID and SEE radiation-hardened double data rate (DDR) 3-A termination regulator with built-in VTTREF buffer. The regulator is specifically designed to provide a complete, compact, low-noise solution for space DDR termination applications such as single board computers, solid state recorders, and payload processing.

The TPS7H3301-SP supports DDR VTT termination applications using DDR, DDR2, DDR3, DDR4. The fast transient response of the TPS7H3301-SP VTT regulator allows for a very stable supply during read/write conditions. During transients, the fast tracking feature of the VTTREF supply minimizes any voltage offset between VTT/V_O and VTTREF. To enable simple power sequencing, both an enable input and a power-good output (PGOOD) have been integrated into the TPS7H3301-SP. The PGOOD output is open-drain so it can be tied to multiple open-drain outputs to monitor when all supplies have come into regulation. The enable signal can also be used to discharge VTT/V_O during suspend to RAM (S3) power down mode.

Device Information⁽¹⁾

PART NUMBER	GRADE	PACKAGE
5962R1422801VXC	Flight Grade RHA 100 krad(Si)	16-Pin CFP 9.60 mm x 11.00 mm Weight: 1.55 g ⁽⁵⁾
5962-1422801VXC	Flight Grade QMLV	
TPS7H3301HKR/EM	Engineering Module ⁽⁴⁾	
TPS7H3301EVM-CVAL	Ceramic Evaluation Board	EVM

(1) For all available packages, see the orderable addendum at the end of the data sheet.

(2) See [Radiation Report](#) for details.

(3) Applicable to DDR2, DDR3, DDR3L and DDR4. For DDR, input voltage = 3.3-V nominal. V_{IN} is 2.95 to 3.5 V for DDR1 and V_{LDOIN} > V_{TT/V_O} for all DDRs. For DDR2 3-A load condition, V_{IN} is 2.45 to 3.5 V. V_{IN_MIN} ≥ V_{TT/V_O} + 1.5 V.

(4) These units are intended for engineering evaluation only. They are processed to a noncompliant flow (that is, no burn-in, and so forth) and are tested to a temperature rating of 25°C only. These units are not suitable for qualification, production, radiation testing or flight use. Parts are not warranted for performance over the full MIL specified temperature range of –55°C to 125°C or operating life.

(5) Weight is accurate to ±10%.

Standard DDR Application

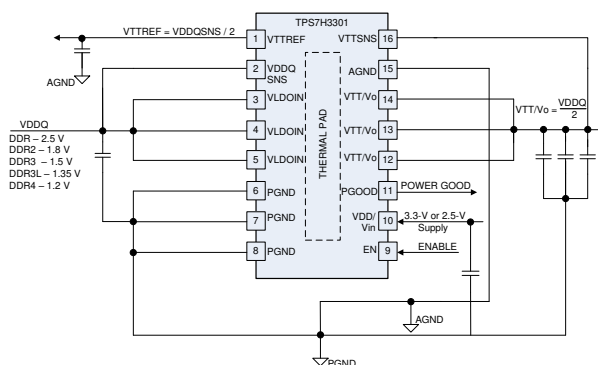

Table of Contents

1 Features	1	8 Application and Implementation	14
2 Applications	1	8.1 Application Information.....	14
3 Description	1	8.2 Typical Application	14
4 Revision History	2	9 Power Supply Recommendations	22
5 Pin Configuration and Functions	4	10 Layout	23
6 Specifications	5	10.1 Layout Guidelines	23
6.1 Absolute Maximum Ratings	5	10.2 Layout Example	23
6.2 ESD Ratings.....	5	10.3 Thermal Considerations	24
6.3 Recommended Operating Conditions.....	5	11 Device and Documentation Support	25
6.4 Thermal Information	5	11.1 Device Support.....	25
6.5 Electrical Characteristics.....	6	11.2 Documentation Support	25
6.6 Typical Characteristics	8	11.3 Receiving Notification of Documentation Updates	25
7 Detailed Description	11	11.4 Support Resources	25
7.1 Overview	11	11.5 Trademarks	25
7.2 Functional Block Diagram	11	11.6 Electrostatic Discharge Caution.....	25
7.3 Feature Description.....	11	11.7 Glossary	25
7.4 Device Functional Modes.....	13	12 Mechanical, Packaging, and Orderable Information	25

4 Revision History

Changes from Revision A (June 2016) to Revision B

Page

• Changed DLA drawing number	1
• Changed radiation performance feature summary	1
• Changed feature description for supported DDR termination applications	1
• Changed VTTREF accuracy feature	1
• Changed description of supported DDR applications	1
• Added package weight to Device Information table	1
• Changed pin name references throughout document to be consistent	4
• Added additional thermal metrics	5
• Added clarification of T_J temperature range in <i>Electrical Characteristics</i> table.....	6
• Changed ambiguous tolerance specification for V_{TT}/V_O to explicitly specify min/max range	6
• Changed UVLO threshold hysteresis to own table entry	7
• Changed naming on VTTREF plots for consistency	8
• Added ceramic to capacitor description to meet stability requirements	12
• Added correct cross reference for output current limit	12
• Changed wording for clarity for V_{IN}/V_{DD}	15
• Changed comment to reflect total ESR	15
• JEDEC specification references	19
• Changed to improved transient plot and description	20
• Added or smaller for layout thermal via size	23
• Changed to improved recommended layout diagram.	23
• Changed wording to clarify power dissipation description	24

Changes from Original (December 2015) to Revision A
Page

• Changed title of data sheet.....	1
• Added new RHA device features.....	1
• Deleted soft start feature statement	1
• Deleted built-in VREF statement	1
• Deleted misplaced pin function.....	4
• Changed absolute maximum rating for EN pin to 3.6 V	5
• Deleted specification for PG pin sink current	5
• Deleted specification for peak output current.....	5
• Deleted unnecessary graphs from the <i>Typical Characteristics</i> section.....	8
• Changed typo for VTTREF disabling lower threshold from 0.375 to 0.76 V	12
• Edited content to reflect there is no built-in soft start and added details regarding tracking at startup	16

5 Pin Configuration and Functions

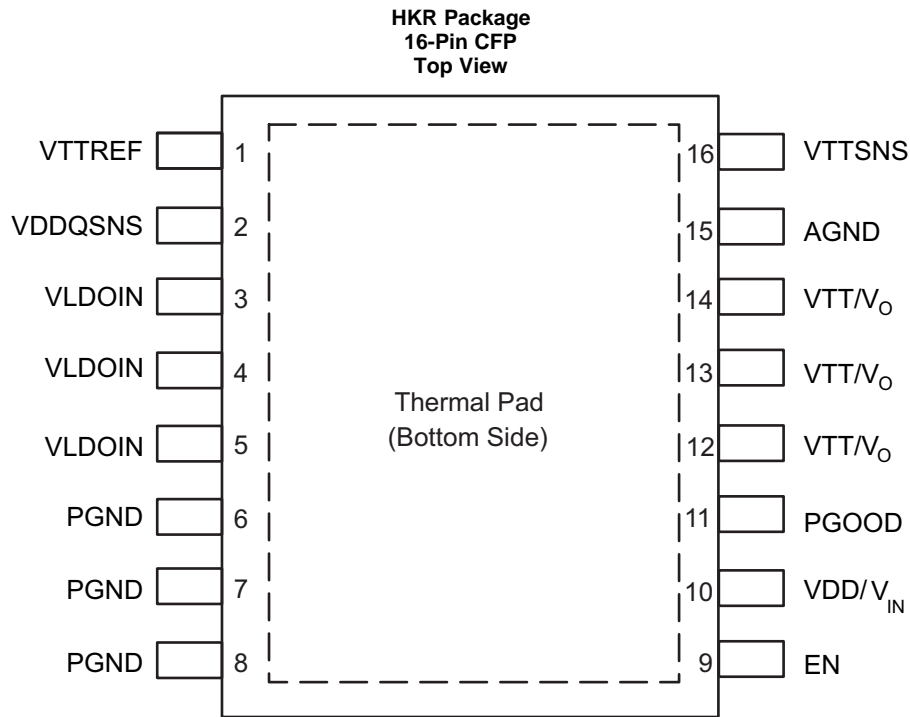

Pin Functions

PIN		I/O	DESCRIPTION
NAME	NO.		
VTTREF	1	O	Reference output. Connect to GND through 0.1- μ F ceramic capacitor.
VDDQSNS	2	I	VDDQ sense input. Reference input for VTTREF.
VLDOIN	3	I	Supply voltage for the LDO. Connect to VDDQ voltage or an alternate voltage source.
	4		
	5		
PGND	6	—	Power ground. Connect output for the VTT/ V_O LDO to negative pin of the output capacitor.
	7		
	8		
EN	9	I	Enable pin. Driving this pin to logic high enables the device; driving this pin to logic low disables the device.
VDD/ V_{IN}	10	I	2.5- or 3.3-V power supply. A ceramic decoupling capacitor with a value between 1 and 10 μ F is required.
PGOOD	11	O	PGOOD output pin. PGOOD pin is an open drain output to indicate the output voltage is within specification.
VTT/ V_O	12	O	Power output for VTT/ V_O LDO.
	13		
	14		
AGND	15	—	Signal ground. Connect to negative pin of output capacitors. ⁽¹⁾
VTTSENS	16	I	Voltage sense for VTT/ V_O . Connect to positive pin of the output capacitor or the load.

(1) Thermal pad and package lid are internally connected to ground.

6 Specifications

6.1 Absolute Maximum Ratings

over operating temperature, unless otherwise noted⁽¹⁾

		MIN	MAX	UNIT
Input voltage ⁽²⁾	VDD/V _{IN} , VLDOIN, VTTSNS, VDDQSNS	-0.36	3.6	V
	EN	-0.3	3.6	
	PGND to AGND	-0.3	0.3	
Output voltage ⁽²⁾	VTT/V _O , VTTREF	-0.3	3.6	V
	PGOOD	-0.3	3.6	
T _J	Operating junction temperature	-55	150	°C
T _{stg}	Storage temperature	-55	150	°C

- Stresses beyond those listed under *Absolute Maximum Ratings* may cause permanent damage to the device. These are stress ratings only and functional operation of the device at these or any other conditions beyond those indicated under *Recommended Operating Conditions* is not implied. Exposure to absolute-maximum-rated conditions for extended periods may affect device reliability.
- All voltage values are with respect to the network ground (AGND) pin unless otherwise noted.

6.2 ESD Ratings

		VALUE	UNIT
V _(ESD)	Electrostatic discharge		
	Human-body model (HBM), per ANSI/ESDA/JEDEC JS-001, all pins ⁽¹⁾	±4000	V
Charged-device model (CDM), per JEDEC specification JESD22-C101, all pins ⁽²⁾	±750		

- JEDEC document JEP155 states that 500-V HBM allows safe manufacturing with a standard ESD control process.
- JEDEC document JEP157 states that 250-V CDM allows safe manufacturing with a standard ESD control process.

6.3 Recommended Operating Conditions

All voltage values are with respect to the network ground (AGND) pin unless otherwise noted

		MIN	NOM	MAX	UNIT
Supply voltage	VDD/V _{IN}	2.375		3.5	V
Voltage	VLDOIN	0.9		3.5	V
	EN, VTTSNS	-0.1		3.5	
	VDDQSNS	1		3.5	
	VTT/V _O , PGOOD	-0.1		3.5	
	VTTREF	-0.1		1.8	
	PGND	-0.1		0.1	
T _J	Operating junction temperature	-55		125	°C

6.4 Thermal Information

THERMAL METRIC ⁽¹⁾⁽²⁾⁽³⁾		TPS7H3301-SP	UNIT
		HKR (CFP)	
		16 PINS	
R _{θJA}	Junction-to-ambient thermal resistance	24.6	°C/W
R _{θJC(top)}	Junction-to-case (top) thermal resistance	5.8	°C/W
R _{θJB}	Junction-to-board thermal resistance	8.4	°C/W
ψ _{JT}	Junction-to-top characterization parameter	1.6	°C/W
ψ _{JB}	Junction-to-board characterization parameter	8.4	°C/W
R _{θJC(bot)}	Junction-to-case (bottom) thermal resistance	0.54	°C/W

- For more information about traditional and new thermal metrics, see the *Semiconductor and IC Package Thermal Metrics* application report, [SPRA953](#).
- Do not allow package body temperature to exceed 265°C at any time or permanent damage may result.
- Maximum power dissipation may be limited by overcurrent protection.

6.5 Electrical Characteristics

Over full temperature range, $T_J = -55^\circ\text{C}$ to 125°C , $V_{DD}/V_{IN} = 3.3\text{ V}$ and 2.375 V , $V_{LDOIN} = 1.8\text{ V}$, $V_{DDQSNS} = 1.8\text{ V}$, $V_{TTSNS} = 0.9\text{ V}$, $EN = V_{DD}/V_{IN}$, [Standard DDR Application](#) unless otherwise noted

All voltage values are with respect to the network ground (AGND) pin unless otherwise noted

PARAMETER		TEST CONDITIONS	MIN	TYP	MAX	UNIT
SUPPLY CURRENT						
$I_{V_{DD}/V_{IN}}$	Supply current	$EN = 3.3\text{ V}$, no load		18	30	mA
$I_{V_{DD}(SDN)}$	Shutdown current	$EN = 0\text{ V}$, $V_{DDQSNS} = 0$, no load		3	5	mA
		$EN = 0\text{ V}$, $V_{DDQSNS} > 0.78\text{ V}$, no load		6.5	8	
$I_{V_{LDOIN}}$	Supply current of VLDOIN	$EN = 3.3\text{ V}$, no load		575	1200	μA
$I_{V_{LDOIN}(SDN)}$	Shutdown current of VLDOIN	$EN = 0\text{ V}$, no load		50	100	μA
INPUT CURRENT						
$I_{V_{DDQSNS}}$	Input current, VDDQSNS	$EN = 3.3\text{ V}$		4	6	μA
V_{TT}/V_O OUTPUT						
VTTSENS	Output DC voltage, V_{TT}/V_O	$V_{LDOIN} = 2.5\text{ V}$, $V_{TTRF} = 1.25\text{ V}$ (DDR1), $I_{V_{TT}/V_O} = 0\text{ A}$	1.244	1.25	1.256	V
		$V_{LDOIN} = 1.8\text{ V}$, $V_{TTRF} = 0.9\text{ V}$ (DDR2), $I_{V_{TT}/V_O} = 0\text{ A}$	0.894	0.9	0.906	
		$V_{LDOIN} = 1.5\text{ V}$, $V_{TTRF} = 0.75\text{ V}$ (DDR3), $I_{V_{TT}/V_O} = 0\text{ A}$	0.744	0.75	0.756	
		$V_{LDOIN} = 1.35\text{ V}$, $V_{TTRF} = 0.675\text{ V}$ (DDR3L), $I_{V_{TT}/V_O} = 0\text{ A}$	0.669	0.675	0.681	
		$V_{LDOIN} = 1.2\text{ V}$, $V_{TTRF} = 0.6\text{ V}$ (DDR4), $I_{V_{TT}/V_O} = 0\text{ A}$	0.594	0.6	0.606	
$V_{LDOIN} - V_{TTSNS}^{(1)}$	$V_{LDOIN} > V_{TTSNS}$	$V_{DD}/V_{IN} = 2.95\text{ V}$, $V_{DDQSNS} = 2.5\text{ V}$, $V_{TTSNS} = V_{TTRF} - 50\text{ mV}$ (DDR1), $I_O = 0.5\text{ A}$		50	230	mV
		$V_{DD}/V_{IN} = 2.95\text{ V}$, $V_{DDQSNS} = 2.5\text{ V}$, $V_{TTSNS} = V_{TTRF} - 50\text{ mV}$ (DDR1), $I_O = 1\text{ A}$		101	300	
		$V_{DD}/V_{IN} = 2.95\text{ V}$, $V_{DDQSNS} = 2.5\text{ V}$, $V_{TTSNS} = V_{TTRF} - 50\text{ mV}$ (DDR1), $I_O = 2\text{ A}^{(2)}$		209	400	
		$V_{DD}/V_{IN} = 2.375\text{ V}$, $V_{DDQSNS} = 1.8\text{ V}$, $V_{TTSNS} = V_{TTRF} - 50\text{ mV}$ (DDR2), $I_O = 0.5\text{ A}^{(2)}$		54	230	
		$V_{DD}/V_{IN} = 2.375\text{ V}$, $V_{DDQSNS} = 1.8\text{ V}$, $V_{TTSNS} = V_{TTRF} - 50\text{ mV}$ (DDR2), $I_O = 1\text{ A}^{(2)}$		108	300	
		$V_{DD}/V_{IN} = 2.375\text{ V}$, $V_{DDQSNS} = 1.8\text{ V}$, $V_{TTSNS} = V_{TTRF} - 50\text{ mV}$ (DDR2), $I_O = 2\text{ A}^{(2)}$		228	400	
		$V_{DD}/V_{IN} = 2.375\text{ V}$, $V_{DDQSNS} = 1.5\text{ V}$, $V_{TTSNS} = V_{TTRF} - 50\text{ mV}$ (DDR3), $I_O = 0.5\text{ A}$		52	230	
		$V_{DD}/V_{IN} = 2.375\text{ V}$, $V_{DDQSNS} = 1.5\text{ V}$, $V_{TTSNS} = V_{TTRF} - 50\text{ mV}$ (DDR3), $I_O = 1\text{ A}$		104	300	
		$V_{DD}/V_{IN} = 2.375\text{ V}$, $V_{DDQSNS} = 1.5\text{ V}$, $V_{TTSNS} = V_{TTRF} - 50\text{ mV}$ (DDR3), $I_O = 2\text{ A}^{(2)}$		216	400	
		$V_{DD}/V_{IN} = 2.375\text{ V}$, $V_{DDQSNS} = 1.35\text{ V}$, $V_{TTSNS} = V_{TTRF} - 50\text{ mV}$ (DDR3L), $I_O = 0.5\text{ A}$		50	230	
		$V_{DD}/V_{IN} = 2.375\text{ V}$, $V_{DDQSNS} = 1.35\text{ V}$, $V_{TTSNS} = V_{TTRF} - 50\text{ mV}$ (DDR3L), $I_O = 1\text{ A}$		102	300	
		$V_{DD}/V_{IN} = 2.375\text{ V}$, $V_{DDQSNS} = 1.35\text{ V}$, $V_{TTSNS} = V_{TTRF} - 50\text{ mV}$ (DDR3L), $I_O = 2\text{ A}^{(2)}$		212	400	
		$V_{DD}/V_{IN} = 2.375\text{ V}$, $V_{DDQSNS} = 1.2\text{ V}$, $V_{TTSNS} = V_{TTRF} - 50\text{ mV}$ (DDR4), $I_O = 0.5\text{ A}$		50	230	
		$V_{DD}/V_{IN} = 2.375\text{ V}$, $V_{DDQSNS} = 1.2\text{ V}$, $V_{TTSNS} = V_{TTRF} - 50\text{ mV}$ (DDR4), $I_O = 1\text{ A}$		102	300	
		$V_{DD}/V_{IN} = 2.375\text{ V}$, $V_{DDQSNS} = 1.2\text{ V}$, $V_{TTSNS} = V_{TTRF} - 50\text{ mV}$ (DDR4), $I_O = 2\text{ A}^{(2)}$		210	400	
$V_{TTSNS}/V_{O(TOL)}$	Output voltage tolerance to VTTREF	$I_{V_{TTSNS}/V_O} = -3\text{ A}$, across V_{DD}/V_{IN} voltage range ⁽²⁾	12	25	34	mV
		$I_{V_{TTSNS}/V_O} = 3\text{ A}$, across V_{DD}/V_{IN} voltage range ⁽²⁾	-34	-25	-12	
$I_{V_{OSRCL}}$	V_{TTSNS}/V_O source current limit	With reference to VTTREF, $V_{TTSNS} = 90\% \times V_{TTRF}$	3.25		8	A
$I_{V_{OSNCL}}$	V_{TTSNS}/V_O sink current limit	With reference to VTTREF, $V_{TTSNS} = 110\% \times V_{TTRF}$	3.5		5.5	A
R_{DSCHRG}	Discharge impedance	$V_{DDQSNS} = 0\text{ V}$, $V_{TTSNS}/V_O = 0.3\text{ V}$, $EN = 0\text{ V}$, $T_A = 25^\circ\text{C}$		18	25	Ω
POWER-GOOD COMPARATOR						

(1) Dropout and headroom information provided to help designer in optimizing system efficiency.

(2) Specified by characterization and not production tested.

Electrical Characteristics (continued)

Over full temperature range, $T_J = -55^\circ\text{C}$ to 125°C , $V_{DD}/V_{IN} = 3.3\text{ V}$ and 2.375 V , $V_{LDOIN} = 1.8\text{ V}$, $V_{DDQSNS} = 1.8\text{ V}$, $V_{TTSNS} = 0.9\text{ V}$, $EN = V_{DD}/V_{IN}$, *Standard DDR Application* unless otherwise noted

All voltage values are with respect to the network ground (AGND) pin unless otherwise noted

PARAMETER		TEST CONDITIONS	MIN	TYP	MAX	UNIT
$V_{TH(PG)}$	VTT/VO PGOOD threshold	PGOOD window lower threshold with respect to V_{VTTREF}	-23.5%	-20%	-17.5%	
		PGOOD window upper threshold with respect to V_{VTTREF}	17.5%	20%	23.5%	
		PGOOD hysteresis		5%		
$T_{PGSTUPDLY}$	PGOOD startup delay	Startup rising edge, VTTSENS within 15% of V_{VTTREF}		2		ms
$V_{PGOODLOW}$	Output low voltage	$I_{SINK} = 4\text{ mA}$			0.4	V
$T_{PBADDLY}$	PGOOD bad delay	VTTSENS is outside of the $\pm 20\%$ PGOOD window		1		μs
$I_{PGOODLK}$	Leakage current	VTTSENS = VTTREF (PGOOD high impedance), PGOOD = $V_{DD}/V_{IN} + 0.2\text{ V}$			1	μA
VDDQSNS AND VTTREF OUTPUT						
VDDQSNS	VDDQSNS voltage range		1		2.8	V
$V_{VDDQSNS_UVLO}$	VDDQSNS undervoltage lockout	V_{DDQSNS} rising		780		mV
$V_{VDDQSNSUVHYS}$	VDDQSNS undervoltage lockout hysteresis			20		mV
V_{VTTREF}	VTTREF voltage			$V_{DDQSNS} / 2$		V
V_{VTTREF}	VTTREF voltage tolerance to VDDQSNS	$-10\text{ mA} < I_{VTTREF} < 10\text{ mA}$, $V_{DDQSNS} = 2.5\text{ V}$	-15		15	mV
		$-10\text{ mA} < I_{VTTREF} < 10\text{ mA}$, $V_{DDQSNS} = 1.8\text{ V}$	-15		15	
		$-10\text{ mA} < I_{VTTREF} < 10\text{ mA}$, $V_{DDQSNS} = 1.5\text{ V}$	-15		15	
		$-10\text{ mA} < I_{VTTREF} < 10\text{ mA}$, $V_{DDQSNS} = 1.35\text{ V}$	-15		15	
		$-10\text{ mA} < I_{VTTREF} < 10\text{ mA}$, $V_{DDQSNS} = 1.2\text{ V}$	-15		15	
$I_{VTTREFSRCL}$	V_{VTTREF} source current limit	VTTREF = 0 V	10	40		mA
$I_{VTTREFSNCL}$	V_{VTTREF} sink current limit	VTTREF = 0 V	6	40		mA
$I_{VTTREFDIS}$	VTTREF discharge current	EN = 0 V, $V_{DDQSNS} = 0\text{ V}$, VTTREF = 0.5 V		1.3		mA
UVLO/EN LOGIC THRESHOLD						
$V_{VINUVVIN}$	UVLO threshold	Wakeup, $T_A = 25^\circ\text{C}$		2.18	2.25	V
$V_{VINUVVINHYS}$	UVLO threshold hysteresis	Hysteresis		50		mV
V_{ENIH}	High-level input voltage	Enable	1.7			V
V_{ENIL}	Low-level input voltage	Enable			0.3	V
V_{ENYST}	Hysteresis voltage	Enable		0.5		V
I_{ENLEAK}	Logic input leakage current	EN, $T_A = 25^\circ\text{C}$	-1		1	μA
THERMAL SHUTDOWN						
T_{SON}	Thermal shutdown threshold ⁽³⁾	Shutdown temperature		210		$^\circ\text{C}$
		Hysteresis		12		

(3) Ensured by design, not production tested.

6.6 Typical Characteristics

For Figure 1 through Figure 10, (3 × 150-μF T530D157M010ATE005 tantalum + 4 × 4.7-μF MLCC) or equivalent capacitance/ESR are used on VTT output

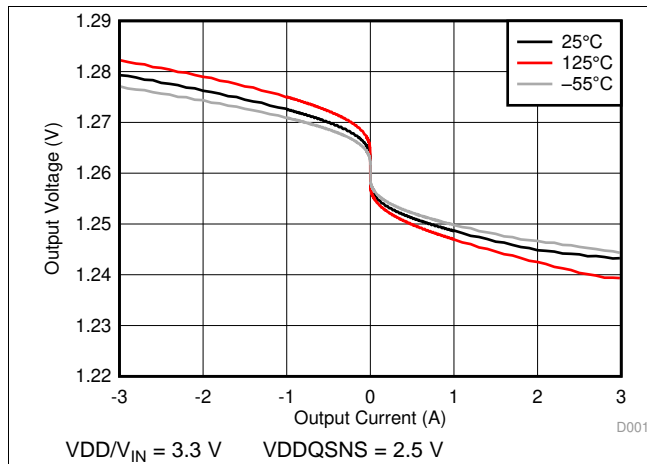

Figure 1. Output Voltage vs Output Current

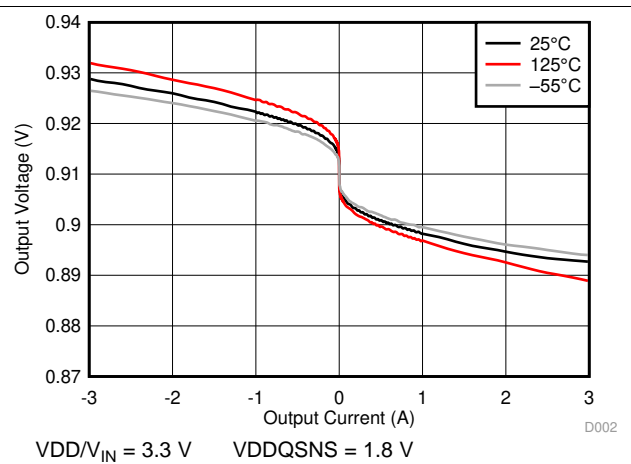

Figure 2. Output Voltage vs Output Current

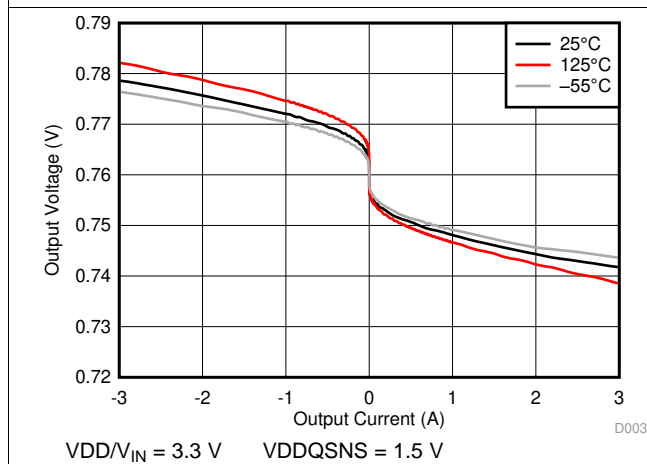

Figure 3. Output Voltage vs Output Current

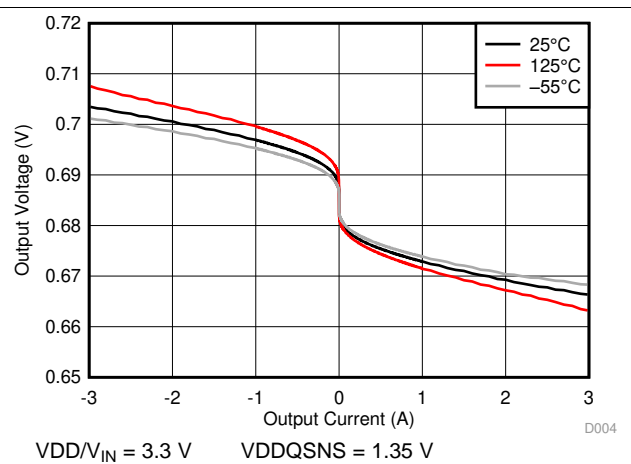

Figure 4. Output Voltage vs Output Current

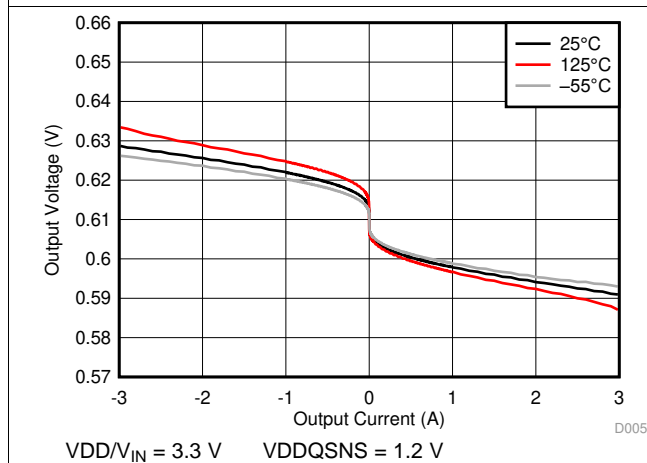

Figure 5. Output Voltage vs Output Current

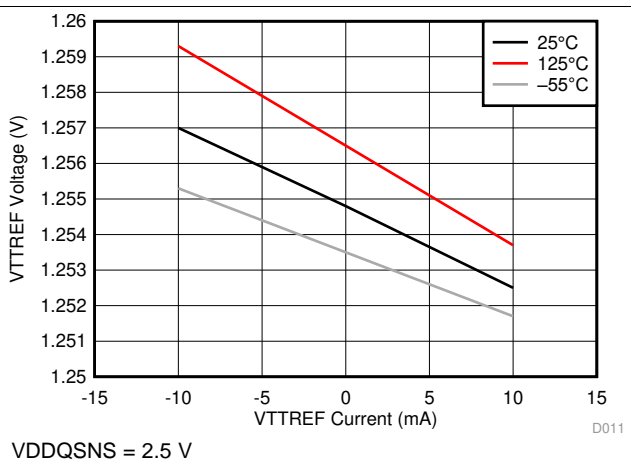

Figure 6. VTTREF Voltage vs VTTREF Current

Typical Characteristics (continued)

For Figure 1 through Figure 10, (3 × 150-μF T530D157M010ATE005 tantalum + 4 × 4.7-μF MLCC) or equivalent capacitance/ESR are used on VTT output

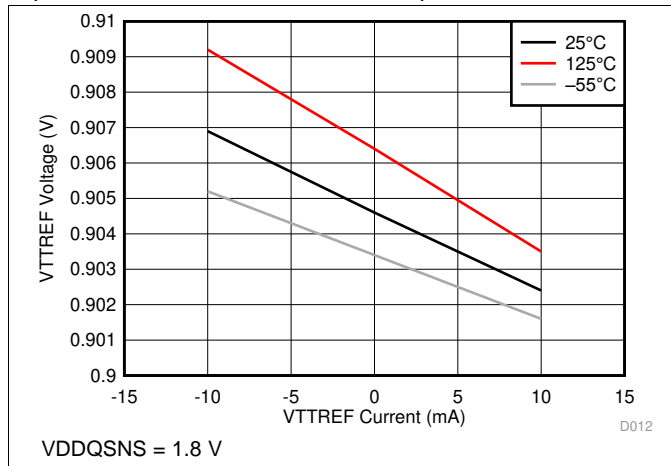

Figure 7. VTTREF Voltage vs VTTREF Current

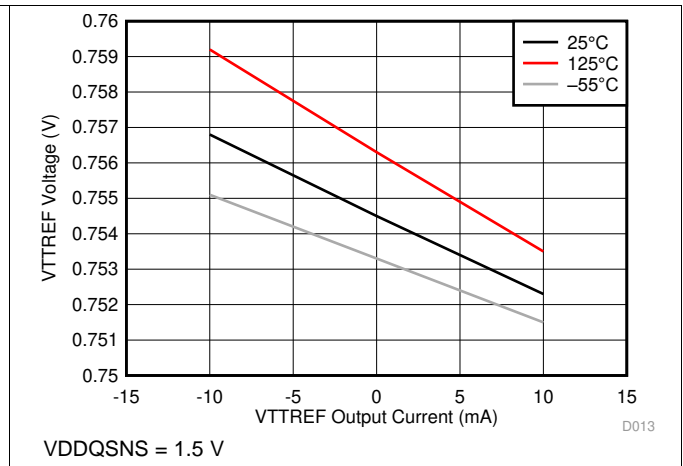

Figure 8. VTTREF Voltage vs VTTREF Current

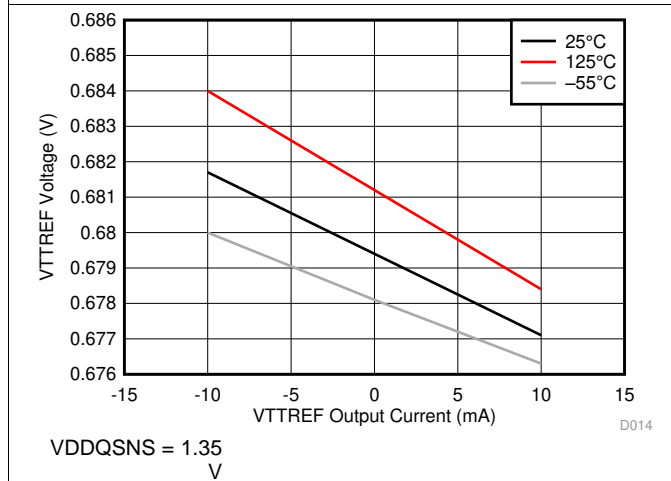

Figure 9. VTTREF Voltage vs VTTREF Current

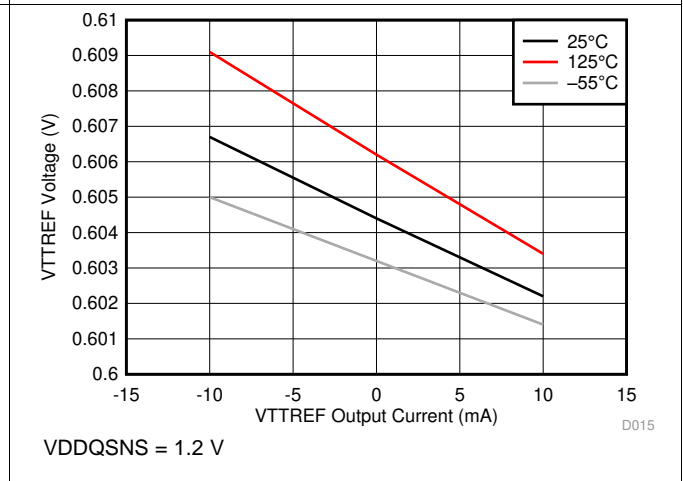

Figure 10. VTTREF Voltage vs VTTREF Current

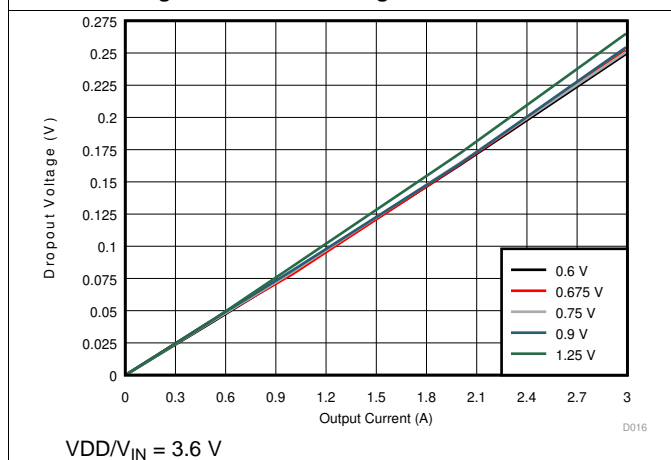

Figure 11. Dropout Voltage vs Output Current

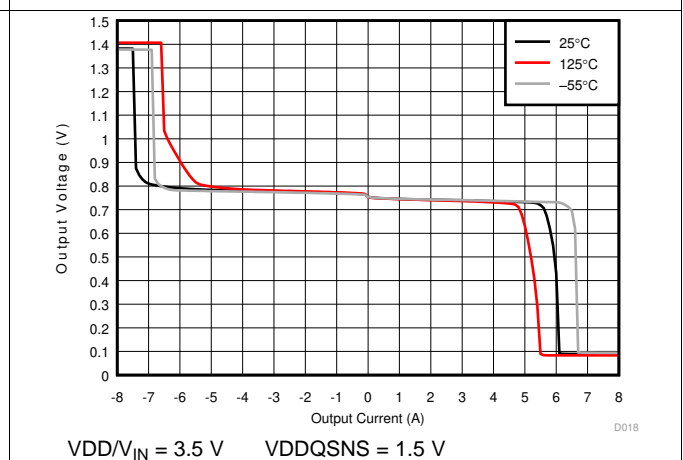
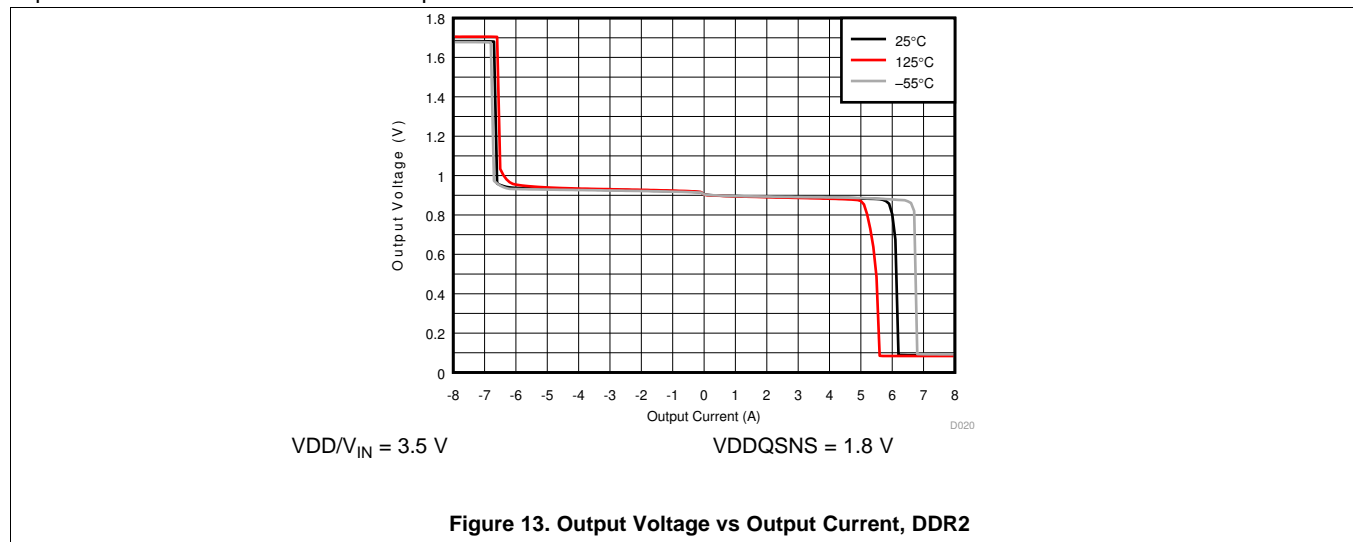

Figure 12. Output Voltage vs Output Current, DDR3

Typical Characteristics (continued)

For [Figure 1](#) through [Figure 10](#), (3 × 150-μF T530D157M010ATE005 tantalum + 4 × 4.7-μF MLCC) or equivalent capacitance/ESR are used on VTT output



7 Detailed Description

7.1 Overview

The TPS7H3301-SP device is a sink and source double data rate (DDR) termination regulator specifically designed for low input voltage, low-noise systems where space and weight is a key consideration.

7.2 Functional Block Diagram

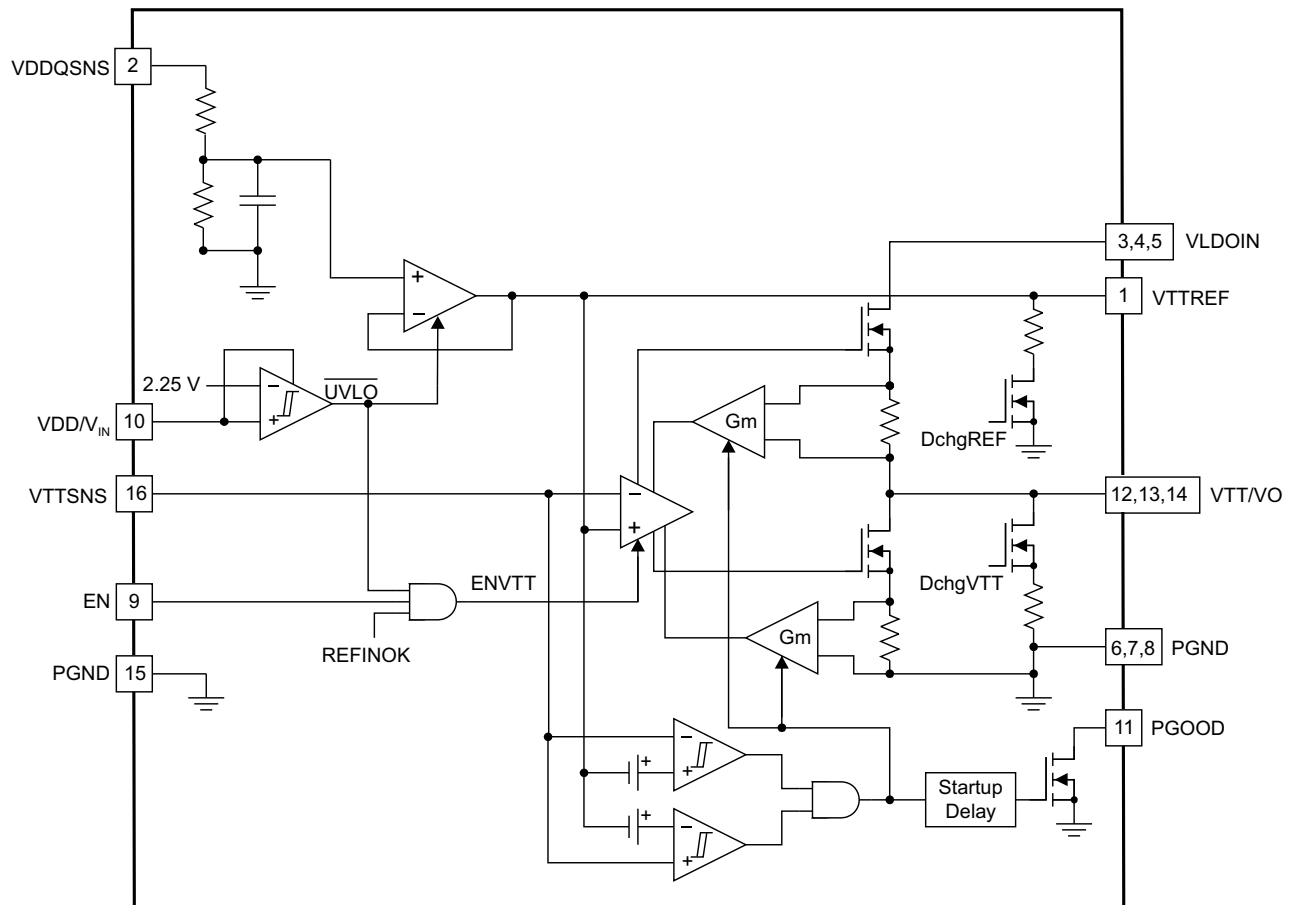

7.3 Feature Description

7.3.1 VTT/V_O Sink and Source Regulator

The TPS7H3301-SP is a 3-A sink and source tracking termination regulator specifically designed for low input voltage, and low external component count systems where space is a key application parameter. The TPS7H3301-SP integrates a high-performance, low-dropout (LDO) linear regulator that is capable of both sinking and sourcing current. The LDO regulator employs a fast feedback loop so that ceramic capacitors can be used to support the fast load transient response. To achieve tight regulation with minimum effect of trace resistance, a remote sensing pin (VTTSENS) should be connected to the positive pin of the output capacitor(s) as a separate trace from the high-current path of VTT/V_O.

The TPS7H3301-SP has a dedicated pin (VLDOIN) for VTT power supply to minimize the LDO power dissipation on user application. The minimum VLDOIN voltage is 400 mV above the 1/2 VDDQSN voltage or as highlighted in [Electrical Characteristics](#) (VLDOIN to VTT headroom) for various load conditions.

Feature Description (continued)

7.3.2 Reference Input (VDDQSNS)

The output voltage, V_{TT}/V_O , is regulated to V_{TTREF} . V_{DDQSNS} incorporates an integrated resistor divider network. V_{DDQSNS} should be connected to the memory supply bus (V_{DDQ}). The TPS7H3301-SP supports V_{DDQSNS} voltage from 1 V to 3.5 V, making it versatile and ideal for many types of low-power LDO applications.

7.3.3 Reference Output (VTTREF)

When it is configured for DDR termination applications, V_{TTREF} buffers the DDR V_{TT} reference voltage for the memory application. The V_{TTREF} block consists of an on-chip 1/2 resistor divider and a low-pass filter (LPF). V_{TTREF} tracks 1/2 of V_{DDQSNS} within 15 mV. It is capable of supporting both a sourcing and sinking load of 10 mA. V_{TTREF} becomes active when V_{DDQSNS} voltage rises to 0.78 V and V_{DD}/V_{IN} is above the UVLO threshold. When V_{TTREF} is less than 0.76 V, V_{TTREF} is disabled and subsequently discharges to GND through an internal MOSFET. V_{TT}/V_O is also discharged following the discharge of V_{TTREF} . V_{TTREF} is independent of the EN pin state. To meet stability criteria, a ceramic capacitor of 0.1- μ F minimum must be installed close to V_{TTREF} (pin1). Capacitor value at V_{TTREF} (pin 1) must not exceed 2.2 μ F.

7.3.4 EN Control (EN)

When EN is driven high, the TPS7H3301-SP V_{TT}/V_O regulator begins normal operation. When EN is driven low, V_{TT}/V_O discharges to GND through an internal 18- Ω MOSFET. V_{TTREF} remains on when EN is driven low. EN is not tied high internally to prevent power sequencing issues with an external signal that may be controlling the enable. EN is a floating input and not internally tied, thus the user can have complete control over where and when the EN signal is generated. EN feeds directly into power-good (PGOOD). When enable is low, PGOOD is low.

7.3.5 Power-Good Function (PGOOD)

The TPS7H3301-SP provides an open-drain PGOOD output that goes high when the V_{TT}/V_O output is within 20% of V_{TTREF} (typ). PGOOD deasserts within 1 μ s after the output exceeds the size of the power-good window. During initial V_{TT}/V_O startup, PGOOD asserts high 2 ms (typ) after the V_{TT}/V_O enters power-good window. Because PGOOD is an open-drain output, a 100-k Ω pullup resistor between PGOOD and a stable active supply voltage rail is required.

7.3.6 V_{TT} Current Protection

The LDO has a constant overcurrent limit (OCL). See [Figure 13](#) for typical behavior across temperature.

7.3.7 V_{IN} UVLO Protection

For V_{DD}/V_{IN} undervoltage lockout (UVLO) protection, the TPS7H3301-SP monitors V_{DD}/V_{IN} voltage. When the V_{DD}/V_{IN} voltage is lower than the UVLO threshold voltage, both the V_{TT} and V_{TTREF} regulators are powered off. This shutdown is a non-latch protection.

7.3.8 Thermal Shutdown

The TPS7H3301-SP monitors its junction temperature. If the device junction temperature exceeds its threshold value, (typically 210°C), the V_{TT}/V_O and V_{TTREF} regulators are both shutoff and discharged by the internal discharge MOSFETs. This shutdown is a non-latch protection.

7.4 Device Functional Modes

The TPS7H3301-SP 3-A sink and source LDO provides low output noise to meet system needs. In order to improve efficiency in the LDO, TPS7H3301-SP LDO can operate from low VLDOIN voltage rail, thus using dual voltage source one for the VLDOIN that supports high-current and an alternate voltage source that provides voltage for VDDQSNS pin.

In some cases VLDOIN and VDDQSNS pins are tied together. In the memory system, VDDQ is a high-current supply that powers the core, the I/O, and the logic of the memory. VTTREF is a low-current, precision reference voltage that provides a threshold between a logic high (one) and a logic low (zero) that adapts to changes in the I/O supply voltage. By providing a precision threshold that adapts to the supply voltage, VTTREF realizes wider noise margins than those possible with a fixed threshold and normal variations in termination and drive impedance. Specifications vary for different DDR technologies. For example DDR3 JEDEC JESD79-3F specifies 0.49 to 0.51 times VDDQ and draws only tens to hundreds of microamps. The TPS7H3301-SP VTTREF is designed to sink and source up to 10 mA.

8 Application and Implementation

NOTE

Information in the following applications sections is not part of the TI component specification, and TI does not warrant its accuracy or completeness. TI's customers are responsible for determining suitability of components for their purposes. Customers should validate and test their design implementation to confirm system functionality.

8.1 Application Information

The TPS7H3301-SP device is a highly-integrated sink and source LDO. The device is targeted to support VTT voltage for DDR memory applications and is capable of sourcing and sinking 3-A load current. The TPS7H3301-SP user's guide is available on www.ti.com, [SLVUAK2](#). The guide highlights standard EVM test results, schematic, and bill of materials (BOM) for reference.

8.2 Typical Application

The design example describes a 2.5-V V_{IN} , DDR3 configuration.

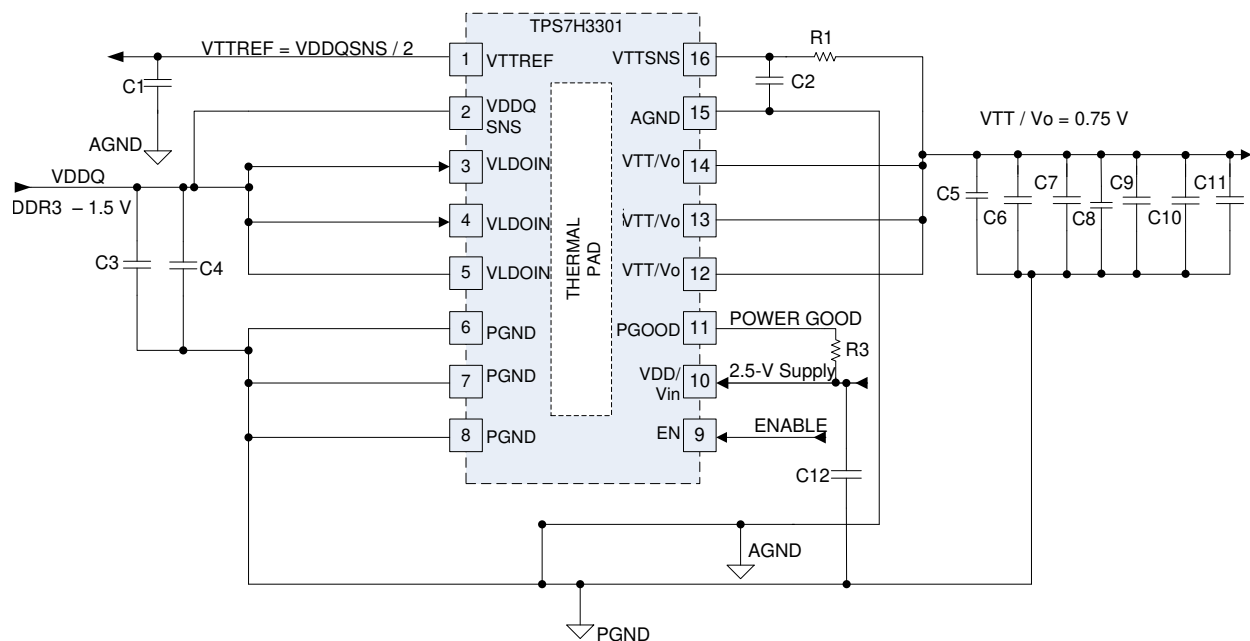

Figure 14. Typical Application Circuit

8.2.1 Design Requirements

See the [Recommended Operating Conditions](#) for recommended limits.

Typical Application (continued)

8.2.2 Detailed Design Procedure

Table 1. Design Example 1 List of Materials

REFERENCE DESIGNATOR	DESCRIPTION	SPECIFICATION	PART NUMBER	MANUFACTURER
R1	Resistor	392 Ω	CRCW0603392RFKEA	
R3		100 k Ω	CRCW0603100KJNEA	
C3, C5, C6, C7	Capacitor	150 μ F, 10 V	T530D157M010ATE005	Kemet
C2		1000 pF	GRM188R71H102KA01D	MuRata
C1		0.1 μ F	08053C104KAT2A	AVX
C4, C8, C9, C10, C11		4.7 μ F, 10 V	1210ZC475KAT2A	Murata
C12		10 μ F, 10 V	GRM21BR71A106KE51L	Murata

8.2.2.1 VDD/V_{IN} Capacitor

Add a ceramic capacitor, with a value between 1- and 10- μ F, placed close to the VDD/V_{IN} pin to minimize high frequency noise from the supply.

8.2.2.2 VLDO Input Capacitor

Depending on the trace impedance between the VLDOIN/VDDQ bulk power supply to the device, a transient increase of source current is supplied mostly by the charge from the VLDOIN/VDDQ input capacitor. Use a 150- μ F (or greater) tantalum capacitor in parallel with a 4.7- μ F ceramic capacitor to supply this transient charge. Provide more input capacitance as more output capacitance is used at VTT/V_O.

8.2.2.3 VTT Output Capacitor

For stable operation, the total capacitance of the VTT/V_O output pin must be greater than 470 μ F. Attach three, 3 \times 150- μ F low-ESR tantalum capacitors in parallel with ceramic capacitors to minimize the effect of equivalent series resistance (ESR) and equivalent series inductance (ESL). If the total parallel ESR is greater than 2 m Ω , insert an R-C filter between the output and the VTTSNS input to achieve loop stability. The R-C filter time constant should be almost the same as or slightly lower than the time constant of the output capacitor and its ESR.

8.2.2.4 VTTSNS Connection

To achieve tight regulation with minimum effect of trace resistance, a remote sensing pin (VTTSNS) should be connected to the positive pin of the VTT pin output capacitor or capacitors as a separate trace from the high-current path from VTT. Consider adding a low-pass R-C filter at the VTTSNS pin in case the ESR of the VTT output capacitor or capacitors is larger than 2 m Ω . The R-C filter time constant should be approximately the same or slightly lower than the time constant of the VTT output capacitance and ESR.

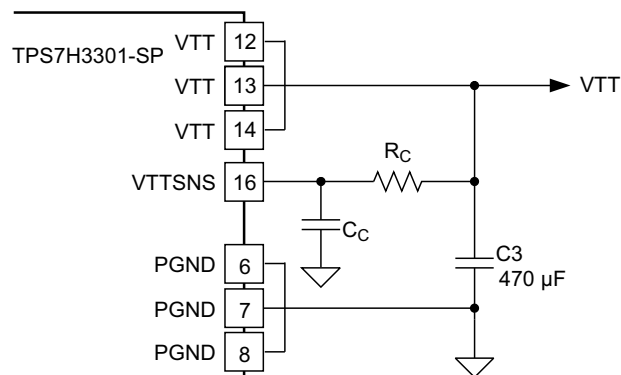
Figure 15. R-C Filter for VTTSNS

8.2.2.5 Low V_{IN} Applications

TPS7H3301-SP can be used in an application system where either a 2.5-V rail or a 3.3-V rail is available. The TPS7H3301-SP minimum input voltage requirement is 2.375 V. If a 2.5-V rail is used, ensure that the absolute minimum voltage (both DC and transient) at the device pin is 2.375 V or greater. The voltage tolerance for a 2.5-V rail input is between –5% and 5% accuracy, or better.

8.2.2.6 S3 and Pseudo-S5 Support

The TPS7H3301-SP provides S3 support by an EN function. The EN pin could be connected to an SLP_S3 signal in the end application. Both VTTREF and VTT/V_O are on when EN = high (S0 state). VTTREF is maintained while VTT/V_O is turned off and discharged via an internal discharge MOSFET when EN = low (S3 state). Please notice that the EN signal controls only the output buffer for VTT/V_O and therefore, while in S3 state, VDDQSNS is present in order to maintain data in volatile memory. As a result, when EN is set high to exit the S3 state, it is desired to bring V_O/VTT into regulation as fast as possible. This causes an output current controlled by the current limit of the device and the output capacitors.

When EN = low and the VDDQSNS voltage is less than 0.78 V, TPS7H3301-SP enters pseudo-S5 state. Both VTT/V_O and VTTREF outputs are turned off and discharged to GND through internal MOSFETs when pseudo-S5 support is engaged (S4/S5 state). [Figure 16](#) shows a typical startup and shutdown timing diagram for an application that uses S3 and pseudo-S5 support.

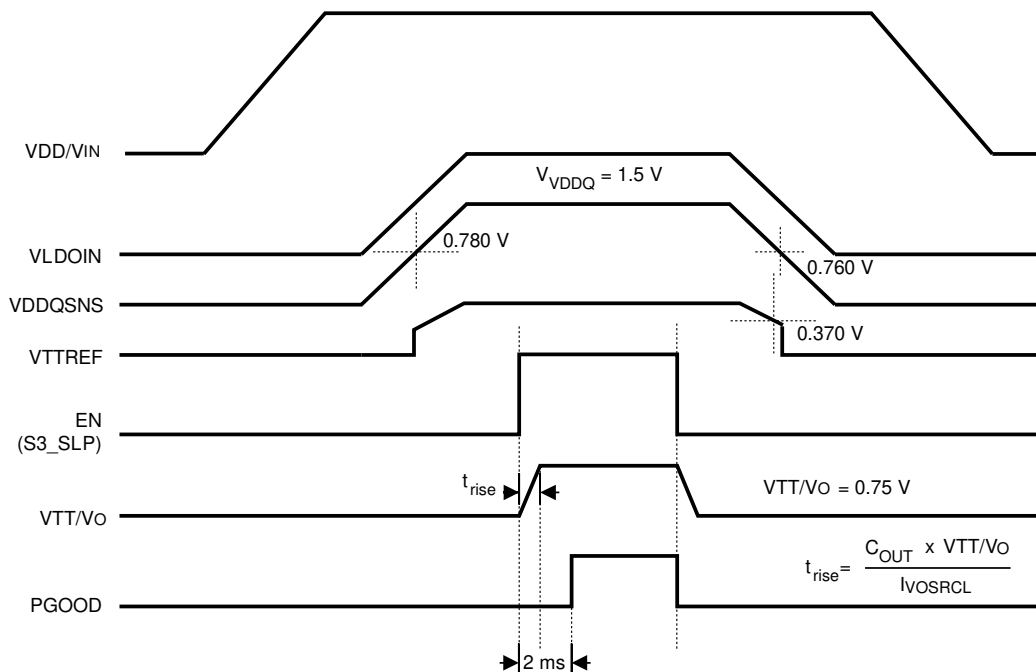

Figure 16. Typical Timing Diagram for S3 and Pseudo-S5 Support

8.2.2.7 Tracking Startup and Shutdown

The TPS7H3301-SP supports tracking startup of VDDQ and shutdown when EN is tied directly to the system bus and not used to turn on or turn off the device. During tracking startup, VTT/V_O follows VTTREF once VDDQSNS voltage is greater than 0.78 V. VDDQSNS incorporates a resistor divider network and a time constant of about 445 μ s. The rise time of the VTT/V_O output is then a function of the rise time of VDDQSNS. If the VDDQSNS rise time is larger than 445 μ s, PGOOD is asserted 2 ms after VTT/V_O is within \pm 20% of VTTREF. During tracking shutdown, VTT/V_O falls following VTTREF until VTTREF reaches 0.37 V. Once VTTREF falls below 0.37 V, the internal discharge MOSFETs are turned on and quickly discharge both VTTREF and VTT/V_O to GND. PGOOD is deasserted once VTT/V_O is beyond the \pm 20% range of VTTREF. [Figure 17](#) shows the typical timing diagram for an application that uses tracking startup and shutdown.

There are no sequencing requirements between VDD/V_{IN} and VLDOIN. If VLDOIN is applied first followed by VDD/V_{IN} there is no issue. VDD/V_{IN} UVLO protection monitors VDD/V_{IN} voltage. When VDD/V_{IN} is lower than UVLO threshold both VTT and VTTREF regulators are powered off.

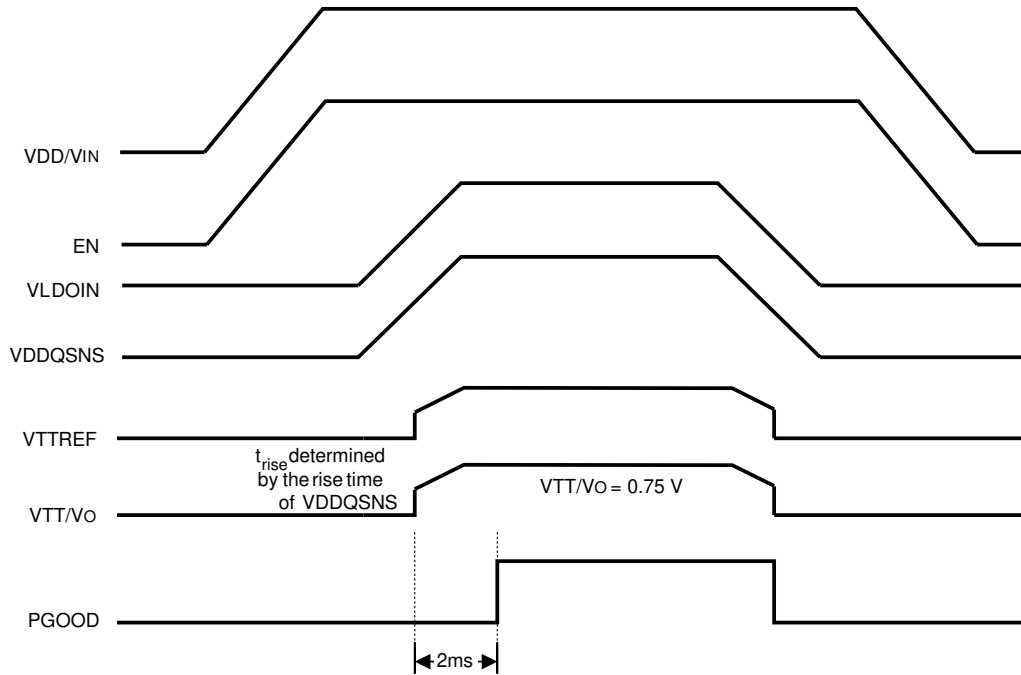

Figure 17. Typical Timing Diagram of Tracking Startup and Shutdown

8.2.2.8 Output Tolerance Consideration for VTT DIMM or Module Applications

The TPS7H3301-SP is specifically designed to power up the memory termination rail (as shown in Figure 18). The DDR memory termination structure determines the main characteristics of the VTT rail, which is to be able to sink and source current while maintaining acceptable VTT tolerance. See Figure 19 for typical characteristics for a single memory cell.

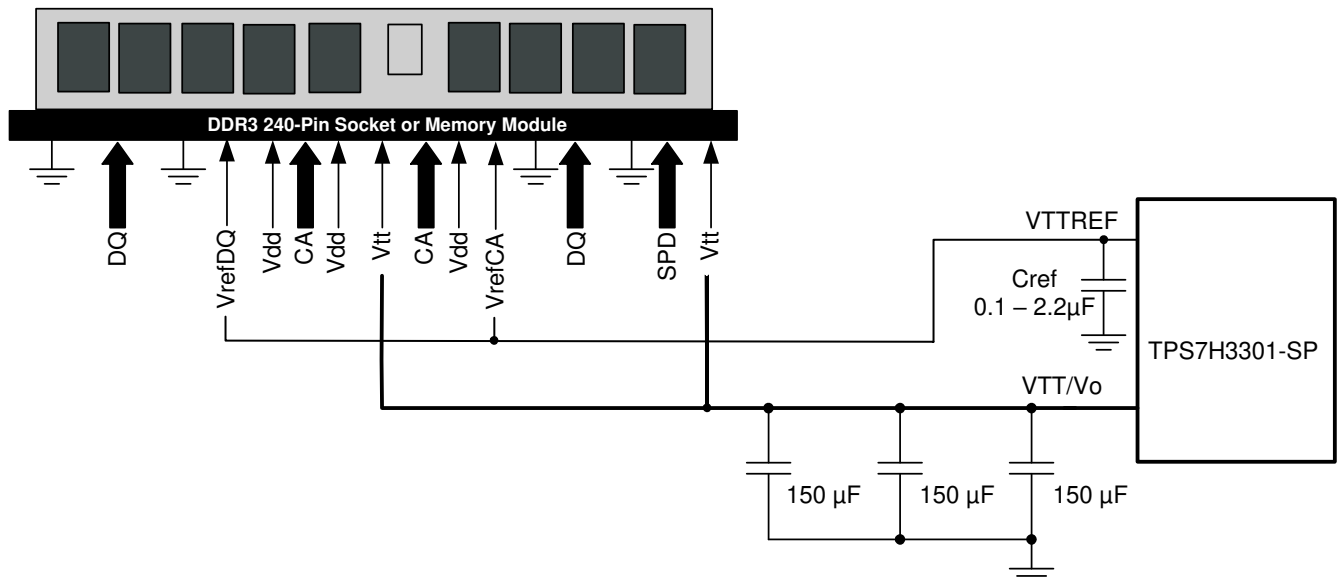

Figure 18. Typical Application Diagram for DDR3 VTT DIMM/Module Using TPS7H3301-SP

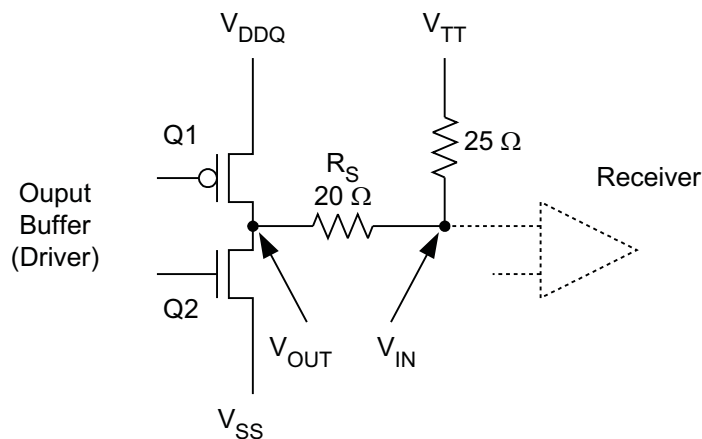

Figure 19. DDR Physical Signal System SSTL Signaling

In [Figure 19](#), when Q1 is on and Q2 is off:

- Current flows from VDDQ via the termination resistor to VTT.
- VTT sinks current.

In [Figure 19](#), when Q2 is on and Q1 is off:

- Current flows from VTT via the termination resistor to GND.
- VTT sources current.

Because VTT accuracy has a direct impact on the memory signal integrity, it is imperative to understand the tolerance requirement on VTT. Based on JEDEC VTT specifications for DDR and DDR2. See [Table 2](#) for detailed information and JEDEC relevant specifications.

$$V_{TTREF} - 40 \text{ mV} < V_{TT} < V_{TTREF} + 40 \text{ mV}, \text{ for both DC and AC conditions}$$

The specification itself indicates that VTT must keep track of VTTREF for proper signal conditioning.

The TPS7H3301-SP ensures the regulator output voltage to be:

$$V_{TTREF} - 34 \text{ mV} < V_{TT} < V_{TTREF} + 34 \text{ mV}, \text{ for both DC and AC conditions and } -3 \text{ A} < I_{V_{TT}} < 3 \text{ A}$$

The regulator output voltage is measured at the regulator side, not the load side. The tolerance is applicable to DDR, DDR2, DDR3 and low-power DDR3/DDR4 applications (see [Table 2](#) for detailed information). To meet the stability requirement, a minimum output capacitance of 470 μF is needed, combination of both tantalum and ceramic capacitors. Considering the actual tolerance on the MLCC capacitors, four or higher 4.7- μF ceramic capacitors in parallel with 3 \times 150- μF low-ESR tantalum capacitor are sufficient to meet the above requirement. Higher ESR tantalum capacitors will require multiple tantalum capacitors in parallel with ceramic capacitors to meet system needs.

Table 2. DDR, DDR2, DDR3, and LP DDR3 Termination Technology and Differences

	DDR	DDR2	DDR3	LOW POWER DDR3 (DDR3L)
FSB data rates	200, 266, 333 and 400 MHz	400, 533, 677 and 800 MHz	800, 1066, 1330 and 1600 MHz	Same as DDR3
Termination	Motherboard termination to VTT for all signals	On-die termination for data group. VTT/V _O used for termination of address, command and control signals.	On-die termination for data group. VTT/V _O used for termination of address, command and control signals.	Same as DDR3
Termination current demand	Max sink and source transient currents of up to 2.6 A to 2.9 A	Not as demanding <ul style="list-style-type: none"> Only 34 signals (address, command, control) tied to VTT/V_O ODT handles data signals Less than 1 A of burst current 	Not as demanding <ul style="list-style-type: none"> Only 34 signals (address, command, control) tied to VTT/V_O ODT handles data signals Less than 1 A of burst current 	Same as DDR3
Voltage level	2.5-V core and I/O 1.25-V VTT	1.8-V core and I/O 0.9-V VTT	1.5-V core and I/O 0.75-V VTT	1.35-V core and I/O 0.68-V VTT
Relevant JEDEC specification	JESD79F (SSTL_2 JESD8-9B)	DDR2 JESD79-2F (SSTL_18 JESD8-15)	DDR3 JESD79-3F	DDR3L JESD79-3-1A.01

The TPS7H3301-SP is designed as a G_m-driven LDO. The voltage droop between the reference input and the output regulator is determined by the transconductance and output current of the device. The typical G_m is 250 S at 3 A and changes with respect to the load in order to conserve the quiescent current (that is, the G_m is very low at no load condition). The G_m LDO regulator is a single pole system. Its unity gain bandwidth for the voltage loop is only determined by the output capacitance, as a result of the bandwidth nature of the G_m (see [Equation 1](#)).

$$F_{UGBW} = \frac{G_m}{2 \times \pi \times C_{OUT}}$$

where

- F_{UGBW} is the unity gain bandwidth
- G_m is transconductance
- C_{OUT} is the output capacitance

(1)

There are two limitations to this type of regulator when it comes to the output bulk capacitor requirement. To maintain stability, the zero location contributed by the ESR of the output capacitors should be greater than the –3-dB point of the current loop. This constraint means that higher ESR capacitors should not be used in the design. In addition, the impedance characteristics of the ceramic capacitor should be well understood in order to prevent the gain peaking effect around the G_m –3-dB point because of the large ESL, the output capacitor, and parasitic inductance of the VTT/V_O trace.

[Figure 20](#) shows the bode plot simulation for a typical DDR3 configuration of the TPS7H3301-SP, where:

- VDD/V_{IN} = 2.4 V
- V_{VLD0IN} = 1.5 V
- VTT/V_O = 0.75 V
- I_{IO} = 2 A
- 3 × 150-μF low-ESR tantalum capacitors (T530D157M010ATE005) in parallel with 4 × 4.7-μF ceramic capacitor
- ESR = 1.66 mΩ
- ESL = 800 pH

The unity-gain bandwidth is approximately 87.3 kHz and the phase margin is 82°. The 0-dB level is crossed, the gain peaks because of the ESL effect. However, the peaking is kept well below 0 dB.

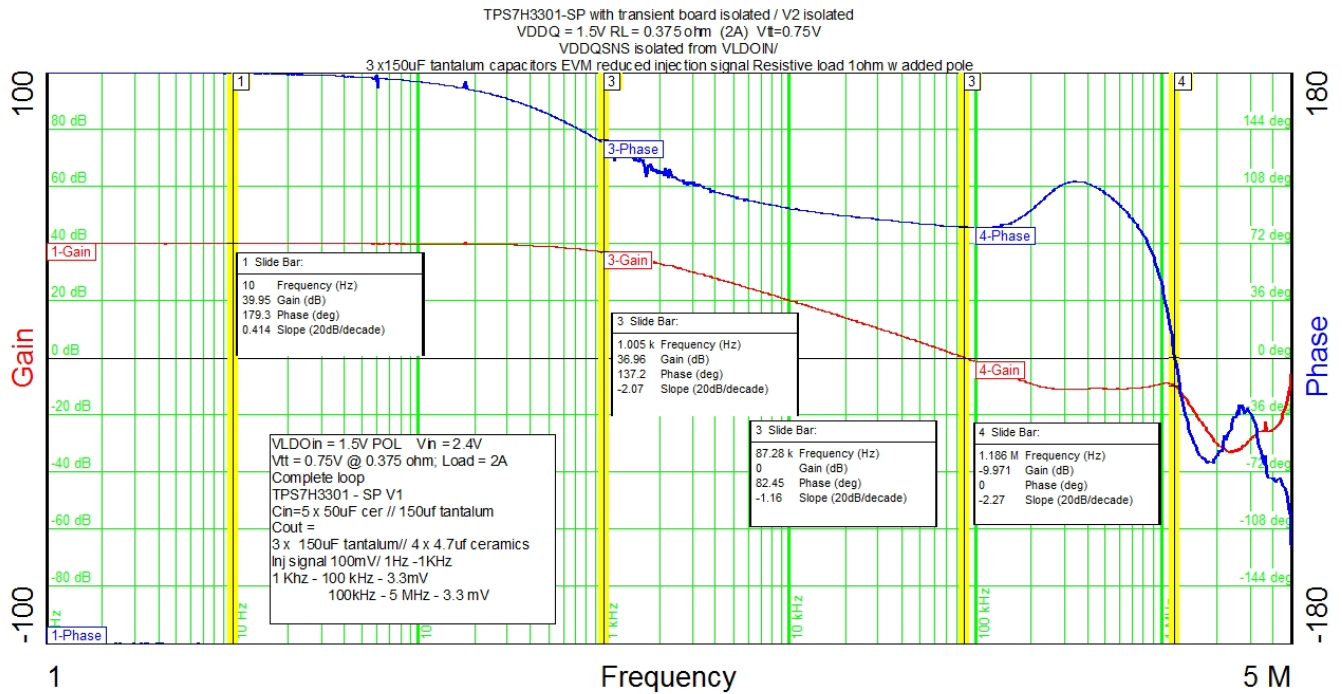

Figure 20. Bode Plot for a Typical DDR3 Configuration

Figure 3 shows the load regulation and Figure 21 shows the transient response for a typical DDR3 configuration. When the regulator is subjected to worst case ± 3 -A load step. The current shown only represents the device sourcing 3 A due to location of current probe.

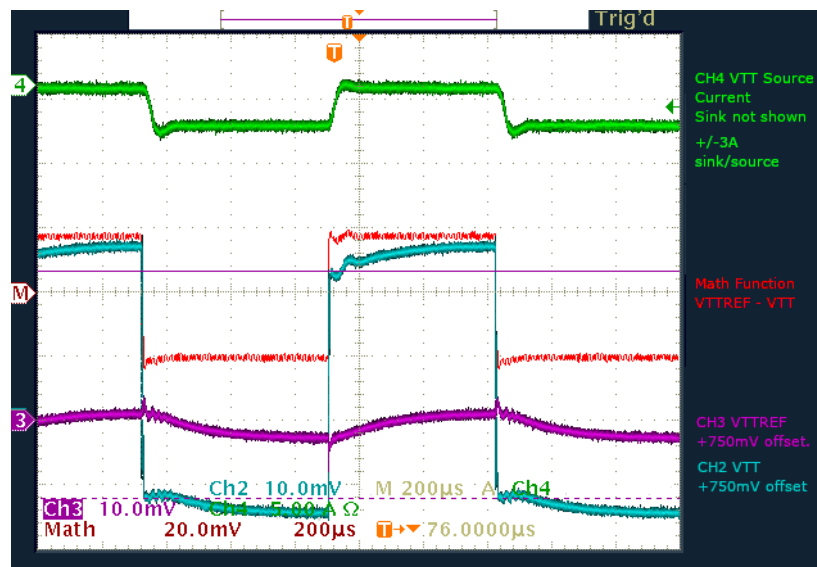

Figure 21. Transient Plot

8.2.2.9 LDO Design Guidelines

The minimum input (VLDOIN) to output voltage (VTT/V_O) difference (headroom) decides the lowest usable supply voltage Gm-driven to drive a certain load. For TPS7H3301-SP, a minimum of 300 mV (VLDOIN_{MIN} – VTT/V_{OMAX}) is needed in order to support a Gm driven sourcing current of 3 A based on a design of VLDOIN = 3.3 V and C_{OUT} = 470 μF. Because the TPS7H3301-SP is essentially a Gm-driven LDO, its impedance characteristics are both a function of the 1/Gm and R_{DS(on)} of the sourcing MOSFET (see Figure 22). The current inflection point of the design is between 3 A and 4 A. When I_{SRC} is less than the inflection point, the LDO is considered to be operating in the Gm region; when I_{SRC} is greater than the inflection point but less than the overcurrent limit point, the LDO is operating in the R_{DS(on)} region. The typical sourcing R_{DS(on)} is 154 mΩ with V_{IN} = 3 V and T_J = 125°C.

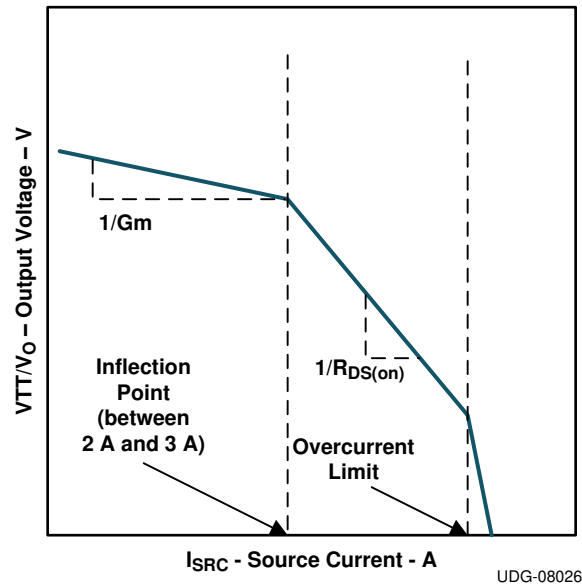

Figure 22. TPS7H3301-SP Impedance Characteristics

8.2.3 Application Curve

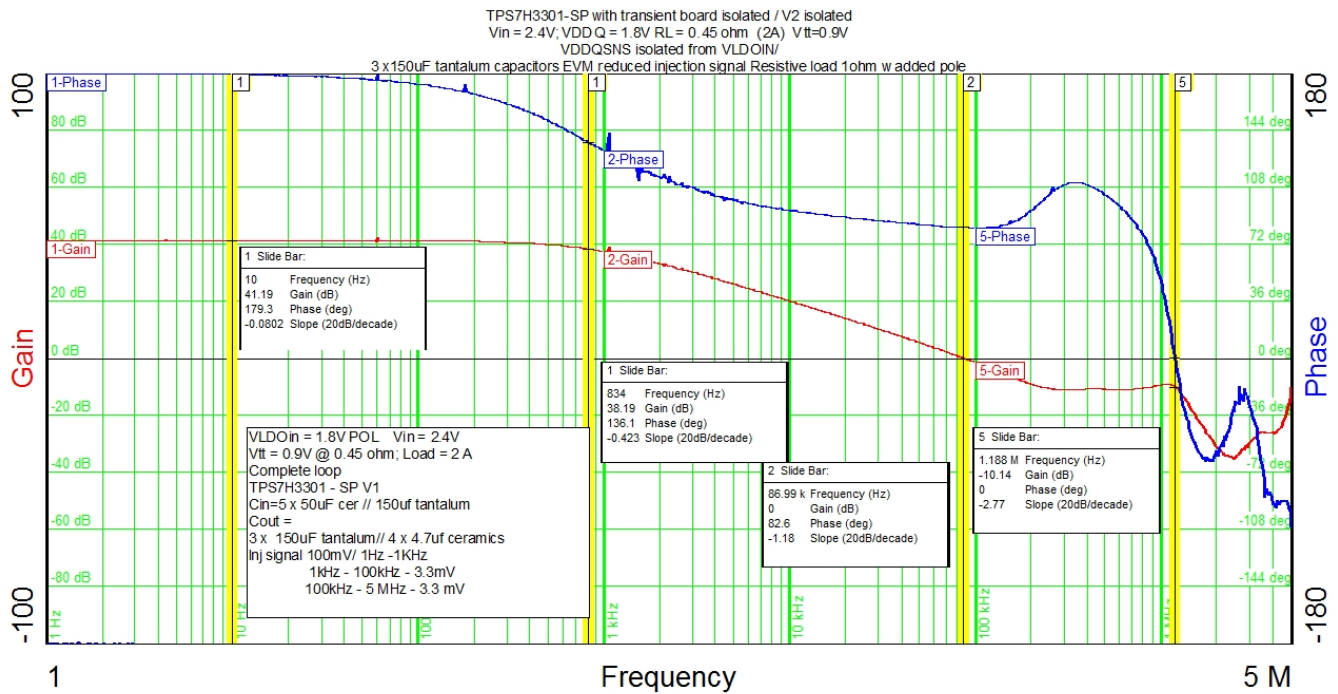

Figure 23. DDR2 2-A Load $V_{IN} = 2.4 V$, $V_{TT}/V_O = 0.9 V$

9 Power Supply Recommendations

TPS7H3301-SP is designed to support DDR, DDR2, DDR3, DDR3L, and DDR4 VTT applications. TPS7H3301-SP VLDOIN supports voltage range from 0.9 V to 3.5 V. The supply must be well regulated. Having a separate VLDOIN supply from DDR VDDQ allows designer to optimize system efficiency. VDD/V_{IN} is used to bias the TPS7H3301-SP IC and its voltage range from 2.375 V to 3.5 V. This supply must be well regulated and bypassed with a ceramic capacitor with a value of 1 μF and 10 μF. TI recommends that VLDOIN and DDR supply VDDQ be isolated from each other. If this is not possible then an RC filter must be used to isolate VLDOIN and VDDQNS. However, in so doing the dynamic tracking of VTT and VTTREF will be lost. See the EVM user's guide [SLVUAK2](#) for additional details.

10 Layout

10.1 Layout Guidelines

Consider the following points before starting the TPS7H3301-SP layout design.

- The input bypass capacitor for VLDOIN should be placed as close as possible to the pin with short and wide connections.
- The output capacitor for VTT/V_O should be placed close to the pin with short and wide connection in order to avoid additional ESR and/or ESL trace inductance.
- VTTSNS should be connected to the positive node of VTT/V_O output capacitors as a separate trace from the high-current power line. This configuration is strongly recommended to avoid additional ESR and/or ESL. If sensing the voltage at the point of the load is required, it is recommended to attach the output capacitor or capacitors at that point. Also, it is recommended to minimize any additional ESR and/or ESL of ground trace between the GND pin and the output capacitor or capacitors.
- Consider adding low-pass filter at VTTSNS if the ESR of the VTT/V_O output capacitor or capacitors is larger than 2 mΩ.
- VDDQSNS can be connected separately from VLDOIN. Remember that this sensing potential is the reference voltage of VTTREF. Avoid any noise-generating lines.
- The negative node of the VTT/V_O output capacitor or capacitors and the VTTREF capacitor should be tied together by avoiding common impedance to the high-current path of the VTT/V_O sink and source current.
- The GND and PGND pins should be connected to the thermal land underneath the die pad with multiple vias connecting to the internal system ground planes (for better result, use at least two internal ground planes). Use as many vias as possible to reduce the impedance between PGND/GND and the system ground plane. Also, place bulk caps close to the DIMM/module or memory load point and route the VTTSNS to the DIMM/module load sense point.
- In order to effectively remove heat from the package, properly prepare the thermal land. Apply solder directly to the package's thermal pad. The wide traces of the component and the side copper connected to the thermal land pad help to dissipate heat. Numerous vias, 0.33 mm in diameter or smaller, connected from the thermal land to the internal/solder side ground plane or planes should also be used to help dissipation.

10.2 Layout Example

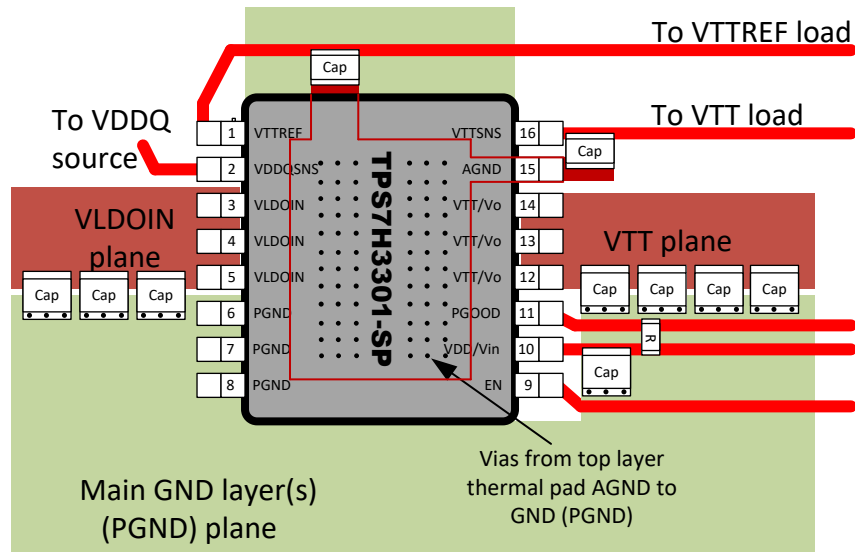

Figure 24. Layout Recommendation

10.3 Thermal Considerations

VTT/V_O current can flow in both source and sink directions. As the TPS7H3301-SP is a linear regulator, power is dissipated internal to the device. When the device is sourcing current, the voltage difference between VLDOIN and VTT/V_O times IO (I_{IO}) current becomes the power dissipation as shown in [Equation 2](#).

$$P_{\text{DISS_SRC}} = (V_{\text{VLDOIN}} - V_{\text{VO}}) \times I_{\text{O_SRC}} \quad (2)$$

In this case, if VLDOIN is connected to an alternative power supply lower than the VDDQ voltage, overall power loss can be reduced. For the sink phase, V_O voltage is applied across the internal LDO regulator and the power dissipation (P_{DISS_SNK}) can be calculated by [Equation 3](#).

$$P_{\text{DISS_SNK}} = V_{\text{VO}} \times I_{\text{O_SNK}} \quad (3)$$

Because the device does not sink and source current at the same time and the IO current may vary rapidly with time, the actual power dissipation should be the time average of the above dissipations over the thermal relaxation duration of the system. Another source of power consumption is the current used for the internal current control circuitry from the VDD/V_{IN} supply and the VLDOIN supply. This can be estimated as 5 mW or less during normal operating conditions. This power must be effectively dissipated from the package.

The thermal performance of an LDO depends on the printed circuit board (PCB) layout. Because the TPS7H3301-SP device is shipped unformed, only the recommended heat pad pattern is shown. Lead pad placement depends on final form factor.

To further improve the thermal performance of this device, using a larger than recommended thermal land as well as increasing the number of vias helps lower the thermal resistance from junction to heat slug.

11 Device and Documentation Support

11.1 Device Support

11.1.1 Third-Party Products Disclaimer

TI'S PUBLICATION OF INFORMATION REGARDING THIRD-PARTY PRODUCTS OR SERVICES DOES NOT CONSTITUTE AN ENDORSEMENT REGARDING THE SUITABILITY OF SUCH PRODUCTS OR SERVICES OR A WARRANTY, REPRESENTATION OR ENDORSEMENT OF SUCH PRODUCTS OR SERVICES, EITHER ALONE OR IN COMBINATION WITH ANY TI PRODUCT OR SERVICE.

11.2 Documentation Support

11.2.1 Related Documentation

For related documentation see the following:

- Texas Instruments, [TPS7H3301-SP Single-Event Effects Summary radiation report](#) (SLAK008)
- Texas Instruments, [TPS7H3301EVM-CVAL \(HREL022\) user's guide](#) (SLVUAK2)

11.3 Receiving Notification of Documentation Updates

To receive notification of documentation updates, navigate to the device product folder on ti.com. In the upper right corner, click on *Alert me* to register and receive a weekly digest of any product information that has changed. For change details, review the revision history included in any revised document.

11.4 Support Resources

[TI E2E™ support forums](#) are an engineer's go-to source for fast, verified answers and design help — straight from the experts. Search existing answers or ask your own question to get the quick design help you need.

Linked content is provided "AS IS" by the respective contributors. They do not constitute TI specifications and do not necessarily reflect TI's views; see TI's [Terms of Use](#).

11.5 Trademarks

E2E is a trademark of Texas Instruments.

All other trademarks are the property of their respective owners.

11.6 Electrostatic Discharge Caution



These devices have limited built-in ESD protection. The leads should be shorted together or the device placed in conductive foam during storage or handling to prevent electrostatic damage to the MOS gates.

11.7 Glossary

[SLYZ022](#) — *TI Glossary*.

This glossary lists and explains terms, acronyms, and definitions.

12 Mechanical, Packaging, and Orderable Information

The following pages include mechanical, packaging, and orderable information. This information is the most current data available for the designated devices. This data is subject to change without notice and revision of this document. For browser-based versions of this data sheet, refer to the left-hand navigation.

PACKAGING INFORMATION

Orderable Device	Status (1)	Package Type	Package Drawing	Pins	Package Qty	Eco Plan (2)	Lead finish/ Ball material (6)	MSL Peak Temp (3)	Op Temp (°C)	Device Marking (4/5)	Samples
5962-1422801VXC	ACTIVE	CFP	HKR	16	25	RoHS-Exempt & Green	NIAU	N / A for Pkg Type	-55 to 125	5962-1422801VXC TPS7H3301-SP	Samples
5962R1422801VXC	ACTIVE	CFP	HKR	16	25	RoHS-Exempt & Green	NIAU	N / A for Pkg Type	-55 to 125	5962R1422801VXC TPS7H3301-RHA	Samples
TPS7H3301HKR/EM	ACTIVE	CFP	HKR	16	25	RoHS-Exempt & Green	NIAU	N / A for Pkg Type	25 to 25	TPS7H3301HKREM	Samples

(1) The marketing status values are defined as follows:

ACTIVE: Product device recommended for new designs.

LIFEBUY: TI has announced that the device will be discontinued, and a lifetime-buy period is in effect.

NRND: Not recommended for new designs. Device is in production to support existing customers, but TI does not recommend using this part in a new design.

PREVIEW: Device has been announced but is not in production. Samples may or may not be available.

OBSELETE: TI has discontinued the production of the device.

(2) **RoHS:** TI defines "RoHS" to mean semiconductor products that are compliant with the current EU RoHS requirements for all 10 RoHS substances, including the requirement that RoHS substance do not exceed 0.1% by weight in homogeneous materials. Where designed to be soldered at high temperatures, "RoHS" products are suitable for use in specified lead-free processes. TI may reference these types of products as "Pb-Free".

RoHS Exempt: TI defines "RoHS Exempt" to mean products that contain lead but are compliant with EU RoHS pursuant to a specific EU RoHS exemption.

Green: TI defines "Green" to mean the content of Chlorine (Cl) and Bromine (Br) based flame retardants meet JS709B low halogen requirements of <=1000ppm threshold. Antimony trioxide based flame retardants must also meet the <=1000ppm threshold requirement.

(3) MSL, Peak Temp. - The Moisture Sensitivity Level rating according to the JEDEC industry standard classifications, and peak solder temperature.

(4) There may be additional marking, which relates to the logo, the lot trace code information, or the environmental category on the device.

(5) Multiple Device Markings will be inside parentheses. Only one Device Marking contained in parentheses and separated by a "~" will appear on a device. If a line is indented then it is a continuation of the previous line and the two combined represent the entire Device Marking for that device.

(6) Lead finish/Ball material - Orderable Devices may have multiple material finish options. Finish options are separated by a vertical ruled line. Lead finish/Ball material values may wrap to two lines if the finish value exceeds the maximum column width.

Important Information and Disclaimer:The information provided on this page represents TI's knowledge and belief as of the date that it is provided. TI bases its knowledge and belief on information provided by third parties, and makes no representation or warranty as to the accuracy of such information. Efforts are underway to better integrate information from third parties. TI has taken and continues to take reasonable steps to provide representative and accurate information but may not have conducted destructive testing or chemical analysis on incoming materials and chemicals. TI and TI suppliers consider certain information to be proprietary, and thus CAS numbers and other limited information may not be available for release.

In no event shall TI's liability arising out of such information exceed the total purchase price of the TI part(s) at issue in this document sold by TI to Customer on an annual basis.

TUBE

*All dimensions are nominal

Device	Package Name	Package Type	Pins	SPQ	L (mm)	W (mm)	T (μm)	B (mm)
5962-1422801VXC	HKR	CFP	16	25	506.98	26.16	6220	NA
5962R1422801VXC	HKR	CFP	16	25	506.98	26.16	6220	NA
TPS7H3301HKR/EM	HKR	CFP	16	25	506.98	26.16	6220	NA

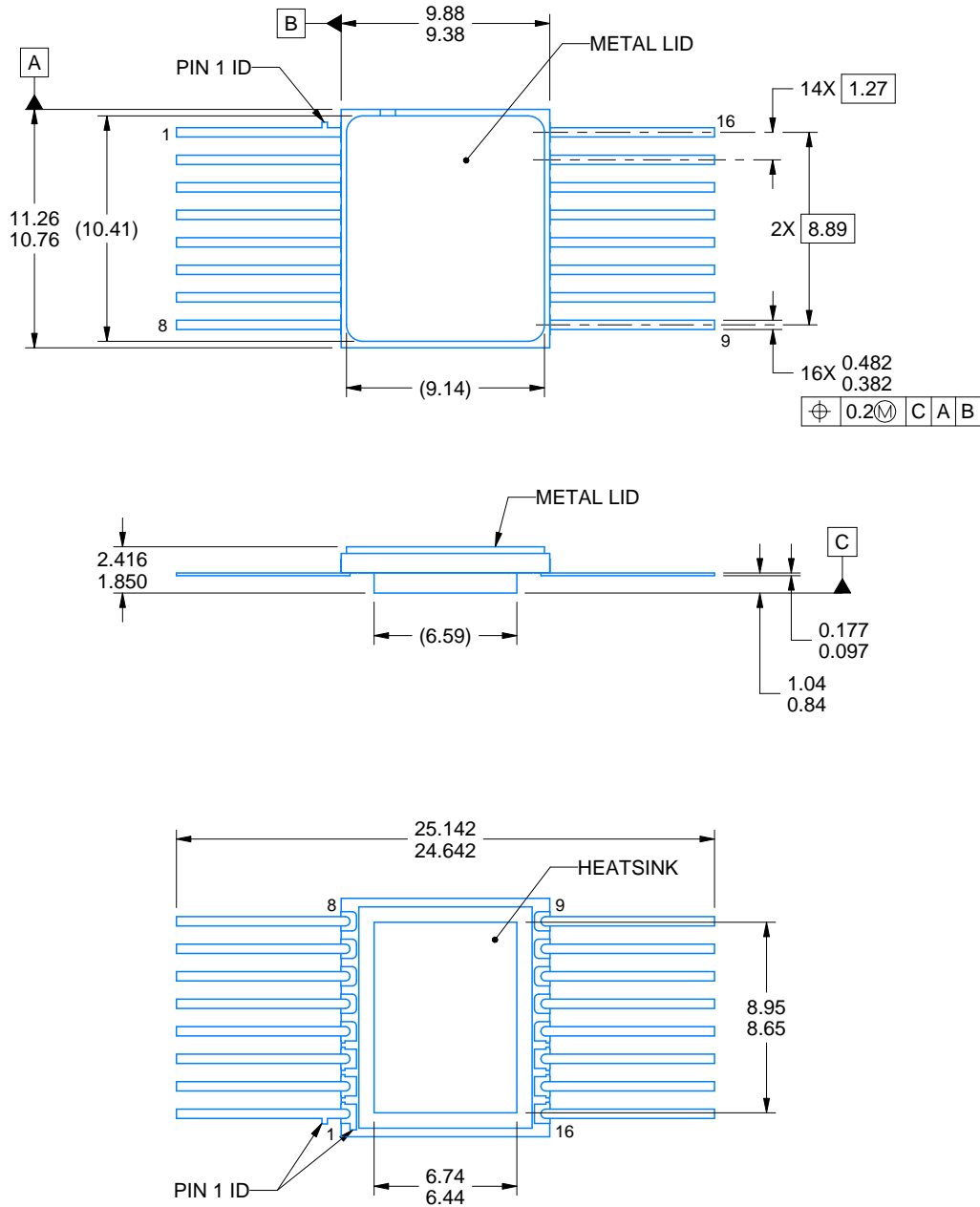
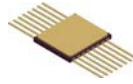

4226020/C 08/2022

NOTES:

1. All linear dimensions are in millimeters. Any dimensions in parenthesis are for reference only. Dimensioning and tolerancing per ASME Y14.5M.
2. This drawing is subject to change without notice.
3. This package is hermetically sealed with a metal lid. Lid is connected to Heatsink.
4. The terminals are gold plated.
5. Falls within MIL-STD-1835 CDFP-F11A.

EXAMPLE BOARD LAYOUT

HKR0016A

CFP - 2.416 mm max height

CERAMIC DUAL FLATPACK

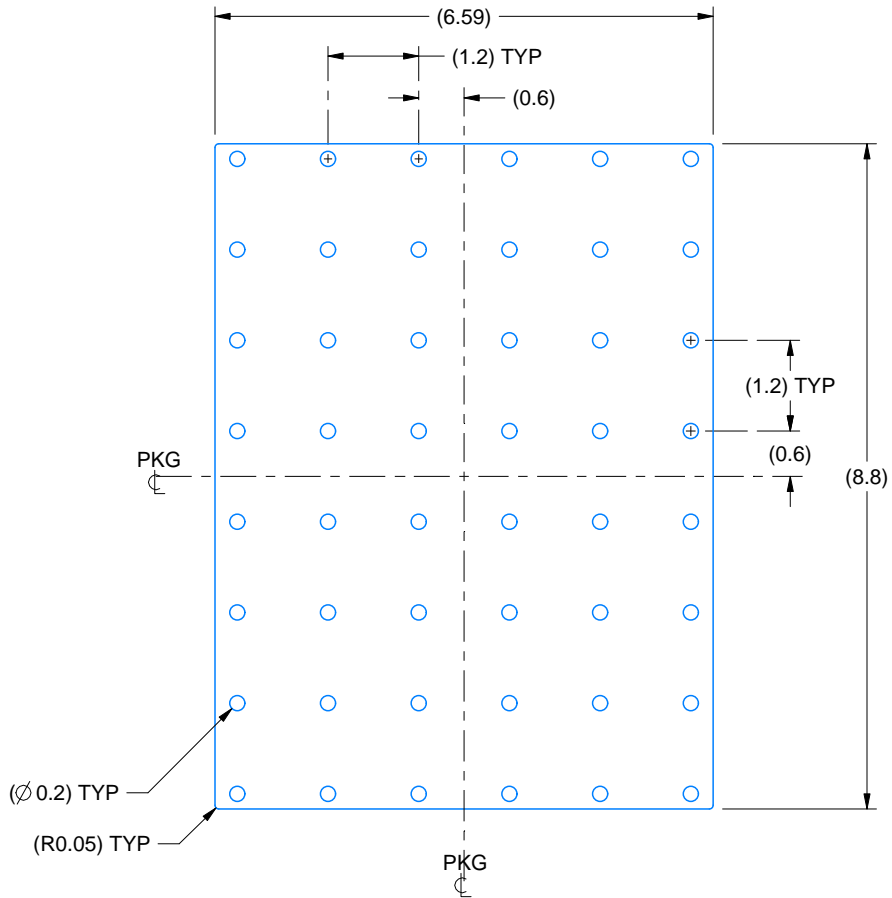

HEATSINK LAND PATTERN EXAMPLE
EXPOSED METAL SHOWN
SCALE:10X

4226020/C 08/2022

IMPORTANT NOTICE AND DISCLAIMER

TI PROVIDES TECHNICAL AND RELIABILITY DATA (INCLUDING DATA SHEETS), DESIGN RESOURCES (INCLUDING REFERENCE DESIGNS), APPLICATION OR OTHER DESIGN ADVICE, WEB TOOLS, SAFETY INFORMATION, AND OTHER RESOURCES "AS IS" AND WITH ALL FAULTS, AND DISCLAIMS ALL WARRANTIES, EXPRESS AND IMPLIED, INCLUDING WITHOUT LIMITATION ANY IMPLIED WARRANTIES OF MERCHANTABILITY, FITNESS FOR A PARTICULAR PURPOSE OR NON-INFRINGEMENT OF THIRD PARTY INTELLECTUAL PROPERTY RIGHTS.

These resources are intended for skilled developers designing with TI products. You are solely responsible for (1) selecting the appropriate TI products for your application, (2) designing, validating and testing your application, and (3) ensuring your application meets applicable standards, and any other safety, security, regulatory or other requirements.

These resources are subject to change without notice. TI grants you permission to use these resources only for development of an application that uses the TI products described in the resource. Other reproduction and display of these resources is prohibited. No license is granted to any other TI intellectual property right or to any third party intellectual property right. TI disclaims responsibility for, and you will fully indemnify TI and its representatives against, any claims, damages, costs, losses, and liabilities arising out of your use of these resources.

TI's products are provided subject to [TI's Terms of Sale](#) or other applicable terms available either on [ti.com](https://www.ti.com) or provided in conjunction with such TI products. TI's provision of these resources does not expand or otherwise alter TI's applicable warranties or warranty disclaimers for TI products.

TI objects to and rejects any additional or different terms you may have proposed.

Mailing Address: Texas Instruments, Post Office Box 655303, Dallas, Texas 75265
Copyright © 2024, Texas Instruments Incorporated

Looking for pricing, stock, or lifecycle information?

Click below to explore more details on WIN SOURCE:

 [View TPS7H3301HKR/EM on WIN SOURCE](#)

 [Texas Instruments](#) Information

Optimize Your Supply Chain with WIN SOURCE Solutions

-  Global Sourcing Solution
-  Obsolete Management
-  Cost Control Management
-  Shortage Management
-  Alternative Solution
-  Excess Inventory Management