



THE DATASHEET OF TMDSIDK574



AM574x Industrial Development Kit (IDK) Evaluation Module (EVM) Hardware

User's Guide



Literature Number: SPRUIJ9

April 2018

Preface	5
1 Introduction	6
1.1 Description	6
1.2 REACH Compliance	6
1.3 System View	7
2 Functional Description	11
2.1 Processor	12
2.2 Clocks	12
2.3 Reset Signals	12
3 Power Supplies	13
3.1 Power Source	13
3.2 TPS6590379 PMIC	13
3.3 AVS Control	13
3.4 Other Power Supplies	13
4 Configuration/Setup	15
4.1 Boot Configuration	15
4.2 I2C Address Assignments	15
4.3 SEEPROM Header	16
4.4 JTAG Emulation	16
5 Memories Supported	17
5.1 DDR3L SDRAM	17
5.2 SPI NOR Flash	17
5.3 Board Identity Memory	17
5.4 SD/MMC	17
5.5 eMMC NAND Flash	17
6 Ethernet Ports	18
6.1 100Mb Ethernet Ports on PRU-ICSS	18
6.2 Gigabit (1000Mb) Ethernet Ports	18
7 USB Ports	19
7.1 Processor USB Port 1	19
7.2 Processor USB Port 2	19
7.3 FTDI USB Port	19
8 PCIe	19
9 Video Input and Output	20
9.1 Camera	20
9.2 HDMI	20
9.3 LCD	20
10 Industrial Interfaces	20
10.1 Profibus	20
10.2 DCAN	20
10.3 RS-485	20

11	User Interfaces	21
11.1	Tri-color LEDs	21
11.2	Industrial Inputs	21
11.3	Industrial Outputs / LEDs	21
12	Pin Use Description	21
12.1	Functional Interface Mapping	21
12.2	GPIO Pin Mapping.....	21
13	Board Connectors	23
14	EVM Important Notice	36
Appendix A	Known Deficiencies in AM574x IDK EVM	37
A.1	Power solution not sufficient for full PCIe plug-in card compliance.....	37
A.2	AM574x IDK EVM does not support eMMC HS200 mode.....	37
A.3	PCIe PERSTn line not in proper state at start-up.....	37
A.4	EDIO connectors J4 and J7 should support real-time debugging for both PRU1 and PRU2	37
A.5	HDQ implementation not correct	37
A.6	Removing the power plug and inserting it again while the power supply is energized may cause damage	37
A.7	Software shutdown of PMIC not operational	38
A.8	PMIC implementation does not support required SOC shut-down sequence	38
A.9	USB port providing UART console and XDS100 emulation not isolated from EVM board supplies	38
A.10	Need 47- μ f capacitor at camera header.....	38
A.11	Decoupling capacitors do not reflect AM574x PDN recommendations	38
A.12	CCS System Reset fails	38
A.13	AM574x IDK EVM design contains 2 clamp circuits that may not be necessary	39
A.14	Crystal connected to osc0 needs to have 50 ppm or better long term accuracy	39
A.15	Software must program the CDCE913 for 0-pf load capacitance.....	39
A.16	PHY address LSB for U9 and U15 can be latched incorrectly	39

List of Figures

1	AM574x IDK EVM - Top View.....	7
2	AM574x IDK EVM - Bottom View.....	8
3	AM574x IDK EVM with LCD Display Assembly Attached - Top View	9
4	AM574x IDK EVM with LCD Display Assembly Attached - Bottom View.....	10
5	AM574x IDK EVM Block Diagram	11
6	Connections from the TPS6590379 PMIC to the AM574x Processor.....	14

List of Tables

1	I2C1/IND_I2C	15
2	I2C2/AM574X_HDMI_DDC	15
3	SEEPROM Header.....	16
4	PRU-ICSS Ethernet Ports.....	18
5	GPIO Pin Mapping	22
6	Expansion Connector - J21	23
7	I/O Expansion Header Connector - J37	25
8	MicroSD Connector - J15	26
9	Power Jack Connector - J1	26
10	Power Terminal Block Connector - J2.....	26
11	PRU1ETH0 RJ45 Connector - J3.....	27
12	PRU1ETH1 RJ45 Connector - J5.....	27
13	PRU2ETH0 RJ45 Connector - J6.....	28
14	PRU2ETH1 RJ45 Connector - J8.....	28
15	PRU2ETH0 Test Header Connector - J7	29
16	PRU2ETH1 Test Header Connector - J4	29
17	Camera Connector - J9.....	29
18	GigE RJ45 Connector - J10.....	30
19	GigE RJ45 Connector - J12.....	30
20	LCD Module FFC Connector - J16.....	31
21	Touchscreen Controller FFC Connector - J17	31
22	HDMI Standard A-type Connector - J24	32
23	MIPI-60 JTAG Connector - J18	32
24	JTAG USB Micro-AB Connector - J19	34
25	USB Port 1 USB3.0 Standard A-type Connector - J23.....	34
26	USB Port 2 USB2.1 Micro-AB Connector - J45	34
27	CAN Header Connector - J38	35
28	Profibus DB9F Connector - J14	35
29	RS-485 Header Connector - J39	35
30	PCIe Connector - J22	36

Read This First

About This Manual

This document describes the hardware architecture of the AM574x Industrial Development Kit (IDK) Evaluation Module (EVM) (Part# TMDSIDK574IDK) that supports the Texas Instruments Sitara™ ARM® Cortex®-A15 AM574x processor family.

Glossary

TI Glossary—This glossary lists and explains terms, acronyms, and definitions.

Related Documentation From Texas Instruments

For product information, visit the Texas Instruments website at <http://www.ti.com>.

SPRAC76— [Sitara Processor Power Distribution Networks: Implementation and Analysis](#)

SPRS982— [AM574x Sitara Processors Silicon Revision 1.0 Data Manual](#)

SPRZ447— [AM574x Sitara Processors Silicon Errata](#). Describes the known exceptions to the functional specifications for the device.

SPRUIH8— [AM574x Technical Reference Manual](#). Details the integration, the environment, the functional description, and the programming models for each peripheral and subsystem in the device.

Community Resources

The following links connect to TI community resources. Linked contents are provided "AS IS" by the respective contributors. They do not constitute TI specifications and do not necessarily reflect TI's views; see TI's [Terms of Use](#).

TI E2E™ Online Community— *TI's Engineer-to-Engineer (E2E) Community*. Created to foster collaboration among engineers. At e2e.ti.com, you can ask questions, share knowledge, explore ideas and help solve problems with fellow engineers.

TI Embedded Processors Wiki— *Texas Instruments Embedded Processors Wiki*. Established to help developers get started with Embedded Processors from Texas Instruments and to foster innovation and growth of general knowledge about the hardware and software surrounding these devices.

Trademarks

Sitara, E2E, Code Composer Studio, SmartReflex are trademarks of Texas Instruments.
ARM, Cortex are registered trademarks of ARM Limited.
Windows is a registered trademark of Microsoft Corporation.

AM574x Industrial Development Kit (IDK) Evaluation Module (EVM) Hardware

1 Introduction

This document describes the hardware architecture of the AM574x Industrial Development Kit (IDK) Evaluation Module (EVM) (Part# TMDSIDK574IDK) that supports the Texas Instruments Sitara™ ARM® Cortex®-A15 AM574x processor family.

1.1 Description

The AM574x IDK is a standalone test, development, and evaluation module that enables developers to write software and develop hardware for industrial control and industrial communications applications. It has been equipped with a TI AM5748 processor and a defined set of features to allow you to experience industrial communication solutions using various serial or Ethernet based interfaces. Using standard interfaces, the AM574x IDK may interface to other processors or systems and act as a communication gateway or controller. In addition, it can directly operate as a standard remote I/O system or a sensor connected to an industrial communication network.

The AM574x IDK contains embedded emulation circuitry to quickly enable developers to begin using this IDK. The embedded emulation logic allows emulation and debug using standard development tools such as the Texas Instruments Code Composer Studio™ integrated development environment (IDE) by simply connecting a USB cable to a Windows®-based computer.

The standard configuration for the AM574x IDK EVM provides the following Ethernet connectivity:

- Two Gigabit (1000Mb) metallic ports connected via PHY/RGMII to the on-chip Ethernet switch
- Two 100Mb metallic ports connected via PHY/MII to the PRU-ICSS subsystems

Reconfiguration through resistor removal and installation can provide an alternate Ethernet connectivity:

- Four 100Mb metallic ports connected via PHY/MII to the PRU-ICSS subsystems

Software support for the AM574x IDK EVM is provided within the Processor Software Development Kit (SDK) package. This includes both Linux and RTOS support.

1.2 REACH Compliance

In compliance with the Article 33 provision of the EU REACH regulation, we are notifying you that this module includes crystals (ABM3-25.000MHz-B2-T, ABM3-12.000MHz-D2Y-T) from Abracon LLC that contains two Substance of Very High Concern (SVHC) above 0.1%. These uses from Texas Instruments do not exceed 1 ton per year. The SVHC's are Diboron trioxide CAS# 1303-86-2 and Lead Oxide CAS# 1317-36-8.

1.3 System View

The system view of the AM574x IDK EVM consists of the main board and the camera board. There is also an optional LCD panel and touch screen assembly that can be attached to the AM574x IDK EVM.

The top and the bottom views of the AM574x IDK EVM are provided in [Figure 1](#) and [Figure 2](#), respectively.

The top and the bottom views of the AM574x IDK EVM with the optional LCD display assembly attached are provided in [Figure 3](#) and [Figure 4](#), respectively.

Figure 1. AM574x IDK EVM - Top View

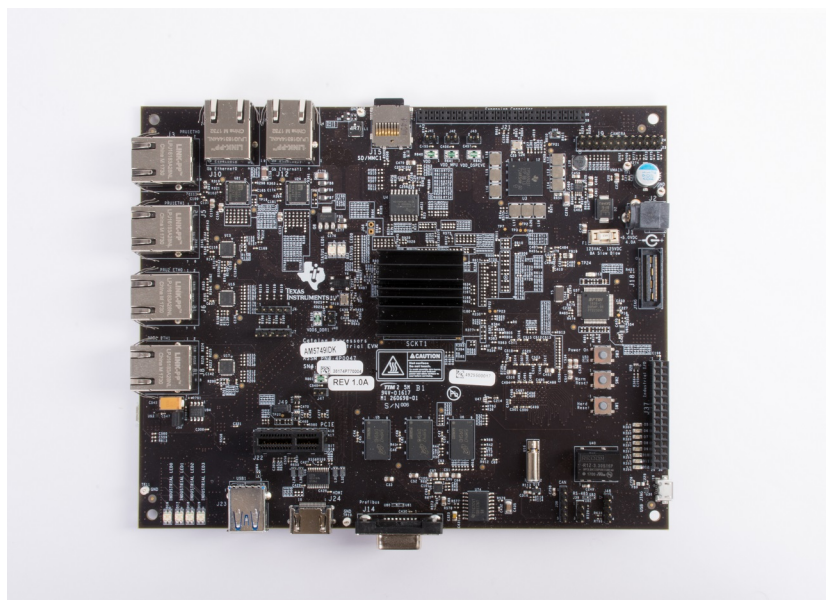

Figure 2. AM574x IDK EVM - Bottom View

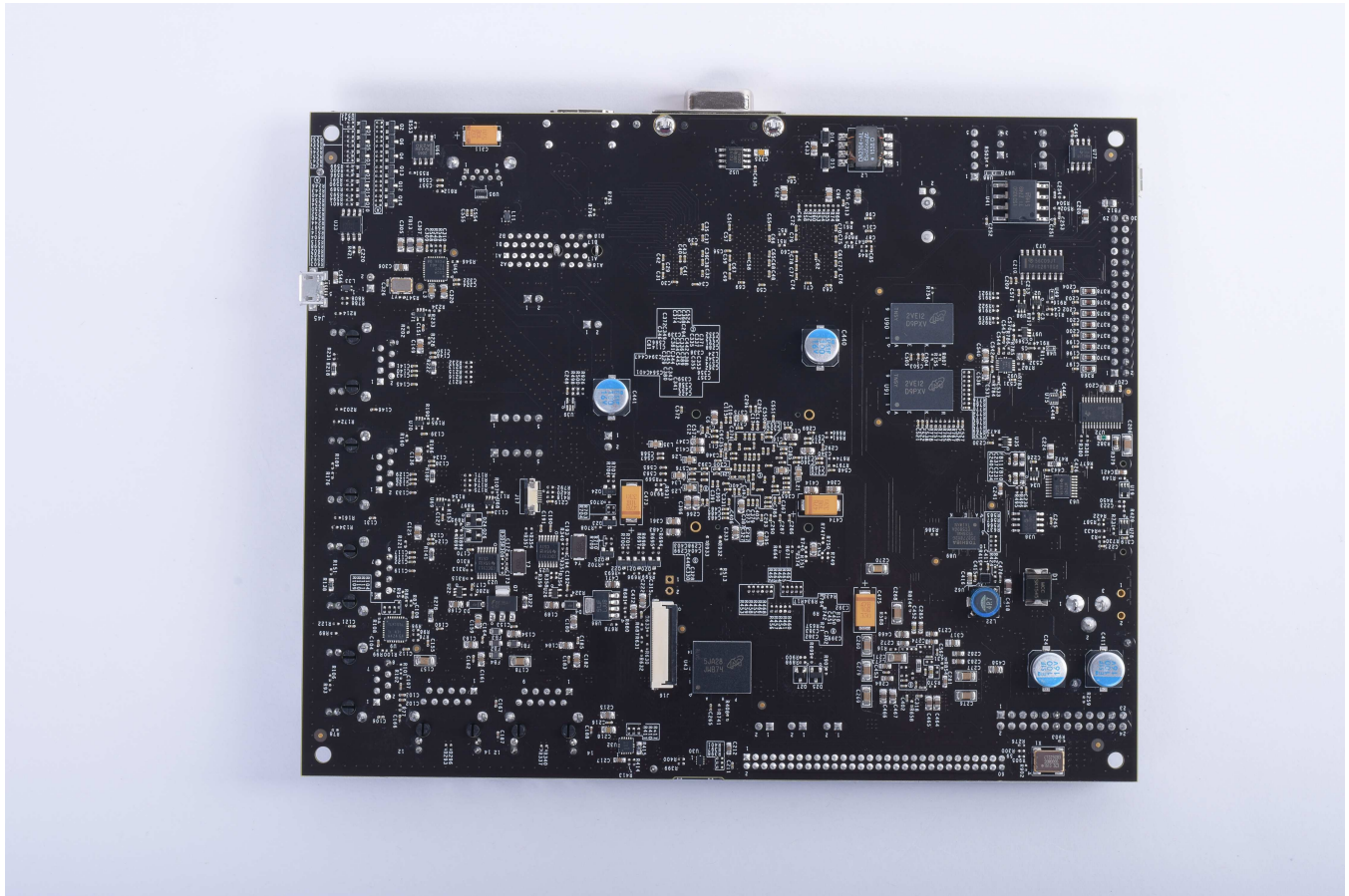

Figure 3. AM574x IDK EVM with LCD Display Assembly Attached - Top View



Figure 4. AM574x IDK EVM with LCD Display Assembly Attached - Bottom View



2 Functional Description

The AM574x IDK EVM is implemented on a single board with interface circuitry, memory ICs, and connectors around the AM5748 processor. The board also contains power conversion circuitry to efficiently create the needed power supply voltages from a single +5V input. As stated previously, this EVM ships with a separate camera module that plugs in to the main board. An optional LCD panel and touch screen assembly can be purchased separately and mounted on to the main board.

Figure 5 shows the functional block diagram of the AM574x IDK EVM.

Figure 5. AM574x IDK EVM Block Diagram

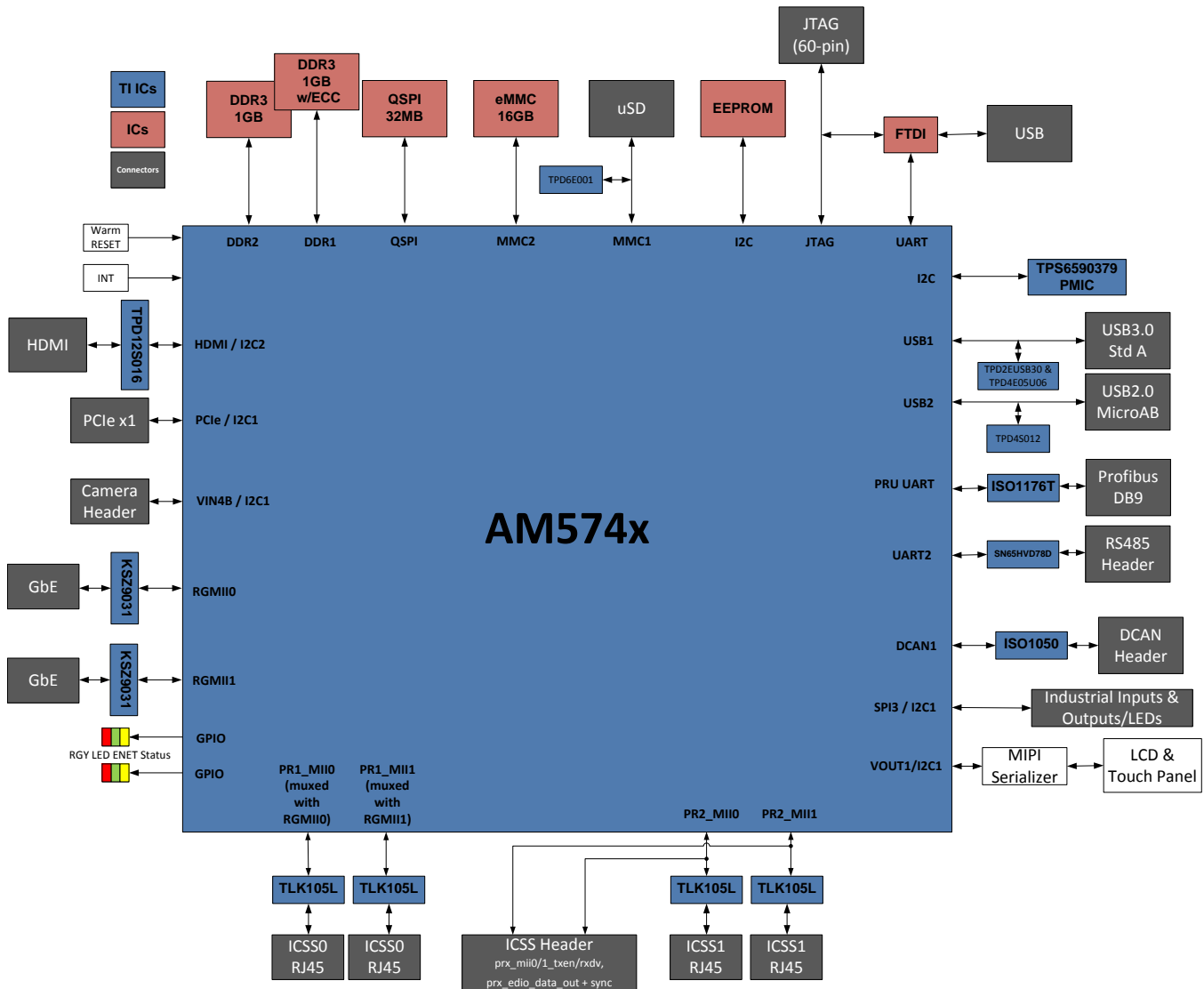

2.1 Processor

The AM5748 processor is the central processing unit for this IDK EVM. The interface circuitry, memory ICs, and connectors implemented on the board around the AM5748 processor provide development support for the many industrial communication interfaces available on this platform. See the [AM574x Sitara Processors Silicon Revision 1.0 Data Manual \(SPRS982\)](#) and the [AM574x Technical Reference Manual \(SPRUIH8\)](#) for details about the processor.

The AM574x IDK EVM contains system configuration for the boot mode control inputs SYSBOOT[15..0]. These can be strapped using resistors. The default configuration will meet the needs of most developers. Resistor reconfiguration is supported so that you can explore other boot configurations of the AM574x processor. See [Section 4](#) for more details.

2.2 Clocks

The main clock for the processor is derived from a 20-MHz crystal. An on-board oscillator in the AM574x processor generates the base clock and the subsequent module clocks as needed within the AM574x processor. The board design supports a crystal attached to the RTC block, but this is not needed since RTC-only mode is not supported in this device.

2.3 Reset Signals

The AM574x processor contains 3 reset inputs and an output indicating a reset is in progress. The reset pins are:

- PORz: PORz is a hard reset that resets everything including emulation logic. It also tri-states most outputs.
- RESETn: RESETn is a device reset commonly driven by control logic or emulation.
- RTC_PORz: Separate PORz for the RTC module that must be driven at the same time as PORz. (Note that PORz and RTC_PORz can only be directly connected as long as VDDSHV3 and VDDSHV5 are driven at the same voltage.)
- RSTOUTn: Output signal from SOC indicating that the device has entered reset. This is used to reset other circuits that must be reset at the same time as the processor.

More details about the behavior of these reset pins within the AM574x processor can be found in the [AM574x Sitara Processors Silicon Revision 1.0 Data Manual \(SPRS982\)](#). There are push buttons on the IDK that can initiate either a RESETn or PORz input. SW1 can drive PORz active (low) and SW2 can drive RESETn active (low).

There is a device erratum in all of the AM574x devices that prevents use of RESETn independent from PORz. The workaround is to generate PORz whenever a device reset occurs even if it is from an internal initiator. This is accomplished through cooperation with the PMIC paired with the AM574x device on the IDK EVM. The RSTOUTn output from the AM574x device is connected to the NRESWARM input of the PMIC. This initiates a re-start that drives RESET_OUT low and resets all voltages to their initial values. Since RESET_OUT from the PMIC is connected to PORz in the AM574x device, a hard reset is forced on the SOC that meets the needs of the erratum workaround.

The AM574x IDK EVM is started by pressing the start-up push button, SW3. The POWERHOLD input can be connected to VRTC_OUT in customer designs to cause the board to power-on as soon as the main supply is stable.

The configuration of the PMIC to provide RESET_OUT from the NRESWARM input creates an always-on implementation. This always-on mode of operation prevents software shut-down of the IDK. Customer designs should have power-good monitoring circuitry such as a TPS3808 connected to the main supply to the PMIC that is connected to the PMIC RESET_IN. The TPS3808 can detect the main supply voltage dropping and then trigger the PMIC to execute a controlled shut-down that meets the requirements in the [AM574x Sitara Processors Silicon Revision 1.0 Data Manual \(SPRS982\)](#).

3 Power Supplies

This section describes how the power supplies required for the design are generated.

3.1 Power Source

The AM574x IDK EVM uses an external 5V power supply. The 5V power input is converted into different voltage levels to provide power inputs to the AM574x processor and other circuitry.

Early versions of the AM574x IDK EVM shipped with the GlobTek, Inc. external power supply with the part number TR9CA6500LCP-N, model number GT-43008-3306-1.0-T3. This external power supply is rated for an output voltage of +5VDC with an output current up to 6.5A. This external power supply contains applicable regional product regulatory/safety certification requirements for most worldwide locations. If you cannot use this supply, one with equivalent ratings that is approved for your location must be obtained.

The AM574x IDK EVM contains a right angle mounted power connector that accepts the +5VDC supply input on the center pin with the outer shell as the common return. The power connector accepts a mating plug with a 2.5mm ID and a 5.5mm OD.

Removing the power plug and inserting it again while the power supply is energized may damage the AM574x IDK EVM and/or other devices attached to the board such as emulators that provide an alternate path to ground. Removal of AC power from the external power supply is a safer method, if required.

It is recommended that the external power supply have the common return bonded to earth ground. If this is not possible, a separate connection from the board ground to earth ground may need to be provided.

3.2 TPS6590379 PMIC

The power requirements of the processor are met by the TPS6590379 Power Management IC (PMIC). The power sequencing requirements of the AM574x processor are also handled by the TPS6590379 PMIC. [Figure 6](#) shows the supply connections from the TPS6590379 PMIC to the AM574x processor.

Refer to the [AM574x Sitara Processors Silicon Revision 1.0 Data Manual \(SPRS982\)](#) for more information about the required supply voltages and supply sequencing. Also refer to the [TPS659037 Power Management Unit \(PMU\) for Processor Data Manual \(SLIS165\)](#) and the [TPS659037 User's Guide to Power AM572x and AM571x User's Guide \(SLIU011\)](#) for details about its operation.

3.3 AVS Control

The AM574x processor consumes most of its power in its core logic. Therefore, minimizing the voltage supplied to this core logic can minimize power consumption. SmartReflex™ technology is used to provide this optimized solution.

This core logic is separated into multiple segments that can each be controlled separately. In this way, applications that need more performance in some processing blocks can operate at higher performance levels by increasing the supply voltage, while other processing blocks that do not require the same level of performance can operate at lower voltage thus further optimizing system power consumption.

The TPS6590379 PMIC is connected to the I2C1 on the AM5748 processor. This allows the application software to individually control the AVS supply outputs. It also allows the application to control the voltage generated by LDO1 that is used for the SDIO interface that operates at either 1.8V or 3.3V depending on the operating mode.

3.4 Other Power Supplies

The AM574x IDK EVM contains 8 other power conversion devices that support the interface and memory circuitry:

- **TPS63010 Buck-Boost Converter:** This converter generates 5.0V from the main supply input. It supplies this voltage to the industrial interface circuits, the HDMI interface and to the USB master ports.
- **TPS61085 Boost Converter:** This converter generates 12.0V from the main supply input. It supplies voltage to the industrial interface circuits and the PCIe card connector.
- **TPS51200 DDR Termination Voltage LDO (2 each):** This LDO provides the push/pull termination

- current required for the DDR3 memory interfaces. There is one implemented for each DDR3 EMIF.
- LP38693ADJ Low-Dropout Regulator: This LDO generates the 3.7V LCD bias voltage.
- TPS61081DRC LCD Backlight Generator: This Boost converter generates the LCD backlight supply.
- TPS71712 Low-Dropout Regulator: This LDO generates the 1.2V supply needed for the LCD driver logic.
- TPS76650 Low-Dropout Regulator: This LDO generates the 5.0V supply needed for the Profibus interface.
- R1Z-3.305HP Isolated DC-DC Supply: This converter generates 5.0V isolated from the primary 3.3V DC supply on board for the DCAN interface.

Figure 6. Connections from the TPS6590379 PMIC to the AM574x Processor

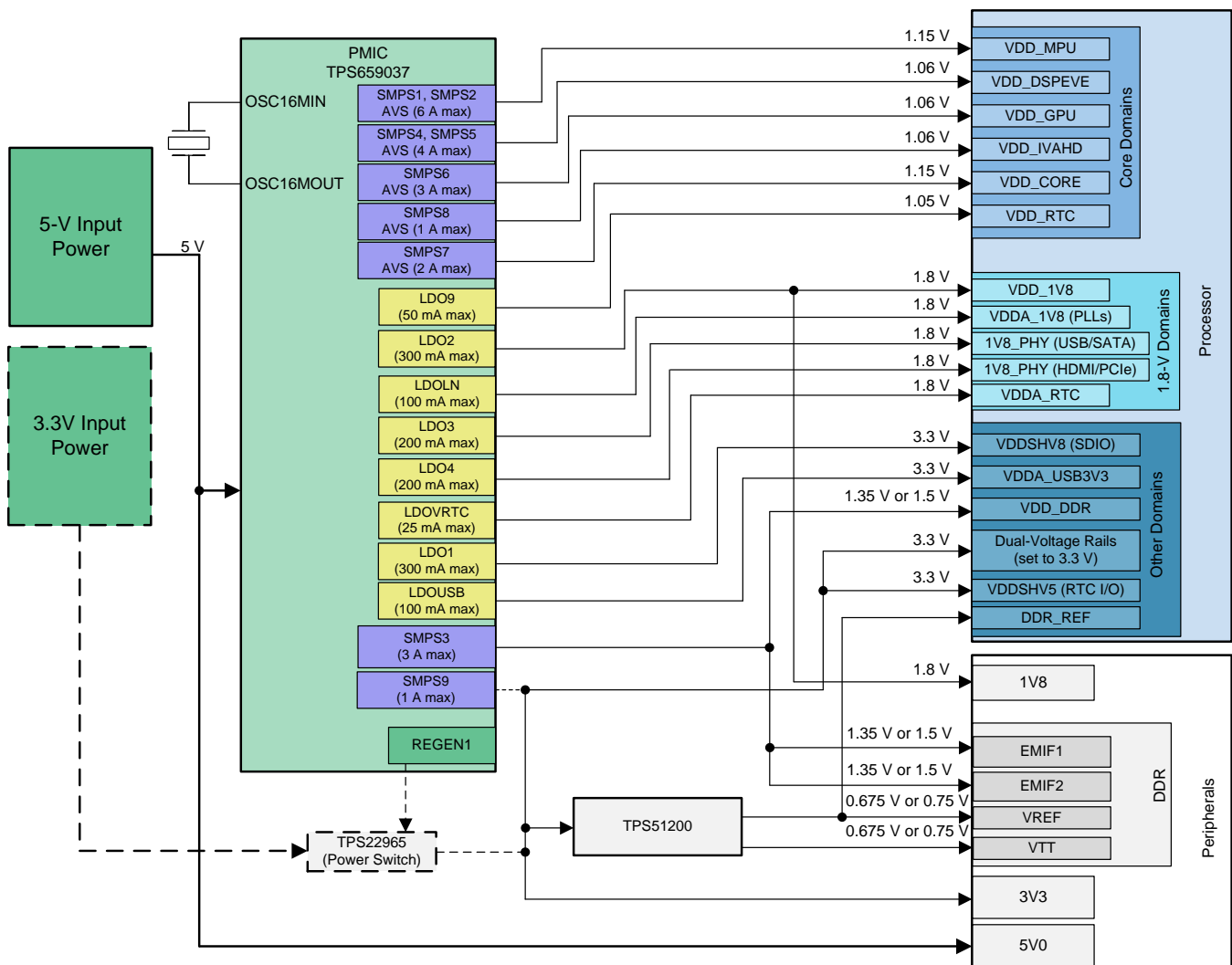

4 Configuration/Setup

This section discusses the board configuration.

4.1 Boot Configuration

Various boot configurations can be set using the pull-up/pull-down resistor combinations provided on the SYSBOOT[15..0] pins. Boot configuration pins are latched upon de-assertion of the PORz pin. Refer to the [AM574x Sitara Processors Silicon Revision 1.0 Data Manual \(SPRS982\)](#) for more details. The AM574x IDK EVM is configured by default to 0x8106 to enable UBOOT/Linux boot from the SDCARD. The secondary boot device selected by this boot mode is QSPI1.

4.2 I2C Address Assignments

The AM574x IDK EVM contains multiple I2C buses connected to a master port on the processor. Each bus contains one or more I2C slave devices that must have unique addresses to prevent contention. [Table 1](#) and [Table 2](#) list the addresses of the I2C slave devices attached to buses I2C1 and I2C2, respectively.

Table 1. I2C1/IND_I2C

I2C Slave Device	Address(es)
TPS590377 PMIC, U3	0x58, 0x59, 0x5A, 0x5B, 0x12
Camera Header, J9	Undefined
CDCE913 Ethernet Clock Generator A, U23	0x65
TPIC2810 Industrial Output Driver, U89	0x60
LCD Panel Driver TC358778, U73	0x0E
Touchscreen FPC Connector, J17	—
ID Memory SEEPROM, U33	0x50
PCIe Card Connector, J22	Undefined
Expansion Connector, J21	Undefined

Table 2. I2C2/AM574X_HDMI_DDC

I2C Slave Device	Address(es)
HDMI Bridge, U46	—
CDCE913 Ethernet Clock Generator B, U25	0x65

NOTE: SCL/SDA names are swapped between the HDMI DDC port and I2C2 port on AM57xx devices – I2C2 schematic connections to U25 must be reversed.

4.3 SEEPROM Header

Each of the AM574x IDK EVMs has a unique serial number. This serial number is printed on a sticker attached to the IDK and it is programmed into a SEEPROM memory device connected to the AM5748 processor over the I2C bus. The SEEPROM also contains board details such as board type, version, configuration, and so on. This information is stored in a structure at the beginning of the SEEPROM in a known format that can be read by the application software. These values are all stored with the first character or MSB stored at the lowest addressable location in each field. [Table 3](#) lists all of the fields in this header definition.

Table 3. SEEPROM Header

Name	Size (bytes)	Contents
Header	4	MSB 0xEE3355AA LSB
Board Name	8	Name for board in ASCII "AM574" = AM574x Industrial Development Kit EVM.
Version	4	Hardware version code for board in ASCII "1.3A" = revision 01.3A
Serial Number	12	Serial number of the board. This is a 12-character string that is: WWYY4P47nnnn, where WW = 2 digit week of the year of production, YY = 2 digit year of production, nnnn = incrementing board number.
Configuration Option	32	Codes to show the configuration setup on this board. Reserved.
Ethernet MAC Address #0	6	Ethernet MAC Address #0 assigned to the AM574x IDK EVM. This is the first of a block of addresses available for the Industrial Interface ports.
Ethernet MAC Address #5	6	Ethernet MAC Address #5 assigned to the AM574x IDK EVM. This is the last of a block of 6 contiguous addresses available for the industrial interface ports.
Available	32696	Available user space for other non-volatile codes/data.

4.4 JTAG Emulation

The AM574x IDK EVM supports embedded XDS100V2 USB Emulation through the USB Micro-AB connector, J19, and the FTDI controller. This controller is not powered from the USB, thus the emulation resets whenever the IDK is power cycled.

The AM574x IDK EVM also has a 60-pin MIPI connector to support high-performance external emulators and, optionally, emulation trace. This emulation trace capability is not enabled by default.

5 Memories Supported

The AM574x IDK EVM supports on-board memories including DDR3L SDRAM, SPI NOR Flash, eMMC NAND Flash, and I2C EEPROM. It also supports a MicroSD card socket that can add memory storage.

5.1 DDR3L SDRAM

The AM574x IDK EVM design supports two banks of DDR3L SDRAM where each is attached to a separate EMIF on the AM5748 processor. Each EMIF can support up to 2GB at speeds up to 1066MT/s. Each EMIF on the IDK EVM contains two 4Gbit (256M × 16) SDRAMs for a total of 1GB of DDR3L SDRAM memory on each EMIF. The part number for the DDR3L SDRAM memory used is MT41K256M16HA-125 that contains timing for 1600MT/s operation. The package used is the 96-ball TFBGA package. See the [AM574x Technical Reference Manual \(SPRUJH8\)](#) for memory locations for this memory.

The first EMIF also contains an SDRAM attached to the ECC byte lane.

5.2 SPI NOR Flash

The AM574x IDK EVM supports a 256Mbit (32MB) SPI Flash Memory from Spansion (S25FL256S) in a 16-pin SOIC package. It is connected to the QSPI port of the AM5748 device.

5.3 Board Identity Memory

Each of the AM574x IDK EVM boards contains a 256Kb (32KB) Serial EEPROM that contains board-specific data. This data allows the application software to automatically detect the type of board that it is running on and also to determine its version and, potentially, optional features. Other hardware specific data can be stored on this memory device as well. The part number of the memory device is CAT24C256WI-G in a SOIC-8 package. Refer to [Section 4](#) for details on the data stored in this memory.

5.4 SD/MMC

The SD/MMC connector on the AM574x IDK EVM is a MicroSD connector (part number SCHA5B0200). This is a standard SD/MMC card type of connector. It is connected to the MMC1 port of the AM574x processor that is optimized for this use. Refer to the [AM574x Sitara Processors Silicon Revision 1.0 Data Manual \(SPRS982\)](#) and the [AM574x Technical Reference Manual \(SPRUJH8\)](#) for supported card types and densities.

The SDWP input pin to the MMC1 port is connected to a 2-pin header, J44. The default state has the pin pulled high. Shorting the header pulls the pin low. The polarity of this input is programmable; thus, the hardware does not define whether a high or low level indicates Write Protect is active or not.

The transient protection implemented at the SDCARD connector is the TPD6E001.

5.5 eMMC NAND Flash

The MMC2 port on the AM574x processor supports eMMC memory devices, since it has 8 data lines. The eMMC footprint is compliant with the JEDEC/MMC standard. Boards have been assembled and successfully tested with the Kingston EMMC16G-S100 and the Micron MTFC16GAKAECN-2M WT. These are 16GB eMMC NAND Flash memories that are standard version 5.0 compliant.

6 Ethernet Ports

The AM574x IDK EVM supports up to four 100Mb Industrial Ethernet ports attached to the PRU-ICSS subsystems and up to two Gigabit (1000Mb) Ethernet ports connected to the integrated Ethernet switch. The final number of available ports depends on the configuration options. The default configuration provides two 100Mb Industrial Ethernet ports and two Gigabit (1000Mb) Ethernet ports.

6.1 100Mb Ethernet Ports on PRU-ICSS

The AM574x IDK EVM contains four 100Mb Ethernet ports that each connect to an industrial PHY/Transceiver (TLK105L), which then connect to RJ45 metallic connectors, with integrated magnetics, J3, J5, J6, and J8. These Ethernet transceivers are connected to the PRU1 and PRU2 subsystems within the AM5748 processor. [Table 4](#) shows the mapping from the PRU-ICSS ports to the RJ45 connectors.

The COL functionality on the MII interface is not used. The TLK105L contains a feature that must be enabled via software that provides rapid link status on the COL pin. Therefore, this pin is connected to the RXLINK input to the PRU-ICSS ports for this purpose.

Test headers J4 and J7 are available to support real-time code development. The signals contained are available for simplified probing.

The reset for the transceivers is driven low coincident with the PORz reset to the AM5748 processor. The reset for each transceiver can also be driven low individually by separate GPIO signals from the processor. A 25-MHz clock is provided into each of the TLK105L industrial transceivers.

Table 4. PRU-ICSS Ethernet Ports

Connector	PRU-ICSS Port	MDIO Address	Notes
J3	PRU1ETH0	0x0 on PRU1	Not available in default configuration. MII pins multiplexed with RGMII0.
J5	PRU1ETH1	0x1 on PRU1	Not available in default configuration. MII pins multiplexed with RGMII1.
J6	PRU2ETH0	0x0 on PRU2	
J8	PRU2ETH1	0x1 on PRU2	

6.2 Gigabit (1000Mb) Ethernet Ports

The AM574x IDK EVM contains two Gigabit (1000Mb) Ethernet PHY/Transceivers (KSZ9031RN) interfaced to connectors J10 (RGMII0) and J12 (RGMII1). These Gigabit Ethernet transceivers are connected over RGMII0 and RGMII1 to the Ethernet switch block within the AM5748 processor.

The resets for the transceivers are driven low coincident with the PORz reset to the AM5748 processor. A 25-MHz clock is provided into each of the KSZ9031RN Gigabit transceivers.

7 USB Ports

The AM574x IDK EVM contains three USB ports. Two ports are attached to the USB peripherals USB1 and USB2 on the AM574x processor. The third port provides both XDS100V2 JTAG emulation and UART Console over the USB. This port simplifies the development environment for programmers using computers that support this capability such as Windows®-based computers.

7.1 Processor USB Port 1

Processor port USB1 is implemented only as a USB host (master). It supports both USB2.1 (high speed) and USB3.0 (super speed) data rates. The connector on the board, J23, is a USB3.0 Standard A-type connector. The ESD devices implemented on this USB port are the TPD2EUSB30 for the DP and DM lines and the TPD4E05U06 for the super-speed pairs.

Since processor USB port 1 supports host mode, it has the capability to drive 5.0V power on the VBUS pin. The TPS2065D load switch is controlled by the USB1_DRVVBUS pin for this purpose.

7.2 Processor USB Port 2

Processor port USB2 is implemented as either USB host (master) or USB device (slave). It supports only the USB2.1 (high speed and lower) data rates. The connector on the board, J45, is a USB2.1 Micro-AB connector. The ESD device implemented on this USB port is the TPD4S012.

Since processor USB port 2 supports host mode, it has the capability to drive 5.0V power on the VBUS pin. The TPS2051 load switch is controlled by the USB2_DRVVBUS pin for this purpose.

The USB2.1 standard defines different ranges of capacitance for the VBUS pin depending on whether it is host or device. Since this port can do either, the AM574x IDK EVM provides the capability to meet either requirement. The VBUS pin from the connector contains a 4.7µF capacitor that is appropriate for device mode operation. When operating in host mode, 2-pin header J50 can be shorted to add 150µF of additional capacitance to the VBUS pin. The shunt for this header is shown on the schematic as M2. It is not installed on units when shipped as we expect this port to primarily be used in device mode.

7.3 FTDI USB Port

The FTDI bridge device provides both XDS100V2 JTAG emulation and UART Console over the USB. Its USB connector is J19 and it is also a USB Micro-AB connector but it only operates in device (slave) mode with the FTDI bridge device. The ESD device implemented on this USB port to the FTDI bridge is the TPD2E001. Refer to [Section 4.4](#) for more details on this functionality.

8 PCIe

The AM574x processors contain two lanes of peripheral component interconnect express (PCIe). These can be implemented either as a single, dual-lane port or as two single-lane ports. The PCIe peripheral can be configured to either be a Root Complex (master) or an Endpoint (slave). The AM574x IDK EVM only implements one single-lane port as a Root Complex. The IDK EVM terminates this lane in a single-lane PCIe female connector that accepts standard PCIe Endpoint cards.

A 2-pin header, J49, is available to provide the 3V3_AUX power separate from the primary 3V3 supply. This is needed for some cards and PCIe driver configurations. The shunt, shown on the schematic as M1, should be installed when the board is received since 3V3_AUX will be needed in most cases. Please refer to the documentation for the card being installed to determine whether this shunt should remain installed.

The PERSTn reset for the connector is driven low coincident with the PORz reset to the AM5748 processor. The PERSTn reset to the connector can also be driven low by a GPIO signal from the processor. This reset can also be blocked by a GPIO signal from the processor.

A 100-MHz clock is provided separately to both the PCIe peripheral and to the PCIe connector. These clocks are buffered outputs from the same low-jitter source.

The AM574x IDK EVM is compatible with standard PCIe plug-in cards but not fully compliant with the PCIe CEM standard. It does not support hot-plug and also does not provide sufficient current on the 3.3V and 12V pins for all plug-in cards. It is currently limited to about 0.5A on each supply.

9 Video Input and Output

The AM574x processor family supports industrial video capture and display in addition to its industrial communications capabilities. The AM574x IDK EVM contains a camera header for attaching a module containing a camera sensor as well as support for an LCD panel display and HDMI video output.

9.1 Camera

The AM574x IDK EVM supports a camera daughterboard that attaches to a 24-pin (2 × 24) header, J9. The custom-designed camera module from TI, previously designed for the AM437x IDK EVM, mounts on this header. This header is connected to VIN4B on the AM5748 processor.

The 2Mp camera board contains the Darling Industrial camera module (part number DC-OVBD420AH). The camera module contains the OmniVision OV2659 camera sensor. Please contact Omnivision for the latest documentation on this sensor.

9.2 HDMI

The AM574x IDK EVM supports an HDMI connector driven from the HDMI port on the AM5748 processor. The connector on the board, J24, is an HDMI Standard A-type connector. It is implemented with the TPD12S016 HDMI companion chip. This companion chip provides I2C level shifting buffers, 5V load switch, and multi-channel ESD protection.

9.3 LCD

The AM574x IDK EVM is available with an optional LCD panel that also has a capacitive touch overlay. The video output driven for the LCD panel from the AM5748 processor is on VOUT1. A MIPI bridge device from Toshiba, TC358778, is implemented to convert from the 24-bit RGB presented on the VOUT1 pins to serial MIPI RGB streams. The LCD panel is shipped with FPC cables that plug into J16 for the MIPI video and into J17 for the touchscreen controller. Both the MIPI bridge device and the touchscreen controller are connected to the IND_I2C chain from processor port I2C1.

10 Industrial Interfaces

There are additional industrial interfaces implemented on the AM574x IDK EVM to help showcase the flexibility of the AM57xx line of processors.

10.1 Profibus

A compliant Profibus interface is implemented using the ISO1176T isolation device, transformer and TPS76650 LDO regulator. This circuit terminates to a DB9F connector, J14. This Profibus interface is driven by UART0 from the first PRU-ICSS block, PR1.

10.2 DCAN

The AM5748 processor contains two Controller Area Network (DCAN) interfaces. DCAN port 1 is routed out to the ISO1050 isolation device and then to the 5-pin header, J38. The R1Z-3.305HP isolated DC-DC supply provides an isolated 3.3V supply for this DCAN interface.

10.3 RS-485

The AM574x IDK EVM contains an RS-485 interface on 3-pin header, J39. This is enabled by the SN65HVD78D Half-Duplex RS-485 Transceiver. The transceiver controls the half-duplex communication and also provides high-voltage transient protection. This interface is attached to the SOC-level UART2 port for RX and TX data. The UART TX data line is monitored by PR2_PRU1, so that PRU code can monitor TX activity and then control the DE and REN lines into the transceiver.

11 User Interfaces

The AM574x IDK EVM contains GPIO expanders that provide industrial inputs and outputs to support development. The outputs contain LEDs for immediate feedback. There are also tri-color LEDs connected to GPIOs to support development.

11.1 Tri-color LEDs

There are 6 tri-color LEDs connected to SOC GPIO pins that can be used to support development. There is a separate GPIO assigned for each color: red, green, and yellow. Color mixing by turning on more than one GPIO at a time will not provide the expected result since the separate colors have different intensities due to the physics of the LED composition. Tri-color LEDs D16, D17, D18, and D19 are designated Industrial LEDs. Tri-color LEDs D22 and D23 are designated Status LEDs.

11.2 Industrial Inputs

For industrial 24v digital inputs, an SN65HVS882 Digital-input Serializer for industrial digital inputs is used to accept standard signals from the 30-pin (15 × 2) I/O Expansion Header, J37. The input values are clocked into the SPI3 port of the AM5748 processor.

11.3 Industrial Outputs / LEDs

I2C to 8-bit LED driver TPIC2810 is used to drive the eight Industrial output LEDs D5 to D12. The I2C interface is connected to the I2C1 port of the AM5748 processor along with the other devices on the IND_I2C bus. The eight LED driver outputs are also driven to the I/O Expansion Header, J37. All the LEDs are green in color.

12 Pin Use Description

12.1 Functional Interface Mapping

Some signals of the AM5748 device are connected to a fixed device on the EVM where it cannot be changed. However, some of the signals of the AM5748 device are connected to devices on the AM574x IDK EVM based on the profile setting.

12.2 GPIO Pin Mapping

The developer can enable GPIO pins individually, as needed, as output, input, or both. Most of the LVCMOS pins not currently allocated for other peripheral use can be defined as GPIO pins. [Table 5](#) is a compliment to the schematic and the recommended settings in the pinmux tool. Each of the defined GPIO pins are listed along with the associated pin name and ball number and mode. The last column lists the available physical pull-up (PU) or pull-down (PD) resistor attached or the recommended internal pull-up or pull-down resistor defined in the pinmux file provided for the AM574x IDK EVM.

Table 5. GPIO Pin Mapping

Pin Name	GPIO #	Pin #	IDK Net Name / Function	Direction	Pull Up / Pull Down
MCASP2_AXR4	GPIO1_4	D15	AM57XX_INDEETHER_LED0_YEL	Output	EXT PD
MCASP2_AXR7	GPIO1_5	A17	AM57XX_INDEETHER_LED1_YEL	Output	EXT PD
MCASP2_AXR6	GPIO2_29	B17	AM57XX_INDEETHER_LED1_GRN	Output	EXT PD
VIN1A_D6	GPIO3_10	AG6	AM57XX_STATUSLED1_RED	Output	EXT PD
VIN1A_D7	GPIO3_11	AH4	AM57XX_STATUSLED0_GRN	Output	EXT PD
VIN1A_D8	GPIO3_12	AG4	AM57XX_STATUSLED0_YEL	Output	EXT PD
VIN1A_D10	GPIO3_14	AG3	TOUCH_INT	Input	INT PU
VIN1A_D12	GPIO3_16	AF2	GPIO_AM572X_USB2_ID	Input/Output	EXT PU
VIN1A_D13	GPIO3_17	AF6	AM57XX_INDEETHER_LED3_GRN	Output	EXT PD
VIN1A_D14	GPIO3_18	AF3	AM57XX_INDEETHER_LED3_YEL	Output	EXT PD
VIN1A_D15	GPIO3_19	AF4	AM57XX_GPIO_IND_LDn	Output	EXT PU
VIN1A_D17	GPIO3_21	AE3	GPIO_VPP_PWR_EN	Output	EXT PD
VIN1A_D18	GPIO3_22	AE5	GPIO_PCIE_RSTDRVn	Output	INT PD
VIN1A_D19	GPIO3_23	AE1	GPIO_PCIE_SWRSTn	Output	INT PU
VIN1A_D22	GPIO3_26	AD2	GPIO_USB2_VBUS_DET	Input	EXT PU
VIN2A_CLK0	GPIO3_28	E1	PRU1ETH0_INTn	Input	INT PU
VIN2A_DE0	GPIO3_29	G2	PRU1ETH1_INTn	Input	INT PU
VIN2A_FLD0	GPIO3_30	H7	PRU2ETH0_INTn	Input	INT PU
VIN2A_HSYNC0	GPIO3_31	G1	PRU2ETH1_INTn	Input	INT PU
VIN1A_D5	GPIO3_9	AH5	AM57XX_INDEETHER_LED0_GRN	Output	EXT PD
VIN2A_VSYNC0	GPIO4_0	G6	AM57XX_STATUSLED0_RED	Output	EXT PD
VOUT1_FLD	GPIO4_21	B11	eMMC_RSTn	Output	EXT PU
MCASP1_ACLKR	GPIO5_0	B14	GB_ETH0_INTn	Input	EXT PU
MCASP1_FSR	GPIO5_1	J14	GB_ETH1_INTn	Input	EXT PU
MCASP1_AXR2	GPIO5_4	G13	PCIE_CRDPRESENT	Input	EXT PU
MCASP1_AXR3	GPIO5_5	J11	PCIE_WAKEn	Input	EXT PU
MCASP1_AXR4	GPIO5_6	E12	GPIO_PRU1_ETH0_RESETh	Output	EXT PU
MCASP1_AXR5	GPIO5_7	F13	GPIO_PRU1_ETH1_RESETh	Output	EXT PU
MCASP1_AXR6	GPIO5_8	C12	GPIO_PRU2_ETH0_RESETh	Output	EXT PU
MCASP1_AXR7	GPIO5_9	D12	GPIO_PRU2_ETH1_RESETh	Output	EXT PU
GPIO6_14	GPIO6_14	E21	CAM_ENn	Output	PU/PD on camera board
GPIO6_15	GPIO6_15	F20	GPIO_TOUCH_RESETh	Output	EXT PU
GPIO6_16	GPIO6_16	F21	PMIC_INT	Input	INT PU
XREF_CLK2	GPIO6_19	B26	AM57XX_INDEETHER_LED0_RED	Output	EXT PD
MCASP2_AXR5	GPIO6_7	B16	AM57XX_INDEETHER_LED1_RED	Output	EXT PD
SPI1_CS0	GPIO7_10	A24	AM57XX_INDEETHER_LED2_YEL	Output	EXT PD
SPI1_CS1	GPIO7_11	A22	AM57XX_INDEETHER_LED3_RED	Output	EXT PD
UART1_RXD	GPIO7_22	B27	AM57XX_STATUSLED1_YEL	Output	EXT PD
UART1_TXD	GPIO7_23	C26	AM57XX_STATUSLED1_GRN	Output	EXT PD
SPI1_SCLK	GPIO7_7	A25	AM572X_HAPTICS_TRIG	Output	EXT PD
SPI1_D1	GPIO7_8	F16	AM57XX_INDEETHER_LED2_GRN	Output	EXT PD
SPI1_D0	GPIO7_9	B25	AM57XX_INDEETHER_LED2_RED	Output	EXT PD

13 Board Connectors

This section shows the pin-outs for the connectors on the AM574x IDK EVM.

Table 6. Expansion Connector - J21

Pin	Signal Name	Secondary Signal Name
1	V3_3D	—
2	V5_0D	—
3	PR1_EDC_LATCH0	—
4	GPMC_CS0	—
5	PR1_EDC_SYNC0	—
6	GPMC_CS3	—
7	No Connect	—
8	GPMC_ADV_N_ALE	—
9	No Connect	AM57XX_PRU1ETH1_TXCLK
10	GPMC_OEN_REN	—
11	No Connect	AM57XX_PRU1ETH1_TXD3
12	GPMC_WEN	—
13	PR2_EDC_LATCH0	AM57XX_PRU1ETH_MDCLK
14	GPMC_BEN0	—
15	PR2_EDC_LATCH1	PRU1ETH1_TXD1
16	GPMC_BEN1	—
17	PR2_EDC_SYNC0	PRU1ETH1_RXCLK
18	No Connect	—
19	PR2_EDC_SYNC1	PRU1ETH1_RXD3
20	No Connect	—
21	No Connect	PRU1ETH1_RXD1
22	DGND	—
23	No Connect	PRU1ETH1_RXERR
24	SPI2_SCLK	—
25	SYS_RESETn	—
26	SPI2_DIN	—
27	IND_I2C_SCL	—
28	SPI2_DOOUT	—
29	IND_I2C_SDA	—
30	SPI2_CS0n	—
31	AM57XX_GPMC_AD0	—
32	AM57XX_GPMC_AD8	—
33	AM57XX_GPMC_AD1	—
34	AM57XX_GPMC_AD9	—
35	AM57XX_GPMC_AD2	—
36	AM57XX_GPMC_AD10	—
37	AM57XX_GPMC_AD3	—
38	AM57XX_GPMC_AD11	—
39	DGND	—
40	DGND	—
41	CAN1_RXDF	—
42	AM57XX_GPMC_AD12	—
43	CAN1_TXDF	—
44	AM57XX_GPMC_AD13	—

Table 6. Expansion Connector - J21 (continued)

Pin	Signal Name	Secondary Signal Name
45	AM57XX_PR1_UART0_TXD	—
46	AM57XX_GPMC_AD14	—
47	AM57XX_PR1_UART0_RXD	—
48	AM57XX_GPMC_AD15	—
49	AM57XX_PR2_PROFI_TXEN	—
50	HDQ	—
51	AM57XX_GPMC_AD4	—
52	GPMC_WAIT0	—
53	AM57XX_GPMC_AD5	—
54	PR2_UART0_RXD	—
55	AM57XX_GPMC_AD6	—
56	PR2_UART0_TXD	—
57	AM57XX_GPMC_AD7	—
58	GPMC_CLK	—
59	DGND	—
60	DGND	—

Table 7. I/O Expansion Header Connector - J37

Pin	Signal Name
1	INDUS_INPUT0
2	V12_0D
3	INDUS_INPUT1
4	V12_0D
5	INDUS_INPUT2
6	V12_0D
7	INDUS_INPUT3
8	V12_0D
9	INDUS_INPUT4
10	V12_0D
11	INDUS_INPUT5
12	V12_0D
13	INDUS_INPUT6
14	V12_0D
15	INDUS_INPUT7
16	V12_0D
17	DGND
18	No Connect
19	DRAIN0
20	DRAIN1
21	DRAIN2
22	DRAIN3
23	DRAIN4
24	DRAIN5
25	DRAIN6
26	DRAIN7
27	V5_0D
28	V5_0D
29	DGND
30	DGND

Table 8. MicroSD Connector - J15

Pin	Pin Name	Signal Name
1	DAT2	MMC_D2
2	DAT3	MMC_D3
3	CMD	MMC_CMD
4	VDD	V3_3D
5	CLOCK	MMC_CLK
6	DGND	VSS
7	DAT0	MMC_D0
8	DAT1	MMC_D1
9	GND	DGND
10	CD	MMC1_SDCD
11	GND3	DGND
12	GND4	DGND
13	GND5	DGND
14	GND6	DGND
15	GND7	DGND
16	GND8	DGND

Table 9. Power Jack Connector - J1

Pin	Signal Name
1	VPWRIN_JCK
2	DGND
3	DGND

Table 10. Power Terminal Block Connector - J2

Pin	Signal Name
1	VPWRIN_JCK
2	DGND

Table 11. PRU1ETH0 RJ45 Connector - J3

Pin	Pin Name	Signal Name
1	RD+	PRU1ETHER0_RDP
2	RD-	PRU1ETHER0_RDN
3	RCT	V3_3D
4	TCT	V3_3D
5	TD+	PRU1ETHER0_TDP
6	TD-	PRU1ETHER0_TDN
7	N/C	No connect
8	AC GND	DGND
9	YEL LED Anode	V3_3D
10	YEL LED Cathode	RXLINK
11	GRN LED Anode	V3_3D
12	GRN LED Cathode	PRU1ETH0_LINKLED
SHLD1	Shield	AGNDFRAME_PRU1ETH0
SHLD2	Shield	AGNDFRAME_PRU1ETH0

Table 12. PRU1ETH1 RJ45 Connector - J5

Pin	Pin Name	Signal Name
1	RD+	PRU1ETHER1_RDP
2	RD-	PRU1ETHER1_RDN
3	RCT	V3_3D
4	TCT	V3_3D
5	TD+	PRU1ETHER1_TDP
6	TD-	PRU1ETHER1_TDN
7	N/C	No connect
8	AC GND	DGND
9	YEL LED Anode	V3_3D
10	YEL LED Cathode	RXLINK
11	GRN LED Anode	V3_3D
12	GRN LED Cathode	PRU1ETH1_LINKLED
SHLD1	Shield	AGNDFRAME_PRU1ETH1
SHLD2	Shield	AGNDFRAME_PRU1ETH1

Table 13. PRU2ETH0 RJ45 Connector - J6

Pin	Pin Name	Signal Name
1	RD+	PRU2ETHER0_RDP
2	RD-	PRU2ETHER0_RDN
3	RCT	V3_3D
4	TCT	V3_3D
5	TD+	PRU2ETHER0_TDP
6	TD-	PRU2ETHER0_TDN
7	N/C	No connect
8	AC GND	DGND
9	YEL LED Anode	V3_3D
10	YEL LED Cathode	RXLINK
11	GRN LED Anode	V3_3D
12	GRN LED Cathode	PRU2ETH0_LINKLED
SHLD1	Shield	AGNDFRAME_PRU2ETH0
SHLD2	Shield	AGNDFRAME_PRU2ETH0

Table 14. PRU2ETH1 RJ45 Connector - J8

Pin	Pin Name	Signal Name
1	RD+	PRU2ETHER1_RDP
2	RD-	PRU2ETHER1_RDN
3	RCT	V3_3D
4	TCT	V3_3D
5	TD+	PRU2ETHER1_TDP
6	TD-	PRU2ETHER1_TDN
7	N/C	No connect
8	AC GND	DGND
9	YEL LED Anode	V3_3D
10	YEL LED Cathode	RXLINK
11	GRN LED Anode	V3_3D
12	GRN LED Cathode	PRU2ETH1_LINKLED
SHLD1	Shield	AGNDFRAME_PRU2ETH1
SHLD2	Shield	AGNDFRAME_PRU2ETH1

Table 15. PRU2ETH0 Test Header Connector - J7

Pin	Signal Name	Net Name
1	RT2_MII0_TXEN	AM57XX_PRU2ETH0_TXEN
2	RT2_MII0_RXDV	AM57XX_PRU2ETH0_RXDV
3	RT2_MII0_EDIO_DATA0	AM57XX_VIN2A_VSYNC0
4	RT2_MII0_EDIO_DATA1	AM57XX_PR1_UART0_TXD
5	DGND	—

Table 16. PRU2ETH1 Test Header Connector - J4

Pin	Signal Name	Net Name
1	RT2_MII1_TXEN	PRU2ETH1_TXEN
2	RT2_MII1_RXDV	PRU2ETH1_RXDV
3	RT2_MII1_EDIO_DATA0	AM57XX_VIN2A_HSYNC0
4	RT2_MII1_EDIO_DATA1	AM57XX_VIN2A_DE0
5	DGND	DGND

Table 17. Camera Connector - J9

Pin	Pin Name	Signal Name
1	Power	VMAIN
2	CAM1_VSYNC	DGND
3	CAM1_DATA0	AM572X_VIN4B_DATA0
4	CAM1_HSYNC	AM572X_VIN4B_HSYNC
5	CAM1_DATA1	AM572X_VIN4B_DATA1
6	CAM1_DATA6	AM572X_VIN4B_DATA6
7	CAM1_DATA2	AM572X_VIN4B_DATA2
8	CAM1_DATA7	AM572X_VIN4B_DATA7
9	CAM1_PCLK	AM572X_VIN4B_PCLK
10	No Connect	—
11	GND	DGND
12	GND	DGND
13	CAM1_DATA3	AM572X_VIN4B_DATA3
14	No Connect	—
15	CAM1_DATA4	AM572X_VIN4B_DATA4
16	CAM1_GIO0	PU to V3_3D
17	CAM1_WEN	AM572X_VIN4B_DATA5
18	CAM1_GIO1	CAM_ENn
19	CAM1_DATA5	AM572X_VIN4B_DE
20	CAM1_FIELD	AM572X_VIN4B_FLD
21	GND	DGND
22	I2C_SCL	IND_I2C_SCL
23	Clock	20.000 MHz Osc Out
24	I2C_SDA	IND_I2C_SDA

Table 18. GigE RJ45 Connector - J10

Pin	Pin Name	Signal Name
1	CH-GND	DGND
2	VCC	No connect
3	MX3+	ETHER0_D3P
4	MX3-	ETHER0_D3N
5	MX2+	ETHER0_D2P
6	MX2-	ETHER0_D2N
7	MX1+	ETHER0_D1P
8	MX1-	ETHER0_D1N
9	MX0+	ETHER0_D0P
10	MX0-	ETHER0_D0N
11	RT GRN Anode	PU to PHY0_LED_ACTn
12	RT YEL Anode	DGND
13	LEFT GRN Anode	DGND
14	LEFT YEL Anode	PU to PHY0_LED_LINKn
SHLD1	Shield	AGND_GBETH0
SHLD2	Shield	AGND_GBETH0

Table 19. GigE RJ45 Connector - J12

Pin	Pin Name	Signal Name
1	CH-GND	DGND
2	VCC	No connect
3	MX3+	ETHER1_D3P
4	MX3-	ETHER1_D3N
5	MX2+	ETHER1_D2P
6	MX2-	ETHER1_D2N
7	MX1+	ETHER1_D1P
8	MX1-	ETHER1_D1N
9	MX0+	ETHER1_D0P
10	MX0-	ETHER1_D0N
11	RT GRN Anode	PU to PHY1_LED_ACTn
12	RT YEL Anode	DGND
13	LEFT GRN Anode	DGND
14	LEFT YEL Anode	PU to PHY1_LED_LINKn
SHLD1	Shield	AGND_GBETH1
SHLD2	Shield	AGND_GBETH1

Table 20. LCD Module FFC Connector - J16

Pin	Pin Name	Signal Name
1	—	No Connect
2	—	No Connect
3	VCC	V3_7LCD
4	VCC	V3_7LCD
5	VCC	V3_7LCD
6	—	No Connect
7	GND	DGND
8	MIPI_LN3_N	LCD_MIPI3N
9	MIPI_LN3_P	LCD_MIPI3P
10	GND	DGND
11	MIPI_LN2_N	LCD_MIPI2N
12	MIPI_LN2_P	LCD_MIPI2P
13	GND	DGND
14	MIPI_LN1_N	LCD_MIPI1N
15	MIPI_LN1_P	LCD_MIPI1P
16	GND	DGND
17	MIPI_LN0_N	LCD_MIPI0N
18	MIPI_LN0_P	LCD_MIPI0P
19	GND	DGND
20	MIPI_CLK_N	LCD_CLKN
21	MIPI_CLK_P	LCD_CLKP
22	GND	DGND
23	LED_CATHODE	VLED-
24	LED_CATHODE	VLED-
25	LED_CATHODE	VLED-
26	LED_CATHODE	VLED-
27	LED_CATHODE	VLED-
28	LED_CATHODE	VLED-
29	LED Anode Supply	VLED+
30	LED Anode Supply	VLED+
31	—	No Connect
32	—	No Connect

Table 21. Touchscreen Controller FFC Connector - J17

Pin	Pin Name	Signal Name
1	SDA	IND_I2C_SDA
2	SCL	IND_I2C_SCL
3	TSC_RESETn	GPIO_TOUCH_RESETn
4	TSC_INT	TOUCH_INT
5	V+	V3_3D
6	GND	DGND

Table 22. HDMI Standard A-type Connector - J24

Pin	Pin Name	Signal Name
1	DAT2+	HDMI_TX2+
2	DAT2_S	DGND
3	DAT2-	HDMI_TX2-
4	DAT1+	HDMI_TX1+
5	DAT1_S	DGND
6	DAT1-	HDMI_TX1-
7	DAT0+	HDMI_TX0+
8	DAT0_S	DGND
9	DAT0-	HDMI_TX0-
10	CLK+	HDMI_CLK+
11	CLK_S	DGND
12	CLK-	HDMI_CLK-
13	CEC	HDMICONN_CEC
14	NC	No Connect
15	SCL	HDMICONN_I2CSCL
16	SDA	HDMICONN_I2CSDA
17	DDC/CEC GND	DGND
18	+5V	V5_0HDMICONN
19	HPLG	HDMICONN_HPLG
MTG1	Shield	DGND
MTG2	Shield	DGND
MTG3	Shield	DGND
MTG4	Shield	DGND

Table 23. MIPI-60 JTAG Connector - J18

Pin	Pin Name	Signal Name
1	VREF_DBG	PU to V3_3D
2	TMS	JTAG_TMS
3	TCK	JTAG_TCK
4	TDO	JTAG_TDO
5	TDI	JTAG_TDI
6	RESETn	EMU_RSTn
7	RTCK	AM57XX_RTCK
8	TRSTPD	JTAG_TRSTn
9	TRSTn	No Connect
10	EXTE	No Connect
11	EXTF	No Connect
12	VREF_TR	PU to V3_3D
13	TR_CLK0	EMU2
14	TR_CLK1	No Connect
15	TGT_DETECT	DGND
16	GND	DGND
17	TRD0.0	EMU3
18	TRD1.0	No Connect

Table 23. MIPI-60 JTAG Connector - J18 (continued)

Pin	Pin Name	Signal Name
19	TRD0.1	JTAG_EMU0
20	TRD1.1	No Connect
21	TRD0.2	JTAG_EMU1
22	TRD1.2	No Connect
23	TRD0.3	EMU4
24	TRD1.3	No Connect
25	TRD0.4	EMU5
26	TRD1.4	No Connect
27	TRD0.5	EMU6
28	TRD1.5	No Connect
29	TRD0.6	EMU7
30	TRD1.6	No Connect
31	TRD0.7	EMU8
32	TRD1.7	No Connect
33	TRD0.8	EMU9
34	TRD1.8	No Connect
35	TRD0.9	EMU10
36	TRD1.9	No Connect
37	TRD3.0	EMU11
38	TRD2.0	No Connect
39	TRD3.1	EMU12
40	TRD2.1	No Connect
41	TRD3.2	EMU13
42	TRD2.2	No Connect
43	TRD3.3	EMU14
44	TRD2.3	No Connect
45	TRD3.4	EMU15
46	TRD2.4	No Connect
47	TRD3.5	EMU16
48	TRD2.5	No Connect
49	TRD3.6	EMU17
50	TRD2.6	No Connect
51	TRD3.7	EMU18
52	TRD2.7	No Connect
53	TRD3.8	EMU19
54	TRD2.8	No Connect
55	TRD3.9	No Connect
56	TRD2.9	No Connect
57	GND	DGND
58	GND	DGND
59	TR_CLK3	No Connect
60	TR_CLK2	No Connect
61	GND	DGND
62	GND	DGND
63	GND	DGND
64	GND	DGND

Table 24. JTAG USB Micro-AB Connector - J19

Pin	Pin Name	Signal Name
1	VBUS	VUSB_JTAG
2	DM	EMU_USB_DM
3	DP	EMU_USB_DP
4	ID	No Connect
5	GND	DGND
S1	S1	GNDUSBJ
S2	S2	GNDUSBJ
S3	S3	GNDUSBJ
S4	S4	GNDUSBJ

Table 25. USB Port 1 USB3.0 Standard A-type Connector - J23

Pin	Pin Name	Signal Name
1	VBUS	VUSB_VBUS1
2	DM	USB1_CONN_DM
3	DP	USB1_CONN_DP
4	GND	DGND
5	STDA_SSRX-	USB1_3_0_STDA_SSRX-
6	STDA_SSRX+	USB1_3_0_STDA_SSRX+
7	GND_DRAIN	DGND
8	STDA_SSTX-	USB1_3_0_STDA_SSTX-
9	STDA_SSTX+	USB1_3_0_STDA_SSTX+
S1	S1	GNDUSB1
S2	S2	GNDUSB1

Table 26. USB Port 2 USB2.1 Micro-AB Connector - J45

Pin	Pin Name	Signal Name
1	VBUS	VUSB_VBUS2
2	DM	USB2_CONN_DM
3	DP	USB2_CONN_DP
4	ID	USB2_ID
5	GND	DGND
S1	S1	GNDUSB2
S2	S2	GNDUSB2
S3	S3	GNDUSB2
S4	S4	GNDUSB2

Table 27. CAN Header Connector - J38

Pin	Signal Name
1	VCAN1
2	CAN1_H
3	CAN1_L
4	GND_CAN1
5	No Connect

Table 28. Profibus DB9F Connector - J14

Pin	Signal Name
1	No Connect
2	No Connect
3	PROFIBUS_A
4	No Connect
5	GND_PROFI
6	VPROFI
7	No Connect
8	PROFIBUS_B
9	No Connect

Table 29. RS-485 Header Connector - J39

Pin	Signal Name
1	RS485_A
2	RS485_B
3	DGND

Table 30. PCIe Connector – J22

Pin	Pin Nmae	Signal Name
B1	+12 V	V12_0D
B2	+12 V	V12_0D
B3	+12 V	V12_0D
B4	Ground	DGND
B5	SMCLK	PCIE_SMB_CLK
B6	SMDAT	PCIE_SMB_DATA
B7	Ground	DGND
B8	+3.3V	V3_3D
B9	TRST#	PCIE_TRSTn
B10	+3.3V AUX	V3_3AUX_PCIE
B11	WAKE#	PCIE_WAKEn
B12	CLKREQ#	No Connect
B13	Ground	DGND
B14	HSOp(0)	PCIECONN_PETp0
B15	HSOn(0)	PCIECONN_PETn0
B16	Ground	DGND
B17	PRSNT2#	DGND
B18	Ground	DGND
A1	PRSNT1#	PCIE_CRDPRESENT
A2	+12 V	V12_0D
A3	+12 V	V12_0D
A4	Ground	DGND
A5	TCK	PD to DGND
A6	TDI	PU to V3_3D
A7	TDO	TP20
A8	TMS	PU to V3_3D
A9	+3.3V	V3_3D
A10	+3.3V	V3_3D
A11	PERST#	PCIE_PERSTn
A12	Ground	DGND
A13	REFCLK+	PCIE_REFCLKP
A14	REFCLK-	PCIE_REFCLKN
A15	Ground	DGND
A16	HSIp(0)	PCIE_PERp0
A17	HSIn(0)	PCIE_PERn0
A18	Ground	DGND

14 EVM Important Notice

Refer to the [STANDARD TERMS AND CONDITIONS FOR EVALUATION MODULES \(SSZZ027\)](#).

Known Deficiencies in AM574x IDK EVM

A.1 Power solution not sufficient for full PCIe plug-in card compliance

The AM574x IDK EVM supports compatibility to PCIe x1 plug-in cards. It is not compliant with the PCIe Card Electro-Mechanical (CEM) specification. Specifically, the board does not provide the recommended power per the CEM. It provides up to 0.5A of current on the 3.3V/3.3V_AUX input pins and up to 0.5A on the 12V input pins. Also, the root complex design implemented does not support hot plug-in of cards.

A.2 AM574x IDK EVM does not support eMMC HS200 mode

The interface voltage for the eMMC is fixed at 3.3V in all modes of operation. This prevents support of HS200 which requires a transition to 1.8V. The AM574x IDK EVM does support this voltage shift for the SDCARD attached to the MMC1 port. The MMC1 port is on VDDSHV8 supply that is attached to the LDO1 PMIC output that supports this voltage shift for higher speed modes. The eMMC is attached to the VDDSHV11 supply fixed at 3.3V. Board designs that require HS200 support for eMMC would need a solution to transition from 3.3V to 1.8V under software control.

A.3 PCIe PERSTn line not in proper state at start-up

The board does not contain pull-up or pull-down resistors to allow this line to be pulled-high at start-up. This can cause PCIe link training to fail. Future software releases need to properly control the GPIO output pins to enable this correctly at start-up.

A.4 EDIO connectors J4 and J7 should support real-time debugging for both PRU1 and PRU2

The pins chosen provide visibility to the PRU2 MII0 and MII1 ports and PRU1 EDIO ports.

A.5 HDQ implementation not correct

HDQ was intended to be attached to the Expansion Connector. Since this pin is multiplexed with XREF_CLK3/CLKOUT3 used with the Camera connector, the clock options implemented for the camera connector prevent use of HDQ without addition of a wire. This can be enabled by adding a wire between the open pads of R905 and R300.

A.6 Removing the power plug and inserting it again while the power supply is energized may cause damage

Removing the power plug and inserting it again while the power supply is energized may damage the AM574x IDK EVM and/or other devices attached to the board such as emulators that provide an alternate path to ground. Removal of AC power from the external power supply is a safer method, if required. It is also recommended that the external power supply have the common return bonded to earth ground. If this is not possible, a separate connection from the board ground to earth ground may need to be provided. Test fixtures that repeatedly cycle main power on and off should have the board ground bonded to earth ground at all times during this testing.

A.7 Software shutdown of PMIC not operational

The PMIC is implemented to support PORz generation whenever any reset is initiated within the AM5748 SOC. This is enabled by pulling PMIC BOOT1 to VRTC. This has the side effect of requiring that PMIC GPIO7/POWERHOLD also be pulled high. This results in an “always on” design that cannot be shut-off by software. An external PORz pulse generator like that implemented on the X15 GP EVM would need to be used to enable this feature. Please refer to i862 in the errata document for more information.

A.8 PMIC implementation does not support required SOC shut-down sequence

The AM5748 SOC requires that its supplies are sequenced on and off in the correct sequence to maintain the reliability as stated in the [AM574x Sitara Processors Silicon Revision 1.0 Data Manual \(SPRS982\)](#). The PMIC can enforce this start-up and also the shut-down sequence if the PMIC RESET_IN is driven low at least 1.1ms before the main supply to the PMIC collapses. However, the AM574x IDK EVM design does not contain a circuit for this. Please refer to the AM571 IDK EVM design (v1.3 or later) for an example of the required circuitry.

A.9 USB port providing UART console and XDS100 emulation not isolated from EVM board supplies

Whenever the EVM power supplies are cycled, the USB connection supporting the UART console and XDS100 emulation also drops. Since this port takes time to enumerate after power is restored, initial console output can be lost. Also, this results in power leakage from the USB VBUS back into the EVM when it is not powered. Please refer to the AM571 IDK EVM design (v1.3 or later) for an example of the required circuitry that will allow the USB bridge to remain properly powered and isolated from the EVM to prevent these negative affects.

A.10 Need 47- μ F capacitor at camera header

Some camera video input instability has been seen. The solution for this is addition of a 47 μ F capacitor at the supply pin for the camera header. This has been implemented on the AM571x IDK EVM v1.3 and later.

A.11 Decoupling capacitors do not reflect AM574x PDN recommendations

Decoupling capacitors do not reflect AM574x PDN recommendations per [Sitara Processor Power Distribution Networks: Implementation and Analysis \(SPRAC76\)](#)

These were corrected in the latest version of the AM571x IDK EVM. Please refer to the AM571 IDK EVM design (v1.3 or later) for an example of the required circuitry.

A.12 CCS System Reset fails

Warm reset and emulation reset events configured for warm reset cause the Texas Instruments Code Composer Studio™ (CCS) integrated development environment (IDE) to issue an error message. This is due to the reset erratum that requires all resets to trigger a PORz low event. Since this is not expected by CCS when it initiates a warm reset, it loses its context and issues an error. Newer versions of CCS handle this event better but an error message will always be generated.

A.13 AM574x IDK EVM design contains 2 clamp circuits that may not be necessary

During early investigation of power shut-down sequencing, it was determined that clamps were required on every 3.3V supply to the dual-voltage I/O cell supplies (VDDSHVx). This would enforce the requirement shown in Figure 5-3 of the [AM574x Sitara Processors Silicon Revision 1.0 Data Manual \(SPRS982\)](#) that states that the 3.3V supply inputs must never be more than 2.0V above the VDD518V supply, even during ramping up or ramping down. The AM574x IDK EVM design contains these clamp circuits on both V3_3D, that powers almost all VDDSHVx supplies, and VSDMMC, that powers VDDSHV8 used with the SDCARD on MMC1. Later it was determined that the only method to maintain device reliability was to fully enforce the supply sequence requirements shown in Figures 5-1 and 5-2 of the [AM574x Sitara Processors Silicon Revision 1.0 Data Manual \(SPRS982\)](#). The companion PMIC, TPS6590379, was enhanced to provide a shortened shut-down sequence that enforces the DM requirements in a time period (~1ms) that the PMIC input can hold up the supplies. The PMIC also has supply discharge resistors to pull down the supplies quickly when they are turning off. These 2 capabilities in the companion PMIC make the clamp circuits superfluous. However, designs that use REGEN1 to power the VDDSHVx supplies through a power switch will still need the clamp circuit. The power switches available do not discharge the supplies quick enough.

A.14 Crystal connected to osc0 needs to have 50 ppm or better long term accuracy

The crystal connected to osc0 needs to have 50ppm or better long term accuracy since it generates clocks used for Ethernet interfaces. The current crystal has 30ppm accuracy and 50ppm temperature variation for a combined tolerance of 80ppm. It also has aging of 2ppm per year.

A.15 Software must program the CDCE913 for 0-pf load capacitance

Software must program the CDCE913 for 0pf load capacitance to allow crystals to operate at their target frequency. Crystal load capacitors can be added to the oscillator circuit to allow the generated clock to output at the required nominal frequency so that this programming is not required. The default capacitance within the CDCE913 is 10pF so the capacitors C172, C173, C193, and C194 should be 8pF. Please refer to the [CDCE\(L\)913: Flexible Low Power LVCMOS Clock Generator With SSC Support for EMI Reduction Data Manual \(SCAS849\)](#) for more information. Also note that these clock generators are used to drive the Ethernet circuitry, so the same crystal accuracy requirement from [Section A.14](#) applies to these crystals as well.

A.16 PHY address LSB for U9 and U15 can be latched incorrectly

The PHY address LSB for U9 and U15 gets determined by the signal level at the PHY's COL pin during reset release. The PHY has a pull-down resistor connected to this pin to enable latching the value of 0. Unfortunately, this pin is also connected to one of the RJ-45 connector LEDs that pulls the signal to an undefined voltage of about 1.4V during the reset time. Therefore, the PHY address can incorrectly latch a value of 1. The LED circuit should be configured for active-high indication and the connections to the LED reversed with the cathode connected to ground. This allows the LSB of the address to be properly latched. Please refer to Section 6 of the [TLK1XX Design and Layout Guide Application Report \(SLVA531\)](#) for more information. The current software workaround programs the RXLINK pin with a pull-down resistor and then pulses the PHY reset from a GPIO, to cause it to latch the PHY address correctly.

IMPORTANT NOTICE FOR TI DESIGN INFORMATION AND RESOURCES

Texas Instruments Incorporated ("TI") technical, application or other design advice, services or information, including, but not limited to, reference designs and materials relating to evaluation modules, (collectively, "TI Resources") are intended to assist designers who are developing applications that incorporate TI products; by downloading, accessing or using any particular TI Resource in any way, you (individually or, if you are acting on behalf of a company, your company) agree to use it solely for this purpose and subject to the terms of this Notice.

TI's provision of TI Resources does not expand or otherwise alter TI's applicable published warranties or warranty disclaimers for TI products, and no additional obligations or liabilities arise from TI providing such TI Resources. TI reserves the right to make corrections, enhancements, improvements and other changes to its TI Resources.

You understand and agree that you remain responsible for using your independent analysis, evaluation and judgment in designing your applications and that you have full and exclusive responsibility to assure the safety of your applications and compliance of your applications (and of all TI products used in or for your applications) with all applicable regulations, laws and other applicable requirements. You represent that, with respect to your applications, you have all the necessary expertise to create and implement safeguards that (1) anticipate dangerous consequences of failures, (2) monitor failures and their consequences, and (3) lessen the likelihood of failures that might cause harm and take appropriate actions. You agree that prior to using or distributing any applications that include TI products, you will thoroughly test such applications and the functionality of such TI products as used in such applications. TI has not conducted any testing other than that specifically described in the published documentation for a particular TI Resource.

You are authorized to use, copy and modify any individual TI Resource only in connection with the development of applications that include the TI product(s) identified in such TI Resource. NO OTHER LICENSE, EXPRESS OR IMPLIED, BY ESTOPPEL OR OTHERWISE TO ANY OTHER TI INTELLECTUAL PROPERTY RIGHT, AND NO LICENSE TO ANY TECHNOLOGY OR INTELLECTUAL PROPERTY RIGHT OF TI OR ANY THIRD PARTY IS GRANTED HEREIN, including but not limited to any patent right, copyright, mask work right, or other intellectual property right relating to any combination, machine, or process in which TI products or services are used. Information regarding or referencing third-party products or services does not constitute a license to use such products or services, or a warranty or endorsement thereof. Use of TI Resources may require a license from a third party under the patents or other intellectual property of the third party, or a license from TI under the patents or other intellectual property of TI.

TI RESOURCES ARE PROVIDED "AS IS" AND WITH ALL FAULTS. TI DISCLAIMS ALL OTHER WARRANTIES OR REPRESENTATIONS, EXPRESS OR IMPLIED, REGARDING TI RESOURCES OR USE THEREOF, INCLUDING BUT NOT LIMITED TO ACCURACY OR COMPLETENESS, TITLE, ANY EPIDEMIC FAILURE WARRANTY AND ANY IMPLIED WARRANTIES OF MERCHANTABILITY, FITNESS FOR A PARTICULAR PURPOSE, AND NON-INFRINGEMENT OF ANY THIRD PARTY INTELLECTUAL PROPERTY RIGHTS.

TI SHALL NOT BE LIABLE FOR AND SHALL NOT DEFEND OR INDEMNIFY YOU AGAINST ANY CLAIM, INCLUDING BUT NOT LIMITED TO ANY INFRINGEMENT CLAIM THAT RELATES TO OR IS BASED ON ANY COMBINATION OF PRODUCTS EVEN IF DESCRIBED IN TI RESOURCES OR OTHERWISE. IN NO EVENT SHALL TI BE LIABLE FOR ANY ACTUAL, DIRECT, SPECIAL, COLLATERAL, INDIRECT, PUNITIVE, INCIDENTAL, CONSEQUENTIAL OR EXEMPLARY DAMAGES IN CONNECTION WITH OR ARISING OUT OF TI RESOURCES OR USE THEREOF, AND REGARDLESS OF WHETHER TI HAS BEEN ADVISED OF THE POSSIBILITY OF SUCH DAMAGES.

You agree to fully indemnify TI and its representatives against any damages, costs, losses, and/or liabilities arising out of your non-compliance with the terms and provisions of this Notice.

This Notice applies to TI Resources. Additional terms apply to the use and purchase of certain types of materials, TI products and services. These include; without limitation, TI's standard terms for semiconductor products (<http://www.ti.com/sc/docs/stdterms.htm>), [evaluation modules](#), and [samples](http://www.ti.com/sc/docs/sampterm.htm) (<http://www.ti.com/sc/docs/sampterm.htm>).

Mailing Address: Texas Instruments, Post Office Box 655303, Dallas, Texas 75265
Copyright © 2018, Texas Instruments Incorporated

Looking for pricing, stock, or lifecycle information?

Click below to explore more details on WIN SOURCE:

 [View TMDSIDK574](#) on WIN SOURCE

 [Texas Instruments](#) Information

Optimize Your Supply Chain with WIN SOURCE Solutions

-  Global Sourcing Solution
-  Obsolete Management
-  Cost Control Management
-  Shortage Management
-  Alternative Solution
-  Excess Inventory Management