



**THE DATASHEET OF
LM3218SEX/NOPB**



LM3218 650 mA Miniature, Adjustable, Step-Down DC-DC Converter for RF Power Amplifiers

Check for Samples: [LM3218](#)

FEATURES

- Includes 2.6 μH Inductor in Very Small Form Factor (3mm x 2.5mm x 1.2mm)
- 2 MHz (typ.) PWM Switching Frequency
- Operates from a Single Li-Ion Cell (2.7V to 5.5V)
- Adjustable Output Voltage (0.8V to 3.6V)
- Fast Output Voltage Transient (0.8V to 3.4V in 25 μs typ.)
- 650 mA Maximum Load Capability
- High Efficiency (95% typ. at 3.9 V_{IN} , 3.4 V_{OUT} at 400 mA)
- 8-pin POS Package
- Current Overload Protection
- Thermal Overload Protection

APPLICATIONS

- Cellular Phones
- Hand-Held Radios
- RF PC Cards
- Battery-Powered RF Devices

TYPICAL APPLICATION

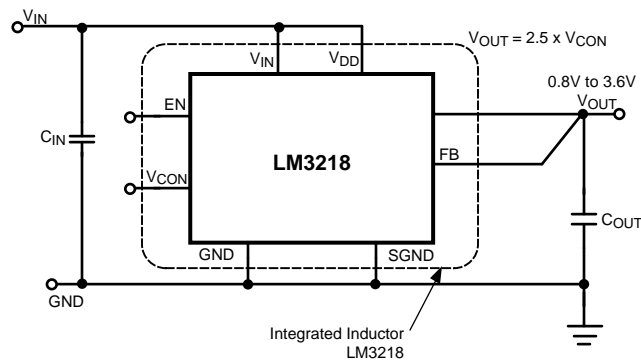
Figure 1. LM3218 Typical Application

DESCRIPTION

The LM3218 is a DC-DC converter with inductor which is optimized for powering RF power amplifiers (PAs) from a single Lithium-Ion cell. It steps down an input voltage in the range from 2.7V to 5.5V to an adjustable output voltage of 0.8V to 3.6V. Output voltage is set by using a V_{CON} analog input to control power levels and efficiency of the RF PA.

The LM3218 offers superior electrical performance for mobile phones and similar RF PA applications with a reduced footprint (3mm x 2.5mm x 1.2mm). Fixed-frequency PWM operation minimizes RF interference. A shutdown function turns the device off and reduces battery consumption to 0.01 μA (typ.).

The LM3218 is available in an integrated inductor 8-pin POS package. A high switching frequency (2 MHz typ.) allows use of tiny surface-mount components. Only two small external surface-mount components, two ceramic capacitors, are required. The overall board space is reduced up to 25% from the typical discrete inductor solution.



Please be aware that an important notice concerning availability, standard warranty, and use in critical applications of Texas Instruments semiconductor products and disclaimers thereto appears at the end of this data sheet.

All trademarks are the property of their respective owners.



These devices have limited built-in ESD protection. The leads should be shorted together or the device placed in conductive foam during storage or handling to prevent electrostatic damage to the MOS gates.

CONNECTION DIAGRAM

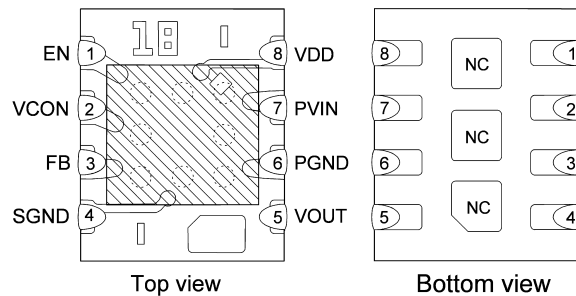

Figure 2. Package Number NQA0008A

PIN DESCRIPTIONS

Pin #	Name	Description
1	EN	Enable Input. Set this digital input high for normal operation. For shutdown, set low.
2	V _{CON}	Voltage Control Analog input. V _{CON} controls V _{OUT} in PWM mode.
3	FB	Feedback Analog Input. Connect to the V _{OUT} pin.
4	SGND	Analog and Control Ground.
5	V _{OUT}	Output Voltage, connects to one terminal of 2.6 μH inductor. Connect output filter capacitor C2 to get DC voltage out.
6	PGND	Power Ground
7	PV _{IN}	Power Supply Voltage Input to the internal Buck PFET switch.
8	V _{DD}	Analog Supply Input.

ABSOLUTE MAXIMUM RATINGS⁽¹⁾⁽²⁾⁽³⁾

V_{DD} , PV_{IN} to SGND		-0.2V to +6.0V
PGND to SGND		-0.2V to +0.2V
EN, FB, V_{CON}		(SGND -0.2V) to (V_{DD} +0.2V) w/6.0V max
V_{OUT}		(PGND -0.2V) to (PV_{IN} +0.2V) w/6.0V max
PV_{IN} to V_{DD}		-0.2V to +0.2V
Continuous Power Dissipation ⁽⁴⁾		Internally Limited
Junction Temperature (T_{J-MAX})		+150°C
Storage Temperature Range		-65°C to +150°C
Maximum Lead Temperature (Soldering, 10 sec.)		+260°C
ESD Rating ⁽⁵⁾⁽⁶⁾	Human Body Model:	2000V
	Machine Model:	200V

- (1) Absolute Maximum Ratings indicate limits beyond which damage to the component may occur. Operating Ratings are conditions under which operation of the device is ensured. Operating Ratings do not imply specified performance limits. For specified performance limits and associated test conditions, see the Electrical Characteristics tables.
- (2) All voltages are with respect to the potential at the GND pins. The LM3218 is designed for mobile phone applications where turn-on after power-up is controlled by the system controller and where requirements for a small package size overrule increased die size for internal Under Voltage Lock-Out (UVLO) circuitry. Thus, it should be kept in shutdown by holding the EN pin low until the input voltage exceeds 2.7V.
- (3) If Military/Aerospace specified devices are required, please contact the TI Sales Office/Distributors for availability and specifications.
- (4) Internal thermal shutdown circuitry protects the device from permanent damage. Thermal shutdown engages at $T_J = 150^\circ\text{C}$ (typ.) and disengages at $T_J = 125^\circ\text{C}$ (typ.).
- (5) The Human body model is a 100 pF capacitor discharged through a 1.5 k Ω resistor into each pin. (MIL-STD-883 3015.7) The machine model is a 200 pF capacitor discharged directly into each pin.
- (6) TI recommends that all integrated circuits be handled with appropriate precautions. Failure to observe proper ESD handling procedures can result in damage.

OPERATING RATINGS⁽¹⁾⁽²⁾

Input Voltage Range	2.7V to 5.5V
Recommended Load Current	0 mA to 650 mA
Junction Temperature (T_J) Range	-30°C to +125°C
Ambient Temperature (T_A) Range ⁽³⁾	-30°C to +85°C

- (1) Absolute Maximum Ratings indicate limits beyond which damage to the component may occur. Operating Ratings are conditions under which operation of the device is ensured. Operating Ratings do not imply specified performance limits. For specified performance limits and associated test conditions, see the Electrical Characteristics tables.
- (2) All voltages are with respect to the potential at the GND pins. The LM3218 is designed for mobile phone applications where turn-on after power-up is controlled by the system controller and where requirements for a small package size overrule increased die size for internal Under Voltage Lock-Out (UVLO) circuitry. Thus, it should be kept in shutdown by holding the EN pin low until the input voltage exceeds 2.7V.
- (3) In applications where high power dissipation and/or poor package thermal resistance is present, the maximum ambient temperature may have to be de-rated. Maximum ambient temperature (T_{A-MAX}) is dependent on the maximum operating junction temperature ($T_{J-MAX-OP} = 125^\circ\text{C}$), the maximum power dissipation of the device in the application (P_{D-MAX}), and the junction-to ambient thermal resistance of the part/package in the application (θ_{JA}), as given by the following equation: $T_{A-MAX} = T_{J-MAX-OP} - (\theta_{JA} \times P_{D-MAX})$.

THERMAL PROPERTIES

Junction-to-Ambient Thermal Resistance (θ_{JA}), NQA Package ⁽¹⁾	120°C/W
--	---------

- (1) Junction-to-ambient thermal resistance (θ_{JA}) is taken from thermal measurements, performed under the conditions and guidelines set forth in the JEDEC standard JESD51-7. A 4-layer, 4" x 4", 2/1/1/2 oz. Cu board as per JEDEC standards is used for the measurements.

ELECTRICAL CHARACTERISTICS⁽¹⁾⁽²⁾⁽³⁾

Limits in standard typeface are for $T_A = T_J = 25^\circ\text{C}$. Limits in **boldface** type apply over the full operating ambient temperature range ($-30^\circ\text{C} \leq T_A = T_J \leq +85^\circ\text{C}$). Unless otherwise noted, all specifications apply to the LM3218 with: $PV_{IN} = V_{DD} = EN = 3.6\text{V}$.

Symbol	Parameter	Conditions	Min	Typ	Max	Units
$V_{FB, MIN}$	Feedback voltage at minimum setting	$V_{CON} = 0.32\text{V}$ $V_{IN} = 3.6\text{V}^{(3)}$	0.75	0.80	0.85	V
$V_{FB, MAX}$	Feedback voltage at maximum setting	$V_{CON} = 1.44\text{V}$, $V_{IN} = 4.2\text{V}^{(3)}$	3.526	3.600	3.696	V
I_{SHDN}	Shutdown supply current	$EN = V_{OUT} = V_{CON} = 0\text{V}^{(4)}$		0.01	2	μA
I_Q	DC bias current into V_{DD}	$V_{CON} = 0\text{V}$, $FB = 0\text{V}$, No Switching ⁽⁵⁾		0.6	0.7	mA
$R_{DROPOUT}$	$P_{inV_{out}} - P_{inV_{in}}$ resistance	$I_{OUT} = 200\text{mA}$, $V_{CON} = 0.5\text{V}$		300	400	m Ω
$I_{LIM}(L_PFET)$	Large PFET (L) Switch peak current limit	$V_{CON} = 0.5\text{V}^{(6)}$		1100		mA
$I_{LIM}(S_PFET)$	Small PFET (S) Switch peak current limit	$V_{CON} = 0.32\text{V}^{(6)}$		800		mA
F_{OSC}	Internal oscillator frequency			2.0		MHz
$V_{IH,ENABLE}$	Logic high input threshold		1.2			V
$V_{IL,ENABLE}$	Logic low input threshold				0.5	V
$I_{PIN,ENABLE}$	Pin pull down current	$EN = 3.6\text{V}$		5	10	μA
$V_{CON,ON}$	V_{CON} Threshold for turning on switches			0.15		V
I_{CON}	V_{CON} pin leakage current	$V_{CON} = 1.0\text{V}$			± 1	μA
Gain	V_{CON} to V_{OUT} Gain	$0.32\text{V} \leq V_{CON} \leq 1.44\text{V}$		2.5		V/V

- (1) All voltages are with respect to the potential at the GND pins. The LM3218 is designed for mobile phone applications where turn-on after power-up is controlled by the system controller and where requirements for a small package size overrule increased die size for internal Under Voltage Lock-Out (UVLO) circuitry. Thus, it should be kept in shutdown by holding the EN pin low until the input voltage exceeds 2.7V.
- (2) Min and Max limits are specified by design, test, or statistical analysis. Typical numbers are not specified, but do represent the most likely norm. Due to the pulsed nature of the testing $T_A = T_J$ for the electrical characteristics table.
- (3) The parameters in the electrical characteristics table are tested under open loop conditions at $PV_{IN} = V_{DD} = 3.6\text{V}$ unless otherwise specified. For performance over the input voltage range and closed-loop results, refer to the datasheet curves.
- (4) Shutdown current includes leakage current of PFET.
- (5) I_Q specified here is when the part is not switching. For operating quiescent current at no load, refer to datasheet curves.
- (6) Current limit is built-in, fixed, and not adjustable. Electrical Characteristic table reflects open loop data ($FB = 0\text{V}$ and current drawn from SW pin ramped up until cycle by cycle limit is activated). Refer to System Characteristics table for maximum output current.

SYSTEM CHARACTERISTICS

The following spec table entries are specified by design providing the component values in the typical application circuit are used (L = POS Inductor, 2.6 μ H; DCR = 150 m Ω ; C_{IN} = 10 μ F, 6.3V, 0603, TDK C1608X5R0J106K; C_{OUT} = 4.7 μ F, 6.3V, 0603, C1608X5R0J475M). **These parameters are not specified by production testing.** Min and Max values are specified over the ambient temperature range T_A = –30°C to 85°C. Typical values are specified at PV_{IN} = V_{DD} = EN = 3.6V and T_A = 25°C unless otherwise specified.

Symbol	Parameter	Conditions	Min	Typ	Max	Units
T _{RESPONSE} (Rise Time)	Time for V _{OUT} to rise from 0.8V to 3.4V (to reach 3.35V)	V _{IN} = 4.2V R _{LOAD} = 5.5 Ω		25	40	μ s
T _{RESPONSE} (Fall Time)	Time for V _{OUT} to fall from 3.4V to 0.8V	V _{IN} = 4.2V R _{LOAD} = 15 Ω		35	45	μ s
C _{CON}	V _{CON} input capacitance	V _{CON} = 1V, V _{IN} =2.7V to 5.5V Test frequency = 100 KHz		5	10	pF
C _{EN}	EN input capacitance	EN = 2V, V _{IN} = 2.7V to 5.5V Test frequency = 100 KHz		5	10	pF
V _{CON} (S>L)	R _{DSON(P)} management threshold	Threshold for PFET R _{DSON(P)} to change from 960 m Ω to 140 m Ω	0.39	0.42	0.45	V
V _{CON} (L>S)	R _{DSON(P)} management threshold	Threshold for PFET R _{DSON(P)} to change from 140 m Ω to 960 m Ω	0.37	0.40	0.43	V
I _{OUT, MAX}	Maximum Output Current	V _{IN} = 2.7V to 5.5V V _{CON} = 0.45V to 1.44V	650			mA
		V _{IN} = 2.7V to 5.5V V _{CON} = 0.32V to 0.45V	400			mA
Linearity	Linearity in control range 0.32V to 1.44V	V _{IN} = 3.9V ⁽¹⁾ Monotonic in nature	–3		+3	%
			–50		+50	mV
T _{ON}	Turn on time (time for output to reach 97% of final value after Enable low-to-high transition)	EN = Low to High V _{IN} = 4.2V, V _{OUT} = 3.4V, I _{OUT} \leq 1mA		40	60	μ s
η	Efficiency	V _{IN} = 3.6V, V _{OUT} = 0.8V I _{OUT} = 90mA		81		%
		V _{IN} = 3.6V, V _{OUT} = 1.5V I _{OUT} = 150mA		89		%
		V _{IN} = 3.9V, V _{OUT} = 3.4V I _{OUT} = 400 mA		95		%
V _{O_ripple}	Ripple voltage at no pulse skip condition	V _{IN} = 2.7V to 4.5V, V _{OUT} = 0.8V to 3.4V, Differential voltage = V _{IN} - V _{OUT} > 1V, I _{OUT} = 0 mA to 400 mA ⁽²⁾		10		mVp-p
	Ripple voltage at pulse skip condition	V _{IN} = 5.5V to dropout, V _{OUT} = 3.4V, I _{OUT} = 650 mA ⁽²⁾		60		mVp-p
Line_tr	Line transient response	V _{IN} = 3.6V to 4.2V, T _R = T _F = 10 μ s, V _{OUT} = 0.8V, I _{OUT} = 100 mA		50		mVpk
Load_tr	Load transient response	V _{IN} = 3.1/3.6/4.5V, V _{OUT} = 0.8V, I _{OUT} = 50 mA to 150 mA		50		mVpk
Max Duty cycle	Maximum duty cycle		100			%

(1) Linearity limits are \pm 3% or \pm 50 mV whichever is larger.

(2) Ripple voltage should be measured at C_{OUT} electrode on a well-designed PC board and using the suggested inductor and capacitors.

TYPICAL PERFORMANCE CHARACTERISTICS

(Circuit in Figure 32, $PV_{IN} = V_{DD} = EN = 3.6V$ and $T_A = 25^\circ C$ unless otherwise specified.)

Quiescent Current vs Supply Voltage ($V_{CON} = 0V$, $FB = 0V$, No Switching)

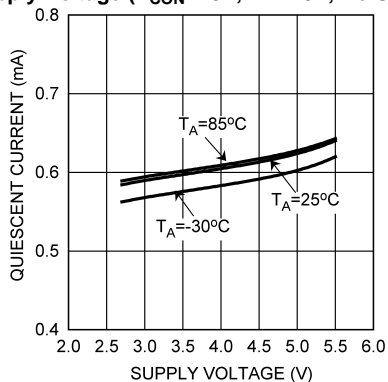

Figure 3.

Shutdown Current vs Temperature ($V_{CON} = 0V$, $EN = 0V$)

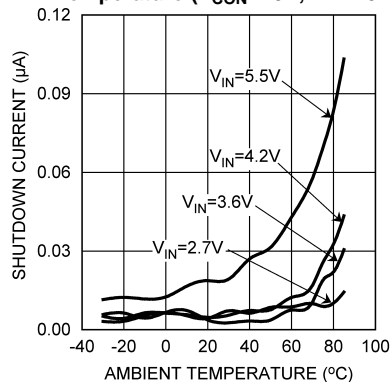

Figure 4.

Switching Frequency vs Temperature ($V_{OUT} = 1.3V$, $I_{OUT} = 200 mA$)

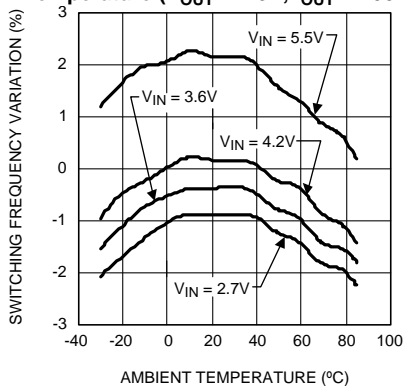

Figure 5.

Output Voltage vs Supply Voltage ($V_{OUT} = 1.3V$)

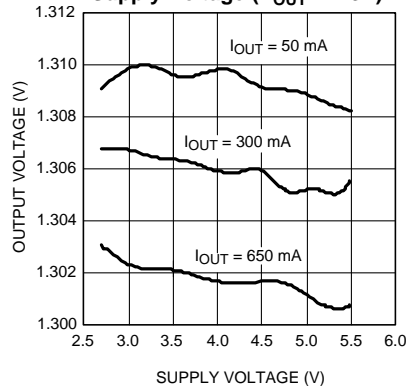

Figure 6.

Output Voltage vs Temperature ($V_{IN} = 3.6V$, $V_{OUT} = 0.8V$)

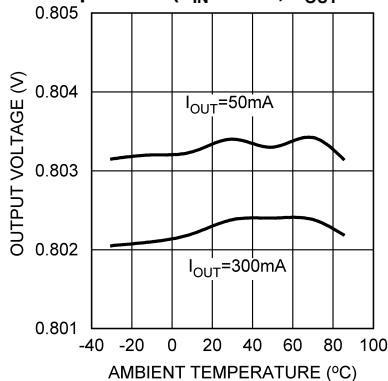

Figure 7.

Output Voltage vs Temperature ($V_{IN} = 4.2V$, $V_{OUT} = 3.4V$)

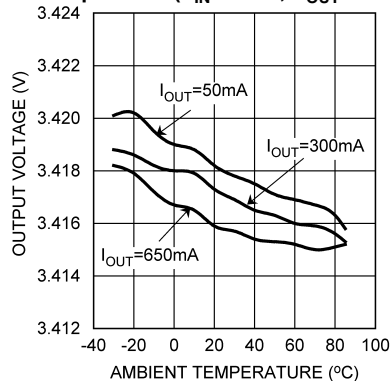

Figure 8.

TYPICAL PERFORMANCE CHARACTERISTICS (continued)

(Circuit in Figure 32, $PV_{IN} = V_{DD} = EN = 3.6V$ and $T_A = 25^\circ C$ unless otherwise specified.)

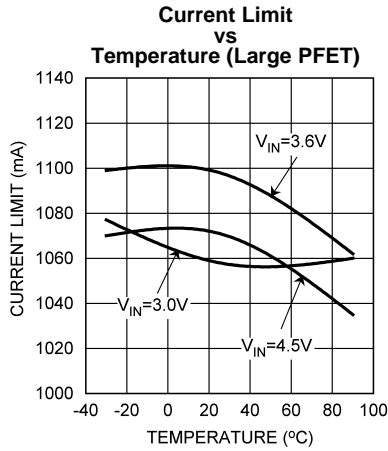

Figure 9.

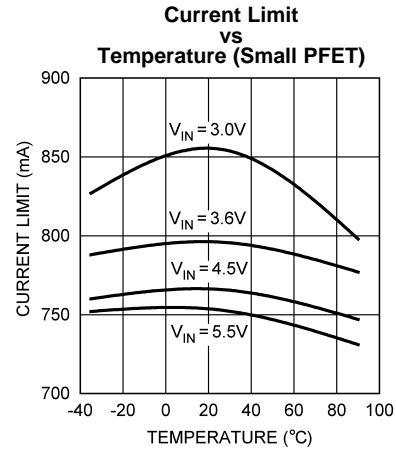

Figure 10.

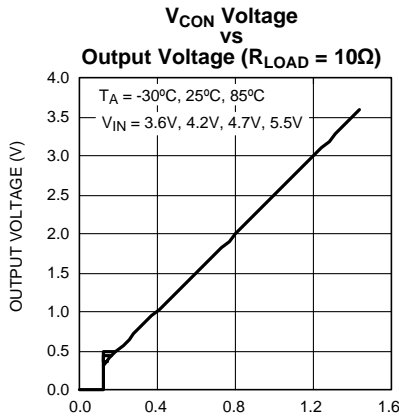

Figure 11.

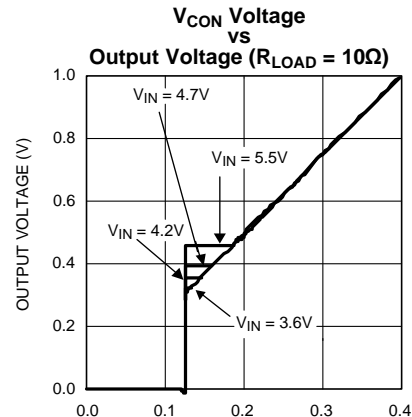

Figure 12.

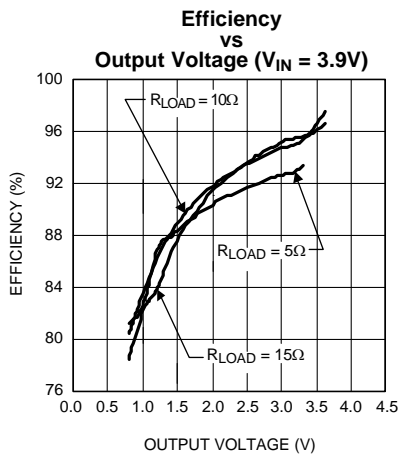

Figure 13.

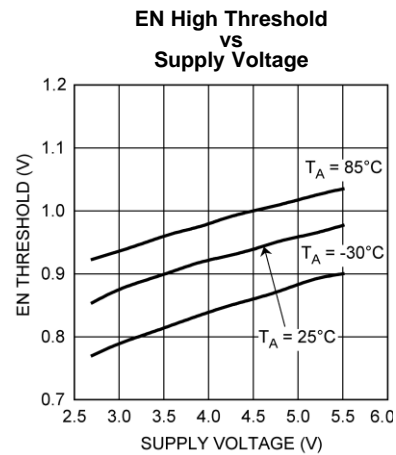

Figure 14.

TYPICAL PERFORMANCE CHARACTERISTICS (continued)

(Circuit in Figure 32, $PV_{IN} = V_{DD} = EN = 3.6V$ and $T_A = 25^\circ C$ unless otherwise specified.)

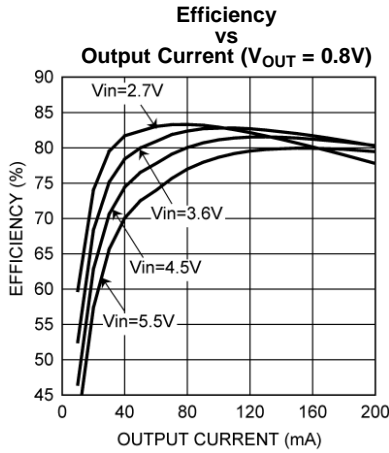

Figure 15.

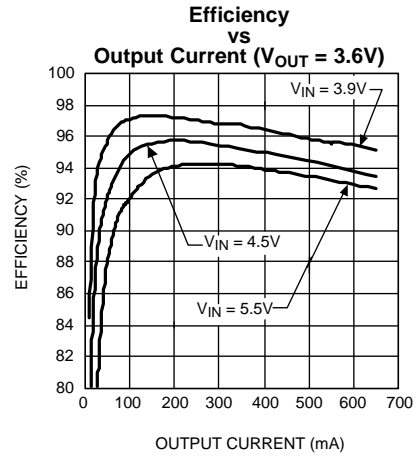

Figure 16.

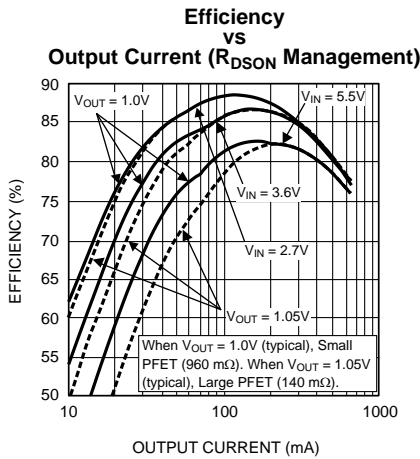

Figure 17.

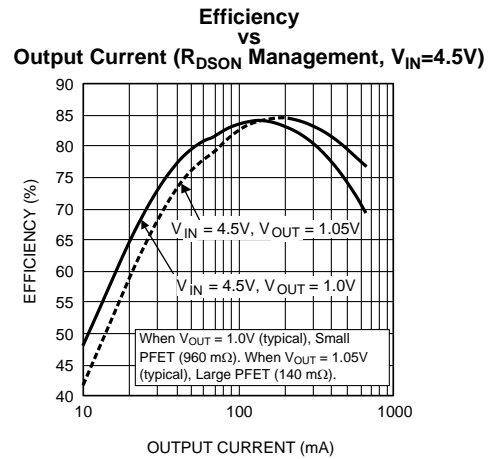

Figure 18.

Dark curves are efficiency profiles of either large PFET or small PFET whichever is higher.

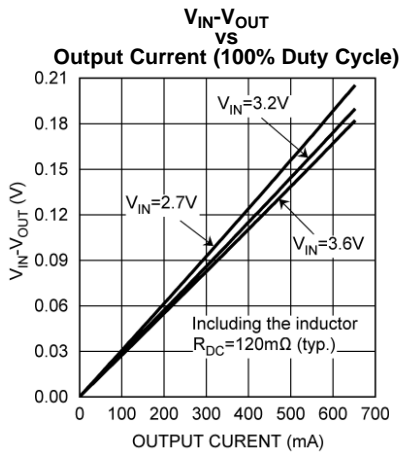

Figure 19.

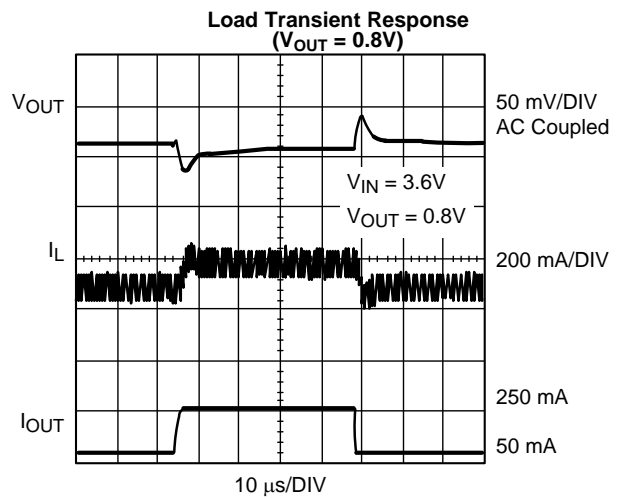

Figure 20.

TYPICAL PERFORMANCE CHARACTERISTICS (continued)

(Circuit in Figure 32, $PV_{IN} = V_{DD} = EN = 3.6V$ and $T_A = 25^\circ C$ unless otherwise specified.)

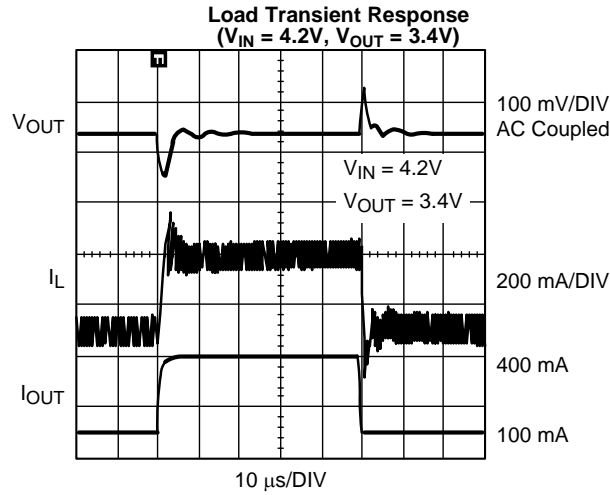

Figure 21.

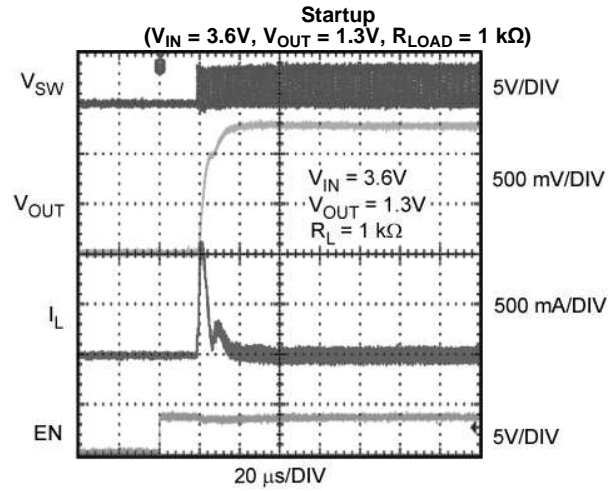

Figure 22.

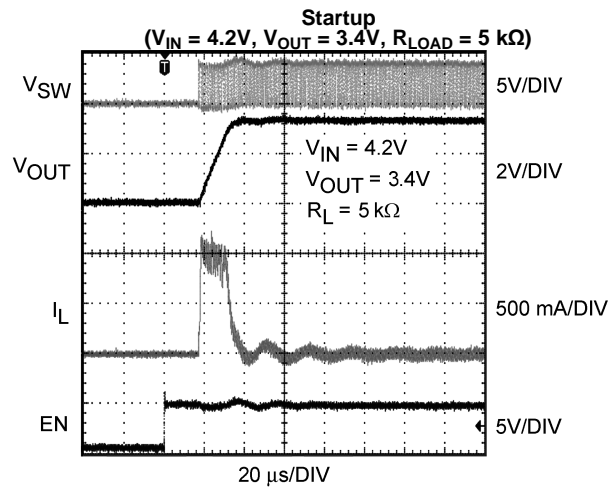

Figure 23.

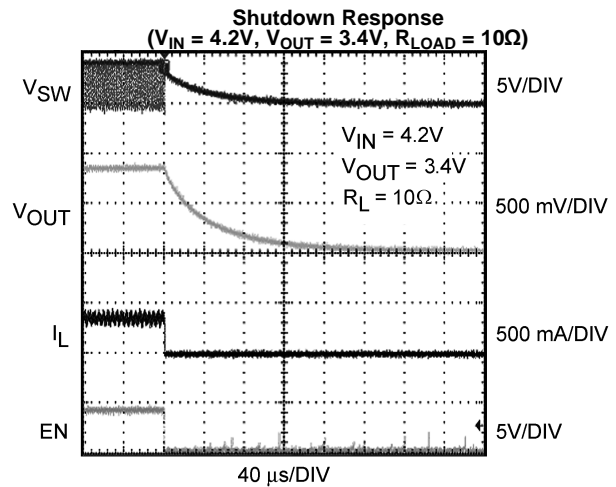

Figure 24.

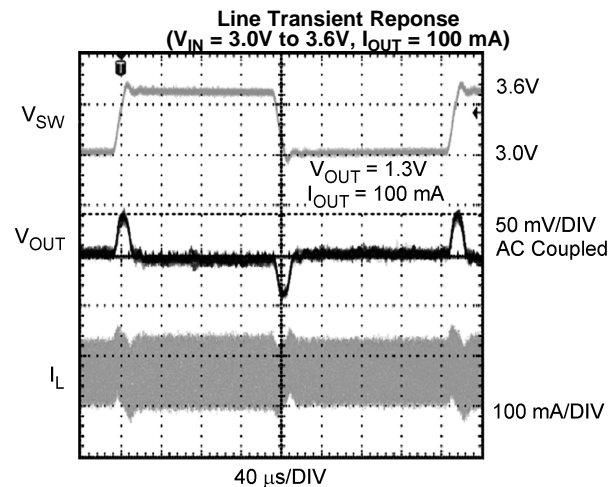

Figure 25.

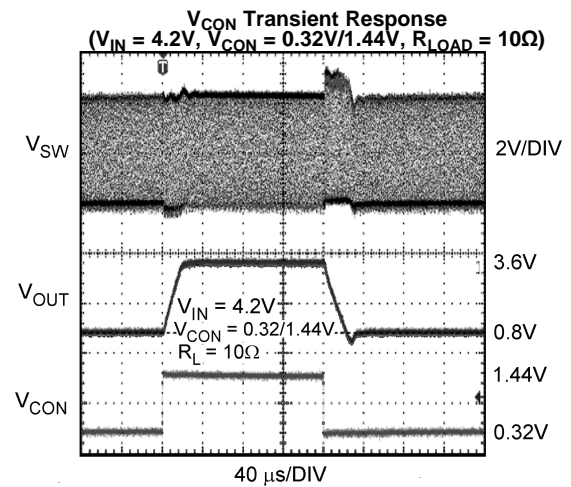

Figure 26.

TYPICAL PERFORMANCE CHARACTERISTICS (continued)

(Circuit in [Figure 32](#), $PV_{IN} = V_{DD} = EN = 3.6V$ and $T_A = 25^\circ C$ unless otherwise specified.)

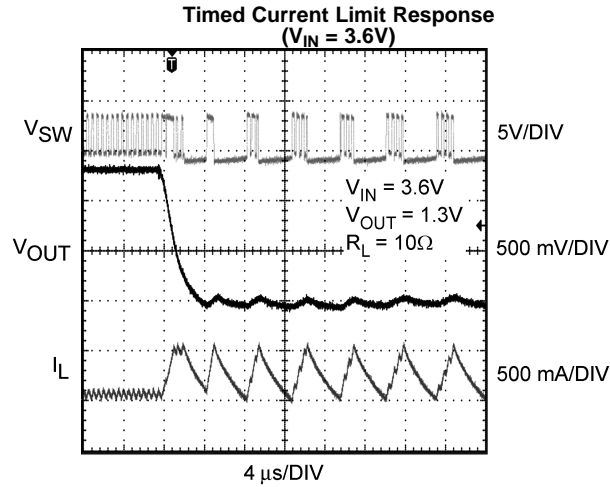

Figure 27.

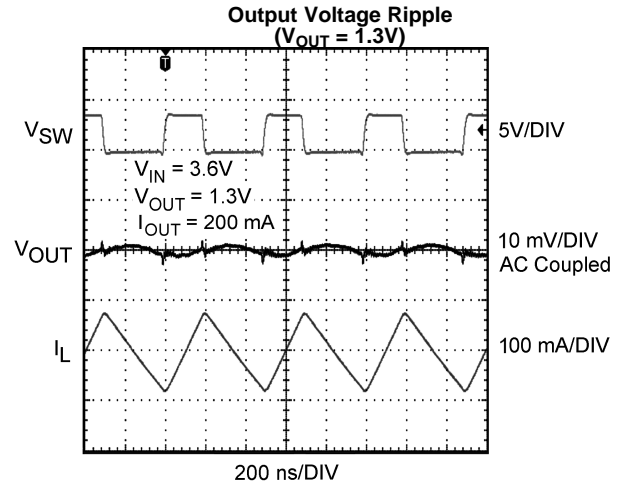

Figure 28.

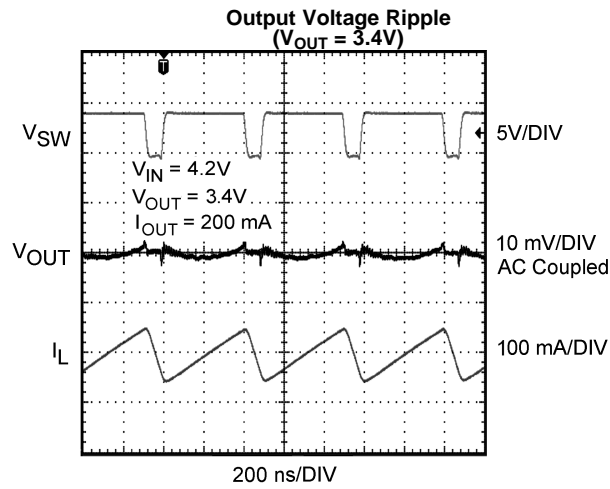

Figure 29.

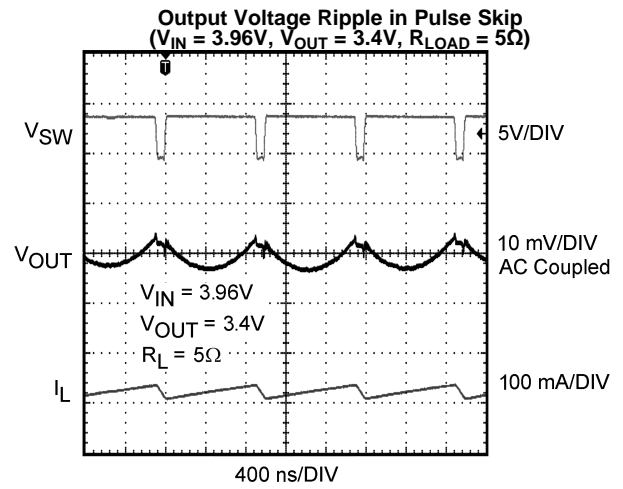

Figure 30.

BLOCK DIAGRAM

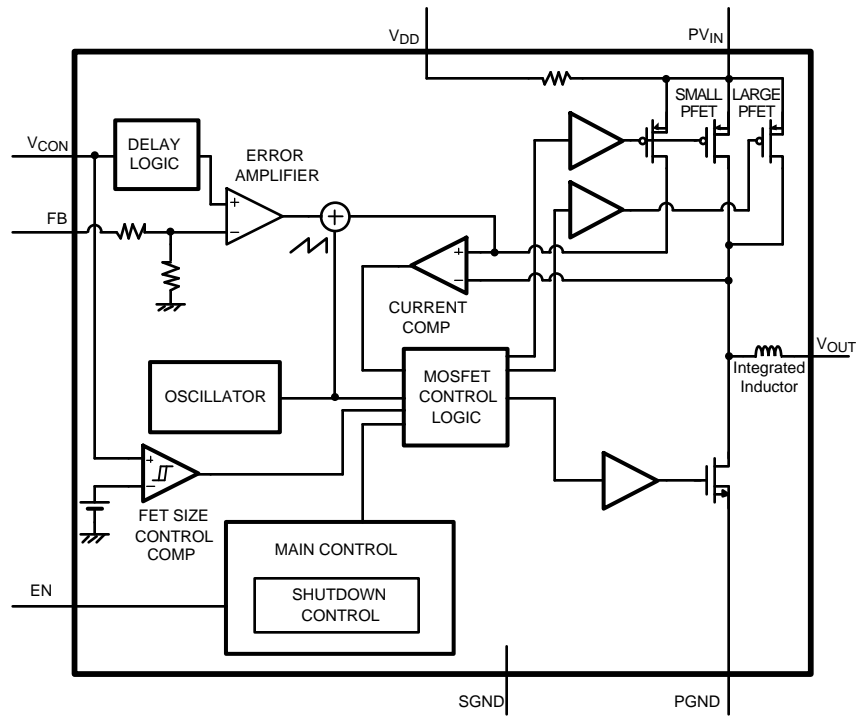

Figure 31. Functional Block Diagram

OPERATION DESCRIPTION

The LM3218 is a simple, step-down DC-DC converter with a 2.6 μH series inductor substrate optimized for powering RF power amplifiers (PAs) in mobile phones, portable communicators, and similar battery powered RF devices. It is designed to allow the RF PA to operate at maximum efficiency over a wide range of power levels from a single Li-Ion battery cell. It is based on current mode buck architecture, with synchronous rectification for high efficiency. It is designed for a maximum load capability of 650 mA when $V_{\text{OUT}} > 1.05\text{V}$ (typ.) and 400 mA when $V_{\text{OUT}} < 1.00\text{V}$ (typ.) in PWM mode.

Maximum load range may vary from this depending on input voltage, output voltage and the inductor chosen.

Efficiency is typically around 95% for a 400 mA load with 3.4V output, 3.9V input. The LM3218 has an $R_{\text{DS(on)}}$ management scheme to increase efficiency when $V_{\text{OUT}} \leq 1\text{V}$. The output voltage is dynamically programmable from 0.8V to 3.6V by adjusting the voltage on the control pin without the need for external feedback resistors. This prolongs battery life by changing the PA supply voltage dynamically depending on its transmitting power.

Additional features include current overload protection and thermal overload shutdown.

The LM3218 is constructed using a chip-scale 8-pin DSBGA package and a POS inductor substrate. This package offers the smallest possible integrated solution footprint for space-critical applications such as cell phones, where board area is an important design consideration. Use of a high switching frequency (2 MHz) reduces the size of external components. As shown in [Figure 1](#), only two external capacitors are required for implementation. Use of this module requires special design considerations for implementation. (See [POS Module Package Assembly and Use](#) in the [Applications Information](#) section). The board mounting requires careful board design and precision assembly equipment. Use of this package is best suited for opaque-case applications, where its edges are not subject to high-intensity ambient red or infrared light. Also, the system controller should set EN low during power-up and other low supply voltage conditions. (See [Shutdown Mode](#) in the [Device Information](#) section.)

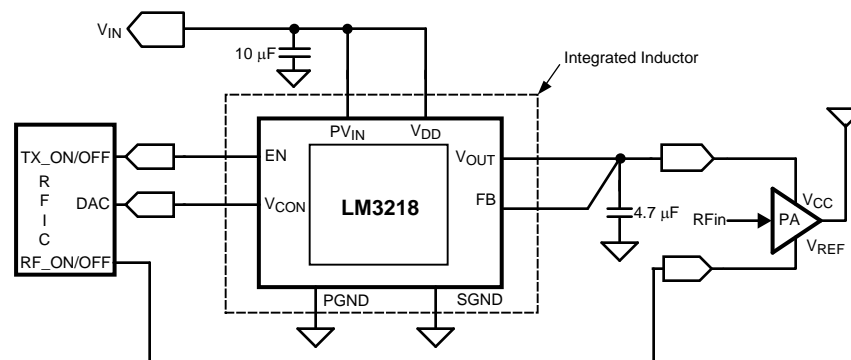

Figure 32. Typical Operating System Circuit

Circuit Operation

Referring to [Figure 1](#) and [Figure 31](#), the LM3218 operates as follows: During the first part of each switching cycle, the control block in the LM3218 turns on the internal PFET (P-channel MOSFET) switch. This allows current to flow from the input through the inductor to the output filter capacitor and load. The inductor limits the current to a ramp with a slope of around $(V_{\text{IN}} - V_{\text{OUT}}) / L$, by storing energy in a magnetic field. During the second part of each cycle, the controller turns the PFET switch off, blocking current flow from the input, and then turns the NFET (N-channel MOSFET) synchronous rectifier on. In response, the inductor's magnetic field collapses, generating a voltage that forces current from ground through the synchronous rectifier to the output filter capacitor and load. As the stored energy is transferred back into the circuit and depleted, the inductor current ramps down with a slope around V_{OUT} / L . The output filter capacitor stores charge when the inductor current is high, and releases it when low, smoothing the voltage across the load.

The output voltage is regulated by modulating the PFET switch on time to control the average current sent to the load. The effect is identical to sending a duty-cycle modulated rectangular wave formed by the power MOSFET switch and synchronous rectifier to a low-pass filter formed by the inductor and output filter capacitor. The output voltage is equal to the average voltage at the terminal of the power MOSFET inverter.

While in operation, the output voltage is regulated by switching at a constant frequency and then modulating the energy per cycle to control power to the load. Energy per cycle is set by modulating the PFET switch on-time pulse width to control the peak inductor current. This is done by comparing the signal from the current-sense amplifier with a slope compensated error signal from the voltage-feedback error amplifier. At the beginning of each cycle, the clock turns on the PFET switch, causing the inductor current to ramp up. When the current sense signal ramps past the error amplifier signal, the PWM comparator turns off the PFET switch and turns on the NFET synchronous rectifier, ending the first part of the cycle. If an increase in load pulls the output down, the error amplifier output increases, which allows the inductor current to ramp higher before the comparator turns off the PFET. This increases the average current sent to the output and adjusts for the increase in the load. Before appearing at the PWM comparator, a slope compensation ramp from the oscillator is subtracted from the error signal for stability of the current feedback loop. The minimum on time of PFET is 55 ns (typ.)

Shutdown Mode

Setting the EN digital pin low (<0.5V) places the LM3218 in shutdown mode (0.01 μ A typ.). During shutdown, the PFET switch, NFET synchronous rectifier, reference voltage source, control and bias circuitry of the LM3218 are turned off. Setting EN high (>1.2V) enables normal operation.

EN should be set low to turn off the LM3218 during power-up and under-voltage conditions when the power supply is less than the 2.7V minimum operating voltage. The LM3218 is designed for compact portable applications, such as mobile phones. In such applications, the system controller determines power supply sequencing and requirements for small package size outweigh the additional size required for inclusion of UVLO (Under Voltage Lock-Out) circuitry.

Internal Synchronous Rectification

While in PWM mode, the LM3218 uses an internal NFET as a synchronous rectifier to reduce rectifier forward voltage drop and associated power loss. Synchronous rectification provides a significant improvement in efficiency whenever the output voltage is relatively low compared to the voltage drop across an ordinary rectifier diode.

The internal NFET synchronous rectifier is turned on during the inductor current down slope in the second part of each cycle. The synchronous rectifier is turned off prior to the next cycle. The NFET is designed to conduct through its intrinsic body diode during transient intervals before it turns on, eliminating the need for an external diode.

$R_{\text{DSON(P)}}$ Management

The LM3218 has a unique $R_{\text{DSON(P)}}$ management function to improve efficiency in the low output current region up to 100 mA. When the V_{CON} voltage is less than 0.40V (typ.), the device uses only a small part of the PFET to minimize drive loss of the PFET. When V_{CON} is greater than 0.42V (typ.), the entire PFET is used to minimize $R_{\text{DSON(P)}}$ loss. This threshold has about 20 mV (typ.) of hysteresis.

$V_{\text{CON,ON}}$

The output is disabled when V_{CON} is below 125 mV (typ.). It is enabled when V_{CON} is above 150 mV (typ.). The threshold has about 25 mV (typ.) of hysteresis.

Current Limiting

A current limit feature allows the LM3218 to protect itself and external components during overload conditions. In PWM mode, an 1100 mA (typ.) cycle-by-cycle current limit is normally used when V_{CON} is above 0.42V (typ.), and an 800 mA (typ.) is used when V_{CON} is below 0.40V (typ.). If an excessive load pulls the output voltage down to approximately 0.375V, then the device switches to a timed current limit mode when V_{CON} is above 0.42V (typ.). In timed current limit mode the internal PFET switch is turned off after the current comparator trips and the beginning of the next cycle is inhibited for 3.5 μ s to force the instantaneous inductor current to ramp down to a safe value. The synchronous rectifier is off in timed current limit mode. Timed current limit prevents the loss of current control seen in some products when the output voltage is pulled low in serious overload conditions.

Dynamically Adjustable Output Voltage

The LM3218 features dynamically adjustable output voltage to eliminate the need for external feedback resistors. The output can be set from 0.8V to 3.6V by changing the voltage on the analog V_{CON} pin. This feature is useful in PA applications where peak power is needed only when the handset is far away from the base station or when data is being transmitted. In other instances, the transmitting power can be reduced. Hence the supply voltage to the PA can be reduced, promoting longer battery life. See *Setting the Output Voltage* in the [Application Information](#) section for further details. The LM3218 moves into Pulse Skipping mode when duty cycle is over 92% and the output voltage ripple increases slightly.

Thermal Overload Protection

The LM3218 has a thermal overload protection function that operates to protect itself from short-term misuse and overload conditions. When the junction temperature exceeds around 150°C, the device inhibits operation. Both the PFET and the NFET are turned off in PWM mode. When the temperature drops below 125°C, normal operation resumes. Prolonged operation in thermal overload conditions may damage the device and is considered bad practice.

APPLICATION INFORMATION

SETTING THE OUTPUT VOLTAGE

The LM3218 features a pin-controlled variable output voltage to eliminate the need for external feedback resistors. It can be programmed for an output voltage from 0.8V to 3.6V by setting the voltage on the V_{CON} pin, as in the following formula:

$$V_{OUT} = 2.5 \times V_{CON} \quad (1)$$

When V_{CON} is between 0.32V and 1.44V, the output voltage will follow proportionally by 2.5 times of V_{CON} .

If V_{CON} is over 1.44V ($V_{OUT} = 3.6V$), sub-harmonic oscillation may occur because of insufficient slope compensation. If V_{CON} voltage is less than 0.32V ($V_{OUT} = 0.8V$), the output voltage may not be regulated due to the required on-time being less than the minimum on-time (55 ns). The output voltage can go lower than 0.8V providing a limited V_{IN} range is used. Refer to datasheet curve (*V_{CON} Voltage vs Output Voltage*) for details. This curve is for a typical part and there could be part-to-part variation for output voltages less than 0.8V over the limited V_{IN} range. When the control pin voltage is more than 0.15V (typ.), the switches are turned on. When it is less than 0.125V (typ.), the switches are turned off. This on/off function has 25 mV (typ.) hysteresis. The quiescent current when ($V_{CON} = 0V$ and $V_{EN} = Hi$) is around 600 μA .

ESTIMATION OF MAXIMUM OUTPUT CURRENT CAPABILITY

Referring to [Figure 32](#), the Inductor peak-to-peak ripple current can be estimated by:

$$I_{IND_PP} = (V_{IN} - V_{OUT}) \times V_{OUT} / (L1 \times F_{SW} \times V_{IN}) \quad (2)$$

Where, F_{sw} is switching frequency.

Therefore, maximum output current can be calculated by:

$$I_{OUT_MAX} = I_{LIM} - 0.5 \times I_{IND_PP} \quad (3)$$

For the worst case calculation, the following parameters should be used:

F_{SW} (Lowest switching frequency): 1.8 MHz

I_{LIM} (Lowest current limit value): 985 mA

$L1$ (Lowest inductor value): refer to inductor datasheet. Note that inductance will drop with DC bias current and temperature. The worst case is typically at 85°C.

For example, $V_{IN} = 4.2V$, $V_{OUT} = 3.2V$, $L1 = 2.0 \mu H$ (Inductance value at 985 mA DC-bias current and 85°C), $F_{SW} = 1.8 \text{ MHz}$, $I_{LIM} = 985 \text{ mA}$.

$$I_{IND_PP} = 212 \text{ mA} \quad (4)$$

$$I_{OUT_MAX} = 985 - 106 = 876 \text{ mA} \quad (5)$$

The effects of switch, inductor resistance and dead time are ignored. In real application, the ripple current would be 10% to 15% higher than ideal case. This should be taken into account when calculating maximum output current. Special attention needs to be paid that a delta between maximum output current capability and the current limit is necessary to satisfy transient response requirements. In practice, transient response requirements may not be met for output current greater than 650 mA.

INDUCTOR SELECTION

The inductor is an integrated POS 2.6 μH substrate within the LM3218 module and has a saturation current rating over 1200 mA. The integrated inductor's low 1.2 mm maximum height provides ease of use into small design constraints. Integrating the inductor can eliminate layout issues associated with DC/DC converters and reduce potential EMI problems.

CAPACITOR SELECTION

The LM3218 is designed for use with ceramic capacitors for its input and output filters. Use a 10 μF ceramic capacitor for input and a 4.7 μF ceramic capacitor for output. They should maintain at least 50% capacitance at DC bias and temperature conditions. Ceramic capacitor types such as X5R, X7R and B are recommended for both filters. Table 1 lists some suggested part numbers and suppliers. DC bias characteristics of the capacitors must be considered when selecting the voltage rating and case size of the capacitor. If it is necessary to choose a 0603-size capacitor for C_{IN} and C_{OUT} , the operation of the LM3218 should be carefully evaluated on the system board. Use of multiple 2.2 μF or 1 μF capacitors in parallel may also be considered.

Table 1. Suggested Capacitors And Their Suppliers

Model	Vendor
C1608X5R0J106K, 10 μF , 6.3V	TDK
C1608X5R0J475M, 4.7 μF , 6.3V	TDK
0805ZD475KA 4.7 μF , 10V	AVX

The input filter capacitor supplies AC current drawn by the PFET switch of the LM3218 in the first part of each cycle and reduces the voltage ripple imposed on the input power source. The output filter capacitor absorbs the AC inductor current, helps maintain a steady output voltage during transient load changes and reduces output voltage ripple. These capacitors must be selected with sufficient capacitance and sufficiently low ESR (Equivalent Series Resistance) to perform these functions. The ESR of the filter capacitors is generally a major factor in voltage ripple.

EN PIN CONTROL

Drive the EN pin using the system controller to turn the LM3218 ON and OFF. Use a comparator, Schmidt trigger or logic gate to drive the EN pin. Set EN high (>1.2V) for normal operation and low (<0.5V) for a 0.01 μA (typ.) shutdown mode and requirements for small package size outweigh the additional size required for inclusion of UVLO (Under Voltage Lock-Out) circuitry.

POS PACKAGE ASSEMBLY AND USE

The POS Integrated Inductor with LM3218 DSBGA package is optimized for the smallest possible size in applications with red or infrared opaque cases. Because the DSBGA package lacks the plastic encapsulation characteristic of larger devices, it is vulnerable to light. Backside metalization and/or epoxy coating, along with front-side shading by the printed circuit board, reduce this sensitivity. However, the package has exposed die edges. In particular, DSBGA devices are sensitive to light, in the red and infrared range, shining on the package's exposed die edges. The maximum shelf life after opening the dry pack is 168 hours, no bake allowed as it will further degrade the solder ability.

BOARD LAYOUT CONSIDERATIONS

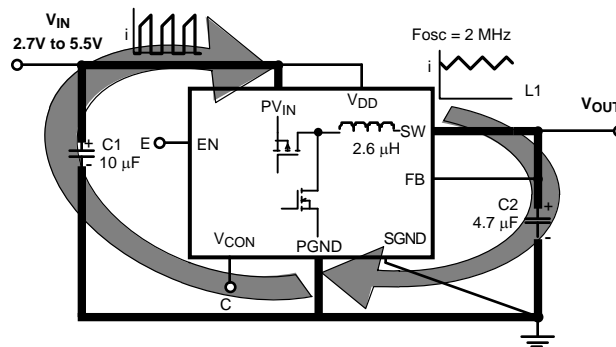

Figure 33. Current Loop

The LM3218 converts higher input voltage to lower output voltage with high efficiency. This is achieved with an inductor-based switching topology. During the first half of the switching cycle, the internal PMOS switch turns on, the input voltage is applied to the inductor, and the current flows from PV_{IN} line into the output capacitor and the load through the inductor. During the second half cycle, the PMOS turns off and the internal NMOS turns on. The inductor current continues to flow via the inductor from the device PGND line into the output capacitor and the load.

Referring to [Figure 33](#), a pulse current flows in the left-hand side loop, and a ripple current flows in the right-hand side loop. Board layout and circuit pattern design of these two loops are the key factors for reducing noise radiation and stable operation. In other lines, such as from battery to C1 and C2 to the load, the current is mostly DC current. Therefore, it is not necessary to take so much care. Only pattern width (current capability) and DCR drop considerations are needed.

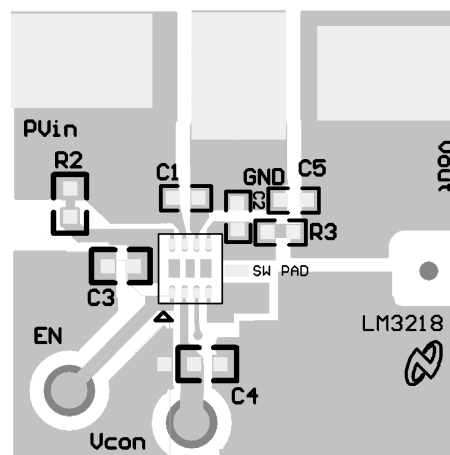

Figure 34. Evaluation Board Layout

REVISION HISTORY

Changes from Revision A (March 2013) to Revision B	Page
• Changed layout of National Data Sheet to TI format	16

PACKAGING INFORMATION

Orderable Device	Status (1)	Package Type	Package Drawing	Pins	Package Qty	Eco Plan (2)	Lead/Ball Finish (6)	MSL Peak Temp (3)	Op Temp (°C)	Device Marking (4/5)	Samples
LM3218SEE/NOPB	OBSOLETE	POS	NQA	8		TBD	Call TI	Call TI			
LM3218SEX/NOPB	OBSOLETE	POS	NQA	8		TBD	Call TI	Call TI			

(1) The marketing status values are defined as follows:

ACTIVE: Product device recommended for new designs.

LIFEBUY: TI has announced that the device will be discontinued, and a lifetime-buy period is in effect.

NRND: Not recommended for new designs. Device is in production to support existing customers, but TI does not recommend using this part in a new design.

PREVIEW: Device has been announced but is not in production. Samples may or may not be available.

OBSOLETE: TI has discontinued the production of the device.

(2) Eco Plan - The planned eco-friendly classification: Pb-Free (RoHS), Pb-Free (RoHS Exempt), or Green (RoHS & no Sb/Br) - please check <http://www.ti.com/productcontent> for the latest availability information and additional product content details.

TBD: The Pb-Free/Green conversion plan has not been defined.

Pb-Free (RoHS): TI's terms "Lead-Free" or "Pb-Free" mean semiconductor products that are compatible with the current RoHS requirements for all 6 substances, including the requirement that lead not exceed 0.1% by weight in homogeneous materials. Where designed to be soldered at high temperatures, TI Pb-Free products are suitable for use in specified lead-free processes.

Pb-Free (RoHS Exempt): This component has a RoHS exemption for either 1) lead-based flip-chip solder bumps used between the die and package, or 2) lead-based die adhesive used between the die and leadframe. The component is otherwise considered Pb-Free (RoHS compatible) as defined above.

Green (RoHS & no Sb/Br): TI defines "Green" to mean Pb-Free (RoHS compatible), and free of Bromine (Br) and Antimony (Sb) based flame retardants (Br or Sb do not exceed 0.1% by weight in homogeneous material)

(3) MSL, Peak Temp. - The Moisture Sensitivity Level rating according to the JEDEC industry standard classifications, and peak solder temperature.

(4) There may be additional marking, which relates to the logo, the lot trace code information, or the environmental category on the device.

(5) Multiple Device Markings will be inside parentheses. Only one Device Marking contained in parentheses and separated by a "~" will appear on a device. If a line is indented then it is a continuation of the previous line and the two combined represent the entire Device Marking for that device.

(6) Lead/Ball Finish - Orderable Devices may have multiple material finish options. Finish options are separated by a vertical ruled line. Lead/Ball Finish values may wrap to two lines if the finish value exceeds the maximum column width.

Important Information and Disclaimer: The information provided on this page represents TI's knowledge and belief as of the date that it is provided. TI bases its knowledge and belief on information provided by third parties, and makes no representation or warranty as to the accuracy of such information. Efforts are underway to better integrate information from third parties. TI has taken and continues to take reasonable steps to provide representative and accurate information but may not have conducted destructive testing or chemical analysis on incoming materials and chemicals. TI and TI suppliers consider certain information to be proprietary, and thus CAS numbers and other limited information may not be available for release.

In no event shall TI's liability arising out of such information exceed the total purchase price of the TI part(s) at issue in this document sold by TI to Customer on an annual basis.

NQA0008A

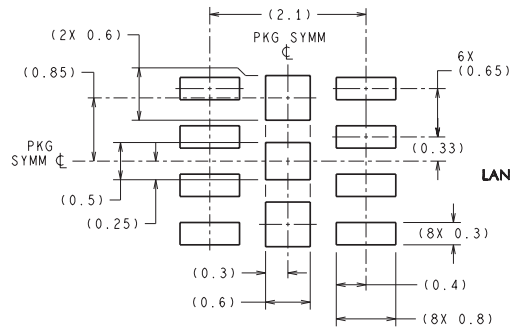

DIMENSIONS ARE IN MILLIMETERS
DIMENSIONS IN () FOR REFERENCE ONLY

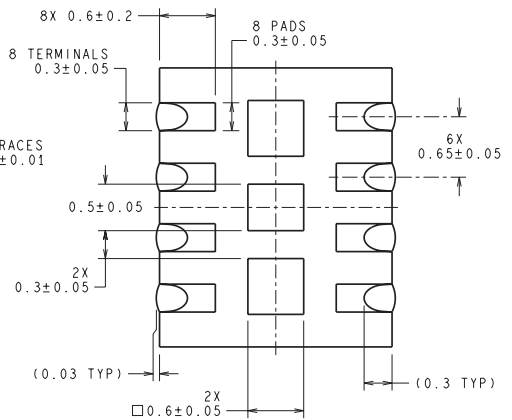
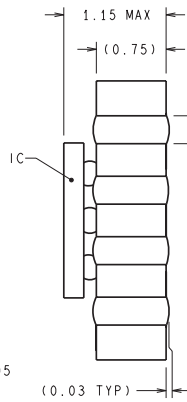
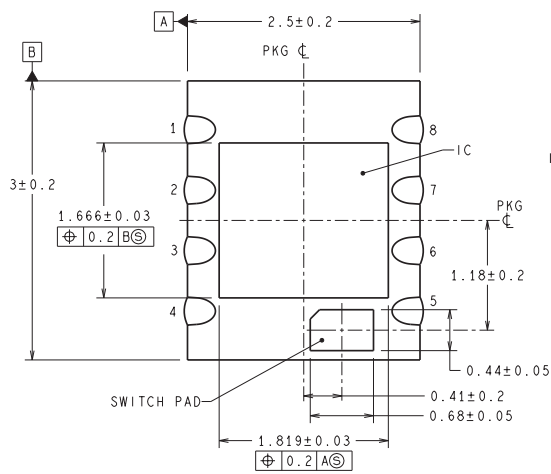

SE08A (Rev D)

IMPORTANT NOTICE

Texas Instruments Incorporated and its subsidiaries (TI) reserve the right to make corrections, enhancements, improvements and other changes to its semiconductor products and services per JESD46, latest issue, and to discontinue any product or service per JESD48, latest issue. Buyers should obtain the latest relevant information before placing orders and should verify that such information is current and complete. All semiconductor products (also referred to herein as "components") are sold subject to TI's terms and conditions of sale supplied at the time of order acknowledgment.

TI warrants performance of its components to the specifications applicable at the time of sale, in accordance with the warranty in TI's terms and conditions of sale of semiconductor products. Testing and other quality control techniques are used to the extent TI deems necessary to support this warranty. Except where mandated by applicable law, testing of all parameters of each component is not necessarily performed.

TI assumes no liability for applications assistance or the design of Buyers' products. Buyers are responsible for their products and applications using TI components. To minimize the risks associated with Buyers' products and applications, Buyers should provide adequate design and operating safeguards.

TI does not warrant or represent that any license, either express or implied, is granted under any patent right, copyright, mask work right, or other intellectual property right relating to any combination, machine, or process in which TI components or services are used. Information published by TI regarding third-party products or services does not constitute a license to use such products or services or a warranty or endorsement thereof. Use of such information may require a license from a third party under the patents or other intellectual property of the third party, or a license from TI under the patents or other intellectual property of TI.

Reproduction of significant portions of TI information in TI data books or data sheets is permissible only if reproduction is without alteration and is accompanied by all associated warranties, conditions, limitations, and notices. TI is not responsible or liable for such altered documentation. Information of third parties may be subject to additional restrictions.

Resale of TI components or services with statements different from or beyond the parameters stated by TI for that component or service voids all express and any implied warranties for the associated TI component or service and is an unfair and deceptive business practice. TI is not responsible or liable for any such statements.

Buyer acknowledges and agrees that it is solely responsible for compliance with all legal, regulatory and safety-related requirements concerning its products, and any use of TI components in its applications, notwithstanding any applications-related information or support that may be provided by TI. Buyer represents and agrees that it has all the necessary expertise to create and implement safeguards which anticipate dangerous consequences of failures, monitor failures and their consequences, lessen the likelihood of failures that might cause harm and take appropriate remedial actions. Buyer will fully indemnify TI and its representatives against any damages arising out of the use of any TI components in safety-critical applications.

In some cases, TI components may be promoted specifically to facilitate safety-related applications. With such components, TI's goal is to help enable customers to design and create their own end-product solutions that meet applicable functional safety standards and requirements. Nonetheless, such components are subject to these terms.

No TI components are authorized for use in FDA Class III (or similar life-critical medical equipment) unless authorized officers of the parties have executed a special agreement specifically governing such use.

Only those TI components which TI has specifically designated as military grade or "enhanced plastic" are designed and intended for use in military/aerospace applications or environments. Buyer acknowledges and agrees that any military or aerospace use of TI components which have **not** been so designated is solely at the Buyer's risk, and that Buyer is solely responsible for compliance with all legal and regulatory requirements in connection with such use.

TI has specifically designated certain components as meeting ISO/TS16949 requirements, mainly for automotive use. In any case of use of non-designated products, TI will not be responsible for any failure to meet ISO/TS16949.

Products

Audio	www.ti.com/audio
Amplifiers	amplifier.ti.com
Data Converters	dataconverter.ti.com
DLP® Products	www.dlp.com
DSP	dsp.ti.com
Clocks and Timers	www.ti.com/clocks
Interface	interface.ti.com
Logic	logic.ti.com
Power Mgmt	power.ti.com
Microcontrollers	microcontroller.ti.com
RFID	www.ti-rfid.com
OMAP Applications Processors	www.ti.com/omap
Wireless Connectivity	www.ti.com/wirelessconnectivity

Applications

Automotive and Transportation	www.ti.com/automotive
Communications and Telecom	www.ti.com/communications
Computers and Peripherals	www.ti.com/computers
Consumer Electronics	www.ti.com/consumer-apps
Energy and Lighting	www.ti.com/energy
Industrial	www.ti.com/industrial
Medical	www.ti.com/medical
Security	www.ti.com/security
Space, Avionics and Defense	www.ti.com/space-avionics-defense
Video and Imaging	www.ti.com/video

TI E2E Community

e2e.ti.com

Looking for pricing, stock, or lifecycle information?

Click below to explore more details on WIN SOURCE:

 [View LM3218SEX/NOPB on WIN SOURCE](#)

 [Texas Instruments](#) Information

Optimize Your Supply Chain with WIN SOURCE Solutions

-  Global Sourcing Solution
-  Obsolete Management
-  Cost Control Management
-  Shortage Management
-  Alternative Solution
-  Excess Inventory Management