



**THE DATASHEET OF  
CAXC4T245QBQBRQ1**



# SN74AXC4T245-Q1 Automotive 4-Bit Dual-Supply Bus Transceiver With Configurable Voltage Translation and Tri-State Outputs

## 1 Features

- AEC-Q100 qualified for automotive applications
- Available in wetttable flank QFN (WBQB) package
- Fully-configurable dual-rail design allows each port to operate with a power supply range from 0.65V to 3.6V
- Operating temperature from  $-40^{\circ}\text{C}$  to  $+125^{\circ}\text{C}$
- Multiple direction control pins to allow simultaneous up and down translation
- Glitch-free power supply sequencing
- Up to 380 Mbps support when translating from 1.8V to 3.3V
- $V_{CC}$  isolation feature:
  - If either  $V_{CC}$  input is below 100mV, all I/O outputs are disabled and become high impedance
- $I_{off}$  supports partial-power-down mode operation
- Compatible with AVC-family level shifters
- Latch-up performance exceeds 100mA per JESD 78, class II
- ESD protection exceeds JEDEC JS-001
  - 8000V human-body model
  - 1000V charged-device model

## 2 Applications

- [Infotainment head unit](#)
- [ADAS fusion](#)
- [ADAS front camera](#)
- [Hybrid electric vehicles and electric vehicles battery management system](#)
- [Telematics control unit](#)

## 3 Description

The SN74AXC4T245-Q1 AEC-Q100 qualified device is a four-bit non-inverting bus transceiver that uses two individually configurable power-supply rails. The device is operational with both  $V_{CCA}$  and  $V_{CCB}$  supplies as low as 0.65V. The A port is designed to track  $V_{CCA}$ , which accepts any supply voltage from 0.65V to 3.6V. The B port is designed to track  $V_{CCB}$ , which also accepts any supply voltage from 0.65V to 3.6V. Additionally the SN74AXC4T245-Q1 is compatible with a single-supply system.

The SN74AXC4T245-Q1 device is designed for asynchronous communication between data buses. The device transmits data from the A bus to the B bus or from the B bus to the A bus, depending on the logic level of the direction-control inputs (1DIR and 2DIR). The output-enable inputs (1  $\overline{OE}$  and 2  $\overline{OE}$ ) are used to disable the outputs so the buses are effectively isolated. The SN74AXC4T245-Q1 device is designed so the control pins (xDIR and x  $\overline{OE}$ ) are referenced to  $V_{CCA}$ .

To put the level shifter I/Os in the high-impedance state during power up or power down, tie the x  $\overline{OE}$  pins to  $V_{CCA}$  through a pull-up resistor.

This device is fully specified for partial-power-down applications using the  $I_{off}$  current. The  $I_{off}$  protection circuitry is designed so that no excessive current is drawn from or to an input, output, or combined I/O that is biased to a specific voltage while the device is powered down.

The  $V_{CC}$  isolation feature is designed so that if either  $V_{CCA}$  or  $V_{CCB}$  is less than 100mV, both I/O ports enter a high-impedance state by disabling their outputs.

Glitch-Free power supply sequencing allows either supply rail to be powered on or off in any order while providing robust power sequencing performance.

### Package Information

PART NUMBER	PACKAGE <sup>(1)</sup>	PACKAGE SIZE <sup>(2)</sup>
SN74AXC4T245-Q1	PW (TSSOP, 16)	5mm × 6.4mm
	BQB (WQFN, 16)	3.5mm × 2.5mm
	RSV (UQFN, 16)	2.6mm × 1.8mm

(1) For more information, see [Section 11](#)

(2) The package size (length × width) is a nominal value and includes pins, where applicable.

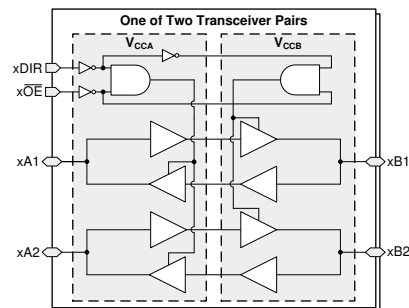

Functional Block Diagram



## Table of Contents

<b>1 Features</b> .....	1	6.1 Load Circuit and Voltage Waveforms.....	18
<b>2 Applications</b> .....	1	<b>7 Detailed Description</b> .....	20
<b>3 Description</b> .....	1	7.1 Overview.....	20
<b>4 Pin Configuration and Functions</b> .....	3	7.2 Functional Block Diagram.....	20
<b>5 Specifications</b> .....	4	7.3 Feature Description.....	20
5.1 Absolute Maximum Ratings.....	4	7.4 Device Functional Modes.....	22
5.2 ESD Ratings.....	4	<b>8 Application and Implementation</b> .....	23
5.3 Recommended Operating Conditions.....	5	8.1 Application Information.....	23
5.4 Thermal Information.....	5	8.2 Typical Application.....	23
5.5 Electrical Characteristics.....	6	8.3 Power Supply Recommendations.....	24
5.6 Switching Characteristics, $V_{CCA} = 0.7V \pm 0.05V$ .....	7	8.4 Layout.....	25
5.7 Switching Characteristics, $V_{CCA} = 0.8V \pm 0.04V$ .....	8	<b>9 Device and Documentation Support</b> .....	26
5.8 Switching Characteristics, $V_{CCA} = 0.9V \pm 0.045V$ .....	9	9.1 Documentation Support.....	26
5.9 Switching Characteristics, $V_{CCA} = 1.2V \pm 0.1V$ .....	10	9.2 Receiving Notification of Documentation Updates....	26
5.10 Switching Characteristics, $V_{CCA} = 1.5V \pm 0.1V$ .....	11	9.3 Support Resources.....	26
5.11 Switching Characteristics, $V_{CCA} = 1.8V \pm 0.15V$ .....	12	9.4 Trademarks.....	26
5.12 Switching Characteristics, $V_{CCA} = 2.5V \pm 0.2V$ .....	13	9.5 Electrostatic Discharge Caution.....	26
5.13 Switching Characteristics, $V_{CCA} = 3.3V \pm 0.3V$ .....	14	9.6 Glossary.....	26
5.14 Operating Characteristics: $T_A = 25^\circ C$ .....	15	<b>10 Revision History</b> .....	26
5.15 Typical Characteristics.....	17	<b>11 Mechanical, Packaging, and Orderable Information</b> .....	27
<b>6 Parameter Measurement Information</b> .....	18		

### 4 Pin Configuration and Functions

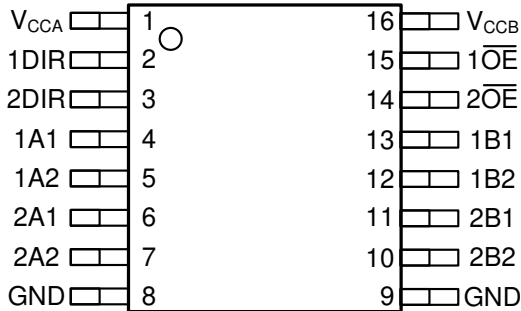

Figure 4-1. PW Package, 16-Pin TSSOP (Top View)

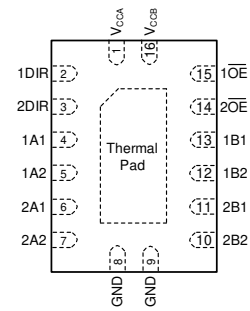

Figure 4-2. BQB/WBQB Package, 16-Pin WQFN (Transparent Top View)

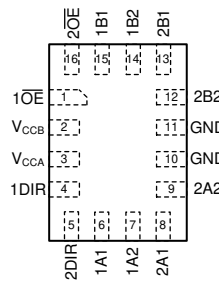

Figure 4-3. RSV Package, 16-Pin UQFN (Transparent Top View)

Table 4-1. Pin Functions

PIN NAME	NO.			TYPE <sup>(1)</sup>	DESCRIPTION
	PW	RSV	BQB		
1A1	4	6	4	I/O	Input/output 1A1. Referenced to V <sub>CCA</sub>
1A2	5	7	5	I/O	Input/output 1A2. Referenced to V <sub>CCA</sub>
1B1	13	15	13	I/O	Input/output 1B1. Referenced to V <sub>CCB</sub>
1B2	12	14	12	I/O	Input/output 1B2. Referenced to V <sub>CCB</sub>
1DIR	2	4	2	I	Direction-control input for '1' ports. Referenced to V <sub>CCA</sub>
1 OE	15	1	15	I	Tri-state output-mode enable. Pull OE high to place '1' outputs in tri-state mode. Referenced to V <sub>CCA</sub>
2A1	6	8	6	I/O	Input/output 2A1. Referenced to V <sub>CCA</sub>
2A2	7	9	7	I/O	Input/output 2A2. Referenced to V <sub>CCA</sub>
2B1	11	13	11	I/O	Input/output 2B1. Referenced to V <sub>CCB</sub>
2B2	10	12	10	I/O	Input/output 2B2. Referenced to V <sub>CCB</sub>
2DIR	3	5	3	I	Direction-control input for '2' ports. Referenced to V <sub>CCA</sub>
2 OE	14	16	14	I	Tri-state output-mode enable. Pull OE high to place '2' outputs in tri-state mode. Referenced to V <sub>CCA</sub>
GND	8, 9	10, 11	8, 9	—	Ground
V <sub>CCA</sub>	1	3	1	—	A-port power supply voltage. 0.65V ≤ V <sub>CCA</sub> ≤ 3.6V
V <sub>CCB</sub>	16	2	16	—	B-port power supply voltage. 0.65V ≤ V <sub>CCB</sub> ≤ 3.6V

(1) I = input, O = output

## 5 Specifications

### 5.1 Absolute Maximum Ratings

over operating free-air temperature range (unless otherwise noted)<sup>(1)</sup>

			MIN	MAX	UNIT
V <sub>CCA</sub>	Supply voltage A		-0.5	4.2	V
V <sub>CCB</sub>	Supply voltage B		-0.5	4.2	V
V <sub>I</sub>	Input Voltage <sup>(2)</sup>	I/O Ports (A Port)	-0.5	4.2	V
		I/O Ports (B Port)	-0.5	4.2	
		Control Inputs	-0.5	4.2	
V <sub>O</sub>	Voltage applied to any output in the high-impedance or power-off state <sup>(2)</sup>	A Port	-0.5	4.2	V
		B Port	-0.5	4.2	
V <sub>O</sub>	Voltage applied to any output in the high or low state <sup>(2) (3)</sup>	A Port	-0.5 V <sub>CCA</sub> + 0.2		V
		B Port	-0.5 V <sub>CCB</sub> + 0.2		
I <sub>IK</sub>	Input clamp current	V <sub>I</sub> < 0	-50		mA
I <sub>OK</sub>	Output clamp current	V <sub>O</sub> < 0	-50		mA
I <sub>O</sub>	Continuous output current		-50	50	mA
	Continuous current through V <sub>CC</sub> or GND		-100	100	mA
T <sub>J</sub>	Junction Temperature			150	°C
T <sub>stg</sub>	Storage temperature		-65	150	°C

- (1) Stresses beyond those listed under *Absolute Maximum Ratings* may cause permanent damage to the device. These are stress ratings only, which do not imply functional operation of the device at these or any other conditions beyond those indicated under *Recommended Operating Conditions*. Exposure to absolute-maximum-rated conditions for extended periods may affect device reliability.
- (2) The input voltage and output negative-voltage ratings may be exceeded if the input and output current ratings are observed.
- (3) The output positive-voltage rating may be exceeded up to 4.2V maximum if the output current rating is observed.

### 5.2 ESD Ratings

			VALUE	UNIT
V <sub>(ESD)</sub>	Electrostatic discharge	Human body model (HBM), per AEC Q100-002 <sup>(1)</sup>	±8000	V
		Charged device model (CDM), per AEC Q100-011	±1000	

- (1) AEC Q100-002 indicates that HBM stressing shall be in accordance with the ANSI/ESDA/JEDEC JS-001 specification.

### 5.3 Recommended Operating Conditions

over operating free-air temperature range (unless otherwise noted)<sup>(1) 2</sup>

			MIN	MAX	UNIT
V <sub>CCA</sub>	Supply voltage A		0.65	3.6	V
V <sub>CCB</sub>	Supply voltage B		0.65	3.6	V
V <sub>IH</sub>	High-level input voltage	Data Inputs	V <sub>CCI</sub> = 0.65V - 0.75V	V <sub>CCI</sub> × 0.70	V
			V <sub>CCI</sub> = 0.76V - 1V	V <sub>CCI</sub> × 0.70	
			V <sub>CCI</sub> = 1.1V - 1.95V	V <sub>CCI</sub> × 0.65	
			V <sub>CCI</sub> = 2.3V - 2.7V	1.6	
			V <sub>CCI</sub> = 3V - 3.6V	2	
		Control Inputs(xDIR, xOE) Referenced to V <sub>CCA</sub>	V <sub>CCA</sub> = 0.65V - 0.75V	V <sub>CCA</sub> × 0.70	
			V <sub>CCA</sub> = 0.76V - 1V	V <sub>CCA</sub> × 0.70	
			V <sub>CCA</sub> = 1.1V - 1.95V	V <sub>CCA</sub> × 0.65	
			V <sub>CCA</sub> = 2.3V - 2.7V	1.6	
			V <sub>CCA</sub> = 3V - 3.6V	2	
V <sub>IL</sub>	Low-level input voltage	Data Inputs	V <sub>CCI</sub> = 0.65V - 0.75V	V <sub>CCI</sub> × 0.30	V
			V <sub>CCI</sub> = 0.76V - 1V	V <sub>CCI</sub> × 0.30	
			V <sub>CCI</sub> = 1.1V - 1.95V	V <sub>CCI</sub> × 0.35	
			V <sub>CCI</sub> = 2.3V - 2.7V	0.7	
			V <sub>CCI</sub> = 3V - 3.6V	0.8	
		Control Inputs(xDIR, xOE) Referenced to V <sub>CCA</sub>	V <sub>CCA</sub> = 0.65V - 0.75V	V <sub>CCA</sub> × 0.30	
			V <sub>CCA</sub> = 0.76V - 1V	V <sub>CCA</sub> × 0.30	
			V <sub>CCA</sub> = 1.1V - 1.95V	V <sub>CCA</sub> × 0.35	
			V <sub>CCA</sub> = 2.3V - 2.7V	0.7	
			V <sub>CCA</sub> = 3V - 3.6V	0.8	
V <sub>I</sub>	Input voltage <sup>1</sup>		0	3.6	V
V <sub>O</sub>	Output voltage	Active State	0	V <sub>CCO</sub>	V
		Tri-State	0	3.6	
Δt/Δv <sup>2</sup>	Input transition rate			10	ns/V
T <sub>A</sub>	Operating free-air temperature		-40	125	°C

(1) V<sub>CCI</sub> is the V<sub>CC</sub> associated with the input port. V<sub>CCO</sub> is the V<sub>CC</sub> associated with the output port.

(2) All unused inputs of the device must be held at VCC or GND for proper device operation. Refer to the TI application report, [Implications of Slow or Floating CMOS Inputs](#).

### 5.4 Thermal Information

THERMAL METRIC <sup>(1)</sup>		SN74AXC4T245-Q1				UNIT
		PW (TSSOP)	RSV (UQFN)	BQB (WQFN)	WBQB (WQFN)	
		16 PINS	16 PINS	16 PINS	16 PINS	
R <sub>θJA</sub>	Junction-to-ambient thermal resistance	126.9	130.1	73.0	72.9	°C/W
R <sub>θJC(top)</sub>	Junction-to-case (top) thermal resistance	49.3	70.3	35.1	69.6	°C/W
R <sub>θJB</sub>	Junction-to-board thermal resistance	74.3	57.4	42.8	41.9	°C/W
ψ <sub>JT</sub>	Junction-to-top characterization parameter	8.1	4.6	4.6	4.6	°C/W
ψ <sub>JB</sub>	Junction-to-board characterization parameter	73.4	55.8	42.8	41.9	°C/W
R <sub>θJC(bottom)</sub>	Junction-to-case (bottom) thermal resistance	NA	NA	10.2	19.9	°C/W

(1) For more information about traditional and new thermal metrics, see the [Semiconductor and IC Package Thermal Metrics](#) application report.

## 5.5 Electrical Characteristics

over operating free-air temperature range (unless otherwise noted) <sup>(1)</sup> <sup>(2)</sup>

PARAMETER	TEST CONDITIONS	$V_{CCA}$	$V_{CCB}$	Operating free-air temperature ( $T_A$ )						UNIT	
				–40°C to 85°C			–40°C to 125°C				
				MIN	TYP <sup>(4)</sup>	MAX	MIN	TYP <sup>(4)</sup>	MAX		
$V_{OH}$	High-level output voltage	$V_I = V_{IH}$		0.7V - 3.6V	0.7V - 3.6V	$V_{CCO} - 0.1$		$V_{CCO} - 0.1$		V	
						$I_{OH} = -100\mu A$	0.65V	0.65V	0.55		0.55
						$I_{OH} = -50\mu A$	0.76V	0.76V	0.58		0.58
						$I_{OH} = -200\mu A$	0.85V	0.85V	0.65		0.65
						$I_{OH} = -3mA$	1.1V	1.1V	0.85		0.85
						$I_{OH} = -6mA$	1.4V	1.4V	1.05		1.05
						$I_{OH} = -8mA$	1.65V	1.65V	1.2		1.2
						$I_{OH} = -9mA$	2.3V	2.3V	1.75		1.75
						$I_{OH} = -12mA$	3V	3V	2.3		2.3
$V_{OL}$	Low-level output voltage	$V_I = V_{IL}$		0.7V - 3.6V	0.7V - 3.6V					V	
						$I_{OL} = 100\mu A$	0.65V	0.65V	0.1		0.1
						$I_{OL} = 50\mu A$	0.76V	0.76V	0.18		0.18
						$I_{OL} = 200\mu A$	0.85V	0.85V	0.2		0.2
						$I_{OL} = 500\mu A$	1.1V	1.1V	0.25		0.25
						$I_{OL} = 3mA$	1.4V	1.4V	0.35		0.35
						$I_{OL} = 6mA$	1.65V	1.65V	0.45		0.45
						$I_{OL} = 8mA$	2.3V	2.3V	0.55		0.55
						$I_{OL} = 9mA$	3V	3V	0.7		0.7
$I_I$	Input leakage current	Control inputs (xDIR, xOE): $V_I = V_{CCA}$ or GND		0.65V- 3.6V	0.65V- 3.6V	–0.5	0.5	–1	1	$\mu A$	
		Data Inputs (xAx, xBx): $V_I = V_{CCI}$ or GND		0.65V- 3.6V	0.65V- 3.6V	–4	4	–8	8	$\mu A$	
$I_{off}$	Partial power down current	A or B Port		0V	0V - 3.6V	–4	4	–8	8	$\mu A$	
		$V_I$ or $V_O = 0V - 3.6V$		0V - 3.6V	0V	–4	4	–8	8		
$I_{OZ}$	Tri-state output current <sup>(3)</sup>	A or B Port $V_I = V_{CCI}$ or GND, $V_O = V_{CCO}$ or GND, $\overline{OE} = V_{IH}$		3.6V	3.6V	–4	4	–8	8	$\mu A$	
$I_{CCA}$	$V_{CCA}$ supply current	$V_I = V_{CCI}$ or GND	$I_O = 0$	0.65V- 3.6V	0.65V- 3.6V			13		$\mu A$	
				0V	3.6V	–2		–12			
				3.6V	0V			8	16		
$I_{CCB}$	$V_{CCB}$ supply current	$V_I = V_{CCI}$ or GND	$I_O = 0$	0.65V- 3.6V	0.65V- 3.6V			13		$\mu A$	
				0V	3.6V			8	16		
				3.6V	0V	–2		–12			
$I_{CCA} + I_{CCB}$	Combined supply current	$V_I = V_{CCI}$ or GND	$I_O = 0$	0.65V- 3.6V	0.65V- 3.6V			20		$\mu A$	
$C_i$	Control input capacitance	$V_I = 3.3V$ or GND		3.3V	3.3V			4.5		pF	
$C_{io}$	Data I/O capacitance	$\overline{OE} = V_{CCA}$ , $V_O = 1.65V$ DC +1MHz -16dBm sine wave		3.3V	3.3V			6.6		pF	

- (1)  $V_{CCI}$  is the  $V_{CC}$  associated with the input port.
- (2)  $V_{CCO}$  is the  $V_{CC}$  associated with the output port.
- (3) For I/O ports, the parameter  $I_{OZ}$  includes the input leakage current.
- (4) All typical data is taken at 25°C.

### 5.6 Switching Characteristics, $V_{CCA} = 0.7V \pm 0.05V$

See [Figure 1](#) and [Table 1](#) for test circuit and loading. See [Figure 2](#), [Figure 3](#), and [Figure 4](#) for measurement waveforms.

PARAMETER		FROM	TO	Test Conditions	B-Port Supply Voltage ( $V_{CCB}$ )														UNIT		
					0.7 ± 0.05V		0.8 ± 0.04V		0.9 ± 0.045V		1.2 ± 0.1V		1.5 ± 0.1V		1.8 ± 0.15V		2.5 ± 0.2V			3.3 ± 0.3V	
					MIN	MAX	MIN	MAX	MIN	MAX	MIN	MAX	MIN	MAX	MIN	MAX	MIN	MAX		MIN	MAX
$t_{pd}$	Propagation delay	A	B	-40°C to 85°C	0.5	155	0.5	108	0.5	76	0.5	40	0.5	37	0.5	40	0.5	67	0.5	185	ns
				-40°C to 125°C	0.5	155	0.5	108	0.5	76	0.5	40	0.5	37	0.5	40	0.5	67	0.5	185	
		B	A	-40°C to 85°C	0.5	156	0.5	128	0.5	106	0.5	55	0.5	21	0.5	15	0.5	11	0.5	10	
				-40°C to 125°C	0.5	156	0.5	128	0.5	106	0.5	55	0.5	21	0.5	15	0.5	11	0.5	10	
$t_{dis}$	Disable time	$\overline{OE}$	A	-40°C to 85°C	0.5	156	0.5	156	0.5	156	0.5	156	0.5	156	0.5	156	0.5	156	0.5	156	ns
				-40°C to 125°C	0.5	156	0.5	156	0.5	156	0.5	156	0.5	156	0.5	156	0.5	156	0.5	156	
		$\overline{OE}$	B	-40°C to 85°C	0.5	154	0.5	121	0.5	101	0.5	55	0.5	54	0.5	56	0.5	65	0.5	125	
				-40°C to 125°C	0.5	154	0.5	121	0.5	101	0.5	55	0.5	54	0.5	56	0.5	65	0.5	125	
$t_{en}$	Enable time	$\overline{OE}$	A	-40°C to 85°C	0.5	238	0.5	238	0.5	238	0.5	238	0.5	238	0.5	238	0.5	238	0.5	238	ns
				-40°C to 125°C	0.5	238	0.5	238	0.5	238	0.5	238	0.5	238	0.5	238	0.5	238	0.5	238	
		$\overline{OE}$	B	-40°C to 85°C	0.5	286	0.5	194	0.5	146	0.5	94	0.5	76	0.5	70	0.5	69	0.5	146	
				-40°C to 125°C	0.5	286	0.5	194	0.5	146	0.5	94	0.5	76	0.5	70	0.5	69	0.5	146	

## 5.7 Switching Characteristics, $V_{CCA} = 0.8V \pm 0.04V$

See [Figure 1](#) and [Table 1](#) for test circuit and loading. See [Figure 2](#), [Figure 3](#), and [Figure 4](#) for measurement waveforms.

PARAMETER	FROM	TO	Test Conditions	B-Port Supply Voltage ( $V_{CCB}$ )														UNIT			
				0.7 ± 0.05V		0.8 ± 0.04V		0.9 ± 0.045V		1.2 ± 0.1V		1.5 ± 0.1V		1.8 ± 0.15V		2.5 ± 0.2V			3.3 ± 0.3V		
				MIN	MAX	MIN	MAX	MIN	MAX	MIN	MAX	MIN	MAX	MIN	MAX	MIN	MAX		MIN	MAX	
$t_{pd}$	Propagation delay	A	B	-40°C to 85°C	0.5	128	0.5	88	0.5	63	0.5	29	0.5	24	0.5	23	0.5	24	0.5	34	ns
				-40°C to 125°C	0.5	128	0.5	88	0.5	63	0.5	29	0.5	24	0.5	23	0.5	24	0.5	34	
	B	A	-40°C to 85°C	0.5	108	0.5	88	0.5	70	0.5	38	0.5	21	0.5	15	0.5	11	0.5	10		
			-40°C to 125°C	0.5	108	0.5	88	0.5	70	0.5	38	0.5	21	0.5	15	0.5	11	0.5	10		
$t_{dis}$	Disable time	$\overline{OE}$	A	-40°C to 85°C	0.5	103	0.5	103	0.5	103	0.5	103	0.5	103	0.5	103	0.5	103	0.5	103	ns
				-40°C to 125°C	0.5	103	0.5	103	0.5	103	0.5	103	0.5	103	0.5	103	0.5	103	0.5	103	
		$\overline{OE}$	B	-40°C to 85°C	0.5	143	0.5	110	0.5	90	0.5	42	0.5	36	0.5	36	0.5	37	0.5	47	
				-40°C to 125°C	0.5	143	0.5	110	0.5	90	0.5	42	0.5	36	0.5	36	0.5	37	0.5	47	
$t_{en}$	Enable time	$\overline{OE}$	A	-40°C to 85°C	0.5	143	0.5	143	0.5	143	0.5	143	0.5	143	0.5	143	0.5	143	0.5	143	ns
				-40°C to 125°C	0.5	143	0.5	143	0.5	143	0.5	143	0.5	143	0.5	143	0.5	143	0.5	143	
		$\overline{OE}$	B	-40°C to 85°C	0.5	243	0.5	172	0.5	129	0.5	79	0.5	60	0.5	54	0.5	48	0.5	53	
				-40°C to 125°C	0.5	243	0.5	172	0.5	129	0.5	79	0.5	60	0.5	54	0.5	48	0.5	53	

### 5.8 Switching Characteristics, $V_{CCA} = 0.9V \pm 0.045V$

See [Figure 1](#) and [Table 1](#) for test circuit and loading. See [Figure 2](#), [Figure 3](#), and [Figure 4](#) for measurement waveforms.

PARAMETER		FROM	TO	Test Conditions	B-Port Supply Voltage ( $V_{CCB}$ )														UNIT		
					0.7 ± 0.05V		0.8 ± 0.04V		0.9 ± 0.045V		1.2 ± 0.1V		1.5 ± 0.1V		1.8 ± 0.15V		2.5 ± 0.2V			3.3 ± 0.3V	
					MIN	MAX	MIN	MAX	MIN	MAX	MIN	MAX	MIN	MAX	MIN	MAX	MIN	MAX		MIN	MAX
$t_{pd}$	Propagation delay	A	B	-40°C to 85°C	0.5	106	0.5	70	0.5	53	0.5	24	0.5	18	0.5	17	0.5	16	0.5	19	ns
				-40°C to 125°C	0.5	106	0.5	70	0.5	53	0.5	24	0.5	18	0.5	17	0.5	16	0.5	19	
		B	A	-40°C to 85°C	0.5	76	0.5	63	0.5	53	0.5	27	0.5	18	0.5	13	0.5	10	0.5	9	
				-40°C to 125°C	0.5	76	0.5	63	0.5	53	0.5	27	0.5	18	0.5	13	0.5	10	0.5	9	
$t_{dis}$	Disable time	$\overline{OE}$	A	-40°C to 85°C	0.5	81	0.5	81	0.5	81	0.5	81	0.5	81	0.5	81	0.5	81	0.5	81	ns
				-40°C to 125°C	0.5	81	0.5	81	0.5	81	0.5	81	0.5	81	0.5	81	0.5	81	0.5	81	
		$\overline{OE}$	B	-40°C to 85°C	0.5	138	0.5	105	0.5	84	0.5	37	0.5	30	0.5	28	0.5	26	0.5	30	
				-40°C to 125°C	0.5	138	0.5	105	0.5	84	0.5	37	0.5	30	0.5	28	0.5	26	0.5	30	
$t_{en}$	Enable time	$\overline{OE}$	A	-40°C to 85°C	0.5	95	0.5	95	0.5	95	0.5	95	0.5	95	0.5	95	0.5	95	0.5	95	ns
				-40°C to 125°C	0.5	95	0.5	95	0.5	95	0.5	95	0.5	95	0.5	95	0.5	95	0.5	95	
		$\overline{OE}$	B	-40°C to 85°C	0.5	222	0.5	148	0.5	116	0.5	71	0.5	52	0.5	46	0.5	39	0.5	39	
				-40°C to 125°C	0.5	222	0.5	148	0.5	116	0.5	71	0.5	52	0.5	46	0.5	39	0.5	39	

## 5.9 Switching Characteristics, $V_{CCA} = 1.2V \pm 0.1V$

See [Figure 1](#) and [Table 1](#) for test circuit and loading. See [Figure 2](#), [Figure 3](#), and [Figure 4](#) for measurement waveforms.

PARAMETER	FROM	TO	Test Conditions	B-Port Supply Voltage ( $V_{CCB}$ )												UNIT					
				0.7 ± 0.05V		0.8 ± 0.04V		0.9 ± 0.045V		1.2 ± 0.1V		1.5 ± 0.1V		1.8 ± 0.15V			2.5 ± 0.2V		3.3 ± 0.3V		
				MIN	MAX	MIN	MAX	MIN	MAX	MIN	MAX	MIN	MAX	MIN	MAX		MIN	MAX	MIN	MAX	
$t_{pd}$	Propagation delay	A	B	-40°C to 85°C	0.5	55	0.5	37	0.5	27	0.5	15	0.5	11	0.5	10	0.5	8	0.5	9	ns
				-40°C to 125°C	0.5	55	0.5	37	0.5	27	0.5	15	0.5	11	0.5	10	0.5	8	0.5	9	
	B	A	-40°C to 85°C	0.5	41	0.5	29	0.5	24	0.5	15	0.5	10	0.5	9	0.5	7	0.5	6		
			-40°C to 125°C	0.5	41	0.5	29	0.5	24	0.5	15	0.5	10	0.5	9	0.5	7	0.5	6		
$t_{dis}$	Disable time	$\overline{OE}$	A	-40°C to 85°C	0.5	30	0.5	30	0.5	30	0.5	30	0.5	30	0.5	30	0.5	30	0.5	30	ns
				-40°C to 125°C	0.5	30	0.5	30	0.5	30	0.5	30	0.5	30	0.5	30	0.5	30	0.5	30	
	$\overline{OE}$	B	-40°C to 85°C	0.5	132	0.5	99	0.5	79	0.5	31	0.5	24	0.5	21	0.5	18	0.5	18		
			-40°C to 125°C	0.5	132	0.5	99	0.5	79	0.5	31	0.5	24	0.5	21	0.5	18	0.5	18		
$t_{en}$	Enable time	$\overline{OE}$	A	-40°C to 85°C	0.5	45	0.5	45	0.5	45	0.5	45	0.5	45	0.5	45	0.5	45	0.5	45	ns
				-40°C to 125°C	0.5	45	0.5	45	0.5	45	0.5	45	0.5	45	0.5	45	0.5	45	0.5	45	
	$\overline{OE}$	B	-40°C to 85°C	0.5	164	0.5	108	0.5	79	0.5	58	0.5	41	0.5	35	0.5	27	0.5	24		
			-40°C to 125°C	0.5	164	0.5	108	0.5	79	0.5	58	0.5	41	0.5	35	0.5	27	0.5	24		

### 5.10 Switching Characteristics, $V_{CCA} = 1.5V \pm 0.1V$

See [Figure 1](#) and [Table 1](#) for test circuit and loading. See [Figure 2](#), [Figure 3](#), and [Figure 4](#) for measurement waveforms.

PARAMETER	FROM	TO	Test Conditions	B-Port Supply Voltage ( $V_{CCB}$ )														UNIT			
				0.7 ± 0.05V		0.8 ± 0.04V		0.9 ± 0.045V		1.2 ± 0.1V		1.5 ± 0.1V		1.8 ± 0.15V		2.5 ± 0.2V			3.3 ± 0.3V		
				MIN	MAX	MIN	MAX	MIN	MAX	MIN	MAX	MIN	MAX	MIN	MAX	MIN	MAX		MIN	MAX	
$t_{pd}$	Propagation delay	A	B	-40°C to 85°C	0.5	21	0.5	21	0.5	18	0.5	11	0.5	9	0.5	8	0.5	7	0.5	6	ns
				-40°C to 125°C	0.5	21	0.5	21	0.5	18	0.5	11	0.5	9	0.5	8	0.5	7	0.5	6	
		B	A	-40°C to 85°C	0.5	37	0.5	24	0.5	18	0.5	11	0.5	9	0.5	8	0.5	5	0.5	5	
				-40°C to 125°C	0.5	37	0.5	24	0.5	18	0.5	11	0.5	9	0.5	8	0.5	5	0.5	5	
$t_{dis}$	Disable time	$\overline{OE}$	A	-40°C to 85°C	0.5	21	0.5	21	0.5	21	0.5	21	0.5	21	0.5	21	0.5	21	0.5	21	ns
				-40°C to 125°C	0.5	21	0.5	21	0.5	21	0.5	21	0.5	21	0.5	21	0.5	21	0.5	21	
		$\overline{OE}$	B	-40°C to 85°C	0.5	131	0.5	97	0.5	77	0.5	29	0.5	21	0.5	19	0.5	15	0.5	15	
				-40°C to 125°C	0.5	131	0.5	97	0.5	77	0.5	29	0.5	21	0.5	19	0.5	15	0.5	15	
$t_{en}$	Enable time	$\overline{OE}$	A	-40°C to 85°C	0.5	26	0.5	26	0.5	26	0.5	26	0.5	26	0.5	26	0.5	26	0.5	26	ns
				-40°C to 125°C	0.5	26	0.5	26	0.5	26	0.5	26	0.5	26	0.5	26	0.5	26	0.5	26	
		$\overline{OE}$	B	-40°C to 85°C	0.5	109	0.5	84	0.5	68	0.5	47	0.5	35	0.5	29	0.5	22	0.5	20	
				-40°C to 125°C	0.5	109	0.5	84	0.5	68	0.5	47	0.5	35	0.5	29	0.5	22	0.5	20	

## 5.11 Switching Characteristics, $V_{CCA} = 1.8V \pm 0.15V$

See [Figure 1](#) and [Table 1](#) for test circuit and loading. See [Figure 2](#), [Figure 3](#), and [Figure 4](#) for measurement waveforms.

PARAMETER	FROM	TO	Test Conditions	B-Port Supply Voltage ( $V_{CCB}$ )												UNIT						
				0.7 ± 0.05V		0.8 ± 0.04V		0.9 ± 0.045V		1.2 ± 0.1V		1.5 ± 0.1V		1.8 ± 0.15V			2.5 ± 0.2V		3.3 ± 0.3V			
				MIN	MAX	MIN	MAX	MIN	MAX	MIN	MAX	MIN	MAX	MIN	MAX		MIN	MAX	MIN	MAX		
$t_{pd}$	Propagation delay	A	B	-40°C to 85°C	0.5	15	0.5	15	0.5	13	0.5	9	0.5	8	0.5	7	0.5	6	0.5	6	ns	
				-40°C to 125°C	0.5	15	0.5	15	0.5	13	0.5	9	0.5	8	0.5	7	0.5	6	0.5	6		
	B	A	-40°C to 85°C	0.5	40	0.5	23	0.5	17	0.5	10	0.5	8	0.5	7	0.5	5	0.5	4	ns		
			-40°C to 125°C	0.5	40	0.5	23	0.5	17	0.5	10	0.5	8	0.5	7	0.5	5	0.5	4			
$t_{dis}$	Disable time	$\overline{OE}$	A	-40°C to 85°C	0.5	18	0.5	18	0.5	18	0.5	18	0.5	18	0.5	18	0.5	18	0.5	18	ns	
				-40°C to 125°C	0.5	18	0.5	18	0.5	18	0.5	18	0.5	18	0.5	18	0.5	18	0.5	18		
		$\overline{OE}$	B	-40°C to 85°C	0.5	130	0.5	96	0.5	76	0.5	28	0.5	21	0.5	18	0.5	15	0.5	14		ns
				-40°C to 125°C	0.5	130	0.5	96	0.5	76	0.5	28	0.5	21	0.5	18	0.5	15	0.5	14		
$t_{en}$	Enable time	$\overline{OE}$	A	-40°C to 85°C	0.5	20	0.5	20	0.5	20	0.5	20	0.5	20	0.5	20	0.5	20	0.5	20	ns	
				-40°C to 125°C	0.5	20	0.5	20	0.5	20	0.5	20	0.5	20	0.5	20	0.5	20	0.5	20		
		$\overline{OE}$	B	-40°C to 85°C	0.5	102	0.5	75	0.5	62	0.5	41	0.5	32	0.5	27	0.5	20	0.5	18		ns
				-40°C to 125°C	0.5	102	0.5	75	0.5	62	0.5	41	0.5	32	0.5	27	0.5	20	0.5	18		

## 5.12 Switching Characteristics, $V_{CCA} = 2.5V \pm 0.2V$

See [Figure 1](#) and [Table 1](#) for test circuit and loading. See [Figure 2](#), [Figure 3](#), and [Figure 4](#) for measurement waveforms.

PARAMETER	FROM	TO	Test Conditions	B-Port Supply Voltage ( $V_{CCB}$ )														UNIT				
				0.7 ± 0.05V		0.8 ± 0.04V		0.9 ± 0.045V		1.2 ± 0.1V		1.5 ± 0.1V		1.8 ± 0.15V		2.5 ± 0.2V			3.3 ± 0.3V			
				MIN	MAX	MIN	MAX	MIN	MAX	MIN	MAX	MIN	MAX	MIN	MAX	MIN	MAX		MIN	MAX		
$t_{pd}$	Propagation delay	A	B	-40°C to 85°C	0.5	11	0.5	11	0.5	10	0.5	7	0.5	5	0.5	5	0.5	5	0.5	5	ns	
				-40°C to 125°C	0.5	11	0.5	11	0.5	11	0.5	7	0.5	5	0.5	5	0.5	5	0.5	5		
	B	A	-40°C to 85°C	0.5	67	0.5	24	0.5	16	0.5	8	0.5	7	0.5	6	0.5	5	0.5	5	0.5		4
			-40°C to 125°C	0.5	67	0.5	24	0.5	16	0.5	8	0.5	7	0.5	6	0.5	5	0.5	5	0.5		4
$t_{dis}$	Disable time	$\overline{OE}$	A	-40°C to 85°C	0.5	13	0.5	13	0.5	13	0.5	13	0.5	13	0.5	13	0.5	13	0.5	13	ns	
				-40°C to 125°C	0.5	13	0.5	13	0.5	13	0.5	13	0.5	13	0.5	13	0.5	13	0.5	13		
	$\overline{OE}$	B	-40°C to 85°C	0.5	128	0.5	95	0.5	76	0.5	27	0.5	20	0.5	17	0.5	13	0.5	13	0.5		13
			-40°C to 125°C	0.5	128	0.5	95	0.5	76	0.5	27	0.5	20	0.5	17	0.5	13	0.5	13	0.5		13
$t_{en}$	Enable time	$\overline{OE}$	A	-40°C to 85°C	0.5	13	0.5	13	0.5	13	0.5	13	0.5	13	0.5	13	0.5	13	0.5	13	ns	
				-40°C to 125°C	0.5	13	0.5	13	0.5	13	0.5	13	0.5	13	0.5	13	0.5	13	0.5	13		
	$\overline{OE}$	B	-40°C to 85°C	0.5	120	0.5	70	0.5	56	0.5	36	0.5	26	0.5	22	0.5	18	0.5	16	0.5		16
			-40°C to 125°C	0.5	120	0.5	70	0.5	56	0.5	36	0.5	26	0.5	22	0.5	18	0.5	16	0.5		16

### 5.13 Switching Characteristics, $V_{CCA} = 3.3V \pm 0.3V$

See Figure 1 and Table 1 for test circuit and loading. See Figure 2, Figure 3, and Figure 4 for measurement waveforms.

PARAMETER	FROM	TO	Test Conditions	B-Port Supply Voltage ( $V_{CCB}$ )														UNIT					
				0.7 ± 0.05V		0.8 ± 0.04V		0.9 ± 0.045V		1.2 ± 0.1V		1.5 ± 0.1V		1.8 ± 0.15V		2.5 ± 0.2V			3.3 ± 0.3V				
				MIN	MAX	MIN	MAX	MIN	MAX	MIN	MAX	MIN	MAX	MIN	MAX	MIN	MAX		MIN	MAX			
$t_{pd}$	Propagation delay	A	B	-40°C to 85°C	0.5	10	0.5	10	0.5	9	0.5	6	0.5	5	0.5	4	0.5	4	0.5	4	ns		
				-40°C to 125°C	0.5	10	0.5	10	0.5	9	0.5	6	0.5	5	0.5	4	0.5	4	0.5	4			
	B	A	-40°C to 85°C	0.5	185	0.5	34	0.5	19	0.5	9	0.5	6	0.5	6	0.5	5	0.5	4	0.5		4	
			-40°C to 125°C	0.5	185	0.5	34	0.5	19	0.5	9	0.5	6	0.5	6	0.5	5	0.5	4	0.5		4	
$t_{dis}$	Disable time	$\overline{OE}$	A	-40°C to 85°C	0.5	12	0.5	12	0.5	12	0.5	12	0.5	12	0.5	12	0.5	12	0.5	12	ns		
				-40°C to 125°C	0.5	12	0.5	12	0.5	12	0.5	12	0.5	12	0.5	12	0.5	12	0.5	12			
		$\overline{OE}$	B	-40°C to 85°C	0.5	141	0.5	95	0.5	75	0.5	27	0.5	19	0.5	17	0.5	13	0.5	12		0.5	12
				-40°C to 125°C	0.5	141	0.5	95	0.5	75	0.5	27	0.5	19	0.5	17	0.5	13	0.5	12		0.5	12
$t_{en}$	Enable time	$\overline{OE}$	A	-40°C to 85°C	0.5	11	0.5	11	0.5	11	0.5	11	0.5	11	0.5	11	0.5	11	0.5	11	ns		
				-40°C to 125°C	0.5	11	0.5	11	0.5	11	0.5	11	0.5	11	0.5	11	0.5	11	0.5	11			
		$\overline{OE}$	B	-40°C to 85°C	0.5	189	0.5	82	0.5	59	0.5	35	0.5	24	0.5	20	0.5	16	0.5	14		0.5	14
				-40°C to 125°C	0.5	189	0.5	82	0.5	59	0.5	35	0.5	24	0.5	20	0.5	16	0.5	14		0.5	14

### 5.14 Operating Characteristics: T<sub>A</sub> = 25°C

PARAMETER		TEST CONDITIONS	V <sub>CCA</sub>	V <sub>CCB</sub>	MIN	TYP	MAX	UNIT
C <sub>pdA</sub>	Power Dissipation Capacitance per transceiver (A to B: outputs enabled)	CL = 0, RL = Open f = 1MHz, tr = tf = 1ns	0.7V	0.7V		2.2		pF
			0.8V	0.8V		2.1		
			0.9V	0.9V		2.1		
			1.2V	1.2V		2.1		
			1.5V	1.5V		2.0		
			1.8V	1.8V		2.0		
			2.5V	2.5V		2.1		
			3.3V	3.3V		2.3		
	Power Dissipation Capacitance per transceiver (A to B: outputs disabled)	CL = 0, RL = Open f = 1MHz, tr = tf = 1ns	0.7V	0.7V		1.5		pF
			0.8V	0.8V		1.5		
			0.9V	0.9V		1.5		
			1.2V	1.2V		1.4		
			1.5V	1.5V		1.4		
			1.8V	1.8V		1.4		
			2.5V	2.5V		1.4		
			3.3V	3.3V		1.6		
	Power Dissipation Capacitance per transceiver (B to A: outputs enabled)	CL = 0, RL = Open f = 1MHz, tr = tf = 1ns	0.7V	0.7V		12.1		pF
			0.8V	0.8V		12.1		
			0.9V	0.9V		12.1		
			1.2V	1.2V		12.4		
			1.5V	1.5V		13.0		
			1.8V	1.8V		14.2		
			2.5V	2.5V		17.4		
			3.3V	3.3V		20.1		
	Power Dissipation Capacitance per transceiver (B to A: outputs disabled)	CL = 0, RL = Open f = 1MHz, tr = tf = 1ns	0.7V	0.7V		1.1		pF
			0.8V	0.8V		1.1		
			0.9V	0.9V		1.1		
			1.2V	1.2V		1.1		
1.5V			1.5V		1.1			
1.8V			1.8V		1.1			
2.5V			2.5V		1.1			
3.3V			3.3V		1.1			

**5.14 Operating Characteristics: T<sub>A</sub> = 25°C (continued)**

PARAMETER		TEST CONDITIONS	V <sub>CCA</sub>	V <sub>CCB</sub>	MIN	TYP	MAX	UNIT
C <sub>pdB</sub>	Power Dissipation Capacitance per transceiver (A to B: outputs enabled)	CL = 0, RL = Open f = 1MHz, tr = tf = 1ns	0.7V	0.7V		12.1		pF
			0.8V	0.8V		12.1		
			0.9V	0.9V		12.1		
			1.2V	1.2V		12.4		
			1.5V	1.5V		12.9		
			1.8V	1.8V		14.1		
			2.5V	2.5V		17.2		
			3.3V	3.3V		20.1		
	Power Dissipation Capacitance per transceiver (A to B: outputs disabled)	CL = 0, RL = Open f = 1MHz, tr = tf = 1ns	0.7V	0.7V		1.1		pF
			0.8V	0.8V		1.1		
			0.9V	0.9V		1.1		
			1.2V	1.2V		1.1		
			1.5V	1.5V		1.1		
			1.8V	1.8V		1.1		
			2.5V	2.5V		1.1		
			3.3V	3.3V		1.1		
	Power Dissipation Capacitance per transceiver (B to A: outputs enabled)	CL = 0, RL = Open f = 1MHz, tr = tf = 1ns	0.7V	0.7V		1.2		pF
			0.8V	0.8V		1.8		
			0.9V	0.9V		1.8		
			1.2V	1.2V		1.7		
			1.5V	1.5V		1.7		
			1.8V	1.8V		1.7		
			2.5V	2.5V		2		
			3.3V	3.3V		2.5		
	Power Dissipation Capacitance per transceiver (B to A: outputs disabled)	CL = 0, RL = Open f = 1MHz, tr = tf = 1ns	0.7V	0.7V		1.1		pF
			0.8V	0.8V		1.8		
			0.9V	0.9V		1.8		
			1.2V	1.2V		1.7		
1.5V			1.5V		1.7			
1.8V			1.8V		1.7			
2.5V			2.5V		2			
3.3V			3.3V		2.1			

### 5.15 Typical Characteristics

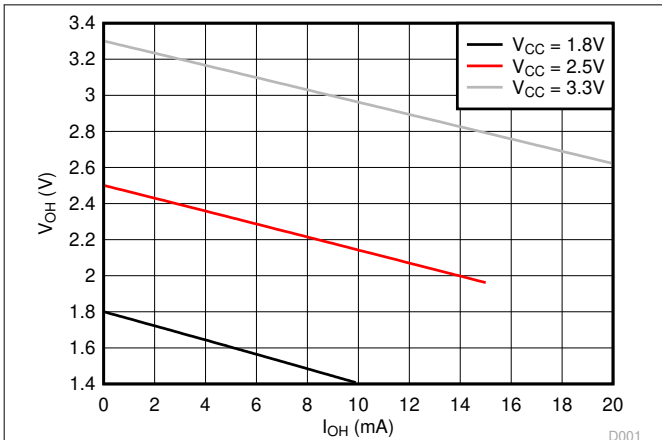

**Figure 5-1. Typical ( $T_A=25^\circ\text{C}$ ) Output High Voltage ( $V_{OH}$ ) vs Source Current ( $I_{OH}$ )**

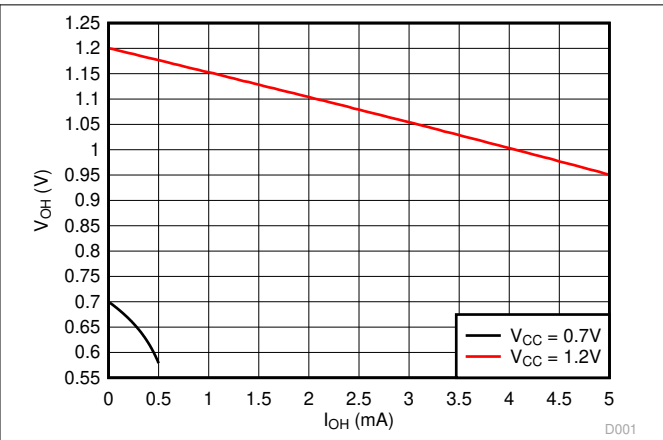

**Figure 5-2. Typical ( $T_A=25^\circ\text{C}$ ) Output High Voltage ( $V_{OH}$ ) vs Source Current ( $I_{OH}$ )**

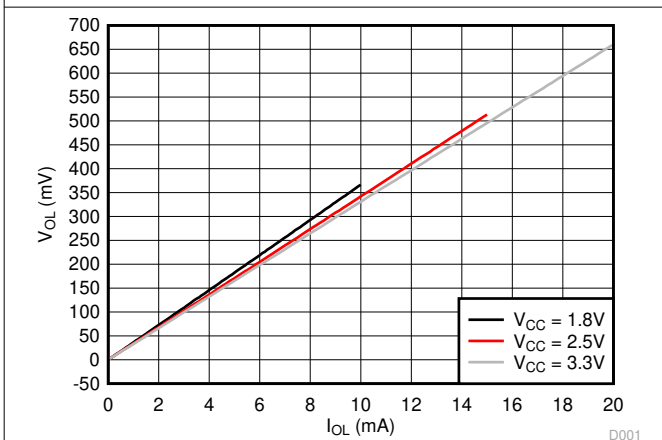

**Figure 5-3. Typical ( $T_A=25^\circ\text{C}$ ) Output Low Voltage ( $V_{OL}$ ) vs Sink Current ( $I_{OL}$ )**

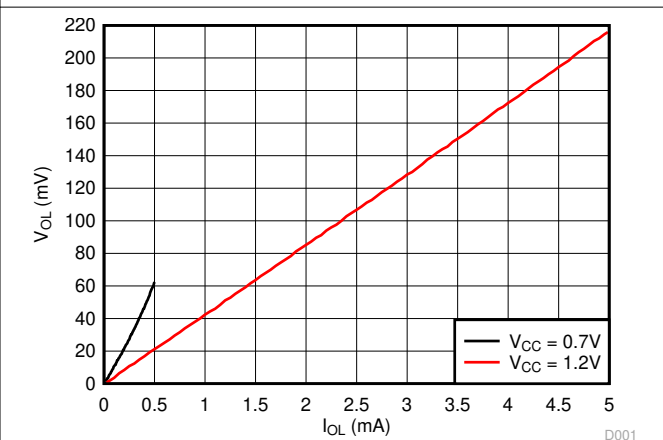

**Figure 5-4. Typical ( $T_A=25^\circ\text{C}$ ) Output Low Voltage ( $V_{OL}$ ) vs Sink Current ( $I_{OL}$ )**

## 6 Parameter Measurement Information

### 6.1 Load Circuit and Voltage Waveforms

Unless otherwise noted, all input pulses are supplied by generators having the following characteristics:

- $f = 1\text{MHz}$
- $Z_O = 50\Omega$
- $dv/dt \leq 1\text{ns/V}$

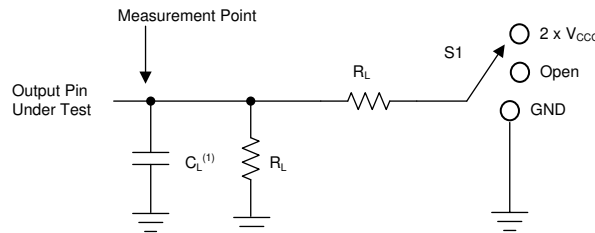

A.  $C_L$  includes probe and jig capacitance.

Figure 6-1. Load Circuit

Table 6-1. Load Circuit Conditions

Parameter	$V_{CCO}$	$R_L$	$C_L$	$S_1$	$V_{TP}$
$\Delta t/\Delta v$ Input transition rise or fall rate	0.65V – 3.6V	1M $\Omega$	15 pF	Open	N/A
$t_{pd}$ Propagation (delay) time	1.1V – 3.6V	2k $\Omega$	15 pF	Open	N/A
	0.65V – 0.95V	20k $\Omega$	15 pF	Open	N/A
$t_{en}, t_{dis}$ Enable time, disable time	3V – 3.6V	2k $\Omega$	15 pF	$2 \times V_{CCO}$	0.3V
	1.65V – 2.7V	2k $\Omega$	15 pF	$2 \times V_{CCO}$	0.15V
	1.1V – 1.6V	2k $\Omega$	15 pF	$2 \times V_{CCO}$	0.1V
	0.65V – 0.95V	20k $\Omega$	15 pF	$2 \times V_{CCO}$	0.1V
$t_{en}, t_{dis}$ Enable time, disable time	3V – 3.6V	2k $\Omega$	15 pF	GND	0.3V
	1.65V – 2.7V	2k $\Omega$	15 pF	GND	0.15V
	1.1V – 1.6V	2k $\Omega$	15 pF	GND	0.1V
	0.65V – 0.95V	20k $\Omega$	15 pF	GND	0.1V

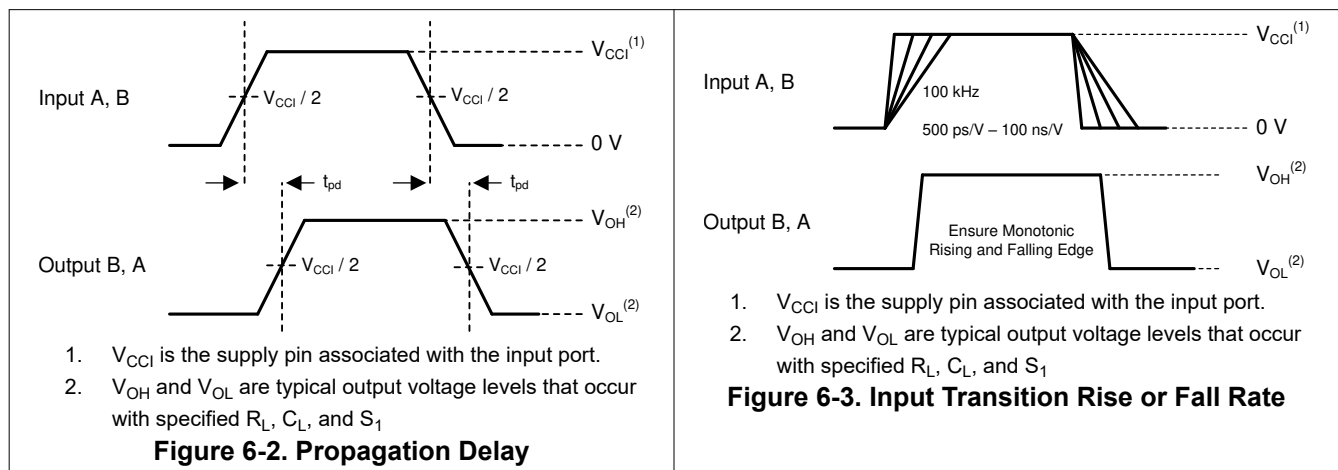

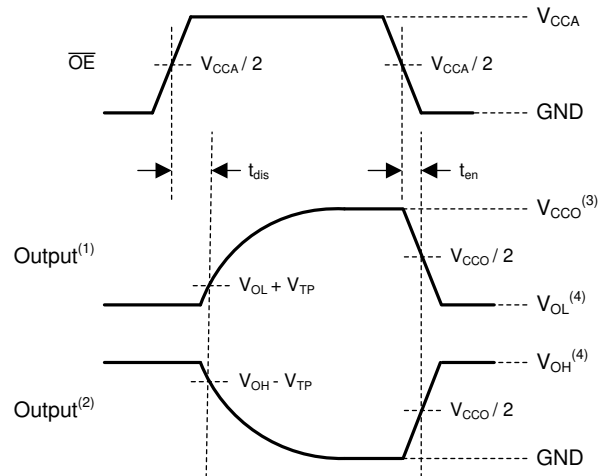

- A. Output waveform on the condition that input is driven to a valid Logic Low.
- B. Output waveform on the condition that input is driven to a valid Logic High.
- C.  $V_{CCO}$  is the supply pin associated with the output port.
- D.  $V_{OH}$  and  $V_{OL}$  are typical output voltage levels with specified  $R_L$ ,  $C_L$ , and  $S_1$ .

**Figure 6-4. Enable Time And Disable Time**

## 7 Detailed Description

### 7.1 Overview

The SN74AXC4T245-Q1 AEC-Q100 qualified device is a 4-bit, dual-supply noninverting bidirectional voltage level translation device. Ax pins and control pins (1DIR, 2DIR, 1  $\overline{OE}$ , and 2  $\overline{OE}$ ) are referenced to  $V_{CCA}$  logic levels, and Bx pins are referenced to  $V_{CCB}$  logic levels. The A port is able to accept I/O voltages ranging from 0.65V to 3.6V, while the B port can accept I/O voltages from 0.65V to 3.6V. A high on DIR allows data transmission from A to B and a low on DIR allows data transmission from B to A when  $\overline{OE}$  is set to low. When  $\overline{OE}$  is set to high, both Ax and Bx pins are in the high-impedance state. See [Device Functional Modes](#) for a summary of the operation of the control logic.

### 7.2 Functional Block Diagram

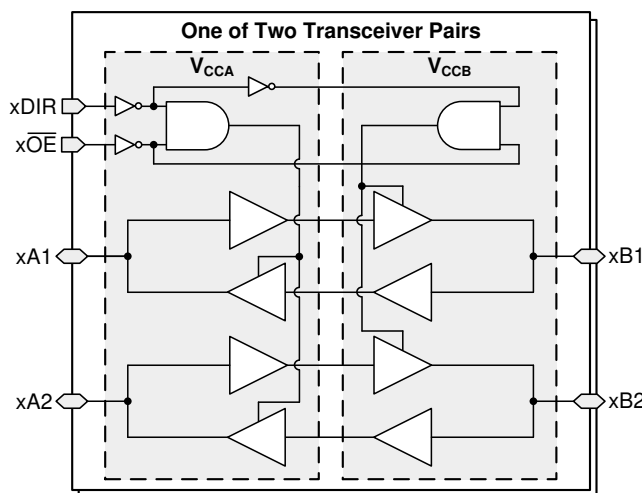

### 7.3 Feature Description

#### 7.3.1 Standard CMOS Inputs

Standard CMOS inputs are high impedance and are typically modeled as a resistor in parallel with the input capacitance given in the [Electrical Characteristics](#). The worst case resistance is calculated with the maximum input voltage, given in the [Absolute Maximum Ratings](#), and the maximum input leakage current, given in the [Electrical Characteristics](#), using ohm's law ( $R = V \div I$ ).

Signals applied to the inputs need to have fast edge rates, as defined by  $\Delta t/\Delta v$  in [Recommended Operating Conditions](#) to avoid excessive current consumption and oscillations. If a slow or noisy input signal is required, a device with a Schmitt-trigger input should be used to condition the input signal prior to the standard CMOS input.

#### 7.3.2 Balanced High-Drive CMOS Push-Pull Outputs

A balanced output allows the device to sink and source similar currents. The high drive capability of this device creates fast edges into light loads so routing and load conditions should be considered to prevent ringing. Additionally, the outputs of this device are capable of driving larger currents than the device can sustain without being damaged. The electrical and thermal limits defined in the [Absolute Maximum Ratings](#) must be followed at all times.

#### 7.3.3 Partial Power Down ( $I_{off}$ )

The inputs and outputs for this device enter a high-impedance state when the device is powered down, inhibiting current backflow into the device. The maximum leakage into or out of any input or output pin on the device is specified by  $I_{off}$  in the [Electrical Characteristics](#).

#### 7.3.4 $V_{CC}$ Isolation

The inputs and outputs for this device enter a high-impedance state when either supply is  $<100mV$ .

### 7.3.5 Over-Voltage Tolerant Inputs

Input signals to this device can be driven above the supply voltage so long as they remain below the maximum input voltage value specified in the [Recommended Operating Conditions](#).

### 7.3.6 Glitch-Free Power Supply Sequencing

Either supply rail may be powered on or off in any order without producing a glitch on the I/Os (that is, where the output erroneously transitions to VCC when it should be held low). Glitches of this nature can be misinterpreted by a peripheral as a valid data bit, which could trigger a false device reset of the peripheral, a false device configuration of the peripheral, or even a false data initialization by the peripheral. For more information regarding the power up glitch performance of the AXC family of level translators, see [Glitch Free Power Sequencing With AXC Level Translators](#).

### 7.3.7 Negative Clamping Diodes

The inputs and outputs to this device have negative clamping diodes as depicted in [Figure 7-1](#).

**CAUTION**

Voltages beyond the values specified in the [Absolute Maximum Ratings](#) table can cause damage to the device. The input negative-voltage and output voltage ratings may be exceeded if the input and output clamp-current ratings are observed.

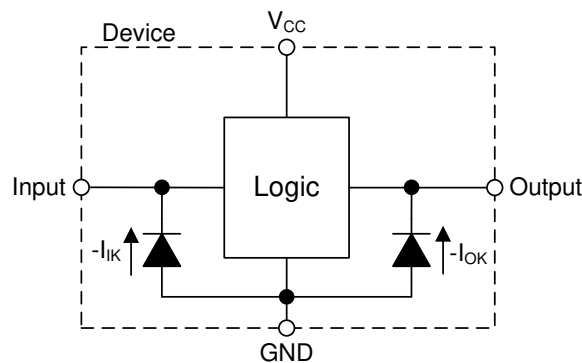

**Figure 7-1. Electrical Placement of Clamping Diodes for Each Input and Output**

### 7.3.8 Fully Configurable Dual-Rail Design

Both the  $V_{CCA}$  and  $V_{CCB}$  pins can be supplied at any voltage from 0.65V to 3.6V, making the device suitable for translating between any of the voltage nodes (0.7V, 0.8V, 0.9V, 1.2V, 1.8V, 2.5V, and 3.3V).

### 7.3.9 I/Os with Integrated Static Pull-Down Resistors

To help avoid floating inputs on the I/Os, this device has 71k $\Omega$  typical integrated weak pull-downs on all data I/Os. This feature allows all inputs to be left floating without the concern for unstable outputs or increased current consumption. This also helps to reduce external component count for applications where not all channels are used or need to be fixed low. If an external pull-up is required, it should be no larger than 7k $\Omega$  to avoid contention with the 71k $\Omega$  internal pull-down.

### 7.3.10 Supports High-Speed Translation

The SN74AXC4T245-Q1 device can support high data-rate applications. The translated signal data rate can be up to 380 Mbps when the signal is translated from 1.8V to 3.3V.

### 7.3.11 Wettable Flanks

This device includes wettable flanks for at least one package. See the *Features* section on the front page of the data sheet for which packages include this feature.

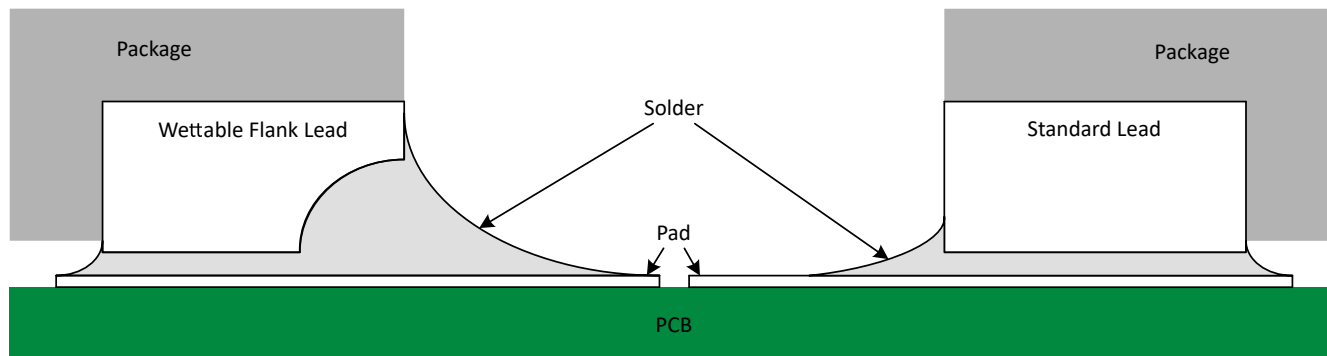

**Figure 7-2. Simplified Cutaway View of Wettable-Flank QFN Package and Standard QFN Package After Soldering**

Wettable flanks help improve side wetting after soldering, which makes QFN packages easier to inspect with automatic optical inspection (AOI). As shown in [Figure 7-2](#), a wettable flank can be dimpled or step-cut to provide additional surface area for solder adhesion which assists in reliably creating a side fillet. See the mechanical drawing for additional details.

### 7.4 Device Functional Modes

**Table 7-1. Function Table (Each 2-Bit Section)**

CONTROL INPUTS <sup>(1) (2)</sup>		PORT STATUS		OPERATION
OE	DIR	A PORT	B PORT	
L	L	Output (Enabled)	Input (Hi-Z)	B data to A bus
L	H	Input (Hi-Z)	Output (Enabled)	A data to B bus
H	X	Input (Hi-Z)	Input (Hi-Z)	Isolation

(1) Input circuits of the data I/Os are always active.

(2) Pins configured as inputs should not be left floating.

## 8 Application and Implementation

### Note

Information in the following applications sections is not part of the TI component specification, and TI does not warrant its accuracy or completeness. TI's customers are responsible for determining suitability of components for their purposes, as well as validating and testing their design implementation to confirm system functionality.

### 8.1 Application Information

The AEC-Q100 qualified SN74AXC4T245-Q1 device can be used in level-translation applications for interfacing devices or systems operating at different interface voltages with one another. The SN74AXC4T245-Q1 device is ideal for use in applications where a push-pull driver is connected to the data I/Os. The maximum data rate can be up to 380 Mbps when device translates a signal from 1.8V to 3.3V.

Figure 8-1 shows an example application where the SN74AXC4T245-Q1 device is used to translate a low voltage UART signal from an SoC to a higher voltage signal which properly drives the inputs of the Bluetooth® module, and vice versa.

### 8.2 Typical Application

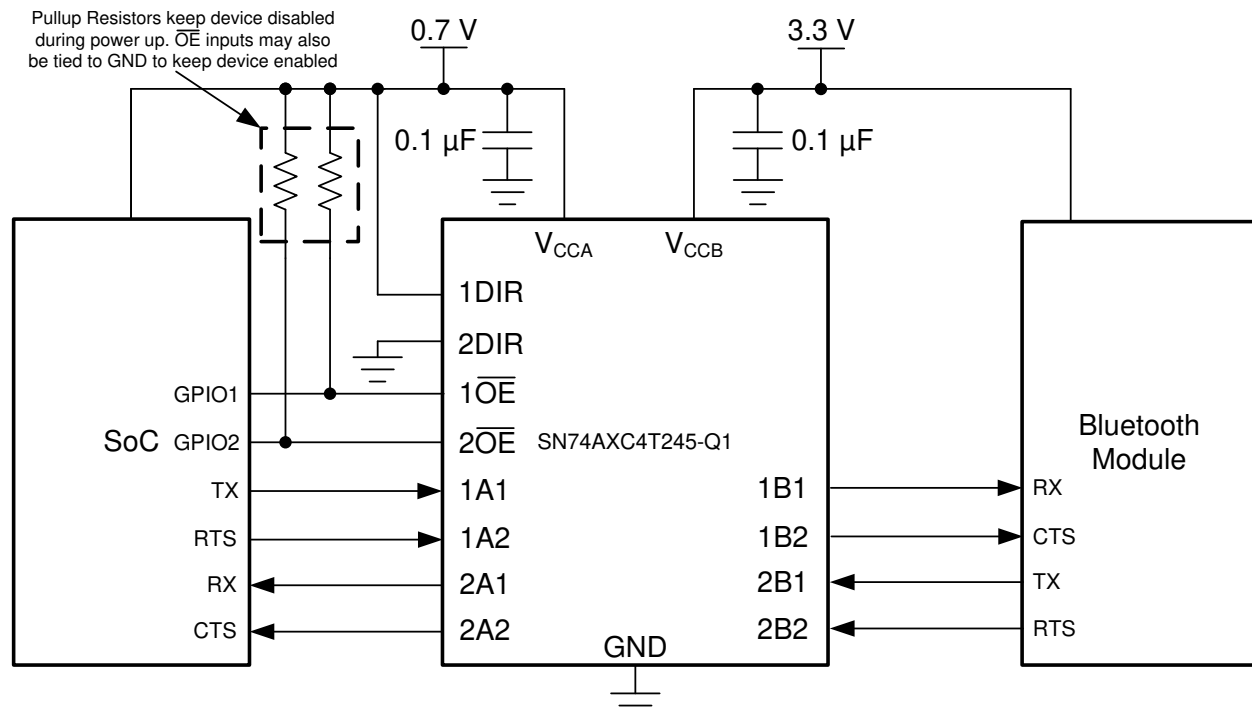

Figure 8-1. UART Interface Application

#### 8.2.1 Design Requirements

For this design example, use the parameters listed in Table 8-1.

Table 8-1. Design Parameters

DESIGN PARAMETERS	EXAMPLE VALUES
Input voltage range	0.65V to 3.6V
Output voltage range	0.65V to 3.6V

## 8.2.2 Detailed Design Procedure

To begin the design process, determine the following:

- Input voltage range:
  - Use the supply voltage of the device that is driving the SN74AXC4T245-Q1 device to determine the input voltage range. For a valid logic-high, the value must exceed the high-level input voltage ( $V_{IH}$ ) of the input port. For a valid logic low the value must be less than the low-level input voltage ( $V_{IL}$ ) of the input port.
- Output voltage range:
  - Use the supply voltage of the device that the SN74AXC4T245-Q1 device is driving to determine the output voltage range.

## 8.2.3 Application Curve

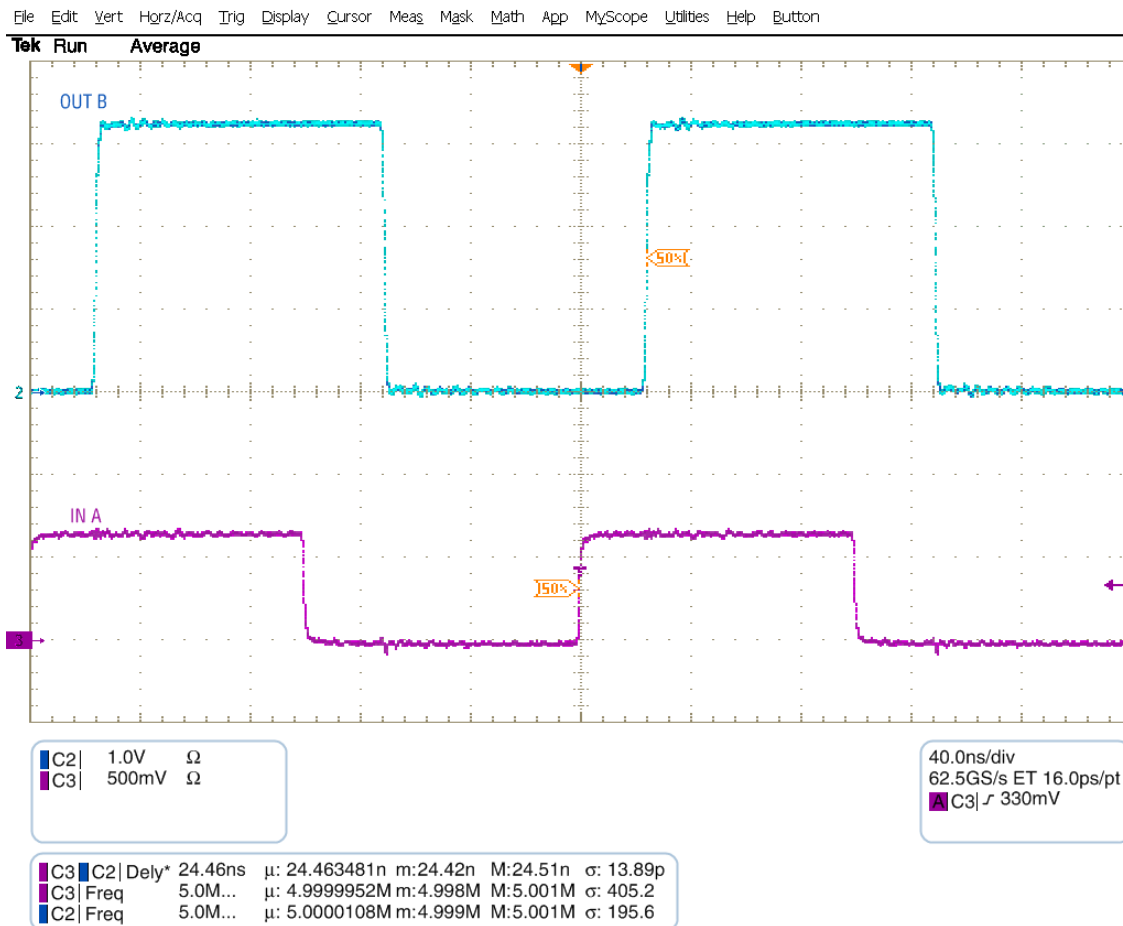

Figure 8-2. Up Translation at 2.5MHz (0.7V to 3.3V)

## 8.3 Power Supply Recommendations

Always apply a ground reference to the GND pins first. This device is designed for glitch free power sequencing without any supply sequencing requirements such as ramp order or ramp rate.

This device was designed with various power supply sequencing methods in mind to help prevent unintended triggering of downstream devices. For more information regarding the power up glitch performance of the AXC family of level translators, see [Glitch Free Power Sequencing With AXC Level Translators](#).

## 8.4 Layout

### 8.4.1 Layout Guidelines

For device reliability, following common printed-circuit board layout guidelines are recommended:

- Use bypass capacitors on the power supply pins and place them as close to the device as possible.
- Use short trace lengths to avoid excessive loading.

### 8.4.2 Layout Example

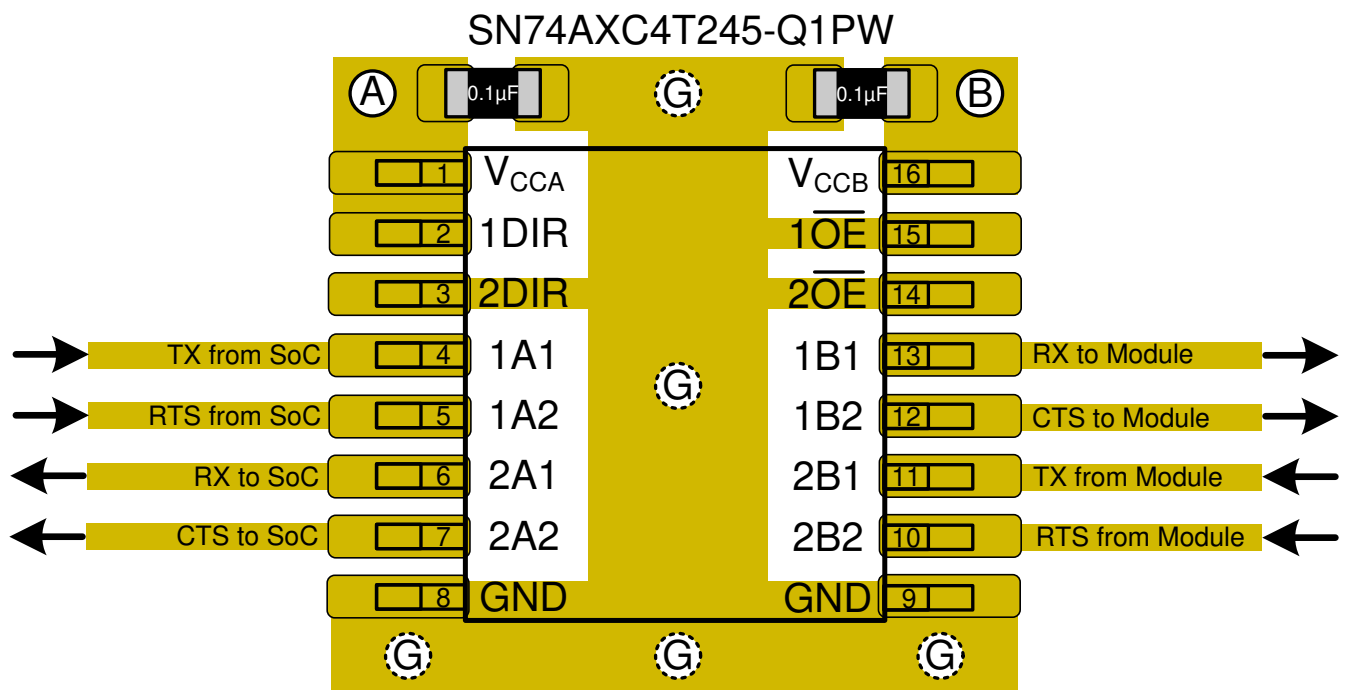
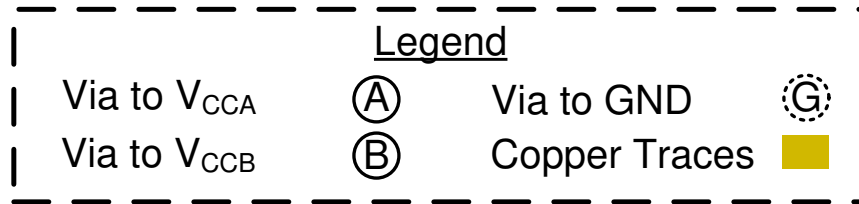

Figure 8-3. Layout Example

## 9 Device and Documentation Support

### 9.1 Documentation Support

#### 9.1.1 Related Documentation

For related documentation see the following:

- Texas Instruments, [Glitch Free Power Sequencing With AXC Level Translators application report](#)
- Texas Instruments, [Implications of Slow or Floating CMOS Inputs application report](#)
- Texas Instruments, [Low Voltage Translation For Standard Interfaces application report](#)
- Texas Instruments, [Power Sequencing for AXC Family of Devices application report](#)
- Texas Instruments, [SN74AXC4T245RSV EVM evaluation module user's guide](#)
- Texas Instruments, [UART Interface Using SN74AXC4T245 video](#)

### 9.2 Receiving Notification of Documentation Updates

To receive notification of documentation updates, navigate to the device product folder on [ti.com](http://ti.com). Click on *Notifications* to register and receive a weekly digest of any product information that has changed. For change details, review the revision history included in any revised document.

### 9.3 Support Resources

[TI E2E™ support forums](#) are an engineer's go-to source for fast, verified answers and design help — straight from the experts. Search existing answers or ask your own question to get the quick design help you need.

Linked content is provided "AS IS" by the respective contributors. They do not constitute TI specifications and do not necessarily reflect TI's views; see TI's [Terms of Use](#).

### 9.4 Trademarks

TI E2E™ is a trademark of Texas Instruments.

Bluetooth® is a registered trademark of Bluetooth Special Interest Group (SIG).

All trademarks are the property of their respective owners.

### 9.5 Electrostatic Discharge Caution



This integrated circuit can be damaged by ESD. Texas Instruments recommends that all integrated circuits be handled with appropriate precautions. Failure to observe proper handling and installation procedures can cause damage.

ESD damage can range from subtle performance degradation to complete device failure. Precision integrated circuits may be more susceptible to damage because very small parametric changes could cause the device not to meet its published specifications.

### 9.6 Glossary

[TI Glossary](#) This glossary lists and explains terms, acronyms, and definitions.

## 10 Revision History

NOTE: Page numbers for previous revisions may differ from page numbers in the current version.

Changes from Revision E (December 2021) to Revision F (January 2024)	Page
• Added the <i>I/Os with Integrated Static Pull-Down Resistors</i> section.....	20

Changes from Revision D (September 2021) to Revision E (December 2021)	Page
• Changed the status of the <i>WBQB</i> package from: <i>Product Preview</i> to: <i>Production</i> .....	1

---

<b>Changes from Revision C (March 2021) to Revision D (September 2021)</b>	<b>Page</b>
• Added BQB (WQFN) package for APL.....	1

---

<b>Changes from Revision B (July 2020) to Revision C (March 2021)</b>	<b>Page</b>
• Changed the status of the BQB (WQFN) package option from <i>preview</i> to <i>production</i> .....	1

---

<b>Changes from Revision A (December 2019) to Revision B (July 2020)</b>	<b>Page</b>
• Updated the numbering format for tables, figures and cross-references throughout the document.....	1
• Added BQB (WQFN) package option to <i>Device Information</i> table .....	1

---

<b>Changes from Revision * (July 2019) to Revision A (December 2019)</b>	<b>Page</b>
• Changed from Advance Information to Production Data .....	1

---

## **11 Mechanical, Packaging, and Orderable Information**

The following pages include mechanical, packaging, and orderable information. This information is the most current data available for the designated devices. This data is subject to change without notice and revision of this document. For browser-based versions of this data sheet, refer to the left-hand navigation.

**PACKAGING INFORMATION**

Orderable Device	Status (1)	Package Type	Package Drawing	Pins	Package Qty	Eco Plan (2)	Lead finish/ Ball material (6)	MSL Peak Temp (3)	Op Temp (°C)	Device Marking (4/5)	Samples
CAXC4T245QBQBRQ1	ACTIVE	WQFN	BQB	16	3000	RoHS & Green	NIPDAU	Level-1-260C-UNLIM	-40 to 125	4T245Q	<a href="#">Samples</a>
CAXC4T245QRSVRQ1	ACTIVE	UQFN	RSV	16	3000	RoHS & Green	NIPDAU	Level-1-260C-UNLIM	-40 to 125	1ZDR	<a href="#">Samples</a>
CAXC4T245QWBQBRQ1	ACTIVE	WQFN	BQB	16	3000	RoHS & Green	NIPDAU	Level-1-260C-UNLIM	-40 to 125	4T245Q	<a href="#">Samples</a>
H14T245QRSVRQ1-NT	ACTIVE	UQFN	RSV	16	3000	RoHS & Green	NIPDAU	Level-1-260C-UNLIM	-40 to 125	1ZDR	<a href="#">Samples</a>
SN74AXC4T245QPWRQ1	ACTIVE	TSSOP	PW	16	2000	RoHS & Green	Call TI   NIPDAU	Level-1-260C-UNLIM	-40 to 125	4T245Q	<a href="#">Samples</a>

(1) The marketing status values are defined as follows:

**ACTIVE:** Product device recommended for new designs.

**LIFEBUY:** TI has announced that the device will be discontinued, and a lifetime-buy period is in effect.

**NRND:** Not recommended for new designs. Device is in production to support existing customers, but TI does not recommend using this part in a new design.

**PREVIEW:** Device has been announced but is not in production. Samples may or may not be available.

**OBSELETE:** TI has discontinued the production of the device.

(2) **RoHS:** TI defines "RoHS" to mean semiconductor products that are compliant with the current EU RoHS requirements for all 10 RoHS substances, including the requirement that RoHS substance do not exceed 0.1% by weight in homogeneous materials. Where designed to be soldered at high temperatures, "RoHS" products are suitable for use in specified lead-free processes. TI may reference these types of products as "Pb-Free".

**RoHS Exempt:** TI defines "RoHS Exempt" to mean products that contain lead but are compliant with EU RoHS pursuant to a specific EU RoHS exemption.

**Green:** TI defines "Green" to mean the content of Chlorine (Cl) and Bromine (Br) based flame retardants meet JS709B low halogen requirements of <=1000ppm threshold. Antimony trioxide based flame retardants must also meet the <=1000ppm threshold requirement.

(3) MSL, Peak Temp. - The Moisture Sensitivity Level rating according to the JEDEC industry standard classifications, and peak solder temperature.

(4) There may be additional marking, which relates to the logo, the lot trace code information, or the environmental category on the device.

(5) Multiple Device Markings will be inside parentheses. Only one Device Marking contained in parentheses and separated by a "~" will appear on a device. If a line is indented then it is a continuation of the previous line and the two combined represent the entire Device Marking for that device.

(6) Lead finish/Ball material - Orderable Devices may have multiple material finish options. Finish options are separated by a vertical ruled line. Lead finish/Ball material values may wrap to two lines if the finish value exceeds the maximum column width.

**Important Information and Disclaimer:**The information provided on this page represents TI's knowledge and belief as of the date that it is provided. TI bases its knowledge and belief on information provided by third parties, and makes no representation or warranty as to the accuracy of such information. Efforts are underway to better integrate information from third parties. TI has taken and continues to take reasonable steps to provide representative and accurate information but may not have conducted destructive testing or chemical analysis on incoming materials and chemicals. TI and TI suppliers consider certain information to be proprietary, and thus CAS numbers and other limited information may not be available for release.

In no event shall TI's liability arising out of such information exceed the total purchase price of the TI part(s) at issue in this document sold by TI to Customer on an annual basis.

**OTHER QUALIFIED VERSIONS OF SN74AXC4T245-Q1 :**

- Catalog : [SN74AXC4T245](#)

NOTE: Qualified Version Definitions:

- Catalog - TI's standard catalog product

**TAPE AND REEL INFORMATION**

**QUADRANT ASSIGNMENTS FOR PIN 1 ORIENTATION IN TAPE**



\*All dimensions are nominal

Device	Package Type	Package Drawing	Pins	SPQ	Reel Diameter (mm)	Reel Width W1 (mm)	A0 (mm)	B0 (mm)	K0 (mm)	P1 (mm)	W (mm)	Pin1 Quadrant
CAXC4T245QBQRQ1	WQFN	BQB	16	3000	180.0	12.4	2.8	3.8	1.2	4.0	12.0	Q1
CAXC4T245QRSVRQ1	UQFN	RSV	16	3000	178.0	13.5	2.1	2.9	0.75	4.0	12.0	Q1
CAXC4T245QWBQRQ1	WQFN	BQB	16	3000	180.0	12.4	2.8	3.8	1.2	4.0	12.0	Q1
H14T245QRSVRQ1-NT	UQFN	RSV	16	3000	180.0	9.5	2.1	2.9	0.75	4.0	8.0	Q1
SN74AXC4T245QPWRQ1	TSSOP	PW	16	2000	330.0	12.4	6.9	5.6	1.6	8.0	12.0	Q1

**TAPE AND REEL BOX DIMENSIONS**

\*All dimensions are nominal

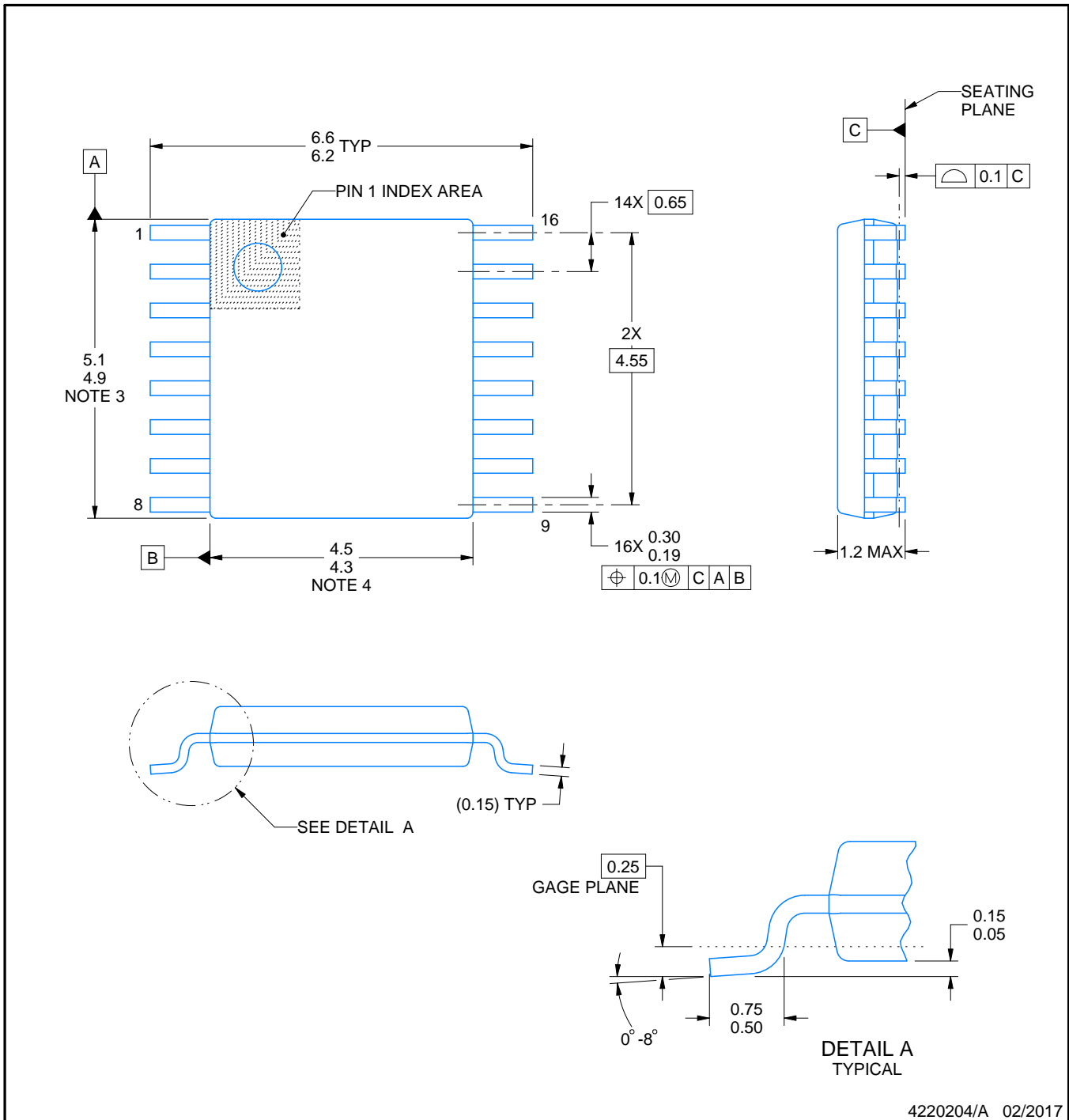
Device	Package Type	Package Drawing	Pins	SPQ	Length (mm)	Width (mm)	Height (mm)
CAXC4T245QBQRQ1	WQFN	BQB	16	3000	210.0	185.0	35.0
CAXC4T245QRSVRQ1	UQFN	RSV	16	3000	189.0	185.0	36.0
CAXC4T245QWBQRQ1	WQFN	BQB	16	3000	210.0	185.0	35.0
H14T245QRSVRQ1-NT	UQFN	RSV	16	3000	189.0	185.0	36.0
SN74AXC4T245QPWRQ1	TSSOP	PW	16	2000	356.0	356.0	35.0



4220204/A 02/2017

NOTES:

1. All linear dimensions are in millimeters. Any dimensions in parenthesis are for reference only. Dimensioning and tolerancing per ASME Y14.5M.
2. This drawing is subject to change without notice.
3. This dimension does not include mold flash, protrusions, or gate burrs. Mold flash, protrusions, or gate burrs shall not exceed 0.15 mm per side.
4. This dimension does not include interlead flash. Interlead flash shall not exceed 0.25 mm per side.
5. Reference JEDEC registration MO-153.

# EXAMPLE BOARD LAYOUT

PW0016A

TSSOP - 1.2 mm max height

SMALL OUTLINE PACKAGE



LAND PATTERN EXAMPLE  
EXPOSED METAL SHOWN  
SCALE: 10X



SOLDER MASK DETAILS

4220204/A 02/2017

NOTES: (continued)

- 6. Publication IPC-7351 may have alternate designs.
- 7. Solder mask tolerances between and around signal pads can vary based on board fabrication site.

# EXAMPLE STENCIL DESIGN

PW0016A

TSSOP - 1.2 mm max height

SMALL OUTLINE PACKAGE



SOLDER PASTE EXAMPLE  
BASED ON 0.125 mm THICK STENCIL  
SCALE: 10X

4220204/A 02/2017

NOTES: (continued)

8. Laser cutting apertures with trapezoidal walls and rounded corners may offer better paste release. IPC-7525 may have alternate design recommendations.
9. Board assembly site may have different recommendations for stencil design.

## GENERIC PACKAGE VIEW

**BQB 16**

**WQFN - 0.8 mm max height**

2.5 x 3.5, 0.5 mm pitch

PLASTIC QUAD FLATPACK - NO LEAD

This image is a representation of the package family, actual package may vary.  
Refer to the product data sheet for package details.

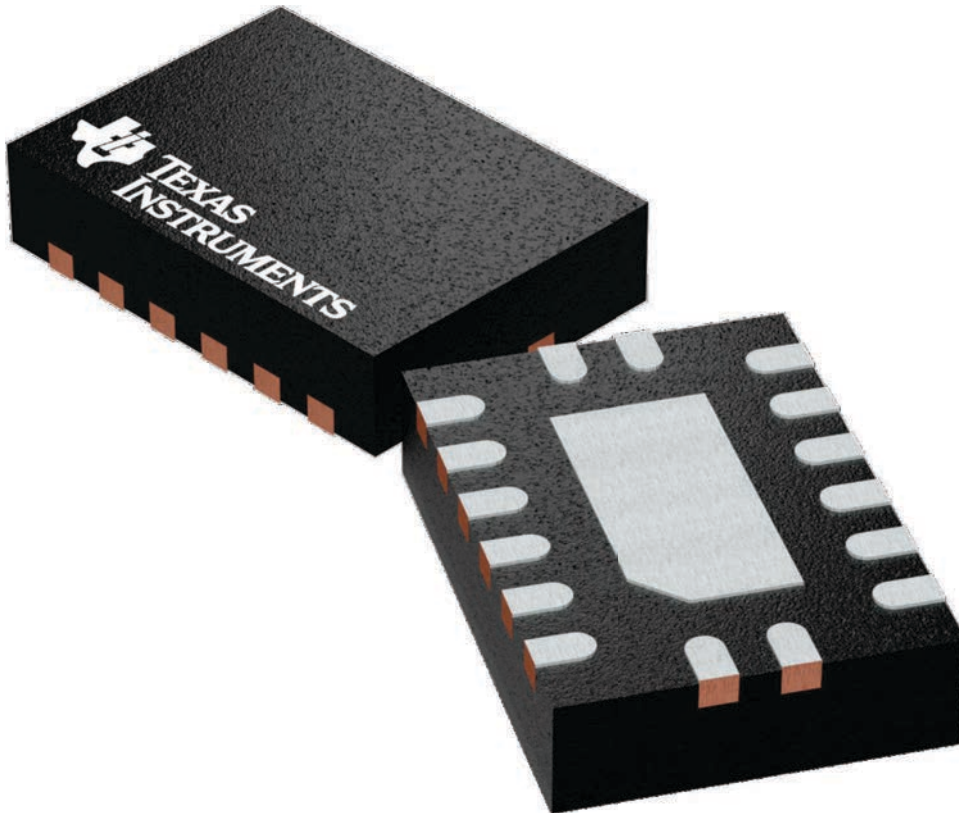

4226161/A

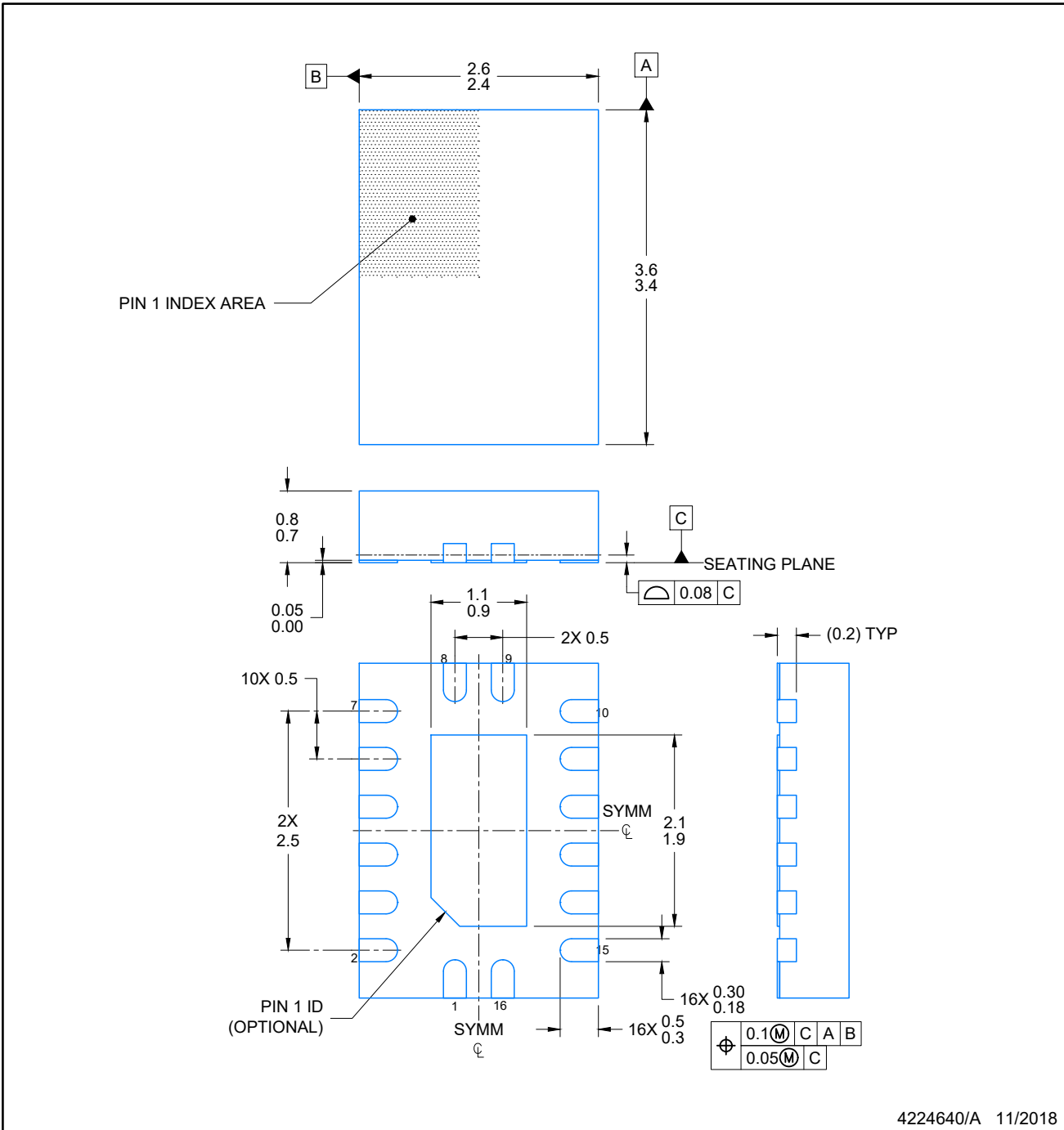

**NOTES:**

1. All linear dimensions are in millimeters. Any dimensions in parenthesis are for reference only. Dimensioning and tolerancing per ASME Y14.5M.
2. This drawing is subject to change without notice.
3. The package thermal pad must be soldered to the printed circuit board for optimal thermal and mechanical performance.



# EXAMPLE STENCIL DESIGN

BQB0016A

WQFN - 0.8 mm max height

PLASTIC QUAD FLAT PACK-NO LEAD

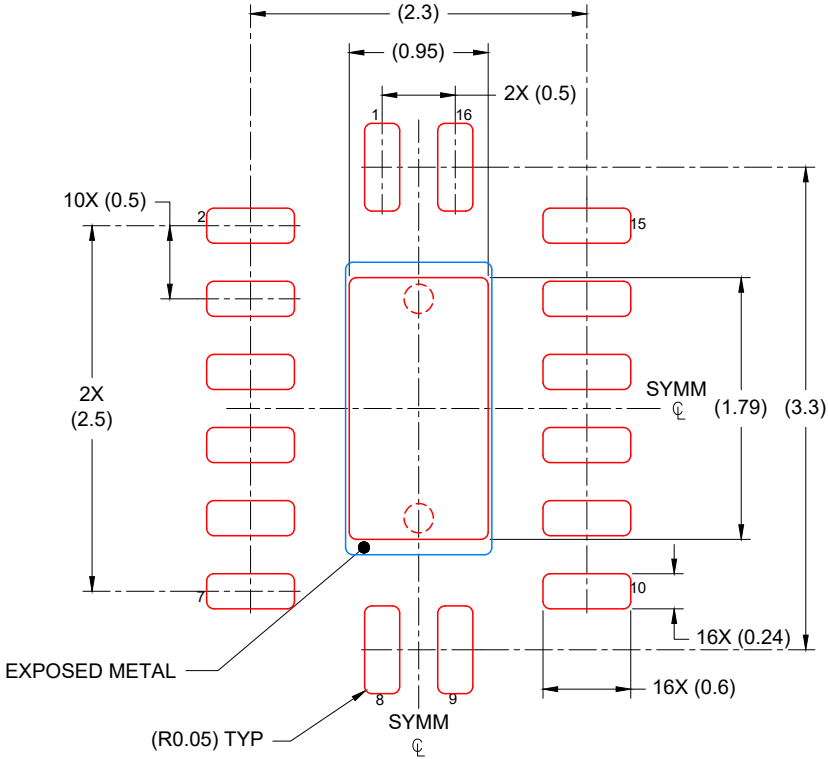

SOLDER PASTE EXAMPLE  
 BASED ON 0.125 mm THICK STENCIL

EXPOSED PAD  
 85% PRINTED COVERAGE BY AREA  
 SCALE: 20X

4224640/A 11/2018

NOTES: (continued)

- 6. Laser cutting apertures with trapezoidal walls and rounded corners may offer better paste release. IPC-7525 may have alternate design recommendations.

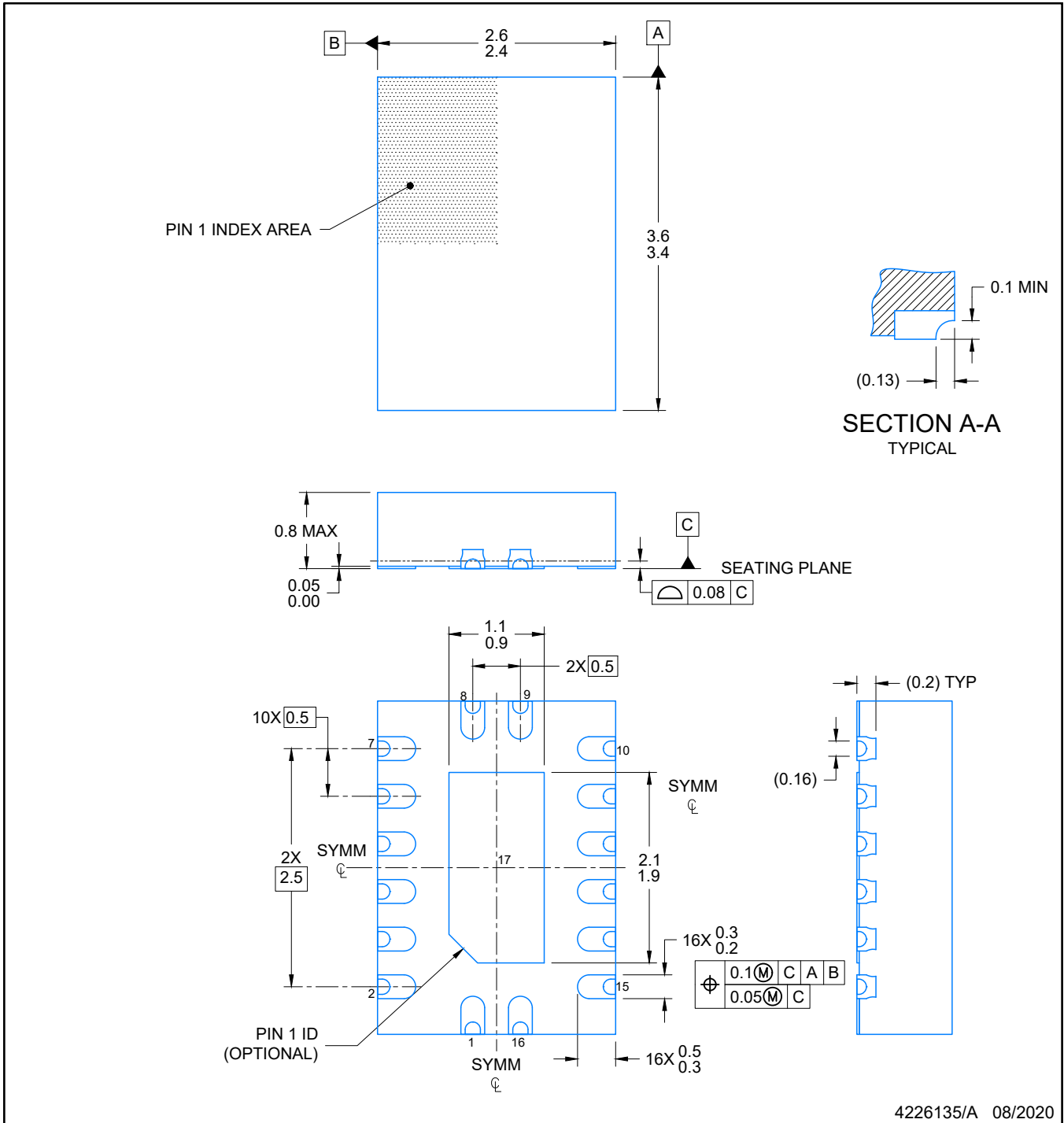

**NOTES:**

1. All linear dimensions are in millimeters. Any dimensions in parenthesis are for reference only. Dimensioning and tolerancing per ASME Y14.5M.
2. This drawing is subject to change without notice.
3. The package thermal pad must be soldered to the printed circuit board for optimal thermal and mechanical performance.



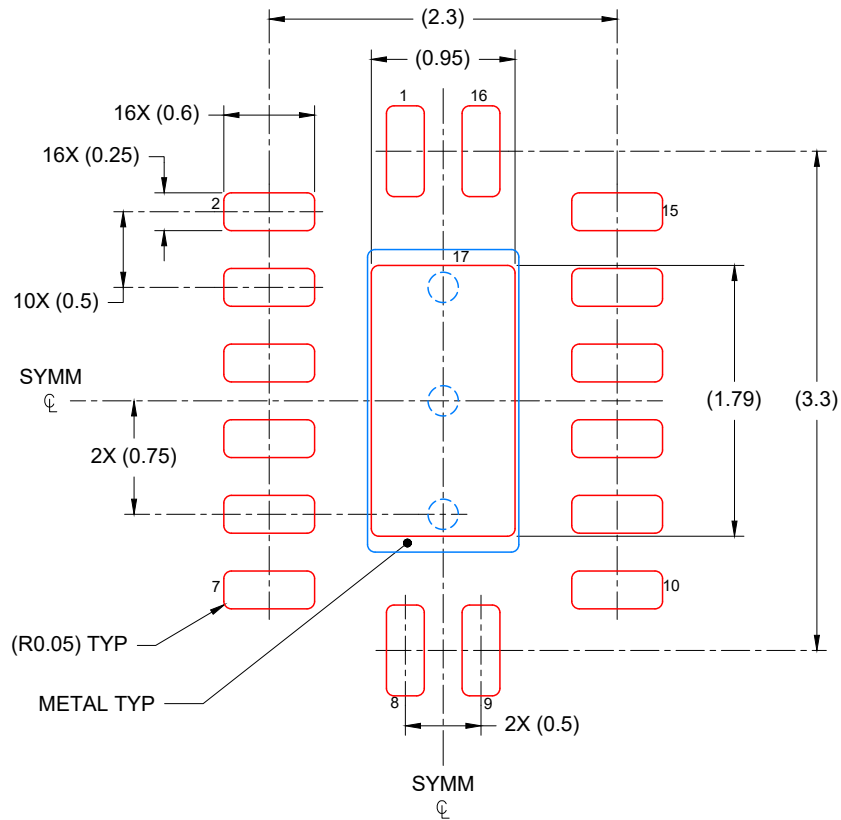

SOLDER PASTE EXAMPLE  
 BASED ON 0.125 mm THICK STENCIL

EXPOSED PAD  
 85% PRINTED COVERAGE BY AREA  
 SCALE: 20X

4226135/A 08/2020

NOTES: (continued)

- 6. Laser cutting apertures with trapezoidal walls and rounded corners may offer better paste release. IPC-7525 may have alternate design recommendations.

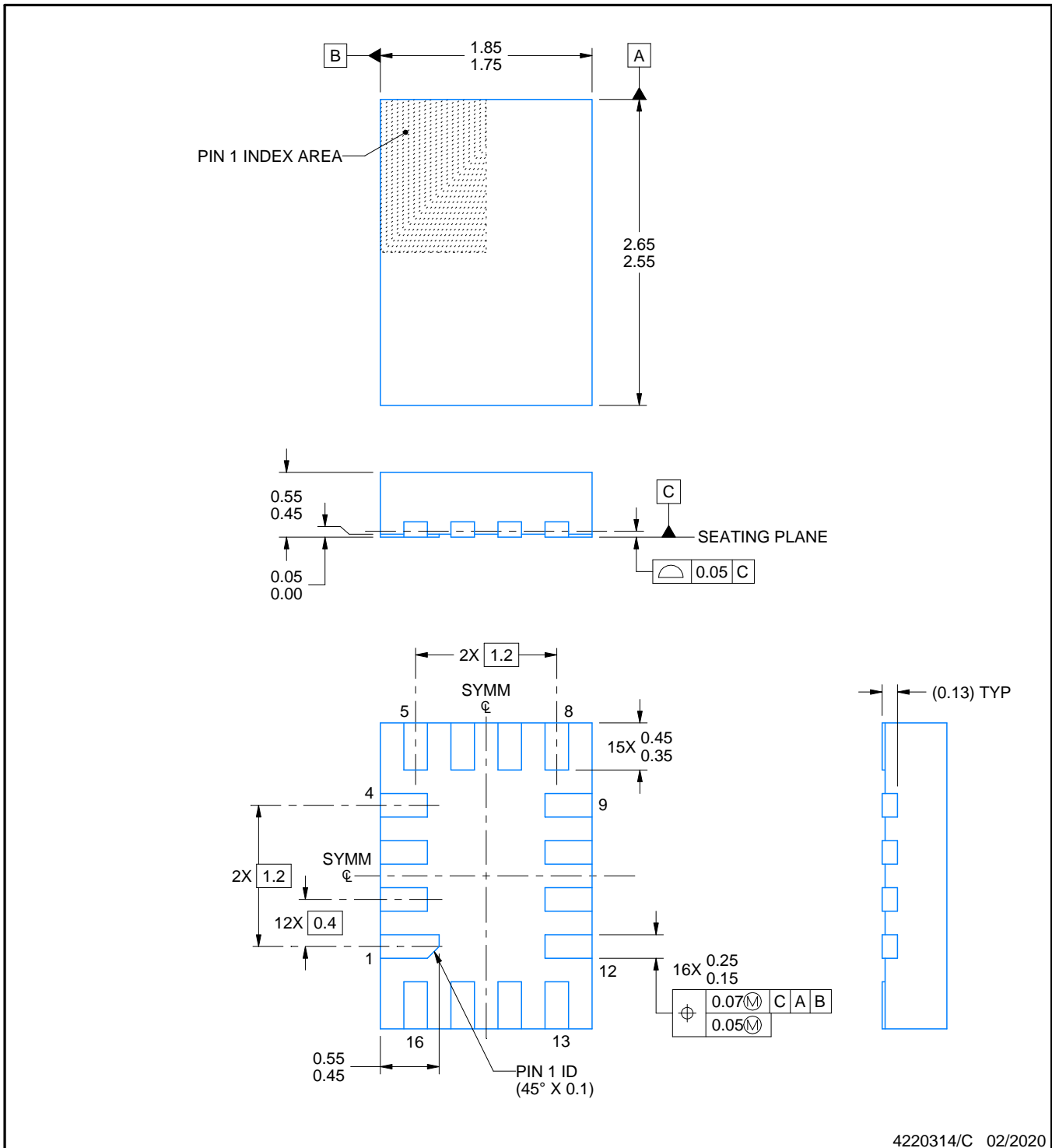
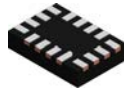

NOTES:

1. All linear dimensions are in millimeters. Any dimensions in parenthesis are for reference only. Dimensioning and tolerancing per ASME Y14.5M.
2. This drawing is subject to change without notice.

# EXAMPLE BOARD LAYOUT

RSV0016A

UQFN - 0.55 mm max height

ULTRA THIN QUAD FLATPACK - NO LEAD

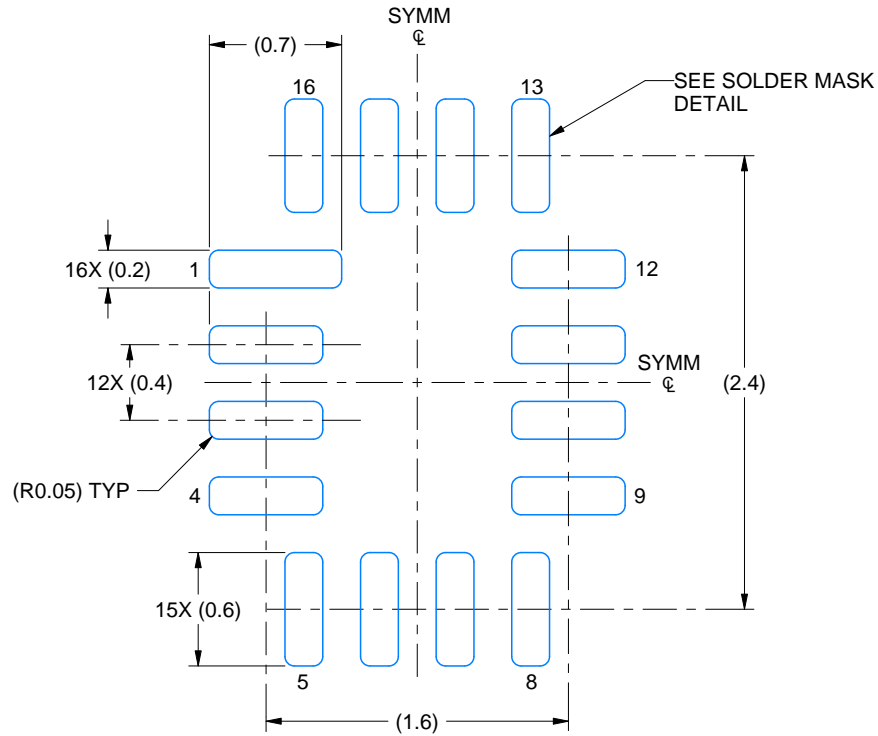

LAND PATTERN EXAMPLE  
EXPOSED METAL SHOWN  
SCALE: 25X

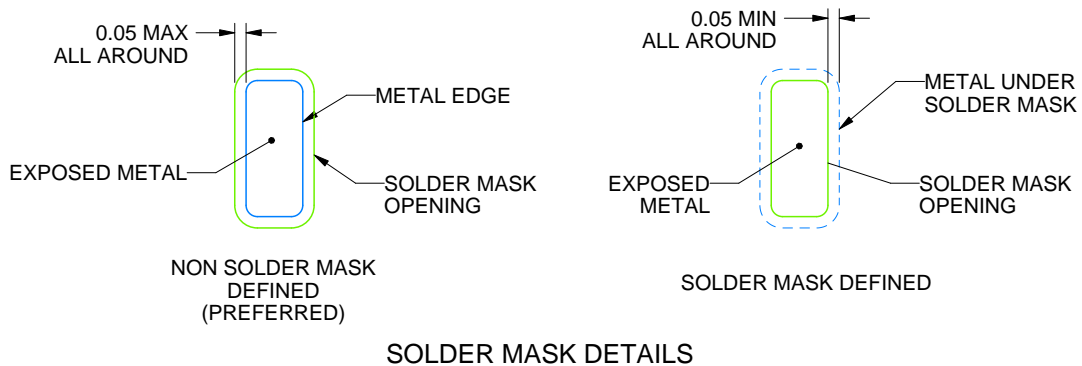

4220314/C 02/2020

NOTES: (continued)

3. For more information, see Texas Instruments literature number SLUA271 ([www.ti.com/lit/slua271](http://www.ti.com/lit/slua271)).

# EXAMPLE STENCIL DESIGN

RSV0016A

UQFN - 0.55 mm max height

ULTRA THIN QUAD FLATPACK - NO LEAD

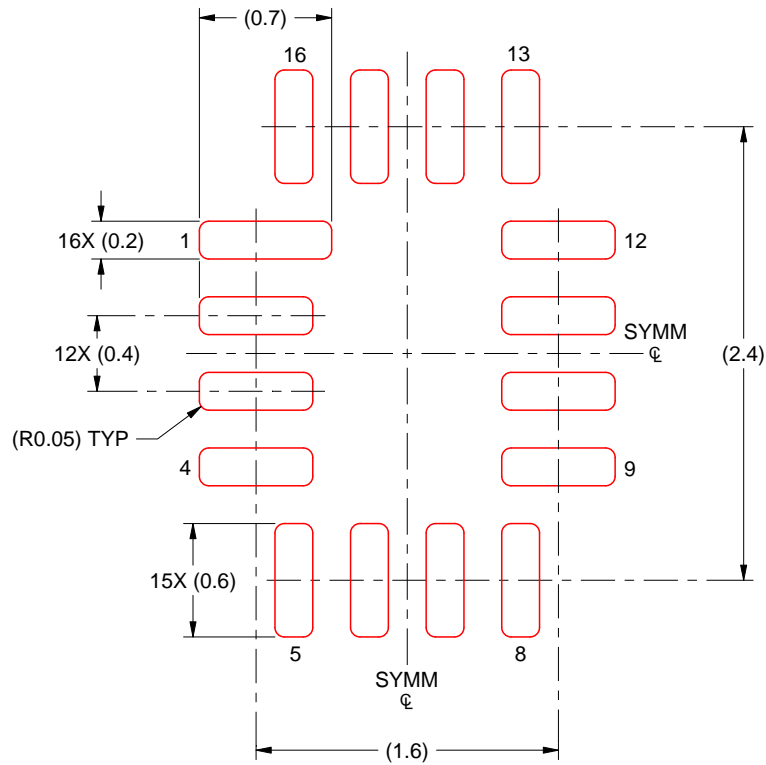

SOLDER PASTE EXAMPLE  
BASED ON 0.125 MM THICK STENCIL  
SCALE: 25X

4220314/C 02/2020

NOTES: (continued)

4. Laser cutting apertures with trapezoidal walls and rounded corners may offer better paste release. IPC-7525 may have alternate design recommendations.

## IMPORTANT NOTICE AND DISCLAIMER

TI PROVIDES TECHNICAL AND RELIABILITY DATA (INCLUDING DATA SHEETS), DESIGN RESOURCES (INCLUDING REFERENCE DESIGNS), APPLICATION OR OTHER DESIGN ADVICE, WEB TOOLS, SAFETY INFORMATION, AND OTHER RESOURCES "AS IS" AND WITH ALL FAULTS, AND DISCLAIMS ALL WARRANTIES, EXPRESS AND IMPLIED, INCLUDING WITHOUT LIMITATION ANY IMPLIED WARRANTIES OF MERCHANTABILITY, FITNESS FOR A PARTICULAR PURPOSE OR NON-INFRINGEMENT OF THIRD PARTY INTELLECTUAL PROPERTY RIGHTS.

These resources are intended for skilled developers designing with TI products. You are solely responsible for (1) selecting the appropriate TI products for your application, (2) designing, validating and testing your application, and (3) ensuring your application meets applicable standards, and any other safety, security, regulatory or other requirements.

These resources are subject to change without notice. TI grants you permission to use these resources only for development of an application that uses the TI products described in the resource. Other reproduction and display of these resources is prohibited. No license is granted to any other TI intellectual property right or to any third party intellectual property right. TI disclaims responsibility for, and you will fully indemnify TI and its representatives against, any claims, damages, costs, losses, and liabilities arising out of your use of these resources.

TI's products are provided subject to [TI's Terms of Sale](#) or other applicable terms available either on [ti.com](https://www.ti.com) or provided in conjunction with such TI products. TI's provision of these resources does not expand or otherwise alter TI's applicable warranties or warranty disclaimers for TI products.

TI objects to and rejects any additional or different terms you may have proposed.

Mailing Address: Texas Instruments, Post Office Box 655303, Dallas, Texas 75265  
Copyright © 2024, Texas Instruments Incorporated

## Looking for pricing, stock, or lifecycle information?

Click below to explore more details on WIN SOURCE:

 [View CAXC4T245QBQBRQ1 on WIN SOURCE](#)

 [Texas Instruments](#) Information

## Optimize Your Supply Chain with WIN SOURCE Solutions

-  Global Sourcing Solution
-  Obsolete Management
-  Cost Control Management
-  Shortage Management
-  Alternative Solution
-  Excess Inventory Management