



**THE DATASHEET OF  
BD81A74EFV-ME2**



# 4ch White LED Driver Built-in Current Driver Buck-Boost and Boost DC/DC Converter for Automotive

**BD81A74EFV-M BD81A74MUV-M**

## General Description

BD81A74EFV-M / BD81A74MUV-M is a white LED driver with the capability of withstanding high input voltage (maximum 35 V). This driver has 4ch constant-current drivers in 1-chip, where each channel can draw up to 120 mA (Max), and it is suitable for high illumination LED drive. Furthermore, a buck-boost current mode DC/DC converter is also built to achieve stable operation during power voltage fluctuation. Light modulation (10,000:1@100 Hz dimming function) is possible by PWM input.

## Features

- AEC-Q100 Qualified\*1
- 4ch Current Driver for LED Drive
- Buck-Boost Current Mode DC/DC Converter
- Control DC/DC Converter Oscillation Frequency by External Synchronized Signal
- Spread Spectrum Function
- LSI Protection Function (UVLO, OVP, TSD, OCP, SCP)
- LED Abnormality Detection Function (Open/Short)
- VOUT Discharge Function (Buck-Boost Structure Limitation)

\*1 Grade 1

## Applications

- Automotive CID (Center Information Display) Panel
- Car Navigation
- Cluster Panel
- HUD (Head Up Display)
- Small and Medium Type LCD Panels for Automotive Use

## Key Specifications

- Operating Input Voltage Range 4.5 V to 35 V
- Output LED Current Accuracy  $\pm 3.0\%$ @50 mA
- DC/DC Oscillation Frequency 200 kHz to 2200 kHz
- Operating Temperature  $-40\text{ }^{\circ}\text{C}$  to  $+125\text{ }^{\circ}\text{C}$
- LED Maximum Output Current 120 mA/ch
- LED Maximum Dimming Ratio 10,000:1@100 Hz
- PWM Minimum Pulse Width 1.0  $\mu\text{s}$

## Packages

VQFN28SV5050  
HTSSOP-B28

## W (Typ) x D (Typ) x H (Max)

5.0 mm x 5.0 mm x 1.0 mm  
9.7 mm x 6.4 mm x 1.0 mm

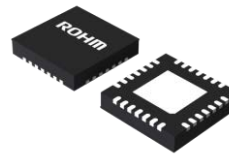

VQFN28SV5050  
BD81A74MUV-M

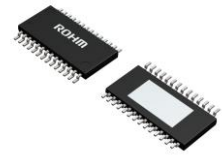

HTSSOP-B28  
BD81A74EFV-M

## Typical Application Circuit

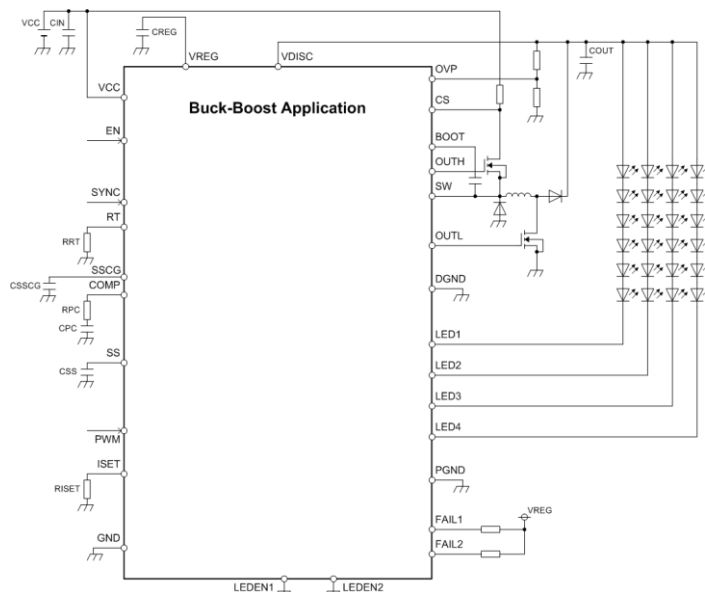

○Product structure : Silicon integrated circuit ○This product has no designed protection against radioactive rays  
○This product is protected by U.S. Patent No.7,235,954, No.7,541,785, No.7,944,189.

## Pin Configuration

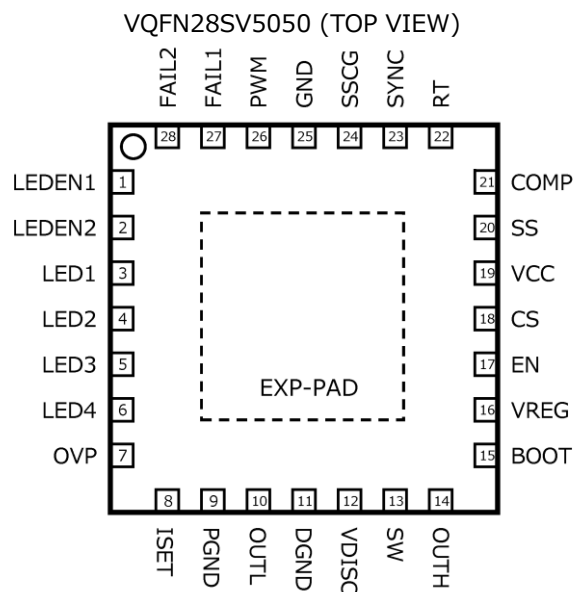

## Pin Description

Pin No.	Pin Name	Function
1	LEDEN1	Enable pin 1 for LED output
2	LEDEN2	Enable pin 2 for LED output
3	LED1	LED output pin 1
4	LED2	LED output pin 2
5	LED3	LED output pin 3
6	LED4	LED output pin 4
7	OVP	Over voltage detection pin
8	ISET	LED output current setting pin
9	PGND	LED output GND pin
10	OUTL	Low side FET gate pin
11	DGND	DC/DC converter output GND pin
12	VDISC	Output voltage discharge pin
13	SW	High side FET source pin
14	OUTH	High side FET gate pin
15	BOOT	High side FET driver power supply pin
16	VREG	Internal constant voltage
17	EN	Enable pin
18	CS	DC/DC converter current sense pin
19	VCC	Input power supply pin
20	SS	"Soft Start" capacitor connection
21	COMP	Error Amp output
22	RT	Oscillation frequency setting resistor connect
23	SYNC	External synchronization input pin
24	SSCG	Spread spectrum setting capacitor pin
25	GND	Small signal GND pin
26	PWM	PWM light modulation signal input pin
27	FAIL1	"Failure" signal output pin 1
28	FAIL2	"Failure" signal output pin 2
-	EXP-PAD	Back side thermal PAD (Connect to GND)

## Pin Configuration

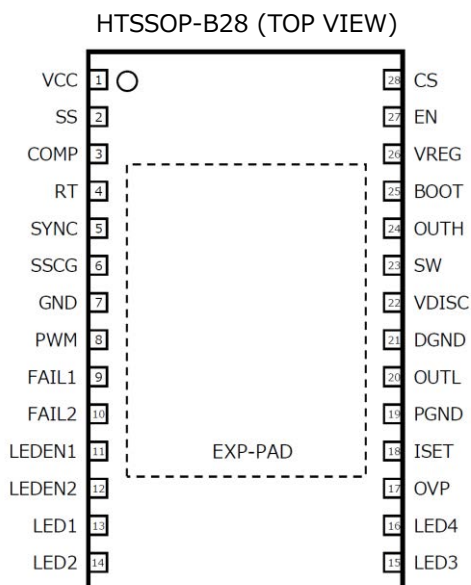

## Pin Description

Pin No.	Pin Name	Function
1	VCC	Input power supply pin
2	SS	"Soft Start" capacitor connection
3	COMP	Error Amp output
4	RT	Oscillation frequency setting resistor connect
5	SYNC	External synchronization input pin
6	SSCG	Spread spectrum setting capacitor pin
7	GND	Small signal GND pin
8	PWM	PWM light modulation signal input pin
9	FAIL1	"Failure" signal output pin 1
10	FAIL2	"Failure" signal output pin 2
11	LEDEN1	Enable pin 1 for LED output
12	LEDEN2	Enable pin 2 for LED output
13	LED1	LED output pin 1
14	LED2	LED output pin 2
15	LED3	LED output pin 3
16	LED4	LED output pin 4
17	OVP	Over voltage detection pin
18	ISET	LED output current setting pin
19	PGND	LED output GND pin
20	OUTL	Low side FET gate pin
21	DGND	DC/DC converter output GND pin
22	VDISC	Output voltage discharge pin
23	SW	High side FET source pin
24	OUTH	High side FET gate pin
25	BOOT	High side FET driver power supply pin
26	VREG	Internal constant voltage
27	EN	Enable pin
28	CS	DC/DC converter current sense pin
-	EXP-PAD	Back side thermal PAD (Connect to GND)

Block Diagram

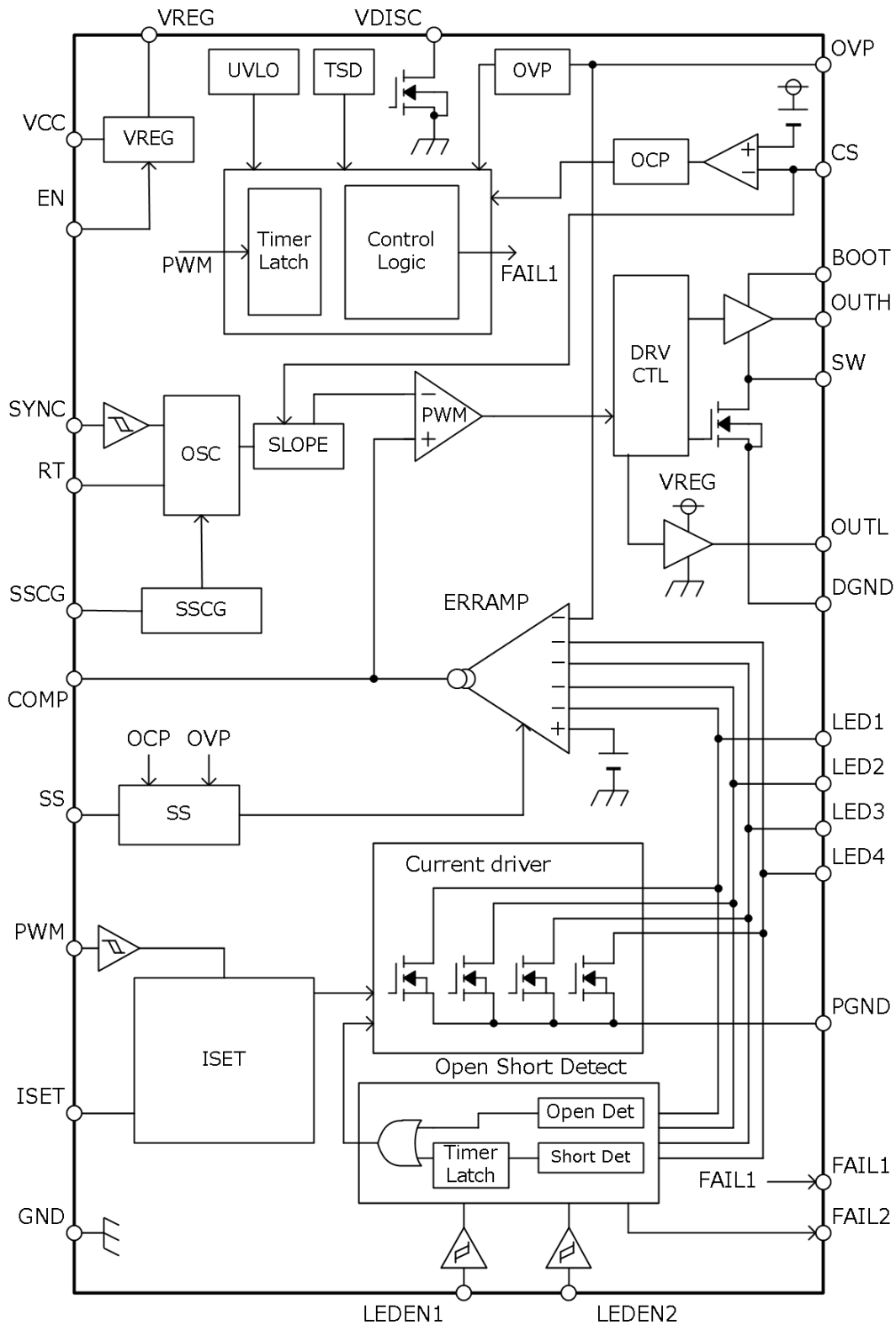

**Description of Blocks**

If there is no description, the mentioned values are typical value.

1. Reference Voltage (VREG)

VREG Block generates 5 V at EN = High, and outputs to the VREG pin. This voltage ( $V_{VREG}$ ) is used as power supply for internal circuit. It is also used to fix each input pin to High voltage outside IC. It cannot supply power to other parts than this IC. The VREG pin has UVLO function, and it starts operation at  $V_{CC} \geq 4.0$  V and  $V_{VREG} \geq 3.5$  V and stops when at  $V_{CC} \leq 3.5$  V or  $V_{VREG} \leq 2.0$  V. About the condition to release/detect VREG voltage, refer to [Table 2](#) on section 4.4. Protection Feature. Connect a ceramic capacitor ( $C_{VREG}$ ) to the VREG pin for phase margin.  $C_{VREG}$  range is 1.0  $\mu$ F to 4.7  $\mu$ F and recommended value is 2.2  $\mu$ F. If the  $C_{VREG}$  is not connected, it might occur unstable operation e.g. oscillation.

2. Current Driver

Table 1. LED Control Logic

LEDEN1	LEDEN2	LED1	LED2	LED3	LED4
Low	Low	ON	ON	ON	ON
High	Low	ON	ON	ON	OFF
Low	High	ON	ON	OFF	OFF
High	High	ON	OFF	OFF	OFF

If there is the constant-current driver output not to use, make the LED1 to LED4 pins ‘open’ and turn off the channel, which is not used, with the LEDEN1 and LEDEN2 pins. The truth table for these pins is shown above. If the unused constant-current driver output is set open without the process of the LEDEN1 and LEDEN2 pins, the ‘open detection’ is activated. The LEDEN1 and LEDEN2 pins are pulled down internally in the IC and it is low at ‘open’ condition. They can be connected to the VREG pin and fixed to logic High. Logic of the LEDEN1 and LEDEN2 pins are not switchable during these in operation.

(1) Output Current Setting ( $R_{ISET}$ )

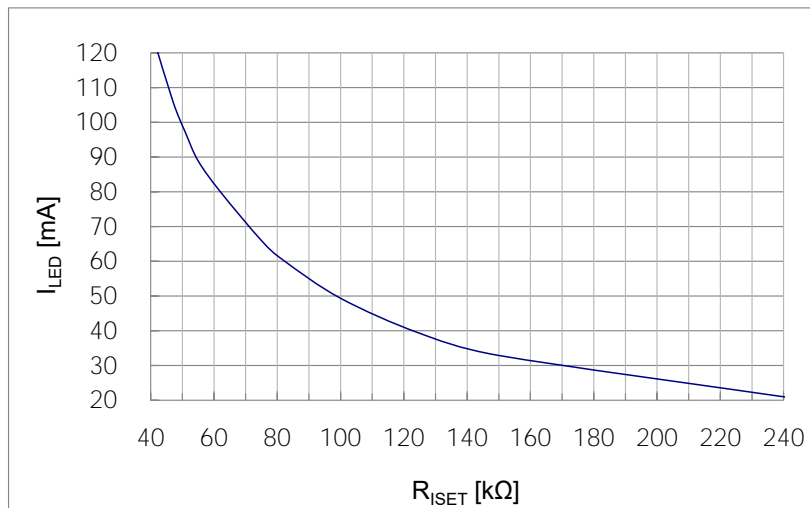

Figure 1.  $I_{LED}$  vs  $R_{ISET}$

The Output Current  $I_{LED}$  can be obtained by the following equation:

$$I_{LED} = 5000/R_{ISET} \quad [A]$$

The operating range of the  $R_{ISET}$  value is from 41 k $\Omega$  to 250 k $\Omega$ . Additionally, the  $R_{ISET}$  value could not be changed during operation. In this IC, ISET-GND short protection is built-in to protect an LED element from excess current when the ISET pin and GND are shorted. If the  $R_{ISET}$  value is 4.7 k $\Omega$  or less, the IC detects ISET-GND short condition and LED current is turned off.

2. Current Driver – continued

<Caution of Large LED Current Setting>

During PWM dimming, the LED pin voltage ( $V_{LED}$ ) rises when PWM = Low because LED current doesn't flow, and controls  $V_{LED}$  to 1 V when PWM = High. When PWM rise up,  $V_{LED}$  undershoot may occur depends on LED current setting or external parts including the output capacitor. The undershoot is large especially at high temperature and large LED current.

LED current may decrease instantly as Figure 2(a) shows by the undershoot. The undershoot and the settable LED current are shown in Figure 2(b).

If the LED current is decreased with the undershoot, it may not see as the LED flicker. Evaluate with the actual application certainly, and check at the visual perspective.

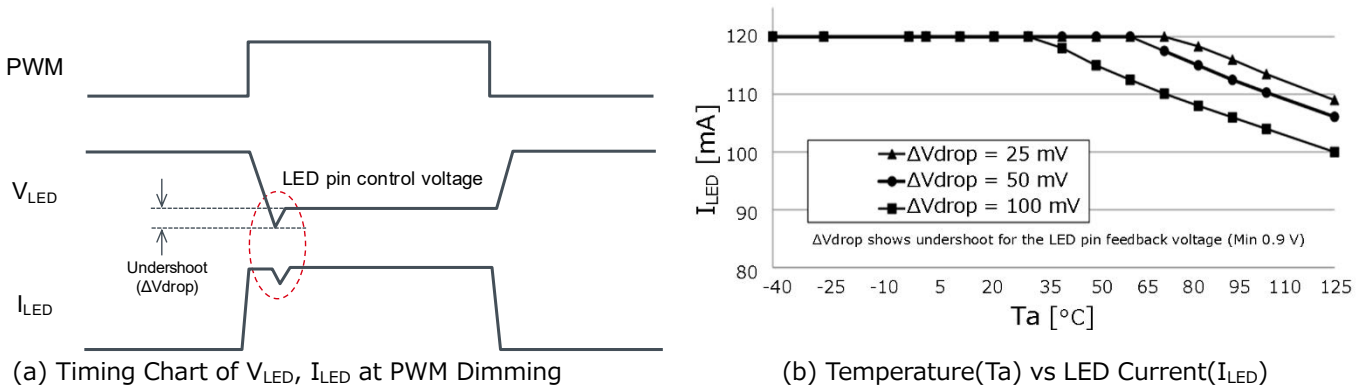

Figure 2. Relation Between Undershoot of  $V_{LED}$  and LED Current

(2) PWM Dimming Control

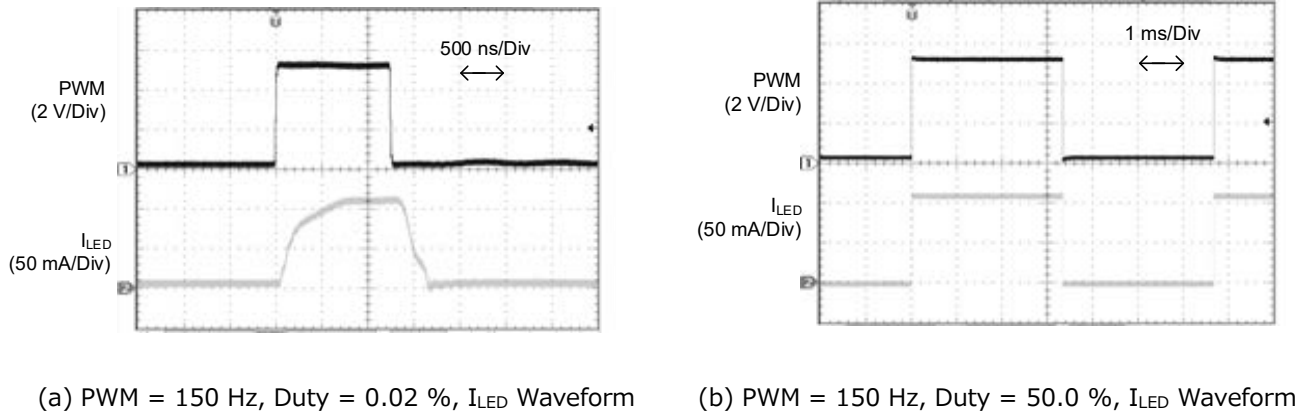

Figure 3. PWM Dimming Waveform

The current driver ON/OFF is controlled by the PWM pin. The duty ratio of the PWM pin becomes duty ratio of  $I_{LED}$ . If PWM dimming is not totally used (i.e. 100 %), fix the PWM pin to High. Output light intensity is the highest at 100 %.

**Description of Blocks – continued**

3. Buck-Boost DC/DC Converter

(1) Number of LED in Series Connection

This IC controls output voltage to become 1.0 V by detecting LED cathode voltage (the LED1 to LED4 pins voltage). When multiple LED outputs are operating, it controls LED pin voltage with the highest LED Vf to become 1.0 V. Thus, the output voltage of other LED pins is higher by the variations of Vf. Set up Vf variation to meet the formula below.

$$LED\ Series\ Number \times Vf\ Variation < Short\ Detection\ Voltage\ (Min) - LED\ Control\ Voltage(Max)$$

(2) Over Voltage Protection (OVP)

The output voltage (VOUT) should be connected to the OVP pin via resistor voltage divider. If the OVP pin voltage is 2.0 V or more, Over Voltage Protection (OVP) is active and stop the DC/DC converter switching. Determine the setting value of OVP function by the total number of the LEDs in the series and the Vf variation. When the OVP pin voltage drops less than 1.94 V after OVP operation, the OVP is released.

$$VOUT \geq \{(R_{OVP1} + R_{OVP2}) / R_{OVP1}\} \times 2.0$$

where:

VOUT is the Output voltage.

R<sub>OVP1</sub> is the GND side OVP resistance.

R<sub>OVP2</sub> is the Output voltage side OVP resistance.

For example, OVP is active when VOUT ≥ 32 V if R<sub>OVP1</sub> = 22 kΩ and R<sub>OVP2</sub> = 330 kΩ.

(3) Buck-Boost DC/DC Converter Oscillation Frequency (f<sub>osc</sub>)

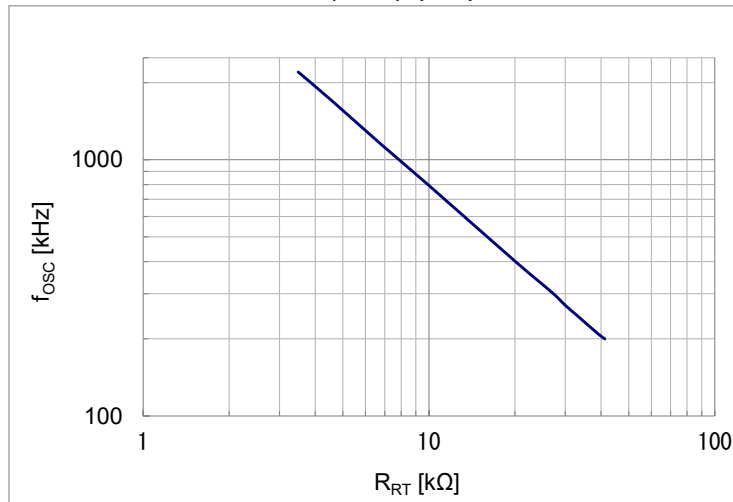

Figure 4. f<sub>osc</sub> vs R<sub>RT</sub>

DC/DC oscillation frequency can be set via a resistor connected to the RT pin. This resistor determines the charge/discharge current to the internal capacitor, thereby changing the oscillation frequency. Set the resistance of R<sub>RT</sub> using the above data and the equation below.

$$f_{osc} = (81 \times 10^5 / R_{RT}) \quad [kHz]$$

81 × 10<sup>5</sup> is the constant value determined in the internal circuit.

Take note that operation could not be guaranteed in the case of settings other than the recommended range.

3. Buck-Boost DC/DC Converter - continued

(4) Spread Spectrum Function

Operation in Spread Spectrum Clock Generation (SSCG) is possible by connecting capacitor to the SSCG pin. The SSCG pin has a comparator and constant current circuit to assume 0.6 V/0.48 V reference voltage, and changes into a triangular waveform. The average of noise can be reduced by changing the switching frequency by a frequency ( $f_{SSCG}$ ) decided in the SSCG pin capacity  $C_{SSCG}$ . The band of the switching frequency becomes 100 % to 80 % of switching frequency when SSCG is not used.

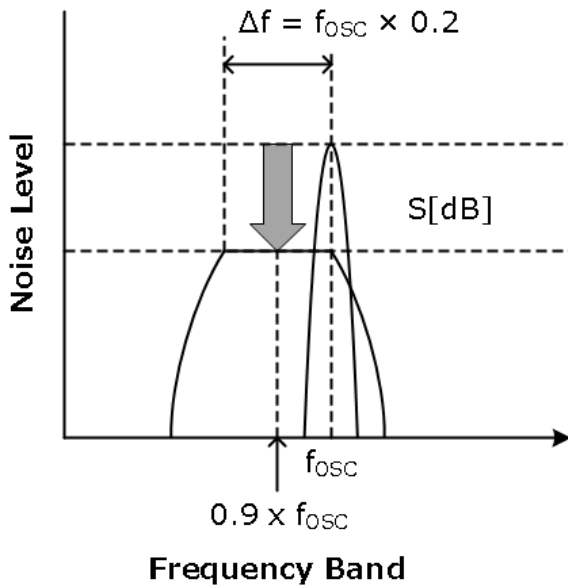

Figure 5. SSCG Noise Reduction Image

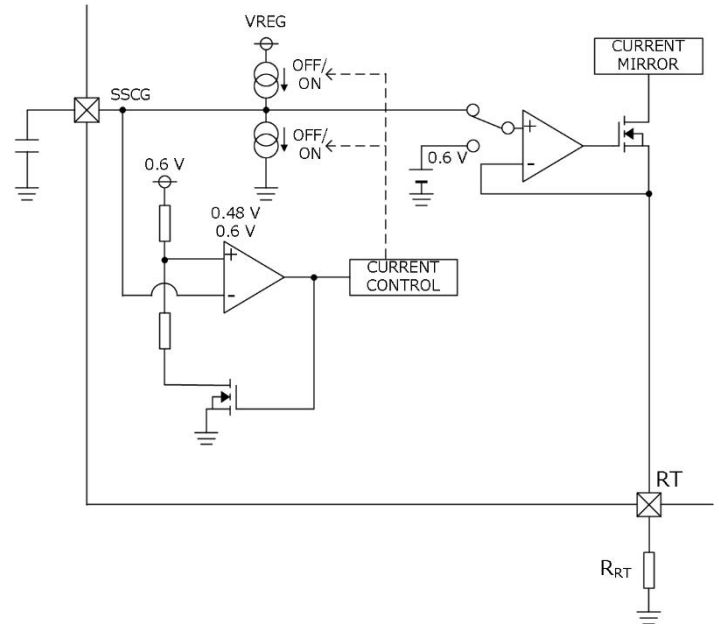

Figure 6. SSCG System Diagram

$f_{SSCG}$  can be calculated by the following equation.

$$f_{SSCG} = \frac{3}{4 \times C_{SSCG} \times R_{RT}} \text{ [Hz]}$$

Set it to satisfy the equation of  $0.4 \text{ kHz} \leq f_{SSCG} \leq 30 \text{ kHz}$ .

Furthermore, quantity of noise reduction  $S$  [dB] in SSCG can be roughly estimated by the equation below.

$$S = -10 \times \log \left( \frac{f_{SSCG}}{f_{OSC} \times 0.2} \right) \text{ [dB]}$$

Short the SSCG pin and the GND pin when SSCG function is not used.

(5) External Synchronization Oscillation Frequency

By clock signal input to the SYNC pin, the internal oscillation frequency can be synchronized externally. Do not switch from external to internal oscillation if the DC/DC switching is active. The clock input to the SYNC pin is valid only in rising edge. Input the external input frequency within  $\pm 20\%$  of internal oscillatory frequency set by the RT pin resistance.

(6) Soft Start Function (SS)

The soft-start (SS) function can start the output voltage slowly while controlling the current during the start by connecting the capacitance ( $C_{SS}$ ) to the SS pin. In this way, output voltage overshoot and inrush current can be prevented. When SS function is not used, set the SS pin open. Refer to [Setting of the Soft Start Time](#) for the calculation of SS time.

3. Buck-Boost DC/DC Converter - continued

(7) Maximum Duty

When DC/DC switching reaches Maximum Duty, expected VOUT voltage could be not output, and LED lights-out might occur by the reduction of LED output current and detection of ground short protection. Set input condition and load condition such that it does not reach Maximum Duty.

(8) DC/DC Switching Control at Over Voltage Output (LSDET)

When the lowest voltage in LED1 to LED4 pins (DC/DC feedback voltage) is more than 1.24 V, LSDET function works and turns off the switching of the DC/DC converter and maintains the COMP voltage (switching Duty). This function reduces the VOUT voltage quickly and intended to output stable switching Duty when VOUT is higher than the aim voltage. For example, LSDET works at the time of the LED4 OPEN detection. The timing chart example is described below.

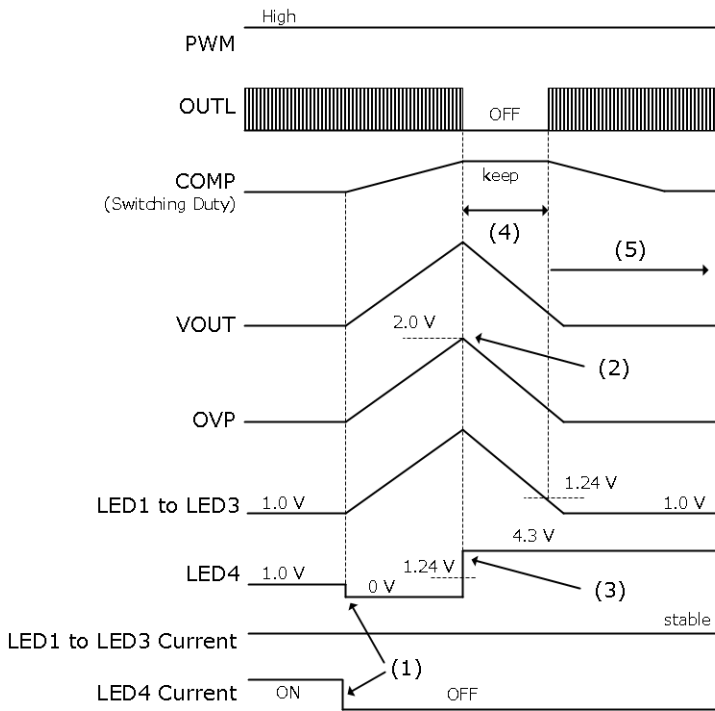

(1) LED4 is OPEN and LED4 current does not flow, LED4 pin voltage is 0 V.

(2) VOUT is increase because of LED4 pin voltage is 0 V. Therefore OVP rises to 2.0 V, and LED4 becomes the OPEN detection state.

(3) LED4 pin voltage pulls up to 4.3 V in the IC by the OPEN detection.

(4) Because LED1 to LED4 pin becomes more than 1.24 V, LSDET function works. DCDC switching is OFF and COMP pin voltage is kept by LSDET function. VOUT is decrease because DC/DC switching is OFF.

(5) LED1 to LED3 pin voltages decrease with a drop of VOUT. And LSDET function is released when any of them is 1.24 V or less. DC/DC switching is turned on again and COMP pin voltage is controlled to appropriate duty.

(9) PWM Pulse and DC/DC Switching

After the fall of the PWM pulse, DC/DC switching is output 12 times and after that, turn off the DC/DC switching during PWM = Low. When PWM becomes High again, the DC/DC switching is on. Because of this, when PWM pulse width is short, it can maintain the output voltage and output the stable LED current.

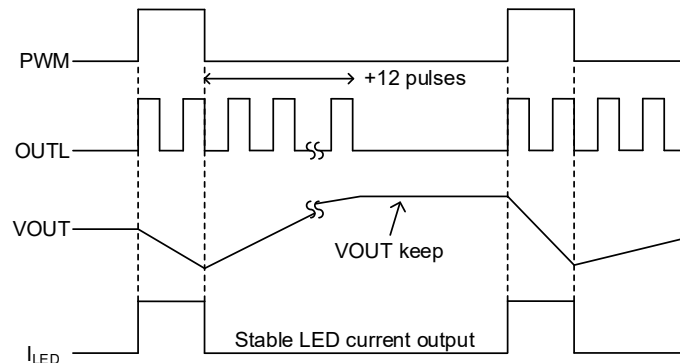

Description of Blocks – continued

4. Protection Feature

Table 2. Detect Condition of Each Protection Feature and Operation during Detection

Function	Detect Condition		Operation During Detection
	[Detection]	[Release/Cancellation]	
UVLO	$V_{CC} \leq 3.5\text{ V}$ or $V_{VREG} \leq 2.0\text{ V}$	$V_{CC} \geq 4.0\text{ V}$ and $V_{VREG} \geq 3.5\text{ V}$	All blocks shut down except VREG
TSD	$T_a \geq 175\text{ }^\circ\text{C}$	$T_a \leq 150\text{ }^\circ\text{C}$	All blocks shut down except VREG
OVP	$V_{OVP} \geq 2.0\text{ V}$	$V_{OVP} \leq 1.94\text{ V}$	DC/DC switching OFF
OCP	$V_{CS} \leq V_{CC}-0.2\text{ V}$	$V_{CS} > V_{CC}-0.2\text{ V}$	DC/DC switching OFF
SCP	$V_{OVP} \leq 0.57\text{ V}$ or Any of $V_{LED1}$ to $V_{LED4}$ is $0.3\text{ V}$ or less (100 ms delay @300 kHz)	EN Reset or UVLO Reset	After SCP delay time, all blocks latch OFF except VREG
LED Open Protection	Any of $V_{LED1}$ to $V_{LED4}$ is $0.3\text{ V}$ or less and $V_{OVP} \geq 2.0\text{ V}$	EN Reset or UVLO Reset	Only detected channel LED current latches OFF
LED Short Protection	Any of $V_{LED1}$ to $V_{LED4}$ is $4.5\text{ V}$ and more (100 ms delay @300 kHz)	EN Reset or UVLO Reset	After LED Short delay time, only detected channel LED current latches OFF

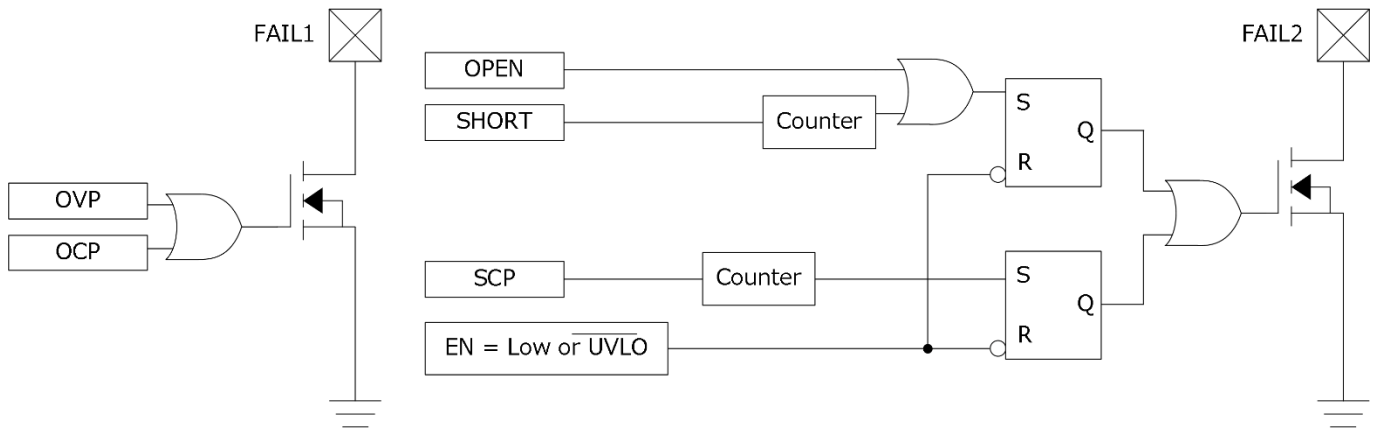

Protection Flag Output Block Diagram

FAIL1 becomes low when OVP or OCP protection is detected, whereas FAIL2 becomes low when SCP, LED open or LED short is detected. If the FAIL1, FAIL2 pin is not used as a flag output, set the FAIL1, FAIL2 pin open or connect it to GND. The output from the FAIL1 and FAIL2 pins are reset and return to High by starting up of EN or release of UVLO. Also, those output is unstable when EN = Low and detecting UVLO. If the FAIL pin is used as a flag output, it is recommended to pull-up the FAIL1, FAIL2 pins to the VREG pin. The recommended value of pull-up resistance is 100 kΩ.

## 4. Protection Feature - continued

## (1) Under-Voltage Lock Out (UVLO)

The UVLO shuts down DC/DC converter and Current Driver when  $V_{CC} \leq 3.5 \text{ V}$  or  $V_{VREG} \leq 2.0 \text{ V}$ . And UVLO is released by  $V_{CC} \geq 4.0 \text{ V}$  and  $V_{VREG} \geq 3.5 \text{ V}$ .

## (2) Thermal Shutdown (TSD)

The TSD shuts down DC/DC converter and Current Driver when the  $T_j$  175 °C or more, and releases when the  $T_j$  becomes 150 °C or less.

## (3) Over Voltage Protection (OVP)

The output voltage of DC/DC converter is detected from the OVP pin voltage, and the over voltage protection is activate if the OVP pin voltage becomes  $\geq 2.0 \text{ V}$ . When OVP is activated, the switching operation of the DC/DC converter turns off. And the OVP pin voltage becomes  $\leq 1.94 \text{ V}$ , OVP is released and the switching operation of the DC/DC converter turns on.

## (4) Over Current Protection (OCP)

The OCP detects the coil current by monitoring the voltage of the high side resistor, and activates when  $V_{CS} \leq V_{CC} - 0.2 \text{ V}$ . When the OCP is activated, the switching operation of the DC/DC converter turns off. And  $V_{CS} > V_{CC} - 0.2 \text{ V}$ , OCP is released and the switching operation of the DC/DC converter turns on.

## (5) Short Circuit Protection (SCP)

The SCP can be operated when the SS pin voltage reaches 3.3 V while start-up. When any of the LED1 to LED4 pins voltage becomes 0.3 V or less or  $V_{OVP} \leq 0.57 \text{ V}$ , the built-in counter operation starts. The clock frequency of counter is the oscillation frequency ( $f_{OSC}$ ), which is determined by  $R_{RT}$ . After it counts 32770, the DC/DC converter and the current driver are latched off. When  $f_{osc} = 300 \text{ kHz}$ , the count time is 100 ms and SCP operates after this count time. If all of the LED pin voltage becomes more than 0.3 V or  $V_{OVP} \geq 1.0 \text{ V}$  before 32770 count, the counter resets and SCP is not detected.

## (6) LED Open Protection

When any of the LED pins voltage is 0.3 V or less and  $V_{OVP} 2.0 \text{ V}$  or more, LED open is detected and latches off the open LED channel only.

## (7) LED Short Protection

If any of  $V_{LED1}$  to  $V_{LED4}$  is 4.5 V or more, the built-in counter operation starts. The clock frequency of counter is the oscillation frequency ( $f_{OSC}$ ), which is determined by  $R_{RT}$ . After it counts 32770, latches off the short LED channel only. When  $f_{osc} = 300 \text{ kHz}$ , the count time is 100 ms and SCP operates after this count time. During PWM dimming, the LED Short Protection is carried out only when PWM = High. If the condition of LED Short is reset while working the counter, the counter resets and LED Short is not detected.

## (8) PWM Low Interval Detect

The low interval of PWM input is counted by built-in counter during EN = High. The clock frequency of counter is the oscillation frequency ( $f_{OSC}$ ), which is determined by  $R_{RT}$ . It stops the operation of circuits except VREG at 32768 counts. When  $f_{OSC} = 300 \text{ kHz}$ , the count time is 100 ms and the Low interval of PWM is detected after this count time.

4. Protection Feature - continued

(9) Output Voltage Discharge Circuit (VOUT Discharge Function)

If start-up with a charge remaining at VOUT, LED might occur flicker. To prevent this, it is necessary to discharge of VOUT when starting-up. If use only resistance for setting OVP to discharge, it takes a lot time for discharging VOUT. Therefore, this product has functionality of circuit for VOUT discharge. VOUT discharge function is available at Buck-Boost application and Buck application. For this case, be sure to connect VOUT and the VDISC pin. It discharges the residual electric charge of VOUT when DC/DC circuit is OFF; changing EN High to Low or operating protect function. The discharge time ( $t_{DISC}$ ) is expressed in the following equations.

$$t_{DISC} = \frac{3 \times VOUT \times C_{OUT}}{4 \times I_{DISC}} \quad [s]$$

where:

- $t_{DISC}$  is the DC/DC converter output discharge time.
- $C_{OUT}$  is the VOUT capacity.
- $VOUT$  is the DC/DC converter output voltage.
- $I_{DISC}$  is the discharge current.

From the graph below, find the  $I_{DISC}$  value in 25 % VOUT voltage, and substitute it in the above equation. For example, substitute  $I_{DISC}$  value in VOUT = 5 V (approximately 76 mA) in the above equation when using in VOUT = 20 V, and calculate the discharge time.

In order to suppress the flickering of the LED, the time of restarting EN = Low should be secured  $t_{DISC}$  or more long.

Always check with actual machine because the  $t_{DISC}$  found here is a reference level.

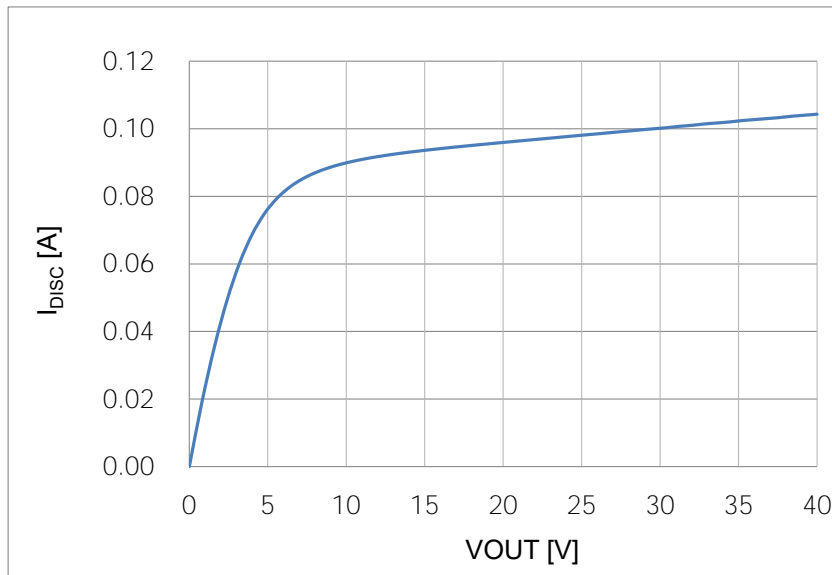

Figure 7.  $I_{DISC}$  vs VOUT

## Absolute Maximum Ratings (Ta = 25 °C)

Parameter	Symbol	Rating	Unit
Power Supply Voltage	VCC	40	V
BOOT, OUTH Pin Voltage	V <sub>BOOT</sub> , V <sub>OUTH</sub>	45	V
SW, CS Pin Voltage	V <sub>SW</sub> , V <sub>CS</sub>	40	V
BOOT-SW Pin Voltage	V <sub>BOOT-SW</sub>	7	V
LED1 to LED4, VDISC Pin Voltage	V <sub>LEDn</sub> (n = 1 to 4), V <sub>VDISC</sub>	40	V
PWM, SYNC, EN Pin Voltage	V <sub>PWM</sub> , V <sub>SYNC</sub> , V <sub>EN</sub>	-0.3 to +7	V
VREG, OVP, FAIL1, FAIL2, SS, RT, SSCG Pin Voltage	V <sub>VREG</sub> , V <sub>OVP</sub> , V <sub>FAIL1</sub> , V <sub>FAIL2</sub> , V <sub>SS</sub> , V <sub>RT</sub> , V <sub>SSCG</sub>	-0.3 to +7 < VCC	V
LEDEN1, LEDEN2, ISET, COMP, OUTL Pin Voltage	V <sub>LEDEN1</sub> , V <sub>LEDEN2</sub> , V <sub>ISET</sub> V <sub>COMP</sub> , V <sub>OUTL</sub>	-0.3 to +7 < V <sub>VREG</sub>	V
Maximum Junction Temperature	T <sub>jmax</sub>	150	°C
Storage Temperature Range	T <sub>stg</sub>	-55 to +150	°C
LED Maximum Output Current	I <sub>LED</sub>	120 <sup>*1</sup>	mA

**Caution 1:** Operating the IC over the absolute maximum ratings may damage the IC. The damage can either be a short circuit between pins or an open circuit between pins and the internal circuitry. Therefore, it is important to consider circuit protection measures, such as adding a fuse, in case the IC is operated over the absolute maximum ratings.

**Caution 2:** Should by any chance the maximum junction temperature rating be exceeded the rise in temperature of the chip may result in deterioration of the properties of the chip. In case of exceeding this absolute maximum rating, design a PCB board with thermal resistance taken into consideration by increasing board size and copper area so as not to exceed the maximum junction temperature rating.

\*1 Current level per channel. Set the LED current that does not over Junction Temperature Range (T<sub>j</sub>) maximum.

Thermal Resistance<sup>\*1</sup>

Parameter	Symbol	Thermal Resistance (Typ)		Unit	
		1s <sup>*3</sup>	2s2p <sup>*4</sup>		
VQFN28SV5050					
Junction to Ambient	θ <sub>JA</sub>	128.50	31.50	°C/W	
Junction to Top Characterization Parameter <sup>*2</sup>	ψ <sub>JT</sub>	12	9	°C/W	
HTSSOP-B28					
Junction to Ambient	θ <sub>JA</sub>	107.00	25.10	°C/W	
Junction to Top Characterization Parameter <sup>*2</sup>	ψ <sub>JT</sub>	6	3	°C/W	
Layer Number of Measurement Board	Material	Board Size			
Single	FR-4	114.3 mm x 76.2 mm x 1.57 mmt			
Top					
Copper Pattern	Thickness				
Footprints and Traces	70 μm				
Layer Number of Measurement Board	Material	Board Size	Thermal Via <sup>*5</sup>		
4 Layers	FR-4	114.3 mm x 76.2 mm x 1.6 mmt	Pitch	Diameter	
			1.20 mm	Φ0.30 mm	
Top		2 Internal Layers		Bottom	
Copper Pattern	Thickness	Copper Pattern	Thickness	Copper Pattern	Thickness
Footprints and Traces	70 μm	74.2 mm x 74.2 mm	35 μm	74.2 mm x 74.2 mm	70 μm

\*1 Based on JESD51-2A(Still-Air)

\*2 The thermal characterization parameter to report the difference between junction temperature and the temperature at the top center of the outside surface of the component package.

\*3 Using a PCB board based on JESD51-3.

\*4 Using a PCB board based on JESD51-5, 7.

\*5 This thermal via connects with the copper pattern of all layers.

## Recommended Operating Conditions

Parameter	Symbol	Min	Typ	Max	Unit
Power Supply Voltage <sup>*1</sup>	VCC	4.5	12	35	V
Operating Temperature	Topr	-40	+25	+125	°C
DC/DC Oscillation Frequency	f <sub>OSC</sub>	200	300	2200	kHz
External Synchronized Frequency <sup>*2</sup> <sup>*3</sup>	f <sub>SYNC</sub>	Higher of 200 or f <sub>OSC</sub> x 0.8	300	Lower of 2200 or f <sub>OSC</sub> x 1.2	kHz
External Synchronized Pulse Duty	D <sub>SYNC</sub>	40	50	60	%

\*1 This indicates the voltage near the VCC pin. Be careful of voltage drop by the impedance of power line.

\*2 When external synchronization frequency is not used, connect the SYNC pin to open or GND.

\*3 When external synchronization frequency is used, do not change to internal oscillation frequency along the way.

## Operating Conditions (External Constant Range)

Parameter	Symbol	Min	Typ	Max	Unit
VREG Capacity	C <sub>VREG</sub>	1.0	2.2	4.7	μF
LED Current Setting Resistance	R <sub>ISET</sub>	41	100	250	kΩ
Oscillation Frequency Setting Resistance	R <sub>RT</sub>	3.6	27	41	kΩ
Soft Start Capacity Setting	C <sub>SS</sub>	0.047	0.1	0.47	μF
Spread Spectrum Setting Capacity	C <sub>SSCG</sub>	4.7	10	47	nF

**Electrical Characteristics**(Unless otherwise specified, VCC = 12 V, Ta = -40 °C to +125 °C)

Parameter	Symbol	Min	Typ	Max	Unit	Conditions
Circuit Current	I <sub>CC</sub>	-	-	10	mA	EN = High, SYNC = High, RT = OPEN, PWM = Low, ISET = OPEN, CIN = 10 μF
Standby Current	I <sub>ST</sub>	-	-	10	μA	EN = Low, VDISC = OPEN
<b>[VREG]</b>						
Reference Voltage	V <sub>VREG</sub>	4.5	5.0	5.5	V	I <sub>VREG</sub> = -5 mA, C <sub>VREG</sub> = 2.2 μF
<b>[OUTH]</b>						
OUTH High Side ON-Resistor	R <sub>ONHH</sub>	1.5	3.5	7.0	Ω	I <sub>OUTH</sub> = -10 mA
OUTH Low Side ON-Resistor	R <sub>ONHL</sub>	0.8	2.5	5.5	Ω	I <sub>OUTH</sub> = 10 mA
OCP Detection Voltage	V <sub>OLIMIT</sub>	VCC-0.22	VCC-0.20	VCC-0.18	V	
この行は削除してください	t <sub>OLIMIT</sub>	-	30	-	ns	V <sub>CS</sub> = VCC-0.5V
<b>[OUTL]</b>						
OUTL High Side ON-Resistor	R <sub>ONLH</sub>	1.5	3.5	10.0	Ω	I <sub>OUTL</sub> = -10 mA
OUTL Low Side ON-Resistor	R <sub>ONLL</sub>	0.8	2.5	5.5	Ω	I <sub>OUTL</sub> = 10 mA
<b>[SW]</b>						
SW ON-Resistor	R <sub>ON_SW</sub>	4.0	10.0	25.0	Ω	I <sub>SW</sub> = 10 mA
<b>[ERRAMP]</b>						
LED Control Voltage	V <sub>LED</sub>	0.9	1.0	1.1	V	
COMP Sink Current	I <sub>COMPSINK</sub>	35	80	145	μA	V <sub>LEDn</sub> = 2 V (n = 1 to 4), V <sub>COMP</sub> = 1 V
COMP Source Current	I <sub>COMPSOURCE</sub>	-145	-80	-35	μA	V <sub>LEDn</sub> = 0.5 V (n = 1 to 4), V <sub>COMP</sub> = 1 V
<b>[Oscillator]</b>						
Oscillation Frequency 1	f <sub>OSC1</sub>	285	300	315	kHz	R <sub>RT</sub> = 27 kΩ
Oscillation Frequency 2	f <sub>OSC2</sub>	1800	2000	2200	kHz	R <sub>RT</sub> = 3.9 kΩ
<b>[OVP]</b>						
OVP Detection Voltage	V <sub>OV1</sub>	1.9	2.0	2.1	V	V <sub>OV1</sub> : Sweep up
OVP Hysteresis Width	V <sub>OVPHYS1</sub>	0.02	0.06	0.10	V	V <sub>OV1</sub> : Sweep down

**Electrical Characteristics - continued**(Unless otherwise specified, VCC = 12 V, Ta = -40 °C to +125 °C)

Parameter	Symbol	Min	Typ	Max	Unit	Conditions
<b>[UVLO]</b>						
UVLO Detection Voltage	V <sub>UVLO</sub>	3.2	3.5	3.8	V	VCC: Sweep down
UVLO Hysteresis Width	V <sub>UHYS</sub>	0.25	0.50	0.75	V	VCC: Sweep up, V <sub>VREG</sub> > 3.5 V
<b>[LED Output]</b>						
LED Current Relative Dispersion	I <sub>LED1</sub>	-3	-	+3	%	I <sub>LED</sub> = 50 mA, Ta = 25 °C ΔI <sub>LED1</sub> = (I <sub>LEDn</sub> /I <sub>LEDn_AVG</sub> -1) × 100 (n = 1 to 4)
		-5	-	+5	%	I <sub>LED</sub> = 50 mA, Ta = -40 °C to +125 °C ΔI <sub>LED1</sub> = (I <sub>LEDn</sub> /I <sub>LEDn_AVG</sub> -1) × 100 (n = 1 to 4)
LED Current Absolute Dispersion	I <sub>LED2</sub>	-3	-	+3	%	I <sub>LED</sub> = 50 mA, Ta = 25 °C ΔI <sub>LED2</sub> = (I <sub>LEDn</sub> /50mA-1) × 100 (n = 1 to 4)
		-5	-	+5	%	I <sub>LED</sub> = 50 mA, Ta = -40 °C to +125 °C ΔI <sub>LED2</sub> = (I <sub>LEDn</sub> /50mA-1) × 100 (n = 1 to 4)
ISET Voltage	V <sub>ISET</sub>	0.9	1.0	1.1	V	R <sub>ISET</sub> = 100 kΩ
PWM Minimum Pulse Width	t <sub>MIN</sub>	1	-	-	μs	f <sub>PWM</sub> = 100 Hz to 20 kHz, I <sub>LED</sub> = 20 mA to 100 mA
PWM Frequency	f <sub>PWM</sub>	0.1	-	20	kHz	
<b>[Protection Circuit]</b>						
LED Open Detection Voltage	V <sub>OPEN</sub>	0.2	0.3	0.4	V	V <sub>LEDn</sub> : (n = 1 to 4) Sweep down
LED Short Detection Voltage	V <sub>SHORT</sub>	4.2	4.5	4.8	V	V <sub>LEDn</sub> : (n = 1 to 4) Sweep up
LED Short Detection Latch OFF Delay Time	t <sub>SHORT</sub>	70	100	130	ms	R <sub>RT</sub> = 27 kΩ
SCP Latch OFF Delay Time	t <sub>SCP</sub>	70	100	130	ms	R <sub>RT</sub> = 27 kΩ
PWM Latch OFF Delay Time	t <sub>PWM</sub>	70	100	130	ms	R <sub>RT</sub> = 27 kΩ
ISET-GND Short Protection Impedance	I <sub>SETPROT</sub>	-	-	4.7	kΩ	
LSDET Detection Voltage	V <sub>LSDET</sub>	-	1.24	-	V	
<b>[Logic Input Voltage]</b>						
Input High Voltage	V <sub>INH</sub>	2.1	-	V <sub>VREG</sub>	V	EN, SYNC, PWM, LEDEN1, LEDEN2
Input Low Voltage	V <sub>INL</sub>	GND	-	0.8	V	EN, SYNC, PWM, LEDEN1, LEDEN2
Input Current	I <sub>IN</sub>	15	50	100	μA	V <sub>IN</sub> = 5 V (EN, SYNC, PWM, LEDEN1, LEDEN2)
<b>[FAIL Output (Open Drain)]</b>						
FAIL Low Voltage	V <sub>OL</sub>	-	0.1	0.2	V	I <sub>FAIL</sub> = 0.1 mA

Typical Performance Curves

(Reference Data. Unless otherwise specified, Ta = -40 °C to +125 °C)

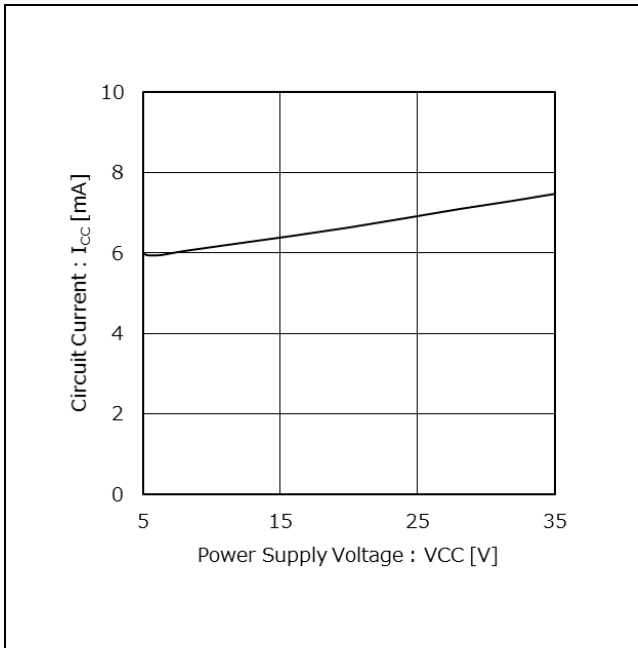

Figure 8. Circuit Current vs Power Supply Voltage (VCC = 4.5 V to 35 V, VEN = 3.3 V, VPWM = 0 V)

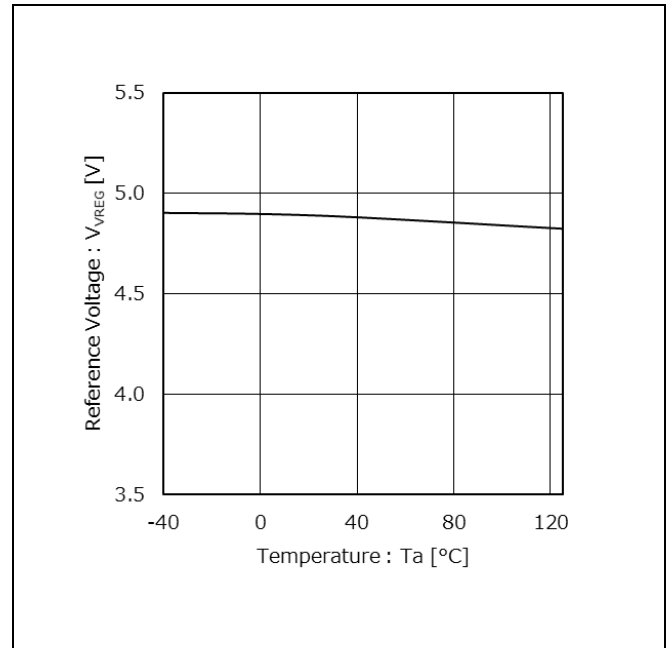

Figure 9. Reference Voltage vs Temperature (VCC = 12 V, VEN = 3.3 V, VPWM = 0 V)

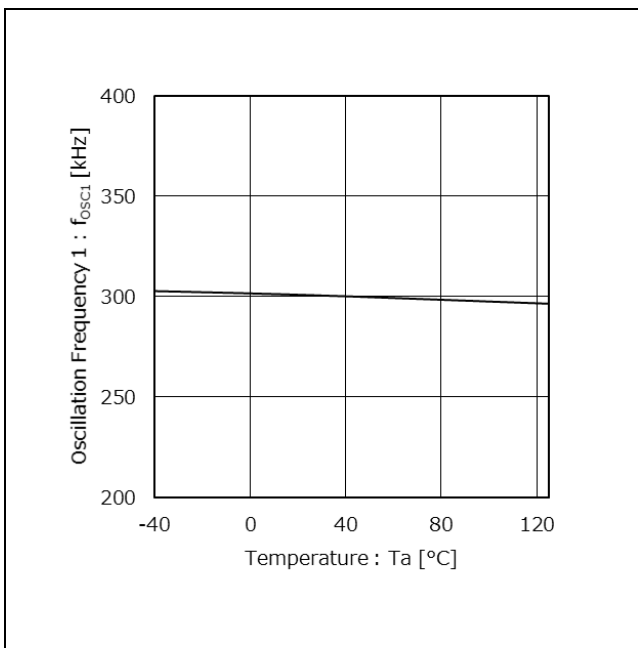

Figure 10. Oscillation Frequency 1 vs Temperature (@300 kHz, VCC = 12 V, VEN = 3.3 V, RRT = 27 kΩ)

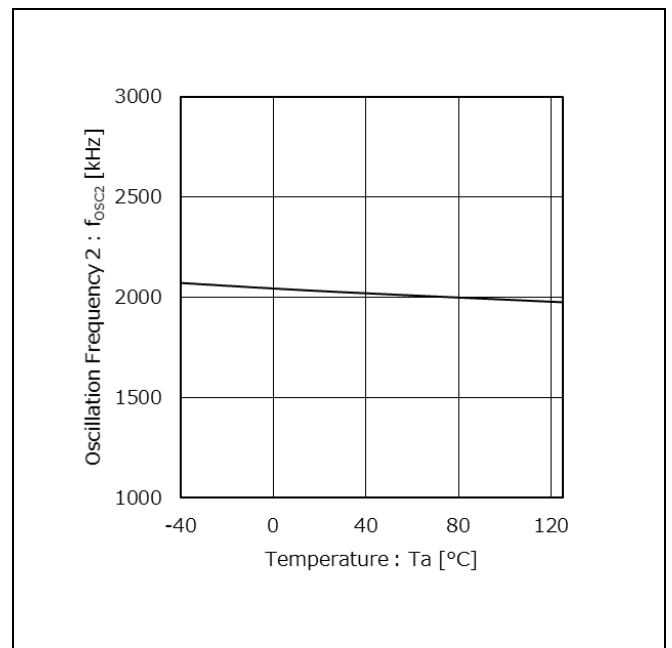

Figure 11. Oscillation Frequency 2 vs Temperature (@2000 kHz, VCC = 12 V, VEN = 3.3 V, RRT = 3.6 kΩ)

Typical Performance Curves - continued

(Reference Data. Unless otherwise specified,  $T_a = -40\text{ }^\circ\text{C}$  to  $+125\text{ }^\circ\text{C}$ )

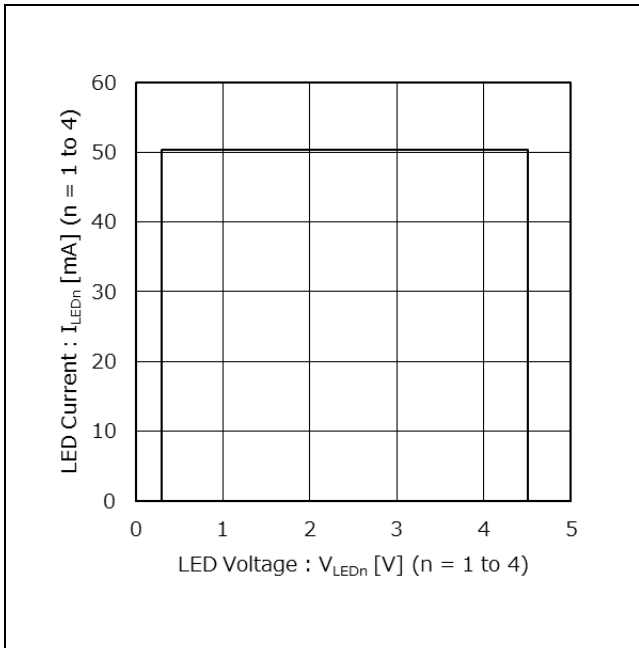

Figure 12. LED Current vs LED Voltage  
( $T_a = 25\text{ }^\circ\text{C}$ ,  $V_{CC} = 12\text{ V}$ ,  $V_{EN} = 3.3\text{ V}$ ,  
 $V_{LEDn} = \text{sweep}$  ( $n = 1$  to  $4$ ))

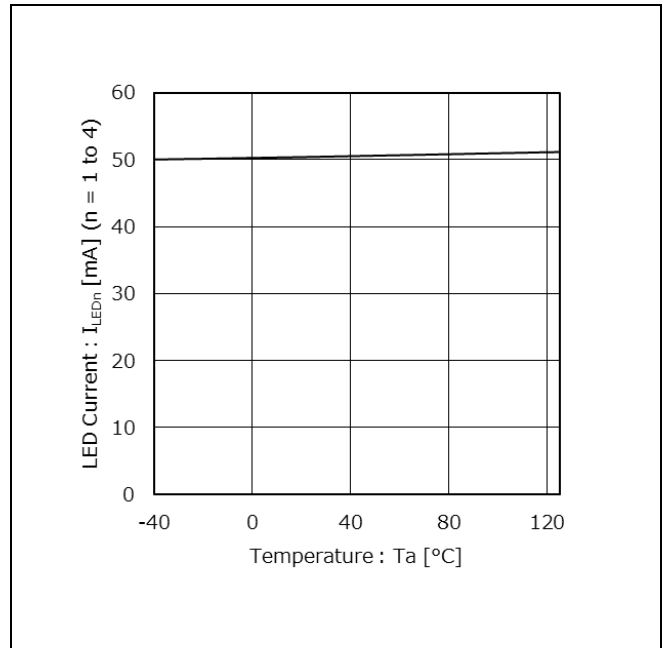

Figure 13. LED Current vs Temperature  
( $V_{CC} = 12\text{ V}$ ,  $V_{EN} = 3.3\text{ V}$ ,  
 $V_{LEDn} = 2\text{ V}$  ( $n = 1$  to  $4$ ),  $V_{PWM} = V_{VREG}$ )

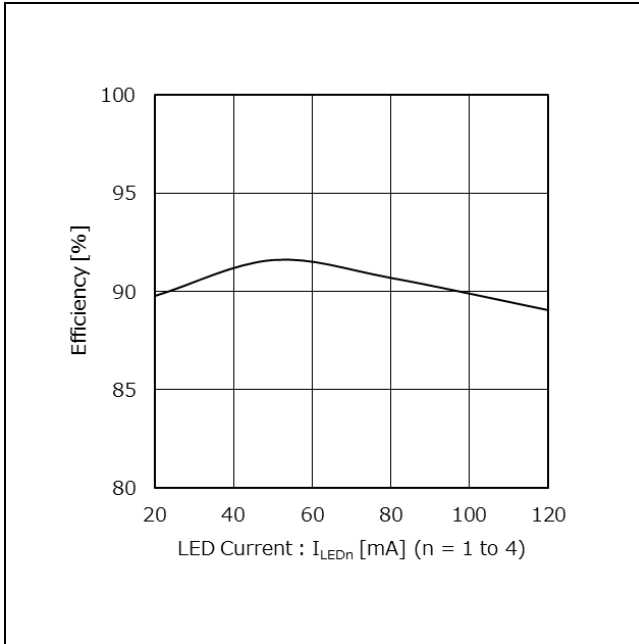

Figure 14. Efficiency vs LED Current( $n = 1$  to  $4$ )  
(Buck-Boost Application)  
( $T_a = 25\text{ }^\circ\text{C}$ ,  $V_{CC} = 12\text{ V}$ ,  $V_{EN} = 3.3\text{ V}$ ,  $V_{PWM} = V_{VREG}$ ,  
4 LED loads per channel, all channels have loads)

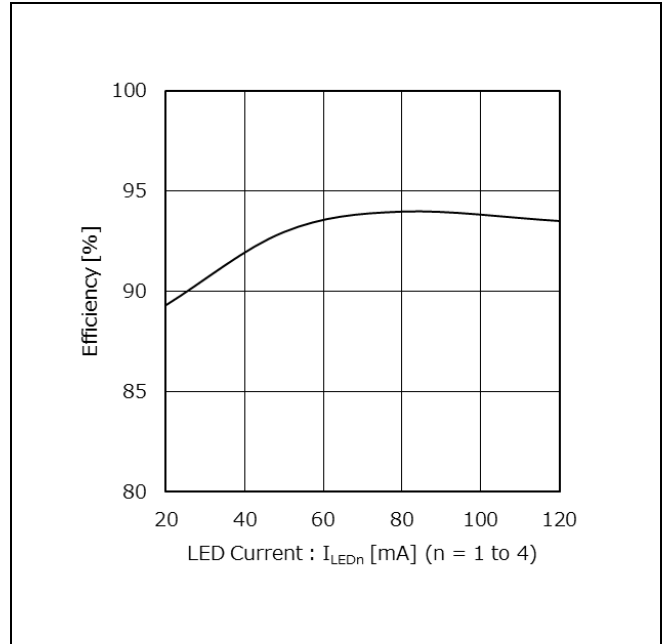
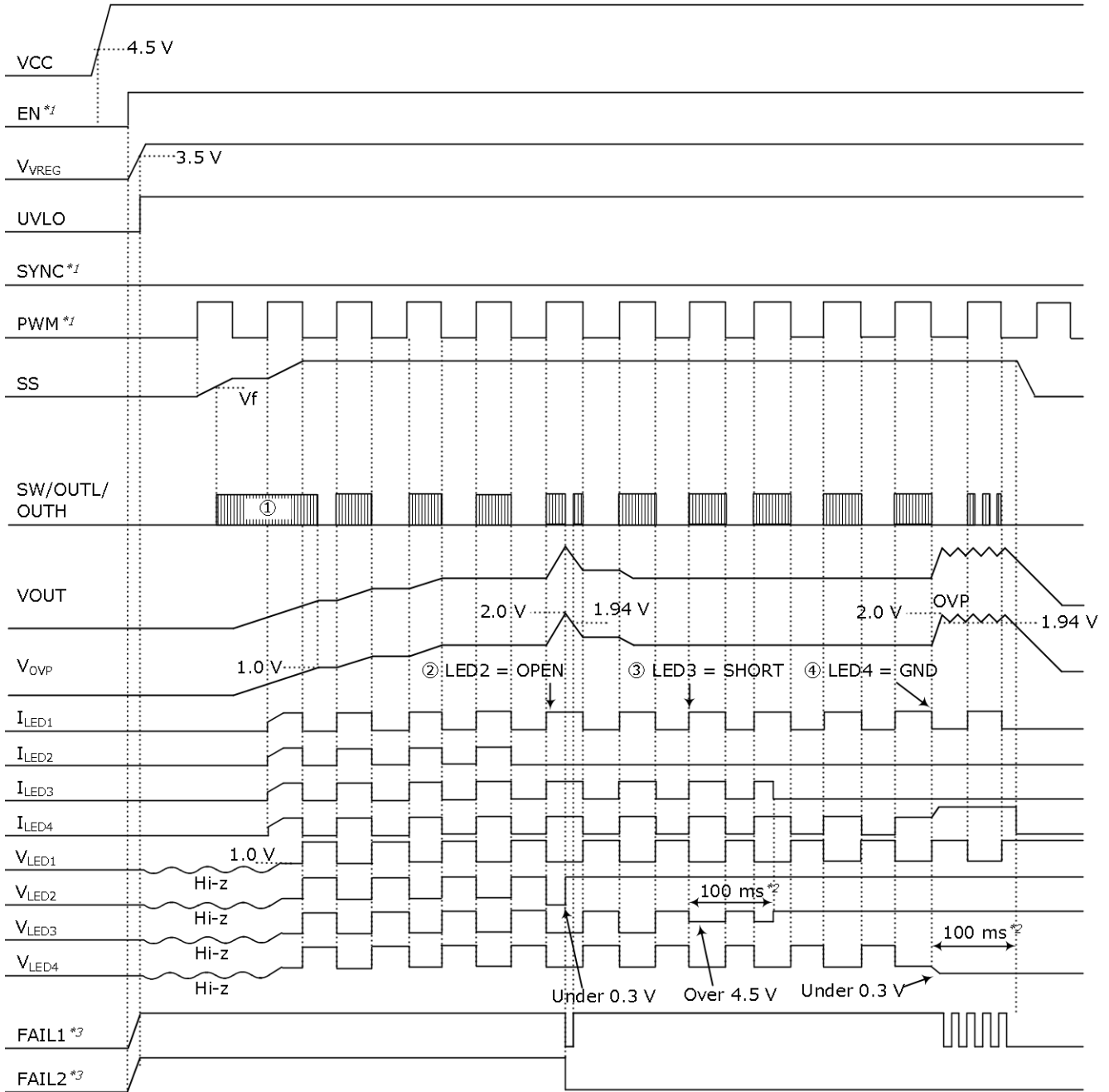

Figure 15. Efficiency vs LED Current( $n = 1$  to  $4$ )  
(Boost Application)  
( $T_a = 25\text{ }^\circ\text{C}$ ,  $V_{CC} = 12\text{ V}$ ,  $V_{EN} = 3.3\text{ V}$ ,  $V_{PWM} = V_{VREG}$ ,  
8 LED loads per channel, all channels have loads)

Timing Chart (Start-up and Protection)



\*1 EN is input after input VCC in the timing chart above, but there is no problem to input EN, PWM, and SYNC before input VCC. EN is judged as Low at V<sub>EN</sub> is 0.8 V or less and as High at V<sub>EN</sub> is 2.1 V or more. Do not use this IC in the condition of V<sub>EN</sub> is between 0.8 V and 2.1 V.

\*2 The count time of 32770 clk x 1/f<sub>osc</sub>. In case of f<sub>osc</sub>=300 kHz, the count time is 100 ms(typ).

\*3 The above timing chart is when the FAIL1 and FAIL2 pins are pulled up to the VREG pin.

- ① When V<sub>OVP</sub> is less than 1.0 V, regardless of PWM input, the DC/DC switching operation is active (Pre-Boost function). And if V<sub>OVP</sub> reaches 1.0 V, the Pre-Boost is finished. Only when PWM is activated, switches to the Normal mode which operates the DC/DC switching.
- ② When V<sub>LED2</sub> is 0.3 V or less and V<sub>OVP</sub> is 2.0 V or more, LED Open Protect is active and LED2 is turned OFF. Then FAIL2 becomes Low.
- ③ If the condition of V<sub>LED3</sub> is 4.5 V or more and passes 100 ms (@f<sub>osc</sub> = 300 kHz), LED3 is turned OFF. Then FAIL2 becomes Low.
- ④ When V<sub>LED4</sub> is shorted to GND, increase the VOUT voltage. Then V<sub>OVP</sub> rises 2.0 V or more and detect OVP. FAIL1 becomes Low. If OVP occurs, DC/DC switching is OFF and decrease the VOUT voltage, then OVP repeats ON/OFF. And DC/DC switching and LED current of each channel is turned OFF after 100 ms by detecting ground short protection. (In case of f<sub>osc</sub> = 300 kHz).

Timing Chart (Start-up and EN Restart)

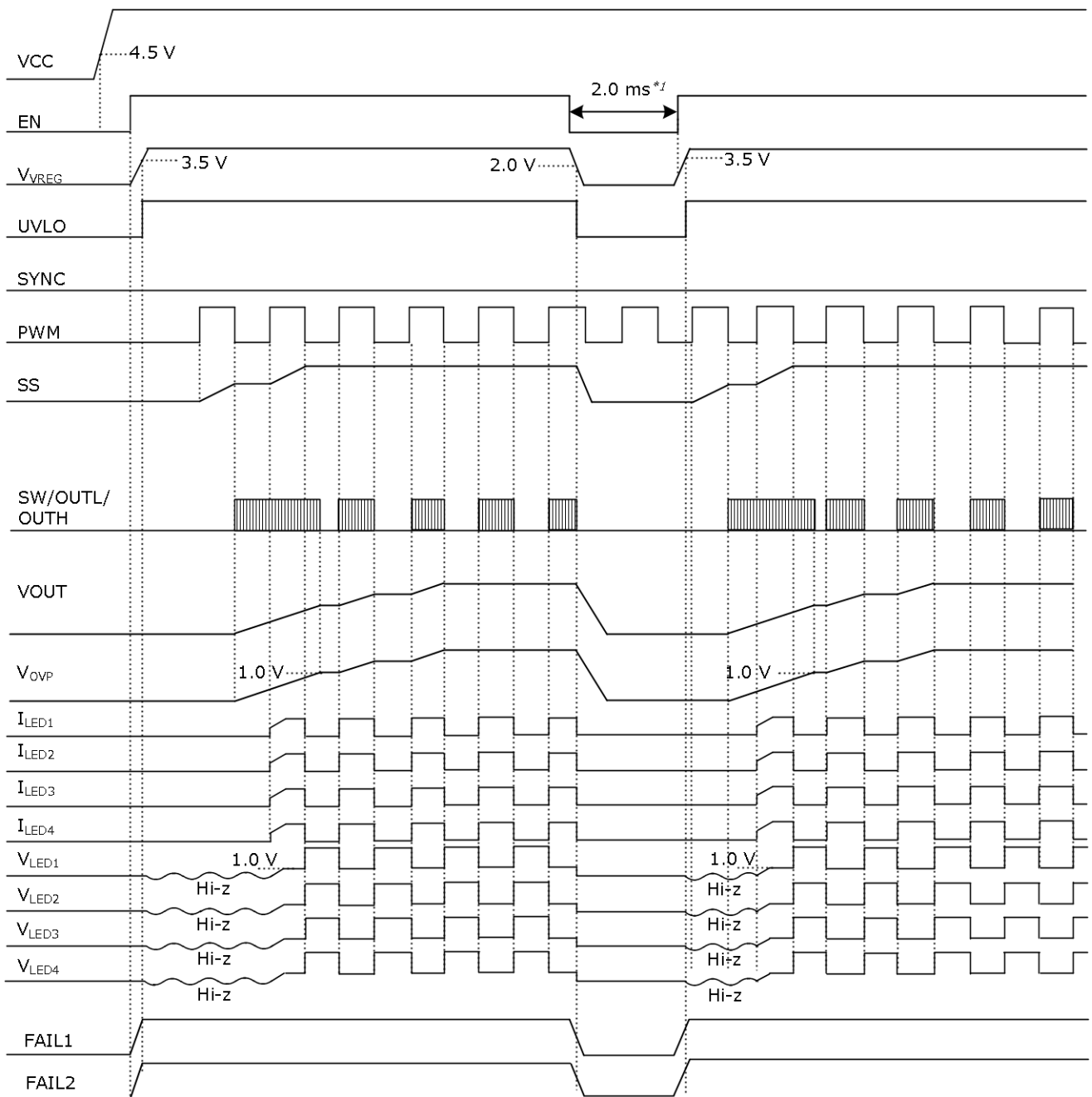

\*1 The Low section during EN restart requires 2.0 ms or more.

Restart after VOUT voltage is discharged. [VOUT discharge function](#) or external discharge switch is recommended. If EN is restarted with remaining VOUT voltage, LED flickering might occur.

Application Examples

When using as Boost DC/DC converter

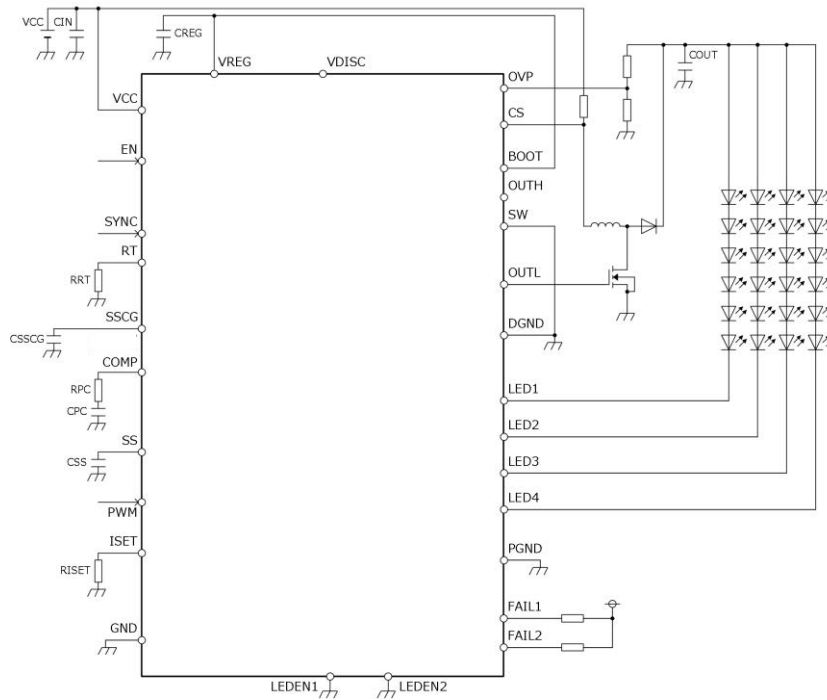

Figure 16. Boost application Circuit

If the VOUT pin or the LED pin is shorted in this case, the overcurrent from  $V_{IN}$  cannot be prevented. To prevent overcurrent, carry out measure such as inserting fuse of which value is OCP setting value or more and is part's rating current or less in between VCC and  $R_{CS}$ .

When using as Buck DC/DC Converter

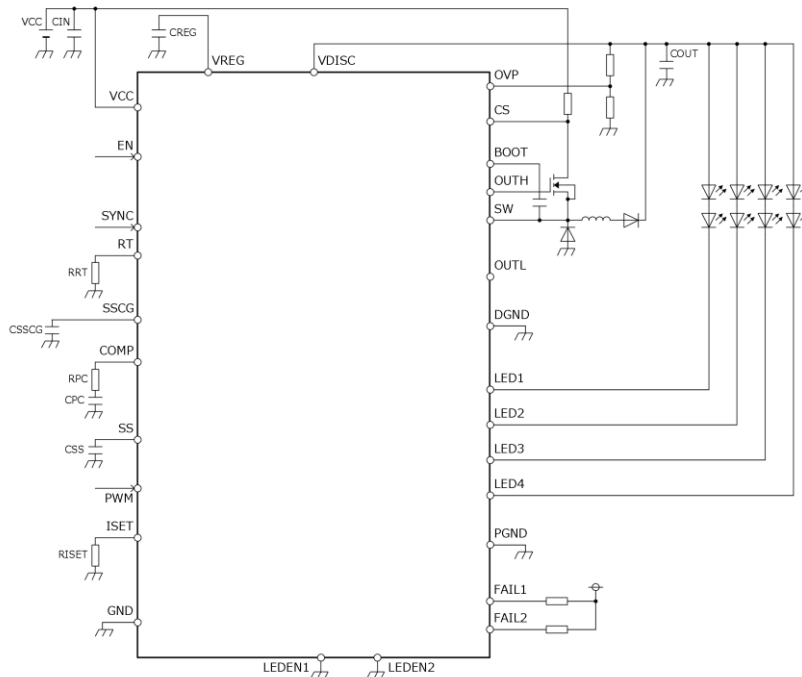

Figure 17. Buck Application Circuit

PCB Application Circuit Diagram

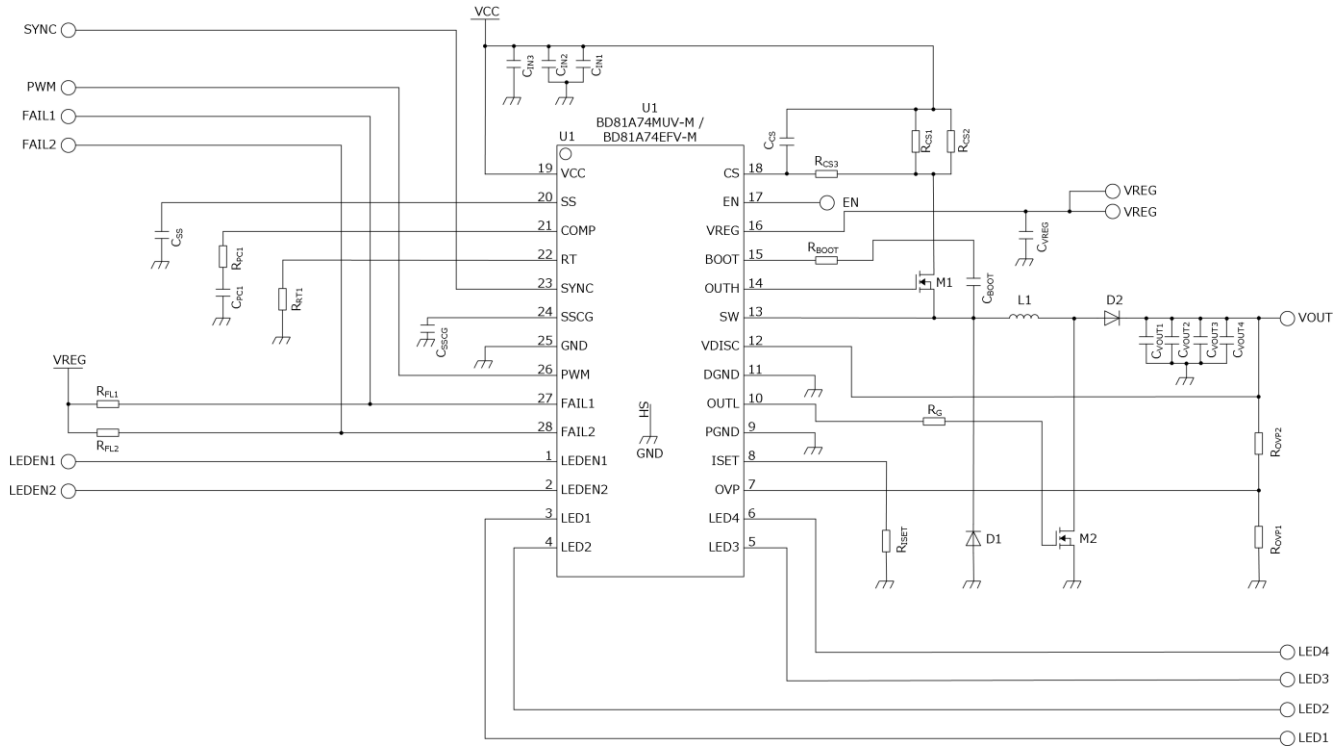

Figure 18. PCB Application Circuit

- Arrange  $R_{RT}$  resistor near the RT pin and do not attach capacitor.
- Arrange  $R_{ISET}$  resistor near the ISET pin and do not attach capacitor.
- Attach the decoupling capacitor of  $C_{IN}$  and  $C_{VREG}$  to IC pin as close as possible.
- Keep the impedance low because large current might flow into DGND and PGND.
- Be careful not to occur noise in the ISET, RT, and COMP pins.
- Since PWM, OUTH, OUTL, SW, SYNC and LED1 to LED4 have switching, avoid affecting the surrounding patterns.
- The SW, OUTH, BOOT pin to each components, keep shortest wiring and minimum impedance.
- There is thermal PAD at the back of package. Solder the board GND for thermal PAD.
- Set the gate resistor of FET (M1) to 0  $\Omega$ . If resistor is connected, M1 OFF timing is delayed in M1 parasitic capacity and gate resistor, and the penetrating current flows to the internal transistor of M1 and SW. The penetrating current might worsen the efficiency or detect OCP.
- To reduce noise, consider the board layout in the shortest wiring and minimum impedance for Boost loop (D2  $\rightarrow$  C<sub>VOUT</sub>  $\rightarrow$  DGND  $\rightarrow$  M2  $\rightarrow$  D2) and Buck loop (VCC  $\rightarrow$  RCS  $\rightarrow$  M1  $\rightarrow$  D1  $\rightarrow$  DGND  $\rightarrow$  GND  $\rightarrow$  C<sub>IN</sub>  $\rightarrow$  VCC).
- The ringing of Low-side FET can be suppressed by  $R_G$ , but there is a concern that efficiency might worsen when  $R_G$  increases. When using  $R_G$ , decide the resistance value after full evaluation.
- When PWM min pulse width satisfies the following formula, please do not connect a capacitor to LED1 to LED4 pins. It might misdetect LED short protection. When the connection of the capacitor is necessary for noise measures, please refer to us.

$$t_{MIN} \leq \frac{10}{f_{OSC}}$$

$t_{MIN}$  : PWM min pulse width       $f_{OSC}$  : DCDC frequency target

- Wire both ends of  $R_{CS1}$  and  $R_{CS2}$  (Red line of below figure) most shortly. If a wiring is long, it may lead to false detection of OCP by an inductance.

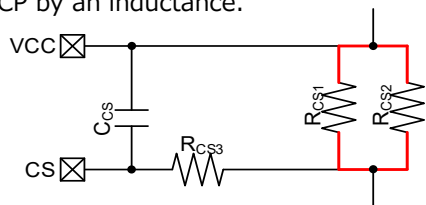

Figure 19. The Case of  $R_{CS}$  Parallel

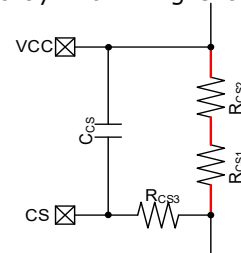

Figure 20. The case of  $R_{CS}$  Series

## PCB Board External Components List (Buck-Boost Application)

Serial No.	Component Name	Component Value	Product Name	Manufacturer
1	C <sub>IN1</sub>	10 $\mu$ F	GCM32EC71H106KA03	Murata
2	C <sub>IN2</sub>	-	-	-
3	C <sub>IN3</sub>	-	-	-
4	R <sub>CS1</sub>	150 m $\Omega$	MCR100JZHFL0R15	Rohm
5	R <sub>CS2</sub>	150 m $\Omega$	MCR100JZHFL0R15	Rohm
6	R <sub>CS3</sub>	Short	-	-
7	C <sub>CS</sub>	-	-	-
8	C <sub>SS</sub>	0.1 $\mu$ F	GCM188R11C104JA01	Murata
9	C <sub>PC1</sub>	0.01 $\mu$ F	GCM188R71H103JA01	Murata
10	R <sub>PC1</sub>	5.1 k $\Omega$	MCR03EZPJ512	Rohm
11	R <sub>RT1</sub>	27 k $\Omega$	MCR03EZPD2702	Rohm
12	C <sub>SSCG</sub>	0.01 $\mu$ F	GCM188R11C103JA01	Murata
13	R <sub>FL1</sub>	100 k $\Omega$	MCR03EZPJ104	Rohm
14	R <sub>FL2</sub>	100 k $\Omega$	MCR03EZPJ104	Rohm
15	C <sub>VREG</sub>	2.2 $\mu$ F	GCM188C71A225KE01	Murata
16	C <sub>BOOT</sub>	0.1 $\mu$ F	GCM188R11C104JA01	Murata
17	R <sub>BOOT</sub>	Short	-	-
18	L1	22 $\mu$ H	CLF10060NIT-220M-D	TDK
19	M1	-	RSS070N05FRA	Rohm
20	M2	-	RSS070N05FRA	Rohm
21	D1	-	RB050L-40DD	Rohm
22	D2	-	RB050L-40DD	Rohm
23	C <sub>VOUT1</sub>	10 $\mu$ F	GCM32EC71H106KA03	Murata
24	C <sub>VOUT2</sub>	10 $\mu$ F	GCM32EC71H106KA03	Murata
25	C <sub>VOUT3</sub>	10 $\mu$ F	GCM32EC71H106KA03	Murata
26	C <sub>VOUT4</sub>	10 $\mu$ F	GCM32EC71H106KA03	Murata
27	R <sub>OV1</sub>	20 k $\Omega$	MCR03EZPD2002	Rohm
28	R <sub>OV2</sub>	360 k $\Omega$	MCR03EZPD3603	Rohm
29	R <sub>ISET</sub>	100 k $\Omega$	MCR03EZPJ104	Rohm
30	R <sub>G</sub>	0 $\Omega$	-	-

\* The above components are modified according to operating conditions and load to be used.

**Selection of Components Externally Connected**

Select the external components following the steps below.

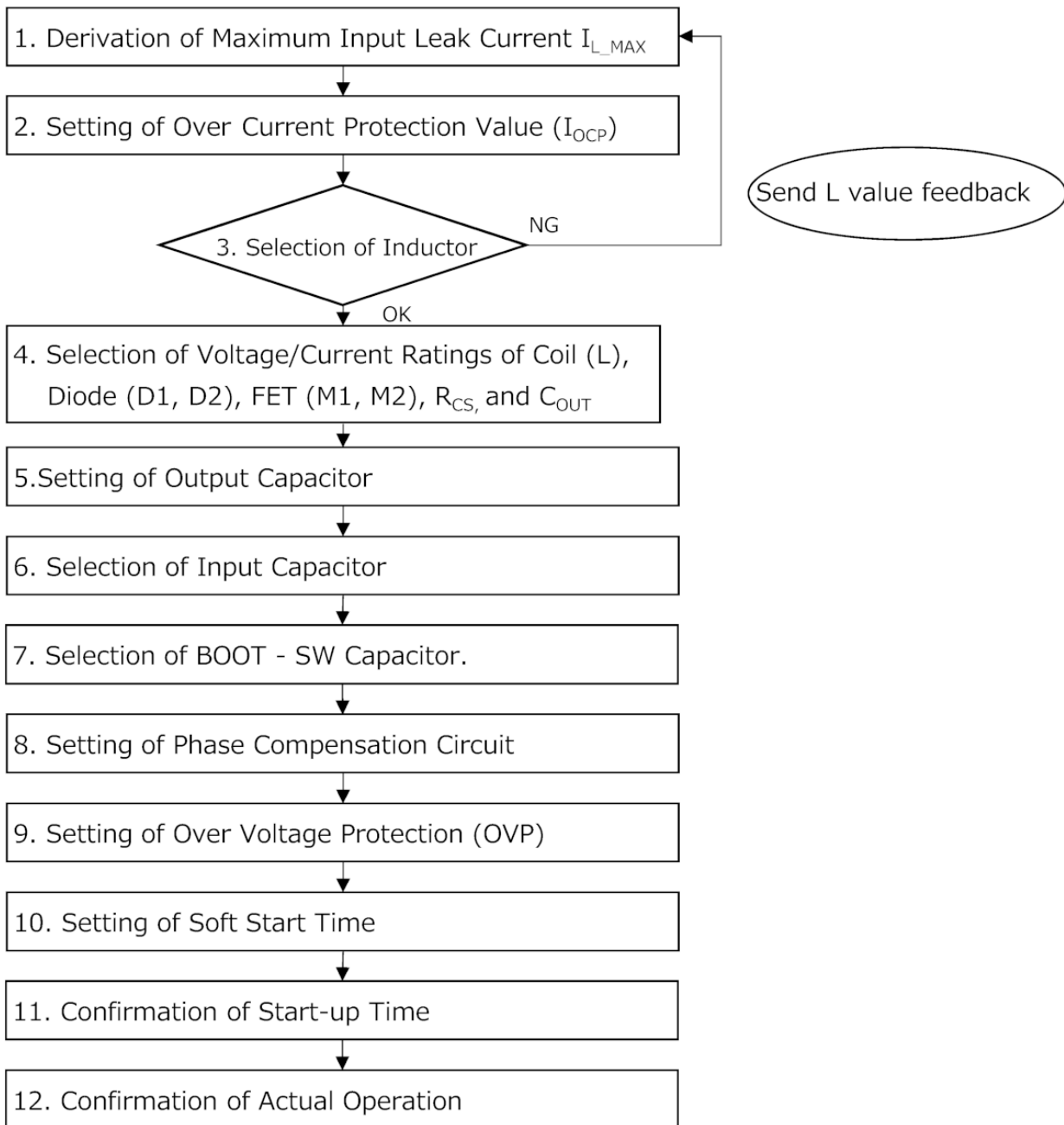

Selection of Components Externally Connected - continued

1. Derivation of Maximum Input Leak Current  $I_{L\_MAX}$

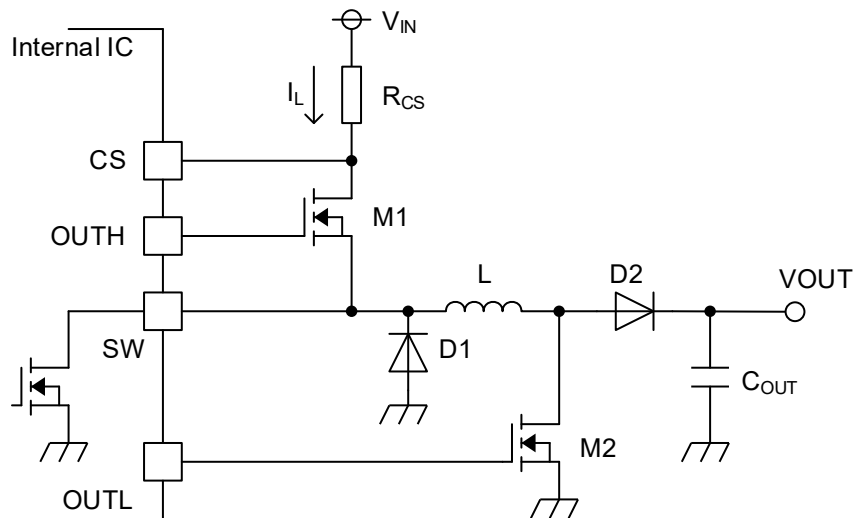

Output Application Circuit Diagram (Buck-Boost Application)

(1) Maximum Output Voltage ( $V_{OUT\_MAX}$ ) Computation

Consider the  $V_f$  variation and number of LED connection in series for  $V_{OUT\_MAX}$  derivation

$$V_{OUT\_MAX} = (V_f + \Delta V_f) \times N + 1.1$$

where:

$V_{OUT\_MAX}$  is the maximum output voltage.

$V_f$  is the LED  $V_f$  voltage.

$\Delta V_f$  is the LED  $V_f$  voltage variation.

$N$  is the LED series number.

(2) Maximum Output Current  $I_{OUT\_MAX}$  Computation

$$I_{OUT\_MAX} = I_{LED} \times 1.05 \times M$$

where:

$I_{OUT\_MAX}$  is the maximum output current.

$I_{LED}$  is the output current per channel.

$M$  is the LED parallel number.

1. Derivation of Maximum Input Leak Current  $I_{L\_MAX}$  - continued(3) Maximum Input Peak Current  $I_{L\_MAX}$  Computation

$$I_{L\_MAX} = I_{L\_AVG} + \frac{1}{2} \Delta I_L$$

where:

- $I_{L\_MAX}$  is the maximum input current.  
 $I_{L\_AVG}$  is the maximum input average current.  
 $\Delta I_L$  is the coil current amplification.

(In case of Boost Application)

$$I_{L\_AVG} = V_{OUT\_MAX} \times \frac{I_{OUT\_MAX}}{\eta \times VCC}$$

$$\Delta I_L = \frac{VCC}{L} \times \frac{1}{f_{OSC}} \times \frac{V_{OUT\_MAX} - VCC}{V_{OUT\_MAX}}$$

(In case of Buck-Boost application)

$$I_{L\_AVG} = (VCC + V_{OUT\_MAX}) \times \frac{I_{OUT\_MAX}}{\eta \times VCC}$$

$$\Delta I_L = \frac{VCC}{L} \times \frac{1}{f_{OSC}} \times \frac{V_{OUT\_MAX}}{VCC + V_{OUT\_MAX}}$$

(In case of Buck application)

$$I_{L\_AVG} = I_{OUT\_MAX} / \eta$$

$$\Delta I_L = \frac{V_{OUT}}{L} \times \frac{1}{f_{OSC}} \times \frac{VCC - V_{OUT\_MAX}}{VCC}$$

where:

- $VCC$  is the supply voltage.  
 $\eta$  is the efficiency.  
 $f_{OSC}$  is the DC/DC oscillation frequency.  
 $L$  is the coil value.

- The worst case for VCC is minimum, so the minimum value should be applied in the equation.
- BD81A74EFV-M / BD81A74MUV-M adopts the current mode DC/DC converter control and is appropriately designed for coil value. The abovementioned value is recommended according to efficiency and stability. If choose the L values outside this recommended range, it not to be guaranteed the stable continuous operation. For example, it may cause irregular switching waveform.
- $\eta$  (efficiency) is around 80 %.

## Selection of Components Externally Connected - continued

### 2. Setting of Over Current Protection Value ( $I_{OCP}$ )

$$I_{OCP} = \frac{V_{OCP\_MIN}}{R_{CS}} > I_{L\_MAX} \quad [A]$$

where:

$I_{OCP\_MIN}$  is the overcurrent protection detect voltage.

$V_{OCP\_MIN}$  is the overcurrent protection detect voltage (0.18 V).

$R_{CS}$  is the current detect resistance.

$I_{L\_MAX}$  is the maximum input peak current.

$R_{CS}$  should be selected by the above equation.

### 3. Selection of Inductor

In order to achieve stable operation of the current mode DC/DC converter, it is recommended adjusting the L value within the range indicated below.

$$0.05 < \frac{V_{OUT} \times R_{CS}}{L \times 10^6} < \frac{0.63 \times f_{OSC}}{10^6} \quad [V/\mu s]$$

where:

$V_{OUT}$  is the DC/DC converter output voltage.

$R_{CS}$  is the current detect resistance.

$L$  is the coil value.

$f_{OSC}$  is the DC/DC oscillation frequency.

Consider the deviation of L value and set with enough margins.

It is more stable by reducing the value of  $\frac{V_{OUT} \times R_{CS}}{L \times 10^6}$ , however it slows down the response time.

Also, the following equation should be satisfied during coil selection in case it is used in  $VCC = 5$  V or less.

$$L < \frac{12 \times VCC \times VCC \times \eta}{V_{OUT} \times I_{LED} \times M \times f_{OSC}}$$

where:

$L$  is the coil value.

$VCC$  is the supply voltage.

$\eta$  is the efficiency.

$V_{OUT}$  is the DC/DC converter output voltage.

$I_{LED}$  is the LED current per channel.

$f_{OSC}$  is the DC/DC oscillation frequency.

$M$  is the LED parallel number.

LED intensity may drop when a coil which does not satisfy the above is chosen.

## Selection of Components Externally Connected - continued

4. Selection of Voltage/Current Ratings of Coil (L), Diode (D1, D2), FET (M1, M2), R<sub>CS</sub>, and C<sub>OUT</sub>

	Current Rating	Voltage Rating	Heat Loss
Coil L	> I <sub>L_MAX</sub>	-	-
Diode D1	> I <sub>OCP</sub>	> V <sub>CC_MAX</sub>	-
Diode D2	> I <sub>OCP</sub>	> V <sub>OVP_MAX</sub>	-
FET M1	> I <sub>OCP</sub>	> V <sub>CC_MAX</sub>	-
FET M2	> I <sub>OCP</sub>	> V <sub>OVP_MAX</sub>	-
R <sub>CS</sub>	-	-	> I <sub>OCP</sub> <sup>2</sup> × R <sub>CS</sub>
C <sub>OUT</sub>	-	> V <sub>OVP_MAX</sub>	-

Consider deviation of external parts and set with enough margins.

In order to achieve fast switching, choose the FET's with smaller gate-capacitance.

## 5. Setting of Output Capacitor

Select the output capacitor C<sub>OUT</sub> based on the requirements of the ripple voltage V<sub>OUTpp</sub>.

$$V_{OUTpp} = \frac{20 \times I_{LED} \times M}{f_{OSC} \times C_{VOUT} \times \eta} + \Delta I_L \times R_{ESR} \quad [V]$$

where:

V<sub>OUTpp</sub> is the VOUT ripple voltage.

I<sub>LED</sub> is the LED current per channel.

M is the LED parallel number.

f<sub>OSC</sub> is the DC/DC oscillation frequency.

C<sub>VOUT</sub> is the VOUT capacity.

η is the efficiency.

ΔI<sub>L</sub> is the coil current amplification.

R<sub>ESR</sub> is the equivalent series resistance of output capacitor C<sub>OUT</sub>.

The actual VOUT ripple voltage is affected by PCB layout and external components characteristics. Therefore, check with the actual machine, and design a capacity with enough margins to fit in allowable ripple voltage. The maximum value of C<sub>OUT</sub> that can be set is 500 μF.

## 6. Selection of Input Capacitor

An input capacitor which is 10 μF or more with low ESR ceramic capacitor is recommended. An input capacitor which is not recommended may cause large ripple voltage at the input and hence lead to malfunction of the IC.

## 7. Selection of BOOT - SW Capacitor

When using the Buck-Boost application or Buck application, insert 0.1 μF capacitor between the BOOT pin and the SW pin.

## Selection of Components Externally Connected - continued

## 8. Setting of Phase Compensation Circuit

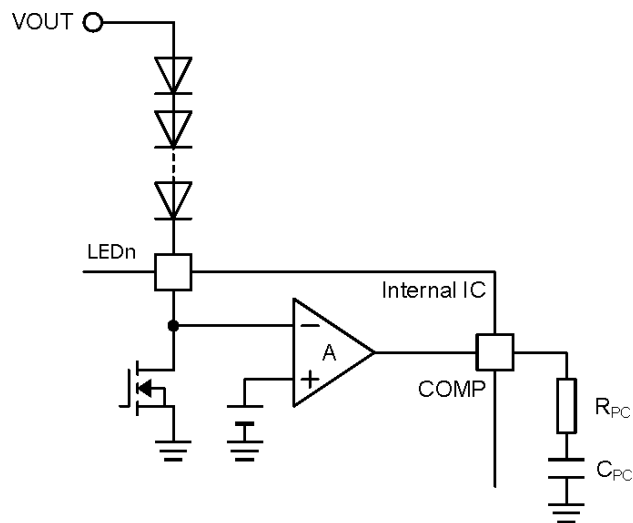

COMP Pin Application Schematic(n = 1 to 4)

## Stability Condition of Application

The stability in LED voltage feedback system is achieved when the following conditions are met.

- (1) When gain is 1 (0 dB), the phase delay is 150° or less (or simply, phase margin is 30° or more).
- (2) When gain is 1 (0 dB), the frequency (Unity Gain Frequency) is 1/10 or less of switching frequency.

To assure stability based on phase margin adjustment is setting the Phase-lead  $f_z$  close to unity gain frequency. In addition, the Phase-lag  $f_{p1}$  is decided based on  $C_{OUT}$  and output impedance  $R_L$ .

The respective formulas are as follows.

$$\text{Phase-lead} \quad f_z = 1/(2\pi R_{PC} C_{PC}) \quad [\text{Hz}]$$

$$\text{Phase-lag} \quad f_{p1} = 1/(2\pi R_L C_{OUT}) \quad [\text{Hz}]$$

\* The output impedance that is calculated in  $R_L = V_{OUT}/I_{OUT}$

To make a good result, set  $f_z$  between 1 kHz to 10 kHz. Substitute the value in the maximum load for  $R_L$ . Further, this setting is easily obtained, and the adjustment with the actual machine may be necessary because it is not strictly calculated. In case of mass production design, thorough confirmation with the actual machine is necessary because these characteristics can change based on board layout, load condition and etc.

Selection of Components Externally Connected - continued

9. Setting of Over Voltage Protection (OVP)

Over voltage protection (OVP) is set from the external resistance  $R_{OVP1}$ ,  $R_{OVP2}$ .

The setting described below is important in the either boost, buck and buck-boost applications.

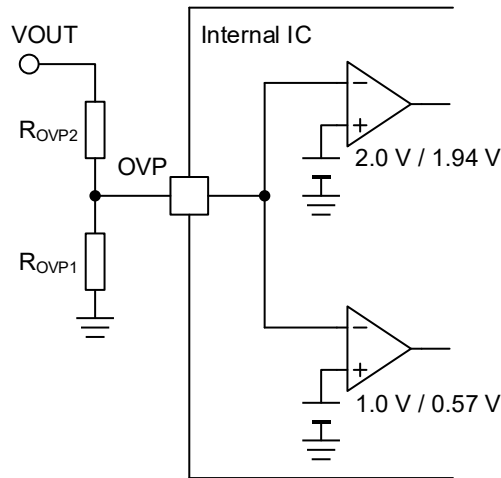

OVP Application Circuit

The OVP pin detects the over voltage when it is 2.0 V (Typ) or more and stops the DC/DC switching. In addition, it detects the open condition when the OVP pin is at 2.0 V (Typ) or more and the LED1 to LED4 pins voltage is at 0.3 V (Typ) or less, and the circuit is latched to OFF (Refer to [Protection Feature](#)). In preventing error in detection of OPEN, it is necessary that the resistor divide voltage of the maximum value of output voltage shall be less than the minimum value of OPEN detection voltage.

Set the  $R_{OVP1}$ ,  $R_{OVP2}$  in such a way the formula shown below can be met.

$$V_{OUT}(Max) \times \frac{R_{OVP1}}{(R_{OVP1} + R_{OVP2})} < V_{OVPOpen}(Min) \dots \dots \dots (1)$$

where:

$V_{OUT}$  is the DC/DC output voltage.

$V_{OVPOpen}$  is the OVP pin open detection voltage.

Example 1: When  $V_f = 3.2 \text{ V} \pm 0.3 \text{ V}$  LED is used in 8 series

$$V_{OUT}(Max) = 1.1(LED \text{ control voltage Max}) + (3.2 + 0.3) \times 8 = 29.1 \text{ [V]}$$

Open Detection OVP Pin Voltage  $V_{OVPOpen}(Min) = 1.9 \text{ [V]}$

If  $R_{OVP1} = 20 \text{ k}\Omega$ , set by  $R_{OVP2} > 286.3 \text{ k}\Omega$  from (1).

Example 2: When  $V_f = 3.2 \text{ V} \pm 0.3 \text{ V}$  LED is used in 3series

$$V_{OUT}(Max) = 1.1(LED \text{ control voltage Max}) + (3.2 + 0.3) \times 3 = 11.6 \text{ [V]}$$

Open Detection OVP Pin Voltage  $V_{OVPOpen}(Min) = 1.9 \text{ [V]}$

If  $R_{OVP1} = 20 \text{ k}\Omega$ , set by  $R_{OVP2} > 102.1 \text{ k}\Omega$  from (1).

Selection of Components Externally Connected - continued

10. Setting of Soft Start Time

The soft start circuit is necessary to prevent increase of the coil current and overshoot of the output during the start-up. A capacitance in the range of 0.047 μF to 0.47 μF is recommended. A capacitance less than 0.047 μF may cause overshoot at the output voltage. On the other hand, a capacitance more than 0.47 μF may cause massive reverse current through the parasitic elements when power supply is OFF and may damage the IC.

Soft start time  $t_{SS}$  (Typ).

$$t_{SS} = C_{SS} \times 3.3 / (5 \times 10^{-6}) \quad [s]$$

where:

$C_{SS}$  is the Capacitance at the SS pin.

11. Confirmation of Start-up Time

If the PWM duty is smaller at start-up, the start-up time becomes longer. It is effective to reduce the  $C_{PC}$  value to shorten start-up time, however, confirmation of the phase margin is necessary. PWM duty and data of start-up time in typical 2 conditions are shown below.

Condition 1 (Boost)

VCC = 12 V, VOUT = 30 V (assume 8 LED's series),  $R_{RT} = 27 \text{ k}\Omega$  ( $f_{OSC} = 300 \text{ kHz}$ ),  $R_{ISET} = 100 \text{ k}\Omega$  ( $I_{LED} = 50 \text{ mA}$ ),  $C_{PC} = 0.01 \text{ }\mu\text{F}$ ,  $R_{PC} = 5.1 \text{ k}\Omega$ ,  $C_{SS} = 0.1 \text{ }\mu\text{F}$ ,  $R_{OVP1} = 20 \text{ k}\Omega$ ,  $R_{OVP2} = 360 \text{ k}\Omega$

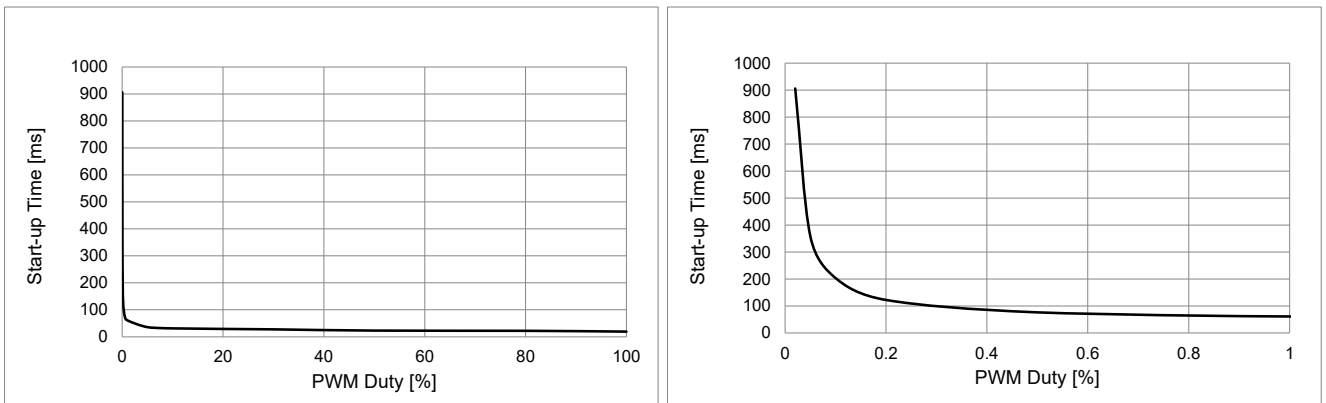

Figure 21. Start-up Time(Boost) vs PWM Duty

Condition 2 (Buck-Boost)

VCC = 12 V, VOUT = 20 V (assume 5 LED's series),  $R_{RT} = 27 \text{ k}\Omega$  ( $f_{OSC} = 300 \text{ kHz}$ ),  $R_{ISET} = 100 \text{ k}\Omega$  ( $I_{LED} = 50 \text{ mA}$ ),  $C_{PC} = 0.01 \text{ }\mu\text{F}$ ,  $R_{PC} = 5.1 \text{ k}\Omega$ ,  $C_{SS} = 0.1 \text{ }\mu\text{F}$ ,  $R_{OVP1} = 30 \text{ k}\Omega$ ,  $R_{OVP2} = 360 \text{ k}\Omega$

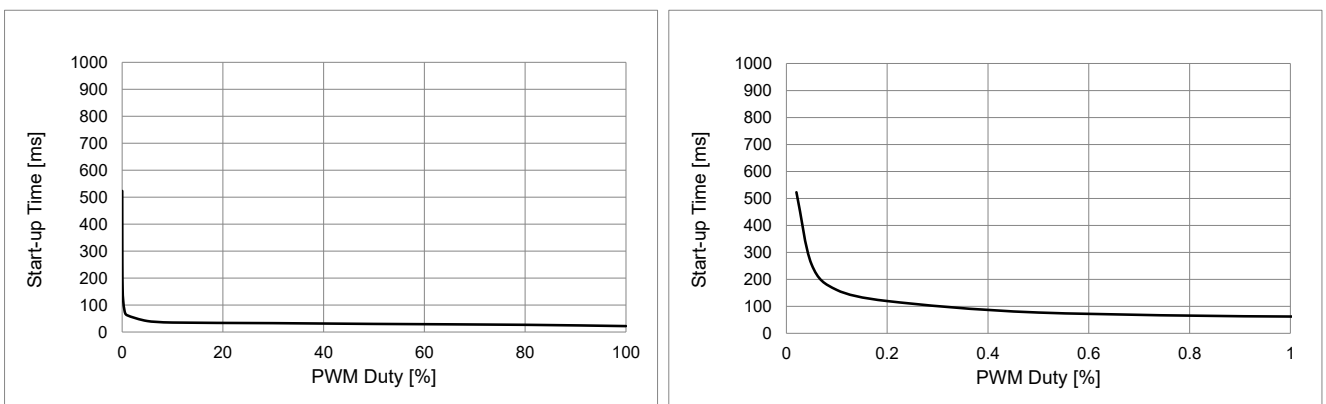

Figure 22. Start-up Time(Buck-Boost) vs PWM Duty

The above are reference data. Always confirm by machine operation because the actual start-up time depends on layout pattern, component constant, and component characteristics.

## Selection of Components Externally Connected - continued

### 12. Confirmation of Actual Operation

Set up the external components value by procedures and attentions mentioned above. However, those settings above are not guaranteed because these are theoretically calculated and it does not include the external parts' variation or characteristics changing. The overall characteristics may change depend on power supply voltage, LED current, LED number, inductance, output capacitance, switching frequency, and PCB layout. We strongly recommend verifying your design by taking the actual measurements.

#### Additional parts for EMC

The example of EMC countermeasure components is shown in the chart below.

1. The resistance for adjusting Slew Rate of high side FET
2. The capacitor for reducing current loop noise of high side FET.
3. The capacitor for reducing noise of high frequency on power line.
4. The low pass filter for reducing noise of power line.
5. The common mode filter for reducing noise of power line.
6. The snubber circuit for reducing noise of high frequency of low side FET.
7. The snubber circuit for reducing ringing of low side FET switching.

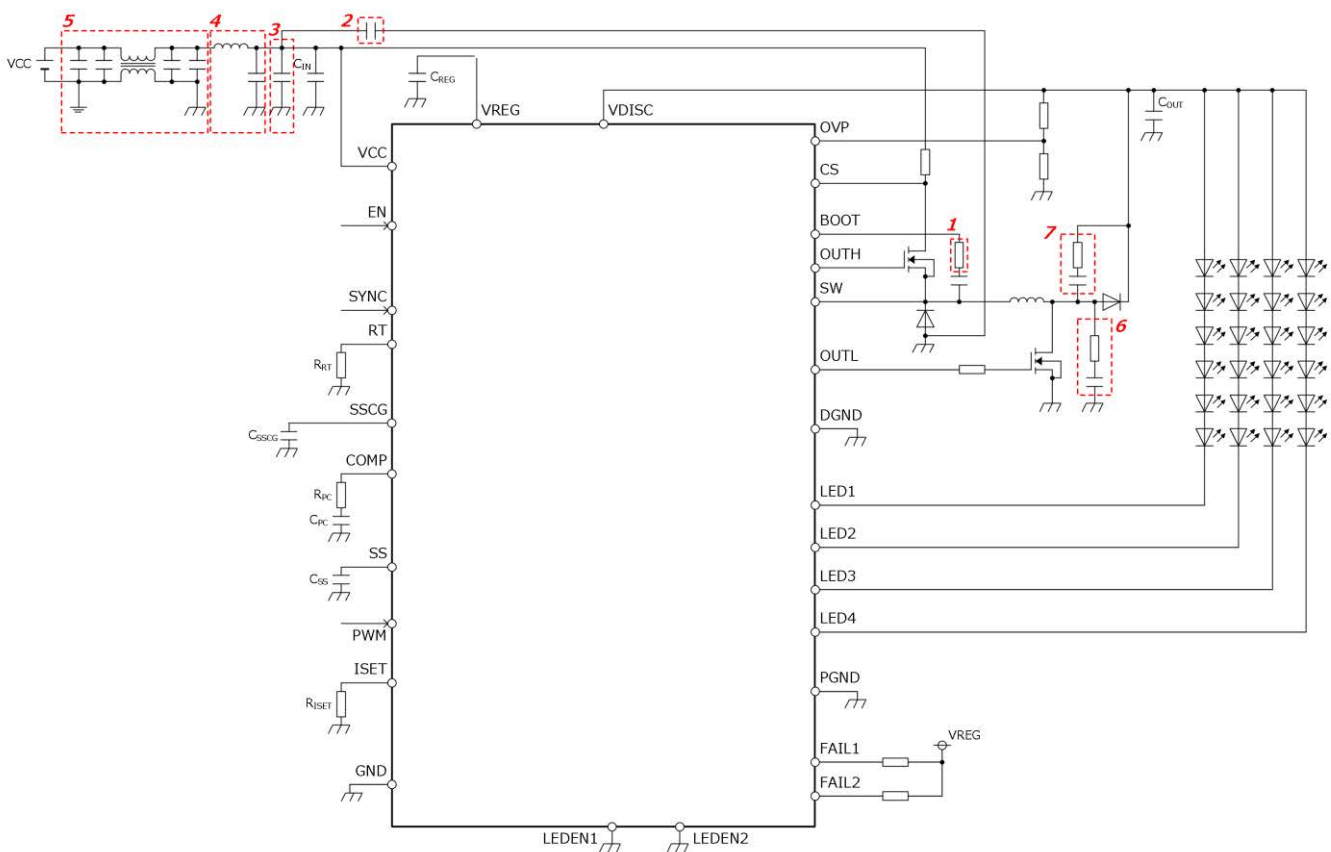

Application Circuit Reference Example (Including EMC Countermeasure Components)

It is basically non-recommended to connect a capacitor to the LED1 to LED4 pins. Please refer to [PCB Application Circuit](#). When the connection of the capacitor is necessary for noise measures, please refer to us.

**Precautions on PCB Layout**

The layout pattern greatly affects the efficiency and ripple characteristics. Therefore, it is necessary to examine carefully when designing. As show in the figure below, Buck-Boost DC/DC converter has two loops; “Loop1” and “Loop2”. The parts in each loop have to be set as near as possible to each other. (For example, GND of C<sub>OUT</sub> and DGND should be very near, GND of C<sub>IN</sub> and GND of D1 should be very near and so on.) Moreover, the wirings of each loop should be as low impedance as possible.

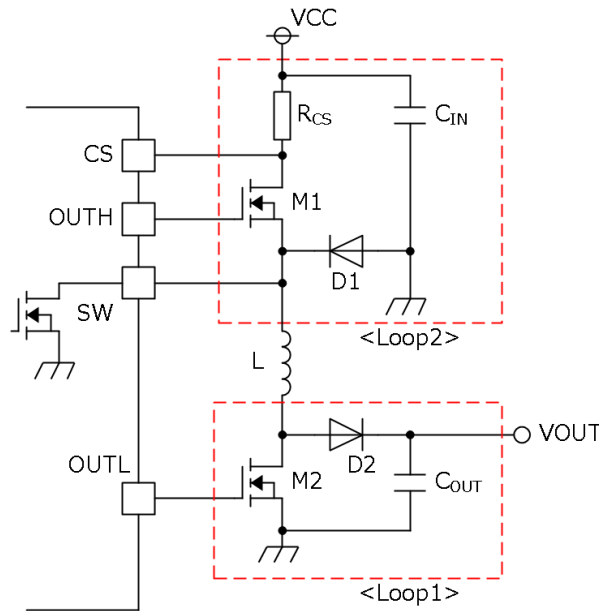

Figure 23. Circuit of DC/DC Block

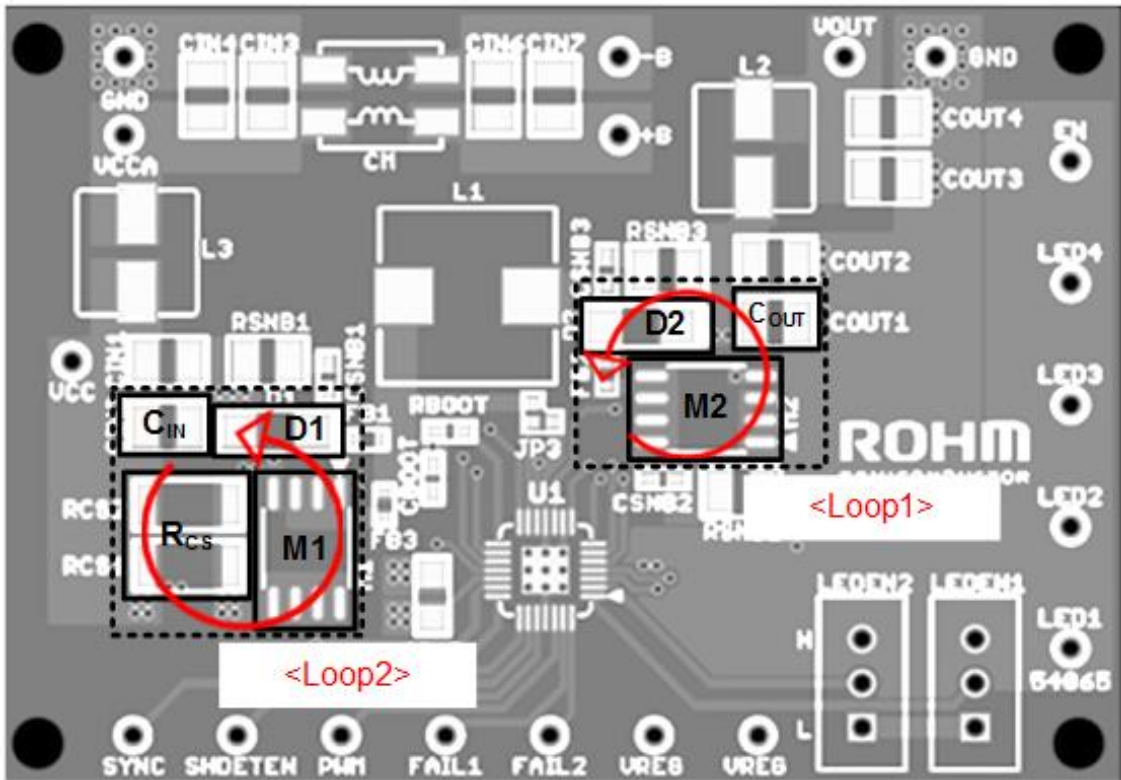

Figure 24. BD81A74MUV-M PCB TOP-layer

### Calculation Example of Power Consumption (Case of Buck-Boost application)

$$\begin{aligned}
 P_C &= I_{CC} \times V_{CC} && \dots (1) \text{ Circuit Power} \\
 &+ C_{ISS1} \times V_{VREG} \times f_{OSC} \times V_{VREG} && \dots (2) \text{ External Boost FET Power} \\
 &+ C_{ISS2} \times V_{VREG} \times f_{OSC} \times V_{VREG} && \dots (3) \text{ External Buck FET Power} \\
 &+ \{V_{LED} \times M + \Delta Vf \times N \times (M-1)\} \times I_{LED} && \dots (4) \text{ Current Driver Power}
 \end{aligned}$$

where:

$P_C$	is the IC power consumption.
$I_{CC}$	is the circuit current.
$V_{CC}$	is the supply voltage.
$C_{ISS1}$	is the External boost FET gate capacity.
$C_{ISS2}$	is the External buck FET gate capacity.
$V_{VREG}$	is the VREG voltage.
$f_{OSC}$	is the switching frequency.
$V_{LED}$	is the LED control voltage.
$I_{LED}$	is the LED output current.
$M$	is the LED parallel number.
$\Delta Vf$	is the LED Vf tolerance of each strings.
$N$	is the LED series number.

<Sample Calculation>

$I_{CC} = 10 \text{ mA}$ ,  $V_{CC} = 12 \text{ V}$ ,  $C_{ISS1} = 2000 \text{ pF}$ ,  $C_{ISS2} = 2000 \text{ pF}$ ,  $V_{VREG} = 5 \text{ V}$ ,  $f_{OSC} = 2200 \text{ kHz}$ ,  $V_{LED} = 1 \text{ V}$ ,  
 $I_{LED} = 50 \text{ mA}$ ,  $M = 4$ ,  $\Delta Vf = 0.1 \text{ V}$ ,  $N = 5$

$$\begin{aligned}
 P_C &= 10 \text{ mA} \times 12 \text{ V} \\
 &+ 2000 \text{ pF} \times 5 \text{ V} \times 2200 \text{ kHz} \times 5 \text{ V} \\
 &+ 2000 \text{ pF} \times 5 \text{ V} \times 2200 \text{ kHz} \times 5 \text{ V} \\
 &+ \{1.0 \times 4 + 0.1 \times 5 \times (4-1)\} \times 50 \text{ mA} = 0.615 \text{ [W]}
 \end{aligned}$$

The above is a simple calculation and the value may differ from the actual value.

I/O Equivalence Circuit

<p>SS</p>	<p>COMP</p>	<p>RT</p>
<p>SYNC, PWM</p>	<p>SSCG</p>	<p>LEDEN1, LEDEN2</p>
<p>FAIL1, FAIL2</p>	<p>LED1, LED2, LED3, LED4</p>	<p>OVP</p>
<p>ISET</p>	<p>OUTL</p>	<p>VDISC</p>
<p>SW</p>	<p>OUTH</p>	<p>BOOT</p>
<p>VREG</p>	<p>EN</p>	<p>CS</p>

\*All values are Typ value

## Operational Notes

- 1. Reverse Connection of Power Supply**

Connecting the power supply in reverse polarity can damage the IC. Take precautions against reverse polarity when connecting the power supply, such as mounting an external diode between the power supply and the IC's power supply pins.
- 2. Power Supply Lines**

Design the PCB layout pattern to provide low impedance supply lines. Furthermore, connect a capacitor to ground at all power supply pins. Consider the effect of temperature and aging on the capacitance value when using electrolytic capacitors.
- 3. Ground Voltage**

Except for pins the output and the input of which were designed to go below ground, ensure that no pins are at a voltage below that of the ground pin at any time, even during transient condition.
- 4. Ground Wiring Pattern**

When using both small-signal and large-current ground traces, the two ground traces should be routed separately but connected to a single ground at the reference point of the application board to avoid fluctuations in the small-signal ground caused by large currents. Also ensure that the ground traces of external components do not cause variations on the ground voltage. The ground lines must be as short and thick as possible to reduce line impedance.
- 5. Recommended Operating Conditions**

The function and operation of the IC are guaranteed within the range specified by the recommended operating conditions. The characteristic values are guaranteed only under the conditions of each item specified by the electrical characteristics.
- 6. Inrush Current**

When power is first supplied to the IC, it is possible that the internal logic may be unstable and inrush current may flow instantaneously due to the internal powering sequence and delays, especially if the IC has more than one power supply. Therefore, give special consideration to power coupling capacitance, power wiring, width of ground wiring, and routing of connections.
- 7. Testing on Application Boards**

When testing the IC on an application board, connecting a capacitor directly to a low-impedance output pin may subject the IC to stress. Always discharge capacitors completely after each process or step. The IC's power supply should always be turned off completely before connecting or removing it from the test setup during the inspection process. To prevent damage from static discharge, ground the IC during assembly and use similar precautions during transport and storage.
- 8. Inter-pin Short and Mounting Errors**

Ensure that the direction and position are correct when mounting the IC on the PCB. Incorrect mounting may result in damaging the IC. Avoid nearby pins being shorted to each other especially to ground, power supply and output pin. Inter-pin shorts could be due to many reasons such as metal particles, water droplets (in very humid environment) and unintentional solder bridge deposited in between pins during assembly to name a few.

## Operational Notes - continued

## 9. Unused Input Pins

Input pins of an IC are often connected to the gate of a MOS transistor. The gate has extremely high impedance and extremely low capacitance. If left unconnected, the electric field from the outside can easily charge it. The small charge acquired in this way is enough to produce a significant effect on the conduction through the transistor and cause unexpected operation of the IC. So unless otherwise specified, unused input pins should be connected to the power supply or ground line.

## 10. Regarding the Input Pin of the IC

This monolithic IC contains P+ isolation and P substrate layers between adjacent elements in order to keep them isolated. P-N junctions are formed at the intersection of the P layers with the N layers of other elements, creating a parasitic diode or transistor. For example (refer to figure below):

When  $GND > Pin A$  and  $GND > Pin B$ , the P-N junction operates as a parasitic diode.

When  $GND > Pin B$ , the P-N junction operates as a parasitic transistor.

Parasitic diodes inevitably occur in the structure of the IC. The operation of parasitic diodes can result in mutual interference among circuits, operational faults, or physical damage. Therefore, conditions that cause

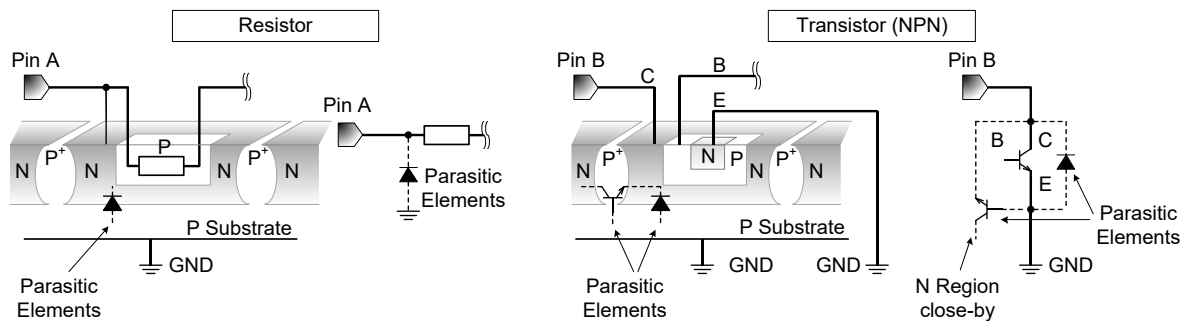

these diodes to operate, such as applying a voltage lower than the GND voltage to an input pin (and thus to the P substrate) should be avoided.

Figure 25. Example of monolithic IC structure

## 11. Ceramic Capacitor

When using a ceramic capacitor, determine a capacitance value considering the change of capacitance with temperature and the decrease in nominal capacitance due to DC bias and others.

## 12. Thermal Shutdown Circuit (TSD)

This IC has a built-in thermal shutdown circuit that prevents heat damage to the IC. Normal operation should always be within the IC's maximum junction temperature rating. If however the rating is exceeded for a continued period, the junction temperature ( $T_j$ ) will rise which will activate the TSD circuit that will turn OFF power output pins. When the  $T_j$  falls below the TSD threshold, the circuits are automatically restored to normal operation.

Note that the TSD circuit operates in a situation that exceeds the absolute maximum ratings and therefore, under no circumstances, should the TSD circuit be used in a set design or for any purpose other than protecting the IC from heat damage.

Operational Notes - continued

13. Over Current Protection Circuit (OCP)

This IC incorporates an integrated overcurrent protection circuit that is activated when the load is shorted. This protection circuit is effective in preventing damage due to sudden and unexpected incidents. However, the IC should not be used in applications characterized by continuous operation or transitioning of the protection circuit.

Ordering Information

B D 8 1 A 7 4 E F V	-	M E 2
Package EFV: HTSSOP-B28		Product Rank M: for Automotive Packaging and forming specification E2: Embossed carrier tape
B D 8 1 A 7 4 M U V	-	M E 2
Package MUV: VQFN28SV5050		Product Rank M: for Automotive Packaging and forming specification E2: Embossed carrier tape

Marking Diagram

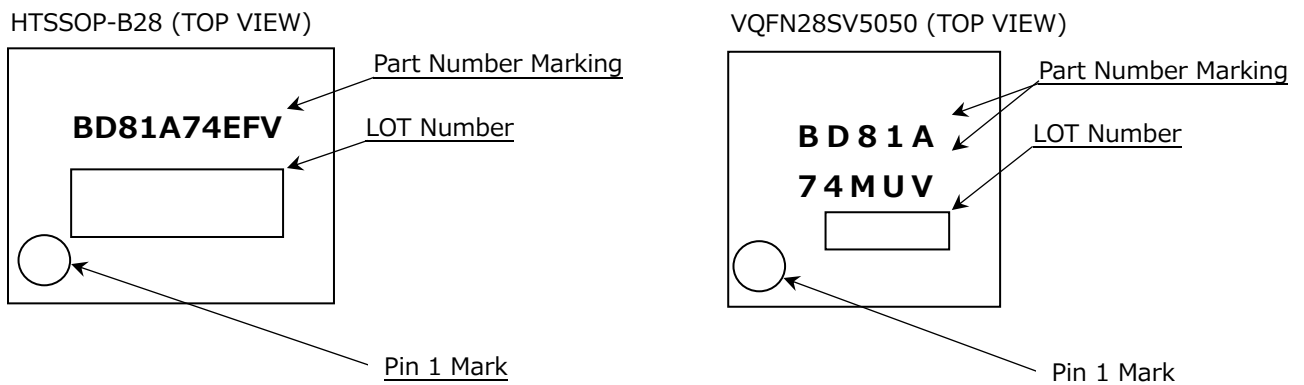

Marking	Package	Orderable Part Number
BD81A74EFV	HTSSOP-B28	BD81A74EFV-ME2
BD81A74MUV	VQFN28SV5050	BD81A74MUV-ME2

Physical Dimension and Packing Information

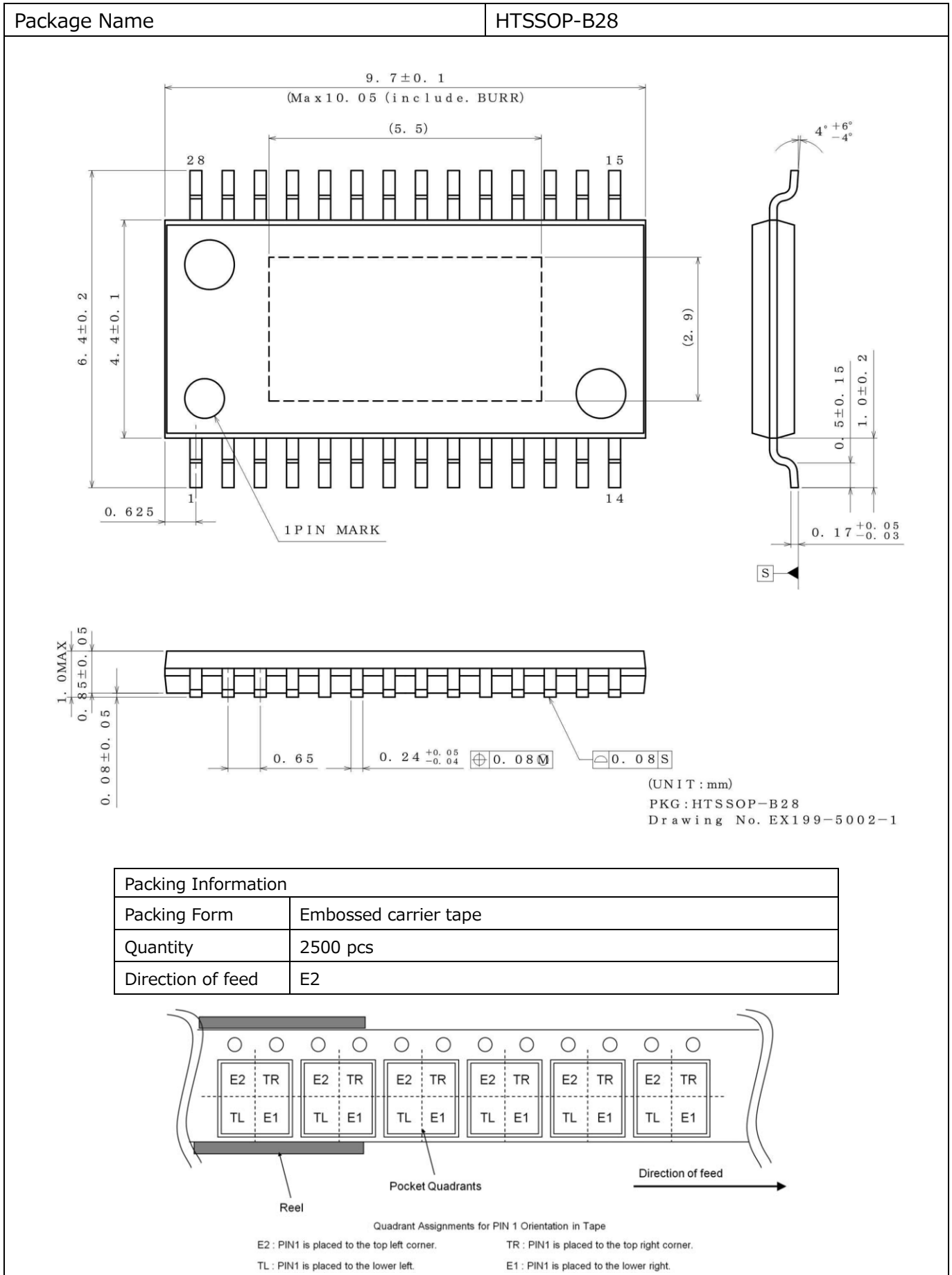

Physical Dimension and Packing Information - continued

Package Name	VQFN28SV5050
--------------	--------------

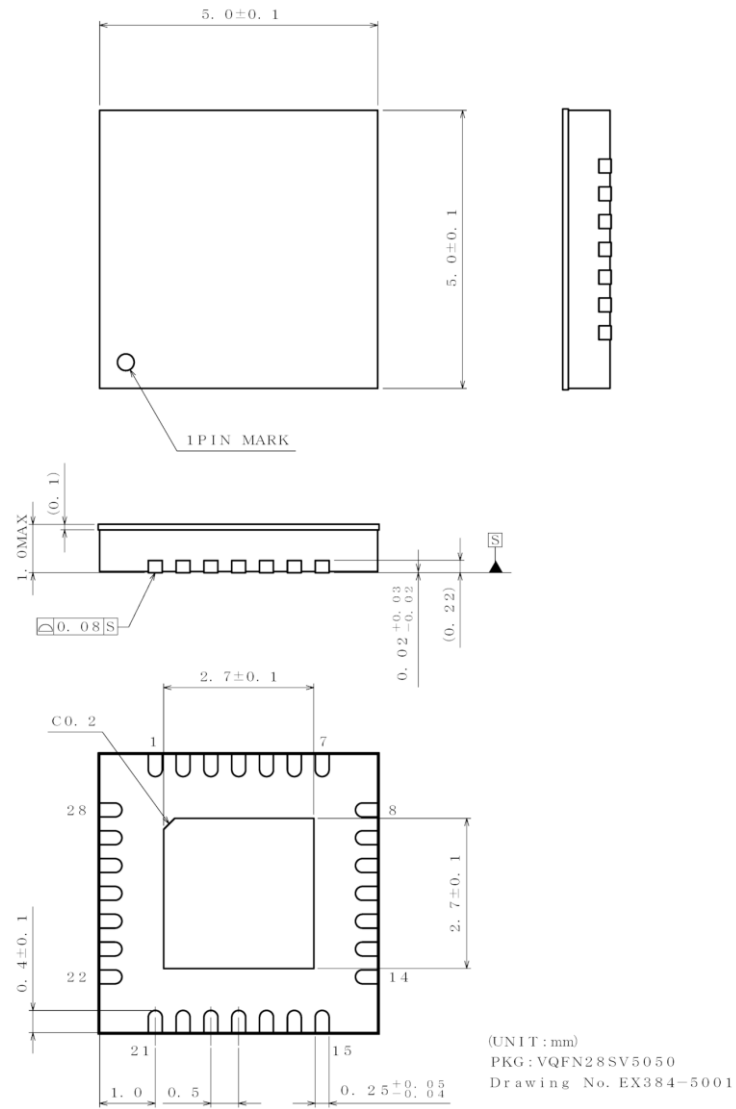

Packing Information	
Packing Form	Embossed carrier tape
Quantity	2500 pcs
Direction of feed	E2

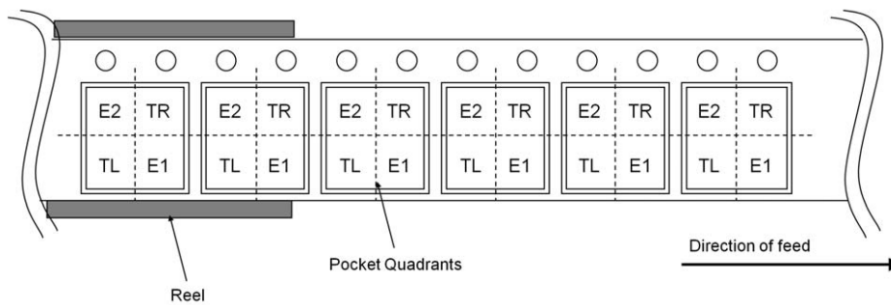

Quadrant Assignments for PIN 1 Orientation in Tape  
 E2 : PIN1 is placed to the top left corner.      TR : PIN1 is placed to the top right corner.  
 TL : PIN1 is placed to the lower left.          E1 : PIN1 is placed to the lower right.

## Revision History

Date	Revision	Details
25.Sep.2017	001	New Release
25.Oct.2017	002	<p>P.1 General Description Change to "Light modulation (10,000:1@100Hz dimming function) is possible by PWM input."</p> <p>P.1 Key Specifications Change to "LED Maximum Dimming Ratio 10,000:1@100Hz".</p> <p>P.14 PWM Minimum Pulse Width, Conditions Change to "fPWM = 100Hz to 20kHz".</p> <p>P.14 PWM Frequency, Min Change to "0.1kHz".</p>
5.Dec.2018	003	<p>P.1 Add words ○This product is protected by U.S. Patent No.7,235,954, No.7,541,785, No.7,944,189.</p> <p>P.8 Add "(8) DC/DC switching control at over voltage output (LSDET)" and "(9) PWM pulse and DC/DC switching"</p>
2.Sep.2019	004	P.5 Add <Caution of Large LED Current Setting>
10.Apr.2020	005	<p>Format update</p> <p>Change the sentence about "Spread Spectrum Function" (Before) The band of the switching frequency becomes 90 %±10 % of ... (After) The band of the switching frequency becomes 100 % to 80 % ...</p> <p>Change the calculation of noise reduction S.</p> <p>Added Figure19, Figure20 and calculation. Added the following sentence to the description of "PCB Application Circuit Diagram" When PWM min pulse width satisfies the following formula, please do not connect a capacitor to LED1 to LED4 pins. It might misdetect LED short protection. When the connection of the capacitor is necessary for noise measures, please refer to us.</p> $t_{\text{MIN}} \leq 10/f_{\text{OSC}}$ <p><math>t_{\text{MIN}}</math> : PWM min pulse width      <math>f_{\text{OSC}}</math> : DCDC frequency target</p> <p>Added the following sentence to "Selection of Components Externally Connected"/"Confirmation of Actual Operation" It is basically non-recommended to connect a capacitor to the LED1 to LED4 pins. Please refer to PCB Application Circuit. When the connection of the capacitor is necessary for noise measures, please refer to us.</p>
12.Feb.2021	006	<p>P.7 Figure 4 X axis name Before : <math>R_{\text{RT}} [\Omega]</math> After : <math>R_{\text{RT}} [k\Omega]</math></p>
8.Oct.2021	007	<p>P.1 Typical Application Circuit Modified the right side of the figure broke off.</p>

# Notice

## Precaution on using ROHM Products

1. If you intend to use our Products in devices requiring extremely high reliability (such as medical equipment <sup>(Note 1)</sup>, aircraft/spacecraft, nuclear power controllers, etc.) and whose malfunction or failure may cause loss of human life, bodily injury or serious damage to property ("Specific Applications"), please consult with the ROHM sales representative in advance. Unless otherwise agreed in writing by ROHM in advance, ROHM shall not be in any way responsible or liable for any damages, expenses or losses incurred by you or third parties arising from the use of any ROHM's Products for Specific Applications.

(Note1) Medical Equipment Classification of the Specific Applications

JAPAN	USA	EU	CHINA
CLASS III	CLASS III	CLASS II b	CLASS III
CLASS IV		CLASS III	

2. ROHM designs and manufactures its Products subject to strict quality control system. However, semiconductor products can fail or malfunction at a certain rate. Please be sure to implement, at your own responsibilities, adequate safety measures including but not limited to fail-safe design against the physical injury, damage to any property, which a failure or malfunction of our Products may cause. The following are examples of safety measures:
  - [a] Installation of protection circuits or other protective devices to improve system safety
  - [b] Installation of redundant circuits to reduce the impact of single or multiple circuit failure
3. Our Products are not designed under any special or extraordinary environments or conditions, as exemplified below. Accordingly, ROHM shall not be in any way responsible or liable for any damages, expenses or losses arising from the use of any ROHM's Products under any special or extraordinary environments or conditions. If you intend to use our Products under any special or extraordinary environments or conditions (as exemplified below), your independent verification and confirmation of product performance, reliability, etc, prior to use, must be necessary:
  - [a] Use of our Products in any types of liquid, including water, oils, chemicals, and organic solvents
  - [b] Use of our Products outdoors or in places where the Products are exposed to direct sunlight or dust
  - [c] Use of our Products in places where the Products are exposed to sea wind or corrosive gases, including Cl<sub>2</sub>, H<sub>2</sub>S, NH<sub>3</sub>, SO<sub>2</sub>, and NO<sub>2</sub>
  - [d] Use of our Products in places where the Products are exposed to static electricity or electromagnetic waves
  - [e] Use of our Products in proximity to heat-producing components, plastic cords, or other flammable items
  - [f] Sealing or coating our Products with resin or other coating materials
  - [g] Use of our Products without cleaning residue of flux (Exclude cases where no-clean type fluxes is used. However, recommend sufficiently about the residue.); or Washing our Products by using water or water-soluble cleaning agents for cleaning residue after soldering
  - [h] Use of the Products in places subject to dew condensation
4. The Products are not subject to radiation-proof design.
5. Please verify and confirm characteristics of the final or mounted products in using the Products.
6. In particular, if a transient load (a large amount of load applied in a short period of time, such as pulse, is applied, confirmation of performance characteristics after on-board mounting is strongly recommended. Avoid applying power exceeding normal rated power; exceeding the power rating under steady-state loading condition may negatively affect product performance and reliability.
7. De-rate Power Dissipation depending on ambient temperature. When used in sealed area, confirm that it is the use in the range that does not exceed the maximum junction temperature.
8. Confirm that operation temperature is within the specified range described in the product specification.
9. ROHM shall not be in any way responsible or liable for failure induced under deviant condition from what is defined in this document.

## Precaution for Mounting / Circuit board design

1. When a highly active halogenous (chlorine, bromine, etc.) flux is used, the residue of flux may negatively affect product performance and reliability.
2. In principle, the reflow soldering method must be used on a surface-mount products, the flow soldering method must be used on a through hole mount products. If the flow soldering method is preferred on a surface-mount products, please consult with the ROHM representative in advance.

For details, please refer to ROHM Mounting specification

### Precautions Regarding Application Examples and External Circuits

1. If change is made to the constant of an external circuit, please allow a sufficient margin considering variations of the characteristics of the Products and external components, including transient characteristics, as well as static characteristics.
2. You agree that application notes, reference designs, and associated data and information contained in this document are presented only as guidance for Products use. Therefore, in case you use such information, you are solely responsible for it and you must exercise your own independent verification and judgment in the use of such information contained in this document. ROHM shall not be in any way responsible or liable for any damages, expenses or losses incurred by you or third parties arising from the use of such information.

### Precaution for Electrostatic

This Product is electrostatic sensitive product, which may be damaged due to electrostatic discharge. Please take proper caution in your manufacturing process and storage so that voltage exceeding the Products maximum rating will not be applied to Products. Please take special care under dry condition (e.g. Grounding of human body / equipment / solder iron, isolation from charged objects, setting of ionizer, friction prevention and temperature / humidity control).

### Precaution for Storage / Transportation

1. Product performance and soldered connections may deteriorate if the Products are stored in the places where:
  - [a] the Products are exposed to sea winds or corrosive gases, including Cl<sub>2</sub>, H<sub>2</sub>S, NH<sub>3</sub>, SO<sub>2</sub>, and NO<sub>2</sub>
  - [b] the temperature or humidity exceeds those recommended by ROHM
  - [c] the Products are exposed to direct sunshine or condensation
  - [d] the Products are exposed to high Electrostatic
2. Even under ROHM recommended storage condition, solderability of products out of recommended storage time period may be degraded. It is strongly recommended to confirm solderability before using Products of which storage time is exceeding the recommended storage time period.
3. Store / transport cartons in the correct direction, which is indicated on a carton with a symbol. Otherwise bent leads may occur due to excessive stress applied when dropping of a carton.
4. Use Products within the specified time after opening a humidity barrier bag. Baking is required before using Products of which storage time is exceeding the recommended storage time period.

### Precaution for Product Label

A two-dimensional barcode printed on ROHM Products label is for ROHM's internal use only.

### Precaution for Disposition

When disposing Products please dispose them properly using an authorized industry waste company.

### Precaution for Foreign Exchange and Foreign Trade act

Since concerned goods might be fallen under listed items of export control prescribed by Foreign exchange and Foreign trade act, please consult with ROHM in case of export.

### Precaution Regarding Intellectual Property Rights

1. All information and data including but not limited to application example contained in this document is for reference only. ROHM does not warrant that foregoing information or data will not infringe any intellectual property rights or any other rights of any third party regarding such information or data.
2. ROHM shall not have any obligations where the claims, actions or demands arising from the combination of the Products with other articles such as components, circuits, systems or external equipment (including software).
3. No license, expressly or implied, is granted hereby under any intellectual property rights or other rights of ROHM or any third parties with respect to the Products or the information contained in this document. Provided, however, that ROHM will not assert its intellectual property rights or other rights against you or your customers to the extent necessary to manufacture or sell products containing the Products, subject to the terms and conditions herein.

### Other Precaution



1. This document may not be reprinted or reproduced, in whole or in part, without prior written consent of ROHM.
2. The Products may not be disassembled, converted, modified, reproduced or otherwise changed without prior written consent of ROHM.
3. In no event shall you use in any way whatsoever the Products and the related technical information contained in the Products or this document for any military purposes, including but not limited to, the development of mass-destruction weapons.
4. The proper names of companies or products described in this document are trademarks or registered trademarks of ROHM, its affiliated companies or third parties.

**General Precaution**







1. Before you use our Products, you are requested to carefully read this document and fully understand its contents. ROHM shall not be in any way responsible or liable for failure, malfunction or accident arising from the use of any ROHM's Products against warning, caution or note contained in this document.
2. All information contained in this document is current as of the issuing date and subject to change without any prior notice. Before purchasing or using ROHM's Products, please confirm the latest information with a ROHM sales representative.
3. The information contained in this document is provided on an "as is" basis and ROHM does not warrant that all information contained in this document is accurate and/or error-free. ROHM shall not be in any way responsible or liable for any damages, expenses or losses incurred by you or third parties resulting from inaccuracy or errors of or concerning such information.

## Looking for pricing, stock, or lifecycle information?

Click below to explore more details on WIN SOURCE:

-  [View BD81A74EFV-ME2 on WIN SOURCE](#)
-  [Rohm Semiconductor](#) Information

## Optimize Your Supply Chain with WIN SOURCE Solutions

-  Global Sourcing Solution
-  Obsolete Management
-  Cost Control Management
-  Shortage Management
-  Alternative Solution
-  Excess Inventory Management