



**THE DATASHEET OF
ATS19580LSNBTN-FSNHPO-A**



Large Air Gap, GMR Transmission Speed and Direction Sensor IC for Gear Tooth Sensing

FEATURES AND BENEFITS

- Fully integrated solution has GMR IC, protection capacitor, and back-bias magnet in a single in-line overmolded package
- Innovative GMR technology provides large operational air gap sensing on ferromagnetic targets
- Advanced algorithms for flexible design-in and system compensation
 - Advanced vibration algorithms guarantee valid direction information
 - Automatically adapts to extreme mechanical changes (air gap) and thermal drifts
- Measures differentially to reject common-mode stray magnetic fields
- Orientation compatible with Hall-effect technology
- Integrated ASIL diagnostics and certified safety design process (optional fault reporting)



PACKAGE: 3-pin SIP (suffix SN)



Not to scale

DESCRIPTION

The ATS19580 is a giant magnetoresistance (GMR) integrated circuit (IC) that provides a user-friendly two-wire solution for applications where speed and direction information is required using ferromagnetic gear tooth targets. The fully integrated package includes the GMR IC, a protection capacitor for EMC robustness, and a back-bias magnet in a single in-line package.

The GMR-based IC is designed for use with ferromagnetic gear tooth targets and is orientation-compatible with Hall-effect technology. The fully integrated solution senses at large operating air gaps and over a large air gap range. State-of-the-art GMR technology on a monolithic IC with industry-leading signal processing provides accurate speed and direction information in response to low-level differential magnetic signals. The differential sensing offers inherent rejection of interfering common-mode magnetic fields.

Integrated diagnostics are used to detect an IC failure that would impact output protocol accuracy, providing coverage compatible with ASIL B. Built-in EEPROM scratch memory offers traceability of the device throughout the IC's product lifecycle. ASIL reporting can be enabled or disabled as a product offering depending on the applications' needs.

The ATS19580 is provided in a lead (Pb) free 3-pin SIP package with tin leadframe plating. The SN package includes a GMR IC, a magnet, and capacitor integrated into a single overmold, with an additional molded lead-stabilizing bar for robust shipping and ease of assembly.

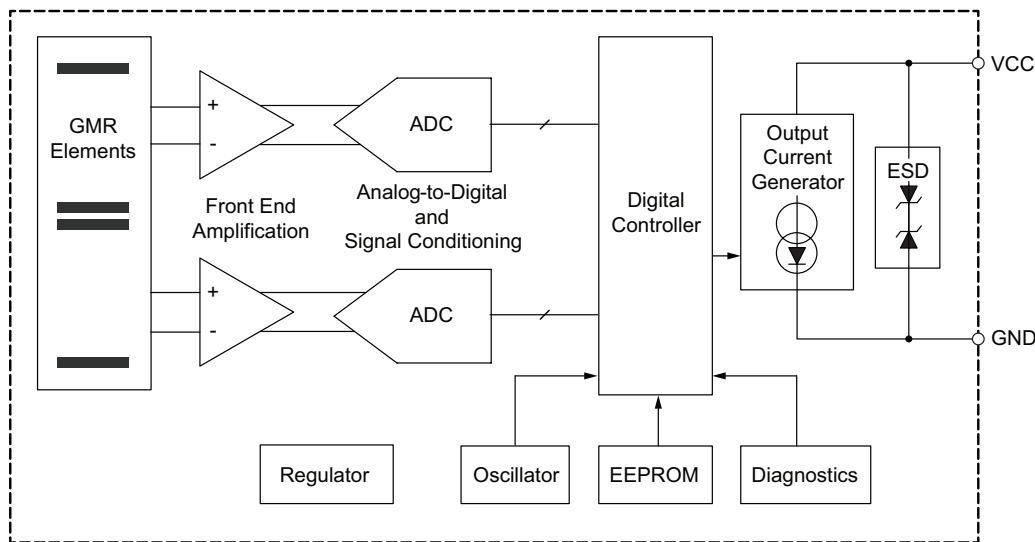

Functional Block Diagram

ATS19580

Large Air Gap, GMR Transmission Speed and Direction Sensor IC for Gear Tooth Sensing

SELECTION GUIDE*

Part Number	Packing	Fault Detection Mode
ATS19580LSNBTN-FSNHPO-A	Tape and reel, 13-in. reel, 800 pieces per reel	Enabled
ATS19580LSNBTN-RSNHPO-A	Tape and reel, 13-in. reel, 800 pieces per reel	Enabled

* Not all combinations are available. Contact Allegro sales for availability and pricing of custom programming options.

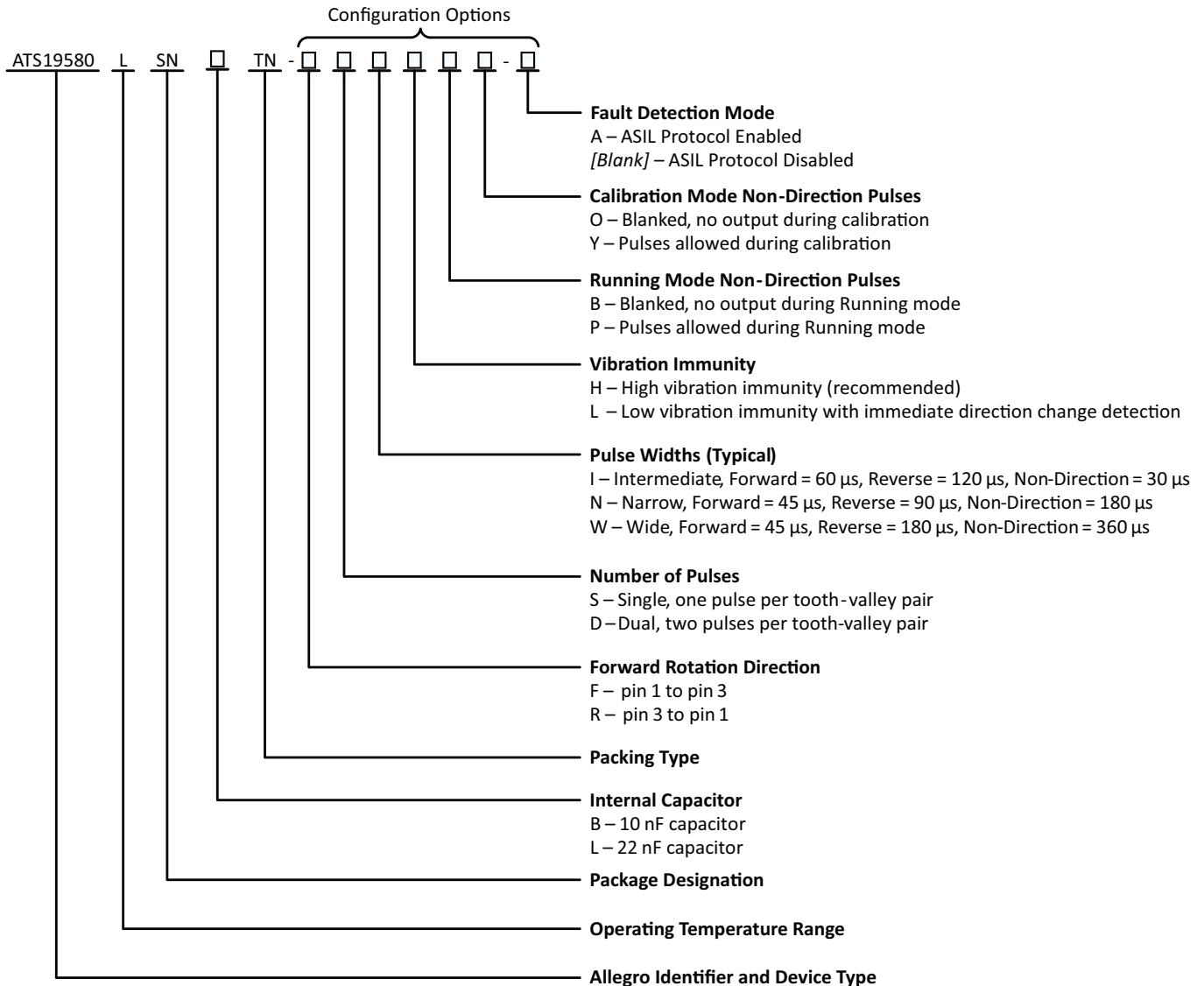

ABSOLUTE MAXIMUM RATINGS

Characteristic	Symbol	Notes	Rating	Units
Supply Voltage	V_{CC}	Refer to Power Derating section	28	V
Reverse Supply Voltage	V_{RCC}		-18	V
Operating Ambient Temperature	T_A	Range L	-40 to 150	°C
Maximum Junction Temperature	$T_{J(max)}$		165	°C
Storage Temperature	T_{stg}		-65 to 170	°C
Externally Applied Magnetic Flux Density	B	In any direction	500	G

PINOUT DIAGRAM AND LIST

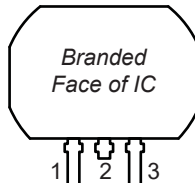

Package SN, 3-Pin SIP Pinout Diagram

Pinout List

Number	Name	Function
1	VCC	Supply Voltage
2	VCC	Supply Voltage
3	GND	Ground

Internal Components

Characteristic	Symbol	Notes	Rating	Units	
Nominal Capacitance	C_{SUPPLY}	Connected between VCC and GND; refer to Figure 1	B	10	nF
			L	22	nF

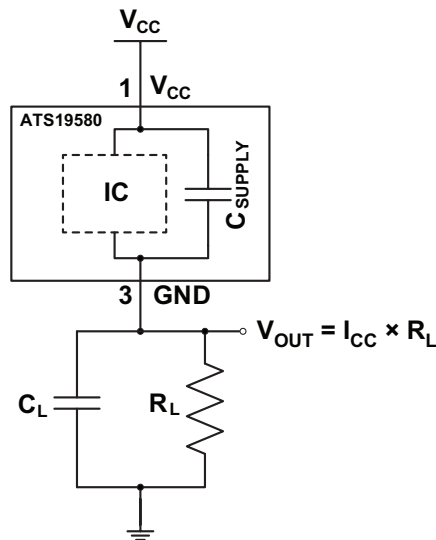

Figure 1: Typical Application Circuit

OPERATING CHARACTERISTICS: Valid throughout full operating and temperature ranges, unless otherwise specified

Characteristic	Symbol	Test Conditions	Min.	Typ. [1]	Max.	Unit	
ELECTRICAL SUPPLY CHARACTERISTICS							
Supply Voltage [2]	V_{CC}	Voltage across pin 1 and pin 3; does not include voltage across R_L	4	–	24	V	
Undervoltage Lockout	$V_{CC(UV)}$		–	–	3.95	V	
Reverse Supply Current [3]	I_{RCC}	$V_{CC} = -18$ V	-10	–	–	mA	
Supply Current	$I_{CC(LOW)}$	Low-current state	5.9	–	8	mA	
	$I_{CC(HIGH)}$	High-current state	12	–	16	mA	
Supply Current Ratio	$I_{CC(HIGH)} / I_{CC(LOW)}$	Ratio of high current to low current (isothermal)	1.9	–	–	–	
ASIL Safety Current	I_{FAULT}	$V_{CC} \leq 14$ V, -A (ASIL) variant	1.5	–	3.9	mA	
ELECTRICAL PROTECTION CHARACTERISTICS							
Supply Zener Clamp Voltage	$V_{Zsupply}$	$I_{CC} = 19$ mA	28	–	–	V	
Reverse Supply Zener Clamp Voltage	$V_{RZSUPPLY}$	$I_{CC} = -3$ mA	–	–	-18	V	
POWER-ON STATE CHARACTERISTICS							
Power-On State	POS	$V_{CC} > V_{CC(min)}$	$I_{CC(LOW)}$			–	
Power-On Time [4]	t_{PO}	Time from $V_{CC} > V_{CC(min)}$, until device has entered Calibration mode	–	–	1	ms	
OUTPUT CHARACTERISTICS							
Output Rise Time	t_r	Voltage measured at pin 3 (see Figure 1), $R_L = 100 \Omega$, $C_L = 10$ pF, measured between 10% and 90% of signal	Capacitor L variant	0	4.5	8.8	μ s
			Capacitor B variant	0	2	4	μ s
Output Fall Time	t_f	Voltage measured at pin 3 (see Figure 1), $R_L = 100 \Omega$, $C_L = 10$ pF, measured between 10% and 90% of signal	Capacitor L variant	0	4.5	8.8	μ s
			Capacitor B variant	0	2	4	μ s
Pulse Width, Fault	$t_{w(FAULT)}$	$R_L = 100 \Omega$, $C_L = 10$ pF, pulse duration measured at threshold of $(I_{CC(LOW)} + I_{FAULT}) / 2$	-A (ASIL) variant	4	–	8	ms

Continued on next page...

OPERATING CHARACTERISTICS (continued): Valid throughout full operating and temperature ranges, unless otherwise specified

Characteristic	Symbol	Test Conditions	Min.	Typ. [1]	Max.	Unit
NARROW PULSE WIDTH OPTION (-xSNxxx variants) [5]						
Pulse Width, Forward Rotation	$t_{W(FWD)}$		38	45	52	μs
Pulse Width, Reverse Rotation	$t_{W(REV)}$		76	90	104	μs
Pulse Width, Non-Direction	$t_{W(ND)}$		153	180	207	μs
Operating Frequency, Forward Rotation	f_{FWD}		0	–	12	kHz
Operating Frequency, Reverse Rotation [6]	f_{REV}		0	–	7	kHz
Operating Frequency, Non-Direction Pulses [6]	f_{ND}		0	–	4	kHz
WIDE PULSE WIDTH OPTION (-xSWxxx variants) [5]						
Pulse Width, Forward Rotation	$t_{W(FWD)}$		38	45	52	μs
Pulse Width, Reverse Rotation	$t_{W(REV)}$		153	180	207	μs
Pulse Width, Non-Direction	$t_{W(ND)}$		306	360	414	μs
Operating Frequency, Forward Rotation	f_{FWD}		0	–	12	kHz
Operating Frequency, Reverse Rotation [6]	f_{REV}		0	–	4	kHz
Operating Frequency, Non-Direction Pulses [6]	f_{ND}		0	–	2.2	kHz
INTERMEDIATE PULSE WIDTH OPTION (-xS1xxx variants) [5][7]						
Threshold to Enter High-Speed Mode	f_{HIGH}	Increasing T_{CYCLE} frequency	0.935	1.1	1.265	kHz
Threshold to Exit High-Speed Mode	f_{LOW}	Decreasing T_{CYCLE} frequency	0.85	1	1.15	kHz
Pulse Pre-Low Length	$t_{W(PRE)}$		25	30	35	μs
Pulse Width, Forward Rotation	$t_{W(FWD)}$	T_{CYCLE} frequency < f_{LOW}	51	60	69	μs
Pulse Width, Reverse Rotation	$t_{W(REV)}$	T_{CYCLE} frequency < f_{LOW}	102	120	138	μs
Pulse Width, Non-Direction	$t_{W(ND)}$		25	30	35	μs
Pulse Width, High Speed	$t_{W(HS)}$	T_{CYCLE} frequency > f_{HIGH}	25	30	35	μs
Operating Frequency, Forward Rotation	f_{FWD}	Direction information is not available when frequency > f_{HIGH}	0	–	12	kHz
Operating Frequency, Reverse Rotation	f_{REV}	Direction information is not available when frequency > f_{HIGH}	0	–	12	kHz
Operating Frequency, Non-Direction Pulses	f_{ND}	Direction information is not available when frequency > f_{HIGH}	0	–	12	kHz

Continued on next page...

OPERATING CHARACTERISTICS (continued): Valid throughout full operating and temperature ranges, unless otherwise specified

Characteristic	Symbol	Test Conditions	Min.	Typ. [1]	Max.	Unit
Operational Air Gap Range [8]	AG	Using Reference Target 60-0, tested at 1000 rpm	1.5	–	4.5	mm
Operate Point	B _{OP}	Percentage of IC processed magnetic signals; see Figure 3	–	70	–	%
Release Point	B _{RP}	Percentage of IC processed magnetic signals; see Figure 3	–	30	–	%
PERFORMANCE CHARACTERISTICS						
Initial Calibration	T _{CAL}	Amount of target rotation (constant direction) after t _{PO} to first valid speed and direction output; see Figure 2	–	3	4	T _{CYCLE}
Vibration Immunity (Startup)		Refer to Functional Description section	1	–	–	T _{CYCLE}
Vibration Immunity (Running Mode)		Refer to Functional Description section	1	–	–	T _{CYCLE}
Tooth-to-Tooth Variation over 1 T _{CYCLE}		Using Reference Target 60-0 [9], correct output sequence	–	0.25	–	mm
Total Air Gap Variation During Operation		Momentary interruptions in output sequence permitted; operation within AG range	–3	–	3	mm
THERMAL CHARACTERISTICS						
Package Thermal Resistance [10]	R _{θJA}	Single-layer PCB with copper limited to solder pads	–	150	–	°C/W

[1] Typical values are at V_{CC} = 5 V and T_A = 25°C, unless otherwise specified. Performance may vary for individual units, within the maximum and minimum limits.

[2] Maximum voltage must be adjusted for power dissipation and junction temperature; see Power Derating section.

[3] Negative current is defined as conventional current coming out of (sourced from) the specified device terminal.

[4] Output transients prior to t_{PO} should be ignored.

[5] R_L = 100 Ω and C_L = 10 pF. Pulse duration measured at threshold of (I_{CC(HIGH)} + I_{CC(LOW)}) / 2.

[6] Maximum Operating Frequency is determined by satisfactory separation of output pulses. If shorter low-state durations can be resolved, the maximum f_{REV} and f_{ND} may be higher.

[7] Direction information is not available in High-Speed mode with Intermediate Pulse Width variant.

[8] Operating air gap is dependent on the available magnetic field. The available field is target geometry and material dependent and should be independently characterized.

[9] To determine IC's tolerance to air gap variations on other targets, the complete magnetic system must be analyzed. Due to the nature of the GMR system, contact Allegro for assistance in assessing other targets for use with ATS19580.

[10] Additional thermal information is available on the Allegro website.

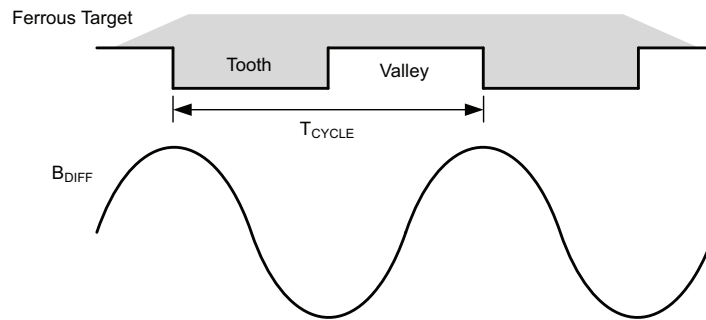

T_{CYCLE} = Target Cycle; the amount of rotation that moves one tooth and valley across the sensor.

B_{DIFF} = The differential magnetic flux density sensed by the sensor.

Figure 2: Definition of T_{CYCLE}

REFERENCE TARGET 60-0 (60-TOOTH TARGET)

Characteristics	Symbol	Test Conditions	Typ.	Units	Symbol Key
Outside Diameter	D_o	Outside diameter of target	120	mm	
Face Width	F	Breadth of tooth, with respect to branded face	6	mm	
Circular Tooth Length	t	Length of tooth, with respect to branded face	3	degrees	
Circular Valley Width	t_v	Length of valley, with respect to branded face	3	degrees	
Tooth Whole Depth	h_t		3	mm	
Material		Low Carbon Steel	-	-	

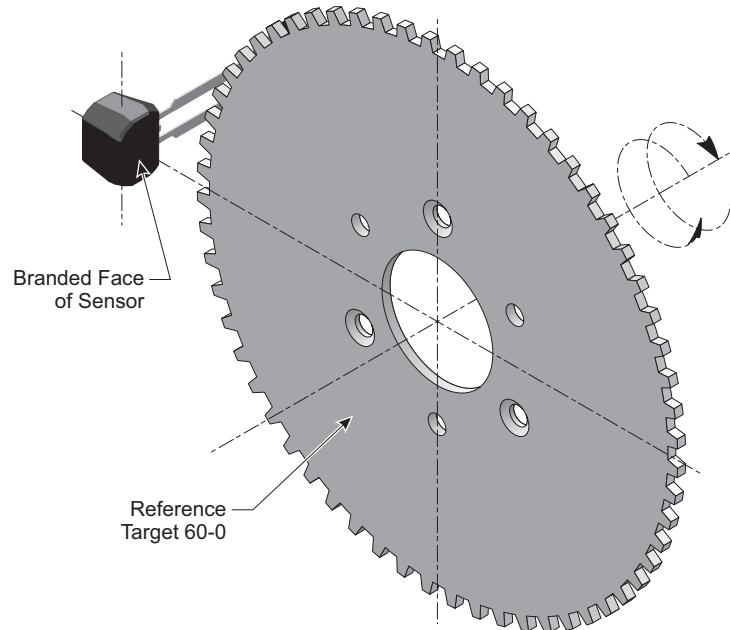

CHARACTERISTIC PLOTS

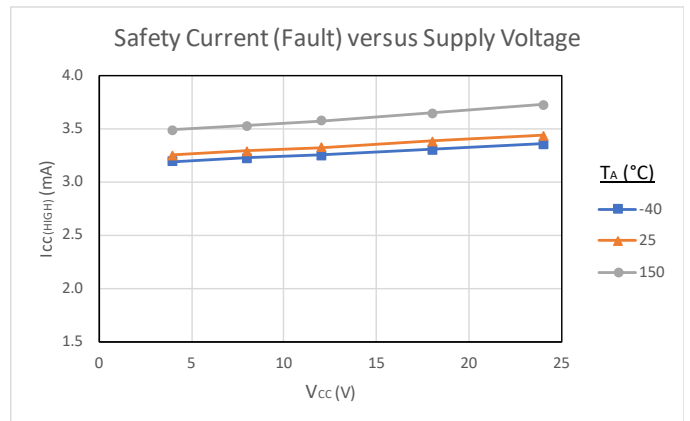
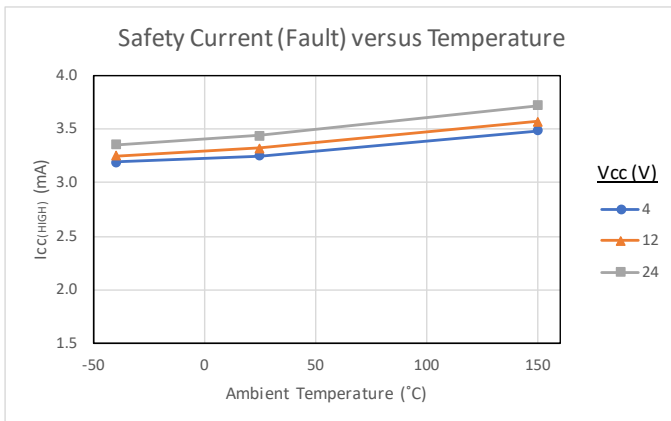
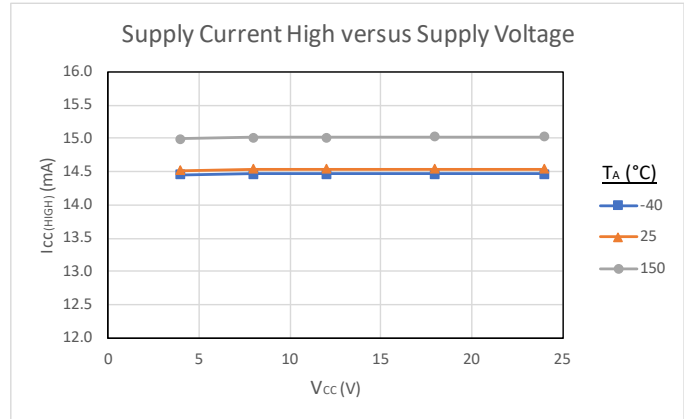
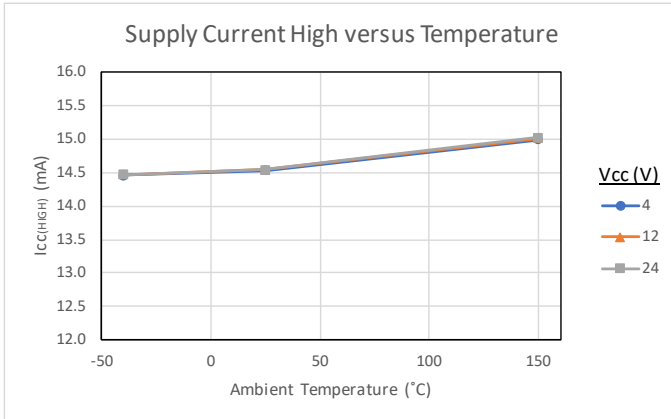
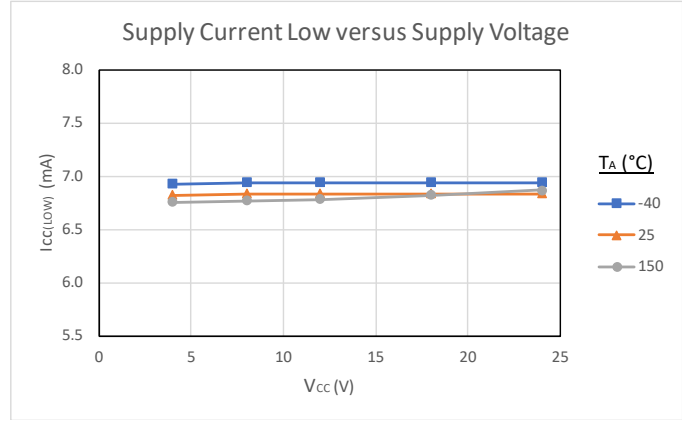
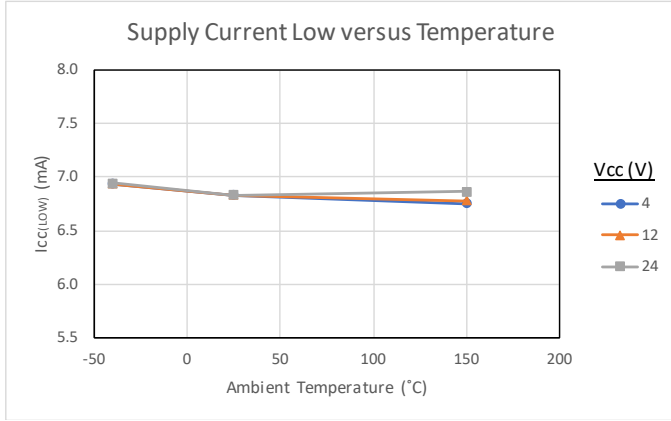

CHARACTERISTIC PLOTS (continued)

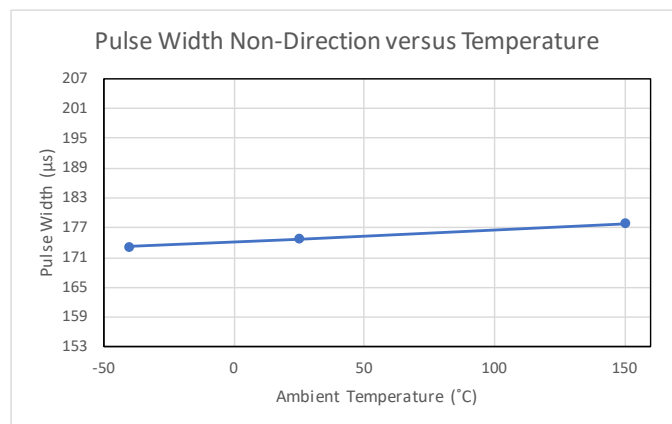
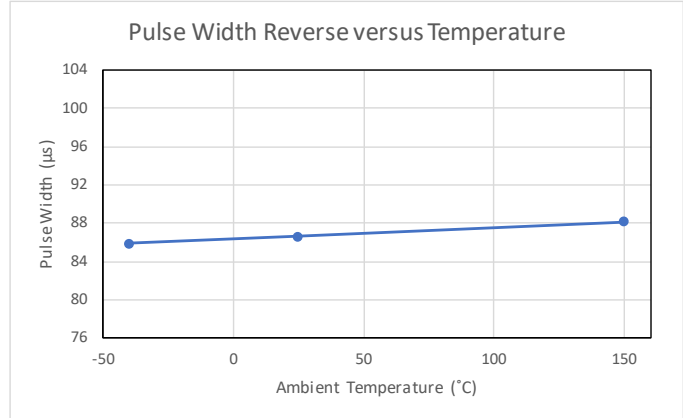
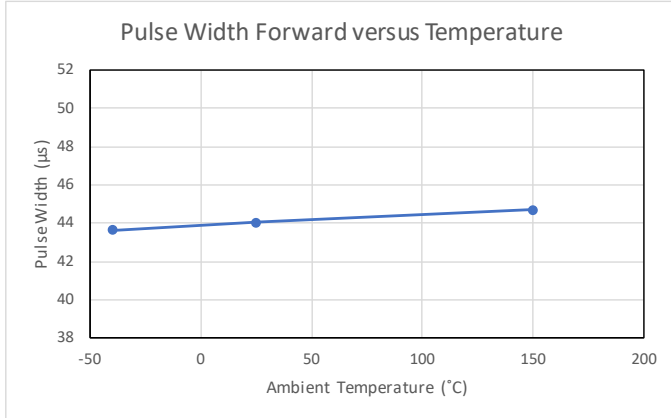

FUNCTIONAL DESCRIPTION

Sensing Technology

The sensor IC contains on-chip GMR elements that are used to detect magnetic signals created by an adjacent target. These transducers provide electrical signals containing information regarding edge position and direction of target rotation. The ATS19580 is intended for use with ferromagnetic targets.

After proper power is applied to the sensor IC, it is capable of providing digital information that is representative of the features of a rotating target. The waveform diagrams in Figure 3 present the automatic translation of the target profiles, through their induced magnetic profiles, to the digital output signal of the sensor IC.

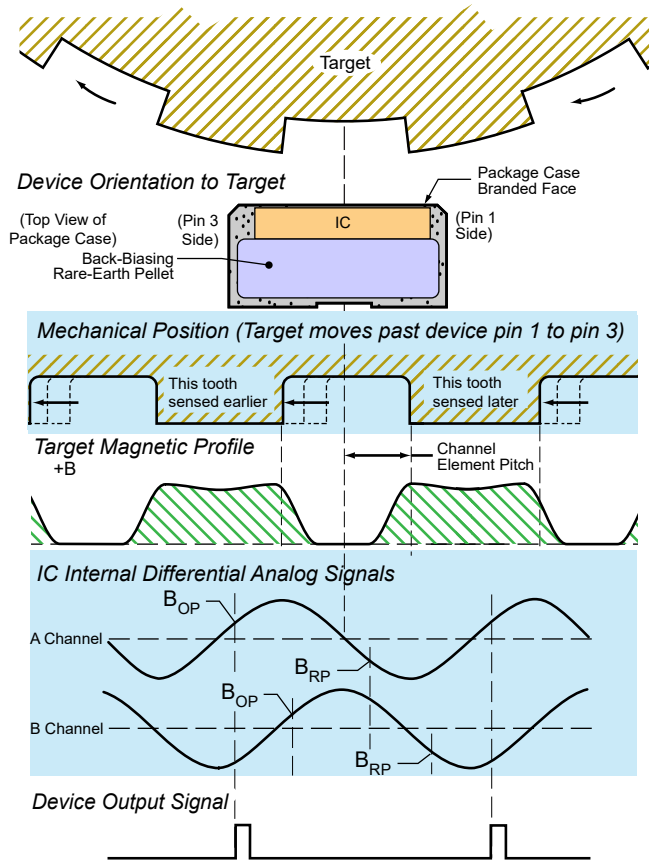

Figure 3: Magnetic Profile

Data Protocol Description

When a target passes in front of the device (opposite the branded face of the package case), the ATS19580 “S” variant generates an output pulse for each tooth-valley pair of the target. Speed information is provided by the output pulse rate, while direction of target rotation is provided by the duration of the output pulse. The sensor IC can sense target movement in both the forward and reverse direction.

VARIANTS

Figure 4 shows forward and reverse rotation for the “F” variant of the sensor IC, where forward is defined as target motion from pin 1 to 3. The sensor IC can also be factory-programmed for the opposite definition (“R” variant), where forward is defined as target motion from pin 3 to 1.

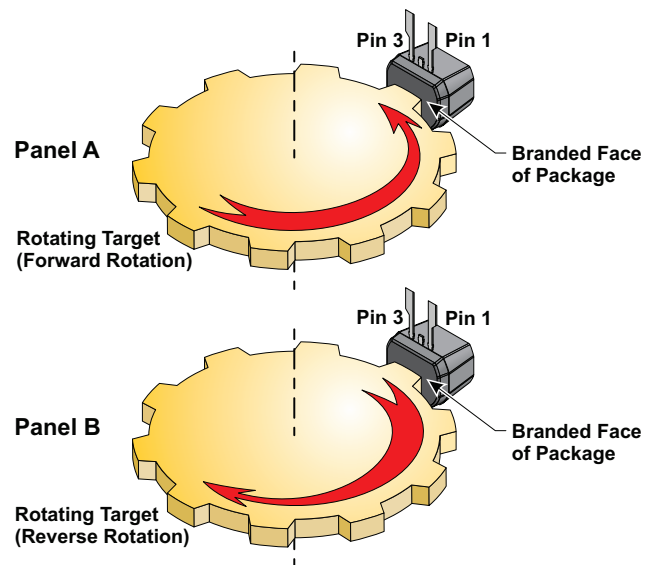

Figure 4: Target Rotation (“F” Variant Shown)

Target Design

The ATS19580 is designed to work with a variety of target shapes and sizes in addition to the Reference Target 60-0 in this data-sheet. To determine the operating air gap range for each target, as well as the suitability for proper direction and vibration detection, the magnetic profile of each must be analyzed.

Power-On (Calibration)

After power is applied to the sensor IC, the IC internally detects the magnetic profile of the target. Operation begins with a calibration period, during which the sensor IC does not provide direction information; direction pulses are provided once constant direction of rotation is determined. Depending on the selected variant, non-directional pulses ($t_{W(ND)}$) may or may not be provided during calibration.

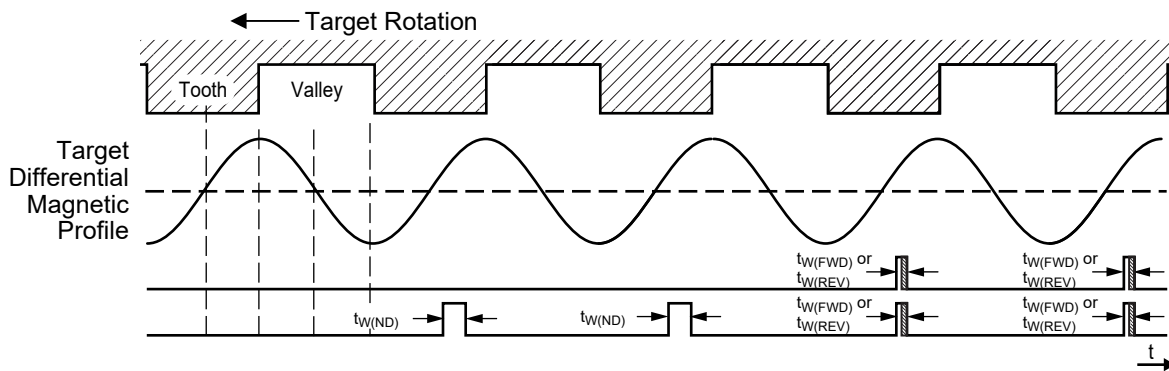

Figure 5: Output options after power-on

Vibration

The IC has vibration detection ability, where vibration is defined as multiple changes in target direction within the vibration immunity specification. Two vibration output protocols are available,

where the first change in direction may be provided to the output or may be suppressed. Options are also available such that non-direction pulses may be provided during the vibration event until constant target rotation is validated.

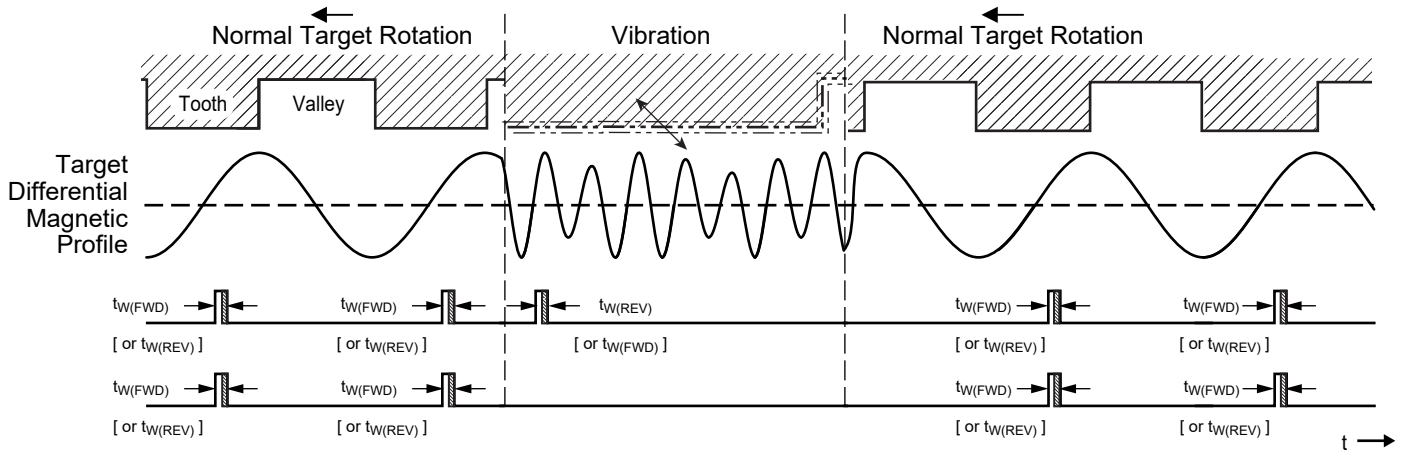

Figure 6: Vibration output protocol options

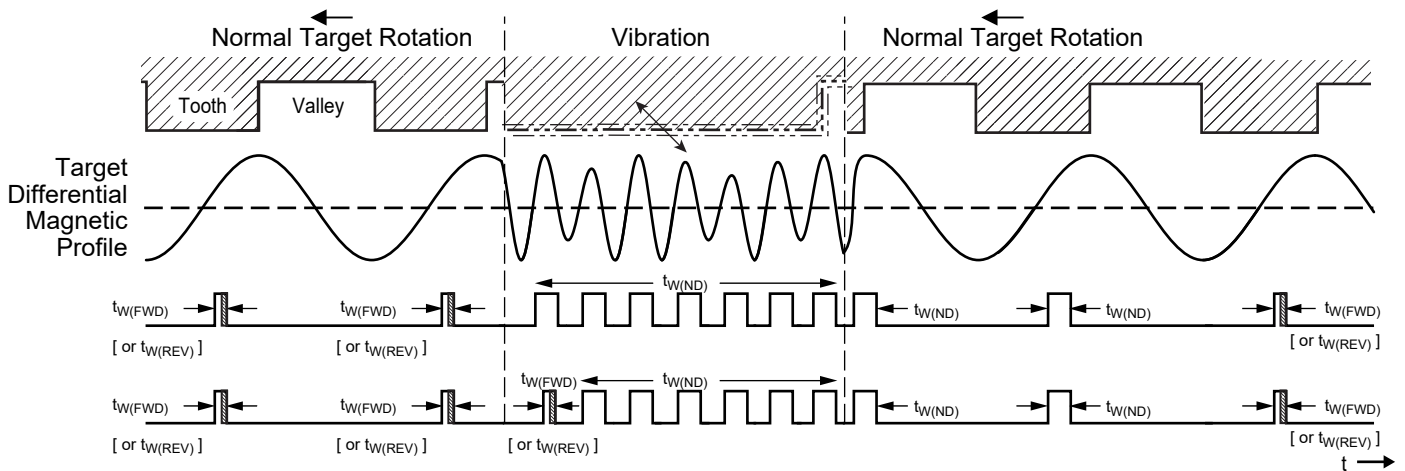

Figure 7: Output protocol options with non-direction pulses

ASIL Safe State

The A19580 sensor IC contains diagnostic circuitry that will continuously monitor occurrences of failure defects within the IC. Refer to Figure 8 for the output protocol of the ASIL Safe.

Refer to the ATS19580 Safety Manual for additional details.

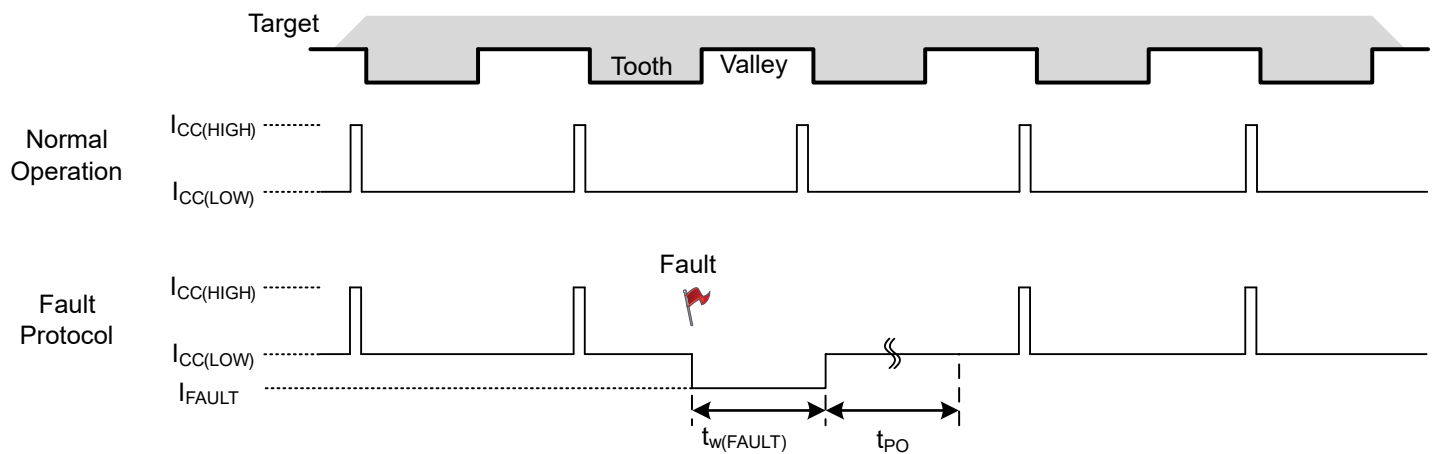

Figure 8: Output Protocol (ASIL Safe State)

POWER DERATING

The device must be operated below the maximum junction temperature of the device ($T_{J(max)}$). Under certain combinations of peak conditions, reliable operation may require derating supplied power or improving the heat dissipation properties of the application. This section presents a procedure for correlating factors affecting operating T_J . (Thermal data is also available on the Allegro website.)

The Package Thermal Resistance ($R_{\theta JA}$) is a figure of merit summarizing the ability of the application and the device to dissipate heat from the junction (die), through all paths to the ambient air. Its primary component is the Effective Thermal Conductivity (K) of the printed circuit board, including adjacent devices and traces. Radiation from the die through the device case ($R_{\theta JC}$) is relatively small component of $R_{\theta JA}$. Ambient air temperature (T_A) and air motion are significant external factors, damped by overmolding.

The effect of varying power levels (Power Dissipation, P_D), can be estimated. The following formulas represent the fundamental relationships used to estimate T_J , at P_D .

$$P_D = V_{IN} \times I_{IN} \quad (1)$$

$$\Delta T = P_D \times R_{\theta JA} \quad (2)$$

$$T_J = T_A + \Delta T \quad (3)$$

For example, given common conditions such as: $T_A = 25^\circ C$, $V_{CC} = 12 V$, $I_{CC} = 7.0 mA$, and $R_{\theta JA} = 150^\circ C/W$, then:

$$P_D = V_{CC} \times I_{CC} = 12 V \times 7.0 mA = 84 mW$$

$$\Delta T = P_D \times R_{\theta JA} = 84 mW \times 150^\circ C/W = 12.6^\circ C$$

$$T_J = T_A + \Delta T = 25^\circ C + 12.6^\circ C = 37.6^\circ C$$

A worst-case estimate, $P_{D(max)}$, represents the maximum allowable power level ($V_{CC(max)}$, $I_{CC(max)}$), without exceeding $T_{J(max)}$, at a selected $R_{\theta JA}$ and T_A

Example: Reliability for V_{CC} at $T_A = 150^\circ C$, package SN, using a single-layer PCB.

Observe the worst-case ratings for the device, specifically: $R_{\theta JA} = 150^\circ C/W$, $T_{J(max)} = 165^\circ C$, $V_{CC(max)} = 24 V$, and $I_{CC(avg)} = 14.6 mA$. $I_{CC(avg)}$ is computed using $I_{CC(LOW)(max)}$ and $I_{CC(HIGH)(max)}$, with a duty cycle of 83% computed from $t_{w(REV)(max)}$ on-time at 4 kHz maximum operating frequency.

Calculate the maximum allowable power level, $P_{D(max)}$. First, invert equation 3:

$$\Delta T_{max} = T_{J(max)} - T_A = 165^\circ C - 150^\circ C = 15^\circ C$$

This provides the allowable increase to T_J resulting from internal power dissipation. Then, invert equation 2:

$$P_{D(max)} = \Delta T_{max} \div R_{\theta JA} = 15^\circ C \div 150^\circ C/W = 100 mW$$

Finally, invert equation 1 with respect to voltage:

$$V_{CC(est)} = P_{D(max)} \div I_{CC(avg)} = 100 mW \div 14.6 mA = 6.8 V$$

The result indicates that, at T_A , the application and device cannot dissipate adequate amounts of heat at operating voltages above 6.8 V at $150^\circ C$.

Compare $V_{CC(est)}$ to $V_{CC(max)}$. If $V_{CC(est)} \leq V_{CC(max)}$, then reliable operation between $V_{CC(est)}$ and $V_{CC(max)}$ requires enhanced $R_{\theta JA}$. If $V_{CC(est)} \geq V_{CC(max)}$, then operation between $V_{CC(est)}$ and $V_{CC(max)}$ is reliable under these conditions.

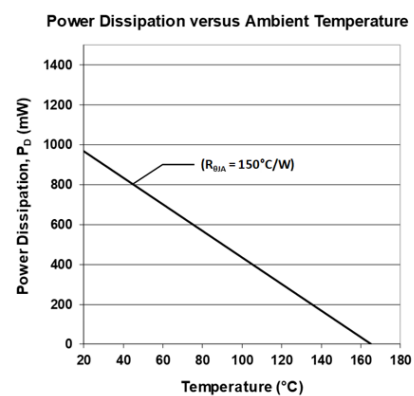
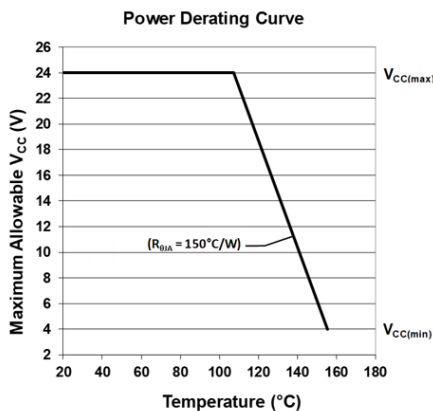

PACKAGE OUTLINE DRAWING

For Reference Only – Not for Tooling Use

(Reference Allegro DWG-0000429, Rev. 5)

Dimensions in millimeters – NOT TO SCALE

Dimensions exclusive of mold flash, gate burs, and dambar protrusions
Exact case and lead configuration at supplier discretion within limits shown

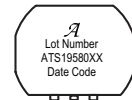
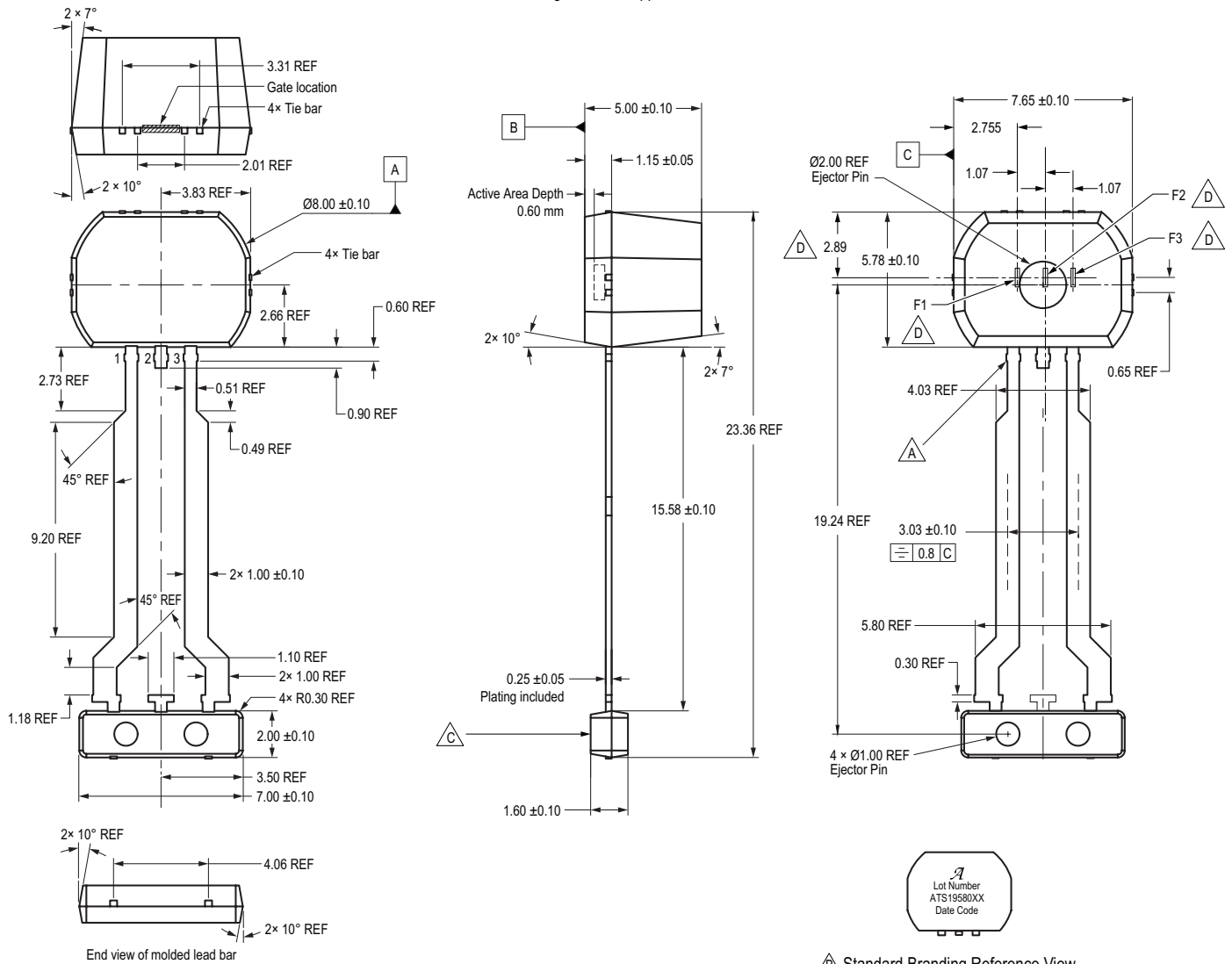

Standard Branding Reference View

Lines 1, 2, 3, 4: Max. 10 characters per line

Line 1: Logo A
Line 2: Characters 5, 6, 7, 8, 9, 10, 11 of Assembly Lot Number
Line 3: 3-character Prefix (ATS), 5-digit Part Number (19580), 0-2 character Package Variant (XX).
Line 4: 4-digit Date Code

- Dambar removal protrusion (24x)
- Branding scale and appearance at supplier discretion
- Molded lead bar for preventing damage to leads during shipment
- GMR elements (F1, F2, F3); not to scale

Figure 9: Package SN, 3-Pin SIP

Revision History

Number	Date	Description
–	February 12, 2020	Advance information release
1	July 24, 2020	Updated Externally Applied Magnetic Flux Density (p. 2), ASIL Safety Current test conditions (p. 4); added Pulse Pre-Low Length characteristic (p. 5); updated Performance Characteristics (p. 6); added Characteristic Plots (p. 8-9); updated Target Design section (p. 11), Figure 8 (p. 13), and Active Area Depth (p. 15).
2	November 18, 2020	Updated status from advance to final release; updated Selection Guide (page 2), Initial Calibration and Tooth-to-Tooth Variation over 1 T _{CYCLE} values (page 6)
3	February 16, 2021	Removed “(pending assessment)” from page 1, due to approved status (effective Jan 2021).
4	March 9, 2022	Updated package drawing (page 15)

Copyright 2022, Allegro MicroSystems.

Allegro MicroSystems reserves the right to make, from time to time, such departures from the detail specifications as may be required to permit improvements in the performance, reliability, or manufacturability of its products. Before placing an order, the user is cautioned to verify that the information being relied upon is current.

Allegro's products are not to be used in any devices or systems, including but not limited to life support devices or systems, in which a failure of Allegro's product can reasonably be expected to cause bodily harm.

The information included herein is believed to be accurate and reliable. However, Allegro MicroSystems assumes no responsibility for its use; nor for any infringement of patents or other rights of third parties which may result from its use.

Copies of this document are considered uncontrolled documents.

For the latest version of this document, visit our website:

www.allegromicro.com

Looking for pricing, stock, or lifecycle information?

Click below to explore more details on WIN SOURCE:

- ⊖ [View AT519580LSNBTN-FSNHPO-A on WIN SOURCE](#)
- ⊖ [Allegro MicroSystems, LLC Information](#)

Optimize Your Supply Chain with WIN SOURCE Solutions

- ✓ Global Sourcing Solution
- ✓ Obsolete Management
- ✓ Cost Control Management
- ✓ Shortage Management
- ✓ Alternative Solution
- ✓ Excess Inventory Management