



**THE DATASHEET OF
ARS19510LUBBTN-RSWPHUJ**



Two-Wire, Differential, Vibration-Resistant Sensor IC with Speed and Direction Output

FEATURES AND BENEFITS

- EMC compliance using integrated protection components and advanced IC design methodology
 - Immunity to harsh automotive transients such as switching inductive loads
- Advanced algorithm options capable of withstanding full range sudden and dynamic air gap shifts
- Two-wire, pulse-width output protocol
- Highly configurable output protocol options
- Speed and direction information of target
- Vibration tolerance
 - Small signal lockout for small amplitude vibration
 - Proprietary vibration detection algorithms for large amplitude vibration
- Air-gap-independent switch points
- Undervoltage lockout
- True zero-speed operation
- Wide operating voltage range
- Single chip sensing IC for high reliability
- Robust test-coverage capability with Scan Path and IDDQ measurement
- Integrated back-biasing magnet

PACKAGE: 2-pin SIP (suffix UB)



Not to scale

DESCRIPTION

The ARS19510LUB integrates an advanced Hall-effect circuit IC and EMC protection components in a single overmolded package. The optimized, user-friendly solution provides direction detection and true zero-speed digital gear-tooth sensing for challenging environments, such as automotive and industrial transmissions and a wide variety of gear-tooth-sensing applications.

The IC's patented advanced algorithms provide EMI compliance to the harshest automotive requirements, capability to withstand full range sudden and dynamic air gap shifts, and vibration suppression.

The speed and direction of the target are communicated through a variable pulse-width output protocol. The ARS19510 is particularly adept at handling vibration without sacrificing maximum air gap capability or creating any erroneous "direction" pulses. The advanced vibration detection algorithm will systematically calibrate the sensor IC on the initial teeth of true target rotation and not on vibration, ensuring an accurate running mode signal. Advanced packaging combined with innovative algorithms make the ARS19510 an ideal solution for a wide range of speed and direction-sensing needs.

This device is available in a lead (Pb) free 2-pin SIP package with tin-plated leadframe.

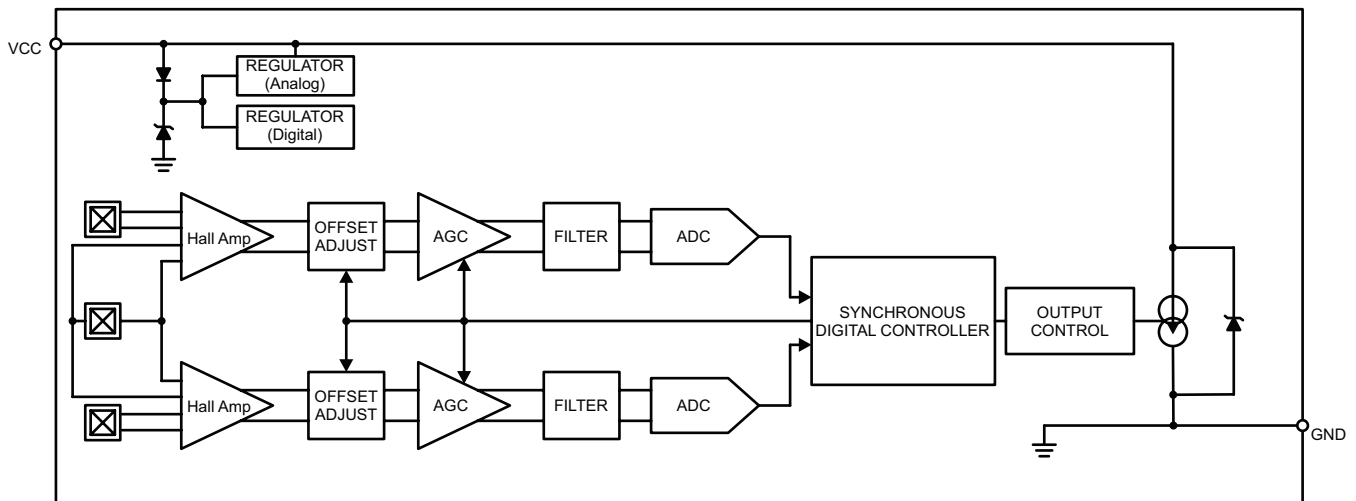

Functional Block Diagram

ARS19510LUB

Two-Wire, Differential, Vibration-Resistant Sensor IC with Speed and Direction Output

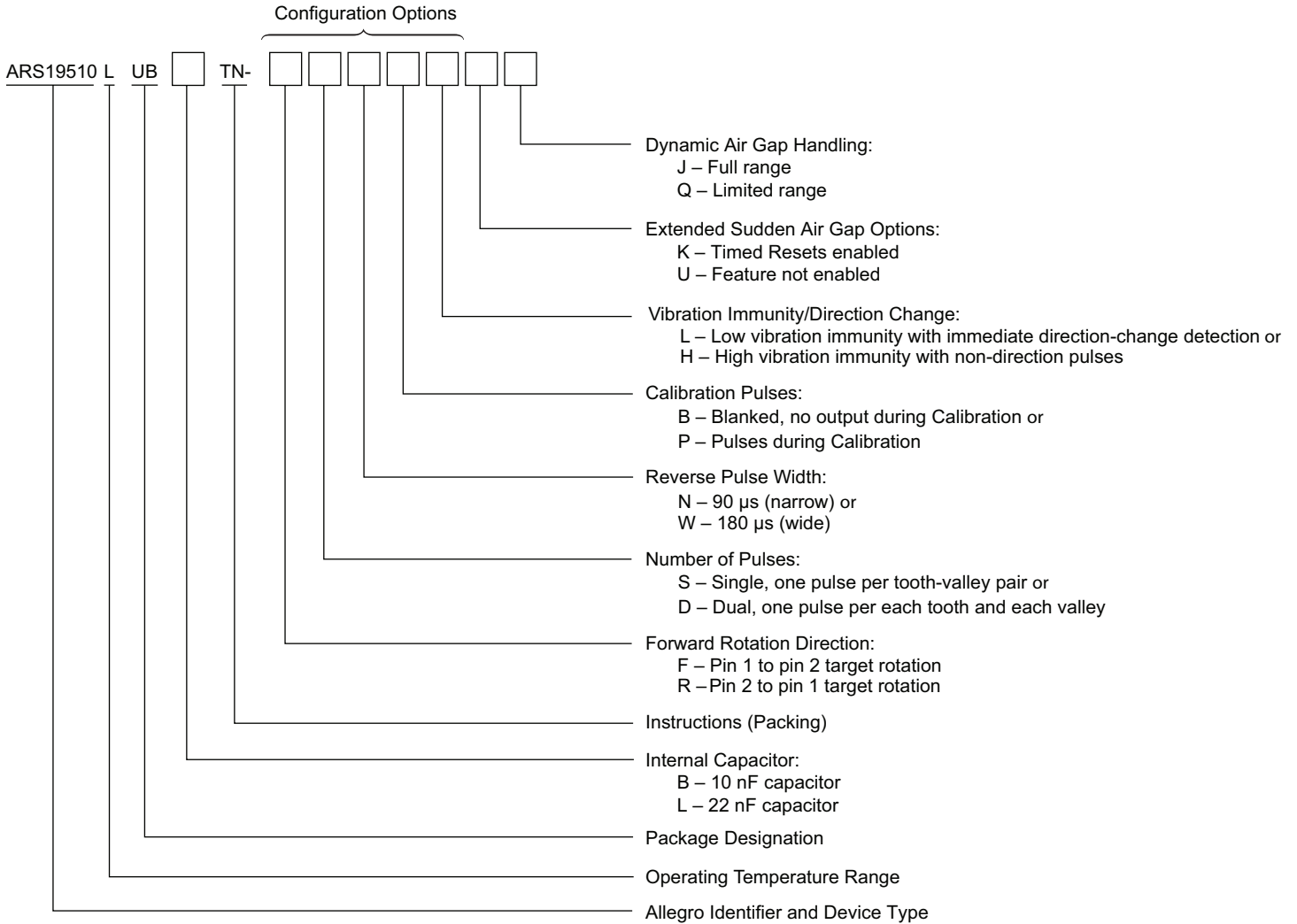

For example: ARS19510LUBBTN-RSNPHKJ

Where a configuration character is unspecified, “x” will be used. For example, -xSNPLKJ applies to both Rotation Direction configuration variants.

SELECTION GUIDE*

| Part Number | Packing |
|------------------------|--|
| ARS19510LUBBTN-RSWPHUJ | Tape and reel, 13-in. reel, 4000 pieces per reel |
| ARS19510LUBBTN-FSWPHUJ | Tape and reel, 13-in. reel, 4000 pieces per reel |

* Not all combinations are available. Contact Allegro sales for availability and pricing of custom programming options.

SPECIFICATIONS

ABSOLUTE MAXIMUM RATINGS

| Characteristic | Symbol | Notes | Rating | Units |
|-------------------------------|--------------|---------------------------------|------------|-------|
| Supply Voltage | V_{CC} | Refer to Power Derating section | 28 | V |
| Reverse Supply Voltage | V_{RCC} | | -18 | V |
| Operating Ambient Temperature | T_A | Range L | -40 to 150 | °C |
| Maximum Junction Temperature | $T_{J(max)}$ | | 165 | °C |
| Storage Temperature | T_{stg} | | -60 to 170 | °C |

Internal Discrete Capacitor Ratings

| Characteristic | Symbol | Notes | Rating | Units |
|---------------------|--------------|-------------------------------|--------|----------|
| Nominal Capacitance | C_{SUPPLY} | Connected between VCC and GND | UBB | 10000 pF |
| | | | UBL | 22000 pF |

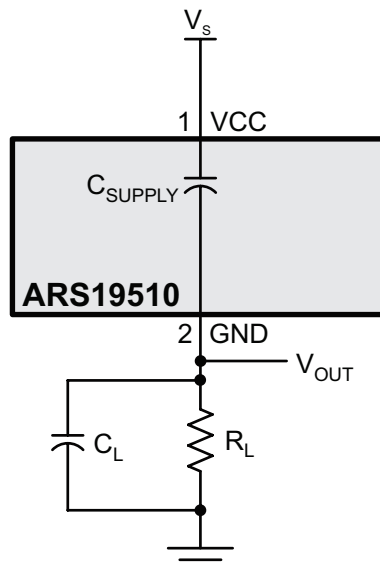
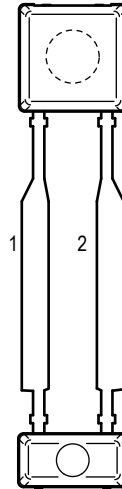

Figure 1: Typical Application Circuit

PINOUT DIAGRAM AND TERMINAL LIST



Package UB, 2-Pin SIP Pinout Diagram

Terminal List Table

| Number | Name | Function |
|--------|------|----------------|
| 1 | VCC | Supply voltage |
| 2 | GND | Ground |

ARS19510LUB

Two-Wire, Differential, Vibration-Resistant Sensor IC with Speed and Direction Output

OPERATING CHARACTERISTICS: Valid throughout full operating and temperature ranges, unless otherwise noted.

| Characteristics | Symbol | Test Conditions | Min. | Typ. [1] | Max. | Unit | |
|--|------------------------------|--|--------------------|----------|------|---------------|---------------|
| ELECTRICAL CHARACTERISTICS | | | | | | | |
| Supply Voltage ^[2] | V_{CC} | Operating, $T_J < T_{J(max)}$ | 4 | – | 24 | V | |
| Undervoltage Lockout | $V_{CC(UV)}$ | $V_{CC} 0 \rightarrow 5 V$ or $5 \rightarrow 0 V$ | – | 3.6 | 3.95 | V | |
| Reverse Supply Current ^[3] | I_{RCC} | $V_{CC} = V_{RCC(MAX)}$ | – | – | –10 | mA | |
| Supply Zener Clamp Voltage | $V_{ZSUPPLY}$ | $I_{CC} = I_{CC(HIGH)} + 3 \text{ mA}$, $T_A = 25^\circ\text{C}$ | 28 | – | – | V | |
| Supply Current | $I_{CC(Low)}$ | Low-current state (Running mode) | 5 | – | 8 | mA | |
| | $I_{CC(High)}$ | High-current state (Running mode) | 12 | – | 16 | mA | |
| | $I_{CC(SU)(Low)}$ | Startup current level and Power-On mode | 5 | – | 8.5 | mA | |
| Supply Current Ratio | $I_{CC(High)} / I_{CC(Low)}$ | Measured as a ratio of high current to low current | 1.9 | – | – | – | |
| OUTPUT STAGE^[4] | | | | | | | |
| Output Rise Time | t_r | $\Delta I/\Delta t$ from 10% to 90% I_{CC} level; corresponds to measured output slew rate with C_{SUPPLY} | UBL package option | 0 | 4.5 | 8 | μs |
| | | | UBB package option | 0 | 2 | 4 | μs |
| Output Fall Time | t_r | $\Delta I/\Delta t$ from 90% to 10% I_{CC} level; corresponds to measured output slew rate with C_{SUPPLY} | UBL package option | 0 | 4.5 | 8 | μs |
| | | | UBB package option | 0 | 2 | 4 | μs |
| OUTPUT PULSE CHARACTERISTICS^[4] | | | | | | | |
| Pulse Width, Forward Rotation | $t_{w(FWD)}$ | | 38 | 45 | 52 | μs | |
| Pulse Width, Reverse Rotation | $t_{w(REV)}$ | -xxNxxxx variant | 76 | 90 | 104 | μs | |
| | | -xxWxxxx variant | 153 | 180 | 207 | μs | |
| Pulse Width, Non-Direction | $t_{w(ND)}$ | -xxNPxxx and -xxNxHxx variants | 153 | 180 | 207 | μs | |
| | | -xxWPxxx and -xxWxHxx variants | 306 | 360 | 414 | μs | |
| PERFORMANCE CHARACTERISTICS | | | | | | | |
| Operate Point | B_{OP} | % of peak-to-peak V_{PROC} | – | 69 | – | % | |
| Release Point | B_{RP} | % of peak-to-peak V_{PROC} | – | 31 | – | % | |
| Operating Frequency, Forward Rotation | f_{FWD} | -xSxxxxx variant | 0 | – | 12 | kHz | |
| | | -xDxxxxx variant | 0 | – | 6 | kHz | |
| Operating Frequency, Reverse Rotation | f_{REV} | -xSNxxxx variant | 0 | – | 7 | kHz | |
| | | -xDNxxxx variant | 0 | – | 3.5 | kHz | |
| | | -xSWxxxx variant | 0 | – | 4 | kHz | |
| | | -xDWxxxx variant | 0 | – | 2 | kHz | |
| Operating Frequency, Non-Direction Pulses ^[5] | f_{ND} | -xSNxxxx variant | 0 | – | 4 | kHz | |
| | | -xDNxxxx variant | 0 | – | 2 | kHz | |
| | | -xSWxxxx variant | 0 | – | 2.2 | kHz | |
| | | -xDWxxxx variant | 0 | – | 1.1 | kHz | |

Continued on the next page...

¹ Typical values are at $T_A = 25^\circ\text{C}$ and $V_{CC} = 12 \text{ V}$. Performance may vary for individual units, within the specified maximum and minimum limits.

² Maximum voltage must be adjusted for power dissipation and junction temperature; see Power Derating section.

³ Negative current is defined as conventional current coming out of (sourced from) the specified device terminal.

⁴ Load circuit is $R_L = 100 \Omega$ and $C_L = 10 \text{ pF}$. Pulse duration measured at threshold of $((I_{CC(HIGH)} + I_{CC(LOW)})/2)$

⁵ Maximum Operating Frequency is determined by satisfactory separation of output pulses: $I_{CC(LOW)}$ of $t_{w(FWD)(MIN)}$. If the customer can resolve shorter low-state durations, maximum f_{REV} and f_{ND} may be increased.

OPERATING CHARACTERISTICS (continued): valid throughout full operating and temperature ranges, unless otherwise noted.

| Characteristics | Symbol | Test Conditions | Min. | Typ. [1] | Max. | Unit | |
|------------------------------------|-----------------|--|------------------|--------------------|------|------|---------|
| DAC CHARACTERISTICS | | | | | | | |
| Allowable User-Induced Offset | | Magnitude valid for both differential magnetic channels | -300 | - | 300 | G | |
| PERFORMANCE CHARACTERISTICS | | | | | | | |
| Operational Magnetic Range | B_{IN} | Peak to peak differential signal; valid for each magnetic channel. | 30 | - | 1200 | G | |
| Vibration Immunity (Startup) | $Err_{VIB(SU)}$ | See Figure 2 | -xxxxLxx variant | T_{TARGET} | - | - | degrees |
| | | | -xxxxHxx variant | T_{TARGET} | - | - | degrees |
| Vibration Immunity (Running Mode) | Err_{VIB} | See Figure 2 | -xxxxLxx variant | $0.12x T_{TARGET}$ | - | - | degrees |
| | | | -xxxxHxx variant | T_{TARGET} | - | - | degrees |

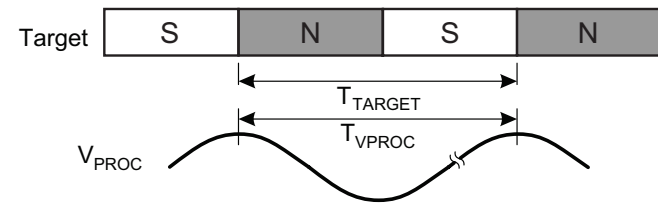

V_{PROC} = the processed analog signal of the sinusoidal magnetic input (per channel)

T_{TARGET} = the period between successive sensed target magnetic edges of the same polarity (either both north-to-south or both south-to-north)

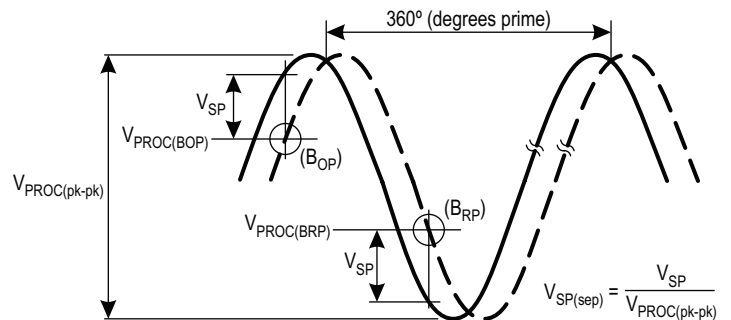

Figure 2: Definition of T_{TARGET}

¹ Typical values are at $T_A = 25^\circ C$ and $V_{CC} = 12 V$. Performance may vary for individual units, within the specified maximum and minimum limits.

OPERATING CHARACTERISTICS (continued): Valid throughout full operating and temperature ranges, unless otherwise noted.

| Characteristics | Symbol | Test Conditions | Min. | Typ. [1] | Max. | Unit | |
|---|-----------------------------|--|--|-----------------------|-------------------------|--------------------------|--------------|
| INPUT MAGNETIC CHARACTERISTICS | | | | | | | |
| Allowable Differential Sequential Signal Variation | $B_{SEQ(n+1)} / B_{SEQ(n)}$ | Signal cycle-to-cycle variation (see Figure 3) | -xxxxxxJ variant | 0.5 | – | – | – |
| | | | -xxxxxxQ variant | 0.6 | – | – | – |
| Allowable Differential Sequential Signal Variation | $B_{SEQ(n+i)} / B_{SEQ(n)}$ | Overall signal variation (see Figure 3) | -xxxxxxJ variant | 0.1 [2] | – | – | – |
| | | | -xxxxxxQ variant | 0.4 | – | – | – |
| CALIBRATION | | | | | | | |
| First Direction Output Pulse [3] | | Amount of target rotation (constant direction) following power-on until first electrical output pulse of either $t_{w(FWD)}$ or $t_{w(REV)}$. See Figure 2 | $B_{IN} > 60 G_{PP}$ $B_{IN} \leq 1200 G_{PP}$ | – | $2 \times T_{TARGET}$ | $< 3 \times T_{TARGET}$ | degrees |
| | | | $30 G_{PP} \leq B_{IN}$ $B_{IN} \leq 60 G_{PP}$ | – | $2.5 \times T_{TARGET}$ | $< 4 \times T_{TARGET}$ | degrees |
| First Direction-Pulse Output Following Direction Change | NCD | Amount of target rotation (constant direction) following event until first electrical output pulse of either $t_{w(FWD)}$ or $t_{w(REV)}$. $V_{SP(sep)} \geq 35$. See Figure 2 | -xxxxLxx variant | – | 1 | – | switch-point |
| | | | -xxxxHxx variant | $1 \times T_{TARGET}$ | $2 \times T_{TARGET}$ | $< 3 \times T_{TARGET}$ | degrees |
| First Direction-Pulse Output Following Running Mode Vibration | | Amount of target rotation (constant direction) following event until first electrical output pulse of either $t_{w(FWD)}$ or $t_{w(REV)}$. See Figure 2 | -xxxxLxx variant | – | – | $1.25 \times T_{TARGET}$ | degrees |
| | | | -xxxxHxx variant | $1 \times T_{TARGET}$ | $2 \times T_{TARGET}$ | $< 3 \times T_{TARGET}$ | degrees |
| Timer Period | | | -xxxxxKx variant | – | 0.5 | – | s |

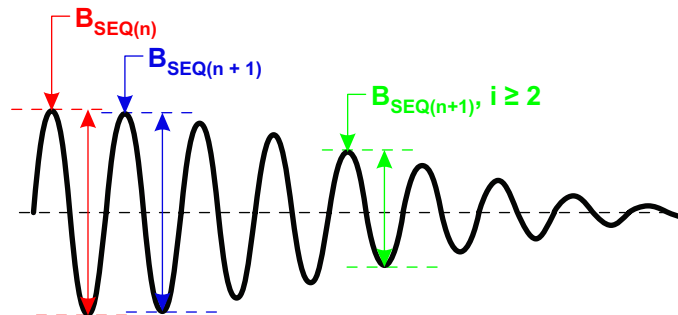

Figure 3: Differential Signal Variation

¹ Typical values are at $T_A = 25^\circ\text{C}$ and $V_{CC} = 12\text{ V}$. Performance may vary for individual units, within the specified maximum and minimum limits.

² Small value denotes high variation capability.

³ Power-up frequencies $\leq 200\text{ Hz}$. Higher power-on frequencies may require more input magnetic cycles until output edges are achieved.

THERMAL CHARACTERISTICS

| Characteristic | Symbol | Test Conditions* | Value | Unit |
|----------------------------|-----------------|---|-------|-----------------------------|
| Package Thermal Resistance | $R_{\theta JA}$ | Single-layer PCB with copper limited to solder pads | 213 | $^{\circ}\text{C}/\text{W}$ |

*Additional thermal information is available on the Allegro website.

Power Derating Curve

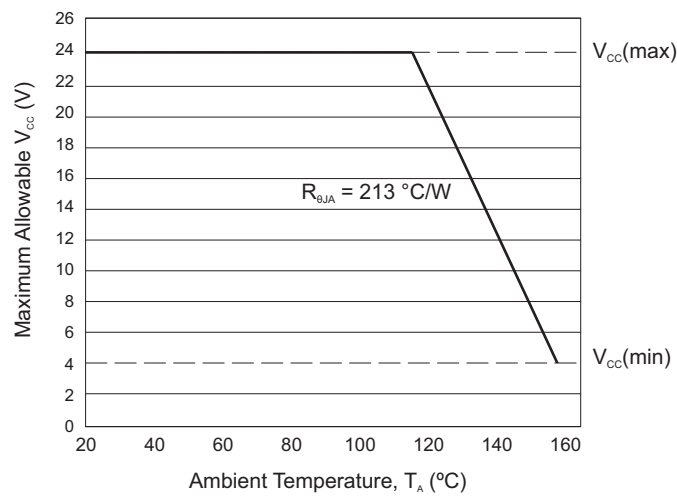

Power Dissipation versus Ambient Temperature

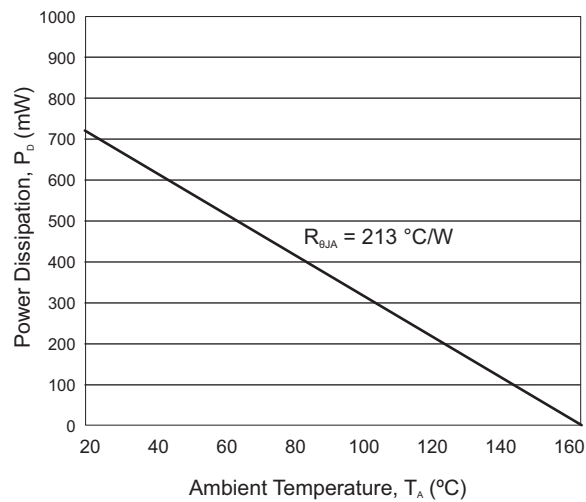

FUNCTIONAL DESCRIPTION

Sensing Technology

The sensor IC contains a single-chip Hall-effect circuit that supports a trio of Hall elements. These elements are used in differential pairs to provide electrical signals containing information regarding edge position and direction of target rotation. The ARS19510 is intended for use with ring magnet and gear targets.

After proper power is applied to the sensor IC, it is capable of providing digital information that is representative of the magnetic features of a rotating target. The waveform diagrams in Figure 4 present the automatic translation of the target profiles to the digital output signal of the sensor IC

Direction Detection

The sensor IC compares the relative phase of its two differential channels to determine which direction the target is moving. The relative switching order is used to determine the direction, which is communicated through the output protocol.

Data Protocol Description

When a target passes in front of the device (opposite the branded face of the package case), the ARS19510 generates an output pulse(s) for each pair of magnetic poles of the target. Speed information is provided by the output pulse rate, while direction of target rotation is provided by the duration of the output pulses. The sensor IC can sense target movement in both the forward and reverse directions.

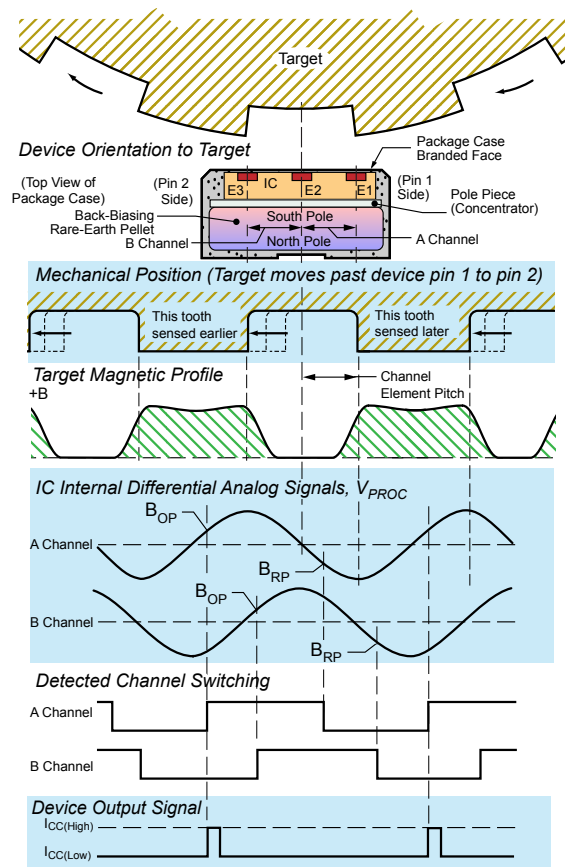
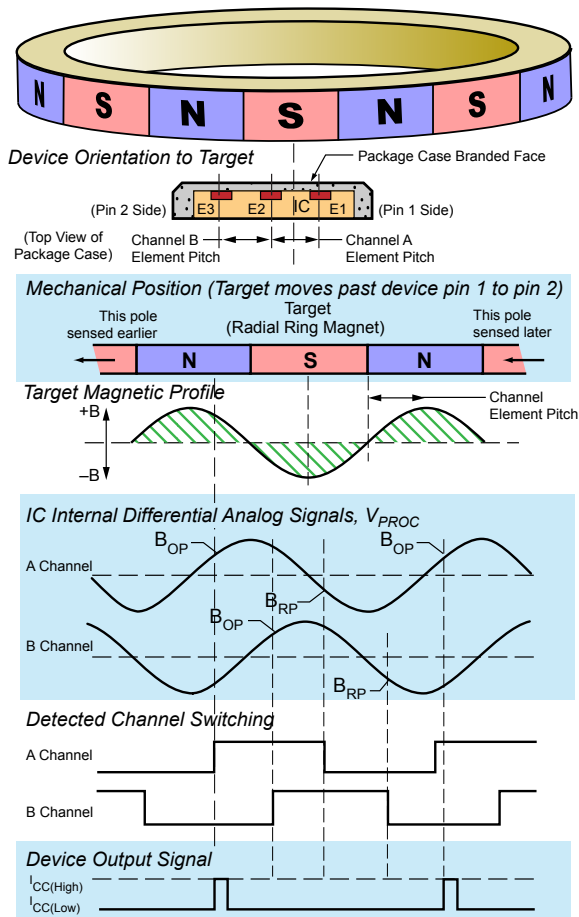

Figure 4: The magnetic profile reflects the features of the target, allowing the sensor IC to present an accurate digital output (-xSxxxx variant shown).

Forward Rotation (see Figure 5)

When the target is rotating such that a magnetic pole near the sensor IC (of -Fxxxxxx variant) passes from pin 1 to pin 2, this is referred to as forward rotation. This direction is opposite for the -Rxxxxxx variant. Forward rotation is indicated by output pulse widths of $t_{w(FWD)}$ (45 μ s typical).

Reverse Rotation (see Figure 5)

When the target is rotating such that a magnetic pole passes from pin 2 to pin 1, it is referred to as reverse rotation for the -Fxxxxxx variant. This direction is opposite for the -Rxxxxxx variant. Reverse rotation is indicated by output pulse widths of $t_{w(REV)}$ (90 μ s typical for -xxNxxxx variant, or 180 μ s typical for -xxWxxxx variant).

Timing

As shown in Figure 6, the pulse appears at the output slightly before the sensed magnetic edge traverses the package branded face. For targets rotating from pin 2 to 1, this shift (Δ fwd with R

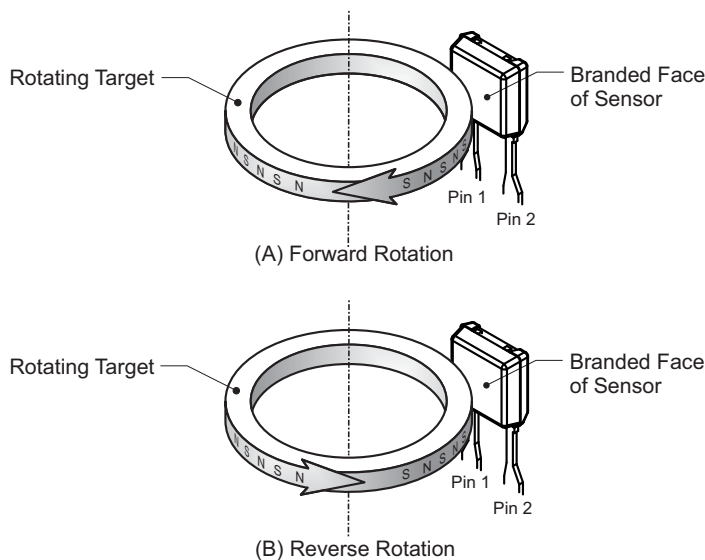

Figure 5: Target Rotation for -Fxxxxxx Variant.
-Rxxxxxx variant inverts detected direction of rotation.

variants, with south pole of backbiasing pellet toward IC) results in the pulse corresponding to the valley with the sensed mechanical edge; for targets rotating from pin 1 to 2, the shift (Δ rev) results in the pulse corresponding to the tooth with the sensed edge. Figure 7 shows pulse timing for F variants. The sensed mechanical edge that stimulates output pulses is kept the same for both forward and reverse rotation by using only one channel to control output switching.

Direction Validation

For the -xxxxLxx variant, following a direction change in running mode, direction changes are immediately transmitted to the output.

For the -xxxxHxx variant, following a direction change in running mode, output pulses have a width of $t_{w(ND)}$ until direction information is validated.

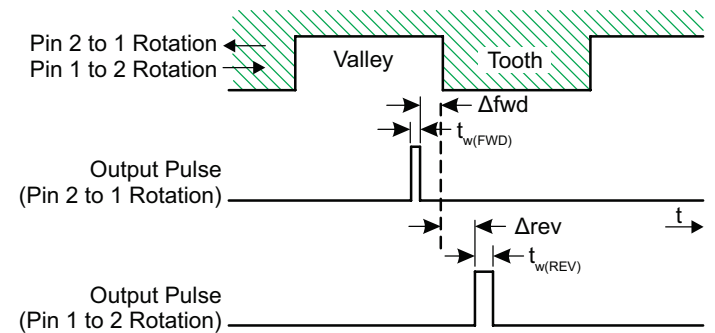

Figure 6: Output Protocol (-RSxxxxxx variant)

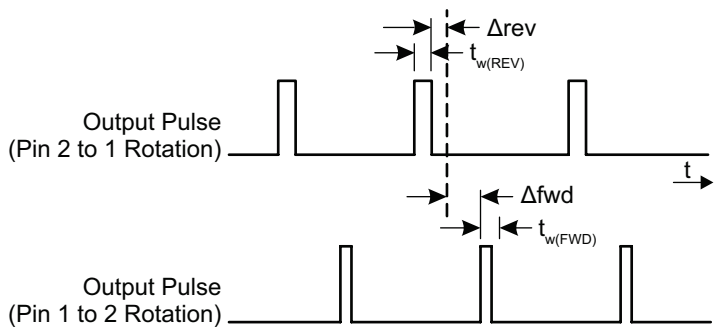

Figure 7: Output Protocol (-FDxxxxxx variant)

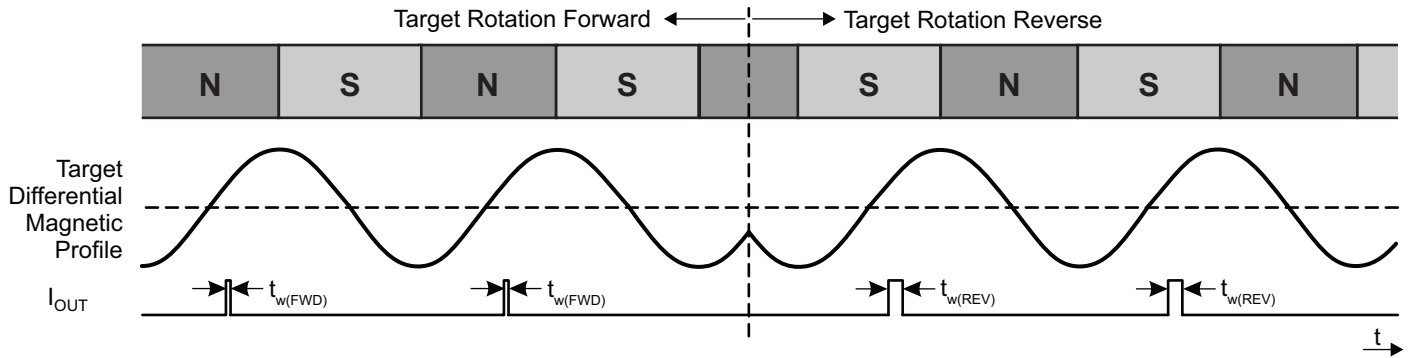

Figure 8: Example Running Mode Direction Change (-FSxxLxx variant)

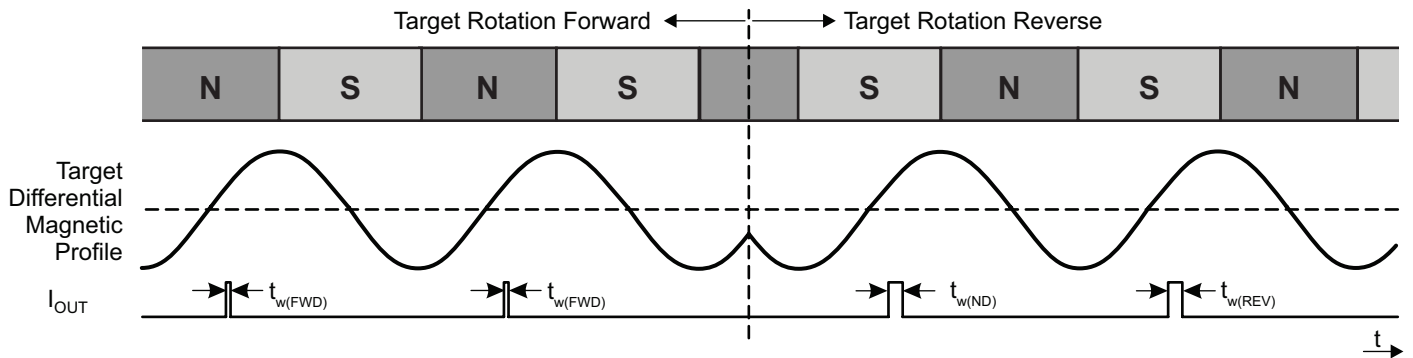

Figure 9: Example Running Mode Direction Change (-FSxxHxx variant)

Startup Detection/Calibration

When power is applied to the ARS19510, the sensor IC internally detects the profile of the target. The gain and offset of the detected signals are adjusted during the calibration period, normalizing the internal signal amplitude for the air gap range of the device.

The Automatic Gain Control (AGC) feature ensures that operational characteristics are isolated from the effects of installation air gap variation.

Automatic Offset Adjustment (AOA) is circuitry that compensates for the effects of chip, magnet, and installation offsets. This circuitry works with the AGC during calibration to adjust

VPROC in the internal A-to-D range to allow for acquisition of signal peaks. AOA and AGC function separately on the two differential signal channels.

Direction information is available after calibration is complete.

For the -xxxBxxx variant, the output becomes active at the end of calibration. Figure 10 shows where the first output edges may occur for various starting target phases.

For the -xxxPxxx variant, output pulses of $t_{w(ND)}$ are supplied during calibration. Figure 11 shows where the first output edges may occur for various starting target phases.

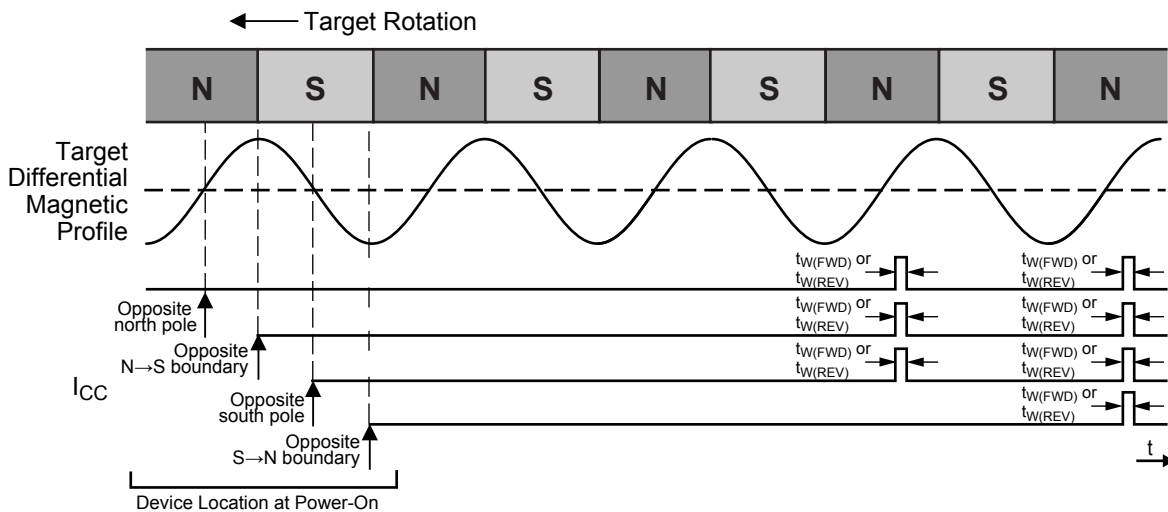

Figure 10: Startup Position Effect on First Device Output Switching (-xxxBxxx variant)

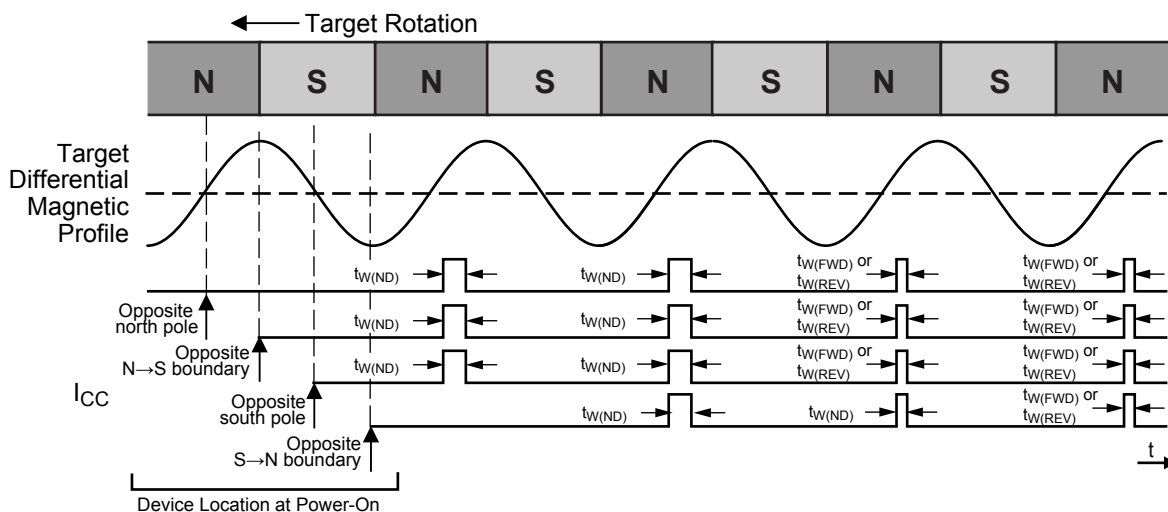

Figure 11: Startup Position Effect on First Device Output Switching (-xxxPxxx variant)

Vibration Detection

Algorithms embedded in the IC's digital controller detect the presence of target vibration through analysis of the two magnetic input channels.

For the -xxxxLxx variant, the first direction change is immediately transmitted to the output. During any subsequent vibration, the output is blanked and no output pulses will occur for vibrations less than the specified vibration immunity. Output pulses

containing the proper direction information will resume when direction information is validated on constant target rotation.

For the -xxxxHxx variant, in the presence of vibration, output pulses of $t_{w(ND)}$ may occur or no pulses may occur, depending on the amplitude and phase of the vibration. Output pulses have a width of $t_{w(ND)}$ until direction information is validated on constant target rotation.

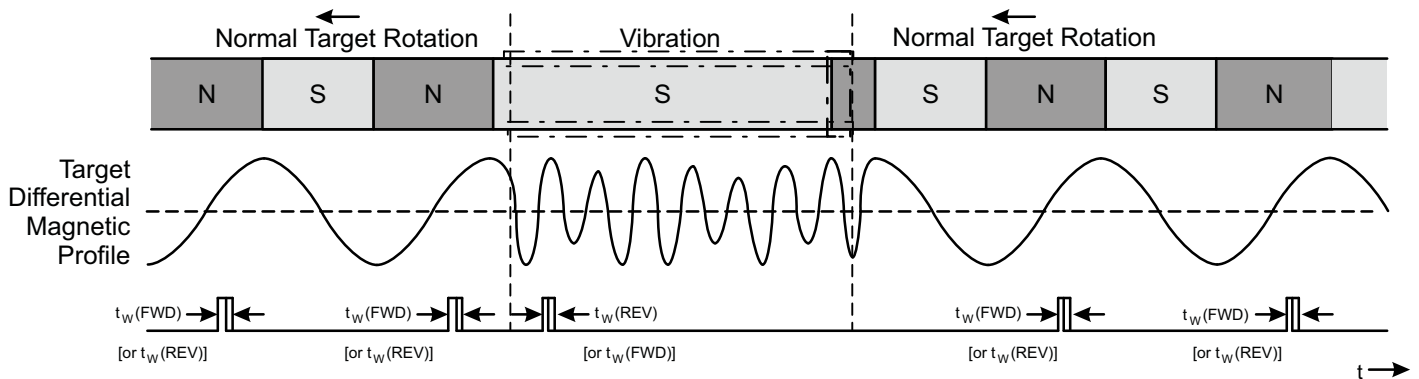

Figure 12: Output Functionality in the Presence of Running Mode Target Vibration (-xxxxLxx variant)

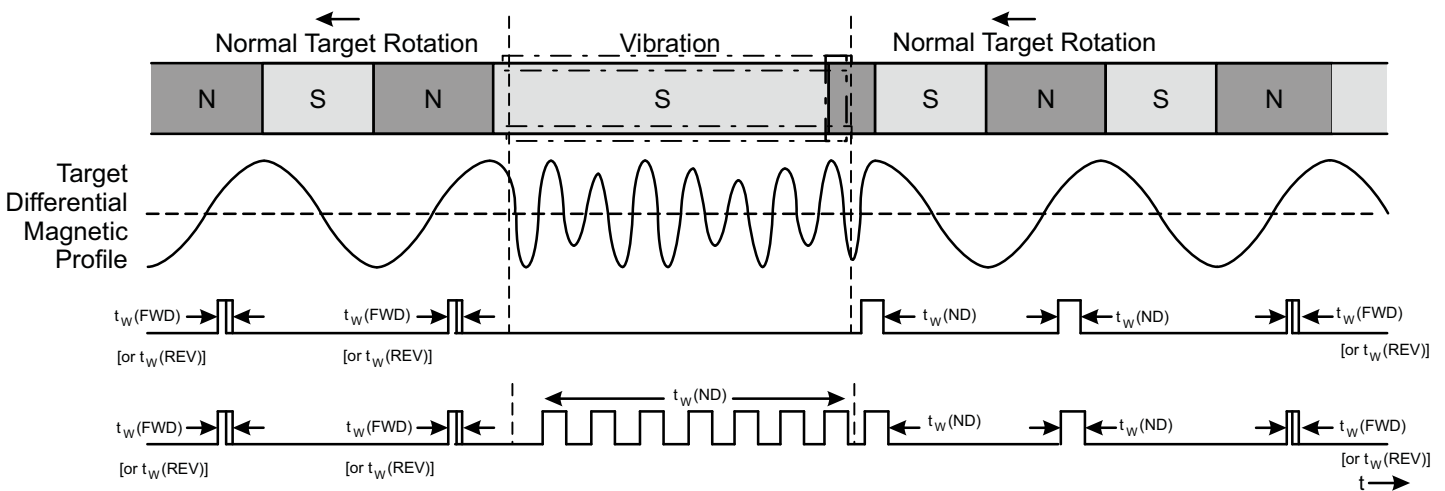

Figure 13: Output Functionality in the Presence of Running Mode Target Vibration (-xxxxHxx variant)

POWER DERATING

The device must be operated below the maximum junction temperature of the device, $T_{J(max)}$. Under certain combinations of peak conditions, reliable operation may require derating supplied power or improving the heat dissipation properties of the application. This section presents a procedure for correlating factors affecting operating T_J . (Thermal data is also available on the Allegro MicroSystems website.)

The Package Thermal Resistance, $R_{\theta JA}$, is a figure of merit summarizing the ability of the application and the device to dissipate heat from the junction (die), through all paths to the ambient air. Its primary component is the Effective Thermal Conductivity, UB, of the printed circuit board, including adjacent devices and traces. Radiation from the die through the device case, $R_{\theta JC}$, is relatively small component of $R_{\theta JA}$. Ambient air temperature, T_A , and air motion are significant external factors, damped by overmolding.

The effect of varying power levels (Power Dissipation, P_D), can be estimated. The following formulas represent the fundamental relationships used to estimate T_J , at P_D .

$$P_D = V_{IN} \times I_{IN} \quad (1)$$

$$\Delta T = P_D \times R_{\theta JA} \quad (2)$$

$$T_J = T_A + \Delta T \quad (3)$$

For example, given common conditions such as: $T_A = 25^\circ C$, $V_{CC} = 12 V$, $R_{\theta JA} = 213^\circ C/W$, and $I_{CC} = 6.5 mA$, then:

$$P_D = V_{CC} \times I_{CC} = 12 V \times 6.5 mA = 78 mW$$

$$\Delta T = P_D \times R_{\theta JA} = 78 mW \times 213^\circ C/W = 16.6^\circ C$$

$$T_J = T_A + \Delta T = 25^\circ C + 16.6^\circ C = 41.6^\circ C$$

A worst-case estimate, $P_{D(max)}$, represents the maximum allowable power level ($V_{CC(max)}$, $I_{CC(max)}$), without exceeding $T_{J(max)}$, at a selected $R_{\theta JA}$ and T_A .

Example: Reliability for V_{CC} at $T_A = 150^\circ C$.

Observe the worst-case ratings for the device, specifically:

$R_{\theta JA} = 213^\circ C/W$, $T_{J(max)} = 165^\circ C$, $V_{CC(max)} = 24 V$, and $I_{CC(mean)} = 14.8 mA$. (Note: For variant -xxWPxxx, at maximum target frequency, $I_{CC(LOW)} = 8 mA$, $I_{CC(HIGH)} = 16 mA$, and maximum pulse widths, the result is a duty cycle of 84% and thus a worst-case mean I_{CC} of 14.8 mA.)

Calculate the maximum allowable power level, $P_{D(max)}$. First, invert equation 3:

$$\Delta T_{max} = T_{J(max)} - T_A = 165^\circ C - 150^\circ C = 15^\circ C$$

This provides the allowable increase to T_J resulting from internal power dissipation. Then, invert equation 2:

$$P_{D(max)} = \Delta T_{max} \div R_{\theta JA} = 15^\circ C \div 213^\circ C/W = 70.4 mW$$

Finally, invert equation 1 with respect to voltage:

$$V_{CC(est)} = P_{D(max)} \div I_{CC(max)} = 70.4 mW \div 14.8 mA = 4.7 V$$

The result indicates at T_A , the application and device can dissipate adequate amounts of heat at voltages $\leq V_{CC(est)}$.

Compare $V_{CC(est)}$ to $V_{CC(max)}$. If $V_{CC(est)} \leq V_{CC(max)}$, then reliable operation between $V_{CC(est)}$ and $V_{CC(max)}$ requires enhanced $R_{\theta JA}$. If $V_{CC(est)} \geq V_{CC(max)}$, then operation between $V_{CC(est)}$ and $V_{CC(max)}$ is reliable under these conditions.

ARS19510LUB

Two-Wire, Differential, Vibration-Resistant Sensor IC with Speed and Direction Output

PACKAGE OUTLINE DRAWING

For Reference Only – Not for Tooling Use

(Reference DWG-0000408, Rev. 4)

Dimensions in millimeters – NOT TO SCALE

Exact case and lead configuration at supplier discretion within limits shown

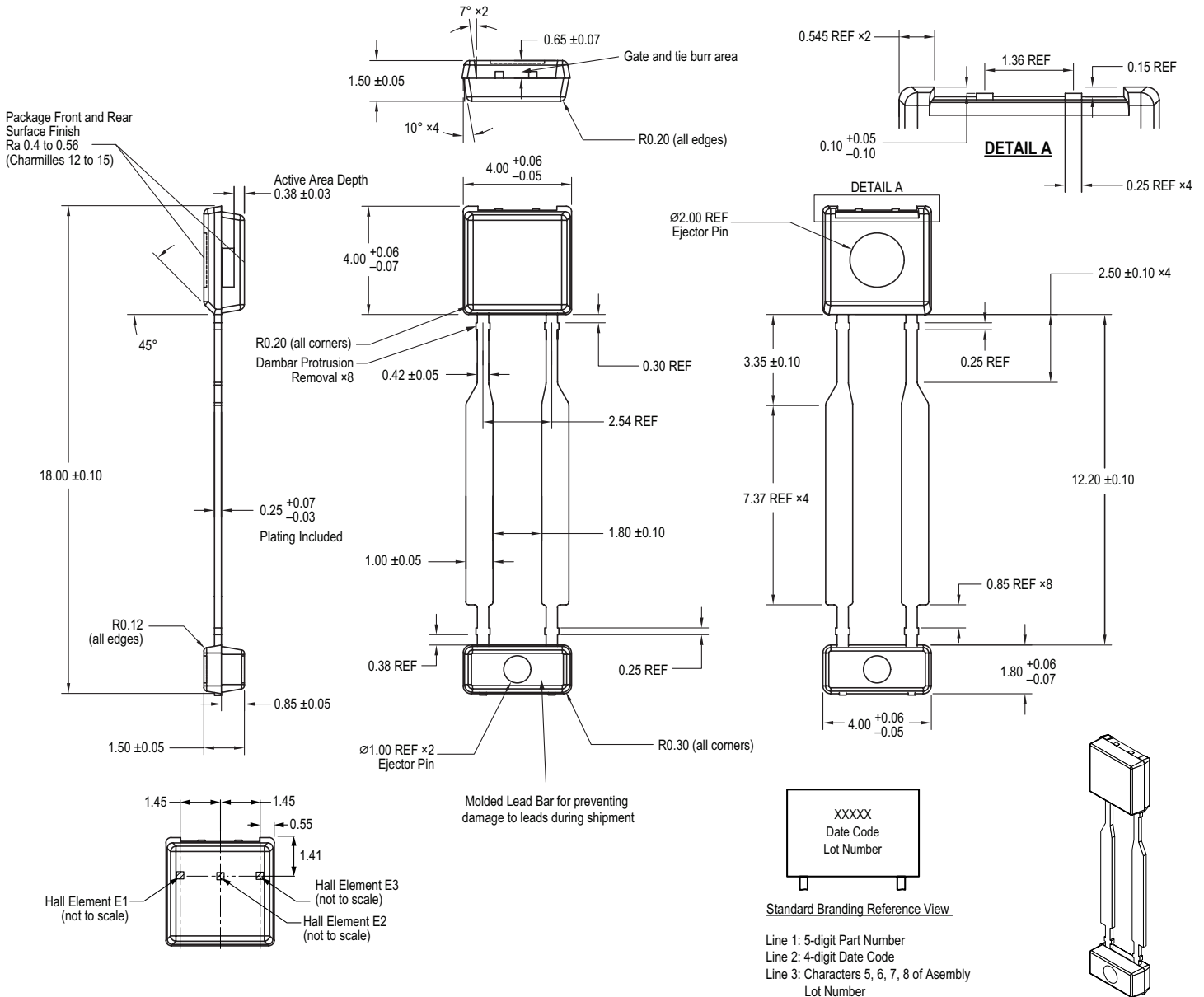

Branding scale and appearance at supplier discretion

Figure 14: Package UB, 2-Pin SIP

Revision History

| Number | Date | Description |
|--------|-------------------|---|
| – | March 7, 2017 | Initial release |
| 1 | May 23, 2017 | Updated Selection Guide (page 2, clarified Forward Rotation Direction option) |
| 2 | November 17, 2017 | Updated Selection Guide table (page 2) |
| 3 | December 4, 2018 | Updated Package Outline Drawing (page 15), and minor editorial updates |
| 4 | January 6, 2020 | Minor editorial updates |
| 5 | January 16, 2023 | Updated package drawing (page 15). |

Copyright 2023, Allegro MicroSystems.

Allegro MicroSystems reserves the right to make, from time to time, such departures from the detail specifications as may be required to permit improvements in the performance, reliability, or manufacturability of its products. Before placing an order, the user is cautioned to verify that the information being relied upon is current.

Allegro's products are not to be used in any devices or systems, including but not limited to life support devices or systems, in which a failure of Allegro's product can reasonably be expected to cause bodily harm.

The information included herein is believed to be accurate and reliable. However, Allegro MicroSystems assumes no responsibility for its use; nor for any infringement of patents or other rights of third parties which may result from its use.

Copies of this document are considered uncontrolled documents.

For the latest version of this document, visit our website:

www.allegromicro.com

Looking for pricing, stock, or lifecycle information?

Click below to explore more details on WIN SOURCE:

- ⊖ [View ARS19510LUBBTN-RSWPHUJ on WIN SOURCE](#)
- ⊖ [Allegro MicroSystems, LLC Information](#)

Optimize Your Supply Chain with WIN SOURCE Solutions

- ✓ Global Sourcing Solution
- ✓ Obsolete Management
- ✓ Cost Control Management
- ✓ Shortage Management
- ✓ Alternative Solution
- ✓ Excess Inventory Management