



**THE DATASHEET OF
A1245LLHLT-I1-T**



Chopper-Stabilized Two-Wire Hall-Effect Latch

FEATURES AND BENEFITS

- High speed, 4-phase chopper stabilization
 - Low switch point drift throughout temperature range
 - Low sensitivity to thermal and mechanical stresses
- On-chip protection
 - Supply transient protection
 - Reverse battery protection
- On-board voltage regulator
 - 3.0 to 24 V operation
- Operation up to 175°C junction temperature
- Solid-state reliability
- Industry-leading ISO 7637-2 performance through use of proprietary, 40 V clamping structures

PACKAGES



3-pin ultramini SIP
1.5 × 4 × 3 mm
(suffix UA)

Not to scale



3-pin SOT23-W
2 × 3 × 1 mm
(suffix LH)

DESCRIPTION

The A1245 is a two-wire Hall-effect latch. The device is produced on the Allegro™ advanced BiCMOS wafer fabrication process, which implements a high frequency, 4-phase, chopper-stabilization technique. This technique achieves magnetic stability over the full operating temperature range and eliminates offsets inherent in devices with a single Hall element that are exposed to harsh application environments.

Two-wire latches are particularly advantageous in cost-sensitive applications because they require one less wire for operation versus the more traditional open-collector output switches. Additionally, the system designer inherently gains diagnostics because there is always output current flowing, which should be in either of two narrow ranges. Any current level not within these ranges indicates a fault condition.

The Hall-effect latch will be in the high output current state in the presence of a magnetic south polarity field of sufficient magnitude and will remain in this state until a sufficient north polarity field is present.

The device is offered in two package styles. The LH is a SOT-23W style, miniature low-profile package for surface-mount applications. The UA is a 3-pin ultra-mini single in line packages (SIP) for through-hole mounting. Both packages are lead (Pb) free, with 100% matte tin leadframe plating.

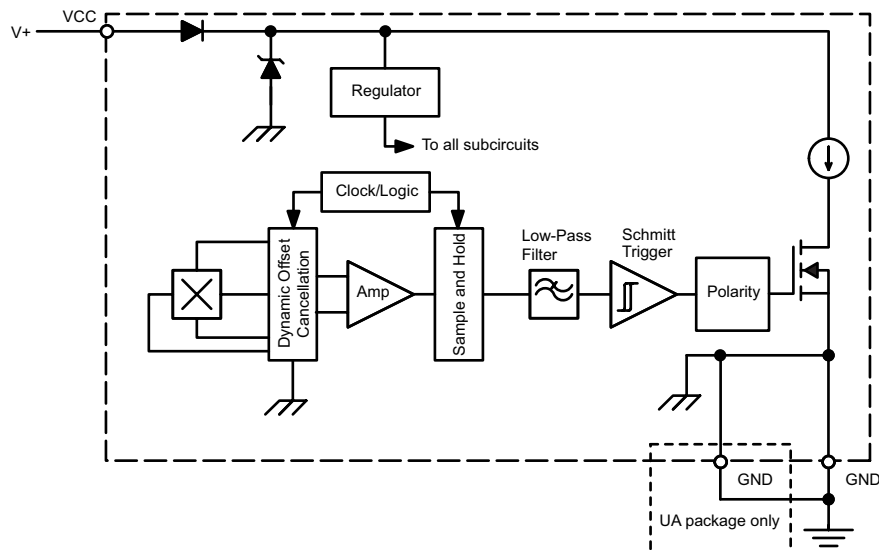

Functional Block Diagram

SELECTION GUIDE

Part Number	Packing [1]	Package	Operating Ambient Temperature, T_A (°C)	Supply Current at $I_{CC(L)}$ (mA)
A1245LLHLX-I1-T	13-in. reel, 10000 pieces/reel	3-pin SOT23W surface mount	-40 to 150	5 to 6.9
A1245LLHLX-I2-T	13-in. reel, 10000 pieces/reel	3-pin SOT23W surface mount	-40 to 150	2 to 5
A1245LUA-I1-T	Bulk, 500 pieces/bag	3-pin SIP through hole	-40 to 150	5 to 6.9
A1245LUA-I2-T	Bulk, 500 pieces/bag	3-pin SIP through hole	-40 to 150	2 to 5

[1] Contact Allegro for additional packing options



SPECIFICATIONS

ABSOLUTE MAXIMUM RATINGS

Characteristic	Symbol	Notes	Rating	Unit
Forward Supply Voltage [2]	V_{CC}		28	V
Reverse Supply Voltage [2]	V_{RCC}		-18	V
Magnetic Flux Density	B		Unlimited	G
Operating Ambient Temperature	T_A	Range L	-40 to 150	°C
Maximum Junction Temperature	$T_J(max)$		165	°C
		For 500 hours	175	°C
Storage Temperature	T_{stg}		-65 to 170	°C

[2] This rating does not apply to extremely short voltage transients such as load dump and/or ESD. Those events have individual ratings, specific to the respective transient voltage event.

PINOUT DIAGRAMS AND TERMINAL LIST TABLE

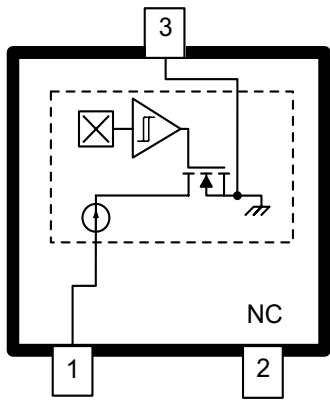

**LH Package, 3-Pin
SOT23W Pinout**

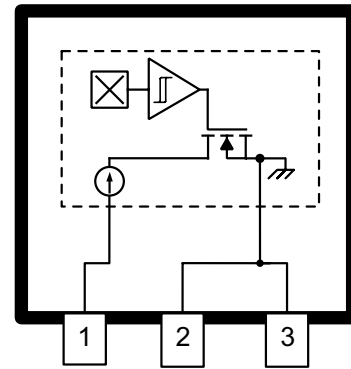

**UA Package, 3-Pin SIP
Pinout**

Terminal List Table

Name	Number		Function
	LH	UA	
VCC	1	1	Connects power supply to chip.
NC	2	N/A	No connection; tie to GND for improved thermal characteristics, or float.
GND	3	2, 3	Ground; tie both to GND for improved thermal characteristics, or float unused GND pin.

ELECTRICAL CHARACTERISTICS: Valid at $T_A = -40^\circ\text{C}$ to 150°C , $T_J < T_{J(\text{max})}$; for LH and UA: $C_{\text{BYP}} = 0.01 \mu\text{F}$; through operating supply voltage range, unless otherwise noted

Characteristics	Symbol	Test Conditions	Min.	Typ.	Max.	Unit
Supply Voltage [1][2]	V_{CC}	Operating	3.0	–	24	V
Supply Current	$I_{\text{CC(L)}}$	-I1 $B < B_{\text{RP}}$	5	–	6.9	mA
		-I2 $B < B_{\text{RP}}$	2	–	5	mA
	$I_{\text{CC(H)}}$	$B > B_{\text{OP}}$	12	–	17	mA
Supply Zener Clamp Voltage	$V_{\text{Z(sup)}}$	$I_{\text{CC(L)(max)}} + 3 \text{ mA}$, $T_A = 25^\circ\text{C}$	28	–	–	V
Supply Zener Clamp Current	$I_{\text{Z(sup)}}$	$V_{\text{Z(sup)}} = 28 \text{ V}$	–	–	$I_{\text{CC(L)(max)}} + 3 \text{ mA}$	mA
Reverse Supply Current	I_{RCC}	$V_{\text{RCC}} = -18 \text{ V}$	–	–	-1.6	mA
Output Slew Rate [3]	dI/dt	No external bypass capacitor, capacitance of probe $C_S = 20 \text{ pF}$	–	90	–	mA/ μs
Chopping Frequency [5]	f_c		–	700	–	kHz
Power-Up Time [2][4][5]	t_{on}	$V_{\text{CC}} \geq V_{\text{CC(min)}}$	–	–	25	μs
Power-Up State [4][6][7]	POS	$t_{\text{on}} < t_{\text{on(max)}}$, V_{CC} slew rate $> 25 \text{ mV}/\mu\text{s}$	–	$I_{\text{CC(H)}}$	–	–

[1] V_{CC} represents the generated voltage between the VCC pin and the GND pin.

[2] The V_{CC} slew rate must exceed 600 mV/ms from 0 to $V_{\text{CC(min)}}$. A slower slew rate through this range can affect device performance.

[3] Measured without bypass capacitor between VCC and GND. Use of a bypass capacitor results in slower current change.

[4] Power-Up Time is measured with and without an external bypass capacitor of 0.01 μF , $B < B_{\text{RP}} - 10 \text{ G}$. Adding a larger bypass capacitor would cause longer Power-Up Time.

[5] Guaranteed by characterization and design.

[6] Power-Up State as defined is true only with a V_{CC} slew rate of 25 mV/ μs or greater.

[7] Power-Up State is defined during the power-on phase ($t < t_{\text{ON}}$) until the device has fully powered-on (t_{ON}), after which the output will correspond to the magnetic field level seen by the sensor. For $t > t_{\text{on}}$ and $B_{\text{RP}} < B < B_{\text{OP}}$, Power-Up State is not defined.

MAGNETIC CHARACTERISTICS [8]: Valid at $T_A = -40^\circ\text{C}$ to 150°C , $T_J < T_{J(\text{max})}$; for LH and UA: $C_{\text{BYP}} = 0.01 \mu\text{F}$; through operating supply voltage range, unless otherwise noted

Characteristics	Symbol	Test Conditions	Min.	Typ.	Max.	Unit [9]
Magnetic Operating Point	B_{OP}		5	–	40	G
Magnetic Release Point	B_{RP}		-40	–	-5	G
Hysteresis	B_{HYS}	$B_{\text{OP}} - B_{\text{RP}}$	15	40	65	G

[8] Relative values of B use the algebraic convention, where positive values indicate south magnetic polarity, and negative values indicate north magnetic polarity; therefore greater B values indicate a stronger south polarity field (or a weaker north polarity field, if present).

[9] 1 G (gauss) = 0.1 mT (millitesla).

THERMAL CHARACTERISTICS may require derating at maximum conditions, see application information

Characteristic	Symbol	Test Conditions*	Value	Units
Package Thermal Resistance	$R_{\theta JA}$	Package LH, 1-layer PCB with copper limited to solder pads	228	$^{\circ}\text{C}/\text{W}$
		Package LH, 2-layer PCB with 0.463 in. ² of copper area each side connected by thermal vias	110	$^{\circ}\text{C}/\text{W}$
		Package UA, 1-layer PCB with copper limited to solder pads	165	$^{\circ}\text{C}/\text{W}$

*Additional thermal information available on Allegro Web site.

Power Derating Curve

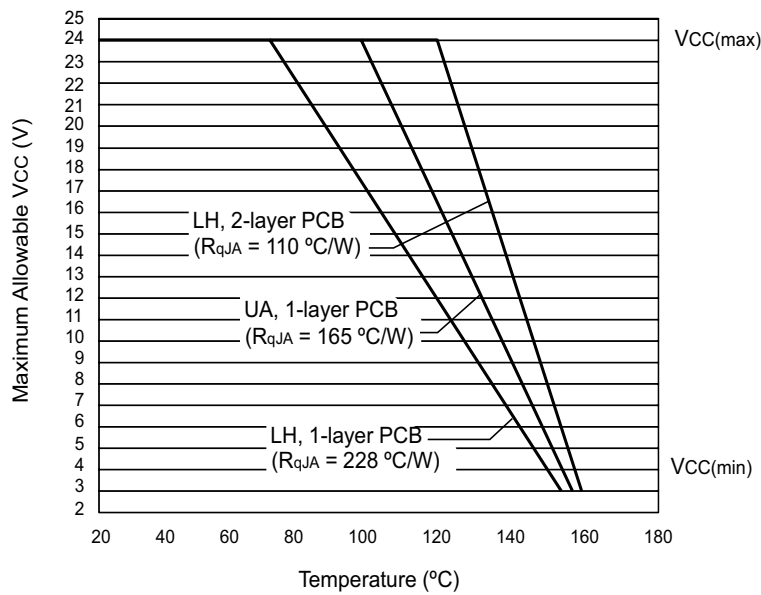

Maximum Power Dissipation versus Ambient Temperature

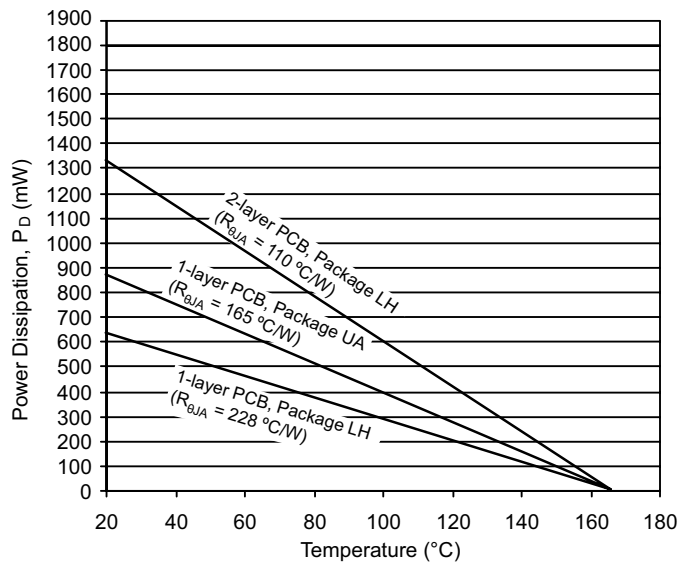

CHARACTERISTIC PERFORMANCE

Average Supply Current (Low) vs. Temperature

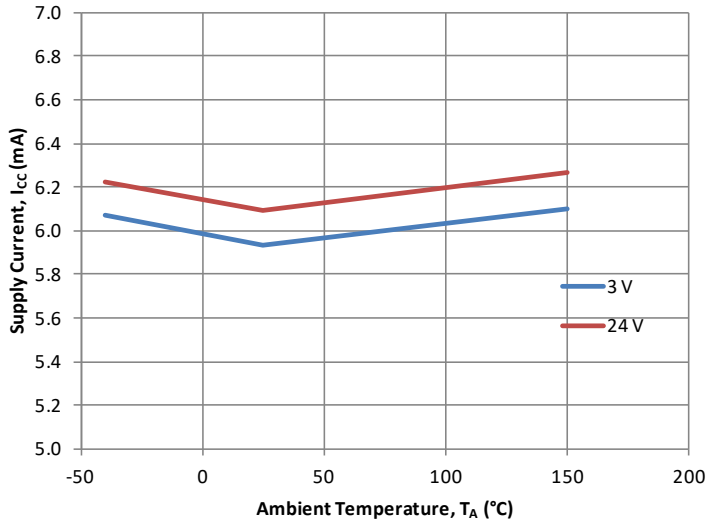

Average Supply Current (Low) vs. Supply Voltage

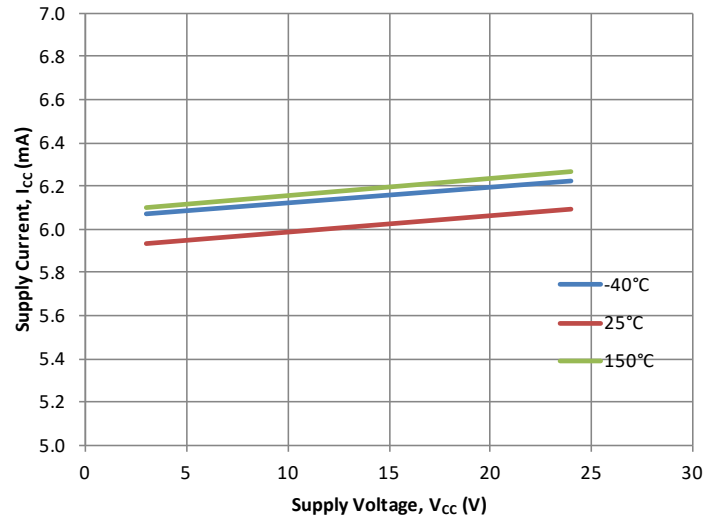

Average Supply Current (High) vs. Temperature

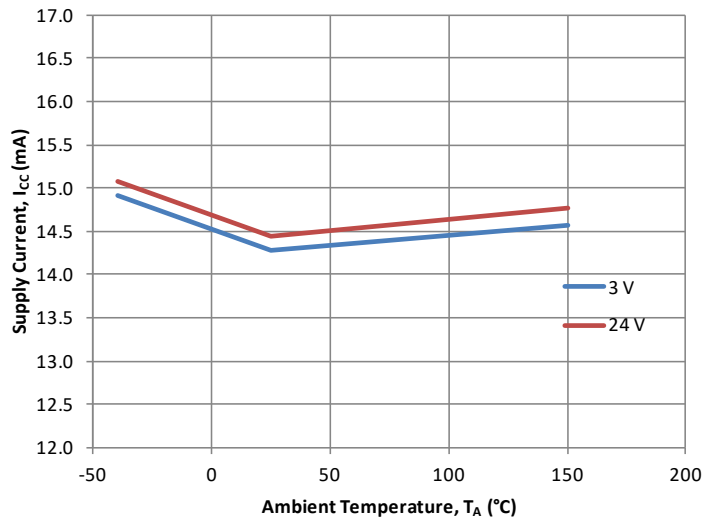

Average Supply Current (High) vs. Supply Voltage

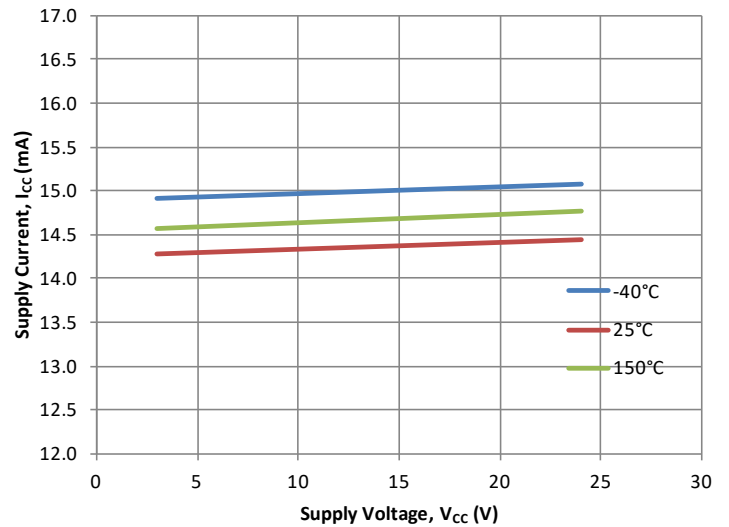

Average B_{OP} vs. Temperature

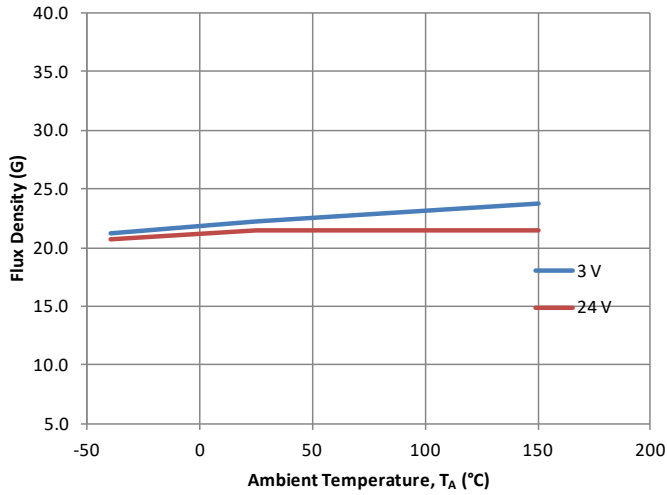

Average B_{OP} vs. Supply Voltage

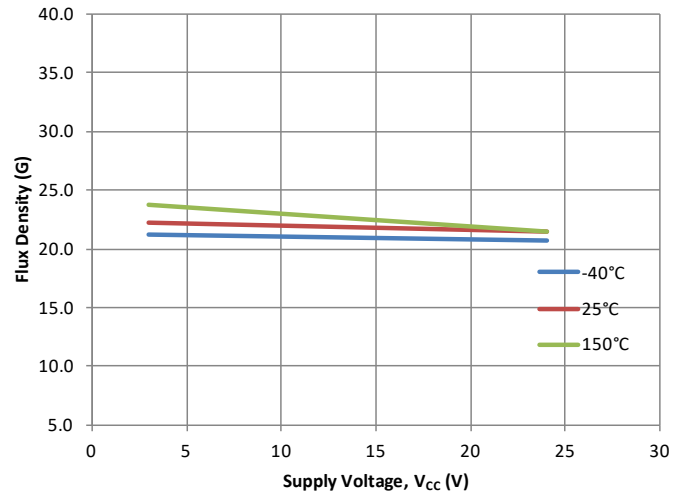

Average B_{RP} vs. Temperature

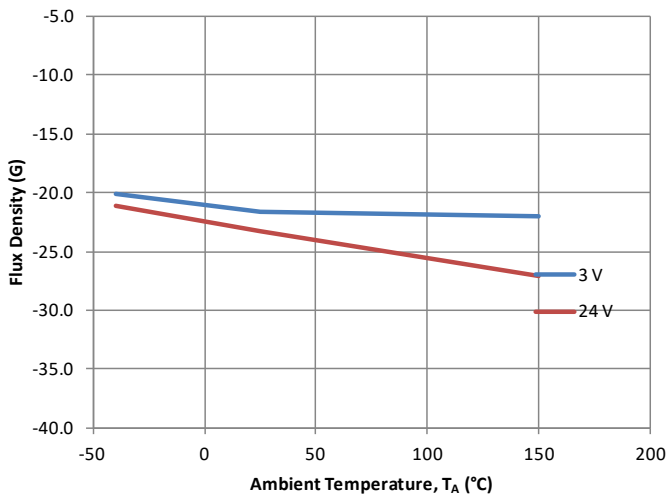

Average B_{RP} vs. Supply Voltage

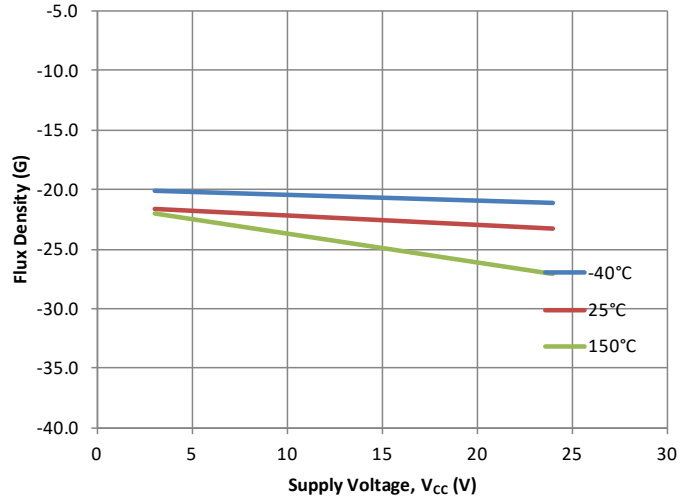

Average B_{HYS} vs. Temperature

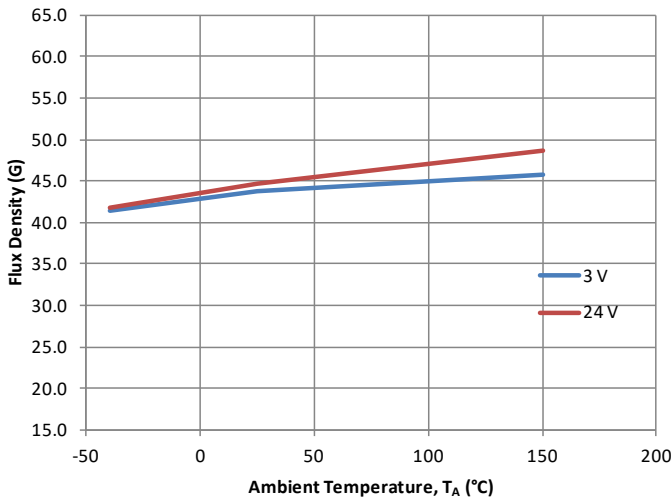

Average B_{HYS} vs. Supply Voltage

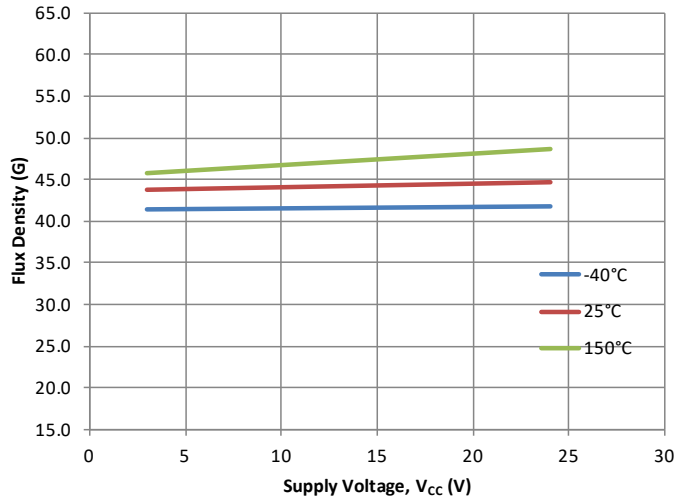

FUNCTIONAL DESCRIPTION

The A1245 output, I_{CC} , switches high after the magnetic field at the Hall sensor IC exceeds the operate point threshold, B_{OP} . When the magnetic field is reduced to below the release point threshold, B_{RP} , the device output goes low. This is shown in Figure 1.

The difference between the magnetic operate and release points is called the hysteresis of the device, B_{HYS} . This built-in hysteresis allows clean switching of the output even in the presence of external mechanical vibration and electrical noise.

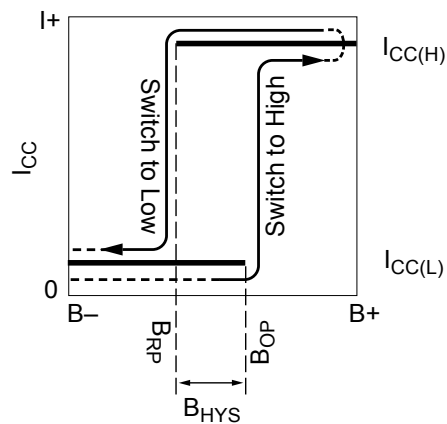

Figure 1: Hysteresis for the A1245

On the horizontal axis, the B+ direction indicates increasing south polarity magnetic field strength, and the B- direction indicates decreasing south polarity field strength (including the case of increasing north polarity).

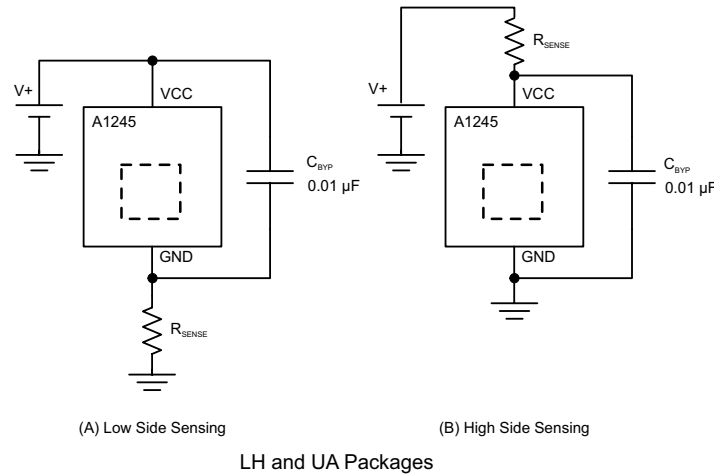

Figure 2: Typical Application Circuits

Chopper Stabilization Technique

When using Hall-effect technology, a limiting factor for switchpoint accuracy is the small signal voltage developed across the Hall element. This voltage is disproportionately small relative to the offset that can be produced at the output of the Hall sensor IC. This makes it difficult to process the signal while maintaining an accurate, reliable output over the specified operating temperature and voltage ranges. Chopper stabilization is a unique approach used to minimize Hall offset on the chip. The Allegro technique, namely Dynamic Quadrature Offset Cancellation, removes key sources of the output drift induced by thermal and mechanical stresses. This offset reduction technique is based on a signal modulation-demodulation process. The undesired offset signal is separated from the magnetic field-induced signal in the frequency domain, through modulation. The subsequent demodulation acts as a modulation process for the offset, causing the magnetic field-induced signal to recover its original spectrum

at base band, while the DC offset becomes a high-frequency signal. The magnetic-sourced signal then can pass through a low-pass filter, while the modulated DC offset is suppressed. The chopper stabilization technique uses a 350 kHz high frequency clock. For demodulation process, a sample-and-hold technique is used, where the sampling is performed at twice the chopper frequency. This high-frequency operation allows a greater sampling rate, which results in higher accuracy and faster signal-processing capability. This approach desensitizes the chip to the effects of thermal and mechanical stresses and produces devices that have extremely stable quiescent Hall output voltages and precise recoverability after temperature cycling. This technique is made possible through the use of a BiCMOS process, which allows the use of low-offset, low-noise amplifiers in combination with high-density logic integration and sample-and-hold circuits.

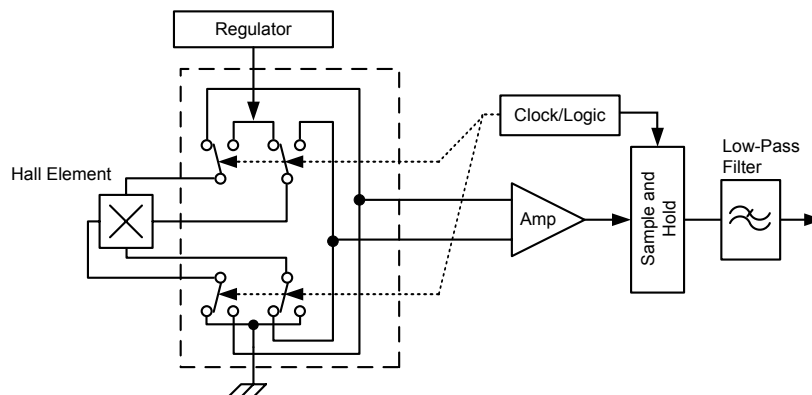

Figure 3: Chopper Stabilization Circuit (Dynamic Quadrature Offset Cancellation)

Power Derating

The device must be operated below the maximum junction temperature of the device, $T_J(\max)$. Under certain combinations of peak conditions, reliable operation may require derating supplied power or improving the heat dissipation properties of the application. This section presents a procedure for correlating factors affecting operating T_J . (Thermal data is also available on the Allegro MicroSystems website.)

The Package Thermal Resistance, $R_{\theta JA}$, is a figure of merit summarizing the ability of the application and the device to dissipate heat from the junction (die), through all paths to the ambient air. Its primary component is the Effective Thermal Conductivity, K , of the printed circuit board, including adjacent devices and traces. Radiation from the die through the device case, $R_{\theta JC}$, is relatively small component of $R_{\theta JA}$. Ambient air temperature, T_A , and air motion are significant external factors, damped by overmolding.

The effect of varying power levels (Power Dissipation, P_D) can be estimated. The following formulas represent the fundamental relationships used to estimate T_J , at P_D .

$$P_D = V_{IN} \times I_{IN} \quad (1)$$

$$\Delta T = P_D \times R_{\theta JA} \quad (2)$$

$$T_J = T_A + \Delta T \quad (3)$$

For example, given common conditions such as: $T_A = 25^\circ\text{C}$, $V_{CC} = 12\text{ V}$, $I_{CC} = 9\text{ mA}$, and $R_{\theta JA} = 110\text{ }^\circ\text{C/W}$, then:

$$P_D = V_{CC} \times I_{CC} = 12\text{ V} \times 9\text{ mA} = 108\text{ mW}$$

$$\Delta T = P_D \times R_{\theta JA} = 108\text{ mW} \times 110\text{ }^\circ\text{C/W} = 11.9^\circ\text{C}$$

$$T_J = T_A + \Delta T = 25^\circ\text{C} + 11.9^\circ\text{C} = 36.9^\circ\text{C}$$

A worst-case estimate, $P_D(\max)$, represents the maximum allowable power level ($V_{CC}(\max)$, $I_{CC}(\max)$), without exceeding $T_J(\max)$, at a selected $R_{\theta JA}$ and T_A .

Example: Reliability for V_{CC} at $T_A = 150^\circ\text{C}$, package LH, using a low-K PCB.

Observe the worst-case ratings for the device, specifically: $R_{\theta JA} = 110\text{ }^\circ\text{C/W}$, $T_J(\max) = 175^\circ\text{C}$, $V_{CC}(\max) = 24\text{ V}$, and $I_{CC}(\max) = 17\text{ mA}$.

Calculate the maximum allowable power level, $P_D(\max)$. First, invert equation 3:

$$\Delta T_{\max} = T_J(\max) - T_A = 175^\circ\text{C} - 150^\circ\text{C} = 25^\circ\text{C}$$

This provides the allowable increase to T_J resulting from internal power dissipation. Then, invert equation 2:

$$P_D(\max) = \Delta T_{\max} \div R_{\theta JA} = 25^\circ\text{C} \div 110\text{ }^\circ\text{C/W} = 227\text{ mW}$$

Finally, invert equation 1 with respect to voltage:

$$V_{CC(\text{est})} = P_D(\max) \div I_{CC}(\max) = 227\text{ mW} \div 17\text{ mA} = 13.3\text{ V}$$

The result indicates that, at T_A , the application and device can dissipate adequate amounts of heat at voltages $\leq V_{CC(\text{est})}$.

Compare $V_{CC(\text{est})}$ to $V_{CC}(\max)$. If $V_{CC(\text{est})} \leq V_{CC}(\max)$, then reliable operation between $V_{CC(\text{est})}$ and $V_{CC}(\max)$ requires enhanced $R_{\theta JA}$. If $V_{CC(\text{est})} \geq V_{CC}(\max)$, then operation between $V_{CC(\text{est})}$ and $V_{CC}(\max)$ is reliable under these conditions.

PACKAGE OUTLINE DRAWINGS

For Reference Only – Not for Tooling Use

(Reference Allegro DWG-0000628, Rev. 1)

NOT TO SCALE

Dimensions in millimeters

Dimensions exclusive of mold flash, gate burrs, and dambar protrusions
Exact case and lead configuration at supplier discretion within limits shown

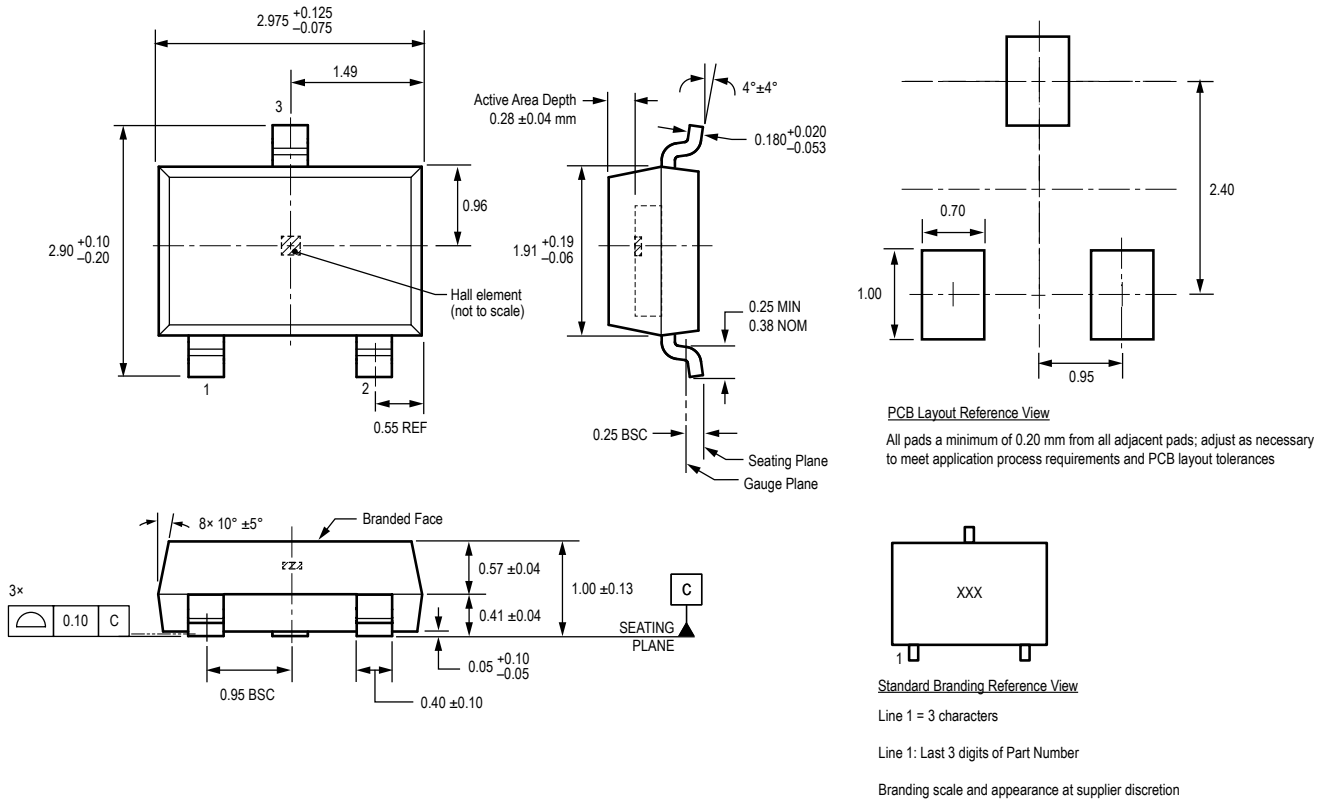

Figure 4: Package LH, 3-Pin SOT23W

For Reference Only – Not For Tooling Use

(Reference DWG-0000404, Rev. 1)
 NOT TO SCALE
 Dimensions in millimeters
 Exact case and lead configuration at supplier discretion within limits shown

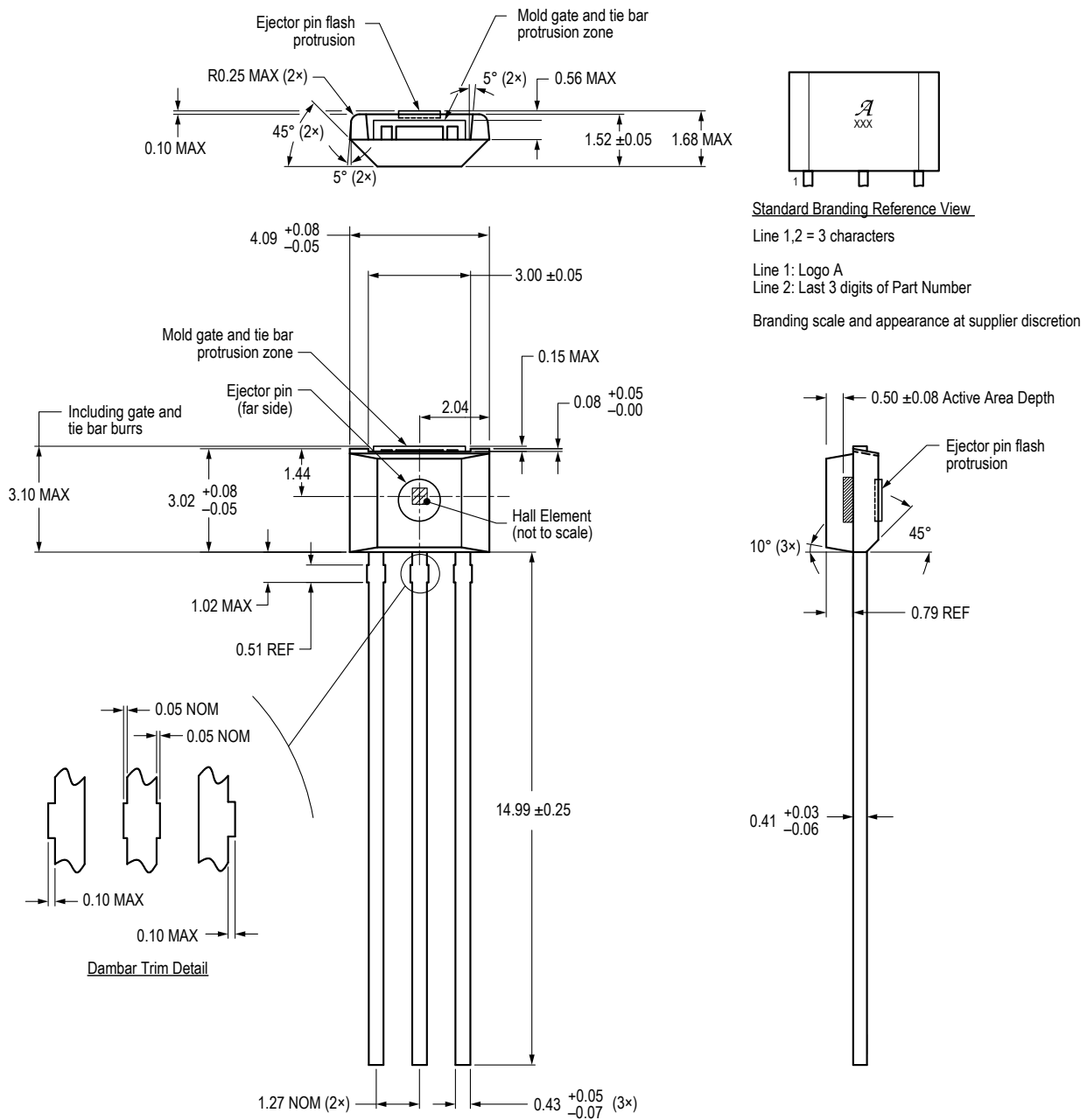

Figure 5: Package UA, 3-Pin SIP

REVISION HISTORY

Number	Date	Description
–	December 17, 2014	Initial Release
1	July 13, 2015	Corrected LH package Active Area Depth value
2	October 30, 2017	Added compliance for 175°C junction temperature operation; updated Absolute Maximums table, and Power Derating section.
3	November 16, 2018	Minor editorial updates
4	January 20, 2020	Minor editorial updates
5	January 25, 2022	Updated package drawings (pages 11-12)

Copyright 2022, Allegro MicroSystems.

Allegro MicroSystems reserves the right to make, from time to time, such departures from the detail specifications as may be required to permit improvements in the performance, reliability, or manufacturability of its products. Before placing an order, the user is cautioned to verify that the information being relied upon is current.

Allegro's products are not to be used in any devices or systems, including but not limited to life support devices or systems, in which a failure of Allegro's product can reasonably be expected to cause bodily harm.

The information included herein is believed to be accurate and reliable. However, Allegro MicroSystems assumes no responsibility for its use; nor for any infringement of patents or other rights of third parties which may result from its use.



Copies of this document are considered uncontrolled documents.

For the latest version of this document, visit our website:

www.allegromicro.com

Looking for pricing, stock, or lifecycle information?

Click below to explore more details on WIN SOURCE:

-  [View A1245LLHLT-I1-T on WIN SOURCE](#)
-  [Allegro MicroSystems, LLC Information](#)

Optimize Your Supply Chain with WIN SOURCE Solutions

-  Global Sourcing Solution
-  Obsolete Management
-  Cost Control Management
-  Shortage Management
-  Alternative Solution
-  Excess Inventory Management