



**THE DATASHEET OF
A4960SJPTR-T**



Automotive, Sensorless BLDC Controller

Features and Benefits

- 3-phase BLDC sensorless start-up and commutation
- Gate drive for N-channel MOSFETs
- Integrated PWM current limit
- 7 to 50 V supply voltage operating range
- Compatible with 3.3 V and 5 V logic
- Cross-conduction protection with adjustable dead time
- Charge pump for low supply voltage operation
- Extensive diagnostics output
- Low current sleep mode

Applications:

- Hydraulic pump
- Fuel pump
- Urea pump
- Blower fan

Package: 32-pin LQFP with exposed thermal pad (suffix JP)

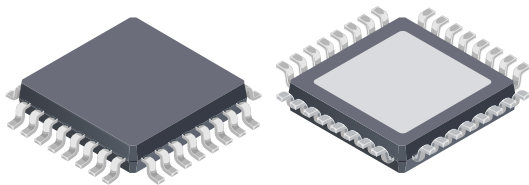

Not to scale

Description

The A4960 is a three-phase, sensorless, brushless DC (BLDC) motor controller for use with external N-channel power MOSFETs and is specifically designed for automotive applications.

The motor is driven using block commutation (trapezoidal drive) where phase commutation is determined, without the need for independent position sensors, by monitoring the motor back-EMF. A programmable motor start-up scheme allows the A4960 to be adjusted for a wide range of motor and load combinations.

An external bootstrap capacitor is used to provide the above battery supply voltage required for N-channel MOSFETs. An automatic internal bootstrap charge management scheme ensures that the bootstrap capacitor is always sufficiently charged for safe operation of the power MOSFETs. The power MOSFETs are protected from shoot-through by integrated crossover control and adjustable dead time.

Integrated diagnostics provide indication of undervoltage, overtemperature, and power bridge faults and can be configured to protect the power MOSFETs under most short circuit conditions. Detailed diagnostics are available as a serial data word.

The A4960 is supplied in a 32-pin LQFP with exposed pad for enhanced thermal dissipation (suffix JP). This package is lead (Pb) free, with 100% matte-tin leadframe plating (suffix -T).

Typical Application

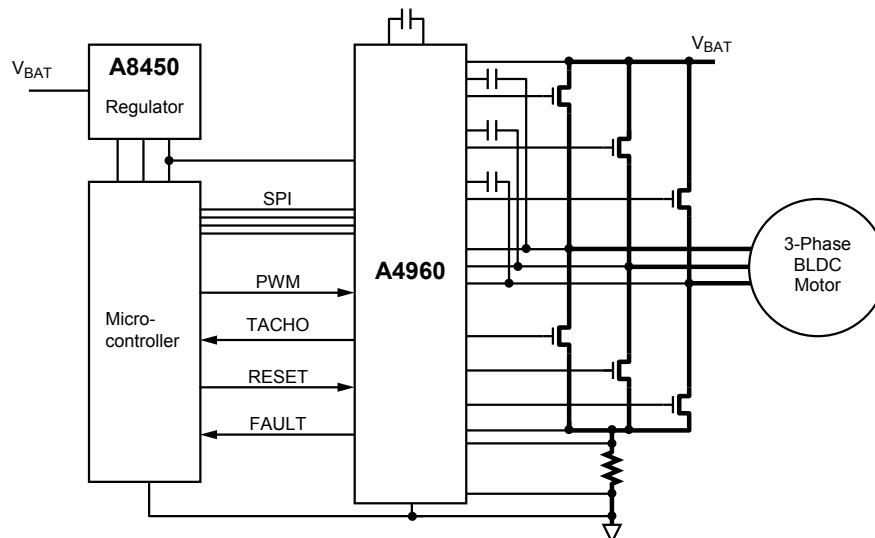

Selection Guide

Part Number	Packing ¹
A4960KJPTR-A-T ²	1500 pieces per 13-in. reel

¹Contact Allegro™ for additional packing options

²The "-A" suffix indicates this is an enhanced EMC performance version.

Absolute Maximum Ratings^{1,2}

Characteristic	Symbol	Notes	Rating	Unit
Load Supply Voltage	V_{BB}		-0.3 to 50	V
Logic Supply Voltage	V_{DD}		-0.3 to 6	V
Terminal VREG	V_{REG}		-0.3 to 16	V
Terminal CP1	V_{CP1}		-0.3 to 16	V
Terminal CP2	V_{CP2}		$V_{CP1} - 0.3$ to $V_{REG} + 0.3$	V
Logic Inputs	V_I	Terminals STRN, SCK, SDI, PWM	-0.3 to 6	V
		Terminal RESETN – can be pulled to V_{BB} with >22 k Ω	-0.3 to 6	V
Logic Outputs	V_O	Terminals SDO, TACHO	-0.3 to $V_{DD} + 0.3$	V
Terminal DIAG	V_{DIAG}		-0.3 to $V_{DD} + 0.3$	V
Terminal VBRG	V_{BRG}		-5 to 55	V
Terminals CA, CB, CC	V_{Cx}		-0.3 to $V_{REG} + 50$	V
Terminals GHA, GHB, GHC	V_{GHx}		$V_{Cx} - 16$ to $V_{Cx} + 0.3$	V
Terminals SA, SB, SC	V_{Sx}		$V_{Cx} - 16$ to $V_{Cx} + 0.3$	V
Terminals GLA, GLB, GLC	V_{GLx}		$V_{REG} - 16$ to 18	V
Terminal LSS	V_{LSS}		$V_{REG} - 16$ to 18	V
Terminal REF	V_{REF}		-0.3 to 6.5	V
Terminals CSP, CSM	V_{CSx}		-0.3 to 1	V
Terminal AGND		Connect directly to GND		
Ambient Operating Temperature Range	T_A	Temperature Range K; limited by power dissipation	-40 to 150	°C
Maximum Continuous Junction Temperature	$T_{J(max)}$		150	°C
Transient Junction Temperature	T_{Jt}	Over temperature event not exceeding 10 s, lifetime duration not exceeding 10 hours, guaranteed by design characterization.	175	°C
Storage Temperature Range	T_{stg}		-55 to 150	°C

¹With respect to GND. Ratings apply when no other circuit operating constraints are present.

²Small "x" in pin names and symbols indicates a variable sequence character.

Thermal Characteristics may require derating at maximum conditions, see application information

Characteristic	Symbol	Test Conditions*	Value	Unit
Package Thermal Resistance, Junction to Ambient	$R_{\theta JA}$	On 4-layer PCB based on JEDEC standard	23	°C/W
		On 2-layer PCB with 3 in. ² copper each side	44	°C/W
Package Thermal Resistance, Junction to Pad	$R_{\theta JP}$		2	°C/W

*Additional thermal information available on the Allegro website

Table of Contents

Specifications	2	Current Limit	18
Pin-out Diagram and Terminal List	4	Current sense amplifier	18
Functional Block Diagram	5	Fixed off-time	18
Electrical Characteristics Table	6	Blank time	19
Timing Diagrams	10	Diagnostics	19
Operation Timing Diagrams	10	DIAG pin	19
Functional Description	12	Serial interface fault output	19
Functional Description	12	Fault response action	20
Input and Output Terminal Functions	12	Fault Mask register	20
Motor Drive System	13	Chip-level diagnostics	20
Rotor position sensing using motor BEMF	13	Chip Fault States: Temperature Thresholds	20
Commutation Blank Time	14	Chip Fault State : VREG Undervoltage	21
BEMF Window	14	Chip Fault State: VDD Undervoltage	21
BEMF Hysteresis	14	Bootstrap Undervoltage Fault State	21
Start-up	14	MOSFET fault detection	21
Motor control	15	MOSFET fault blank time	22
Phase advance	15	Short fault operation	22
Power Supplies	16	MOSFET Fault State: Short to Supply	22
Gate Drives	16	MOSFET Fault State: Short to Ground	22
Gate drive voltage regulation	16	MOSFET Fault State: Shorted Winding	22
Bootstrap charge management	16	Serial Interface Description	23
Low-side gate drive	17	Configuration and control registers	24
High-side gate drive	17	Diagnostic register	25
Dead Time	17	Applications Information	31
Sleep Mode and RESETN	17	Control Timing Diagrams	31
		Input/Output Structures	32
		Package Outline Drawing	33

Pin-out Diagram

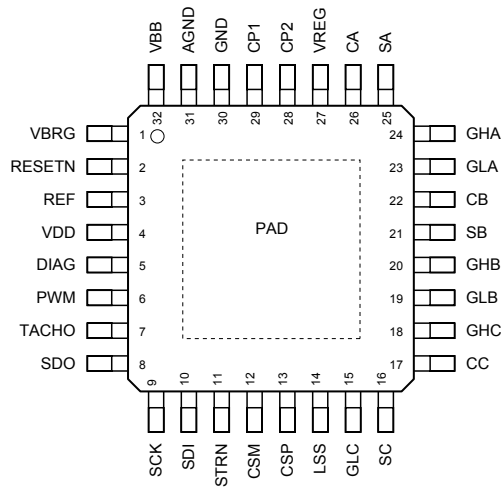

Terminal List Table

Name	Number	Function	Name	Number	Function
AGND	31	Reference ground	LSS	14	Low-side source
CA	26	Bootstrap capacitor, Phase A	PAD	–	Exposed thermal pad
CB	22	Bootstrap capacitor, Phase B	PWM	6	PWM Input
CC	17	Bootstrap capacitor, Phase C	REF	3	Reference voltage input
CP1	29	Pump capacitor	RESETN	2	Standby mode control
CP2	28	Pump capacitor	SA	25	Motor connection, Phase A
CSM	12	Sense amplifier negative input	SB	21	Motor connection, Phase B
CSP	13	Sense amplifier positive input	SC	16	Motor connection, Phase C
DIAG	5	Programmable diagnostic output	SCK	9	Serial clock input
GHA	24	High-side gate drive, Phase A	SDI	10	Serial data input
GHB	20	High-side gate drive, Phase B	SDO	8	Serial data output
GHC	18	High-side gate drive, Phase C	STRN	11	Serial Strobe (chip select) input
GLA	23	Low-side gate drive, Phase A	TACHO	7	Speed output
GLB	19	Low-side gate drive, Phase B	VBB	32	Main power supply
GLC	15	Low-side gate drive, Phase C	VBRG	1	High-side drain voltage sense
GND	30	Power ground	VDD	4	Logic supply
			VREG	27	Regulated voltage, above supply

Functional Block Diagram

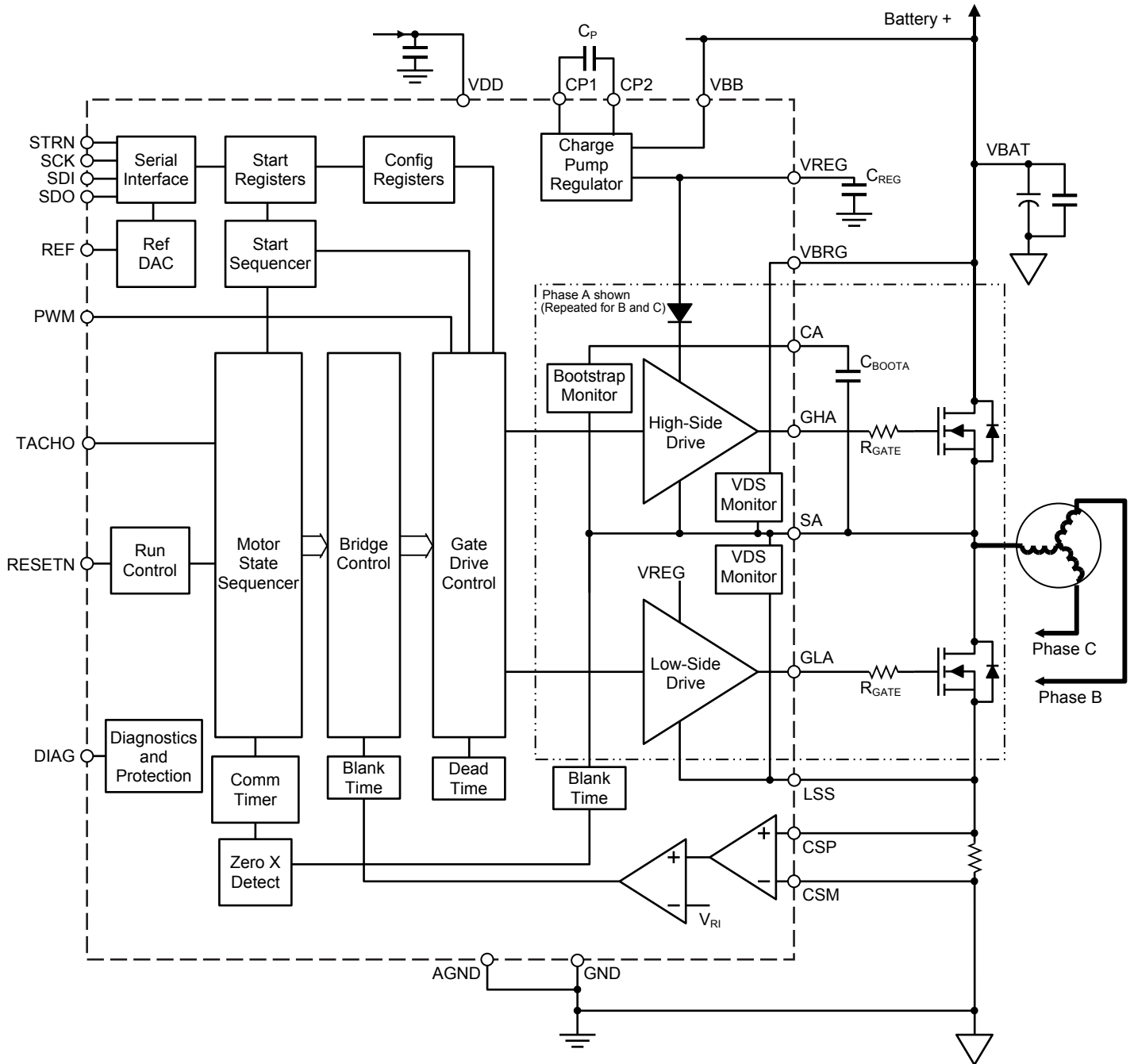

ELECTRICAL CHARACTERISTICS Valid at $T_J = -40^{\circ}\text{C}$ to 150°C , $V_{DD} = 5\text{ V}$, $V_{BB} = 7$ to 28 V ; unless otherwise specified

Characteristics	Symbol	Test Conditions	Min.	Typ.	Max.	Unit
Supply and Reference						
VBB Functional Operating Range ¹	V_{BB}	Operating, outputs active	6	–	50	V
		Operating, outputs disabled	5.5	–	50	V
		No unsafe states	0	–	50	V
VBB Quiescent Current	I_{BBQ}	RESETN = high; GHx, GLx = low, $V_{BB} = 12\text{ V}$	–	10	14	mA
	I_{BBS}	RESETN = low, sleep mode, $V_{BB} = 12\text{ V}$	–	–	10	μA
VDD Logic Supply	V_{DD}		3.0	–	5.5	V
VDD Quiescent Current	I_{DDQ}	RESETN = high, outputs low	–	6	16	mA
	I_{DDS}	RESETN = low	–	–	15	μA
VREG Output Voltage	V_{REG}	$V_{BB} > 9\text{ V}$, $I_{REG} = 0$ to 8 mA	12.4	13	13.8	V
		$7.5\text{ V} < V_{BB} \leq 9\text{ V}$, $I_{REG} = 0$ to 6 mA	12.4	13	13.8	V
		$6\text{ V} < V_{BB} \leq 7.5\text{ V}$, $I_{REG} = 0$ to 5 mA	$2 \times V_{BB} - 2.5$	–	–	V
		$5.5\text{ V} < V_{BB} \leq 6\text{ V}$, $I_{REG} < 4\text{ mA}$	9	10	–	V
Bootstrap Diode Forward Voltage	V_{fBOOT}	$I_D = 10\text{ mA}$	0.4	0.7	1.0	V
		$I_D = 100\text{ mA}$	1.5	2.2	2.8	V
Bootstrap Diode Resistance	r_D	$r_{D(100\text{mA})} = (V_{fBOOT(150\text{mA})} - V_{fBOOT(50\text{mA})}) / 100\text{ (mA)}$	6.5	15.0	22.5	Ω
Bootstrap Diode Current Limit	I_{DBOOT}		250	500	750	mA
System Clock Period	t_{OSC}		42.5	50	57.5	ns
Gate Output Drive						
Turn-On Time	t_r	$C_{LOAD} = 500\text{ pF}$, 20% to 80%	–	35	–	ns
Turn-Off Time	t_f	$C_{LOAD} = 500\text{ pF}$, 80% to 20%	–	20	–	ns
Pull-Up On-Resistance ²	$R_{DS(on)UP}$	$T_J = 25^{\circ}\text{C}$, $I_{GHx} = -150\text{ mA}$	9	13	17	Ω
		$T_J = 150^{\circ}\text{C}$, $I_{GHx} = -150\text{ mA}$	16	21	27	Ω
Pull-Down On-Resistance	$R_{DS(on)DN}$	$T_J = 25^{\circ}\text{C}$, $I_{GLx} = 150\text{ mA}$	1.8	3.0	5.0	Ω
		$T_J = 150^{\circ}\text{C}$, $I_{GLx} = 150\text{ mA}$	2.8	4.5	7.0	Ω
GHx Output Voltage High	V_{GHH}	Bootstrap capacitor fully charged	$V_C - 0.2$	–	–	V
GHx Output Voltage Low	V_{GHL}	$-10\text{ }\mu\text{A} < I_{GH} < 10\text{ }\mu\text{A}$	–	–	$V_{Sx} + 0.3$	V
GLx Output Voltage High	V_{GLH}	$-10\text{ }\mu\text{A} < I_{GL} < 10\text{ }\mu\text{A}$	$V_{REG} - 0.2$	–	–	V
GLx Output Voltage Low	V_{GLL}	$-10\text{ }\mu\text{A} < I_{GL} < 10\text{ }\mu\text{A}$	–	–	$V_{LSS} + 0.3$	V
GHx Passive Pull-Down	R_{GHPD}	$V_{GSH} = 1\text{ V}$	–	350	–	k Ω
GLx Passive Pull-Down	R_{GLPD}	$V_{GSL} = 1\text{ V}$	–	350	–	k Ω
Turn-Off Propagation Delay	$t_{P(off)}$	Input change to unloaded gate output change, see figure 3	200	250	300	ns
Turn-On Propagation Delay	$t_{P(on)}$	Input change to unloaded gate output change, see figure 3	200	250	300	ns
Dead Time (Turn-Off to Turn-On delay)	t_{DEAD}	Default power-up state, see figure 3	0.85	1.0	1.15	μs

Continued on the next page...

ELECTRICAL CHARACTERISTICS (continued) Valid at $T_J = -40^{\circ}\text{C}$ to 150°C , $V_{DD} = 5\text{ V}$, $V_{BB} = 7$ to 28 V ;
unless otherwise specified

Characteristics	Symbol	Test Conditions	Min.	Typ.	Max.	Unit
Current Limiting						
Differential Input Voltage	V_{ID}	$V_{ID} = V_{CSP} - V_{CSM}$	0	–	200	mV
Reference Input Voltage	V_{REF}		0.8	–	2.0	V
Reference Clamp Voltage	V_{REFC}	REF tied to VDD	1.84	2	2.16	V
Reference Input Current ²	I_{REF}		–3	0	3	μA
Internal Reference Voltage	V_{RI}	Default power-up state	–	V_{REF}	–	V
Current Trip Point Error ³	E_{ITRIP}	$V_{REF} = 2\text{ V}$	–5%	–	+5%	%FS
Fixed Off-Time	t_{OFF}	Default power-up state	30.3	35.6	40.9	μs
Blank Time	t_{BL}	Default power-up state	2.72	3.2	3.68	μs
Logic Inputs and Outputs						
Input Low Voltage	V_{IL}	Terminals PWM, SDI, SCK, STRN	–	–	$0.3V_{DD}$	V
		Terminal RESETN	–	–	$0.25V_{DD}$	V
Input High Voltage	V_{IH}		$0.7V_{DD}$	–	–	V
Input Hysteresis	V_{Ihys}	Terminals PWM, SDI, SCK, STRN	150	550	–	mV
		Terminal RESETN	150	370	–	mV
Input Pull-Down Resistor	R_{PD}	Terminals PWM, SDI, SCK	30	50	80	$\text{k}\Omega$
		Terminal RESETN	45	80	110	$\text{k}\Omega$
Input Pull-Up Resistor	R_{PU}	Terminal STRN	30	50	80	$\text{k}\Omega$
Output Low Voltage	V_{OL}	$I_{OL} = 1\text{ mA}$	–	0.2	0.4	V
Output High Voltage ²	V_{OH}	$I_{OL} = -1\text{ mA}$	$V_{DD} - 0.4$	$V_{DD} - 0.2$	–	V
Output Leakage (SDO) ²	I_O	$0\text{ V} < V_O < V_{DD}$, STRN = 1	–1	–	1	μA
Logic Inputs and Outputs – Dynamic Parameters						
RESETN Pulse Width	t_{RES}		0.2	–	4.5	μs
RESETN Shutdown Width	t_{RSD}		10	–	–	μs
Input Pulse Filter Time (PWM)	t_{PIN}		–	35	–	ns
PWM Brake Time	t_{BRK}		500	–	–	μs
Clock High Time	t_{SCKH}	A in figure 1	50	–	–	ns
Clock Low Time	t_{SCKL}	B in figure 1	50	–	–	ns
Strobe Lead Time	t_{STLD}	C in figure 1	30	–	–	ns
Strobe Lag Time	t_{STLG}	D in figure 1	30	–	–	ns
Strobe High Time	t_{STRH}	E in figure 1	300	–	–	ns
Data Out Enable Time	t_{SDOE}	F in figure 1	–	–	40	ns
Data Out Disable Time	t_{SDOD}	G in figure 1	–	–	30	ns
Data Out Valid Time from Clock Falling	t_{SDOV}	H in figure 1	–	–	40	ns
Data Out Hold Time from Clock Falling	t_{SDOH}	I in figure 1	5	–	–	ns

Continued on the next page...

ELECTRICAL CHARACTERISTICS (continued) Valid at $T_J = -40^\circ\text{C}$ to 150°C , $V_{DD} = 5\text{ V}$, $V_{BB} = 7$ to 28 V ;
unless otherwise specified

Characteristics	Symbol	Test Conditions	Min.	Typ.	Max.	Unit
Logic I/O – Dynamic Parameters (continued)						
Data In Set-up Time to Clock Rising	t_{SDIS}	J in figure 1	15	–	–	ns
Data In Hold Time from Clock Rising	t_{SDIH}	K in figure 1	10	–	–	ns
Wake Up from Sleep Mode	t_{EN}	RESETN rising to undervoltage faults cleared	–	–	2	ms
Motor Start-up Parameters						
Hold Torque Internal Reference	V_{HQ}	Default power-up level: $I_{DS} = 0$	33.7	37.5	41.3	$\%V_{REF}$
Hold Torque Duty Cycle	D_{HQ}	Default power-up level: $I_{DS} = 1$	33.7	37.5	41.3	%
Hold Time	t_{HOLD}	Default power-up level	28.9	34.0	39.1	ms
Start Commutation Time	t_{COMS}	Default power-up level	34	40	46	ms
End Commutation Time	t_{COME}	Default power-up level	2.72	3.20	3.68	ms
Ramp Torque Internal Reference	V_{RQ}	Default power-up level: $I_{DS} = 0$	50.6	56.25	61.9	$\%V_{REF}$
Ramp Torque Duty Cycle	D_{RQ}	Default power-up level: $I_{DS} = 1$	50.6	56.25	61.9	%
Ramp Rate (Change in commutation time)	Δt_{COM}	RR[3:0] = 1001	1.7	2.0	2.3	ms
Motor Run Parameters						
Phase Advance	θ_{ADV}	Denominated in electrical degrees, PA[3:0] = 1000	12	15	18	deg
BEMF Hysteresis – High	V_{BHYSH}		–	240	–	mV
BEMF Hysteresis – Low	V_{BHYSL}		–	60	–	mV
BEMF Window Time	t_{BW}	Default power-up level	5.4	6.4	7.4	μs
Commutation Blank Time	t_{CB}	Default power-up level	42.5	50	57.5	μs
Protection						
VREG Undervoltage Threshold	$V_{REGUVON}$	V_{REG} rising	7.5	8	8.5	V
	$V_{REGUVOFF}$	V_{REG} falling	6.6	7.1	7.6	V
Bootstrap Undervoltage	V_{BOOTUV}	V_{BOOT} falling, $V_{Cx} - V_{Sx}$	58	–	71	$\%V_{REG}$
Bootstrap Undervoltage Hysteresis	$V_{BOOTUVHys}$		–	13	–	$\%V_{REG}$
VDD Undervoltage Threshold	V_{DDUV}	V_{DD} falling	2.45	2.7	2.85	V
VDD Undervoltage Hysteresis	$V_{DDUVHys}$		50	100	150	mV
Drain-Source Threshold Voltage	V_{DSTH}	Default power-up level	720	800	880	mV
VBRG Input Voltage	V_{BRG}	When VDS monitor is active	$V_{BB} - 1$	V_{BB}	$V_{BB} + 1$	V
VBRG Input Current	I_{VBRG}	$V_{DSTH} = \text{default}$, $V_{BB} = 12\text{ V}$, $0\text{ V} < V_{BRG} < V_{BB}$	–	–	250	μA
Short-to-Ground Threshold Offset ⁴	V_{STGO}	High side on, $V_{DSTH} \geq 1\text{ V}$	–	± 100	–	mV
		High side on, $V_{DSTH} < 1\text{ V}$	–150	± 50	+150	mV
Short-to-Battery Threshold Offset ⁵	V_{STBO}	Low side on, $V_{DSTH} \geq 1\text{ V}$	–	± 100	–	mV
		Low side on, $V_{DSTH} < 1\text{ V}$	–150	± 50	+150	mV

Continued on the next page...

ELECTRICAL CHARACTERISTICS (continued) Valid at $T_J = -40^\circ\text{C}$ to 150°C , $V_{DD} = 5\text{ V}$, $V_{BB} = 7$ to 28 V ;
unless otherwise specified

Characteristics	Symbol	Test Conditions	Min.	Typ.	Max.	Unit
Protection (continued)						
DIAG Output Clock Division Ratio	N_D	DGx = 01	400	–	–	–
DIAG Output V_{DS} Threshold Error	$E_{V_{THD}}$	DGx = 10	–10	–	10	mV
Temperature Warning Threshold	T_{JW}	Temperature increasing	125	135	145	$^\circ\text{C}$
Temperature Warning Hysteresis	T_{JWHys}		–	15	–	$^\circ\text{C}$
Overtemperature Threshold	T_{JF}	Temperature increasing	155	170	–	$^\circ\text{C}$
Overtemperature Hysteresis	T_{JFHys}	Recovery = $T_{JF} - T_{JHys}$	–	15	–	$^\circ\text{C}$

¹Function is correct but parameters are not guaranteed above or below the general limits (7 to 28 V).

²For input and output current specifications, negative current is defined as coming out of (sourcing) the specified device terminal.

³Current Trip Point Error is the difference between the actual current trip point and the target current trip point, referred to maximum full scale (100%)

current: $E_{ITRIP} = 100 \times (I_{TRIP(Actual)} - I_{TRIP(Target)}) / I_{FullScale} (\%)$.

⁴As V_{Sx} decreases, a fault occurs if $V_{BAT} - V_{Sx} > V_{STG}$. STG threshold, $V_{STG} = V_{DTSTH} + V_{STGOFF}$.

⁵As V_{Sx} increases, a fault occurs if $V_{Sx} - V_{LSS} > V_{STB}$. STB threshold, $V_{STB} = V_{DTSTH} + V_{STBOFF}$.

Operation Timing Diagrams

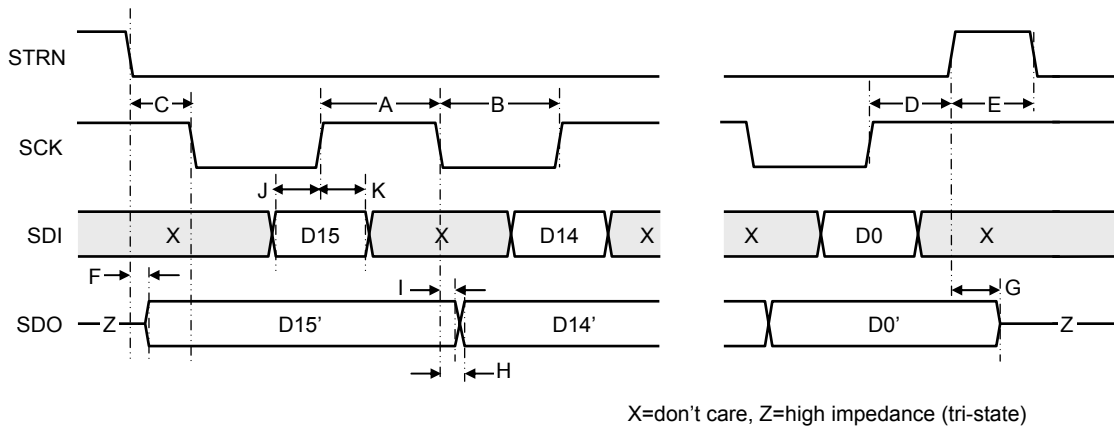

X=don't care, Z=high impedance (tri-state)

Figure 1. Serial Interface Timing (letters A through K are referenced in the Electrical Characteristics table, Logic Inputs and Outputs – Dynamic Parameters section)

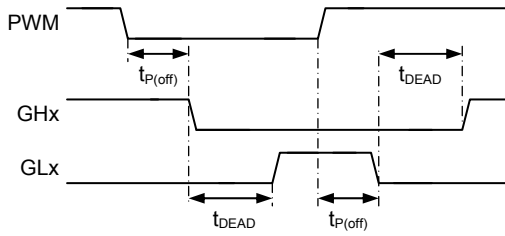

Figure 2. Gate Drive Output Timing – PWM Input

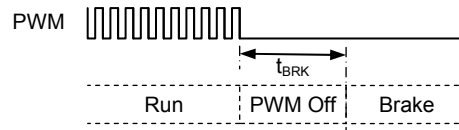

Figure 3. PWM Brake Timing

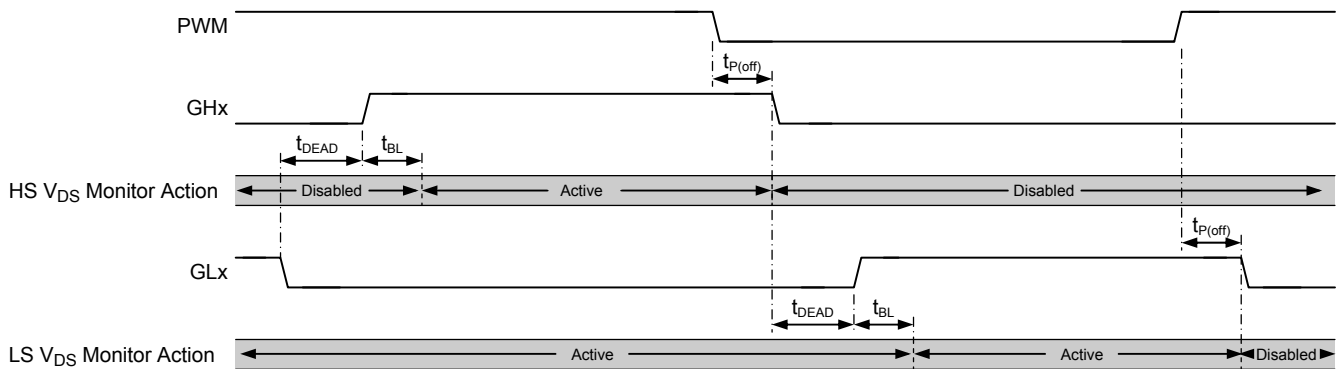

Figure 4. V_{DS} Fault Blanking

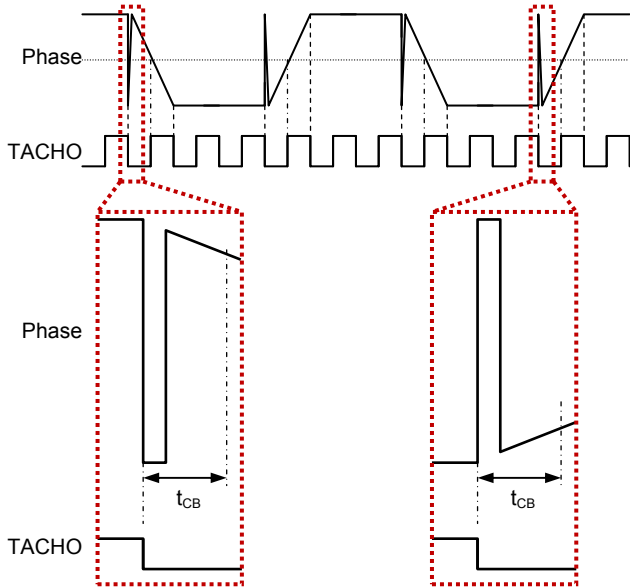

Figure 5. Commutation Blank Time

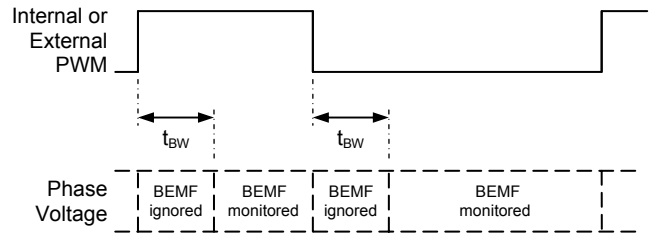

Figure 6. BEMF Window

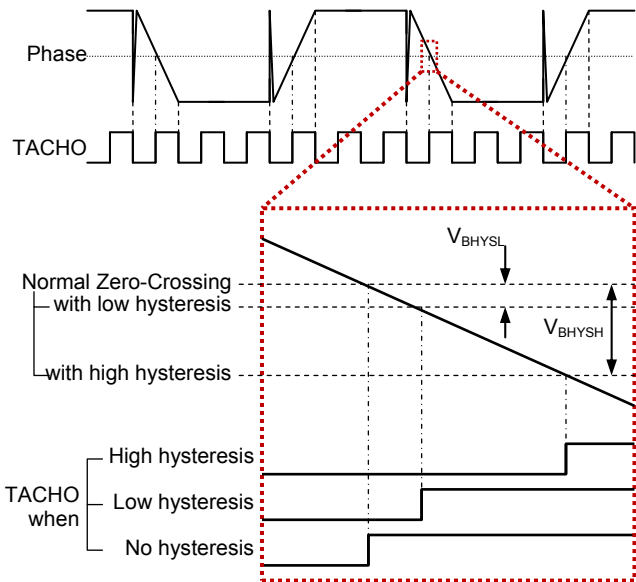

Figure 7. BEMF Hysteresis – Falling Phase Voltage

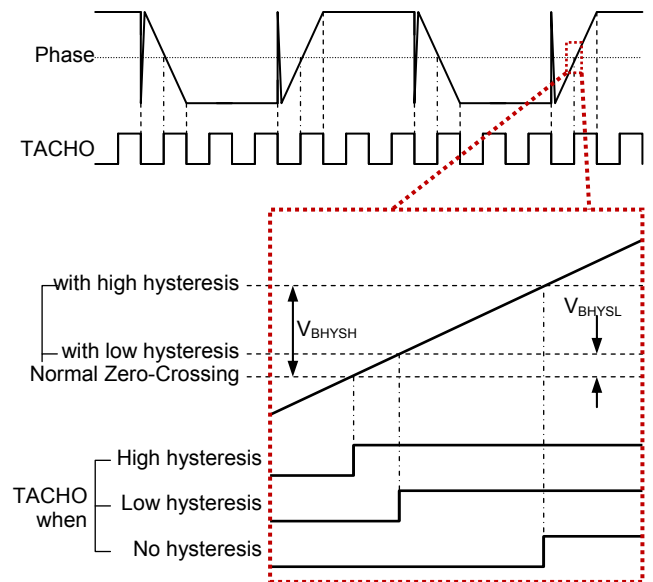

Figure 8. BEMF Hysteresis – Rising Phase Voltage

Functional Description

The A4960 is a three-phase, sensorless, brushless DC (BLDC) motor controller for use with external N-channel power MOSFETs and is specifically designed for automotive applications. The motor is driven using block commutation (trapezoidal drive), where phase commutation is determined by a proprietary, motor back-EMF (BEMF) sensing technique. The motor BEMF is sensed to determine the rotor position without any requirement for independent position sensors.

Motor current is provided by six external N-channel power MOSFETs arranged as a three-phase bridge. The A4960 provides six high current gate drives, three high-side and three low-side, capable of driving a wide range of MOSFETs. It includes all the necessary circuits to ensure that the gate-source voltage of both high-side and low-side MOSFETs are above 10 V at motor supply voltages down to 7 V.

An integrated start-up scheme can be configured with programmable parameters through a serial interface allowing the A4960 to be adjusted for a wide range of motor and load combinations. The serial interface also provides the ability to program various gate drive and diagnostic parameters.

Integrated diagnostics provide indication of undervoltage, over-temperature, and power bridge faults. They can be configured to protect the power MOSFETs under most short circuit conditions. Detailed diagnostic information is available through the serial interface.

Specific functions are described more fully in following sections.

Input and Output Terminal Functions

VBB Main power supply for internal regulators and charge pump. The main power supply should be connected to VBB through a reverse voltage protection circuit and should be decoupled with ceramic capacitors connected close to the supply and ground terminals.

VDD Logic supply. Compatible with 3.3 V and 5 V logic. This should be decoupled to ground with a 100 nF capacitor.

CP1, CP2 Pump capacitor connections for charge pump. Connect a 220 nF ceramic capacitor between CP1 and CP2.

VREG Regulated voltage, nominally 13 V, used to supply the low side gate drivers and to charge the bootstrap capacitors. A sufficiently large storage capacitor must be connected to this terminal

to provide the transient charging current.

REF Voltage reference input to internal reference DAC. Connect to VDD to use the internal 2 V reference.

GND Analog reference, digital and power ground. Connect to supply ground.

VB RG Sense input to the top of the external MOSFET bridge. Allows accurate measurement of the voltage at the drain of the high-side MOSFETs.

CA, CB, CC High-side connections for the bootstrap capacitors and positive supply for high-side gate drivers.

GHA, GHB, GHC High-side, gate-drive outputs for external N-channel MOSFETs.

SA, SB, SC Motor phase connections. These terminals sense the voltages switched across the load. They are also connected to the negative side of the bootstrap capacitors and are the negative supply connections for the floating high-side drivers.

GLA, GLB, GLC Low-side, gate-drive outputs for external N-channel MOSFETs.

LSS Low-side return path for discharge of the capacitance on the MOSFET gates, connected to the common sources of the low-side external MOSFETs through a low impedance track.

CSP, CSM Current sense amplifier inputs. Connect directly to each end of the sense resistor using separate PCB traces.

PWM PWM input to control high-side switching. When pulsed low, this turns off any active high-side drivers and turns on the complementary low-side drivers. When held low for longer than the PWM brake time, this turns off all high-side drivers and turns on all low-side drivers, when RUN (bit 0 in the Run register) is set to 1.

RESETN Resets faults when pulsed low. Forces low-power shutdown (sleep mode) when held low for more than the reset shutdown width, t_{RSD} . Can be pulled to VBB with 22 k Ω resistor.

SDI Serial data input. 16-bit serial word input, MSB first.

SDO Serial data output. High impedance when STRN is high. Outputs FF (bit 15 of the Diagnostic register), the Fault flag, as soon as STRN goes low.

SCK Serial clock. Data is latched in from SDI on the rising edge of SCK. There must be 16 rising edges per write and SCK must be held high when STRN changes.

STRN Serial data strobe and serial access enable. When STRN is high any activity on SCK or SDI is ignored, and SDO is high impedance allowing multiple SDI slaves to have common SDI, SCK, and SDO connections.

DIAG Diagnostic output. Programmable output to provide four alternative functions: Fault output flag (default), Sensorless Operation Indicator, internal timer, and V_{DS} threshold.

TACHO Motor speed output. Provides a pulse signal with a frequency proportional to the motor speed. TACHO remains low until the first BEMF zero-crossing is detected.

Motor Drive System

The motor drive system consists of three half bridge gate drive outputs, each driving one leg of an external 3-phase MOSFET power bridge. The state of the gate drive outputs is determined by a state sequencer with six possible states. These states are shown in table 1 and change in a set sequence depending on the required direction of rotation. For the A4960, *forward* is defined as the state sequence shown in table 1, DIR (Run bit 1) set to 0, incrementing in steps of one from 1 to 6, then repeating from 1. *Reverse* (DIR set to 1) is decrementing in steps of one from 6 to 1, then repeating from 6. The effect of these states on the motor phase voltage is illustrated in figure 11. The point at which the state of the gate outputs changes is defined as the *commutation point* and must occur each time the magnetic poles of the rotor reach a specific point in relation to the poles of the stator. This point is determined by a complete self contained BEMF sensing scheme with an adaptive commutation timer.

Rotor position sensing using motor BEMF

Determining the rotor position using BEMF sensing relies on the accurate comparison of the voltage on the undriven (tri-state) motor phase (indicated by Z in table 1) to the voltage at the centertap of the motor, approximated using a reference voltage at half the supply voltage. The BEMF zero crossing, the point where the tri-stated motor winding voltage crosses the reference voltage, is used as a positional reference. When the motor is running at a constant speed, this zero crossing occurs approximately halfway through one commutation cycle. Adaptive commutation circuitry and programmable timers then determine the optimal commutation points.

Zero crossings are indicated by the output at the TACHO terminal, which goes high at each valid zero crossing and low at the next commutation point, as shown in figure 9. In each state, the BEMF detector looks for the first correct polarity (low-to-high

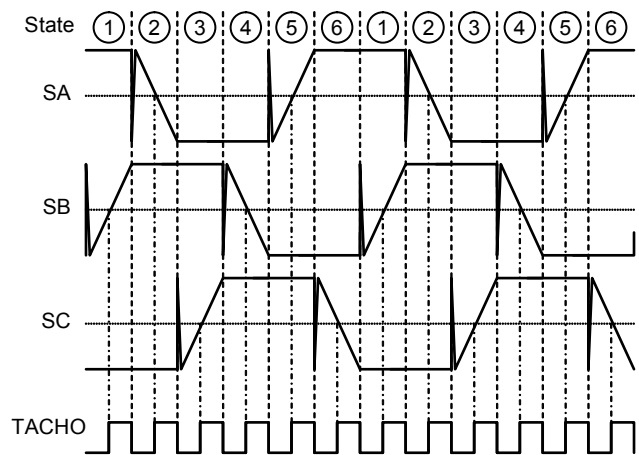

Figure 9. Motor phase state sequence, DIR = 0

Table 1. Control and Phase Sequence Table

Control Bits				State	Motor Phase			Gate Drive Outputs						Mode
RUN	BRK	DIR = 1	DIR = 0		SA	SB	SC	GHA	GLA	GHB	GLB	GHC	GLC	
1	0	↑	↓	1	HI	Z	LO	HI	LO	LO	LO	LO	HI	Run
1	0			2	Z	HI	LO	LO	LO	HI	LO	LO	HI	
1	0			3	LO	HI	Z	LO	HI	HI	LO	LO	LO	
1	0			4	LO	Z	HI	LO	HI	LO	LO	HI	LO	
1	0			5	Z	LO	HI	LO	LO	LO	HI	HI	LO	
1	0			6	HI	LO	Z	HI	LO	LO	HI	LO	LO	
0	x	x	x	x	Z	Z	Z	LO	LO	LO	LO	LO	LO	Coast
1	1	x	x	x	LO	LO	LO	LO	HI	LO	HI	LO	HI	Brake

x: don't care; HI: high-side MOSFET active; LO: low-side MOSFET active; Z: high impedance, both MOSFETs off

or high-to-low) zero crossing and latches it until the next state change. This latching action, combined with precise comparator hysteresis, provides a robust sensing system.

There are three variables that effect the BEMF sensing, these are:

- Commutation Blank Time, t_{CB}
- BEMF Hysteresis, V_{BHYS}
- BEMF Window, t_{BW}

Commutation Blank Time

The BEMF detectors are inhibited for t_{CB} following a commutation event. This prevents any commutation transients and winding demagnetization periods from disturbing the BEMF sensing system. The commutation blank time is shown in figure 5 and is selected by CB[1:0] (Config0 bits 11:10).

BEMF Window

The BEMF window is the length of time after any PWM change, low-to-high or high-to-low, during which the phase voltage and the output of the BEMF comparator is ignored, as shown in figure 6. It is selected using BW[2:0] (Run bits 9:7). The BEMF window is effectively the BEMF comparator blank time.

If the PWM-on time is less than the BEMF window, then the phase voltage is ignored for the whole PWM-on time. If the PWM-off time is less than the BEMF window, then the phase voltage is ignored for the whole PWM-off time.

BEMF Hysteresis

The BEMF hysteresis is the amount by which the BEMF voltage, measured on the undriven phase, must exceed the normal zero-crossing value before zero crossing is detected and TACHO goes high. This is illustrated in figures 7 and 8.

If the BEMF is falling, then the zero crossing will be detected when the BEMF voltage is lower than the normal zero-crossing value minus the BEMF hysteresis (figure 7).

If the BEMF is rising, then the zero crossing will be detected when the BEMF voltage is higher than the normal zero-crossing value plus BEMF hysteresis (figure 8).

The BEMF hysteresis is selected using BH[1:0] (Run bits 11:10). It can be set to zero, low (typically 60 mV), high (typically 240 mV) or Auto. Auto sets the hysteresis to the high level during start-up and reduces it to the low level during running. This provides added security during start-up in achieving a stable

BEMF detection but permits the motor to run slower or at a lower voltage when BEMF detection is achieved.

Start-up

In order to correctly detect the zero crossing, the changing motor BEMF on any phase must be detectable when that phase is not being driven. When the motor is running at a relatively constant speed, this is ensured by the adaptive commutation scheme used. However, during start-up, particularly when the motor load has a high friction component, the motor must be accelerated from rest in such a way that the BEMF zero crossing can be detected. Initially, as the motor is started, there is no rotor position information from the BEMF sensor circuits and the motor must be driven in an open loop 3-phase stepper mode. Unlike a true stepper motor, which is designed for open loop operation, most 3-phase BLDC motors are unstable when driven in this way and will overshoot the intended step point by a large margin. To overcome this limitation the motor must be accelerated such that the motor movement and the phase step sequence can synchronize to allow correct BEMF zero crossing detection.

The initial start speed, the acceleration rate, and the accelerating torque must be adjusted for each combination of motor and mechanical load. These parameters can be programmed in the A4960 through the serial interface. Configuration registers Config4 and Config5 provide the following programmable parameters:

- Config4 bits SC[3:0] – set the start of ramp speed
- Config4 bits EC[3:0] – set the end of ramp speed
- Config5 bits RR[3:0] – set the ramp rate
- Config5 bits RQ[3:0] – set the acceleration torque

To ensure that the motor start-up and sensorless BEMF capture is consistent, the start sequencer always forces the motor to a known start position. The time during which the motor is forced into the start position can be programmed through the serial interface using the four hold time bits, HT[3:0] (Config3 bits 3:0). The torque applied during this hold time is programmed using the four hold torque bits, HQ[3:0], (Config3 bits 7:4). These two variables allow a stable start condition to be achieved for different motor and attached mechanical loads.

As soon as a valid BEMF zero crossing is detected during the start sequence, the A4960 will transition to full BEMF commutation and the start sequencer will be reset. The TACHO output

will remain low until the first BEMF zero crossing is detected. TACHO will then go high at each BEMF zero crossing and will go low at each commutation point. Sensorless operation is also indicated by a zero in LOS (Diagnostic bit 9), and by a high level when the Sensorless Operation Indicator option is selected on the DIAG pin output.

If sensorless operation cannot be achieved by the end of the acceleration ramp, then the sequencer will reset and retry if RSC (Run bit 3) is set to 1. This will continue until stopped by pulling PWM or RESETN low, or by control via the serial interface. If RSC is set to 0, then the retry will not take place, and the outputs will remain off and the LOS bit will be set.

Motor control

The running state, direction, and speed of the motor are controlled by a combination of commands through the serial interface and by signals on specific terminals (see Applications Information section). The serial interface provides three control bits: RUN, DIR, and BRK (Run bits 2:0).

When RUN is set to 1, the A4960 is allowed to run the motor or to commence the start-up sequence. When RUN is set to 0 all gate drive outputs go low, no commutation takes place, and the motor is allowed to coast. Setting RUN to 0 overrides all other control inputs.

The DIR bit determines the direction of rotation. *Forward* is defined as the state sequence shown in table 1, DIR (Run bit 1) set to 0, incrementing in steps of one from 1 to 6, then repeating from 1. *Reverse* (DIR set to 1) is decrementing in steps of one from 6 to 1, then repeating from 6.

The BRK bit can be set to apply an electrodynamic brake which will decelerate a rotating motor. It also can provide some holding torque for a stationary motor. When RUN and BRK are both set to 1, all low-side MOSFETs will be turned on and all high-side MOSFETs turned off, effectively applying a short between the motor windings. This allows the reverse voltage generated by the rotation of the motor (motor BEMF) to set up a current in the motor phase windings that will produce a braking torque. This braking torque will always oppose the direction of rotation of the motor. The strength of the braking or holding torque will depend on the motor parameters. No commutation takes place during

braking and no current control is available. Care must be taken to ensure that the braking current does not exceed the capability of the low-side MOSFETs.

When RUN is set to 1, automatically LOS (Diagnostic bit 9) is set to 1 and the Sensorless Operation Indicator option on the DIAG pin output, if selected, is set low until sensorless operation is achieved. When RUN is set to 0, or BRK is set to 1, the LOS bit and the Sensorless Operation Indicator are inactive (LOS set to 0 and DIAG set high).

When the motor is running, the motor speed can be varied by applying a variable duty cycle input to the PWM terminal. The motor speed will be proportional to the duty cycle of this signal but will also vary with the mechanical load and the supply voltage. Precise speed control requires an external control loop which can use the PWM input to vary the motor speed within the overall closed loop speed controller. The motor speed can be determined by monitoring the TACHO output. When the A4960 is running with sensorless commutation, the TACHO output provides a square wave output with a frequency proportional to the motor speed.

The PWM input can be driven from 3.3 V or 5 V logic, and has hysteresis and a filter to improve noise performance. When pulsed low, any active high-side drivers will be turned off and the complementary low-side drivers will be turned on. This provides high-side chopped, slow-decay PWM with synchronous rectification.

Holding the PWM input low for longer than the PWM brake time, t_{BRK} , will force a brake condition in the same way as the BRK bit in the Run register. The brake will only be active when RUN is set to 1.

Except for the PWM brake function, the PWM input will be ignored during start-up, until sensorless commutation is achieved. It also will also be ignored when BRK is set to 1.

Phase advance

In some motor control systems, improved motor performance can be achieved by starting to energize the phase windings in advance of the timing defined by the rotor position. This ensures that the phase windings have reached the required current level at the point where the resulting forward torque on the rotor will be most

effective. It also ensures that the current in the phase windings will start to decay in time to ensure that the torque produced by the decaying phase current will not cause any rotor drag. If correctly set up, phase advance can result in greater motor efficiency. In motors that use Hall sensors or rotary decoders this can be achieved by a mechanical offset in the sensor position. However this is only valid for one direction of rotation.

The A4960 overcomes this mechanical limitation by providing a programmable electronic method of setting the phase advance in either direction of rotation. The PA[3:0] (Config5 bits 11:8) setting provides phase advance in electrical commutation angle from 0° to 28° in steps of 1.9°. This is equivalent to a phase advance up to almost half of the commutation period on any one phase. The phase advance is automatically always in relation to the motor direction. There is no need to change the value with a direction change.

Power Supplies

Two power supply voltages are required, one for the logic interface and control, and another one for the analog and output drive sections. The logic supply, connected to VDD, is a 5 V nominal supply, but the TTL threshold logic inputs allow the inputs to be driven from a 3.3 V or 5 V logic interface.

The normal operating voltage range of the A4960, where the electrical parameters are fully defined, is 7 to 28 V. However, it is designed to function correctly up to 50 V during load dump conditions, and will maintain full operation down to 6 V. Below 7 V and above 28 V some parameters may exceed the limits specified for the normal supply voltage range. The A4960 will function correctly with a VBB supply down to 5.5 V. However, full sensorless start-up and commutation may not be possible. This provides a very rugged solution for use in the harsh automotive environment.

The main power supply should be connected to VBB through a reverse voltage protection circuit. Both supplies should be decoupled with ceramic capacitors connected close to the supply and ground terminals.

Gate Drives

The A4960 is designed to drive external, low on-resistance, power N-channel MOSFETs. It supplies the large transient

currents necessary to quickly charge and discharge the external MOSFET gate capacitance in order to reduce dissipation in the MOSFET during switching. The charge current for the high-side drives is provided by the bootstrap capacitors connected between the Cx and Sx terminals, one for each phase. The charge and discharge rate can be controlled using an external resistor in series with the connection to the gate of the MOSFET.

Gate drive voltage regulation

The gate drives are powered by an internal regulator which limits the supply to the drives and therefore the maximum gate voltage. When the VBB supply is greater than approximately 16 V, the regulator is a simple linear regulator. Below 16 V, the regulated supply is maintained by a charge pump boost converter, which requires a pump capacitor connected between the CP1 and CP2 pins. This capacitor must have a minimum value of 220 nF, and is typically 470 nF.

The regulated voltage, nominally 13 V, is available on the VREG pin. A sufficiently large storage capacitor must be connected to this pin to provide the transient charging current to the low-side drives and the bootstrap capacitors.

Bootstrap charge management

The A4960 monitors the individual bootstrap capacitor charge voltages to ensure sufficient high-side drive. Before a high-side drive can be turned on, the bootstrap capacitor voltage must be higher than the turn-on voltage limit. If this is not the case, then the A4960 will attempt to charge the bootstrap capacitor by activating the complementary low-side drive. Under normal circumstances this will charge the capacitor above the turn-on voltage in a few microseconds and the high-side drive will then be enabled. The bootstrap voltage monitor remains active while the high-side drive is active, and if the voltage drops below the turn-off voltage, a charge cycle is initiated also.

The bootstrap charge management circuit may actively charge the bootstrap capacitor regularly when the PWM duty cycle is very high, particularly when the PWM off-time is too short to permit the bootstrap capacitor to become sufficiently charged. If, for any reason, the bootstrap capacitor cannot be sufficiently charged a bootstrap fault will occur. See the Diagnostics section for further details.

Low-side gate drive

The low-side gate drive outputs GLA, GLB, and GLC are referenced to the LSS terminal. These outputs are designed to drive external N-channel power MOSFETs. External resistors between each gate drive output and the gate connection to the respective MOSFET (as close as possible to the MOSFET) can be used to control the slew rate seen at the gate, thereby providing some control of the di/dt and dv/dt of the voltage at the SA, SB, and SC terminals. When GLx is set high, the upper half of the driver is turned on and the drain sources current to the gate of the respective low-side MOSFET in the external power bridge, turning on the MOSFET. When GLx is set low, the lower half of the driver is turned on and the drain sinks current from the external MOSFET gate circuit to the LSS terminal, turning off the MOSFET. LSS is the low-side return path for discharge of the capacitance on the MOSFET gates. It should be connected to the common sources of the low-side external MOSFETs through a low-impedance circuit board trace.

High-side gate drive

The high-side gate drive outputs GHA, GHB and GHC are referenced to the SA, SB, and SC pins respectively. These outputs are designed to drive external N-channel power MOSFETs. External resistors between each gate drive output and the gate connection to the respective MOSFET (as close as possible to the MOSFET) can be used to control the slew rate seen at the gate, thereby controlling the di/dt and dv/dt of the voltage at the SA, SB, and SC terminals. When GHx is set high, the upper half of the driver is turned on and the drain sources current to the gate of the respective high-side MOSFET in the external motor-driving bridge, turning on the MOSFET. When GHx is set low, the lower half of the driver is turned on and the drain sinks current from the external MOSFET gate circuit to the respective Sx terminal, turning off the MOSFET.

The CA, CB, and CC pins are the positive supplies for the floating high-side gate drives. The bootstrap capacitors are connected between the Cx and Sx terminals of the same phase. The bootstrap capacitors are charged to approximately V_{REG} when the associated output Sx terminal is low. When the Sx output swings high, the charge on the bootstrap capacitor causes the voltage at the corresponding Cx terminal to rise with the output to provide the boosted gate voltage needed for the high-side MOSFETs.

The SA, SB, and SC terminals are connected directly to the motor phase connections. These terminals sense the voltages switched

across the load. They are also connected to the negative side of the bootstrap capacitors and are the negative supply connections for the floating high-side drives. The discharge current from the high-side MOSFET gate capacitance flows through these connections which should have low impedance circuit board traces to the MOSFET bridge. These terminals also provide the phase voltage feedback to used to determine the rotor position.

Dead Time

To prevent cross conduction (shoot through) in any phase of the power MOSFET bridge, it is necessary to have a dead-time delay between a high- or low-side turn-off and the next complementary turn-on event. The potential for cross conduction occurs when any complementary high-side and low-side pair of MOSFETs are switched at the same time, for example, at the PWM switchpoints. In the A4960, the dead time for all three phases is set by the contents of DT[5:0] (Config0 bits 5:0). These six bits contain a positive integer that determines the dead time by division from the system clock.

The dead time is defined as:

$$t_{DEAD} = n \times 50 \text{ ns} \quad (1)$$

where n is a positive integer defined by DT[5:0] and t_{DEAD} has a minimum programmable value of 100 ns.

For example, when DT[5:0] contains 011000 (24 in decimal), then $t_{DEAD} = 1.2 \mu\text{s}$ (typical).

The accuracy of t_{DEAD} is determined by the accuracy of the system clock, as defined in the Electrical Characteristics table, t_{OSC} . A DT[5:0] value of 000000, 000001, or 000010 (0, 1, or 2 in decimal) sets the minimum programmable t_{DEAD} of 100 ns.

Sleep Mode and RESETN

RESETN is an active-low input which allows the A4960 to enter sleep mode, in which the current consumption from the VBB and VDD supplies is reduced to its minimum level. When RESETN is held low for longer than the reset pulse time, t_{RES} , the internal pump regulator and all internal circuitry is disabled and the A4960 enters sleep mode. In sleep mode the latched faults and corresponding fault flags are cleared.

When coming out of sleep mode, the protection logic ensures that the gate drive outputs are off until the charge pump reaches

its correct operating condition. The charge pump will stabilize in approximately 3 ms under typical conditions. To allow the A4960 to start-up without requiring external logic input, the RESETN terminal can be pulled to V_{BB} with an external pull-up resistor. The resistor value should be between 20 and 33 k Ω .

RESETN can also be used to clear any fault conditions without entering sleep mode by taking it low for the reset pulse time, t_{RES} . Latched short fault conditions, which disable the outputs, will be cleared as will the serial fault register.

Current Limit

An integrated fixed off-time PWM current control circuit is provided to limit the motor current during periods when the torque demand exceeds the normal operating range. It is also available at start-up to set the hold torque and the ramp torque if IDS (Config3 bit 8) is set to 0. The fixed off-time is programmable through the serial interface and the current limit is set by an external sense resistor and a programmable reference voltage derived from the voltage at the REF input. During normal running, the internal current control can be used in conjunction with any external PWM control on the PWM input by ensuring that the programmable off-time of the internal control circuit is longer than the maximum off-time of the external PWM signal.

During the start-up sequence, the PWM input is ignored, unless it is held low in the brake condition. If IDS is set to 0, the current limit circuit provides full control over the hold torque and acceleration torque.

Current sense amplifier

A differential sense amplifier with a gain of 10 is provided to allow the use of low-value sense resistors or a current shunt as the current sensing element.

The output of the sense amplifier is compared to an internally generated reference voltage, V_{RI} , the value of which is programmed through the serial interface as a ratio of the voltage, V_{REF} , at the reference input terminal, REF. When the REF terminal is connected to VDD, V_{REF} is then limited to the reference clamp voltage, V_{REFC} .

V_{RI} can have a value between $6.25\%V_{REF}$ and $100\%V_{REF}$ defined as:

$$V_{RI} = [(n + 1) \times 6.25\%] \times V_{REF} \quad (2)$$

where n is a positive integer defined by VR[3:0] (Config1 bits 9:6).

For example, when VR[3:0] contains 1100 (12 in decimal), then $V_{RI} = 81.25\%V_{REF}$.

V_{RI} is generated by a digital-to-analog converter (DAC) with V_{REF} as the reference input to the DAC. V_{RI} will therefore scale directly with V_{REF} .

With the PWM input high, or during start-up when PWM is ignored, when the outputs of the MOSFETs are turned on, current increases in the motor winding until it reaches a value given by approximately:

$$I_{TRIP} \approx \frac{V_{RI}}{A_V \times R_{SENSE}} \quad (3)$$

where

V_{RI} is defined as above,

A_V is the gain of the sense amplifier, typically 10, and

R_{SENSE} is the value of the sense resistor.

At the trip point, the sense comparator switches off any active high-side MOSFETs and switches on the complementary low-side MOSFETs. This makes the bridge switch from a drive configuration, where the current is forced to increase, into a recirculation configuration, where the motor inductance causes the current to recirculate for a fixed duration defined as the off-time. During this off-time the current will decay at a rate defined by the motor inductance and the impedance of the MOSFET bridge. This is classic slow decay PWM current control.

Fixed off-time

The duration of the fixed off-time is set by the contents of PT[4:0] (Config2 bits 4:0). These five bits contain a positive integer that determines the off-time derived by division from the system clock.

The off-time is defined as:

$$t_{OFF} = 10 \mu s + (n \times 1.6 \mu s) \quad (4)$$

where n is a positive integer defined by PT[4:0].

For example, when PT[4:0] contains 11010 (26 in decimal), then $t_{OFF} = 51.6 \mu s$ typically.

The accuracy of t_{OFF} is determined by the accuracy of the system clock, t_{OSC} , as defined in the Electrical Characteristics table. A value of 00000 in PT[4:0] sets the minimum off-time of 10 μs .

Blank time

When the bridge is switched into the drive configuration, a current spike occurs due to the reverse-recovery currents of the clamp diodes and switching transients related to distributed capacitance in the load. To prevent this current spike from being detected as a current limit trip, the current-control comparator output is blanked for a short period of time when the source driver is turned on. The length of the blanking time is set by the contents of BT[3:0] (Config0 bits 9:6). These four bits contain a positive integer that determines the blank time derived by division from the system clock.

The blank time is defined as:

$$t_{\text{BL}} = n \times 400 \text{ ns} \quad (5)$$

where n is a positive integer defined by BT[3:0].

For example, when BT[3:0] contains 1011 (11 in decimal), then $t_{\text{BL}} = 4.4 \mu\text{s}$ typically.

The accuracy of t_{BL} is determined by the accuracy of the system clock, t_{OSC} , as defined in the Electrical Characteristics table.

The blank time is also used with the MOSFET drain-source monitors, which are used to determine MOSFET short faults. The blank time is used in these circuits, as shown in figure 4, to mask the effect of any voltage or current transients caused by any PWM switching action.

The user must ensure that blank time is long enough to mask any current transient seen by the internal sense amplifier and mask any voltage transients seen by the drain-source monitors.

Diagnostics

Several diagnostic features are integrated into the A4960 to provide indication of fault conditions. In addition to system-wide faults such as undervoltage and overtemperature, the A4960 integrates individual drain-source monitors for each external MOSFET, to provide short circuit detection.

The fault status is available from two sources, the DIAG output terminal and the serial interface.

DIAG pin

The DIAG terminal is a diagnostic output that can be programmed through the serial interface DG[1:0](Run bits 5:4) to provide any one of four alternative dedicated diagnostic signals:

- the general fault output flag
- the Sensorless Operation Indicator
- the programmed V_{DS} threshold voltage
- a clock signal derived from the internal chip clock

After a power-on reset the DIAG output defaults to the fault output flag. The general logic-level fault output flag outputs a low on the DIAG pin to indicate a fault is present. This fault output flag remains low while an unlatched fault is present or if one of the latched faults has been detected and the outputs are disabled. (Note there also is a common Fault flag, described in the Serial fault output section.)

The Sensorless Operation Indicator is a logic level signal that is set high when the A4960 has achieved sensorless commutation. The Sensorless Operation Indicator is set low before sensorless operation is achieved at start-up, or if sensorless operation is lost while the motor should be operating. This indicator is held high even when the motor is stopped, by setting RUN (Run bit 0) to 0 or BRK (Run bit 2) to 1.

The VDS threshold output provides access to the internal threshold voltage to allow more precise calibration of the MOSFET fault monitor threshold if required.

The clock output provides a logic-level square wave output to allow more precise calibration of the timing settings if required.

Serial interface fault output

The serial interface allows detailed diagnostic information to be read from the Diagnostic register at any time.

The first bit (bit 15) of the Diagnostic register contains the common Fault flag, FF, which is set high when any of the fault bits in the Diagnostic register have been set. This allows fault conditions to be detected using the serial interface by simply taking STRN low. As soon as STRN goes low the first bit in the Diagnostic register can be read to determine if a fault has been detected at any time since the last Diagnostic register reset. In all cases the fault bits in the Diagnostic register are latched and only cleared after a Diagnostic register reset (see Diagnostic Register section on serial access).

Note that FF does not provide the same function as the general fault output flag output on the DIAG pin (described above). The fault output on the DIAG pin provides an indication that certain types of faults are present and in some cases that the outputs have been disabled. FF provides an indication that certain types of faults have occurred since the last Diagnostic register reset and the respective fault bit has been set.

Fault response action

For certain fault conditions, the response of the A4960 is determined by the state of the Enable Stop on Fault bit, ESF (Run bit 6), as shown in table 2. When a short fault or overtemperature condition is detected, if ESF is set to 1 the A4960 disables all the gate drive outputs and coasts the motor. For short faults, this disabled state will be latched until RESETN goes low, a serial interface read is completed, or a power-on reset occurs. For undervoltage fault conditions, the outputs will always be disabled, regardless of the ESF bit setting.

When ESF is set to 0, although the general fault output flag (DIAG pin) is still activated (low), the A4960 will not disrupt normal operation under most conditions, and will therefore not protect the motor or the drive circuit from damage. It is imperative that the application master control circuit or other external circuit takes any necessary action when a fault occurs, to prevent damage to components.

Fault Mask register

Certain individual diagnostics can be disabled by setting the corresponding bit in the Mask register. If a bit is set to 1 in the Mask

register, then the corresponding diagnostic will be completely disabled. No fault states for the disabled diagnostic will be generated and neither the general fault output flag (DIAG pin) nor bits in the Diagnostic register will be set.

The VDD Undervoltage and VREG Undervoltage faults cannot be masked. V_{DD} undervoltage detection cannot be disabled because the diagnostics and the output control depend on VDD to operate correctly. V_{REG} undervoltage detection cannot be disabled because it is safe to turn on the gate drive outputs only when V_{REG} is at a sufficiently high voltage.

Note: Care must be taken when diagnostics are disabled to avoid potentially damaging conditions.

Chip-level diagnostics

Parameters critical for safe operation of the A4960 and the external MOSFETs are monitored. These include: maximum chip temperature, minimum logic supply voltage, and the various minimum voltages required to drive the external MOSFETs (V_{REG} and each of the bootstrap voltages). Note that the main supply voltage, V_{BB} , is not monitored for minimum voltage. This is because the critical minimum voltages are generated by the charge pumps internal to the A4960. When a fault is present, the general fault output flag (DIAG pin) will be active (low).

Chip Fault States: Temperature Thresholds

Two temperature threshold actions are provided: a high temperature warning and an overtemperature shutdown.

- If the chip temperature rises above the Temperature Warning Threshold, T_{JW} , the general fault output flag (DIAG pin) goes low and the High Temperature Warning bit, TW (Diagnostic bit 11) and the common Fault flag bit, FF (bit 15), are set to 1. No other action is taken by the A4960. When the temperature drops below T_{JW} by more than the hysteresis value, T_{JWHys} , the general fault output flag (DIAG pin) goes high, but TW and FF remain set in the Diagnostic register until a register reset.
- If the chip temperature rises above the Overtemperature Threshold, T_{JF} , the general fault output flag (DIAG pin) goes low and the overtemperature bit, TS (Diagnostic bit 10) and the common Fault flag bit, FF (bit 15), are set to 1. When ESF (Run bit 6) is set to 1, if an overtemperature is detected, all gate drive outputs will be disabled automatically. If an overtemperature condition occurs when ESF is set to 0, then no circuitry will be disabled and action must be taken by the user to limit the power dissipa-

Table 2: Fault Response Actions

Fault Description	Disable Outputs		Fault Latched
	ESF = 0	ESF = 1	
No fault	No	No	n.a.
VDD Undervoltage	Yes*	Yes*	No
VREG Undervoltage	Yes*	Yes*	No
Bootstrap Undervoltage	Yes*	Yes*	Yes
Temperature Warning	No	No	No
Overtemperature	No	Yes*	No
Short to Ground	No	Yes*	Only when ESF = 1
Short to Supply	No	Yes*	
Shorted Load	No	Yes*	

* All gate drives low, all MOSFETs off

tion in some way, so as to prevent overtemperature damage to the chip and unpredictable device operation. When the temperature drops below T_{JF} by more than the hysteresis value, T_{JFHys} , the general fault output flag (DIAG pin) goes high, but the overtemperature bit, TS, and FF remain set in the Diagnostic register until cleared.

Chip Fault State : VREG Undervoltage

The internal charge-pump regulator supplies the low-side gate driver and the bootstrap charge current. Before enabling any of the outputs, it is critical to ensure that the regulated voltage, V_{REG} , at the VREG terminal is sufficiently high.

If V_{REG} goes below the VREG Undervoltage Threshold, $V_{REGUVOFF}$, the general fault output flag (DIAG pin) goes low and the VREG undervoltage bit, VR (Diagnostic bit 13) and the common Fault flag bit, FF (bit 15), are set to 1. All gate drive outputs go low, the motor drive is disabled, and the motor coasts. When V_{REG} rises above $V_{REGUVON}$, the gate drive outputs are re-enabled and the general fault output flag (DIAG pin) goes high. The fault bit, VR, and FF remain set in the Diagnostic register until cleared.

The VREG undervoltage monitor circuit is active during power-up. The general fault output flag (DIAG pin) is low and all gate drives will be low until V_{REG} is greater than approximately 8 V. Note that this is sufficient to turn on standard-threshold, external power MOSFETs at a battery voltage as low as 5.5 V, but the on-resistance of the MOSFET may be higher than its specified maximum.

Chip Fault State: VDD Undervoltage

The logic supply voltage, V_{DD} , at the VDD terminal is monitored to ensure correct logical operation. If V_{DD} drops below the VDD Undervoltage Threshold, V_{DDUV} , then the logical function of the A4960 cannot be guaranteed and the outputs will be immediately disabled. The A4960 will enter a power-down state and all internal activity, other than the V_{DD} voltage monitor, will be suspended.

When V_{DD} rises above the rising undervoltage threshold, $V_{DDUV} + V_{DDUVHys}$, the A4960 will perform a power-on reset. All serial control registers will be reset to their power-on state, all fault conditions and fault-specific bits in the Diagnostic register will be reset, and the general fault output flag (DIAG pin) will go high. The FF bit and the POR bit (Diagnostic bits 15 and 14) will be set to 1 to indicate that a power-on reset has taken place.

The same power-on reset sequence occurs for initial power-on, and also for a V_{DD} “brown-out,” where V_{DD} drops below V_{DDUV} only momentarily.

Bootstrap Undervoltage Fault State

In addition to a monitor on V_{REG} , the A4960 also monitors the individual bootstrap capacitor charge voltages to ensure sufficient high-side drive. Before a high-side drive can be turned on, the bootstrap capacitor voltage must be higher than the turn-on voltage limit, $V_{BOOTUV} + V_{BOOTUVHys}$. If this is not the case, then the A4960 will attempt to charge the bootstrap capacitor by activating the complementary low-side drive. Under normal circumstances this will charge the capacitor above the turn-on voltage in a few microseconds and the high-side drive will then be enabled.

The bootstrap voltage monitor remains active while the high-side drive is active, and if the voltage drops below the turn-off voltage, V_{BOOTUV} , a charge cycle is also initiated. In either case, if there is a fault that prevents the bootstrap capacitor charging, then the charge cycle will time out, the general fault output flag (DIAG pin) will go low, and the outputs will be disabled. The appropriate bit (VA, VB, or VC, according to the phase) in the Diagnostic register will be set to allow the faulty bootstrap capacitor to be determined by reading the serial data word from the Diagnostic register.

The bootstrap undervoltage fault state will be latched until RESETN is set low, a serial interface read is completed, or a power-on reset occurs due to a V_{DD} undervoltage on the logic supply.

MOSFET fault detection

Faults on external MOSFETs are determined by measuring the drain-source voltage of the MOSFET and comparing it to the Drain-Source Threshold Voltage, V_{DSTH} , defined by VT[5:0] (Config1 bits 5:0). These bits provide the input to a 6-bit DAC with a least significant bit value of typically 25 mV. The output of the DAC produces V_{DSTH} , defined as approximately:

$$V_{DSTH} \approx n \times 25 \text{ mV} \quad (6)$$

where n is a positive integer defined by VT[5:0].

For example, when VT[5:0] contains 101000 (40 in decimal), then $V_{DSTH} = 1 \text{ V}$ typically. The accuracy of V_{DSTH} is defined in the Electrical Characteristics table.

The low-side drain-source voltage for any MOSFET is measured between the LSS terminal and the appropriate Sx terminal. Using the LSS terminal rather than the ground connection avoids adding any low-side current sense voltage to the real low-side drain-source voltage. The high-side drain-source voltage for any MOSFET is measured between the VBRG terminal and the appropriate Sx terminal. Using the VBRG terminal rather than the

bridge supply avoids adding any high-side current sense voltage to the real high-side drain-source voltage.

The VBRG terminal is a low-current sense input to the top of the external MOSFET bridge. It should be connected directly to the common connection point for the drains of the power bridge MOSFETs at the positive supply connection point. The input current to the VBRG terminal is proportional to the drain-source threshold voltage, V_{DSTH} , and is approximately:

$$I_{VBRG} = 72 \times V_{VBRG} + 52 \quad (7)$$

where I_{VBRG} is the current into the VBRG terminal in μA and V_{DSTH} is the Drain-Source Threshold Voltage, described above.

Note that the VBRG terminal can withstand a negative voltage as great as -5 V . This allows the terminal to remain connected directly to the top of the power bridge during negative transients where the body diodes of the power MOSFETs are used to clamp the negative transient. The same applies to the more extreme case where the MOSFET body diodes are used to clamp a reverse battery connection.

MOSFET fault blank time

To avoid false MOSFET fault detection during switching transients the V_{DS} -to- V_{DSTH} comparison is delayed, following a MOSFET turn-on, by the internal blank timer. This is the same blank time as used for current sensing phase voltage monitoring. The length of the blanking time is set by the contents of BT[3:0] (Config0 bits 9:6). These four bits contain a positive integer that determines the blank time derived by division from the system clock.

The blank time is defined as in equation 5:

$$t_{BL} = n \times 400 \text{ ns}$$

where n is a positive integer defined by BT[3:0].

For example, when BT[3:0] contains 1001 (9 in decimal), then $t_{BL} = 3.6 \mu\text{s}$ typically.

The accuracy of t_{BL} is determined by the accuracy of the system clock, t_{OSC} , as defined in the Electrical Characteristics table.

Short fault operation

Power MOSFETs take a finite time to reach the rated on-resistance, so the measured drain-source voltages may show a fault as the phase switches. To overcome this and avoid false short fault detection, the voltages are not sampled until a blank time elapses after the external MOSFET is turned on. If the drain-source voltage remains above the threshold after the blank time, then a short

fault will be detected. If ESF (Run bit 6) is set to 1 this fault will be latched and the MOSFET disabled until there is an A4960 Diagnostic register reset.

If a short circuit fault occurs when ESF is set to 0, then the external MOSFETs are not disabled by the A4960. To limit any damage to the external MOSFETs or the motor, the A4960 should either be fully disabled by the RESETN input or all MOSFETs switched off by setting RUN (bit 0 in the Run register) to 0, through a serial interface write. Alternatively, setting the ESF bit to 1 will allow the A4960 to disable the MOSFETs as soon as a fault is detected.

MOSFET Fault State: Short to Supply

A short from any of the motor phase connections to the battery or VBB connection is detected by monitoring the voltage across the low-side MOSFETs in each phase using the respective S_x terminal and the LSS terminal. This drain-source voltage is then compared to the Drain-Source Threshold Voltage, V_{DSTH} , after a blank time. While the drain source voltage exceeds V_{DSTH} , the general fault output flag (DIAG pin) will be low and, when ESF is set to 1, it will be latched low and the outputs will be disabled.

MOSFET Fault State: Short to Ground

A short from any of the motor phase connections to ground is detected by monitoring the voltage across the high-side MOSFETs in each phase using the respective S_x terminal and the voltage at VBRG. This drain-source voltage is then compared to the Drain-Source Threshold Voltage, V_{DSTH} , after a blank time. While the drain source voltage exceeds V_{DSTH} the general fault output flag on the DIAG pin will be low and, when ESF is set to 1, it will be latched low and the outputs will be disabled.

Note: The distinction between short to ground and short to supply can only be made by examining the serial Diagnostic register. The general fault output flag (DIAG pin) simply indicates the presence of a probable short circuit.

MOSFET Fault State: Shorted Winding

The short to ground and short to supply detection circuits will also detect a short across a motor phase winding. In most cases a shorted winding will be indicated by a high-side and low-side fault latched at the same time in the Diagnostic register. In some cases the relative impedances may only permit one of the shorts to be detected. In any case when a short of any type is detected the general fault output flag (DIAG pin) will go low and, when ESF is set to 1, it will be latched low and the outputs will be disabled.

Serial Interface Description

A three wire synchronous serial interface, compatible with SPI, is used to control the features of the A4960. A fourth wire can be used to provide diagnostic feedback and read back of register contents.

The A4960 can be started only by using the serial interface to set the RUN bit (Run bit 0) to 1. Application specific settings are configured by setting the appropriate register bits through the serial interface.

The serial interface timing requirements are specified in the Electrical Characteristics table, and illustrated in figure 1. Data is received on the SDI terminal and clocked through a shift register on the rising edge of the clock signal input on the SCK terminal. STRN is normally held high, and is brought low only to initiate a serial transfer. No data is clocked through the shift register when STRN is high, allowing multiple slave units to use common SDI,

SCK, and SDO connections. Each slave then requires an independent STRN connection.

When 16 data bits have been clocked into the shift register, STRN must be taken high to latch the data into the selected register. When this occurs, the internal control circuits act on the new data and the Diagnostic register is reset.

If there are more than 16 rising edges on SCK, or if STRN goes high and there are fewer than 16 rising edges on SCK, the write will be cancelled without writing data to the registers. In addition the Diagnostic register will not be reset and the FF bit (Diagnostic bit 15) will be set to 1 to indicate a data transfer error.

Diagnostic information or the contents of the configuration and control registers is output on the SDO terminal, MSB first, while STRN is low. The output stream changes to the next bit on each falling edge of SCK. The first bit, which is always the FF bit, is output as soon as STRN goes low.

Table 3. Serial Registers Definition

	15	14	13	12	11	10	9	8	7	6	5	4	3	2	1	0
Config 0 (Blank,Dead)	0	0	0	WR	CB1	CB0	BT3	BT2	BT1	BT0	DT5	DT4	DT3	DT2	DT1	DT0
	0	0	0		0	0	1	0	0	0	0	0	1	0	1	0
Config 1 (V _{REF} ,V _{DSTH})	0	0	1	WR			VR3	VR2	VR1	VR0	VT5	VT4	VT3	VT2	VT1	VT0
	0	0	0		0	0	1	1	1	1	1	0	0	0	0	0
Config 2 (PWM)	0	1	0	WR								PT4	PT3	PT2	PT1	PT0
	0	0	0		0	0	0	0	0	0	0	0	1	0	0	0
Config 3 (Hold)	0	1	1	WR				IDS	HQ3	HQ2	HQ1	HQ0	HT3	HT2	HT1	HT0
	0	0	0		0	0	0	0	1	0	1	0	0	1	0	0
Config 4 (Start Com)	1	0	0	WR					EC3	EC2	EC1	EC0	SC3	SC2	SC1	SC0
	0	0	0		0	0	0	0	1	1	1	1	0	1	0	0
Config 5 (Ramp)	1	0	1	WR	PA3	PA2	PA1	PA0	RQ3	RQ2	RQ1	RQ0	RR3	RR2	RR1	RR0
	0	0	0		0	0	0	0	1	0	0	0	0	0	0	0
Mask	1	1	0	WR	TW	TS	LOS	VA	VB	VC	AH	AL	BH	BL	CH	CL
	0	0	0		0	0	0	0	0	0	0	0	0	0	0	0
Run	1	1	1	WR	BH1	BH0	BW2	BW1	BW0	ESF	DG1	DG0	RSC	BRK	DIR	RUN
	0	0	0		0	0	0	0	0	0	0	0	0	0	0	0
Diagnostic	FF	POR	VR		TW	TS	LOS	VA	VB	VC	AH	AL	BH	BL	CH	CL
	1	1	0	0	0	0	0	0	0	0	0	0	0	0	0	0

*Power-on reset value shown below each input register bit.

Each of the 8 configuration and control registers has a write bit, WR (bit 12), as the first bit after the register address (bits 15:13). This bit must be set to 1 to write the subsequent bits into the selected register. If WR is set to 0 then the remaining data bits (bits 11:0) are ignored.

The state of the WR bit also determines the data output on SDO. By setting the WR bit to 1, writing to any register will allow the Diagnostic register to be read at the SDO output. If WR is set to 0, then the output is the contents of the register addressed by the first three input bits. In all cases the first three bits output on SDO will always be the FF, POR, and VR bits from the Diagnostic register.

Configuration and control registers

The serial data word is 16 bits, input MSB first, with the first three bits defined as the register address. This provides eight writable registers:

- Six registers are used for configuration: one for blank time and dead time programming, one for current and voltage limits, one for PWM set-up parameters, and three for start-up parameters.
- The seventh register is the fault Mask register, which provides the ability to disable individual diagnostics.
- The eighth register is the Run register, containing motor control inputs.

Config0 Configuration register 0 contains basic timing settings:

- CB[1:0], 2 bits to select the commutation blank time, t_{CB}
- BT[3:0], a 4-bit integer to set the blank time, t_{BL} , in 400 ns increments
- DT[5:0], a 6-bit integer to set the dead time, t_{DEAD} , in 50 ns increments

Config1 Configuration Register 1 contains basic voltage settings:

- VR[3:0], a 4-bit integer to set the current limit reference voltage, V_{RI} , as a ratio of the voltage at the REF terminal, V_{REF}
- VT[5:0], a 6-bit integer to set the Drain-Source Threshold Voltage, V_{DSTH} , in 25 mV increments

Config2 Configuration Register 2 contains PWM settings:

- PT[4:0], a 5-bit integer to set the off-time for the PWM current control used to limit the motor current during start-up and normal running

Config3 Configuration Register 3 contains start-up hold settings:

- IDS, to select between current control and duty cycle control to set the initial holding torque.
- HQ[3:0], a 4-bit integer to set the holding torque for the initial start position. The holding torque is set by an internally generated PWM duty cycle or by internal PWM current control.
 - If IDS is set to zero then HQ[3:0] selects the hold current in increments of 6.25%.
 - If IDS is set to one then HQ[3:0] selects the duty cycle in increments of 6.25%.
- HT[3:0], a 4-bit integer to set the hold time of the initial start position in increments of 8 ms from 2 ms.

Config4 Configuration Register 4 contains start-up timing settings:

- EC[3:0], a 4-bit integer to set the end commutation time in increments of 200 μ s.
- SC[3:0], a 4-bit integer to set the start commutation time in increments of 8 ms.

Config5 Configuration Register 5 contains start-up ramp settings:

- PA[3:0], a 4-bit integer to set the phase advance in increments of 1.875° (electrical degrees)
- RQ[3:0], a 4-bit integer to set the torque during ramp-up. The ramp torque is set by an internally generated PWM duty cycle or by internal PWM current control.
 - If ISD is set to zero then RQ[3:0] selects the hold current in increments of 6.25%.
 - If ISD is set to one then RQ[3:0] selects the duty cycle in increments of 6.25%.
- RR[3:0], a 4-bit integer to set the acceleration rate during the forced commutation ramp up. Sets the reduction in commutation time, in 200 μ s steps, at each commutation change.

Mask This register contains a fault masking bit for each fault bit in the Diagnostic register. If a bit is set to one in the Mask register then the corresponding diagnostic will be completely disabled. No fault states for the disabled diagnostic will be generated and no fault flags or diagnostic bits will be set.

Run This register contains various bits to set running conditions:

- BH[1:0], 2 bits to select the BEMF hysteresis.
- BW[2:0], 3 bits to select the BEMF window.
- ESF, the Enable Stop on Fault bit; defines the action taken when a short is detected. See Diagnostics section for details of fault actions.
- DG[1:0], 2 bits to select the output routed to the DIAG terminal. The default output is the general fault output flag, which is a low true (active low) signal that is active anytime a fault is present or a fault state has been latched. The second option sets the DIAG output high whenever the A4960 is running with sensorless commutation. The other two outputs provide an external controller with the facility to read back the drain-source threshold voltage, or to measure the system clock frequency for calibration.
- RSC, the Restart control bit.
 - When set to 1 allows restart after loss of BEMF synchronization if RUN is 1 and BRK is 0.
 - When set to 0 the motor will coast to a stop when bemf synchronization is lost.
- BRK, brake control.
- DIR, direction control.
- RUN, enables the A4960 to start and run the motor.

Diagnostic register

There is one diagnostic register in addition to the eight writable registers. Each time a register is written, the Diagnostic register can be read, MSB first, on the serial output terminal, SDO (see serial timing diagram, figure 1). The Diagnostic register contains fault flags for each fault condition and a general fault flag. Whenever a fault occurs, the corresponding flag bit in the Diagnostic register will be set and latched.

The fault flags in the Diagnostic register are reset only on the completion of a serial interface access, or when the RESETN input is low for the Reset Pulse Width, t_{RES} . Resetting the Diagnostic register only affects latched faults that are no longer present. For any static faults that are still present, for example overtemperature, the fault flag will remain set after the register reset.

At power-up or after a power-on reset, the FF bit and the POR bit are set and all other bits are reset. This indicates to the external controller that a power-on reset has taken place and all registers have been reset. Note that a power-on reset only occurs when the VDD supply rises above its undervoltage threshold. Power-on reset is not affected by the state of the VBB supply or VREG.

The first bit in the register is the diagnostic register flag, FF. This is high if any bits in the diagnostic register are set or if a serial write error has occurred. When STRN goes low to start a serial write SDO comes out of its high impedance state and outputs the serial register fault flag. This allows the main controller to poll the A4960 through the serial interface to determine if a fault has been detected. If no faults have been detected then the serial transfer may be terminated without generating a serial read fault by ensuring that SCK remains high while STRN is low. When STRN goes high the transfer will be terminated and SDO will go into its high impedance state.

Serial Register Reference

	15	14	13	12	11	10	9	8	7	6	5	4	3	2	1	0
Config 0	0	0	0	WR	CB1	CB0	BT3	BT2	BT1	BT0	DT5	DT4	DT3	DT2	DT1	DT0
					0	0	1	0	0	0	0	1	0	1	0	0
Config 1	0	0	1	WR			VR3	VR2	VR1	VR0	VT5	VT4	VT3	VT2	VT1	VT0
							1	1	1	1	1	0	0	0	0	0

*Power on reset value shown below each input register bit.

Configuration Register 0

CB[1:0] Commutation blank time

CB1	CB0	Blank Time	Default
0	0	50µs	D
0	1	100µs	
1	0	400µs	
1	1	1ms	

The accuracy of t_{CB} is determined by the system clock frequency as defined in the electrical characteristics table.

BT[3:0] Blank time

$$t_{BL} = n \times 400 \text{ ns}$$

where n is a positive integer defined by BT[3:0]

e.g. for the power-on-reset condition

BT[3:0] = [1 0 0 0] then $t_{BL}=3.2\mu\text{s}$

The range of t_{BL} is 0 to 6µs.

The accuracy of t_{BL} is determined by the system clock frequency as defined in the electrical characteristics table.

DT[5:0] Dead time

$$t_{DEAD} = n \times 50 \text{ ns}$$

where n is a positive integer defined by DT[5:0]

e.g. for the power-on-reset condition

DT[5:0] = [0 1 0 1 0 0] then $t_{DEAD}=1\mu\text{s}$

The range of is 100ns to 3.15µs. Selecting a value of 0, 1 or 2 will set the dead time to 100ns.

The accuracy of t_{DEAD} is determined by the system clock frequency as defined in the electrical characteristics table.

Configuration Register 1

VR[3:0] Current sense reference ratio for normal running conditions.

Typically:

$$V_{RI} = (n + 1) \times 6.25\% V_{REF}$$

where n is a positive integer defined by VR[3:0]

e.g. for the power-on-reset condition

VR[3:0] = [1 1 1 1] then $V_{RI}=V_{REF}$

If the REF terminal is connected to VDD then V_{REF} is clamped to V_{REFC} .

The range of V_{RI} is 6.25% V_{REF} to 100% V_{REF} .

VT[5:0] VDS Threshold.

Typically:

$$V_{DSTH} = n \times 25 \text{ mV}$$

where n is a positive integer defined by VT[5:0]

e.g. for the power-on-reset condition

VT[5:0] = [1 0 0 0 0 0] then $V_{DSTH}=800\text{mV}$

The range of V_{DSTH} is 0 to 1.575V.

Serial Register Reference

	15	14	13	12	11	10	9	8	7	6	5	4	3	2	1	0
Config 2 (PWM)	0	1	0	WR								PT4	PT3	PT2	PT1	PT0
												1	0	0	0	0
Config 3 (Hold)	0	1	1	WR				IDS	HQ3	HQ2	HQ1	HQ0	HT3	HT3	HT1	HT0
								0	0	1	0	1	0	1	0	0

*Power on reset value shown below each input register bit.

Configuration Register 2

PT[4:0] Fixed off time

$$t_{OFF} = 10 \mu s + (n \times 1.6 \mu s)$$

where *n* is a positive integer defined by PT[4:0]

e.g. for the power-on-reset condition

PT[4:0] = [1 0 0 0 0] then $t_{OFF}=35.6 \mu s$

The range of t_{OFF} is 10µs to 59.6µs.

The accuracy of t_{OFF} is determined by the system clock frequency as defined in the electrical characteristics table.

Configuration Register 3

IDS Start-up Torque control method

IDS	Start-up Torque control	Default
0	Current limited	D
1	Duty cycle limited	

HQ[3:0] Current sense reference ratio or duty cycle ratio for hold torque during initial start sequence.
 If IDS is 0 then HQ[3:0] sets the hold current.
 If IDS is 1 then HQ[3:0] sets the hold duty cycle.

Typically:

$$V_{RH} = (n + 1) \times 6.25\% V_{REF} \dots \dots \text{when IDS}=0$$

$$D_H = (n + 1) \times 6.25\% \dots \dots \dots \text{when IDS}=1$$

where *n* is a positive integer defined by HQ[3:0]

e.g. for the power-on-reset condition

HQ[3:0] = [0 1 0 1] then

$$V_{RH}=37.5\%V_{REF} \dots \dots \dots \text{when IDS}=0$$

$$D_H=37.5\% \dots \dots \dots \text{when IDS}=1$$

The range of V_{RH} is 6.25% V_{REF} to 100% V_{REF} .

The range of D_H is 6.25% to 100%.

The accuracy of V_{RH} and D_H is defined in the electrical characteristics table.

HT[3:0] Hold Time.

$$t_{HOLD} = 2ms + (n \times 8ms)$$

where *n* is a positive integer defined by HT[3:0]

e.g. for the power-on-reset condition

HT[3:0] = [0 1 0 0] then $t_{HOLD}=34ms$

The range of t_{HOLD} is 2ms to 122ms.

The accuracy of t_{HOLD} is determined by the system clock frequency as defined in the electrical characteristics table.

Serial Register Reference

	15	14	13	12	11	10	9	8	7	6	5	4	3	2	1	0
Config 4 (Start Com)	1	0	0	WR					EC3	EC2	EC1	EC0	SC3	SC2	SC1	SC0
									1	1	1	1	0	1	0	0
Config 5 (Ramp)	1	0	1	WR	PA3	PA2	PA1	PA0	RQ3	RQ2	RQ1	RQ0	RR3	RR2	RR1	RR0
					0	0	0	0	1	0	0	0	0	0	0	0

*Power on reset value shown below each input register bit.

Configuration Register 4

EC[3:0] End Commutation time

$$t_{COME} = (n + 1) \times 0.2ms$$

where *n* is a positive integer defined by EC[3:0]

e.g. for the power-on-reset condition

EC[3:0] = [1 1 1 1] then *t*_{COME}=3.2ms

The range of *t*_{COME} is 0.2ms to 3.2ms.

The accuracy of *t*_{COME} is determined by the system clock frequency as defined in the electrical characteristics table.

SC[3:0] Start commutation time

$$t_{COMS} = (n + 1) \times 8ms$$

where *n* is a positive integer defined by SC[3:0]

e.g. for the power-on-reset condition

SC[3:0] = [0 1 0 0] then *t*_{COMS}=40ms

The range of *t*_{COMS} is 8ms to 128ms.

The accuracy of *t*_{COMS} is determined by the system clock frequency as defined in the electrical characteristics table.

Configuration Register 5

PA[3:0] Phase Advance.

Typically:

$$\theta_{ADV} = n \times 1.875^\circ (\text{electrical})$$

where *n* is a positive integer defined by PA[3:0]

e.g. for the following condition

PA[3:0] = [1 0 0 0] then $\theta_{ADV}=15^\circ$

The range of θ_{ADV} is 0 to 28.125° (electrical)

The accuracy of θ_{ADV} is defined in the electrical characteristics table.

RQ[3:0] Current sense reference ratio or duty cycle ratio for torque during forced commutation ramp-up. If IDS is 0 then RQ[3:0] sets the ramp current. If IDS is 1 then RQ[3:0] sets the ramp duty cycle.

Typically:

$$V_{RR} = (n + 1) \times 6.25\% V_{REF} \dots \dots \dots \text{when IDS}=0$$

$$D_R = (n + 1) \times 6.25\% \dots \dots \dots \text{when IDS}=1$$

where *n* is a positive integer defined by RQ[3:0]

e.g. for the power-on-reset condition

RQ[3:0] = [1 0 0 0] then

$$V_{RH}=56.25\%V_{REF} \dots \dots \dots \text{when IDS}=0$$

$$D_H=56.25\% \dots \dots \dots \text{when IDS}=1$$

The range of *V*_{RR} is 6.25% *V*_{REF} to 100%*V*_{REF}.

The range of *D*_R is 6.25% to 100%.

The accuracy of *V*_{RR} and *D*_R is defined in the electrical characteristics table.

RR[3:0] Ramp rate.

Decrease in commutation time at each commutation change.

Typically at each commutation change:

$$t_{COM(next)} = t_{COM} - (n + 1) \times 0.2ms$$

where *t*_{COM(next)} is the next commutation time in ms,

*t*_{COM} is the present commutation time in ms,

and *n* is a positive integer defined by RR[3:0]

e.g. for the condition RR[3:0] = [0 1 1 1]

the commutation time will be reduced by 1.6ms at each commutation change.

The range of RR is 0 to 15.

The range of the commutation change is 0.2ms to 3.2ms.

The accuracy of RR is determined by the system clock frequency as defined in the electrical characteristics table.

Serial Register Reference

	15	14	13	12	11	10	9	8	7	6	5	4	3	2	1	0
Run	1	1	1	WR	BH1	BH0	BW2	BW1	BW0	ESF	DG1	DG0	RSC	BRK	DIR	RUN
					0	0	1	0	0	0	0	0	0	0	0	0

*Power on reset value shown below each input register bit.

Run Register

BH[1:0] BEMF Hysteresis.

BH1	BH0	Hysteresis	Default
0	0	Auto High Start/Low Run	D
0	1	None	
1	0	High	
1	1	Low	

BW[2:0] BEMF Window.

BW2	BW1	BW0	Window	Default
0	0	0	0.4 μ s	
0	0	1	0.8 μ s	
0	1	0	1.6 μ s	
0	1	1	3.2 μ s	
1	0	0	6.4 μ s	D
1	0	1	12.8 μ s	
1	1	0	25.6 μ s	
1	1	1	51.2 μ s	

ESF Enable Stop on Fail

ESF	Recirculation	Default
1	Stop on fail. Report fault.	
0	No stop on fail, Report fault.	D

DG[1:0] Selects signal routed to DIAG output.

DG1	DG0	Signal on DIAG pin	Default
0	0	Fault- low true	D
0	1	LOS - low true	
1	0	VDSTH	
1	1	Clock	

RSC Restart control

RSC	Restart	Default
0	No restart	D
1	Allow restart after loss of sync	

BRK Brake

BRK	Recirculation	Default
0	Brake off - normal operation	D
1	Brake on - slow decay recirculation	

DIR Direction of Rotation

DIR	Direction	Default
0	Forward (Table 1 states 1 to 6)	D
1	Reverse (Table 1 states 6 to 1)	

RUN Run enable

RUN	Recirculation	Default
0	Disable outputs, coast motor	D
1	Start and run motor	

Serial Register Reference

	15	14	13	12	11	10	9	8	7	6	5	4	3	2	1	0
Mask	1	1	0	WR	TW	TS	LOS	VA	VB	VC	AH	AL	BH	BL	CH	CL
					0	0	0	0	0	0	0	0	0	0	0	0
Diagnostic	FF	POR	VR		TW	TS	LOS	VA	VB	VC	AH	AL	BH	BL	CH	CL
	1	1	0	0	0	0	0	0	0	0	0	0	0	0	0	0

*Power on reset value shown below each input register bit.

Mask Register

- TW Temperature warning
- TS Thermal shutdown
- LOS Loss of bmf synchronization
- VA Bootcap A fault
- VB Bootcap B fault
- VC Bootcap B fault
- AH Phase A high-side V_{DS}
- AL Phase A low-side V_{DS}
- BH Phase B high-side V_{DS}
- BL Phase B low-side V_{DS}
- CH Phase C high-side V_{DS}
- CL Phase C low-side V_{DS}

xx	Fault mask	Default
0	Fault detection permitted	D
1	Fault detection disabled	

Diagnostic Register

- FF General Fault flag
- POR Power-on-reset
- VR Undervoltage
- TW High temperature warning
- TS Over temperature shutdown
- LOS bmf synchronization lost
- VA Fault on bootcap A
- VB Fault on bootcap B
- VC Fault on bootcap C
- AH V_{DS} fault detected on Phase A high-side
- AL V_{DS} fault detected on Phase A low-side
- BH V_{DS} fault detected on Phase B high-side
- BL V_{DS} fault detected on Phase B low-side
- CH V_{DS} fault detected on Phase C high-side
- CL V_{DS} fault detected on Phase C low-side

xx	Fault
0	No fault detected
1	Fault detected

Applications Information

Control Timing Diagrams

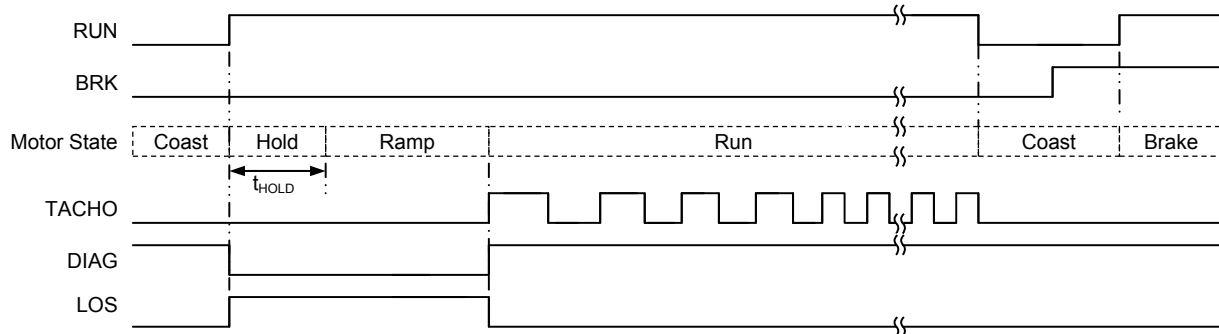

Figure 9. Control example: Start from coast, coast, then brake to stop

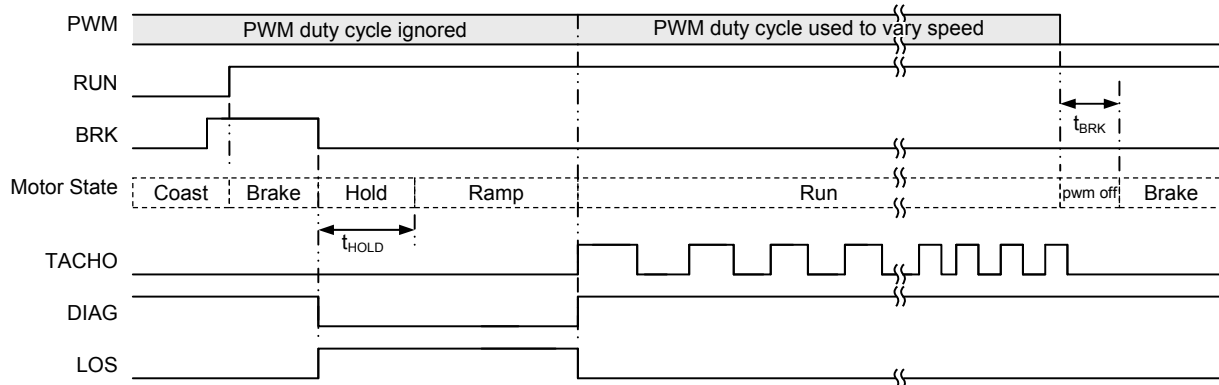

Figure 10. Control example: Start from brake, PWM brake to stop

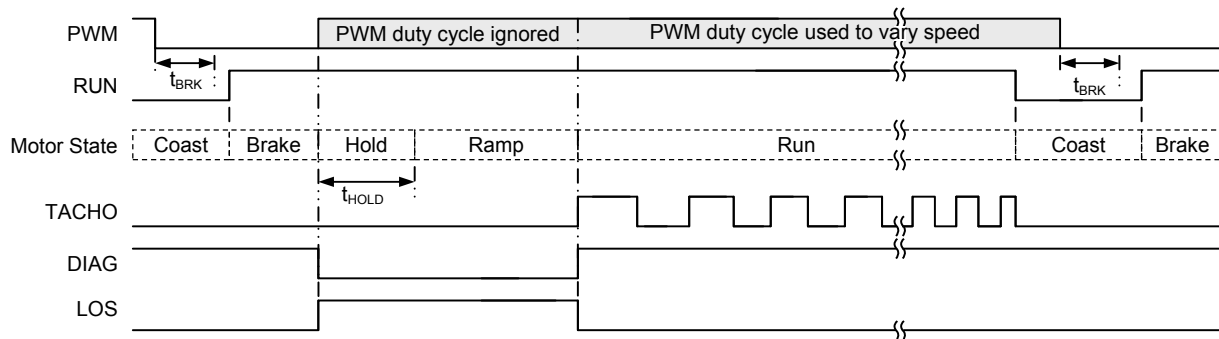
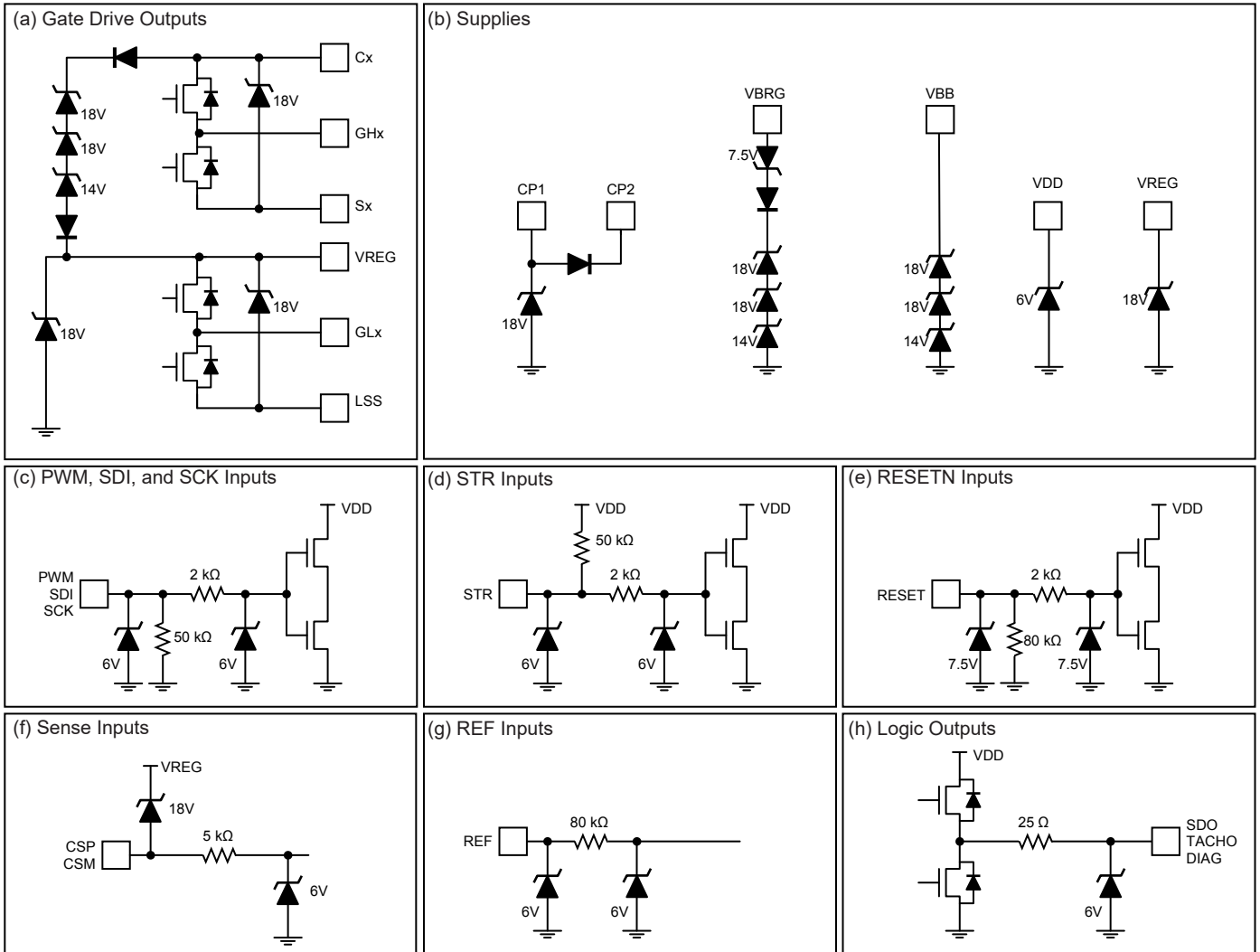

Figure 11. Control example: Start from PWM, coast, then PWM brake to stop

Input/Output Structures



Package JP, 32-Pin LQFP With Exposed Thermal Pad

For Reference Only – Not for Tooling Use

(Reference Allegro DWG-0000386, Rev. 5 or JEDEC MS-026 BBAHD)

NOT TO SCALE

Dimensions in millimeters

Dimensions exclusive of mold flash, gate burrs, and dambar protrusions
Exact case and lead configuration at supplier discretion within limits shown

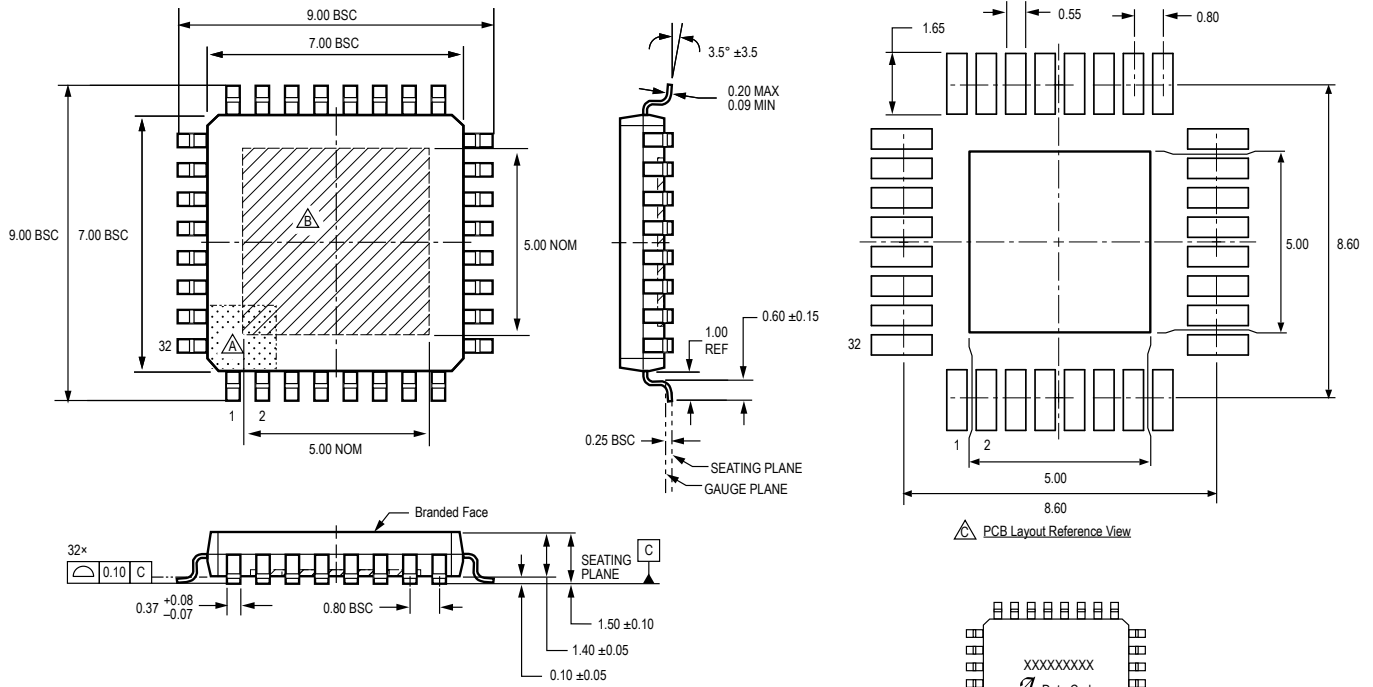

- △ Terminal #1 mark area
- △ Exposed thermal pad (bottom surface); exact dimensions may vary with device
- △ Reference land pattern layout (reference IPC7351 QFP80P900X900X160-32BM); adjust as necessary to meet application process requirements and PCB layout tolerances; when mounting on a multilayer PCB, thermal vias at the exposed thermal pad land can improve thermal dissipation (reference EIA/JEDEC Standard JESD51-5)
- △ Branding scale and appearance at supplier discretion

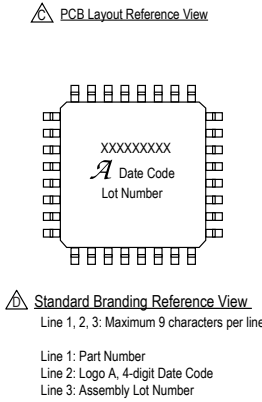

Revision Table

Revision Number	Revision Date	Description
–	October 6, 2011	Initial Release
1	September 9, 2015	Corrected Figure 10 (page 31) DIAG and LOS signals
2	April 24, 2017	Corrected pinout diagram typo (page 4)
3	April 25, 2019	Minor editorial updates
4	April 27, 2022	Updated package drawing (page 33)

Copyright 2022, Allegro MicroSystems.

Allegro MicroSystems reserves the right to make, from time to time, such departures from the detail specifications as may be required to permit improvements in the performance, reliability, or manufacturability of its products. Before placing an order, the user is cautioned to verify that the information being relied upon is current.

Allegro's products are not to be used in any devices or systems, including but not limited to life support devices or systems, in which a failure of Allegro's product can reasonably be expected to cause bodily harm.

The information included herein is believed to be accurate and reliable. However, Allegro MicroSystems assumes no responsibility for its use; nor for any infringement of patents or other rights of third parties which may result from its use.



Copies of this document are considered uncontrolled documents.

For the latest version of this document, visit our website:

www.allegromicro.com

Looking for pricing, stock, or lifecycle information?

Click below to explore more details on WIN SOURCE:

-  [View A4960SJPTR-T on WIN SOURCE](#)
-  [Allegro MicroSystems, LLC Information](#)

Optimize Your Supply Chain with WIN SOURCE Solutions

-  Global Sourcing Solution
-  Obsolete Management
-  Cost Control Management
-  Shortage Management
-  Alternative Solution
-  Excess Inventory Management