



**THE DATASHEET OF
APS12170LUAATN**



Two-Wire Continuous Time Hall-Effect Latch

FEATURES AND BENEFITS

- Symmetrical latch switch points
- Automotive-grade ruggedness and fault tolerance
 - Extended AEC-Q100 Grade 0 qualification
 - Reverse-battery and 40 V load dump protection
 - Operation from -40°C to 175°C junction temperature
 - High EMC immunity, ± 12 kV HBM ESD
 - Undervoltage lockout
 - Overvoltage clamping protection
 - Resistant to physical stress
- Operation from unregulated supplies, 3.8 to 16 V
- Continuous-time operation
 - Fast power-on time
 - Low EMI emissions
 - Low latency
 - Regulator stability without a bypass capacitor
- Current mode output—voltage controlled
- Solid-state reliability
- Industry-standard packages and pinouts

PACKAGES:

Not to scale



DESCRIPTION

The APS12170 is a two-wire, planar Hall-effect sensor integrated circuit (IC) operating under a continuous-time sensing architecture. The devices are extremely fast responding with lower levels of emissions (EMI) than a design using chopper stabilization.

This Hall-effect latch IC features extended AEC-Q100 qualification and is ideal for high-temperature operation up to 175°C junction temperatures. In addition, the APS12170 includes a number of features designed specifically to maximize system robustness, such as reverse-battery protection, overvoltage, and EMC protection.

A south pole and a north pole of sufficient strength are both necessary to actuate the device. The devices include on-board transient protection for all pins, permitting operation directly from a vehicle battery or regulator with supply voltages from 3.8 to 16 V.

Two package styles provide a choice of through-hole or surface mounting. Package type LH is a modified 3-pin SOT23W surface-mount package, while UA is a three-pin ultramini SIP for through-hole mounting. Both packages are lead (Pb) free and RoHS compliant, with 100% matte-tin-plated leadframes.

APPLICATIONS

- Seat/window motors
- Sun roof/convertible top/liftgate/tailgate actuation
- Automotive and industrial safety systems

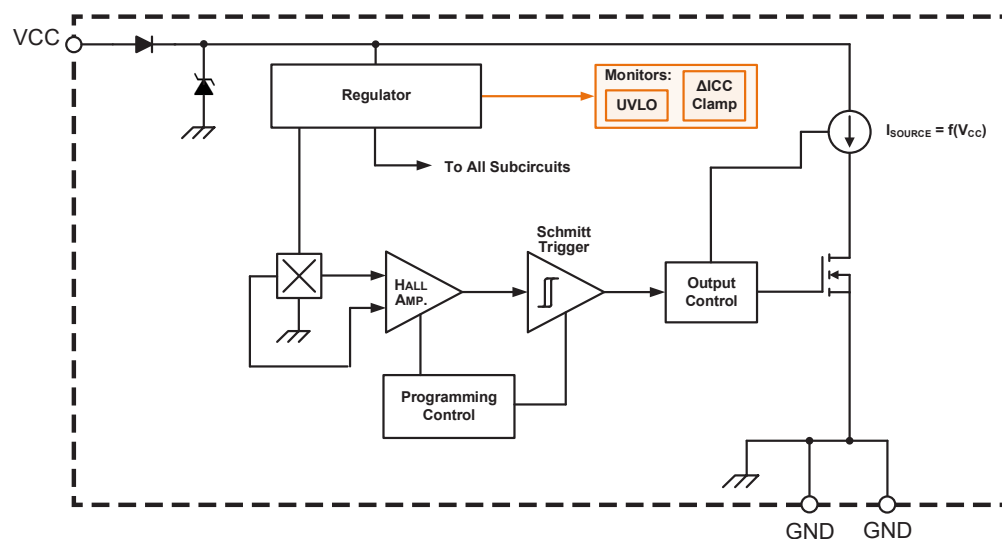

Functional Block Diagram

SELECTION GUIDE

Part Number	Packing ^[1]	Mounting	Branding	B _{RP} (Min)	B _{OP} (Max)
APS12170LLHALX	13-in. reel, 10000 pieces/reel	3-pin SOT23W surface mount	AAL	-175 G	175 G
APS12170LLHALT ^[2]	7-in. reel, 3000 pieces/reel	3-pin SOT23W surface mount			
APS12170LUAA	Bulk, 500 pieces/bag	3-pin SIP through hole			



^[1] Contact Allegro for additional packing options.

^[2] Available through authorized Allegro distributors only.

ABSOLUTE MAXIMUM RATINGS

Characteristic	Symbol	Notes	Rating	Units
Supply Voltage ^[1]	V _{CC}	T _J < T _{J(max)}	30	V
	V _{CCS}	1 minute, T _A = 85°C, I _{CC} = I _{CC(HIGH)} , R _{SENSE} = 182 ±1% (Ω)	24	V
		1 minute (jump start) T _A = 25°C, I _{CC} = I _{CC(HIGH)} , R _{SENSE} = 182 ±1% (Ω)	26	V
		0.5 seconds (load dump), T _A = 25°C, I _{CC} = I _{CC(HIGH)} , R _{SENSE} = 182 ±1% (Ω)	40	V
Reverse Supply Voltage ^[1]	V _{RCC}		-30	V
Forward Supply Current ^[1]	I _{CC}		52.5	mA
Reverse Supply Current ^[1]	I _{RCC}		-10	mA
Magnetic Flux Density ^[2]	B		Unlimited	-
Maximum Junction Temperature	T _{J(max)}		165	°C
		For 1000 hours	175	°C
Storage Temperature	T _{stg}		-65 to 170	°C

^[1] Unless specifically noted, this rating does not apply to extremely short voltage transients such as conducted immunity and/or ESD.

Those events have individual ratings, specific to the respective transient voltage event. Rating is based on anticipated performance.

^[2] Guaranteed by design.

ESD PERFORMANCE

Characteristic	Symbol	Notes	Rating	Units
ESD Voltage	V _{ESD(HBM)}	Human Body Model according to AEC-Q100-002	±12	kV

TRANSIENT PROTECTION CHARACTERISTICS: Valid for T_A = 25°C

Characteristic	Symbol	Test Conditions	Min.	Typ.	Max.	Units
Supply Zener Clamp Voltage	V _Z	I _{CC} = I _{CC(LOW)} + 1.0 mA	32	-	-	V
Supply Zener Current ^[1]	I _Z	V _Z = 32 V	-	-	10.5	mA
Reverse Supply Zener Clamp Voltage	V _{RZ}	I _{CC} = -0.5 mA	-	-	-30	V
Reverse Supply Current	I _{RCC}	V _{RCC} = -30 V	-10	-	-	mA

^[1] Maximum current limit is equal to the maximum I_{CC} + 3 mA.

PINOUT DIAGRAMS AND TERMINAL LIST TABLE

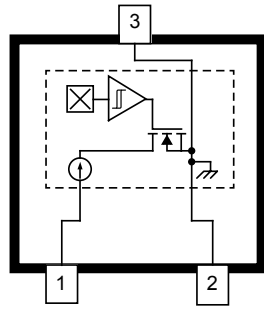

LH Package,
3-Pin SOT23W Pinout

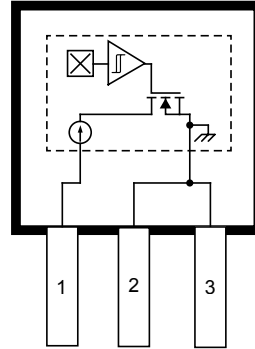

UA Package,
3-Pin SIP Pinout

Terminal List

Number	Package Name		Function [1]
	LH	UA	
1	VCC	VCC	Connects power supply to chip
2	GND	GND	Ground
3	GND	GND	Ground

[1] Pins 2 and 3 are tied together internally and the device will operate with either pin 2 or 3 grounded externally; however, grounding both pins externally will improve EMC robustness.

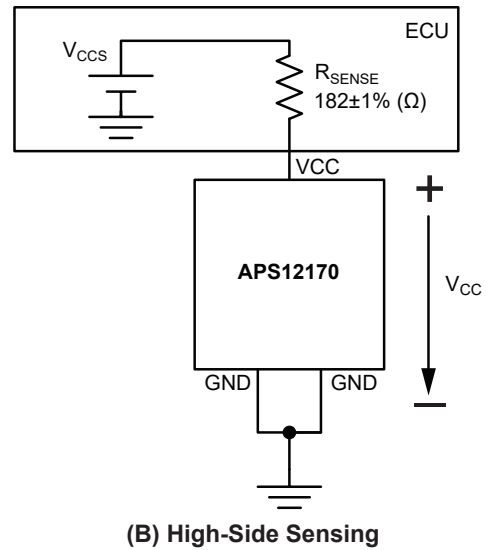
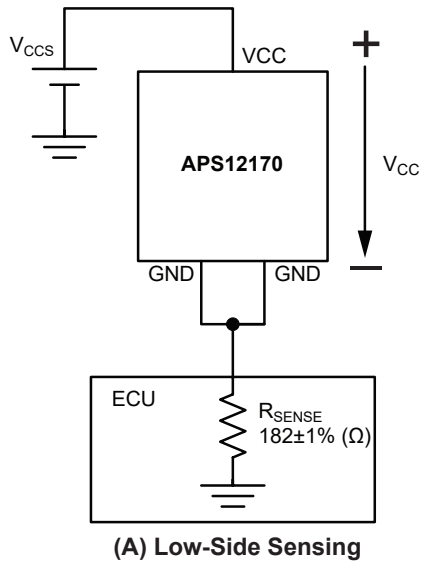

Figure 1: Typical Application Circuits

ELECTRICAL CHARACTERISTICS: Valid for $T_A = -40^{\circ}\text{C}$ to 150°C , unless otherwise specified

Characteristics	Symbol	Test Conditions	Min.	Typ. [1]	Max.	Unit	
ELECTRICAL CHARACTERISTICS							
Supply Voltage [2]	V_{CC}	UA, $T_J < 175^{\circ}\text{C}$	3.8	–	16	V	
		LH, $T_J < 175^{\circ}\text{C}$	3.8	–	13	V	
	V_{CCS} [3][8]	UA, $T_A = 25^{\circ}\text{C}$	UA, $T_A = 25^{\circ}\text{C}$	7	–	24	V
			LH, $T_A = 25^{\circ}\text{C}$	7	–	21	V
		UA, $T_A = -40^{\circ}\text{C}$ to 85°C	UA, $T_A = -40^{\circ}\text{C}$ to 85°C	7	–	19.5	V
			LH, $T_A = -40^{\circ}\text{C}$ to 85°C	7	–	16	V
		UA, $T_A = -40^{\circ}\text{C}$ to 110°C	UA, $T_A = -40^{\circ}\text{C}$ to 110°C	7	–	16	V
			LH, $T_A = -40^{\circ}\text{C}$ to 110°C	7	–	13	V
		UA, $T_A = -40^{\circ}\text{C}$ to 125°C , $I_{CC(HIGH)}$ Duty Cycle < 65%	UA, $T_A = -40^{\circ}\text{C}$ to 125°C , $I_{CC(HIGH)}$ Duty Cycle < 65%	7	–	16	V
			LH, $T_A = -40^{\circ}\text{C}$ to 125°C , $I_{CC(HIGH)}$ Duty Cycle < 65%	7	–	13	V
		UA, $T_A = -40^{\circ}\text{C}$ to 130°C , $I_{CC(HIGH)}$ for ≤ 250 hours (lifetime)	UA, $T_A = -40^{\circ}\text{C}$ to 130°C , $I_{CC(HIGH)}$ for ≤ 250 hours (lifetime)	7	–	16	V
			LH, $T_A = -40^{\circ}\text{C}$ to 130°C , $I_{CC(HIGH)}$ for ≤ 250 hours (lifetime)	7	–	13	V
Supply Current	$I_{CC(LOW)}$	$B < B_{RP}$	4.5	–	7.5	mA	
	$I_{CC(HIGH)}$	$B > B_{OP}$	–	$I_{CC(LOW)} + \Delta I_{CC}$	–	mA	
Proportional Supply Current [4][5]	ΔI_{CC}	$V_{CC} \leq 7.3\text{ V}$	–10%	$V_{CC} / 400\ \Omega$	10%	mA	
		$V_{CC} > 7.3\text{ V}$	–7%	$V_{CC} / 400\ \Omega$	7%	mA	
Proportional Current Clamp [5][6][7]	$\Delta I_{CCclamp}$	$V_{CC\Delta ICCL} < V_{CC} < V_{CC\Delta ICCH}$, Foldback Enabled, $T_A = 25^{\circ}\text{C}$	–	40	–	mA	
Proportional Current Clamp, Supply Voltage Level [5]	$V_{CC\Delta ICCH}$	V_{CC} increasing	–	19	21	V	
	$V_{CC\Delta ICCL}$	V_{CC} decreasing	16.5	18	–	V	
Power-On Time	t_{ON}	$B > B_{OP} + 5\text{ G}$ or $B < B_{RP} - 5\text{ G}$, $dV_{CC}/dt < 0.8\text{ V}/\mu\text{s}$	–	–	4	μs	
		$B > B_{OP} + 5\text{ G}$ or $B < B_{RP} - 5\text{ G}$	–	–	8	μs	
Power-On State, Output	POS	$V_{CC} \geq V_{CC(min)}$, $t < t_{ON}$	$I_{CC(HIGH)}$		–	–	
Undervoltage Lockout	V_{UVLO}	V_{CC} decreasing; for $V_{UVLO} < V_{CC} < V_{CC(min)}$, B_{OP} and B_{RP} are not guaranteed	–	2.5	–	V	
Power-Off Voltage	V_{SD}	V_{CC} decreasing; for $V_{SD} < V_{CC} < V_{UVLO}$, the device output is in the POS	–	2.25	–	V	
Output Response Time [8]	t_D	250 G step in 1 μs , 182 Ω R_{SENSE} only (low side)	–	3.3	5	μs	
Output Slew Rate, Rising [9][10]	dl/dt_{RISING}	$V_{CC} = 12\text{ V}$, $R_{SENSE} = 182 \pm 1\% \Omega$, $C_S = 12\text{ pF}$, No C_{BYP}	–	25	–	mA/ μs	
Output Slew Rate, Falling [9][10]	$dl/dt_{FALLING}$	$V_{CC} = 12\text{ V}$, $R_{SENSE} = 182 \pm 1\% \Omega$, $C_S = 12\text{ pF}$, No C_{BYP}	–	48	–	mA/ μs	

[1] Typical data are at $T_A = 25^{\circ}\text{C}$ and $V_{CC} = 12\text{ V}$, unless otherwise noted; for design information only.

[2] Maximum voltage must be adjusted for power dissipation and junction temperature, see Power Derating section.

[3] V_{CCS} is defined as $V_{CC} + V_{DROD}$ where V_{DROD} is $f(R_{SENSE})$, $R_{SENSE} = 182 \pm 1\% \Omega$, $I_{CC} = I_{CC(HIGH)}$.

[4] Measured as difference in high and low output states, $V_{CC} < V_{CC\Delta ICCH}$.

[5] Independent of external R_{SENSE} value.

[6] Set internally; independent of value of external R_{SENSE} .

[7] "Foldback enable" means foldback is enabled when $V_{CC} > V_{CC\Delta ICCH}$

[8] Guaranteed by device design and characterization.

[9] Change in current, dl , is the difference between 10% and 90% of $I_{CC(HIGH)} - I_{CC(LOW)}$; dt is the time period between those two points.

[10] C_S is the oscilloscope capacitance.

OPERATING CHARACTERISTICS: Valid over full operating voltage and ambient temperature ranges

Characteristics	Symbol	Test Conditions	Min.	Typ.	Max.	Unit [1]
MAGNETIC CHARACTERISTICS						
Operate Point	B _{OP}	South pole adjacent to branded face of device	50	–	175	G
Release Point	B _{RP}	North pole adjacent to branded face of device	–175	–	–50	G
Hysteresis	B _{HYS}	B _{OP} – B _{RP}	100	–	350	G
Offset	B _{OFF}	(B _{OP} + B _{RP}) / 2	–50	–	50	G

[1] 1 G (gauss) = 0.1 mT (millitesla).

THERMAL CHARACTERISTICS: May require derating at maximum conditions; see Applications section

Characteristic	Symbol	Test Conditions	Value	Units
Package Thermal Resistance	R _{θJA}	Package LH, 1-layer PCB with copper limited to solder pads	228	°C/W
		Package LH, 2-layer PCB with 0.463 in ² of copper area each side connected by thermal vias	110	°C/W
		Package UA, 1-layer PCB with copper limited to solder pads	165	°C/W

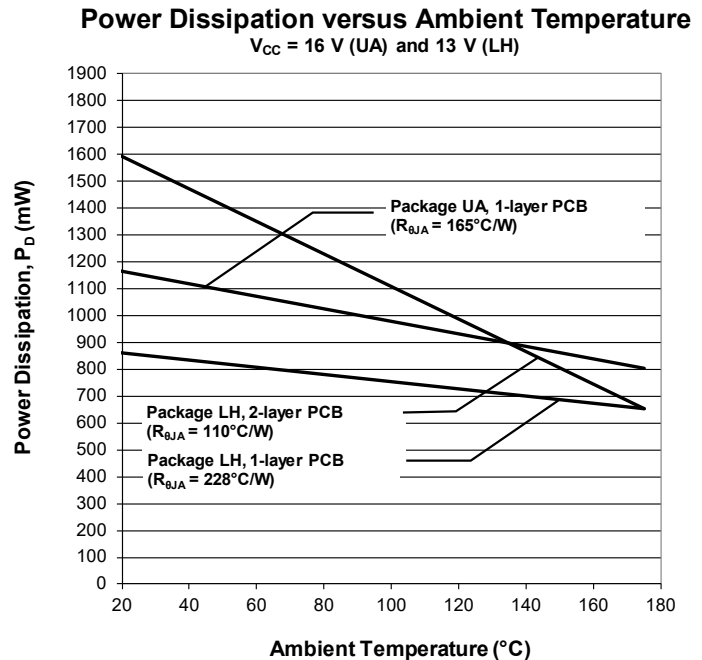
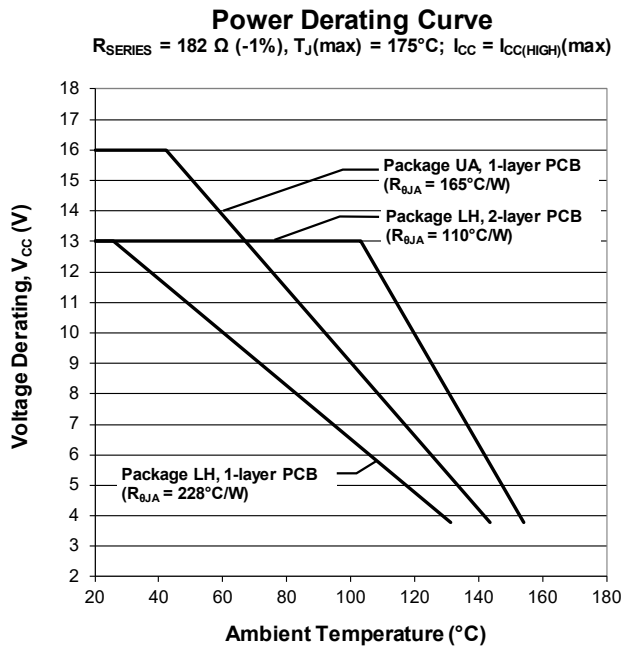

CHARACTERISTIC PERFORMANCE

Electrical Characteristics

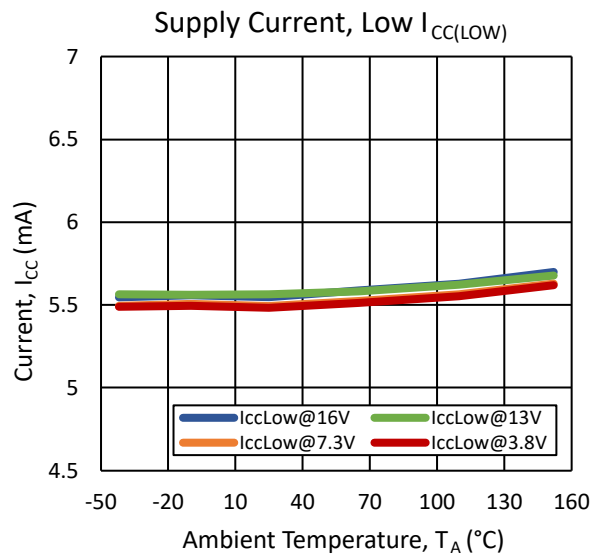
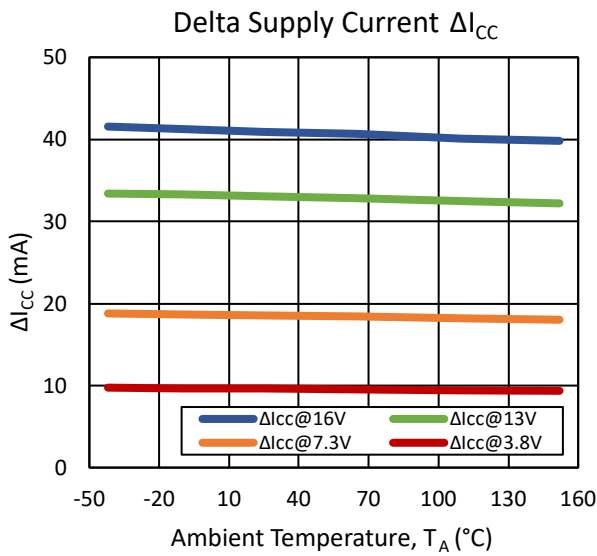
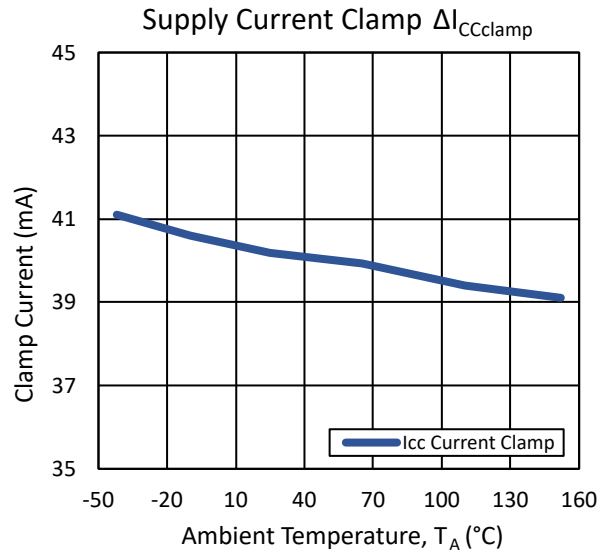
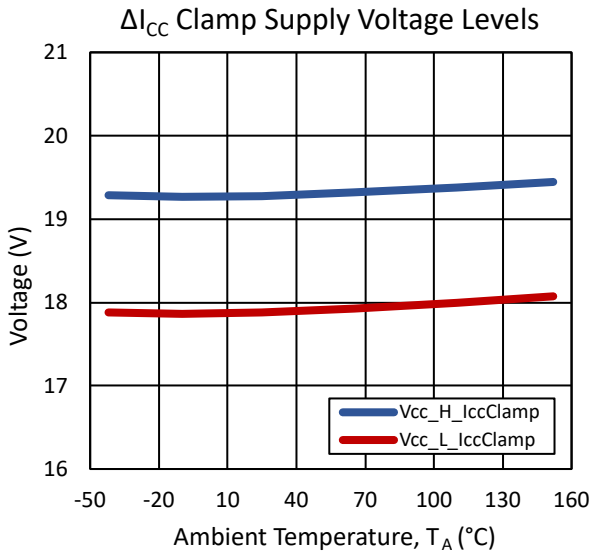

CHARACTERISTIC PERFORMANCE (continued)

Magnetic Characteristics

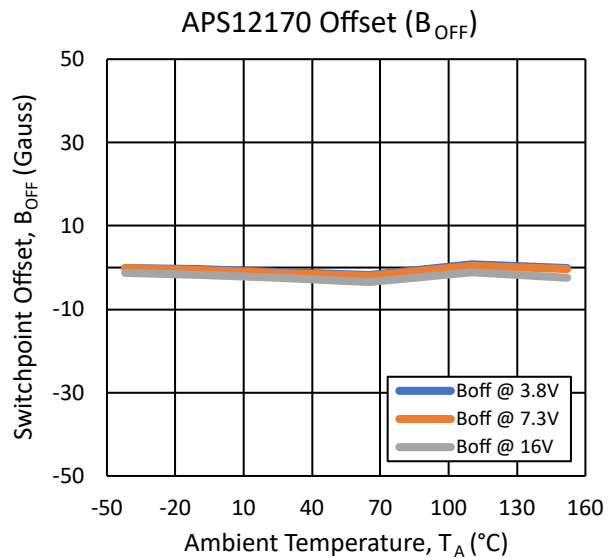
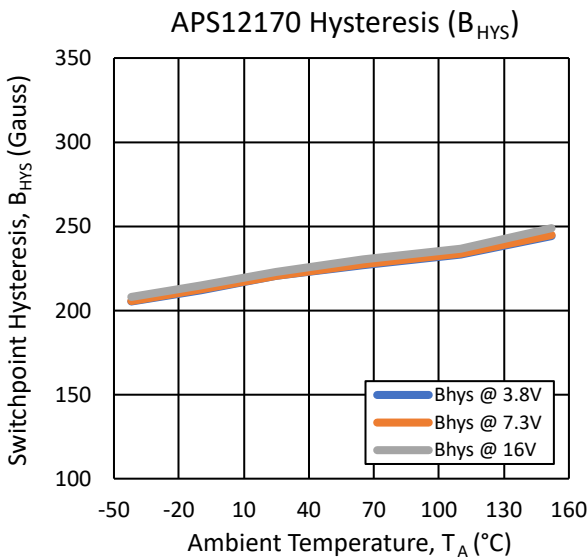
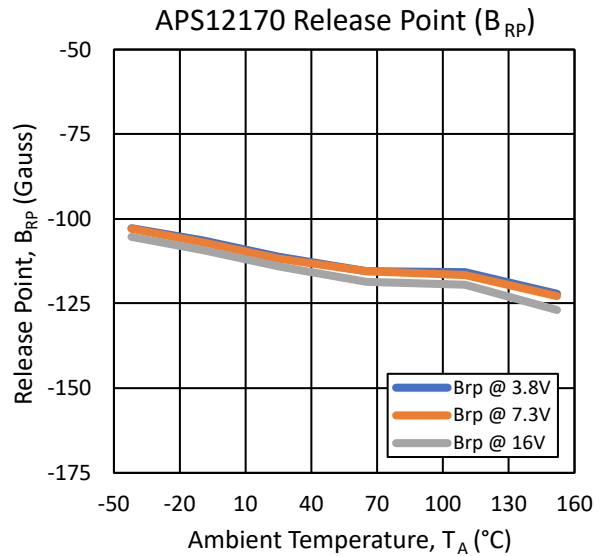
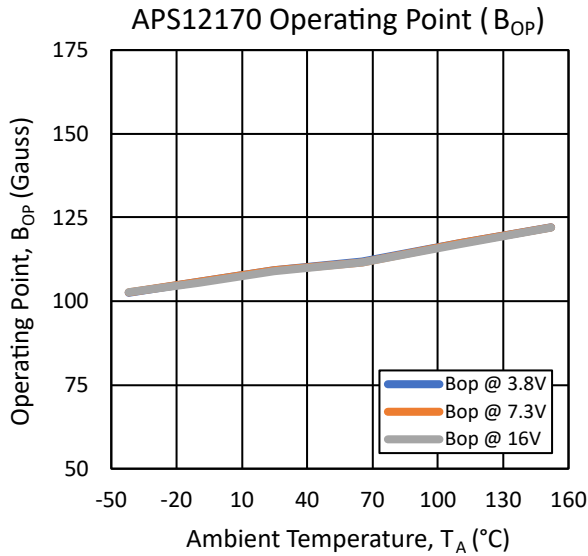

FUNCTIONAL DESCRIPTION

Operation

The output of these devices switches high to $I_{CC(HIGH)}$ when a magnetic field perpendicular to the Hall element exceeds the operate point threshold, B_{OP} (see Figure 2). When the magnetic field is reduced below the release point, B_{RP} , the device output goes low to $I_{CC(LOW)}$. The midpoint between B_{OP} and B_{RP} is denoted as the offset, B_{OFF} , of the device. A device with 0 G B_{OFF} indicates that $B_{OP} = -B_{RP}$. The difference in the magnetic operate and release points is the hysteresis, B_{HYS} , of the device. This built-in hysteresis allows clean switching of the output even in the presence of external mechanical vibration and electrical noise.

Removal of the magnetic field will leave the device output latched in $I_{CC(HIGH)}$ if the last crossed switch point is B_{OP} , or latched in $I_{CC(LOW)}$ if the last crossed switch point is B_{RP} .

Two-Wire Interface

The voltage-controlled current output is configured for two-wire applications, requiring one less wire for operation than switches with the traditional open-collector output. Additionally, the system designer inherently gains basic diagnostics because there is always output current flowing, which should be in either of two ranges under normal operation, shown in Figure 3 as $I_{CC(HIGH)}$ and $I_{CC(LOW)}$. Any current level not within these ranges indicates a fault condition.

If $I_{CC} > I_{CC(HIGH)(max)}$, then a short condition exists, and if $I_{CC} < I_{CC(LOW)(min)}$, then an open condition exists. Any value of I_{CC} between the allowed ranges for $I_{CC(HIGH)}$ and $I_{CC(LOW)}$ indicates a general fault condition. A user may choose to set a range of allowable supply current values based on the operating supply voltage. This unique two-wire interface protocol is backward compatible with legacy systems using two-wire switches.

Output Polarity

The output signal may be read as a voltage, V_{SENSE} , by using a sense resistor, R_{SENSE} , placed either in series with VCC or with GND (refer to Figure 1). When R_{SENSE} is placed in series with GND, the output signal voltage is in phase with I_{CC} . When R_{SENSE} is placed in series with VCC, the output signal voltage is inverted relative to I_{CC} . Table 1 lists possible combinations of sense resistor placement and resulting logic states.

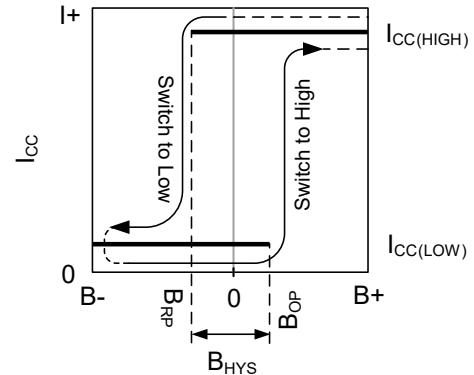

Figure 2: Switching Behavior of Latches

On the horizontal axis, the B+ direction indicates increasing south polarity magnetic field strength, and the B- direction indicates increasing north polarity field strength.

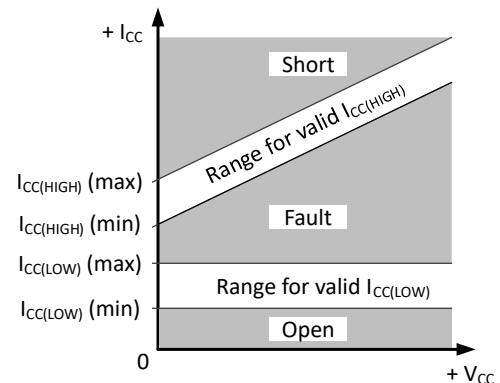

Figure 3: Diagnostic Characteristics of Supply Current Values

Table 1: Output Signal Polarity

R _{SENSE} Location (Refer to Figure 1)	I _{CC} State*	V _{SENSE} Logic State
High Side (VCC Pin Side)	High	Low
	Low	High
Low Side (GND Pin Side)	High	High
	Low	Low

* I_{CC} state High ($I_{CC(HIGH)}$) corresponds with $B > B_{OP}$ and Low ($I_{CC(LOW)}$) corresponds with $B < B_{RP}$.

POWER-ON/OFF BEHAVIOR

Device power-on occurs once t_{ON} has elapsed. During the time prior to t_{ON} , and after $V_{CC} \geq V_{CC(min)}$, the output state is $I_{CC(HIGH)}$. After t_{ON} has elapsed, the output will correspond with the applied magnetic field for $B > B_{OP}$ or $B < B_{RP}$. See Figure 4 for an example.

Powering-on the device in the hysteresis range (less than B_{OP} and higher than B_{RP}) will give an output state of $I_{CC(HIGH)}$. The cor-

rect state is attained after the first excursion beyond B_{OP} or B_{RP} .

During conditions where the supply voltage drops below $V_{CC(min)}$ but remains above V_{UVLO} , (e.g. $V_{UVLO} < V_{CC} < V_{CC(min)}$), the IC will continue to switch, however B_{OP}/B_{RP} specifications are not guaranteed. The region between the V_{UVLO} and V_{SD} thresholds is where the IC will disengage operation of the output and revert to the power-on state. If the supply voltage falls below V_{SD} , the output will become invalid and the device turns off.

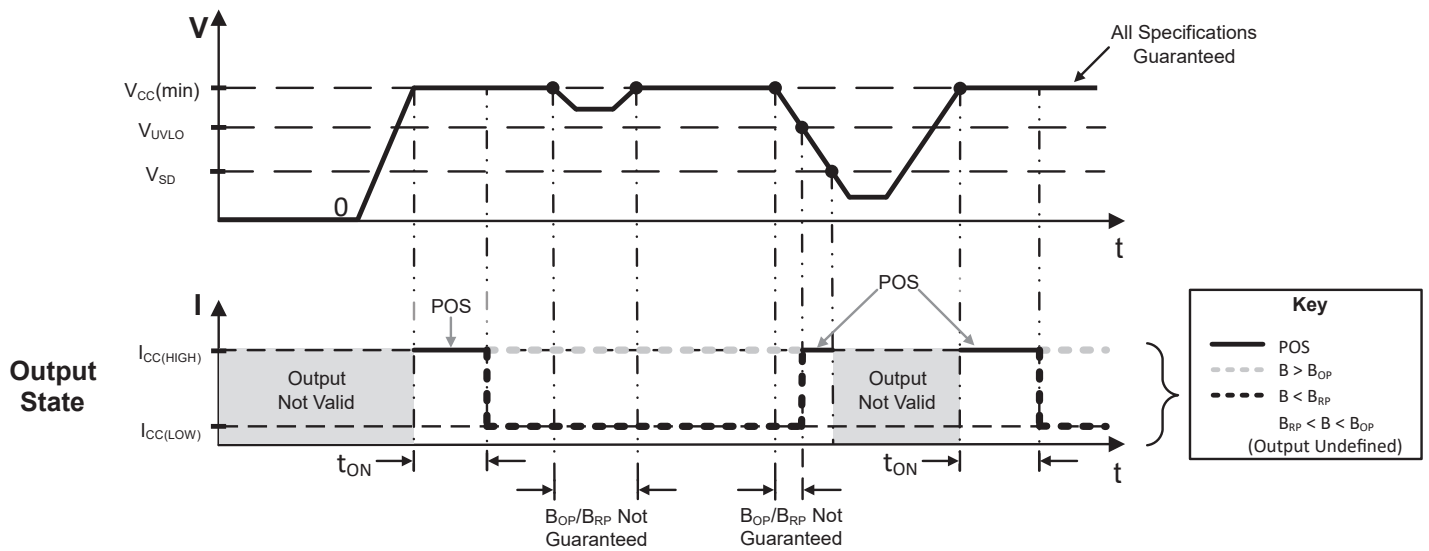

Figure 4: Power-On and Power-Off Timing Diagram

APPLICATIONS

The APS12170 has a current mode output that corresponds with the plot in Figure 5. The high supply current level, $I_{CC(HIGH)}$, is a function of the system supply voltage, V_{CCS} , and the supply voltage across the device pins, V_{CC} . The low supply current level, $I_{CC(LOW)}$, is regulated to within a narrow range of 4.5 to 7.5 mA.

These devices are sensitive in the direction perpendicular to the branded face, as depicted in Figure 6.

For further information, extensive applications information on magnets and Hall-effect sensors is available in:

- *Hall-Effect IC Applications Guide, AN27701,*
- *Hall-Effect Devices: Guidelines for Designing Subassemblies Using Hall-Effect Devices AN27703.1*
- *Soldering Methods for Allegro’s Products – SMD and Through-Hole, AN26009*
- *Digital Position Sensor ICs—Continuous-Time to Chopper-Stabilized Cross-Reference Guide, AN296125*

All are provided on the Allegro website:

<https://www.allegromicro.com/en/insights-and-innovations>

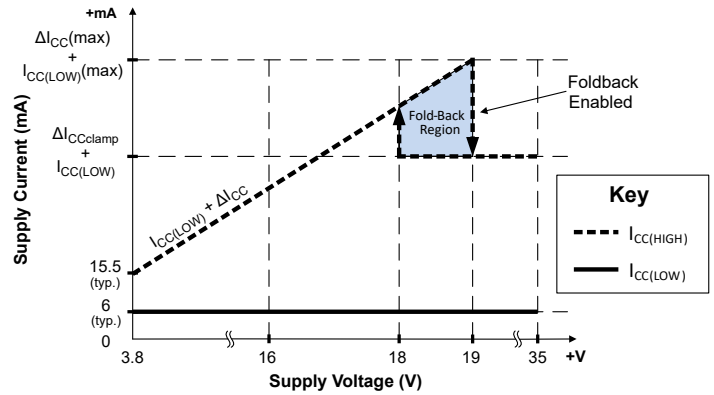

Figure 5: Supply Current Diagram (using circuits shown in Figure 1)

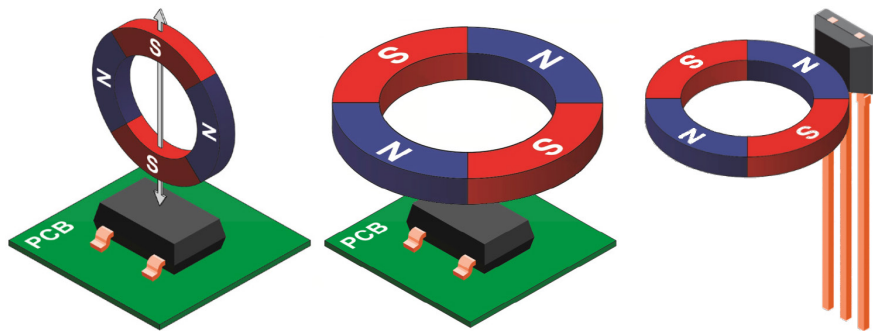

Figure 6: Sensing Configurations

CONTINUOUS-TIME BENEFITS

Continuous-time devices, such as the APS12170, offer the fastest available power-on settling time and frequency response. Battery management is an example where continuous-time is often required. In these applications, V_{CC} is duty-cycled with a very small duty cycle in order to conserve power (refer to Figure 7). The duty cycle is controlled by the power-on time, t_{ON} , of the device. Because continuous-time devices have the fastest power-on time, compared to their chopper-stabilized counterpart, they are the clear choice for such applications.

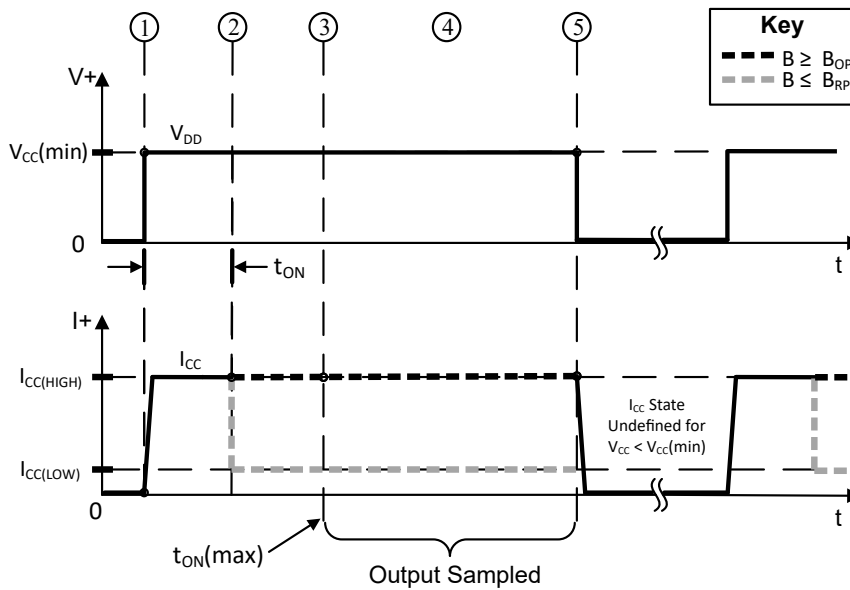

Figure 7: Continuous Time Operation Example

This figure illustrates the use of a technique which duty-cycles the VCC power supply in order to conserve battery power

- ① Power is applied to the device.
- ② The output assumes a valid state at a time prior to the maximum Power-on Time, $t_{ON(max)}$.
- ③ The maximum power on time, $t_{ON(max)}$, has elapsed the device output is now valid.
- ④ After the output is valid, the control unit reads the output.
- ⑤ Power is removed from the device.

POWER DERATING

The device must be operated below the maximum junction temperature of the device, $T_J(\text{max})$. Under certain combinations of peak conditions, reliable operation may require derating supplied power or improving the heat dissipation properties of the application. This section presents a procedure for correlating factors affecting operating T_J . (Thermal data is also available on the Allegro MicroSystems website.)

Thermal Resistance (junction to ambient), $R_{\theta JA}$, is a figure of merit summarizing the ability of the application and the device to dissipate heat from the junction (die), through all paths to the ambient air. Its primary component is the Effective Thermal Conductivity, K , of the printed circuit board, including adjacent devices, traces, and board layout. Thermal resistance from the die junction to the device case, $R_{\theta JC}$, is a relatively small component of $R_{\theta JA}$. Ambient air temperature, T_A , and air motion are significant external factors in determining a reliable thermal operating point.

The APS12170 is permitted to operate up to $T_J = 175^\circ\text{C}$. An operating device will increase T_J according to equations 1, 2, and 3 below. This allows an estimation of the maximum ambient operating temperature.

$$P_D = V_{IN} \times I_{IN} \tag{1}$$

$$\Delta T = P_D \times R_{\theta JA} \tag{2}$$

$$T_J = T_A + \Delta T \tag{3}$$

For example, given common conditions such as: $T_A = 25^\circ\text{C}$, $V_{CC} = 12\text{ V}$, $I_{CC} = 6\text{ mA}$, and $R_{\theta JA} = 165^\circ\text{C/W}$, then:

$$P_D = (V_{CC} \times I_{CC}) = (12\text{ V} \times 6\text{ mA}) = 72\text{ mW}$$

$$\Delta T = P_D \times R_{\theta JA} = 72\text{ mW} \times 165^\circ\text{C/W} = 11.9^\circ\text{C}$$

$$T_J = T_A + \Delta T = 25^\circ\text{C} + 11.9^\circ\text{C} = 36.9^\circ\text{C}$$

A worst-case estimate for the maximum ambient temperature permitted during operation can be completed by considering the maximum die junction temperature and thermal components.

For example, given the conditions $R_{\theta JA} = 228^\circ\text{C/W}$, $T_J(\text{max}) = 175^\circ\text{C}$, $V_{CC}(\text{max}) = 13\text{ V}$, $I_{CC}(\text{max}) = 42.3\text{ mA}$, the power dissipation required for the IC supply is shown below:

$$P_D = V_{CC} \times I_{CC} = 13\text{ V} \times 42.3\text{ mA} = 550\text{ mW}$$

Next, by inverting using equation 2:

$$\Delta T = P_D \times R_{\theta JA} = 550\text{ mW} \times 228^\circ\text{C/W} = 125.4^\circ\text{C}$$

Finally, by inverting equation 3 with respect to voltage:

$$T_A(\text{est}) = T_J(\text{max}) - \Delta T = 175^\circ\text{C} - 125.4^\circ\text{C} = 49.6^\circ\text{C}$$

In the above case, there is sufficient power dissipation capability to operate up to $T_A(\text{est})$. The example indicates that $T_A(\text{max})$ can be as high as 49.6°C without exceeding $T_J(\text{max})$. However, the $T_A(\text{max})$ rating of the devices is 150°C ; the APS12170 performance is not guaranteed above $T_A = 150^\circ\text{C}$.

Package LH, 3-Pin (SOT-23W)

For Reference Only – Not for Tooling Use

(Reference Allegro DWG-0000628, Rev. 1)

NOT TO SCALE

Dimensions in millimeters

Dimensions exclusive of mold flash, gate burrs, and dambar protrusions
Exact case and lead configuration at supplier discretion within limits shown

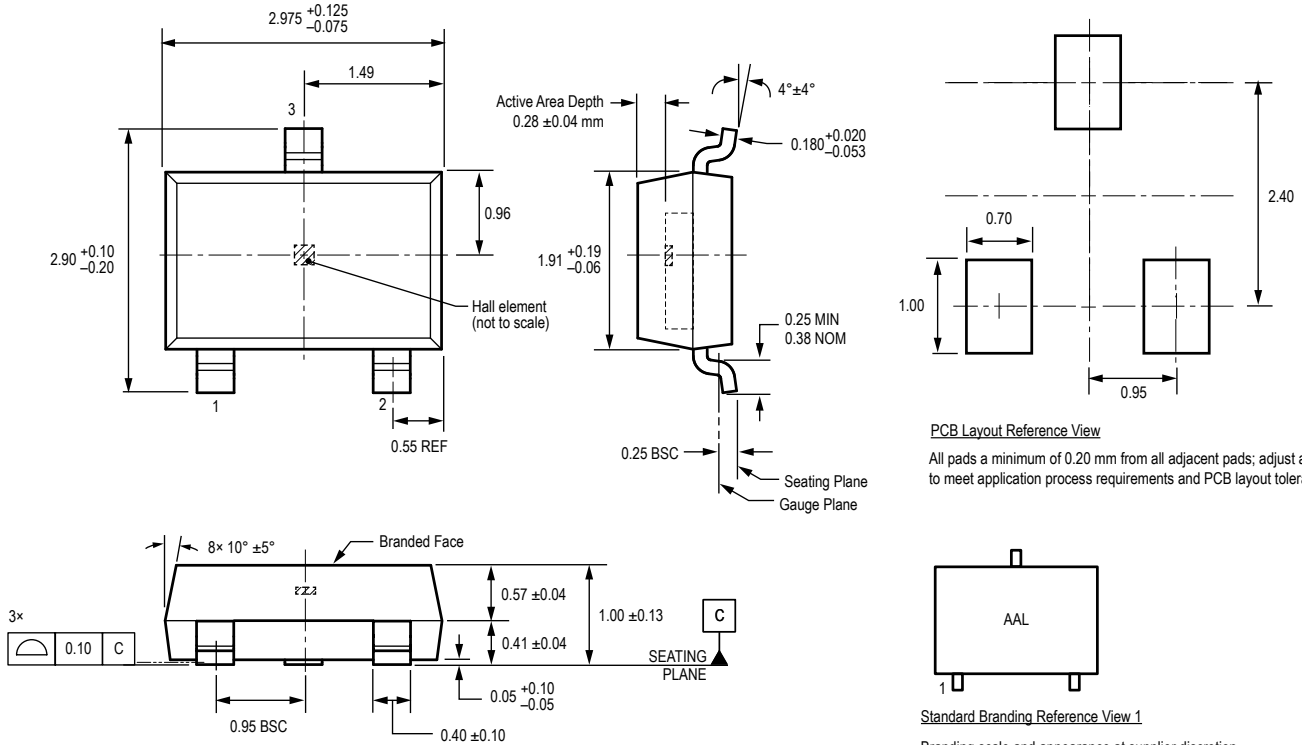

PCB Layout Reference View

All pads a minimum of 0.20 mm from all adjacent pads; adjust as necessary to meet application process requirements and PCB layout tolerances

Standard Branding Reference View 1

Branding scale and appearance at supplier discretion

Package UA, 3-Pin SIP

For Reference Only – Not For Tooling Use

(Reference DWG-0000404, Rev. 1)

NOT TO SCALE

Dimensions in millimeters

Exact case and lead configuration at supplier discretion within limits shown

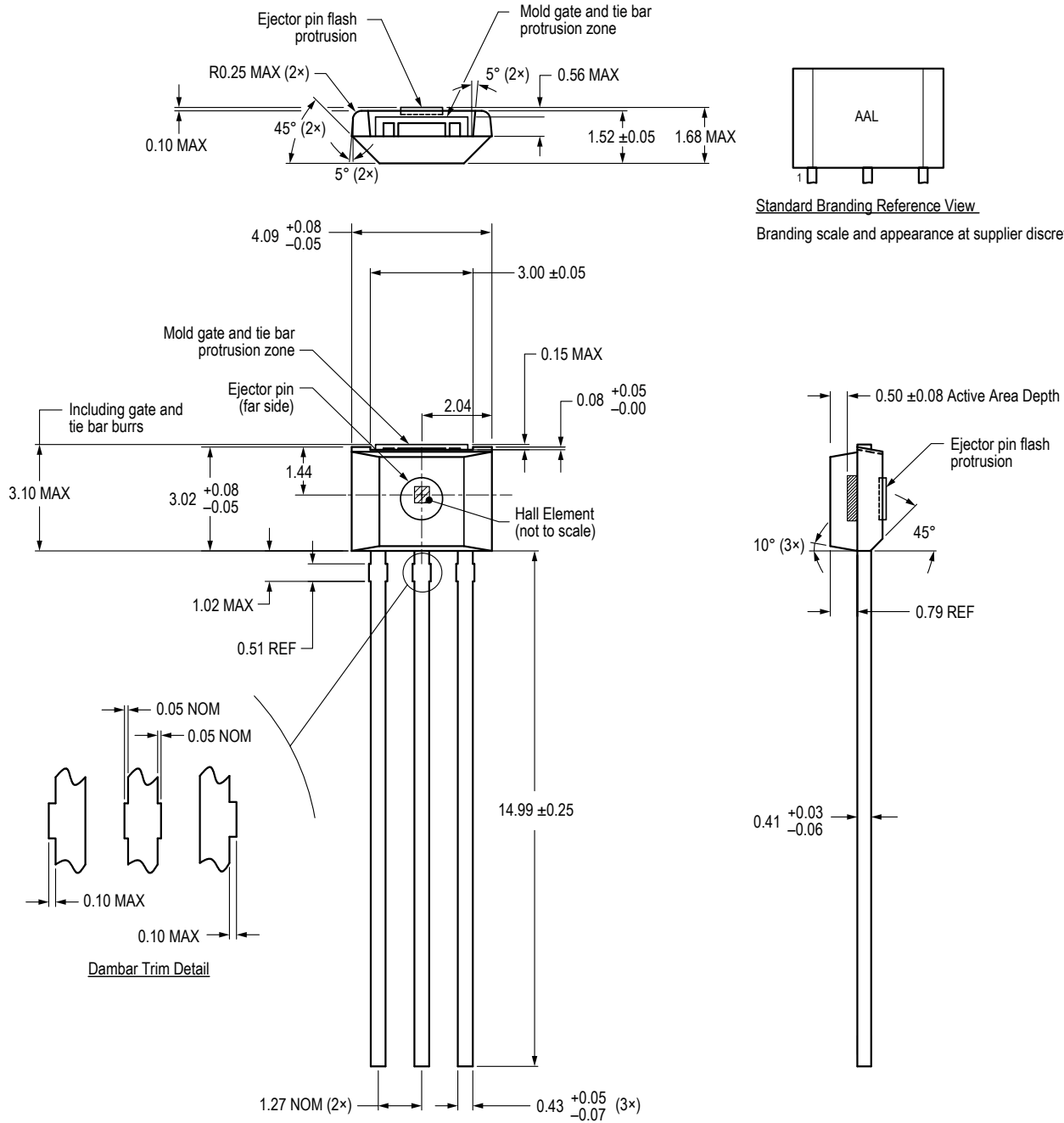

Standard Branding Reference View

Branding scale and appearance at supplier discretion

Revision History

Number	Date	Description
–	February 24, 2021	Initial release
1	February 21, 2022	Updated package drawings (pages 13-14)

Copyright 2022, Allegro MicroSystems.

Allegro MicroSystems reserves the right to make, from time to time, such departures from the detail specifications as may be required to permit improvements in the performance, reliability, or manufacturability of its products. Before placing an order, the user is cautioned to verify that the information being relied upon is current.

Allegro's products are not to be used in any devices or systems, including but not limited to life support devices or systems, in which a failure of Allegro's product can reasonably be expected to cause bodily harm.

The information included herein is believed to be accurate and reliable. However, Allegro MicroSystems assumes no responsibility for its use; nor for any infringement of patents or other rights of third parties which may result from its use.

Copies of this document are considered uncontrolled documents.

For the latest version of this document, visit our website:

www.allegromicro.com

Looking for pricing, stock, or lifecycle information?

Click below to explore more details on WIN SOURCE:

- ⊖ [View APS12170LUAATN on WIN SOURCE](#)
- ⊖ [Allegro MicroSystems, LLC Information](#)

Optimize Your Supply Chain with WIN SOURCE Solutions

- ✓ Global Sourcing Solution
- ✓ Obsolete Management
- ✓ Cost Control Management
- ✓ Shortage Management
- ✓ Alternative Solution
- ✓ Excess Inventory Management