



THE DATASHEET OF FT232RNQ-TRAY



Future Technology Devices International Ltd.

FT232RN



The FT232RN is a USB to serial UART interface with the following advanced features:

- Single chip USB to asynchronous serial data transfer interface.
- Entire USB protocol handled on the chip. No USB specific firmware programming required.
- Fully integrated 1024-bit EEPROM storing device descriptors and CBUS I/O configuration.
- Fully integrated USB termination resistors.
- Fully integrated clock generation with no external crystal required plus optional clock output selection enabling a glue-less interface to external MCU or FPGA.
- Data transfer rates from 300 baud to 3 Mbaud (RS422, RS485, RS232) at TTL levels.
- 128 bytes receive buffer, and 256 bytes transmit buffer utilising buffer smoothing technology to allow for high data throughput.
- FTDI's royalty-free Virtual Com Port (VCP) and Direct (D2XX) drivers eliminate the requirement for USB driver development in most cases.
- Unique USB FTDIChip-ID™ feature.
- Configurable CBUS I/O pins.
- Transmit and receive LED drive signals.
- UART interface support for 7 or 8 data bits, 1 or 2 stop bits and odd / even / mark / space / no parity
- FIFO receives and transmits buffers for high data throughput.
- Synchronous and asynchronous bit bang interface options with RD# and WR# strobes.
- Device supplied pre-programmed with unique USB serial number.
- Supports bus powered, self-powered and high-power bus powered USB configurations.
- Integrated +3.3V level converter for USB I/O.
- Integrated level converter on UART and CBUS for interfacing to between +1.8V and +5V logic.
- True 5V/3.3V/2.8V/1.8V CMOS drive output and TTL input.
- Configurable I/O pin output drive strength.
- Integrated power-on-reset circuit.
- Fully integrated AVCC supply filtering - no external filtering required.
- UART signal inversion option.
- +3.3V to +5.25V Single Supply Operation.
- Low operating and USB suspend current.
- Low USB bandwidth consumption.
- UHCI/OHCI/EHCI host controller compatible.
- USB 2.0 Full Speed compatible.
- -40°C to 85°C extended operating temperature range.
- Available in compact Pb-free 28 Pin SSOP and QFN-32 packages (both RoHS compliant).

Neither the whole nor any part of the information contained in, or the product described in this manual, may be adapted, or reproduced in any material or electronic form without the prior written consent of the copyright holder. This product and its documentation are supplied on an as-is basis and no warranty as to their suitability for any particular purpose is either made or implied. Future Technology Devices International Ltd will not accept any claim for damages howsoever arising as a result of use or failure of this product. Your statutory rights are not affected. This product or any variant of it is not intended for use in any medical appliance, device, or system in which the failure of the product might reasonably be expected to result in personal injury. This document provides preliminary information that may be subject to change without notice. No freedom to use patents or other intellectual property rights is implied by the publication of this document. Future Technology Devices International Ltd, Unit 1, 2 Seaward Place, Centurion Business Park, Glasgow G41 1HH United Kingdom. Scotland Registered Company Number: SC136640

1 Typical Applications

- USB to RS232/RS422/RS485 Converters
- Upgrading Legacy Peripherals to USB
- Cellular and Cordless Phone USB data transfer cables and interfaces
- Interfacing MCU/PLD/FPGA based designs to USB
- USB Audio and Low Bandwidth Video data transfer
- PDA to USB data transfer
- USB Smart Card Readers
- USB Instrumentation
- USB Industrial Control
- USB MP3 Player Interface
- USB FLASH Card Reader and Writers
- Set Top Box PC - USB interface
- USB Digital Camera Interface
- USB Hardware Modems
- USB Wireless Modems
- USB Bar Code Readers
- USB Software and Hardware Encryption Dongles

1.1 Driver Support

Royalty free VIRTUAL COM PORT (VCP) DRIVERS for...

- Windows 11,64-bit
- Windows 10 32,64-bit
- Windows 8/8.1 32,64-bit
- Windows 7 32,64-bit
- Windows Server 2008 and Server 2012 R2
- Mac OS
- Linux 2.4 and greater

Royalty free D2XX *Direct Drivers* (USB Drivers + DLL S/W Interface)

- Windows 11,64-bit
- Windows 10 32,64-bit
- Windows 8/8.1 32,64-bit
- Windows 7 32,64-bit
- Server 2008 and Server 2012 R2
- Mac OS
- Linux 2.4 and greater
- Android(J2xx)

The drivers listed above are all available to download for free from FTDI website (www.ftdichip.com). Various 3rd party drivers are also available for other operating systems - see FTDI website (www.ftdichip.com) for details.

For driver installation, please refer to <http://www.ftdichip.com/Documents/InstallGuides.htm>

1.2 Part Numbers

Part Number	Package
FT232RNQ-xxxx	32 Pin QFN
FT232RNL-xxxx	28 Pin SSOP

Note: Packing codes for xxxx is:

- Reel: Taped and Reel, (SSOP is 2,000pcs per reel, QFN is 6,000pcs per reel).
- Tube: Tube packing, 47pcs per tube (SSOP only)
- Tray: Tray packing, 490pcs per tray (QFN only)

For example: FT232RNQ-Reel is 6,000pcs taped and reel packing

1.3 USB Compliant

The FT232RN is fully compliant with the USB 2.0 specification and has been given the USB-IF Test-ID (TID) 6654.



2 FT232RN Block Diagram

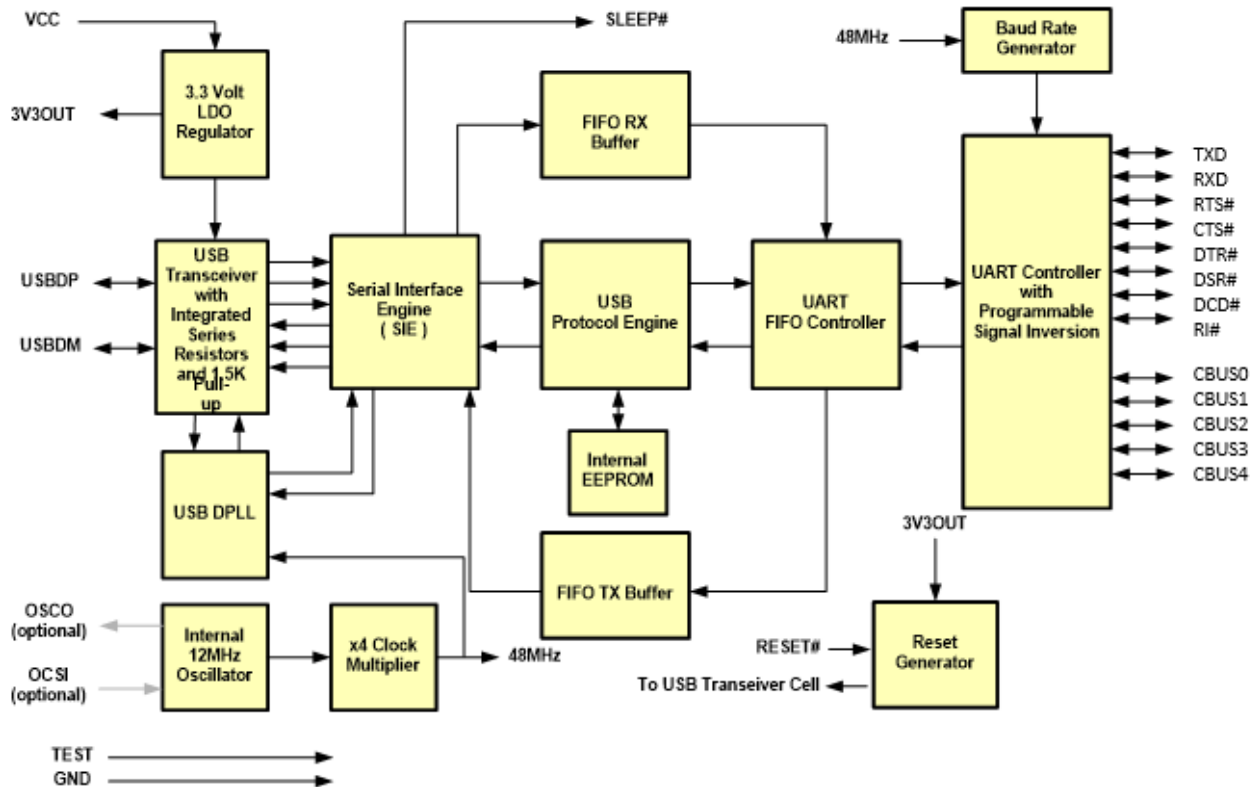

Figure 2.1 FT232RN Block Diagram

For a description of each function please refer to Section 4.

Table of Contents

1	Typical Applications.....	2
1.1	Driver Support.....	2
1.2	Part Numbers	2
1.3	USB Compliant.....	3
2	FT232RN Block Diagram	4
3	Device Pin Out and Signal Description.....	7
3.1	28-LD SSOP Package	7
3.2	SSOP Package Pin Out Description	7
3.3	QFN-32 Package	9
3.4	QFN-32 Package Signal Description.....	9
3.5	CBUS Signal Options.....	10
4	Function Description	12
4.1	Key Features	12
4.2	Functional Block Descriptions.....	13
5	Devices Characteristics and Ratings	15
5.1	Absolute Maximum Ratings	15
5.2	DC Characteristics	15
5.3	EEPROM Reliability Characteristics	17
5.4	Internal Clock Characteristics	17
5.5	Thermal Characteristics.....	18
6	USB Power Configurations.....	19
6.1	USB Bus Powered Configuration	19
6.2	Self Powered Configuration	20
6.3	USB Bus Powered with Power Switching Configuration.....	21
6.4	USB Bus Powered with Selectable External Logic Supply	22
7	Application Examples	24
7.1	USB to RS232 Converter	24
7.2	USB to RS485 Converter	25
7.3	USB to RS422 Converter	26
7.4	USB to MCU UART Interface.....	27

7.5 LED Interface	28
7.6 Using the External Oscillator	29
8 Internal EEPROM Configuration	30
9 Package Parameters.....	31
9.1 SSOP-28 Package Dimension.....	31
9.2 QFN-32 Package Dimensions	32
9.3 Solder Reflow Profile.....	33
10 Alternative Parts	35
11 Contact Information	36
Appendix A – References	37
Document References	37
Acronyms and Abbreviations.....	37
Appendix B – List of Figures and Tables.....	38
List of Figures	38
List of Tables.....	38
Appendix C – Revision History	40

3 Device Pin Out and Signal Description

3.1 28-LD SSOP Package

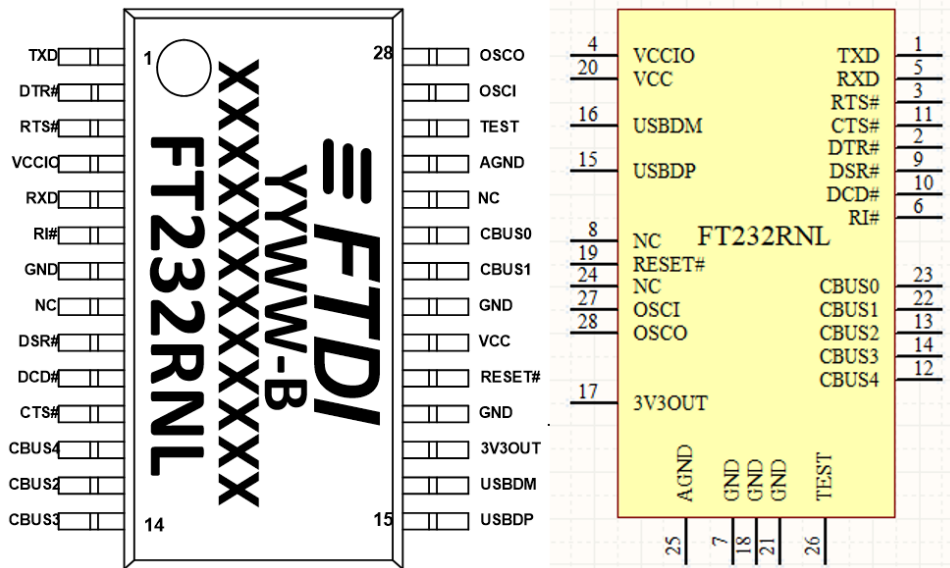

Figure 3.1 SSOP Package Pin Out and Schematic Symbol

3.2 SSOP Package Pin Out Description

Note: The convention used throughout this document for active low signals is the signal name followed by #

Pin No.	Name	Type	Description
15	USB DP	I/O	USB Data Signal Plus, incorporating internal series resistor and 1.5kΩ pull up resistor to 3.3V.
16	USB DM	I/O	USB Data Signal Minus, incorporating internal series resistor.

Table 3.1 USB Interface Group

Pin No.	Name	Type	Description
4	VCCIO	PWR	+1.8V to +5.25V supply to the UART Interface and CBUS group pins (1...3, 5, 6, 9...14, 22, 23). In USB bus powered designs connect this pin to 3V3OUT pin to drive out at +3.3V levels or connect to VCC to drive out at 5V CMOS level. This pin can also be supplied with an external +1.8V to +2.8V supply to drive outputs at lower levels. It should be noted that in this case this supply should originate from the same source as the supply to VCC. This means that in bus powered designs a regulator which is supplied by the +5V on the USB bus should be used.
7, 18, 21	GND	PWR	Device ground supply pins
17	3V3OUT	Output	+3.3V output from integrated LDO regulator. This pin should be decoupled to ground using a 100nF capacitor. The main usage of this pin is to provide the internal +3.3V supply to the USB transceiver cell and the internal 1.5kΩ pull up resistor on USB DP. Up to 50mA can be drawn from this pin to power external logic if required. This pin can also be used to supply the VCCIO pin.
20	VCC	PWR	+3.3V to +5.25V supply to the device core.
25	AGND	PWR	Device analogue ground supply for internal clock multiplier

Table 3.2 Power and Ground Group

Pin No.	Name	Type	Description
8, 24	NC	NC	No internal connection
19	RESET#	Input	Active low reset pin. This can be used by an external device to reset the FT232RN. If not required can be left unconnected or pulled up to VCC.
26	TEST	Input	Puts the device into IC test mode. Must be tied to GND for normal operation, otherwise the device will appear to fail.
27	OSCI	Input	Input 12MHz Oscillator Cell. Optional – Can be left unconnected for normal operation. (See Note 1)
28	OSCO	Output	Output from 12MHZ Oscillator Cell. Optional – Can be left unconnected for normal operation if internal Oscillator is used. (See Note 1)

Table 3.3 Miscellaneous Signal Group

Pin No.	Name	Type	Description
1	TXD	Output	Transmit Asynchronous Data Output.
2	DTR#	Output	Data Terminal Ready Control Output / Handshake Signal.
3	RTS#	Output	Request to Send Control Output / Handshake Signal.
5	RXD	Input	Receiving Asynchronous Data Input.
6	RI#	Input	Ring Indicator Control Input. When remote wake up is enabled in the internal EEPROM taking RI# low (20ms active low pulse) can be used to resume the PC USB host controller from suspend.
9	DSR#	Input	Data Set Ready Control Input / Handshake Signal.
10	DCD#	Input	Data Carrier Detect Control Input.
11	CTS#	Input	Clear To Send Control Input / Handshake Signal.
12	CBUS4	I/O	Configurable CBUS output only Pin. Function of this pin is configured in the device internal EEPROM. Factory default configuration is SLEEP#. See CBUS Signal Options, Table 3.9.
13	CBUS2	I/O	Configurable CBUS I/O Pin. Function of this pin is configured in the device internal EEPROM. Factory default configuration is TXDEN. See CBUS Signal Options, Table 3.9.
14	CBUS3	I/O	Configurable CBUS I/O Pin. Function of this pin is configured in the device internal EEPROM. Factory default configuration is PWREN#. See CBUS Signal Options, Table 3.9. PWREN# should be used with a 10kΩ resistor pull up.
22	CBUS1	I/O	Configurable CBUS I/O Pin. Function of this pin is configured in the device internal EEPROM. Factory default configuration is RXLED#. See CBUS Signal Options, Table 3.9.
23	CBUS0	I/O	Configurable CBUS I/O Pin. Function of this pin is configured in the device internal EEPROM. Factory default configuration is TXLED#. See CBUS Signal Options, Table 3.9.

Table 3.4 UART Interface and CUSB Group (see note 2)
Notes:

1. For details on how to use an external crystal, ceramic resonator, or oscillator with the FT232RN, please refer Section 7.6
2. When used in Input Mode, the input pins are pulled to VCCIO via internal 200kΩ resistors. These pins can be programmed to gently pull low during USB suspend (PWREN# = "1") by setting an option in the internal EEPROM.

3.3 QFN-32 Package

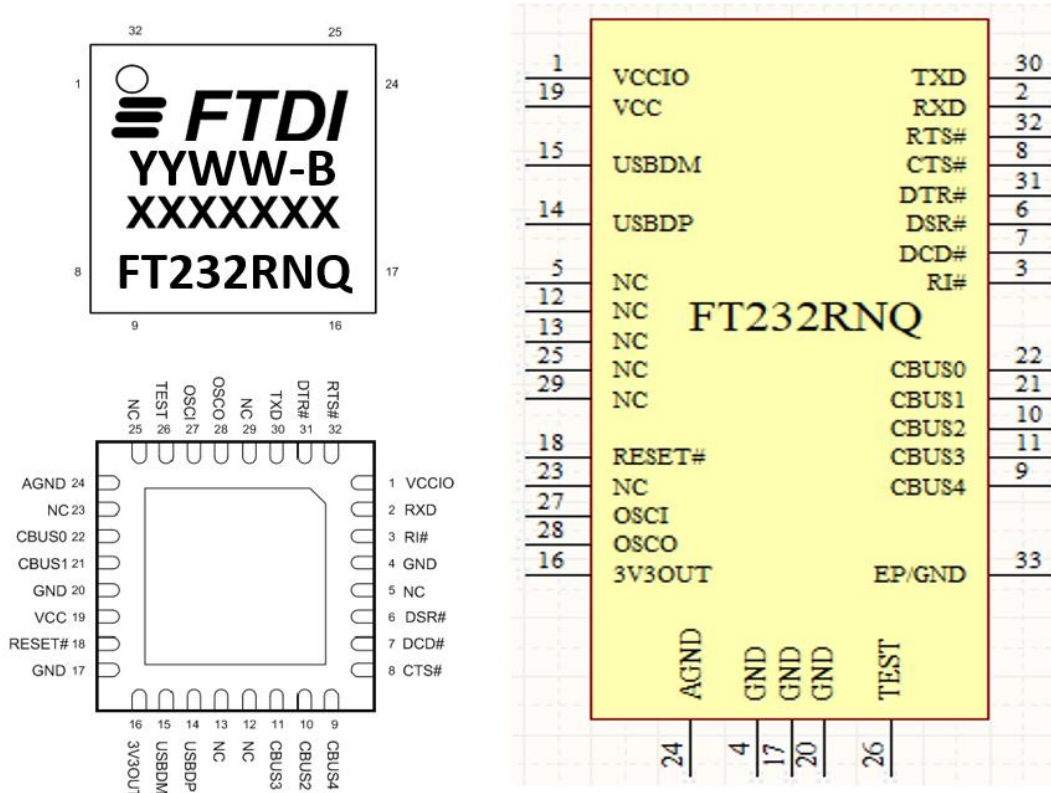

Figure 3.2 QFN-32 Package Pin Out and schematic symbol

3.4 QFN-32 Package Signal Description

Pin No.	Name	Type	Description
14	USBDP	I/O	USB Data Signal Plus, incorporating internal series resistor and 1.5kΩ pull up resistor to +3.3V.
15	USBDM	I/O	USB Data Signal Minus, incorporating internal series resistor.

Table 3.5 USB Interface Group

Pin No.	Name	Type	Description
1	VCCIO	PWR	+1.8V to +5.25V supply for the UART Interface and CBUS group pins (2,3,6,7,8,9,10,11,21,22,30,31,32). In USB bus powered designs connect this pin to 3V3OUT to drive out at +3.3V levels or connect to VCC to drive out at +5V CMOS level. This pin can also be supplied with an external +1.8V to +2.8V supply to drive out at lower levels. It should be noted that in this case this supply should originate from the same source as the supply to VCC. This means that in bus powered designs a regulator which is supplied by the +5V on the USB bus should be used.
4, 17, 20	GND	PWR	Device ground supply pins.
16	3V3OUT	Output	+3.3V output from integrated LDO regulator. This pin should be decoupled to ground using a 100nF capacitor. The purpose of this output is to provide the internal +3.3V supply to the USB transceiver cell and the internal 1.5kΩ pull up resistor on USBDP. Up to 50mA can be drawn from this pin to power external logic if required. This pin can also be used to supply the VCCIO pin.
19	VCC	PWR	+3.3V to +5.25V supply to the device core. .
24	AGND	PWR	Device analogue ground supply for internal clock multiplier.

Table 3.6 Power and Ground Group

Pin No.	Name	Type	Description
5, 12, 13, 23, 25, 29	NC	NC	No internal connection. Do not connect.
18	RESET#	Input	Active low reset. Can be used by an external device to reset the FT232RN. If not required can be left unconnected or pulled up to VCC.
26	TEST	Input	Puts the device into IC test mode. Must be tied to GND for normal operation, otherwise the device will appear to fail.
27	OSCI	Input	Input 12MHz Oscillator Cell. Optional – Can be left unconnected for normal operation. (See Note 1).
28	OSCO	Output	Output from 12MHZ Oscillator Cell. Optional – Can be left unconnected for normal operation if internal Oscillator is used. (See Note 1).

Table 3.7 Miscellaneous Signal Group

Pin No.	Name	Type	Description
30	TXD	Output	Transmit Asynchronous Data Output.
31	DTR#	Output	Data Terminal Ready Control Output / Handshake Signal.
32	RTS#	Output	Request to Send Control Output / Handshake Signal.
2	RXD	Input	Receiving Asynchronous Data Input.
3	RI#	Input	Ring Indicator Control Input. When remote wake up is enabled in the internal EEPROM taking RI# low (20ms active low pulse) can be used to resume the PC USB host controller from suspend.
6	DSR#	Input	Data Set Ready Control Input / Handshake Signal.
7	DCD#	Input	Data Carrier Detect Control Input.
8	CTS#	Input	Clear To Send Control Input / Handshake Signal.
9	CBUS4	I/O	Configurable CBUS output only Pin. Function of this pin is configured in the device internal EEPROM. Factory default configuration is SLEEP#. See CBUS Signal Options, Table 3.9.
10	CBUS2	I/O	Configurable CBUS I/O Pin. Function of this pin is configured in the device internal EEPROM. Factory default configuration is TXDEN. See CBUS Signal Options, Table 3.9.
11	CBUS3	I/O	Configurable CBUS I/O Pin. Function of this pin is configured in the device internal EEPROM. Factory default configuration is PWREN#. See CBUS Signal Options, Table 3.9. PWREN# should be used with a 10kΩ resistor pull up.
21	CBUS1	I/O	Configurable CBUS I/O Pin. Function of this pin is configured in the device internal EEPROM. Factory default configuration is RXLED#. See CBUS Signal Options, Table 3.9.
22	CBUS0	I/O	Configurable CBUS I/O Pin. Function of this pin is configured in the device internal EEPROM. Factory default configuration is TXLED#. See CBUS Signal Options, Table 3.9.

Table 3.8 UART Interface and CBUS Group (see note 1)
Notes:

- For details on how to use an external crystal, ceramic resonator, or oscillator with the FT232RN, please refer to Section 7.6.
- When used in Input Mode, the input pins are pulled to VCCIO via internal 200kΩ resistors. These pins can be programmed to gently pull low during USB suspend (PWREN# = "1") by setting an option in the internal EEPROM.

3.5 CBUS Signal Options

The following options can be configured on the CBUS I/O pins. CBUS signal options are common to both package versions of the FT232RN. These options can be configured in the internal EEPROM using the software utility [FT_PROG](#), which can be downloaded from the FTDI Utilities (www.ftdichip.com). The default configuration is described in Section 8.

CBUS Signal Option	Available On CBUS Pin	Description
TXDEN	CBUS0, CBUS1, CBUS2, CBUS3, CBUS4	Enable transmit data for RS485
PWREN#	CBUS0, CBUS1, CBUS2, CBUS3, CBUS4	Output is low after the device has been configured by USB, then high during USB suspending mode. This output can be used to control power to external logic P-Channel logic level MOSFET switch. Enable the interface pull-down option when using the PWREN# in this way. *
TXLED#	CBUS0, CBUS1, CBUS2, CBUS3, CBUS4	Transmit data LED drive: Data from USB Host to FT232RN. Pulses low when transmitting data via USB. See Section 7.5 for more details.
RXLED#	CBUS0, CBUS1, CBUS2, CBUS3, CBUS4	Receive data LED drive: Data from FT232RN to USB Host. Pulses low when receiving data via USB. See Section 7.5 for more details.
TX&RXLED#	CBUS0, CBUS1, CBUS2, CBUS3, CBUS4	LED drive – pulses low when transmitting or receiving data via USB. See Section 7.5 for more details.
SLEEP#	CBUS0, CBUS1, CBUS2, CBUS3, CBUS4	Goes low during USB suspend mode. Typically used to power down an external TTL to RS232 level converter IC in USB to RS232 converter designs.
CLK48	CBUS0, CBUS1, CBUS2, CBUS3, CBUS4	48MHz $\pm 0.7\%$ Clock output. **
CLK24	CBUS0, CBUS1, CBUS2, CBUS3, CBUS4	24 MHz Clock output. **
CLK12	CBUS0, CBUS1, CBUS2, CBUS3, CBUS4	12 MHz Clock output. **
CLK6	CBUS0, CBUS1, CBUS2, CBUS3, CBUS4	6 MHz $\pm 0.7\%$ Clock output. **
CBitBangI/O	CBUS0, CBUS1, CBUS2, CBUS3	CBUS bit bang mode option. Allows up to 4 of the CBUS pins to be used as general purpose I/O. Configured individually for CBUS0, CBUS1, CBUS2 and CBUS3 in the internal EEPROM. A separate application note, AN232R-01, available from FTDI website (www.ftdichip.com) describes in more detail how to use CBUS bit bang mode.
BitBangWRn	CBUS0, CBUS1	Synchronous and asynchronous bit bang mode WR# strobe output.
BitBangRDn	CBUS0, CBUS1, CBUS2, CBUS3	Synchronous and asynchronous bit bang mode RD# strobe output.

Table 3.9 CBUS Configuration Control

* PWREN# must be used with a 10k Ω resistor pull up.

**When in USB suspend mode the outputs clocks are also suspended.

4 Function Description

The FT232RN is a USB to serial UART interface device which simplifies USB to serial designs and reduces external component count by fully integrating an external EEPROM, USB termination resistors and an integrated clock circuit which requires no external crystal, into the device. It has been designed to operate efficiently with a USB host controller by using as little as possible of the total USB bandwidth available.

4.1 Key Features

Functional Integration. Fully integrated EEPROM, USB termination resistors, clock generation, AVCC filtering, POR and LDO regulator.

Configurable CBUS I/O Pin Options. The fully integrated EEPROM allows configuration of the Control Bus (CBUS) functionality, signal inversion and drive strength selection. There are 5 configurable CBUS I/O pins. These configurable options are -

1. **TXDEN** - transmit enable for RS485 designs.
2. **PWREN#** - Power control for high power, bus powered designs.
3. **TXLED#** - for pulsing an LED upon transmission of data.
4. **RXLED#** - for pulsing an LED upon receiving data.
5. **TX&RXLED#** - which will pulse an LED upon transmission OR reception of data.
6. **SLEEP#** - indicates that the device going into USB suspend mode.
7. **CLK48 / CLK24 / CLK12 / CLK6** - 48MHz, 24MHz, 12MHz, and 6MHz clock output signal options.
8. **BitBangWRn / BitBangRDn** - Synchronous and asynchronous bit bang mode WR# / RD# strobe outputs

The CBUS pins can also be individually configured as GPIO pins, similar to asynchronous bit bang mode. It is possible to use this mode while the UART interface is being used, thus providing up to 4 general purpose I/O pins which are available during normal operation. An application note, AN232R-01, available from FTDI website (www.ftdichip.com) describes this feature.

The CBUS lines can be configured with any one of these output options by setting bits in the internal EEPROM. The device is supplied with the most commonly used pin definitions pre-programmed - see Section 8 for details.

Asynchronous Bit Bang Mode with RD# and WR# Strobes. The FT232RN supports FTDI's previous chip generation bit-bang mode. In bit-bang mode, the eight UART lines can be switched from the regular interface mode to an 8-bit general purpose I/O port. Data packets can be sent to the device, and they will be sequentially sent to the interface at a rate controlled by an internal timer (equivalent to the baud rate pre-scaler). With the FT232RN device this mode has been enhanced by outputting the internal RD# and WR# strobes signals which can be used to allow external logic to be clocked by accesses to the bit-bang I/O bus. This option will be described more fully in a separate application note AN232R-01 available from FTDI website (www.ftdichip.com)[http://](http://www.ftdichip.com).

Synchronous Bit Bang Mode. The FT232RN supports synchronous bit bang mode. This mode differs from asynchronous bit bang mode in that the interface pins are only read when the device is written to. This makes it easier for the controlling program to measure the response to an output stimulus as the data returned is synchronous to the output data. An application note, AN232R-01, available from FTDI website (www.ftdichip.com) describes this feature.

FTDICHIP-ID™. The FT232RN also includes the new FTDICHIP-ID™ security dongle feature. This FTDICHIP-ID™ feature allows a unique number to be burnt into each device during manufacture. This number cannot be reprogrammed. This number is only readable over USB and forms a basis of a security dongle which can be used to protect any customer application software being copied. This allows the possibility of using the FT232RN in a dongle for software licensing. Further to this, a renewable license scheme can be implemented based on the FTDICHIP-ID™ number when encrypted with other information. This encrypted number can be stored in the user area of the FT232RN internal EEPROM, and can be decrypted, then compared with the protected FTDICHIP-ID™ to verify that a license is valid. Web based applications can be used to maintain product licensing this way. An application note, AN232R-02, available from FTDI website (www.ftdichip.com) describes this feature.

The FT232RN is capable of operating at a voltage supply between +3.3V and +5V with a nominal operational mode current of 15mA and a nominal USB suspend mode current of 70 μ A. This allows greater margin for peripheral designs to meet the USB suspend mode current limit of 2.5mA. An integrated level converter within the UART interface allows the FT232RN to interface to UART logic running at +1.8V, +2.8V, +3.3V or +5V.

4.2 Functional Block Descriptions

The following paragraphs detail each function within the FT232RN. Please refer to the block diagram shown in **Figure 2.1**.

Internal EEPROM. The internal EEPROM in the FT232RN is used to store USB Vendor ID (VID), Product ID (PID), device serial number, product description string and various other USB configuration descriptors. The internal EEPROM is also used to configure the CBUS pin functions. The FT232RN is supplied with the internal EEPROM pre-programmed as described in Section 8. A user area of the internal EEPROM is available to system designers to allow storing additional data. The internal EEPROM descriptors can be programmed in circuit, over USB without any additional voltage requirement. It can be programmed using the FTDI utility software called [FT_PROG](#), which can be downloaded from FTDI Utilities on the FTDI website (www.ftdichip.com).

+3.3V LDO Regulator. The +3.3V LDO regulator generates the +3.3V reference voltage for driving the USB transceiver cell output buffers. It requires an external decoupling capacitor to be attached to the 3V3OUT regulator output pin. It also provides +3.3V power to the 1.5k Ω internal pull up resistor on USBDP. The main function of the LDO is to power the USB Transceiver and the Reset Generator Cells rather than to power external logic. However, it can be used to supply external circuitry requiring a +3.3V nominal supply with a maximum current of 50mA.

USB Transceiver. The USB Transceiver Cell provides the USB 1.1 / USB 2.0 full-speed physical interface to the USB cable. The output drivers provide +3.3V level slew rate control signalling, whilst a differential input receiver and two single ended input receivers provide USB data in, Single-Ended-0 (SE0) and USB reset detection conditions, respectively. This function also incorporates the internal USB series termination resistors on the USB data lines and a 1.5k Ω pull up resistor on USBDP.

USB DPLL. The USB DPLL cell locks on to the incoming NRZI USB data and generates recovered clock and data signals for the Serial Interface Engine (SIE) block.

Internal 12MHz Oscillator - The Internal 12MHz Oscillator cell generates a 12MHz reference clock. This provides an input to the x4 Clock Multiplier function. The 12MHz Oscillator is also used as the reference clock for the SIE, USB Protocol Engine and UART FIFO controller blocks.

Clock Multiplier / Divider. The Clock Multiplier / Divider takes the 12MHz input from the Internal Oscillator function and generates the 48MHz, 24MHz, 12MHz and 6MHz reference clock signals. The 48MHz clock reference is used by the USB DPLL and the Baud Rate Generator blocks.

Serial Interface Engine (SIE). The Serial Interface Engine (SIE) block performs the parallel to serial and serial to parallel conversion of the USB data. In accordance with the USB 2.0 specification, it performs bit stuffing/un-stuffing and CRC5/CRC16 generation. It also checks the CRC on the USB data stream.

USB Protocol Engine. The USB Protocol Engine manages the data stream from the device USB control endpoint. It manages the low-level USB protocol requests generated by the USB host controller and the commands for controlling the functional parameters of the UART in accordance with the USB 2.0 specification chapter 9.

FIFO RX Buffer (128 bytes). Data sent from the USB host controller to the UART via the USB data OUT endpoint is stored in the FIFO RX (receive) buffer. Data is removed from the buffer to the UART transmit register under control of the UART FIFO controller. (Rx relative to the USB interface).

FIFO TX Buffer (256 bytes). Data from the UART receive register is stored in the TX buffer. The USB host controller removes data from the FIFO TX Buffer by sending a USB request for data from the device data IN endpoint. (Tx relative to the USB interface).

UART FIFO Controller. The UART FIFO controller manages the transfer of data between the FIFO RX and TX buffers and the UART transmit and receive registers.

UART Controller with Programmable Signal Inversion and High Drive. Together with the UART FIFO Controller the UART Controller manages the transfer of data between the FIFO RX and FIFO TX buffers and the UART transmit and receive registers. It performs asynchronous 7 or 8 bit parallel to serial and serial to parallel conversion of the data on the RS232 (or RS422 or RS485) interface.

Control signals supported by UART mode include RTS, CTS, DSR, DTR, DCD and RI. The UART Controller also provides a transmitter enable control signal pin option (TXDEN) to assist with interfacing to RS485 transceivers. RTS/CTS, DSR/DTR and XON / XOFF handshaking options are also supported. Handshaking is managed in hardware to ensure fast response times. The UART interface also supports the RS232 BREAK setting and detection conditions.

Additionally, the UART signals can each be individually inverted and have a configurable high drive strength capability. Both these features are configurable in the EEPROM.

Baud Rate Generator - The Baud Rate Generator provides a 16x clock input to the UART Controller from the 48MHz reference clock. It consists of a 14-bit pre-scaler and 3 register bits which provide fine tuning of the baud rate (used to divide by a number plus a fraction or "sub-integer"). This determines the baud rate of the UART, which is programmable from 183 baud to 3 Mbaud.

The FT232RN supports all standard baud rates and non-standard baud rates from 183 Baud up to 3 Mbaud. Achievable non-standard baud rates are calculated as follows -

$$\text{Baud Rate} = 3000000 / (n + x)$$

Where 'n' can be any integer between 2 and 16,384 ($= 2^{14}$) and 'x' can be a sub-integer of the value 0, 0.125, 0.25, 0.375, 0.5, 0.625, 0.75, or 0.875. When $n = 1$, $x = 0$, i.e., baud rate divisors with values between 1 and 2 are not possible.

This gives achievable baud rates in the range 183.1 baud to 3,000,000 baud. When a non-standard baud rate is required simply pass the required baud rate value to the driver as normal, and the FTDI driver will calculate the required divisor, and set the baud rate. See FTDI application note [AN_120](#) on the FTDI website (www.ftdichip.com) for more details.

RESET Generator - The integrated Reset Generator Cell provides a reliable power-on reset to the device internal circuitry at power up. The RESET# input pin allows an external device to reset the FT232RN. RESET# can be tied to VCC or left unconnected if not being used.

5 Devices Characteristics and Ratings

5.1 Absolute Maximum Ratings

The absolute maximum ratings for the FT232RN devices are as follows. These are in accordance with the Absolute Maximum Rating System (IEC 60134). Exceeding these may cause permanent damage to the device.

Parameter	Value	Units
Storage Temperature	-65 to 150	°C
Floor Life (Out of Bag) At Factory Ambient (30°C / 60% Relative Humidity)	168 (IPC/JEDEC J-STD-033A MSL Level 3 Compliant) *	Hours
Ambient Temperature (Power Applied)	-40 to 85	°C
VCC Supply Voltage	-0.5 to +6.00	V
DC Input Voltage – USBDP and USBDM	-0.5 to +3.8	V
DC Input Voltage – High Impedance Bidirectional	-0.5 to + (VCC +0.5)	V
DC Input Voltage – All Other Inputs	-0.5 to + (VCC +0.5)	V
DC Output Current – Outputs	24	mA
DC Output Current – Low Impedance Bidirectional	24	mA
Power Dissipation (VCC = 5.25V)	500	mW

Table 5.1 Absolute Maximum Ratings

* If devices are stored out of the packaging beyond this time limit the devices should be baked before use. The devices should be ramped up to a temperature of +125°C and baked for up to 17 hours.

5.2 DC Characteristics

DC Characteristics (Ambient Temperature = -40°C to +85°C)

Parameter	Description	Minimum	Typical	Maximum	Units	Conditions
VCC1	VCC Operating Supply Voltage	3.3	---	5.25	V	
VCC2	VCCIO Operating Supply Voltage	1.8	---	5.25	V	
Icc1	Operating Supply Current	---	15	---	mA	Normal Operation
Icc2	Operating Supply Current	50	70	100	µA	USB Suspend
3V3	3.3v regulator output	3.0	3.3	3.6	V	

Table 5.2 Operating Voltage and Current

Parameter	Description	Minimum	Typical	Maximum	Units	Conditions
Voh	Output Voltage High	3.2	4.1	4.9	V	I source = 2mA
Vol	Output Voltage Low	0.3	0.4	0.6	V	I sink = 2mA
Vin	Input Switching Threshold	1.0	1.2	1.5	V	**
VHys	Input Switching Hysteresis	20	25	30	mV	**

Table 5.3 UART and CBUS I/O Pin Characteristics (VCCIO = +5.0V, Standard Drive Level)

Parameter	Description	Minimum	Typical	Maximum	Units	Conditions
Voh	Output Voltage High	2.2	2.7	3.2	V	I source = 1mA
Vol	Output Voltage Low	0.3	0.4	0.5	V	I sink = 2mA
Vin	Input Switching Threshold	1.0	1.2	1.5	V	**
VHys	Input Switching Hysteresis	20	25	30	mV	**

Table 5.4 UART and CBUS I/O Pin Characteristics (VCCIO = +3.3V, Standard Drive Level)

Parameter	Description	Minimum	Typical	Maximum	Units	Conditions
Voh	Output Voltage High	2.1	2.6	2.8	V	I source = 1mA
Vol	Output Voltage Low	0.3	0.4	0.5	V	I sink = 2mA
Vin	Input Switching Threshold	1.0	1.2	1.5	V	**
VHys	Input Switching Hysteresis	20	25	30	mV	**

Table 5.5 UART and CBUS I/O Pin Characteristics (VCCIO = +2.8V, Standard Drive Level)

Parameter	Description	Minimum	Typical	Maximum	Units	Conditions
Voh	Output Voltage High	1.32	1.62	1.8	V	I source = 0.2mA
Vol	Output Voltage Low	0.06	0.1	0.18	V	I sink = 0.5mA
Vin	Input Switching Threshold	1.0	1.2	1.5	V	**
VHys	Input Switching Hysteresis	20	25	30	mV	**

Table 5.6 UART and CBUS I/O Pin Characteristics (VCCIO = +1.8V, Standard Drive Level)

Parameter	Description	Minimum	Typical	Maximum	Units	Conditions
Voh	Output Voltage High	3.2	4.1	4.9	V	I source = 6mA
Vol	Output Voltage Low	0.3	0.4	0.6	V	I sink = 6mA
Vin	Input Switching Threshold	1.0	1.2	1.5	V	**
VHys	Input Switching Hysteresis	20	25	30	mV	**

Table 5.7 UART and CBUS I/O Pin Characteristics (VCCIO = +5.0V, High Drive Level)

Parameter	Description	Minimum	Typical	Maximum	Units	Conditions
Voh	Output Voltage High	2.2	2.8	3.2	V	I source = 3mA
Vol	Output Voltage Low	0.3	0.4	0.6	V	I sink = 8mA
Vin	Input Switching Threshold	1.0	1.2	1.5	V	**
VHys	Input Switching Hysteresis	20	25	30	mV	**

Table 5.8 UART and CBUS I/O Pin Characteristics (VCCIO = +3.3V, High Drive Level)

Parameter	Description	Minimum	Typical	Maximum	Units	Conditions
Voh	Output Voltage High	2.1	2.6	2.8	V	I source = 3mA
Vol	Output Voltage Low	0.3	0.4	0.6	V	I sink = 8mA
Vin	Input Switching Threshold	1.0	1.2	1.5	V	**
VHys	Input Switching Hysteresis	20	25	30	mV	**

Table 5.9 UART and CBUS I/O Pin Characteristics (VCCIO = +2.8V, High Drive Level)

Parameter	Description	Minimum	Typical	Maximum	Units	Conditions
Voh	Output Voltage High	1.35	1.67	1.8	V	I source = 0.4mA
Vol	Output Voltage Low	0.12	0.18	0.35	V	I sink = 3mA
Vin	Input Switching Threshold	1.0	1.2	1.5	V	**
VHys	Input Switching Hysteresis	20	25	30	mV	**

Table 5.10 UART and CBUS I/O Pin Characteristics (VCCIO = +1.8V, High Drive Level)

** Only input pins have an internal 200K Ω pull-up resistor to VCCIO

Parameter	Description	Minimum	Typical	Maximum	Units	Conditions
Vin	Input Switching Threshold	1.3	1.6	1.9	V	
VHys	Input Switching Hysteresis	50	55	60	mV	

Table 5.11 RESET# and TEST Pin Characteristics

Parameter	Description	Minimum	Typical	Maximum	Units	Conditions
UVoh	I/O Pins Static Output (High)	2.8		3.6	V	RI = 1.5k Ω to 3V3OUT (D+) RI = 15k Ω to GND (D-)
UVol	I/O Pins Static Output (Low)	0		0.3	V	RI = 1.5k Ω to 3V3OUT (D+) RI = 15k Ω to GND (D-)
UVse	Single Ended Rx Threshold	0.8		2.0	V	
UCom	Differential Common Mode	0.8		2.5	V	
UVDif	Differential Input Sensitivity	0.2			V	
UDrvZ	Driver Output Impedance	26	29	44	Ohms	

Table 5.12 USB I/O Pin (USB DP, USB DM) Characteristics

5.3 EEPROM Reliability Characteristics

The internal 1024 Bit EEPROM has the following reliability characteristics:

Parameter	Value	Units
Data Retention	10	Years
Write	10,000	Cycles
Read	Unlimited	Cycles

Table 5.13 EEPROM Characteristics

5.4 Internal Clock Characteristics

The internal Clock Oscillator has the following characteristics:

Parameter	Value			Unit
	Minimum	Typical	Maximum	
Frequency of Operation (see Note 1)	11.98	12.00	12.02	MHz
Clock Period	83.19	83.33	83.47	ns
Duty Cycle	45	50	55	%

Table 5.14 Internal Clock Characteristics

Note1: Equivalent to +/-1667ppm

Parameter	Description	Minimum	Typical	Maximum	Units	Conditions
Voh	Output Voltage High		1.57		V	I source = 0.2mA
Vol	Output Voltage Low		0.25		V	I sink = 0.2mA
Vin	Input Switching Threshold		0.8		V	

Table 5.15 OSCI, OSCO Pin Characteristics – see Note 1

Note: When supplied, the FT232RN is configured to use its internal clock oscillator. These characteristics only apply when an external oscillator or crystal is used.

5.5 Thermal Characteristics

The FT232RNL package has the following thermal characteristics:

Parameter	Value	Units	Remark
Theta JA (θ_{JA})	81.36	°C/W	Estimated value for reference only
Theta JC (θ_{JC})	49.58	°C/W	Estimated value for reference only

Table 5.16 FT232RNL Thermal Characteristics

The FT232RNQ package has the following thermal characteristics:

Parameter	Value	Units	Remark
Theta JA (θ_{JA})	45.9	°C/W	Simulated value for reference only
Theta JC (θ_{JC})	17.7	°C/W	Simulated value for reference only

Table 5.17 FT232RNQ Thermal Characteristics

6 USB Power Configurations

The following sections illustrate possible USB power configurations for the FT232RN. The illustrations have omitted pin numbers for ease of understanding since the pins differ between the FT232RNL and FT232RNQ package options.

All USB power configurations illustrated apply to both package options for the FT232RN device. Please refer to Section 3 for the package option pin-out and signal descriptions.

6.1 USB Bus Powered Configuration

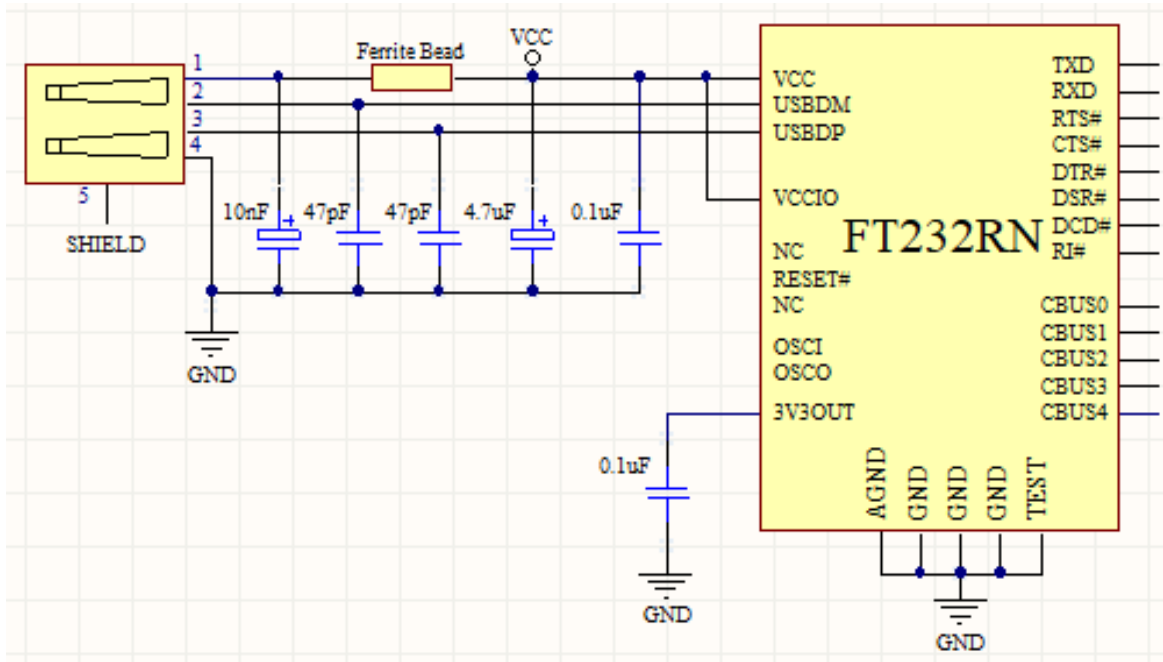

Figure 6.1 Bus Powered Configuration

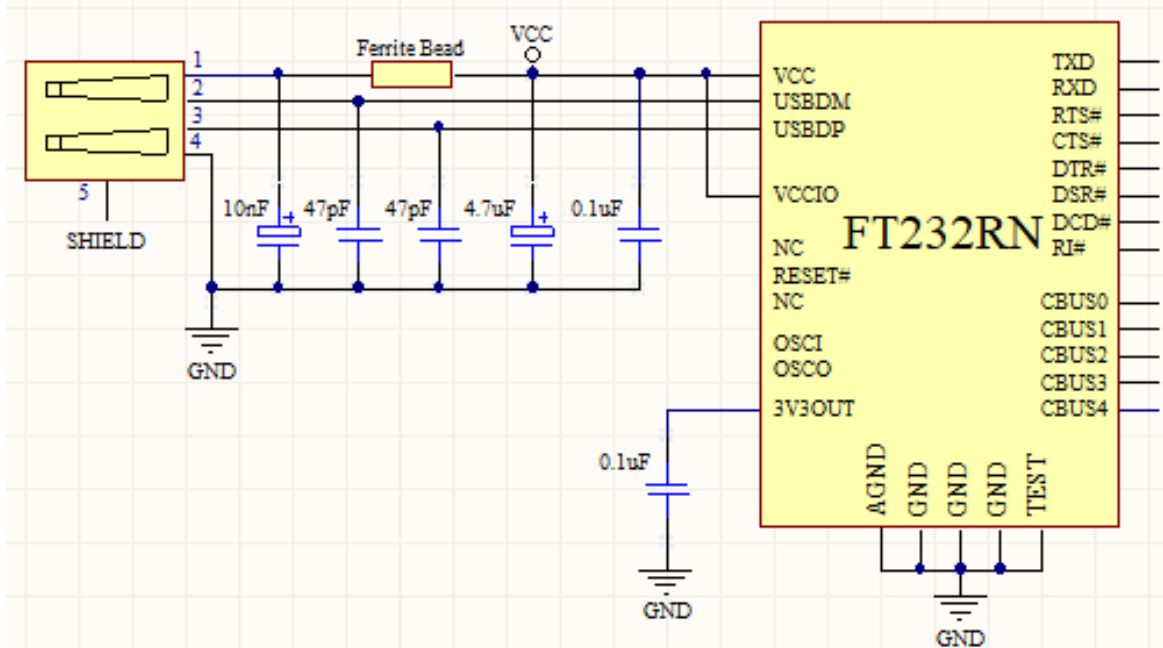

Figure 6.1 Illustrates the FT232RN in a typical USB bus powered design configuration. A USB bus powered device gets its power from the USB bus. Basic rules for USB bus power devices are as follows –

- i) On plug-in to USB, the device should draw no more current than 100mA.
- ii) In USB Suspend mode the device should draw no more than 2.5mA.
- iii) A bus powered high power USB device (one that draws more than 100mA) should use one of the CBUS pins configured as PWREN# and use it to keep the current below 100mA on plug-in and 2.5mA on USB suspend.
- iv) A device that consumes more than 100mA cannot be plugged into a USB bus powered hub.
- v) No device can draw more than 500mA from the USB bus.

The power descriptors in the internal EEPROM of the FT232RN should be programmed to match the current drawn by the device.

A ferrite bead is connected in series with the USB power supply to reduce EMI noise from the FT232RN and associated circuitry being radiated down the USB cable to the USB host. The value of the Ferrite Bead depends on the total current drawn by the application. A suitable range of Ferrite Beads is available from Laird (www.laird.com), for example Laird Part # MI0805K400R-10.

Note: If using PWREN# (available using the CBUS) the pin should be pulled to VCCIO using a 10kΩ resistor.

6.2 Self Powered Configuration

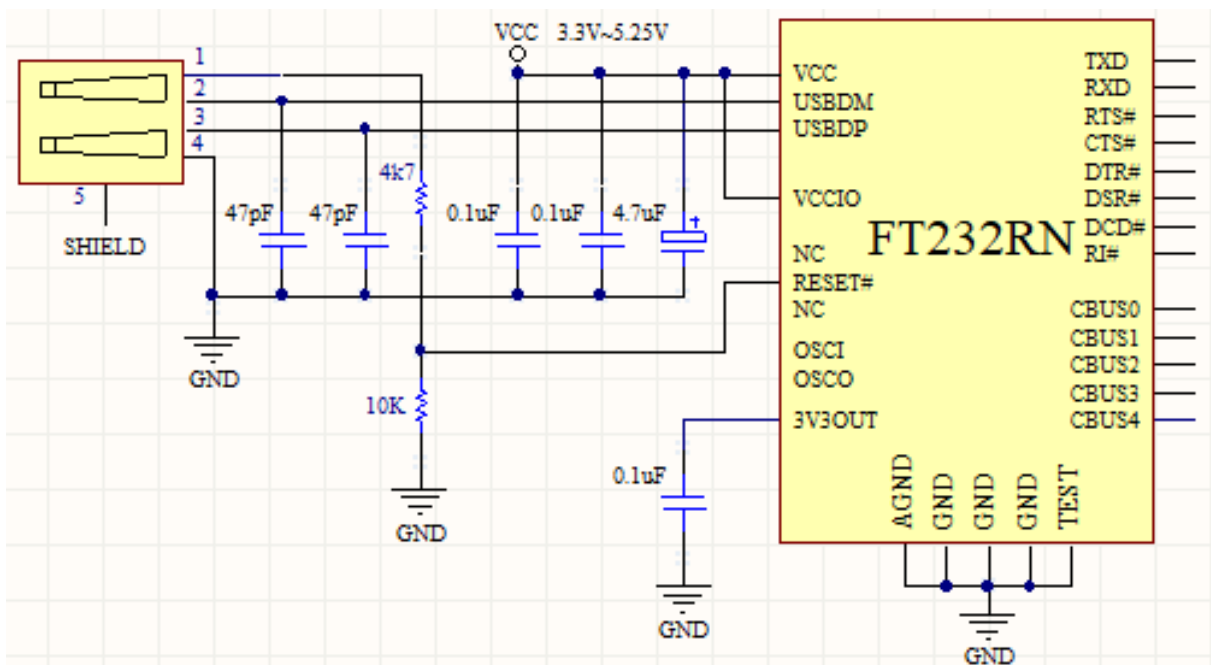

Figure 6.2 Self-Powered Configuration

Figure 6.2 illustrates the FT232RN in a typical USB self-powered configuration. A USB self-powered device gets its power from its own power supply, VCC, and does not draw current from the USB bus. The basic rules for USB self-powered devices are as follows –

- i) A self-powered device should not force current down the USB bus when the USB host or hub controller is powered down.
- ii) A self-powered device can use as much current as it needs during normal operation and USB suspend as it has its own power supply.
- iii) A self-powered device can be used with any USB host, a bus powered USB hub or a self-powered USB hub.

The power descriptor in the internal EEPROM of the FT232RN should be programmed to a value of zero (self-powered).

To comply with the first requirement above, the USB bus power (pin 1) is used to control the RESET# pin of the FT232RN device. When the USB host or hub is powered up an internal 1.5kΩ resistor on USBDP is

pulled up to +3.3V (generated using the 4K7 and 10k resistor network), thus identifying the device as a full speed device to the USB host or hub. When the USB host or hub is powered off, RESET# will be low and the FT232RN is held in reset. Since RESET# is low, the internal 1.5kΩ resistor is not pulled up to any power supply (hub or host is powered down), so no current flows down USBDP via the 1.5kΩ pull-up resistor. Failure to do this may cause some USB host or hub controllers to power up erratically.

Figure 6.2 illustrates a self-powered design which has a +3.3V to +5.25V supply.

Note:

1. When the FT232RN is in reset, the UART interface I/O pins are tri-stated. Input pins have internal 200kΩ pull-up resistors to VCCIO, so they will gently pull high unless driven by some external logic.
2. Any design which interfaces to +3.3 V or +1.8V would be having a +3.3V or +1.8V supply to VCCIO.

6.3 USB Bus Powered with Power Switching Configuration

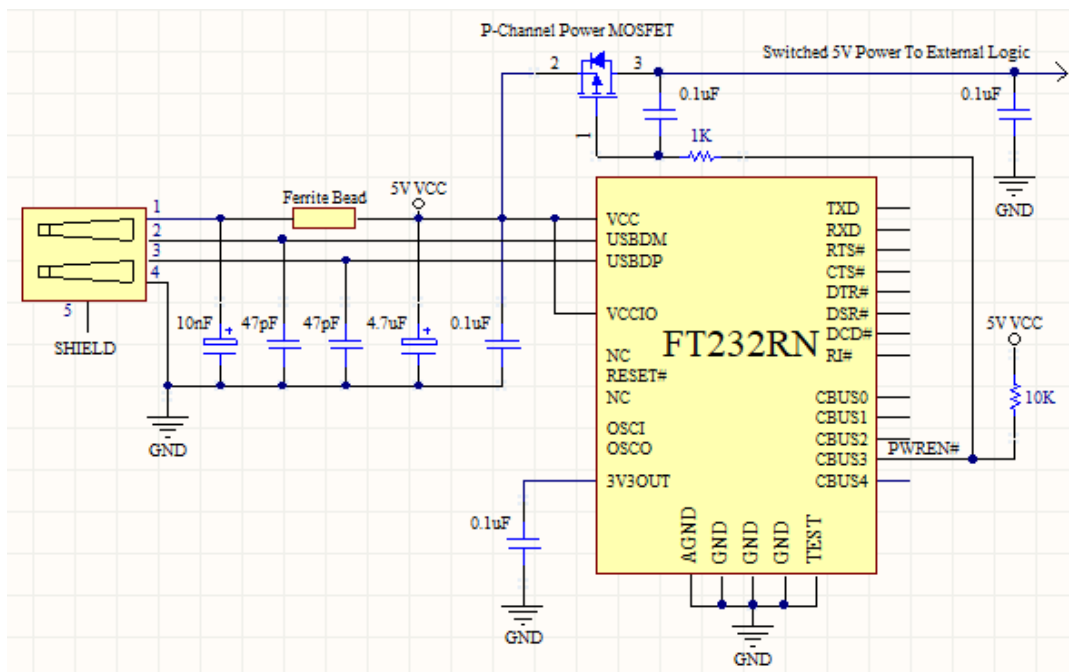

Figure 6.3 Bus Powered with Power Switching Configuration

A requirement of USB bus powered applications is when in USB suspend mode, the application draws a total current of less than 2.5mA. This requirement includes external logic. Some external logic could power itself down into a low current state by monitoring the PWREN# signal. For external logic that cannot power itself down in this way, the FT232RN provides a simple but effective method of turning off power during the USB suspend mode.

Figure 6.3 shows an example of using a discrete P-Channel MOSFET to control the power to external logic. A suitable device to do this is an International Rectifier (www.irf.com) IRLML6402, or equivalent. It is recommended that a "soft start" circuit consisting of a 1kΩ series resistor and a 0.1μF capacitor is used to limit the current surge when the MOSFET turns on. Without the soft start circuit, it is possible that the transient power surge, caused when the MOSFET switches on, will reset the FT232RN or the USB host/hub controller. The soft start circuit example shown in Figure 6.3 powers up with a slew rate of approximately 12.5V/ms. Thus, supply voltage to external logic transitions from GND to +5V in approximately 400 microseconds.

As an alternative to the MOSFET, a dedicated power switch IC with inbuilt "soft-start" can be used. A suitable power switch IC for such an application is the Micrel (www.micrel.com) MIC2025-2BM or equivalent.

With power switching controlled designs the following should be noted:

- i) The external logic to which the power is being switched should have its own reset circuitry to automatically reset the logic when power is re-applied when moving out of suspend mode.
- ii) Set the Pull-down on Suspend option in the internal FT232RN EEPROM.
- iii) One of the CBUS Pins should be configured as PWREN# in the internal FT232RN EEPROM and used to switch the power supply to the external circuitry. This should be pulled high through a 10 kΩ resistor.
- iv) For USB high-power bus powered applications (one that consumes greater than 100mA, and up to 500mA of current from the USB bus), the power consumption of the application must be set in the Max Power field in the internal FT232RN EEPROM. A high-power bus powered application uses the descriptor in the internal FT232RN EEPROM to inform the system of its power requirements.
- v) PWREN# gets its VCC from VCCIO. For designs using 3V3 logic, ensure VCCIO is not powered down using the external logic. In this case use the +3V3OUT.

6.4 USB Bus Powered with Selectable External Logic Supply

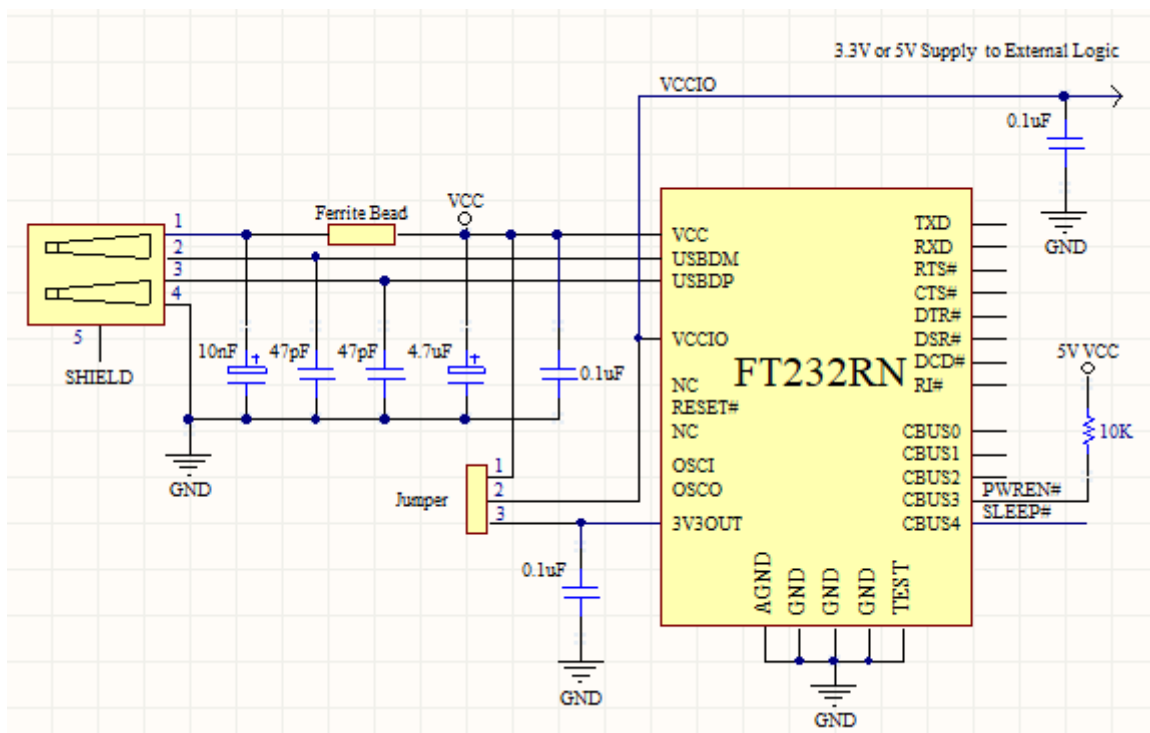

Figure 6.4 USB Bus Powered with +3.3V or +5V External Logic Power Supply

Figure 6.4 illustrates a USB bus power application with selectable external logic supply. The external logic can be selected between +3.3V and +5V using the jumper switch. This jumper is used to allow the FT232RN to be interfaced with a +3.3V or +5V logic devices. The VCCIO pin is either supplied with +5V from the USB bus (jumper pins 1 and 2 connected), or from the +3.3V output from the FT232RN 3V3OUT pin (jumper pins 2 and 3 connected). The supply to VCCIO is also used to supply external logic.

With bus powered applications, the following should be noted:

- i) To comply with the 2.5mA current supply limit during USB suspend mode, PWREN# or SLEEP# signals should be used to power down external logic in this mode. If this is not possible, use the configuration shown in Section 6.3.
- ii) The maximum current sourced from the USB bus during normal operation should not exceed 100mA, otherwise a bus powered design with power switching (Section 6.3) should be used.

Another possible configuration could use a discrete low dropout (LDO) regulator which is supplied by the 5V on the USB bus to supply between +1.8V and +2.8V to the VCCIO pin and to the external logic. In this case VCC would be supplied with the +5V from the USB bus and the VCCIO would be supplied from the

output of the LDO regulator. This results in the FT232RN I/O pins driving out at between +1.8V and +2.8V logic levels.

For a USB bus powered application, it is important to consider the following when selecting the regulator:

- i) The regulator must be capable of sustaining its output voltage with an input voltage of +4.35V. A Low Drop Out (LDO) regulator should be selected.
- ii) The quiescent current of the regulator must be low enough to meet the total current requirement of $\leq 2.5\text{mA}$ during USB suspend mode.

A suitable series of LDO regulators that meets these requirements is the MicroChip/Telecom (www.microchip.com) TC55 series of devices. These devices can supply up to 250mA current and have a quiescent current of under 1 μA .

7 Application Examples

The following sections illustrate possible applications of the FT232RN. The illustrations have omitted pin numbers for ease of understanding since the pins differ between the FT232RNL and FT232RNQ package options.

7.1 USB to RS232 Converter

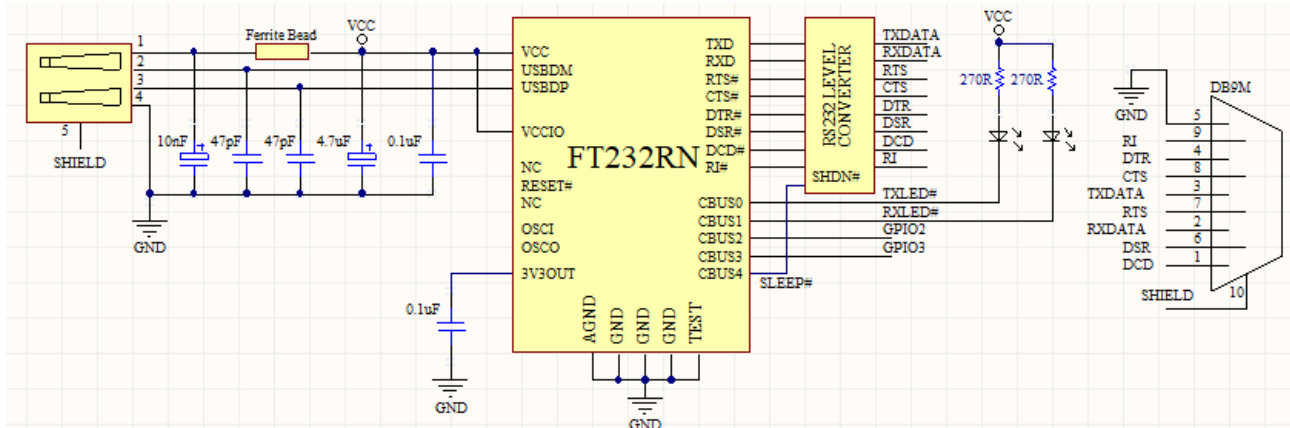

Figure 7.1 Application Example showing USB to RS232 Converter

An example of using the FT232RN as a USB to RS232 converter is illustrated in Figure 7.1. In this application, a TTL to RS232 Level Converter IC is used on the serial UART interface of the FT232RN to convert the TTL levels of the FT232RN to RS232 levels. This level shift can be done using the popular "213" series of TTL to RS232 level converters. These "213" devices typically have 4 transmitters and 5 receivers in a 28-LD SSOP package and feature an in-built voltage converter to convert the +5V (nominal) VCC to the +/- 9 volts required by RS232. A useful feature of these devices is the SHDN# pin which can be used to power down the device to a low quiescent current during USB suspend mode.

A suitable level shifting device is Sipex SP213EHCA which is capable of RS232 communication at up to 500k baud. If a lower baud rate is acceptable, then several pin compatible alternatives are available such as the Sipex SP213ECA, the Maxim MAX213CAI and the Analogue Devices ADM213E, which are all suitable for communication at up to 115.2k baud. If a higher baud rate is required, the Maxim MAX3245CAI device is capable of RS232 communication rates up to 1Mbaud. Note that the MAX3245 is not pin compatible with the 213 series devices and that the SHDN pin on the MAX device is active high and should be connected to the PWREN# pin instead of SLEEP# pin.

In example shown, the CBUS0 and CBUS1 have been configured as TXLED# and RXLED# and are being used to drive two LEDs.

7.2 USB to RS485 Converter

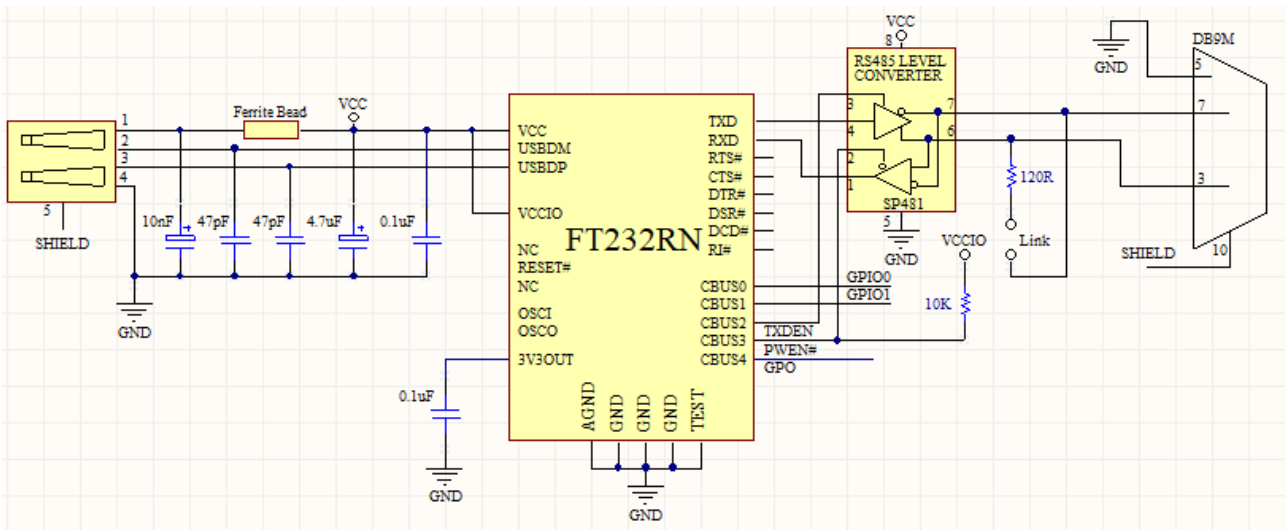

Figure 7.2 Application Example Showing USB to RS485 Converter

An example of using the FT232RN as a USB to RS485 converter is shown in Figure 7.2. In this application, a TTL to RS485 level converter IC is used on the serial UART interface of the FT232RN to convert the TTL levels of the FT232RN to RS485 levels.

This example uses Sipex SP481 device. Equivalent devices are available from Maxim and Analogue Devices. The SP481 is a RS485 device in a compact 8 pin SOP package. It has separate enables on both the transmitter and receiver. With RS485, the transmitter is only enabled when a character is being transmitted from the UART. The TXDEN signal CBUS pin option on the FT232RN is provided for exactly this purpose and so the transmitter enable is wired to CBUS2 which has been configured as TXDEN. Similarly, CBUS3 has been configured as PWREN#. This signal is used to control the SP481's receiver enable. The receiver enable is active low, so it is wired to the PWREN# pin to disable the receiver when in USB suspend mode. CBUS2 = TXDEN and CBUS3 = PWREN# are the default device configurations of the FT232RN pins.

RS485 is a multi-drop network; so many devices can communicate with each other over a two-wire cable interface. The RS485 cable requires to be terminated at each end of the cable. A link (which provides the 120Ω termination) allows the cable to be terminated if the SP481 is physically positioned at either end of the cable.

In this example the data transmitted by the FT232RN is also present on the receive path of the SP481. This is a common feature of RS485 and requires the application software to remove the transmitted data from the received data stream. With the FT232RN it is possible to do this entirely in hardware by modifying the example shown in Figure 7.2 by logically OR'ing the FT232RN TXDEN and the SP481 receiver output and connecting the output of the OR gate to the RXD of the FT232RN.

Note that the TXDEN is activated 1 bit period before the start bit. TXDEN is deactivated at the same time as the stop bit. This is not configurable.

7.4 USB to MCU UART Interface

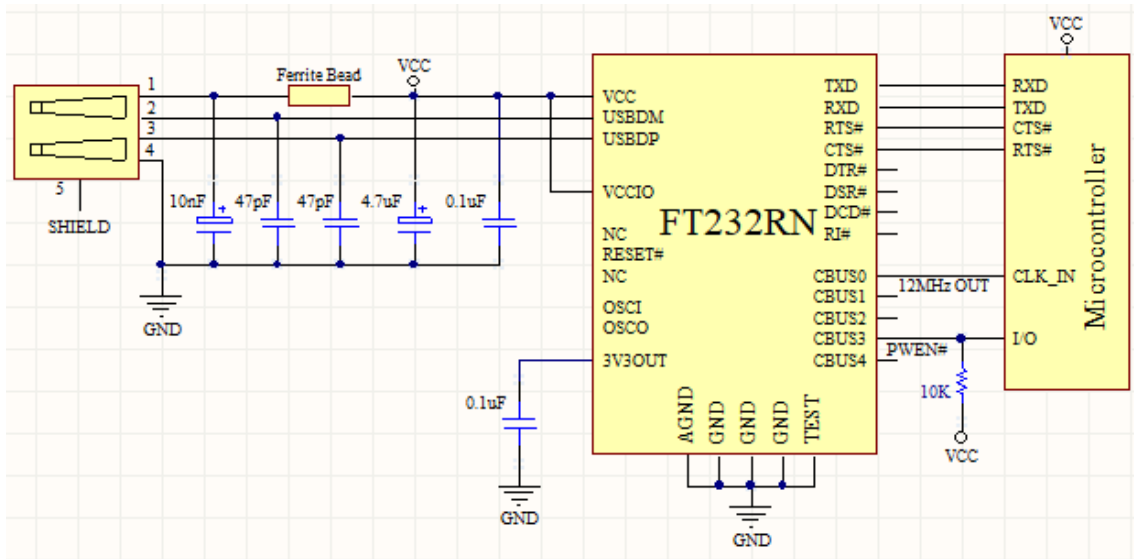

Figure 7.4 USB to MCU UART Interface

An example of using the FT232RN as a USB to Microcontroller (MCU) UART interface is shown in Figure 7.4. In this application the FT232RN uses TXD and RXD for transmission and reception of data, and RTS# / CTS# signals for hardware handshaking. In this example CBUS0 has been configured as a 12MHz output to clock the MCU (the clock will stop when in suspend mode).

Optionally, RI# could be connected to another I/O pin on the MCU and used to wake up the USB host controller from suspend mode. If the MCU is overseeing power management functions, then a CBUS pin can be configured as PWREN# and would also be connected to an I/O pin of the MCU.

7.5 LED Interface

Any of the CBUS I/O pins can be configured to drive an LED. The FT232RN has 3 configuration options for driving LEDs from CBUS. These are TXLED#, RXLED#, and TX&RXLED#. Refer to Section 3.5 for configuration options.

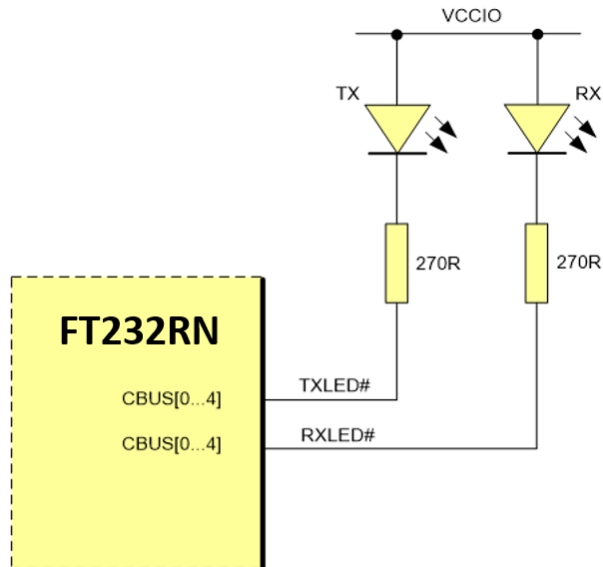

Figure 7.5 Dual LED Configuration

An example of using the FT232RN to drive LEDs is shown in Figure 7.5. In this application one of the CBUS pins is used to indicate transmission of data (TXLED#) and another is used to indicate receiving data (RXLED#). When data is being transmitted or received the respective pins will drive from tristate to low in order to provide indication on the LEDs of data transfer. A digital one-shot is used so that even a small percentage of data transfer is visible to the end user.

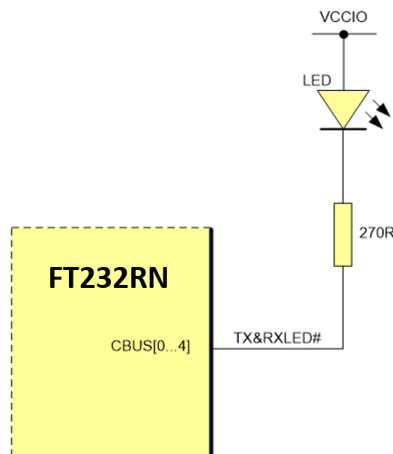

Figure 7.6 Single LED Configuration

7.6 Using the External Oscillator

The factory default configuration of FT232RN is to use internal oscillator which can be operated normally from VCC = 5.25V down-to 3.3V. Alternatively, the device may be configured to use external oscillator with the same VCC range. An external oscillator can be either crystal or clock source, but if application is using external clock source instead of external crystal or internal oscillator, then it requires to adjust the external clock source input level to be below 1.98V. Please refer to [TN_183](#).

8 Internal EEPROM Configuration

Following a power-on reset or a USB reset the FT232RN will scan its internal EEPROM and read the USB configuration descriptors stored there. The default factory programmed values of the internal EEPROM are shown in Table 8.1.

Parameter	Value	Notes
USB Vendor ID (VID)	0403h	FTDI default VID (hex)
USB Product ID (PID)	6001h	FTDI default PID (hex)
Serial Number Enabled?	Yes	
Serial Number	See Note	A unique serial number is generated and programmed into the EEPROM during device final test.
Pull down I/O Pins in USB Suspend	Disabled	Enabling this option will make the device pull down on the UART interface lines when in USB suspend mode (PWREN# is high).
Manufacturer Name	FTDI	
Product Description	FT232R USB UART	
Max Bus Power Current	90mA	
Power Source	Bus Powered	
Device Type	FT232R	
USB Version	0200	Returns USB 2.0 device description to the host. Note: The device is a USB 2.0 Full Speed device (12Mb/s) as opposed to a USB 2.0 High Speed device (480Mb/s).
Remote Wake Up	Enabled	Taking RI# low will wake up the USB host controller from suspend in approximately 20 ms.
High Current I/Os	Disabled	Enables the high drive level on the UART and CBUS I/O pins.
Load VCP Driver	Enabled	Makes the device load the VCP driver interface for the device.
CBUS0	TXLED#	Default configuration of CBUS0 – Transmit LED drive.
CBUS1	RXLED#	Default configuration of CBUS1 – Receive LED drive.
CBUS2	TXDEN	Default configuration of CBUS2 – Transmit data enable for RS485
CBUS3	PWREN#	Default configuration of CBUS3 – Power enable. Low after USB enumeration, high during USB suspend mode.
CBUS4	SLEEP#	Default configuration of CBUS4 – Low during USB suspend mode.
Invert TXD	Disabled	Signal on this pin becomes TXD# if enable.
Invert RXD	Disabled	Signal on this pin becomes RXD# if enable.
Invert RTS#	Disabled	Signal on this pin becomes RTS if enable.
Invert CTS#	Disabled	Signal on this pin becomes CTS if enable.
Invert DTR#	Disabled	Signal on this pin becomes DTR if enable.
Invert DSR#	Disabled	Signal on this pin becomes DSR if enable.
Invert DCD#	Disabled	Signal on this pin becomes DCD if enable.
Invert RI#	Disabled	Signal on this pin becomes RI if enable.

Table 8.1 Default Internal EEPROM Configuration

The internal EEPROM in FT232RN can be programmed over USB using the FTDI utility program [FT_PROG](#). FT_PROG can be downloaded from FTDI Utilities on the FTDI website (www.ftdichip.com). Version 2.8a or later is required for the FT232RN chip. Users who do not have their own USB Vendor ID but who would like to use a unique Product ID in their design can apply to FTDI for a free block of unique PIDs. Contact FTDI support for this service.

9 Package Parameters

The FT232RN is available in two different packages. The FT232RNL is the SSOP-28 option and the FT232RNQ is the QFN-32 package option.

9.1 SSOP-28 Package Dimension

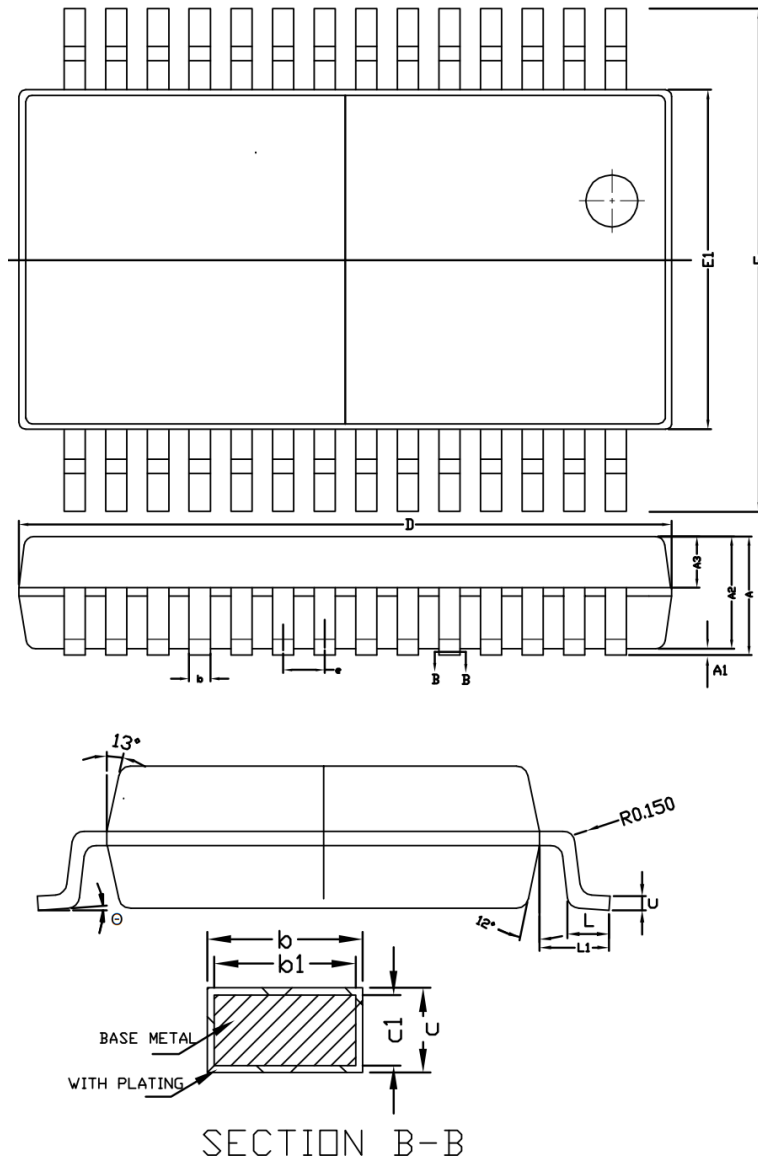

DIM SYMBOL	MIN.	NOM.	MAX.
A	-	-	2.00
A1	0.05	-	0.25
A2	1.65	1.75	1.85
A3	0.75	0.80	0.85
b	0.29	-	0.37
b1	0.28	0.30	0.33
c	0.15	-	0.20
c1	0.14	0.15	0.16
D	10.00	10.20	10.40
E	7.60	7.80	8.00
E1	5.10	5.30	5.50
e	0.65BSC		
L	0.55	0.75	0.95
L1	1.25BSC		
θ	0°	-	8°

NOTES:

- 1) LEAD FRAME : A194 (THICKNESS : 0.152MM)
- 2) LEAD FINISH : SOLDER PLATED
- 3) BOTH PACKAGE LENGTH AND WIDTH DO NOT INCLUDE FLASH.
- 4) FORMED LEAD SHALL BE PLANAR WITH RESPECT TO ONE ANOTHER WITHIN 0.10(0.004)
- 5) CONTROLLING DIMENSION : MM .
- 6) UNREMOVED FLASH BETWEEN LEADS & PACKAGE END FLASH SHALL NOT EXCEED 0.15MM FROM BOTTOM BODY PER SIDE.
- 7) EDP PACKAGE: EXPOSED PAD SIZE P1 & P2 ARE VARIATIONS DEPENDING ON DEVICE FUNCTION (DIE PADDLE SIZE).

Figure 9.1 SSOP-28 Package Dimensions

The FT232RNL is supplied in a RoHS compliant 28 pin SSOP package. The package is lead (Pb) free and uses a 'green' compound. The package is fully compliant with European Union directive 2002/95/EC.

This package is nominally 5.30mm x 10.20mm body (7.80mm x 10.20mm including pins). The pins are on a 0.65 mm pitch. The above mechanical drawing shows the SSOP-28 package.

All dimensions are in millimetres.

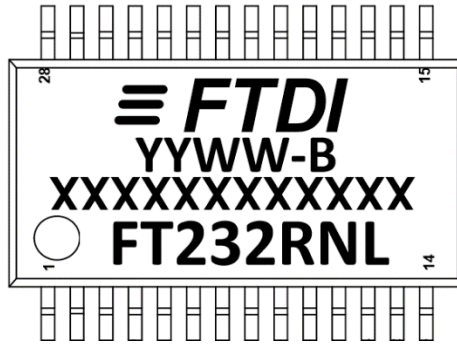

The date code format is **YYWW-B** where WW = 2-digit week number, YY = 2-digit year number, B = single letter corresponding to the revision of the device (e.g., A or B or C).

The code **XXXXXXXXXXXX** is the manufacturing LOT code. This only applies to devices manufactured after April 2009.

9.2 QFN-32 Package Dimensions

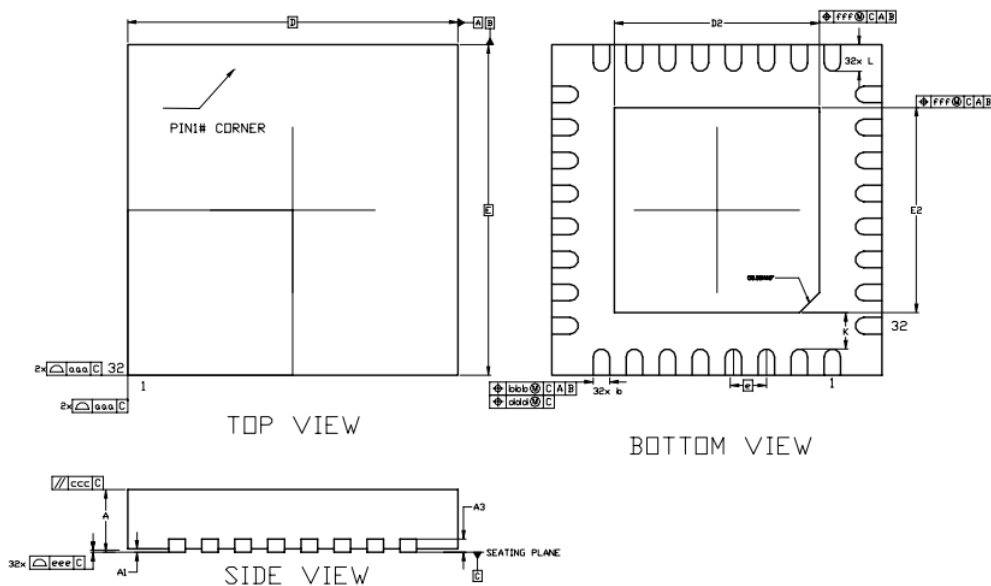

DIM SYMBOL	MIN.	NOM.	MAX.
A	0.80	0.85	0.90
A1	0	0.02	0.05
A3	-	0.20 REF	-
b	0.20	0.25	0.30
D	5.00BSC		
E	5.00BSC		
D2	3.00	3.10	3.20
E2	3.00	3.10	3.20
e	0.50BSC		
L	0.35	0.40	0.45
K	-	0.55	-
aaa	0.15		
bbb	0.10		
ccc	0.10		
ddd	0.05		
eee	0.08		
fff	0.10		

NOTES:

1. DIMENSIONING AND TOLERANCING CONFIRM TO ASME Y14.5M-1994
2. ALL DIMENSIONS ARE IN MILLIMETERS, ANGLES ARE IN DEGREE.
3. UNILATERAL COPLANARITY ZONE APPLIES TO THE EXPOSED HEAT SINK SLUG AS WELL AS THE TERMINALS.
4. DIMENSION b APPLIES TO METALLIZED TERMINAL AND IS MEASURED BETWEEN 0.150mm TO 0.30mm FROM THE TERMINAL TIP. DIMENSION b SHOULD NOT BE MEASURED IN RADIUS AREA.
5. ALL SPEC TAKE JEDEC MD-220 FOR REFERENCE.

Figure 9.2 QFN-32 Package Dimensions

The FT232RNQ is supplied in a RoHS compliant leadless QFN-32 package. The package is lead (Pb) free and uses a 'green' compound. The package is fully compliant with European Union directive 2002/95/EC.

This package is nominally 5.00mm x 5.00mm. The solder pads are on a 0.50mm pitch. The above mechanical drawing shows the QFN-32 package. All dimensions are in millimetres.

The centre pad on the base of the FT232RNQ is not internally connected, and can be left unconnected, or connected to ground (recommended).

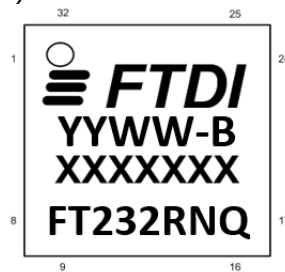

The date code format is **YYWW-B** where WW = 2-digit week number, YY = 2-digit year number, B = single letter corresponding to the revision of the device (e.g., A or B or C).

The code **XXXXXXX** is the manufacturing LOT code. This only applies to devices manufactured after April 2009.

9.3 Solder Reflow Profile

The FT232RN is supplied in Pb free 28 LD SSOP and QFN-32 packages. The recommended solder reflow profile for both package options is shown in Figure 9.3.

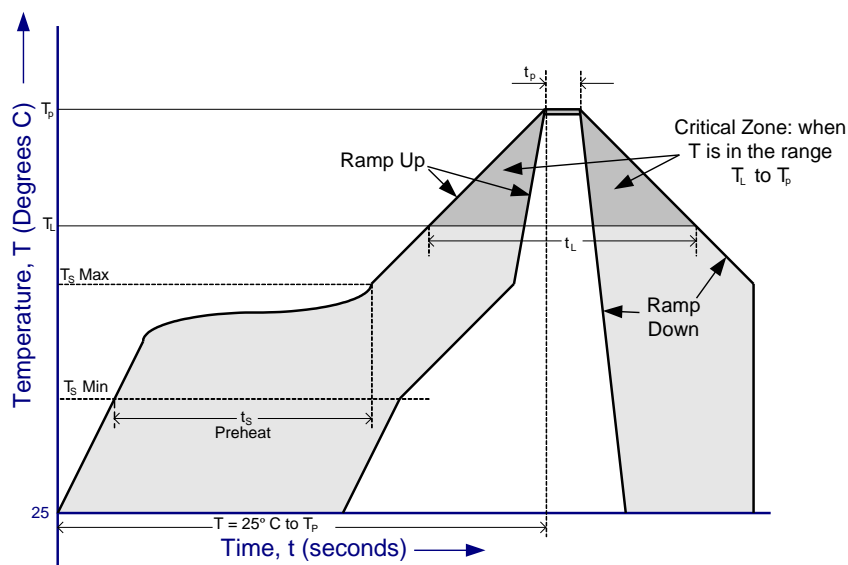

Figure 9.3 FT232RN Solder Reflow Profile

The recommended values for the solder reflow profile are detailed in Table 9.1. Values are shown for both a completely Pb free solder process (i.e., the FT232RN is used with Pb free solder), and for a non-Pb free solder process (i.e., the FT232RN is used with non-Pb free solder).

Profile Feature	Pb Free Solder Process	Non-Pb Free Solder Process
Average Ramp Up Rate (T_s to T_p)	3°C / second Max.	3°C / Second Max.
Preheat - Temperature Min (T_s Min.) - Temperature Max (T_s Max.) - Time (t_s Min to t_s Max)	150°C 200°C 60 to 120 seconds	100°C 150°C 60 to 120 seconds
Time Maintained Above Critical Temperature T_L : - Temperature (T_L) - Time (t_L)	217°C 60 to 150 seconds	183°C 60 to 150 seconds
Peak Temperature (T_p)	260°C	240°C
Time within 5°C of actual Peak Temperature (t_p)	20 to 40 seconds	20 to 40 seconds
Ramp Down Rate	6°C / second Max.	6°C / second Max.
Time for $T = 25^\circ\text{C}$ to Peak Temperature, T_p	8 minutes Max.	6 minutes Max.

Table 9.1 Reflow Profile Parameter Values

10 Alternative Parts

The following lists of parts are not all direct drop-in replacements but offer similar features as an alternative to the FT232RN. The [FT-X](#) series is the latest device family offering reduced power and pin count with additional features such as battery charge detection, while the Hi-Speed solution offers faster interfacing.

	FT232RN	FT234XD	FT230X	FT231X	FT232H
Description	Single channel USB to UART with full modem control lines	Single channel USB to Basic UART	Single channel USB to Basic UART	Single channel USB to UART with full modem control lines	Single channel USB to UART with full modem control lines
USB Speed	USB 2.0 full speed	USB 2.0 full speed	USB 2.0 full speed	USB 2.0 full speed	USB 2.0 hi-speed
UART Data Rates	3 MBaud	3 MBaud	3 MBaud	3 MBaud	12 MBaud
CBUS	5	1	4	4	10
MTP for storing descriptors	Internal	Internal	Internal	Internal	External
Package options	32 pin QFN 28 pin SSOP	12 pin DFN (3mm x 3mm)	16 pin QFN 16 pin SSOP	20 pin QFN 20 pin SSOP	48 pin QFN 48 pin LQFP
Datasheet	This document	FT234XD	FT230X	FT231X	FT232H

Table 10.1 FT232RN alternative solutions

11 Contact Information

Head Office – Glasgow, UK

Future Technology Devices International Limited
Unit 1, 2 Seaward Place
Centurion Business Park
Glasgow, G41 1HH
United Kingdom
Tel: +44 (0) 141 429 2777
Fax: +44 (0) 141 429 2758

E-mail (Sales) sales1@ftdichip.com
E-mail (Support) support1@ftdichip.com
E-mail (General Enquiries) admin1@ftdichip.com
Web Shop URL <http://www.ftdichip.com>

Branch Office – Taipei, Taiwan

Future Technology Devices International Limited
(Taiwan)
2F, No 516, Sec. 1 NeiHu Road
Taipei 114
Taiwan, R.O.C.
Tel: +886 (0) 2 8797 1330
Fax: +886 (0) 2 8751 9737

E-mail (Sales) tw.sales1@ftdichip.com
E-mail (Support) tw.support1@ftdichip.com
E-mail (General Enquiries) tw.admin1@ftdichip.com

Web Site

<http://www.ftdichip.com>

Distributor and Sales Representatives

Please visit the Sales Network page of the [FTDI Web site](#) for the contact details of our distributor(s) and sales representative(s) in your country.

System and equipment manufacturers and designers are responsible to ensure that their systems, and any Future Technology Devices International Ltd (FTDI) devices incorporated in their systems, meet all applicable safety, regulatory and system-level performance requirements. All application-related information in this document (including application descriptions, suggested FTDI devices and other materials) is provided for reference only. While FTDI has taken care to assure it is accurate, this information is subject to customer confirmation, and FTDI disclaims all liability for system designs and for any applications assistance provided by FTDI. Use of FTDI devices in life support and/or safety applications is entirely at the user's risk, and the user agrees to defend, indemnify, and hold harmless FTDI from any and all damages, claims, suits, or expense resulting from such use. This document is subject to change without notice. No freedom to use patents or other intellectual property rights is implied by the publication of this document. Neither the whole nor any part of the information contained in, or the product described in this document, may be adapted, or reproduced in any material or electronic form without the prior written consent of the copyright holder. Future Technology Devices International Ltd, Unit 1, 2 Seaward Place, Centurion Business Park, Glasgow G41 1HH, United Kingdom. Scotland Registered Company Number: SC136640

Branch Office – Tigard, Oregon, USA

Future Technology Devices International Limited (USA)
7130 SW Fir Loop
Tigard, OR 97223-8160
USA
Tel: +1 (503) 547 0988
Fax: +1 (503) 547 0987

E-Mail (Sales) us.sales@ftdichip.com
E-Mail (Support) us.support@ftdichip.com
E-Mail (General Enquiries) us.admin@ftdichip.com

Branch Office – Shanghai, China

Future Technology Devices International Limited
(China)
Room 1103, No. 666 West Huaihai Road,
Shanghai, 200052
China
Tel: +86 21 62351596
Fax: +86 21 62351595

E-Mail (Sales) cn.sales@ftdichip.com
E-Mail (Support) cn.support@ftdichip.com
E-Mail (General Enquiries) cn.admin1@ftdichip.com

Appendix A – References

Document References

[AN_232R-01 Bit Bang Mode Available for FT232R and FT245R](#)

[AN_107-Advanced Driver Options](#)

[AN232R-02 FTDIChip-ID for the FT232R and FT245R](#)

[AN_121- Accessing the EEPROM User Area of FTDI Devices](#)

[AN_120 Aliasing VCP Baud Rates](#)

[AN_100 – Using the FT232R/FT245R with an External Crystal or Oscillator](#)

[AN_126 – User Guide for FT232B/R Factory Test Utility](#)

[AN232B-05 Configuring FT232R, FT2232 and FT232B Baud Rates](#)

<http://www.ftdichip.com/Documents/InstallGuides.htm>

[FT_PROG](#)

Acronyms and Abbreviations

Terms	Description
EEPROM	Electrically Erasable Programmable Read-Only Memory
FPGA	Field Programmable Gate Array
LED	Light Emitting Diode
MCU	Micro Controller Unit
PLD	Programmable Logic Device
QFN	Quad Flat No-leads
RoHS	Restriction of Hazardous Substances Directive
SIE	Serial Interface Engine
UART	Universal Asynchronous Receiver/Transmitter
USB	Universal Serial Bus
VCP	Virtual Communication Port

Appendix B – List of Figures and Tables

List of Figures

Figure 2.1 FT232RN Block Diagram	4
Figure 3.1 SSOP Package Pin Out and Schematic Symbol.....	7
Figure 3.2 QFN-32 Package Pin Out and schematic symbol	9
Figure 6.1 Bus Powered Configuration	19
Figure 6.2 Self-Powered Configuration.....	20
Figure 6.3 Bus Powered with Power Switching Configuration	21
Figure 6.4 USB Bus Powered with +3.3V or +5V External Logic Power Supply	22
Figure 7.1 Application Example showing USB to RS232 Converter.....	24
Figure 7.2 Application Example Showing USB to RS485 Converter	25
Figure 7.3 USB to RS422 Converter Configuration.....	26
Figure 7.4 USB to MCU UART Interface	27
Figure 7.5 Dual LED Configuration	28
Figure 7.6 Single LED Configuration	28
Figure 9.1 SSOP-28 Package Dimensions	31
Figure 9.2 QFN-32 Package Dimensions.....	33
Figure 9.3 FT232RN Solder Reflow Profile	33

List of Tables

Table 3.1 USB Interface Group	7
Table 3.2 Power and Ground Group.....	7
Table 3.3 Miscellaneous Signal Group.....	8
Table 3.4 UART Interface and CUSB Group (see note 2)	8
Table 3.5 USB Interface Group	9
Table 3.6 Power and Ground Group.....	9
Table 3.7 Miscellaneous Signal Group.....	10
Table 3.8 UART Interface and CBUS Group (see note 1)	10
Table 3.9 CBUS Configuration Control	11
Table 5.1 Absolute Maximum Ratings	15
Table 5.2 Operating Voltage and Current	15
Table 5.3 UART and CBUS I/O Pin Characteristics (VCCIO = +5.0V, Standard Drive Level)	15
Table 5.4 UART and CBUS I/O Pin Characteristics (VCCIO = +3.3V, Standard Drive Level)	16
Table 5.5 UART and CBUS I/O Pin Characteristics (VCCIO = +2.8V, Standard Drive Level)	16
Table 5.6 UART and CBUS I/O Pin Characteristics (VCCIO = +1.8V, Standard Drive Level)	16
Table 5.7 UART and CBUS I/O Pin Characteristics (VCCIO = +5.0V, High Drive Level).....	16
Table 5.8 UART and CBUS I/O Pin Characteristics (VCCIO = +3.3V, High Drive Level).....	16
Table 5.9 UART and CBUS I/O Pin Characteristics (VCCIO = +2.8V, High Drive Level).....	16
Table 5.10 UART and CBUS I/O Pin Characteristics (VCCIO = +1.8V, High Drive Level)	17

Table 5.11 RESET# and TEST Pin Characteristics	17
Table 5.12 USB I/O Pin (USBDP, USBDM) Characteristics	17
Table 5.13 EEPROM Characteristics	17
Table 5.14 Internal Clock Characteristics	17
Table 5.15 OSCI, OSCO Pin Characteristics – see Note 1	18
Table 5.16 FT232RNL Thermal Characteristics	18
Table 5.17 FT232RNQ Thermal Characteristics	18
Table 8.1 Default Internal EEPROM Configuration	30
Table 9.1 Reflow Profile Parameter Values	34
Table 10.1 FT232RN alternative solutions	35



Appendix C – Revision History

Document Title: FT232RN USB UART IC Datasheet
Document Reference No.: FT_001521
Clearance No.: FTDI#571
Product Page: <https://ftdichip.com/product-category/products/ic/>
Document Feedback: [Send Feedback](#)







Revision	Changes	Date
Version 1.0	Initial Release	04-04-2022

Looking for pricing, stock, or lifecycle information?

Click below to explore more details on WIN SOURCE:

-  [View FT232RNQ-TRAY on WIN SOURCE](#)
-  [FTDI, Future Technology Devices International Ltd Information](#)

Optimize Your Supply Chain with WIN SOURCE Solutions

-  Global Sourcing Solution
-  Obsolete Management
-  Cost Control Management
-  Shortage Management
-  Alternative Solution
-  Excess Inventory Management