



**THE DATASHEET OF
AP3917CS7-13**



Description

The AP3917C is a universal AC voltage step-down power switcher, which is specially designed for home appliance and IoT applications with non-isolated buck solution or offline flyback solution.

The device integrates a 650V high-performance Power MOSFET. Coordinating with a single-winding inductor, it uses fewer external components and provides a low Bill of Material (BOM) cost solution.

The AP3917C can achieve excellent regulation and high-power efficiency. The peak current and switching frequency continuously reduce as the load decreases, so it can get excellent efficiency performance at light load and improve the overall system efficiency.

The AP3917C has multiple protection features to enhance system safety and reliability. It has over-temperature protection, under-voltage lock function, output short protection, overload protection, and open-loop protection.

The AP3917C is available in the SO-7 package.

Pin Assignments

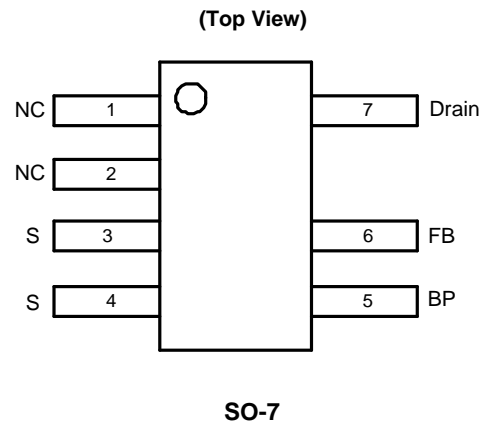

Features

- Universal 85V_{AC} to 300V_{AC} Input Range
- Internal MOSFET of 650V
- Maximal Peak Current: 420mA Typical
- Improved Constant Voltage: ±5%
- Maximum 270mA Rated Output Current
- No Load Power Consumption: < 30mW with External Bias
- Frequency Modulation to Suppress EMI
- Various Protections: OTP (Over Temperature Protection), OLP (Overload Protection), SCP (Short Circuit Protection)
- Fewer Components
- Low Audible Noise Solution
- SO-7 Package
- Moisture Sensitivity: MSL Level 3 per J-STD-020
- Terminals: Finish – Matte Tin Plated Leads, Solderable per M2003 JESD22-B102, Method 208
- Weight: 0.077 grams (Approximate)
- **Totally Lead-Free & Fully RoHS Compliant (Notes 1 & 2)**
- **Halogen- and Antimony-Free. “Green” Device (Note 3)**
- **For automotive applications requiring specific change control (i.e. parts qualified to AEC-Q100/101/200, PPAP capable, and manufactured in IATF 16949 certified facilities), please [contact us](mailto:contact@diodes.com) or your local Diodes representative. <https://www.diodes.com/quality/product-definitions/>**

- Notes:
1. No purposely added lead. Fully EU Directive 2002/95/EC (RoHS), 2011/65/EU (RoHS 2) & 2015/863/EU (RoHS 3) compliant.
 2. See <https://www.diodes.com/quality/lead-free/> for more information about Diodes Incorporated's definitions of Halogen- and Antimony-free, "Green" and Lead-free.
 3. Halogen- and Antimony-free "Green" products are defined as those which contain <900ppm bromine, <900ppm chlorine (<1500ppm total Br + Cl) and <1000ppm antimony compounds.

Applications

- Non-Isolated Home Appliances: AC Fans, Rice Cookers, Shavers; Milk Machines
- IoT Applications
- Industrial Controls
- Standby and Auxiliary

Typical Applications Circuit

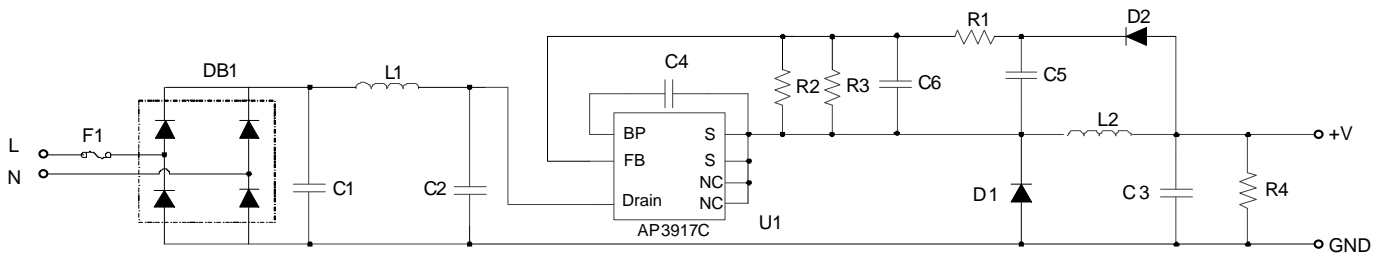

Pin Descriptions

Pin Number	Pin Name	Function
1, 2	N/C	Not Connected Internally. Recommend to connect to Source for better heat dissipation.
3, 4	S	Internal Power MOSFET Source. Ground Reference for BP and FB Pins.
5	BP	Connection Point of External Bypass Capacitor for Internally Generated Control Circuit Power Supply.
6	FB	Regulator Feedback.
7	Drain	Internal Power MOSFET Drain. High-Voltage Current Source Input.

Functional Block Diagram

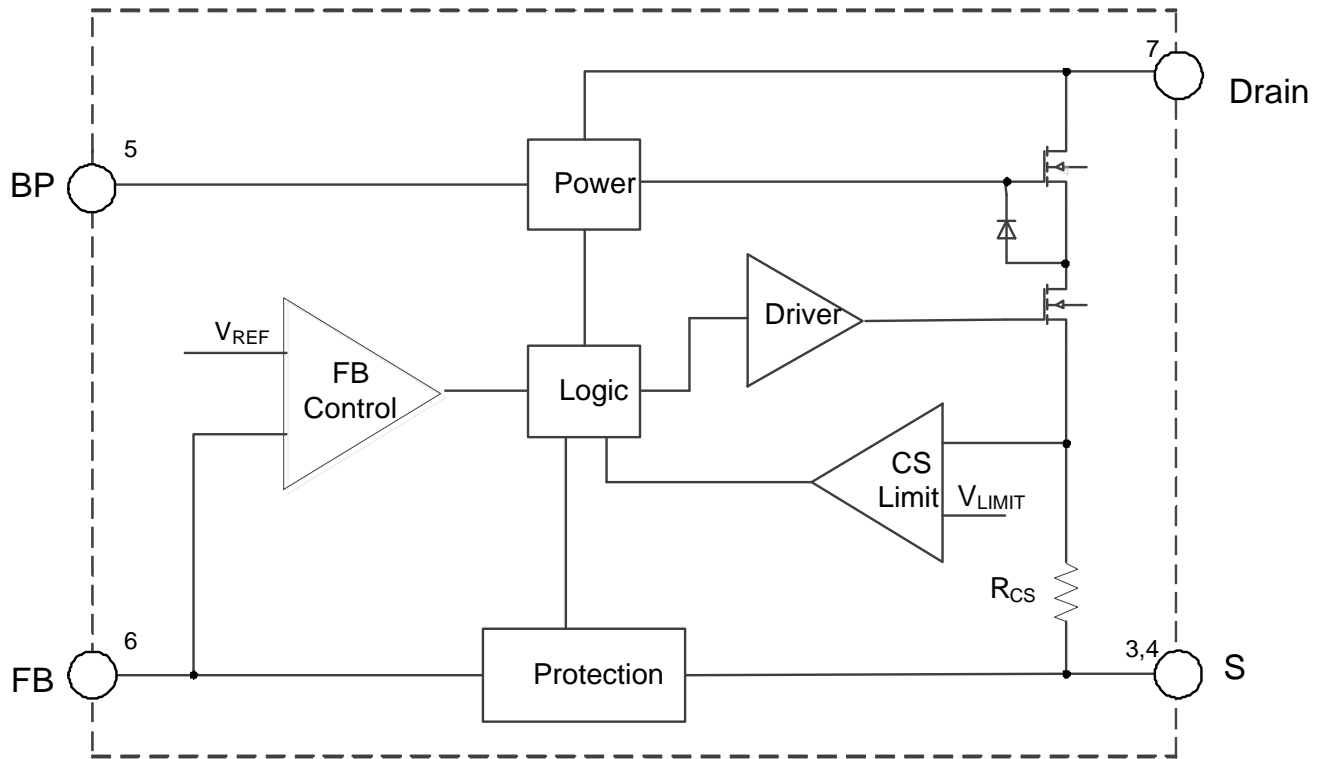

Absolute Maximum Ratings (Note 4)

Symbol	Parameter	Rating	Unit
V_{DSS}	Drain Pin Voltage	-0.7 to 650	V
V_{BP}	Internally Generated Control Circuit Power Supply Voltage	8.9	V
V_{FB}, V_S	FB Pin Voltage and S Pin Voltage	-0.7 to 5.5	V
P_D	Continuous Power Dissipation ($T_A = +25^\circ\text{C}$)	1	W
T_J	Operating Junction Temperature	+150	$^\circ\text{C}$
T_{STG}	Storage Temperature	-65 to +150	$^\circ\text{C}$
T_{LEAD}	Lead Temperature (Soldering, 10s)	+300	$^\circ\text{C}$
θ_{JA}	Thermal Resistance (Junction to Ambient) (Note 5)	95	$^\circ\text{C/W}$
θ_{JC}	Thermal Resistance (Junction to Case)	13.5	$^\circ\text{C/W}$
—	ESD (Human Body Model)	4000	V
—	ESD (Charge Device Model)	1000	V

- Notes: 4. Stresses greater than those listed under *Absolute Maximum Ratings* can cause permanent damage to the device. These are stress ratings only, and functional operation of the device at these or any other conditions beyond those indicated under *Recommended Operating Conditions* is not implied. Exposure to *Absolute Maximum Ratings* for extended periods can affect device reliability.
 5. Test condition: Device mounted on FR-4 substrate PC board, 2oz copper, with 1inch² cooling area.

Recommended Operating Conditions

Symbol	Parameter	Min	Max	Unit
V _{CC}	Supply Voltage	8.2	8.8	V
V _{DSS}	Drain-Source Voltage (Note 6)	—	520	V
T _A	Ambient Temperature	-40	+125	°C

Electrical Characteristics (V_{BP} = 8.2V, -40°C < T_A < +125°C, unless otherwise specified.)

Symbol	Parameter	Condition	Min	Typ	Max	Unit
HV Startup Current Source						
I _{HV}	HV Supply Current	V _{BP} = 7V, V _{DRAIN} = 100V	—	3.5	—	mA
I _{LEAK}	Leakage Current of Drain	V _{BP} = 8.7V; V _{DRAIN} = 400V, T _A = +25°C	—	10	12	μA
V_{BP} Voltage Management						
V _{BP_HVOFF}	V _{BP} Increasing Level at which HV Supply is OFF	—	8.1	8.5	8.8	V
V _{BP_HVON}	V _{BP} Decreasing Level at which HV Supply is ON	—	7.8	8.2	8.6	V
V _{BP_HYS}	V _{BP} Hysteresis (V _{BP_HVOFF} — V _{BP_HVON})	—	—	280	—	mV
V _{BP_UVLO}	V _{BP} Minimum Operating Voltage	T _A = +25°C	—	6.5	—	V
V _{BP_RESTART}	V _{BP} Restart Voltage	—	—	4.5	—	V
I _{BP1}	V _{BP} Operating Current with MOSFET Switching	V _{BP} = 8.5V, f = 37kHz, D = 40%, T _A = +25°C	—	—	350	μA
I _{BP2}	V _{BP} Quiescent Current with No Switching	T _A = +25°C	—	110	200	μA
I _{BP_LATCH}	V _{BP} Latch Off-Current	V _{BP} = 8.8V, T _A = +25°C	—	26	—	μA
Internal MOSFET						
V _{DS}	Breakdown Voltage	(Note 6) T _A = +25°C	650	—	—	V
R _{DS(ON)}	ON Resistance	T _A = +25°C, I _D = 0.4A	—	—	16	Ω
Internal Current Sense						
I _{PK_MAX}	Maximum Peak Current	T _A = +25°C	357	420	483	mA
t _{LEB1}	Leading-Edge Blanking	T _A = +25°C	—	250	400	ns
I _{SCP}	Current Set Point for Short Circuit Protection	T _A = +25°C	510	600	690	mA
t _{LEB2}	Leading-Edge Blanking for Short Circuit Protection	T _A = +25°C	—	200	—	ns
Feedback Input (FB Pin)						
t _{MINOFF}	Minimum Off-Time	T _A = +25°C	12.5	17.5	22.5	μs
V _{FB}	Feedback Voltage for MOSFET Switch-On Threshold	—	2.4	2.5	2.6	V
V _{FB_OLP}	Feedback Voltage for Overload Protection Trigger Threshold	—	1.56	1.7	1.84	V
t _{OLP}	Overload Protection Delay Time	f = 36kHz	—	170	—	ms
V _{OLD}	Open-Loop Detection Voltage	T _A = +25°C	—	60	—	mV
t _{OLD}	Open-Loop Detection Blanking Time	f = 15kHz, T _A = +25°C	—	4.3	—	ms
Over Temperature Protection						
T _{OTP}	Thermal Shutdown Threshold (Note 7)	—	+135	+150	+165	°C

Notes: 6. The drain-source voltage is 80% of V_{DS} in the aging condition.
7. Guaranteed by design.

Performance Characteristics

FB Voltage vs. Ambient Temperature

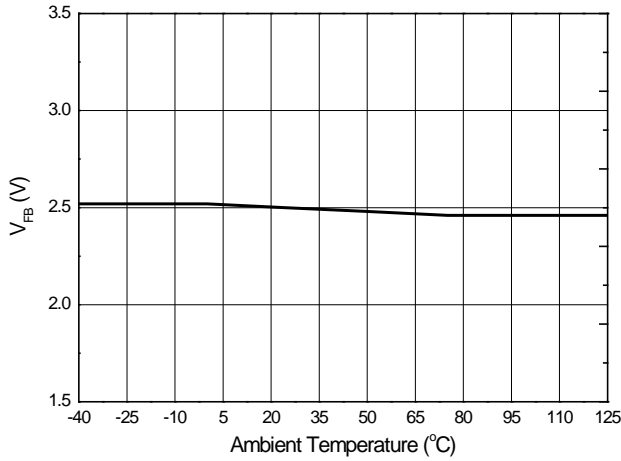

V_{BP_HVON} Voltage vs. Ambient Temperature

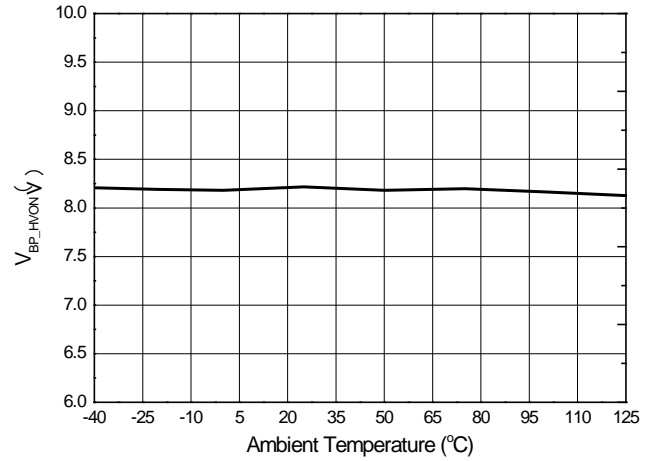

V_{BP_HVOFF} Voltage vs. Ambient Temperature

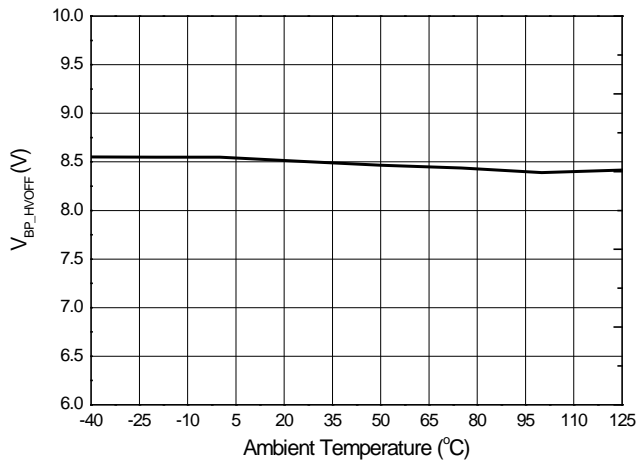

R_{DS(ON)} vs. Ambient Temperature

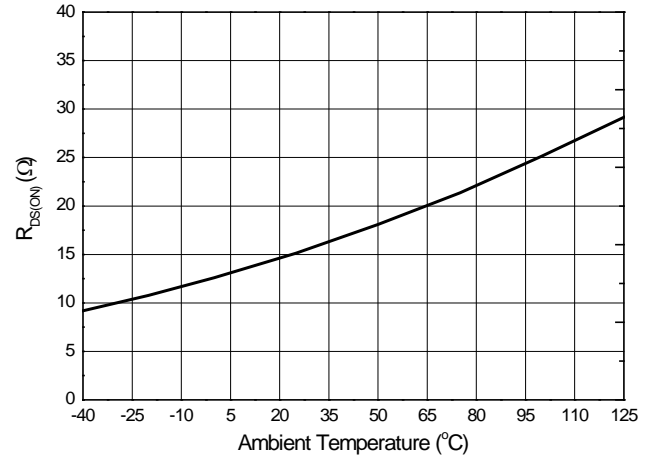

Operation Description

Overall Introduction

The AP3917C is a universal AC input step-down power switcher. Peak current and switching frequency reduce as the load decreases, so the device can get excellent efficiency performance at light load and improve the overall system efficiency. Coordinating with an external single-winding inductor can achieve a low BOM cost solution.

V_{BP} Waveform and ON/OFF Control

The AP3917C control circuit power supply voltage V_{BP} is charged by the internal high-voltage regulator. When the BP voltage is charged to V_{BP_HVOFF} (8.5V), the IC starts up, and the internal high-voltage regulator is turned off. When the BP voltage drops below V_{BP_HVON} (8.2V), the internal high-voltage regulator turns on again to charge the external BP capacitor.

When fault conditions happen, such as some protections like overload faults, short-circuit faults, over temperature faults, and open-loop faults, the AP3917C stops switching. Afterwards, an internal current source I_{BP_LATCH} discharges the external BP capacitor. The internal high-voltage regulator will not turn on again until the voltage on BP capacitor drops below V_{BP_RESTART} (4.5V). The restart time interval is proportional to the capacitance of external BP capacitor—the larger capacitance of the external BP capacitor, the longer restart time.

The restart time after a fault is about

$$t_{RESTART} = C_{BP} \times \left(\frac{V_{BP_FAULT} - V_{BP_RESTART}}{I_{BP_LATCH}} + \frac{V_{BP_HVOFF} - V_{BP_RESTART}}{I_{HV}} \right)$$

Where:

- V_{BP_FAULT} is actual voltage value of BP pin at the time of fault, which is between V_{BP_HVON} and V_{BP_HVOFF}

Figure 1 shows the typical waveform of V_{BP}.

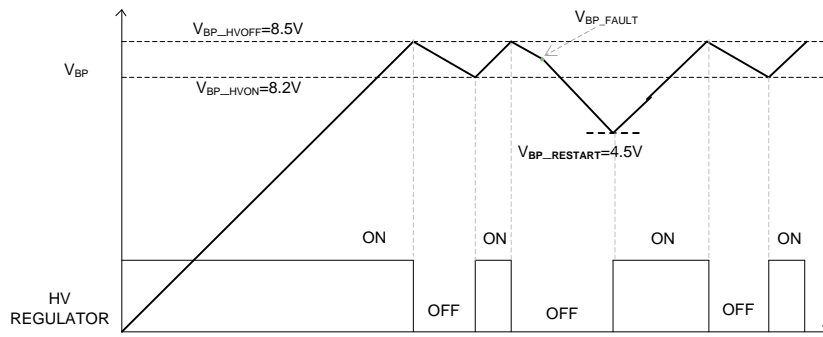

Figure 1. V_{BP} Waveform and HV Regulator ON/OFF Status

Auxiliary V_{BP} Supply

If the output voltage is higher than the voltage of V_{BP_HVON}, an auxiliary V_{BP} supply can be implemented to reduce overall power consumption by connecting a resistor (R5) between C4 and C5. A standby power of less than 30mW can be achieved especially in a no-load condition.

Figure 2 shows the low standby power circuit with the auxiliary V_{BP} supply.

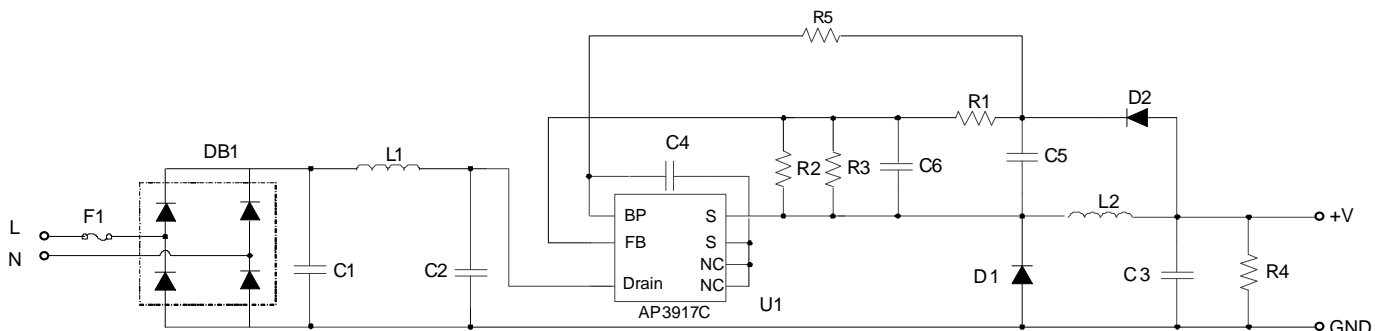

Figure 2. Low Standby Power Circuit with Auxiliary V_{BP} Supply

Operation Description (continued)

The value of R5 can be determined by the following equation:

$$R5 = \frac{V_O - V_{BP_HVON}}{I_{BP2}}$$

Constant Voltage Operation

The AP3917C can be used in a buck circuit as shown in the typical application circuit. In the beginning of each cycle, the internal integrated MOSFET turns ON when the FB voltages fall below the reference voltage V_{FB} (2.5V). The FB voltage is derived from the sampling capacitor voltage, which can reflect output voltage.

The ON period time is determined by the inductor current variable value ΔI_L , (ΔI_L is the gap of the peak-current limitation value I_{PK} and the initial inductor current value I_{INI}), the inductance value, and the input voltage. The ON time calculation is as follows:

$$t_{ON} = L \cdot \frac{\Delta I_L}{V_{IN_DC}} = L \cdot \frac{I_{PK} - I_{INI}}{V_{IN_DC}}$$

Where I_{INI} is zero in DCM status.

When the inductor current reaches the peak current limitation, the internal MOSFET will turn off. The inductor current charges the sampling capacitor (C5) and the output capacitor (C3) via the freewheeling diode D2 and D1 respectively. In this stage, the sampling capacitor voltage reflects the output voltage.

The output voltage can be regulated by sampling the FB voltage. In the MOSFET OFF time, the inductor current decreases linearly from peak current. When the inductor current falls below the output current, the FB voltage begins to decrease with the sampling capacitor voltage. Once the FB voltage is detected below the reference voltage of primary MOSFET turn-on threshold, a new switching cycle starts.

The regulated output voltage can be described as the following equation:

$$V_O = V_{FB} \times \left(\frac{R_1 + R_2}{R_2} \right)$$

Figures 3(a) and 3(b) show the operation diagram under DCM and CCM.

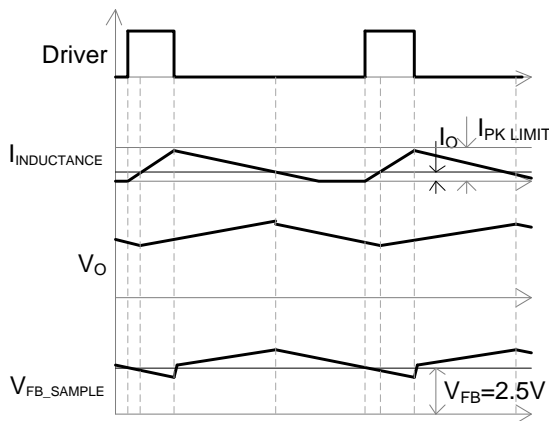

Figure 3(a). DCM

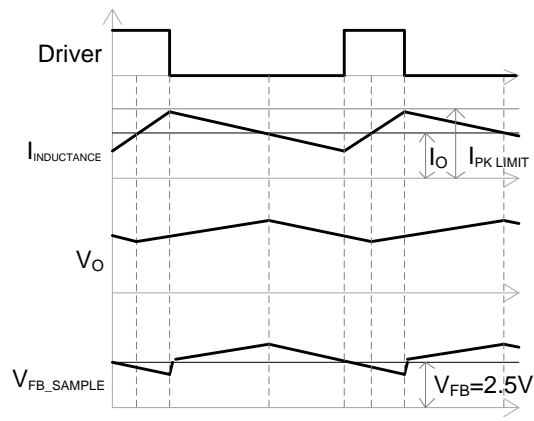

Figure 3(b).CCM

Startup Control

A three-stage control method is designed for soft start function in startup process. During these stages, the OFF time reduces from 70µs to 35µs in stage I, then from 35µs to 17.5µs (t_{MINOFF}) in stage II. Every stage has 128 switching cycles (see Figure 4), but once the output voltage reaches the rated value, the startup process ends no matter what stage it is then AP3917C enters normal operation mode.

Operation Description (continued)

Figure 4 describes the driver time sequence.

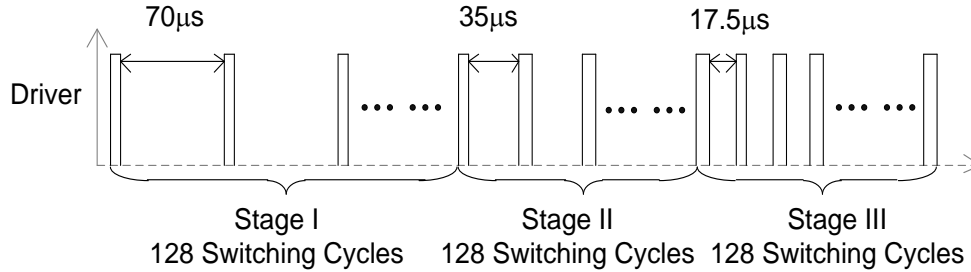

Figure 4. Driver Time Sequence in Startup Process

Operation Frequency and Peak Current Characteristics

In order to achieve excellent efficiency performance at light load and improve the overall system efficiency, AP3917C utilizes an optimized frequency curve as is shown in Figure 5. By means of increasing MOSFET off time, switching frequency continuously decreases as the load decrease, which is optimized for the better light load efficiency. The peak current also decreases with load decreases, which can avoid the audio noise when frequency enters into audio frequency range.

The switching-frequency equation is as follows:

$$f_s = \left(\frac{V_{IN} - V_o}{V_{IN}}\right) \cdot \frac{V_o}{2 \cdot L \cdot (I_{PK} - I_o)}, \text{ for } CCM$$

$$f_s = \left(\frac{V_{IN} - V_o}{V_{IN}}\right) \cdot \frac{2 \cdot V_o \cdot I_o}{L \cdot I_{PK}^2}, \text{ for } DCM$$

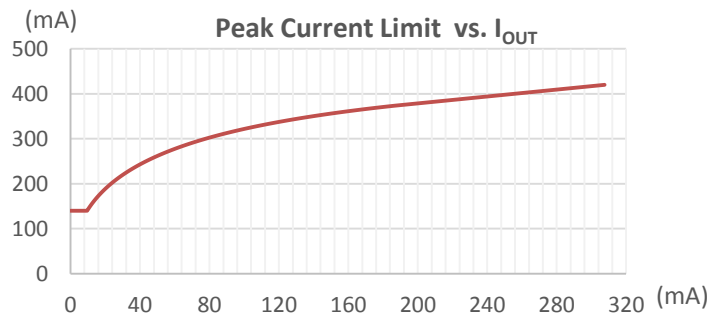
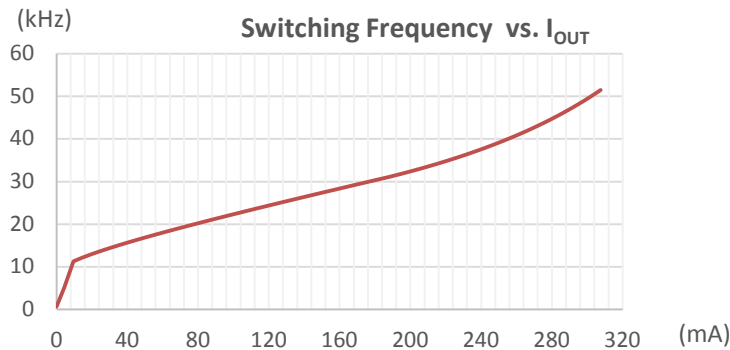

Figure 5. Frequency and Peak Current Limit Characteristic (Vo=12V, L1=1mH)

Operation Description (continued)

Overload Protection (OLP)

With the increase of load, the peak current and the switching frequency increase. When the peak current reaches the maximum limitation, and the OFF time is the minimum OFF time, the output voltage drops if the load continues to increase. Similarly, the FB voltage decreases as the output voltage drops. When FB voltage drops below OLP threshold V_{FB_OLP} (1.7V), the internal timer of overload starts to count. Once the overload duration lasts more than the OLP delay time t_{OLP} (170ms), the OLP occurs.

The time delay setting of OLP should avoid triggering OLP when the system starts up or enters a load transition phase. Therefore it requires that the system startup time must be less than t_{OLP} . The 170ms time delay of t_{OLP} is calculated under the condition of 36kHz operating frequency. The different operating frequency corresponds to different time delay, the time delay calculation under different operating frequency (f_s) as follows:

$$t_{DELAY} \approx 170ms \times \left(\frac{36kHz}{f_s}\right)$$

Short-Circuit Protection (SCP)

The AP3917C shuts down when the peak current exceeds short-circuit threshold, and the AP3917C resumes operation when the fault is removed.

Over Temperature Protection (OTP)

The AP3917C integrates an internal over-temperature protection function. The AP3917C shuts down when the inner junction temperature exceeds thermal shutdown threshold T_{OTP} (+150°C). After exceeding the threshold, the BP voltage begins to drop, and when BP voltage drops to $V_{BP_RESTART}$ (4.5V), the internal high-voltage regulator turns on to charge the external BP capacitor.

Open-Loop Detection

When the FB voltage drops below open-loop detection threshold voltage V_{OLD} (60mV), the AP3917C stops working and begins a restart cycle. The open-loop detection is blanked for 64 switching cycles during startup process.

Overshoot Improvement

In general, there is no capacitor between FB pin and S pin. But in some cases where strict overshoot is required, we recommend a ceramic capacitor C6 (390pF to 1nF) in Figure 6.

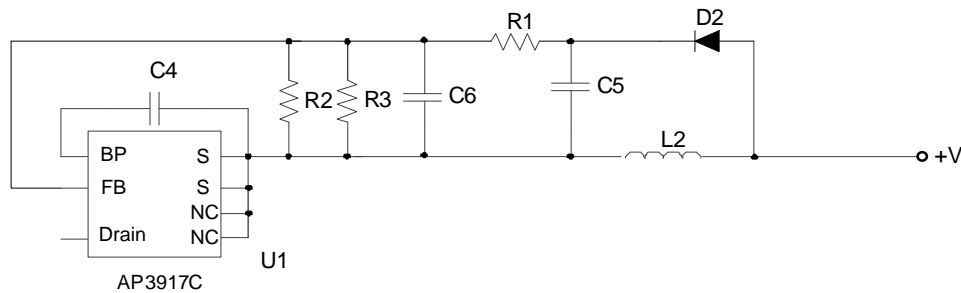
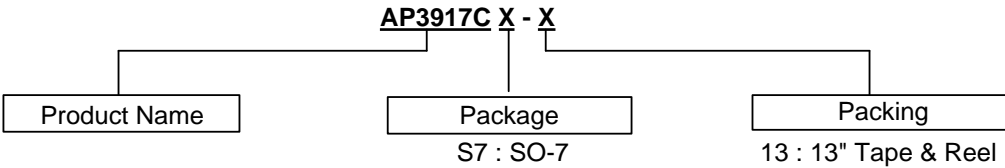

Figure 6. Overshoot Improvement

Leading-Edge Blanking

A narrow spike on the leading edge of the current waveform can usually be observed when the power MOSFET is turned on. Normally, the leading-edge blanking time t_{LEB1} is built in to prevent the false-triggering caused by the turn-on spike. But in the case of short circuit, the leading-edge blanking time is t_{LEB2} . During this period, the current limit comparator is disabled, and the gate driver cannot be switched off.

Ordering Information



Package	Part Number	Marking ID	Packing
SO-7	AP3917CS7-13	3917C	4000/Tape & Reel

Marking Information

Package Type: SO-7

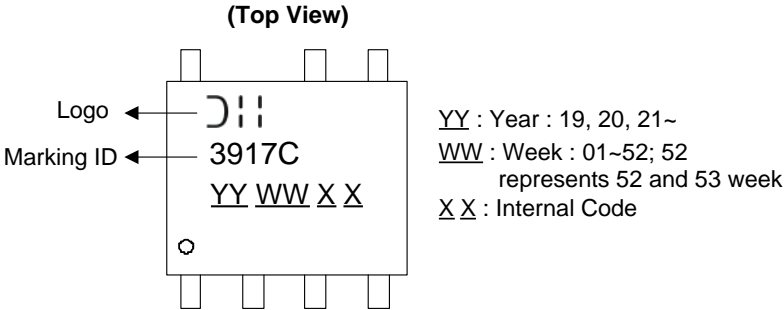

Package Outline Dimensions

Please see <http://www.diodes.com/package-outlines.html> for the latest version.

SO-7

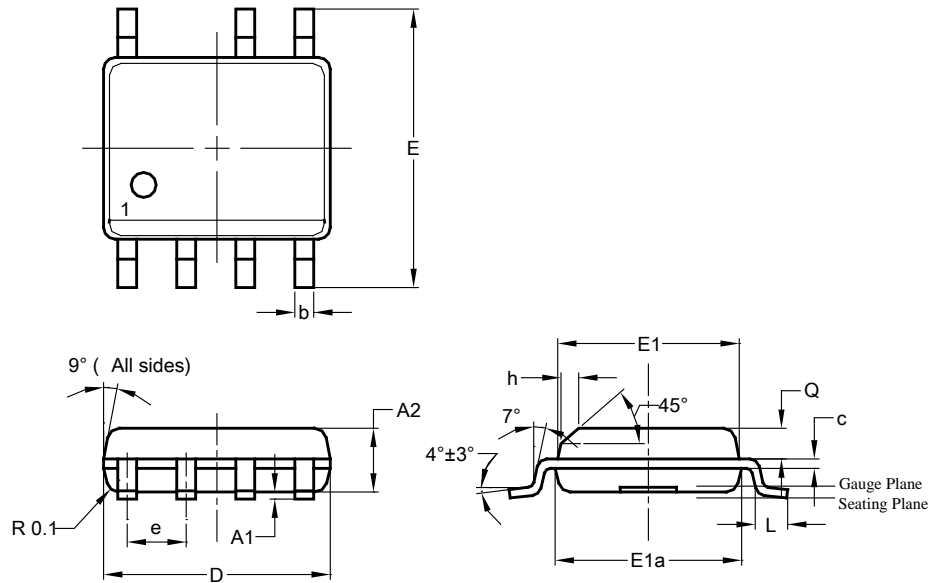

SO-7			
Dim	Min	Max	Typ
A2	1.40	1.50	1.45
A1	0.10	0.20	0.15
b	0.30	0.50	0.40
c	0.15	0.25	0.20
D	4.85	4.95	4.90
E	5.90	6.10	6.00
E1	3.80	3.90	3.85
E1a	3.85	3.95	3.90
e	—	—	1.27
h	—	—	0.35
L	0.62	0.82	0.72
Q	0.60	0.70	0.65
All Dimensions in mm			

Suggested Pad Layout

Please see <http://www.diodes.com/package-outlines.html> for the latest version.

SO-7

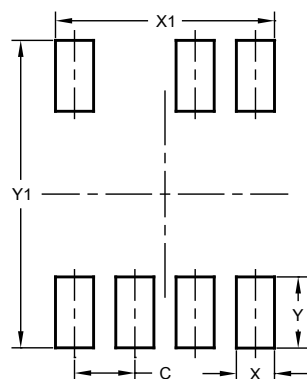

Dimensions	Value (in mm)
C	1.270
X	0.802
X1	4.612
Y	1.505
Y1	6.500

IMPORTANT NOTICE

DIODES INCORPORATED MAKES NO WARRANTY OF ANY KIND, EXPRESS OR IMPLIED, WITH REGARDS TO THIS DOCUMENT, INCLUDING, BUT NOT LIMITED TO, THE IMPLIED WARRANTIES OF MERCHANTABILITY AND FITNESS FOR A PARTICULAR PURPOSE (AND THEIR EQUIVALENTS UNDER THE LAWS OF ANY JURISDICTION).

Diodes Incorporated and its subsidiaries reserve the right to make modifications, enhancements, improvements, corrections or other changes without further notice to this document and any product described herein. Diodes Incorporated does not assume any liability arising out of the application or use of this document or any product described herein; neither does Diodes Incorporated convey any license under its patent or trademark rights, nor the rights of others. Any Customer or user of this document or products described herein in such applications shall assume all risks of such use and will agree to hold Diodes Incorporated and all the companies whose products are represented on Diodes Incorporated website, harmless against all damages.

Diodes Incorporated does not warrant or accept any liability whatsoever in respect of any products purchased through unauthorized sales channel. Should Customers purchase or use Diodes Incorporated products for any unintended or unauthorized application, Customers shall indemnify and hold Diodes Incorporated and its representatives harmless against all claims, damages, expenses, and attorney fees arising out of, directly or indirectly, any claim of personal injury or death associated with such unintended or unauthorized application.

Products described herein may be covered by one or more United States, international or foreign patents pending. Product names and markings noted herein may also be covered by one or more United States, international or foreign trademarks.

This document is written in English but may be translated into multiple languages for reference. Only the English version of this document is the final and determinative format released by Diodes Incorporated.

LIFE SUPPORT

Diodes Incorporated products are specifically not authorized for use as critical components in life support devices or systems without the express written approval of the Chief Executive Officer of Diodes Incorporated. As used herein:

A. Life support devices or systems are devices or systems which:

1. are intended to implant into the body, or
2. support or sustain life and whose failure to perform when properly used in accordance with instructions for use provided in the labeling can be reasonably expected to result in significant injury to the user.

B. A critical component is any component in a life support device or system whose failure to perform can be reasonably expected to cause the failure of the life support device or to affect its safety or effectiveness.



Customers represent that they have all necessary expertise in the safety and regulatory ramifications of their life support devices or systems, and acknowledge and agree that they are solely responsible for all legal, regulatory and safety-related requirements concerning their products and any use of Diodes Incorporated products in such safety-critical, life support devices or systems, notwithstanding any devices- or systems-related information or support that may be provided by Diodes Incorporated. Further, Customers must fully indemnify Diodes Incorporated and its representatives against any damages arising out of the use of Diodes Incorporated products in such safety-critical, life support devices or systems.

Copyright © 2020, Diodes Incorporated

www.diodes.com

Looking for pricing, stock, or lifecycle information?

Click below to explore more details on WIN SOURCE:

-  [View AP3917CS7-13 on WIN SOURCE](#)
-  [Diodes Incorporated Information](#)

Optimize Your Supply Chain with WIN SOURCE Solutions

-  Global Sourcing Solution
-  Obsolete Management
-  Cost Control Management
-  Shortage Management
-  Alternative Solution
-  Excess Inventory Management