

JCK Series



- 2:1 Input Range
- Very High Power Density
- Single and Dual Outputs
- High Efficiency – Up to 92%
- Remote On/Off
- 1600 VDC Isolation
- 3 Year Warranty

Specification

Input

Input Voltage Range	<ul style="list-style-type: none"> • 12 V (9-18 VDC), 24 V (18-36 VDC), 48 V (36-75 VDC)
Input Current	<ul style="list-style-type: none"> • See table
Input Reflected Ripple Current	<ul style="list-style-type: none"> • 20 mA pk-pk through 12 μH inductor, 5 Hz to 20 MHz
Undervoltage Lockout	<ul style="list-style-type: none"> • 12 V models: ON 8.6 V, OFF 7.9 V typical • 24 V models: ON 17.8 V, OFF 16 V typical • 48 V models: ON 33.5 V, OFF 30.5 V typical
Input Surge	<ul style="list-style-type: none"> • 12 V models 25 VDC for 1000 ms • 24 V models 50 VDC for 1000 ms • 48 V models 100 VDC for 1000 ms

Output

Output Voltage	<ul style="list-style-type: none"> • See table
Output Voltage Trim	<ul style="list-style-type: none"> • $\pm 10\%$ on single outputs models only, contact sales for details
Minimum Load	<ul style="list-style-type: none"> • No minimum load required
Line Regulation	<ul style="list-style-type: none"> • $\pm 0.5\%$ max
Load Regulation	<ul style="list-style-type: none"> • Single output models: $\pm 0.5\%$ max • Dual output models: $\pm 1\%$ max balanced outputs
Cross Regulation	<ul style="list-style-type: none"> • $\pm 5\%$ (see note 2)
Setpoint Accuracy	<ul style="list-style-type: none"> • $\pm 1\%$
Start Up Time	<ul style="list-style-type: none"> • 30 ms typical
Ripple & Noise	<ul style="list-style-type: none"> • 100 mV for 3V3 +5V models, 150 mV for other models (see note 3)
Transient Response	<ul style="list-style-type: none"> • 3% max deviation, recovery to within 1% in $<250 \mu$s for a 25% load change
Temperature Coefficient	<ul style="list-style-type: none"> • 0.02%/$^{\circ}$C
Overvoltage Protection	<ul style="list-style-type: none"> • 3.3 V models: 3.9 V typical • 5 V models: 6.2 V typical • 12 V models: 15 V typical • 15 V models: 18 V typical • ± 12 V models: ± 15 V typical • ± 15 V models: ± 18 V typical
Overload Protection	<ul style="list-style-type: none"> • 115-130% of output current
Short Circuit Protection	<ul style="list-style-type: none"> • Trip & restart (Hiccup mode), auto recovery
Remote On/Off	<ul style="list-style-type: none"> • On = Logic High (>3.0) or Open • Off = Logic Low (<1.2 V) or short pin 2 to 3

General

Efficiency	<ul style="list-style-type: none"> • See table
Isolation	<ul style="list-style-type: none"> • 1600 VDC Input to Output • 1600 VDC Input to Case • 1600 VDC Output to Case
Isolation Capacitance	<ul style="list-style-type: none"> • 1000 pF typical
Switching Frequency	<ul style="list-style-type: none"> • 270 kHz typical
Power Density	<ul style="list-style-type: none"> • 50 W/in³
MTBF	<ul style="list-style-type: none"> • 330 kHrs min to MIL-HDBK-217F at 25 $^{\circ}$C, GB

Environmental

Operating Temperature	<ul style="list-style-type: none"> • -40 $^{\circ}$C to +70 $^{\circ}$C, derate from 100% load at 55 $^{\circ}$C to 60% load at 70 $^{\circ}$C
Case Temperature	<ul style="list-style-type: none"> • +105 $^{\circ}$C max
Cooling	<ul style="list-style-type: none"> • Convection-cooled
Operating Humidity	<ul style="list-style-type: none"> • 5-95% RH, non-condensing
Storage Temperature	<ul style="list-style-type: none"> • -40 $^{\circ}$C to +125 $^{\circ}$C

EMC

Emissions	<ul style="list-style-type: none"> • EN55022 class B conducted & radiated with external components, see application note
ESD Immunity	<ul style="list-style-type: none"> • EN61000-4-2, 4 kV contact discharge, Perf Criteria B
Radiated Immunity	<ul style="list-style-type: none"> • EN61000-4-3, 3 V/m, Perf Criteria A
EFT/Burst	<ul style="list-style-type: none"> • EN61000-4-4, level 1, Perf Criteria A*
Surge	<ul style="list-style-type: none"> • EN61000-4-5, level 1, Perf Criteria A
Conducted Immunity	<ul style="list-style-type: none"> • EN61000-4-6, 3 Vrms, Perf Criteria A
Magnetic Field	<ul style="list-style-type: none"> • EN61000-4-8, 1 A/m, Perf Criteria A

Safety

Safety Approvals	<ul style="list-style-type: none"> • CE (Meets all applicable directives), UKCA (Meets all applicable legislation)
------------------	---

*External input capacitor required, 220 μ F/100 V.

Input Voltage	Output Voltage	Output Current	Input Current ⁽¹⁾		Maximum Capacitive Load	Efficiency	Model Number
			No Load	Full Load			
9-18 VDC	3.3 V	8.00 A	100 mA	2444 mA	21000 µF	90%	JCK4012S3V3
	5.0 V	8.00 A	150 mA	3663 mA	13000 µF	91%	JCK4012S05
	12.0 V	3.33 A	40 mA	3663 mA	2000 µF	91%	JCK4012S12
	15.0 V	2.67 A	50 mA	3663 mA	1500 µF	91%	JCK4012S15
	±12.0 V	±1.67 A	30 mA	3663 mA	±1200 µF	91%	JCK4012D12
	±15.0 V	±1.33 A	50 mA	3623 mA	±750 µF	92%	JCK4012D15
18-36 VDC	3.3 V	8.00 A	60 mA	1208 mA	21000 µF	91%	JCK4024S3V3
	5.0 V	8.00 A	80 mA	1811 mA	13000 µF	92%	JCK4024S05
	12.0 V	3.33 A	30 mA	1831 mA	2000 µF	91%	JCK4024S12
	15.0 V	2.67 A	40 mA	1811 mA	1500 µF	92%	JCK4024S15
	±12.0 V	±1.67 A	50 mA	1831 mA	±1200 µF	91%	JCK4024D12
	±15.0 V	±1.33 A	40 mA	1811 mA	±750 µF	92%	JCK4024D15
36-75 VDC	3.3 V	8.00 A	40 mA	604 mA	21000 µF	91%	JCK4048S3V3
	5.0 V	8.00 A	60 mA	905 mA	13000 µF	92%	JCK4048S05
	12.0 V	3.33 A	20 mA	915 mA	2000 µF	91%	JCK4048S12
	15.0 V	2.67 A	20 mA	905 mA	1500 µF	92%	JCK4048S15
	±12.0 V	±1.67 A	30 mA	906 mA	±1200 µF	92%	JCK4048D12
	±15.0 V	±1.33 A	40 mA	906 mA	±750 µF	92%	JCK4048D15

Notes

1. Input current specified at nominal input.
2. Cross regulation for duals is ±5% when one output is at 100% and the other is varied between 25% and 100%.
3. Measured with 1 µF ceramic capacitor in parallel with a 10 µF electrolytic across output rails.
4. For heatsink option add '-HK' to the end of the part number.

Mechanical Details

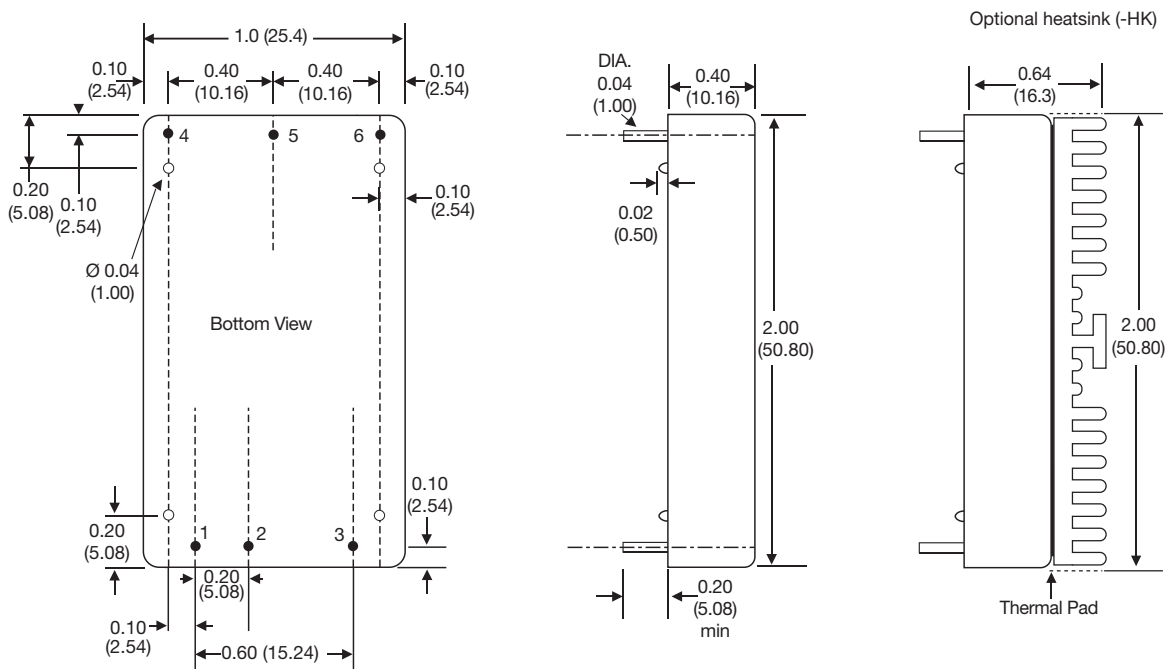

Notes

1. All dimensions are in inches (mm).
2. Weight: 0.07 lbs (30 g) approx
3. Pin diameter: 0.04 ±0.002 (1.0 ±0.05)
4. Pin pitch tolerance: ±0.014 (±0.35)
5. Case tolerance: ±0.02 (±0.5)

Pin	PIN CONNECTIONS	
	Single	Dual
1	+Vin	+Vin
2	-Vin	-Vin
3	Remote On/Off	Remote On/Off
4	+Vout	+Vout
5	Com	Com
6	Trim	-Vout

Input Filter

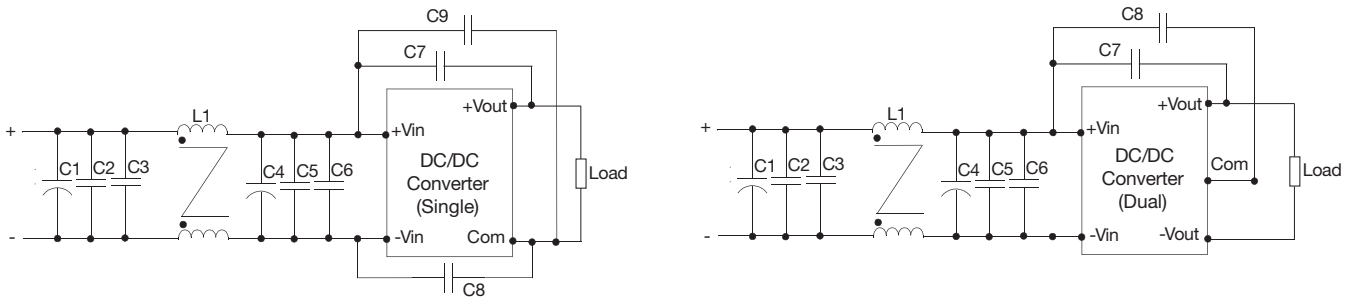

JCK40 Single	C1	L1	C2/C3/C5/C6	C4
12 V	220 μ F, 100 V	Common Mode Choke 68 μ H	6.8 μ F, 50 V	330 μ F, 100 V
24 V			4.7 μ F, 50 V	220 μ F, 100 V
48 V			1.5 μ F, 100 V	220 μ F, 100 V
JCK40 Dual	C1	L1	C2/C3/C5/C6	C4
12 V	220 μ F, 100 V	Common Mode Choke 68 μ H	6.8 μ F, 50 V	330 μ F, 100 V
24 V			4.7 μ F, 50 V	220 μ F, 100 V
48 V			1.5 μ F, 100 V	220 μ F, 100 V

JCK40 Single	C7	C8	C9
12 V	1000 pF, 2 kV	1000 pF, 2 kV	1000 pF, 2 kV
24 V			1000 pF, 2 kV
48 V			1000 pF, 2 kV
JCK40 Dual	C7	C8	
12 V	1000 pF, 2 kV	1000 pF, 2 kV	
24 V			1000 pF, 2 kV
48 V			1000 pF, 2 kV

External Output Trim

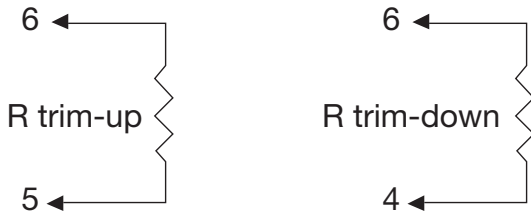

Output can be externally trimmed using this method.
Contact sales for details.

Derating Curves

12 V Input

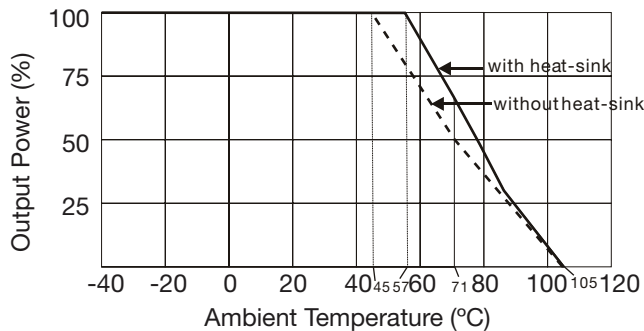

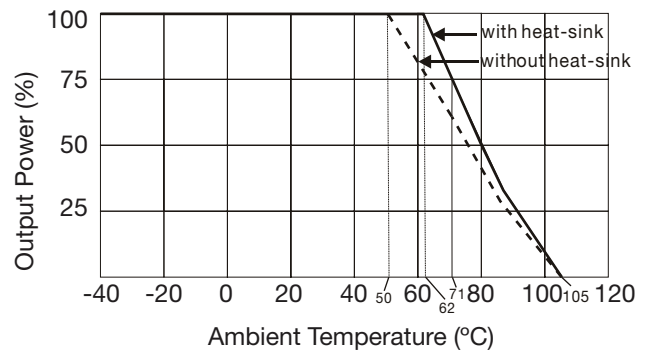

24 & 48 V Input









Looking for pricing, stock, or lifecycle information?

Click below to explore more details on WIN SOURCE:

-  [View JCK4024D12 on WIN SOURCE](#)
-  [XP Power Information](#)

Optimize Your Supply Chain with WIN SOURCE Solutions

-  Global Sourcing Solution
-  Obsolete Management
-  Cost Control Management
-  Shortage Management
-  Alternative Solution
-  Excess Inventory Management