



THE DATASHEET OF BD2270HFV-LBTR



Controller ICs for High Side NMOSFET

BD2270HFV-LB

General Description

This is the product guarantees long time support in Industrial market.
BD2270HFV is an IC with a built-in external N-channel MOSFET driver circuit. This IC has a built-in charge pump circuit for gate drive and output discharge circuit, enabling configuration of a high side load switch for N-channel MOSFET drive without using any external parts.
In addition, the control input terminal has a built-in comparator with hysteresis function, facilitating control of the power up sequence. The space saving type of HVSO5F5 package is used.

Features

- Long time support a product for Industrial applications.
- Built-in charge pump
- Built-in discharge circuit for output charge
- Soft start circuit
- Built-in comparator with hysteresis function at control input terminal
- Possible to drive N-channel power MOSFET

Applications

Industrial Equipment, PCs, PC peripheral devices, digital consumer electronics, etc.

Key Specifications

- Input voltage range: 2.7V to 5.5V
- GATE rise time ($C_{GATE}=500\text{pF}$): 130 μs (Typ.)
- GATE output voltage ($V_{CC}=5\text{V}$): 13.5V (Typ.)
- Operating current: 50 μA (Typ.)
- Standby current: 5 μA (Typ.)
- Operating temperature range: -25°C to +85°C

Package

HVSO5F5

W(Typ.) D(Typ.) H (Max.)
1.60mm x 1.60mm x 0.60mm

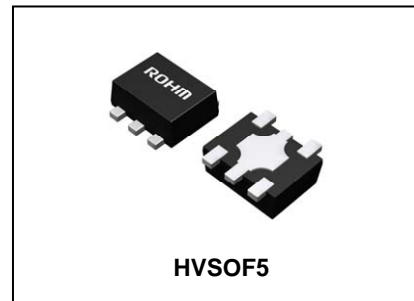

Typical Application Circuit

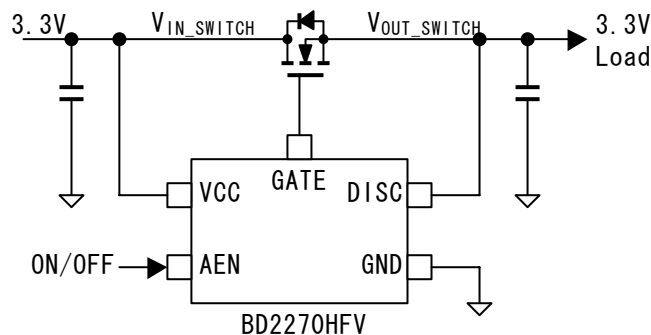

Lineup

GATE output voltage ($V_{CC}=5\text{V}$)			Package		Orderable Part Number
Min.	Typ.	Max.			
10V	13.5V	15V	HVSO5F5	Reel of 3000	BD2270HFV - LBTR

Block Diagram

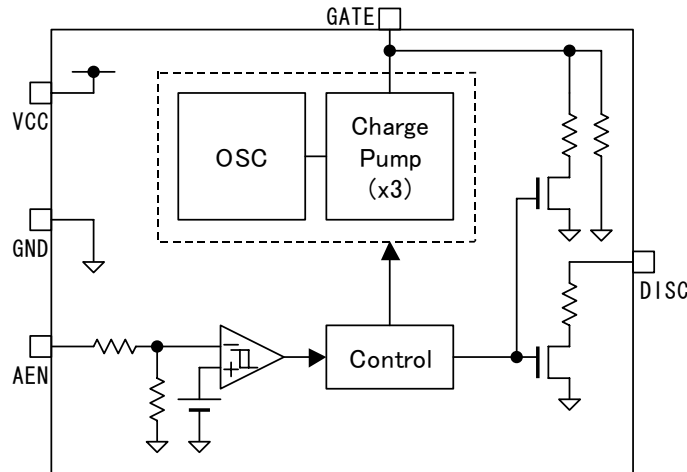

Pin Configuration

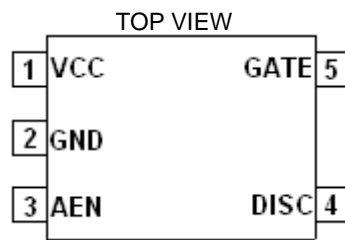

Pin Description

PIN No.	PIN name	I / O	Function
1	VCC	-	Power input terminal
2	GND	-	Ground terminal
3	AEN	I	Control input terminal Turn ON the external MOSFET switch with high level input. High level input > 2.0V, Low level input < 0.8V
4	DISC	O	Switch output discharge terminal
5	GATE	O	GATE drive output terminal Used to connect the gate of the external N-channel MOSFET.

Absolute Maximum Ratings

Parameter	Symbol	Ratings	Unit
Supply voltage	V _{CC}	-0.3 to 6.0	V
AEN voltage	V _{AEN}	-0.3 to 6.0	V
DISC voltage	V _{DISC}	-0.3 to 6.0	V
GATE voltage	V _{GATE}	-0.3 to 15.0	V
Storage temperature range	T _{STG}	-55 to 150	°C
Power dissipation	P _d	669 ^{*1}	mW

*1 When mounted on a 70 mm×70 mm×1.6 mm glass epoxy PCB, derate by 5.352 mW/°C above Ta=25°C

Recommended Operating Conditions

Parameter	Symbol	Ratings	Unit
Operating voltage range	V _{CC}	2.7 to 5.5	V
Operating temperature range	T _{OPR}	-25 to 85	°C

Electrical Characteristics (V_{CC} = 3.0V, Ta = 25°C unless otherwise specified)

Parameter	Symbol	Limits			Unit	Condition
		Min.	Typ.	Max.		
Operating current	I _{CC}	-	50	75	μA	V _{AEN} = 2.5V
Standby current	I _{STB}	-	5	10	μA	V _{AEN} = 0V
AEN input voltage	V _{AENH}	1.55	2	2.45	V	High level input
	V _{AENL}	1.35	1.9	2.35	V	Low level input
AEN input current	I _{AEN}	-	3	5	μA	V _{AEN} = 3V
GATE output voltage	V _{GATE}	10	13.5	15	V	V _{CC} = 5V
		6.6	9.5	9.9	V	V _{CC} = 3.3V
		6	8.5	9	V	V _{CC} = 3V
GATE rise time	T _{ON}	-	130	750	μs	C _{GATE} = 500pF V _{CC} = 3V V _{GATE} > 4V
GATE fall time	T _{OFF}	-	18	60	μs	C _{GATE} = 500pF V _{CC} = 3V V _{GATE} < 0.5V
DISC discharge resistance	R _{DISC}	-	200	300	Ω	V _{AEN} = 0V

Measurement Circuit

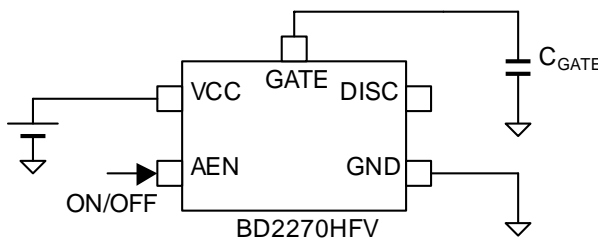

Timing Diagram

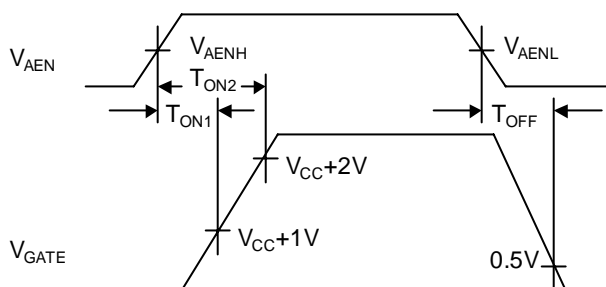

Typical Performance Curves

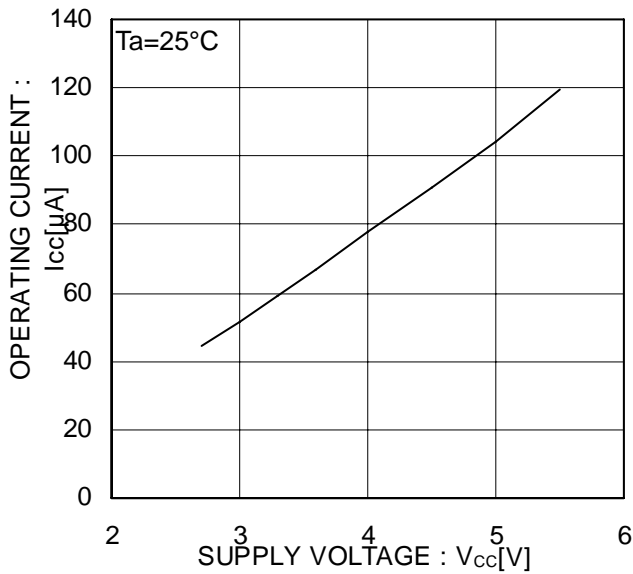

Figure 1. Operating Current
AEN Enable

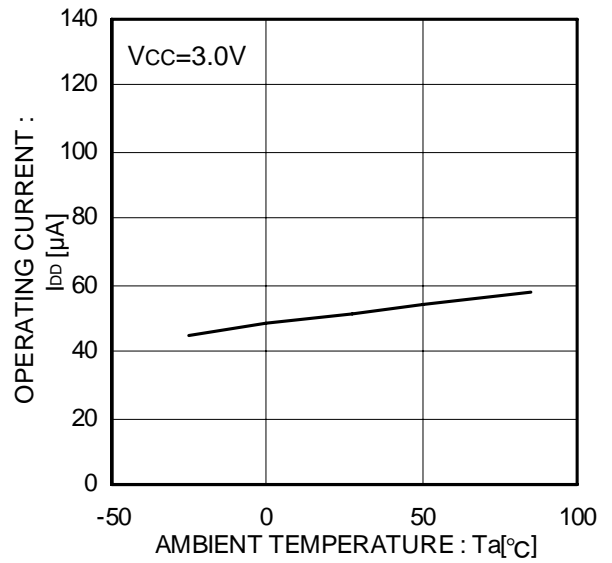

Figure 2. Operating Current
AEN Enable

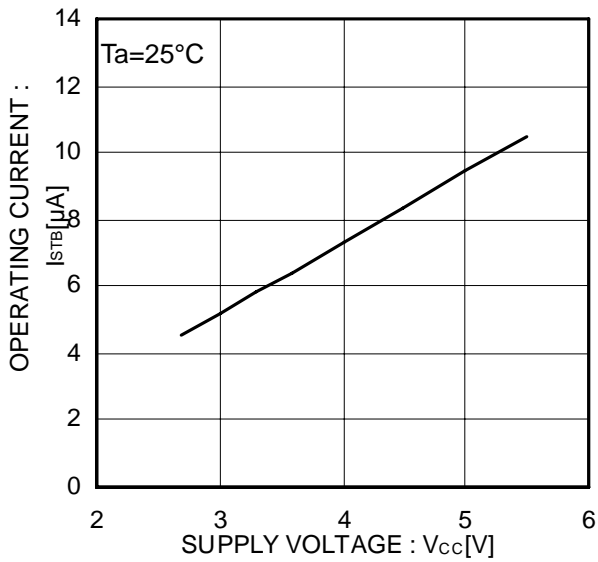

Figure 3. Standby Current
AEN Disable

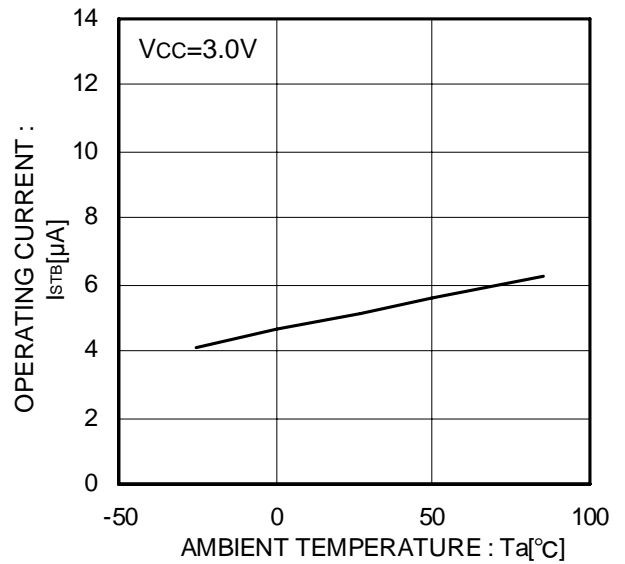

Figure 4. Standby Current
AEN Disable

Typical Performance Curves - continued

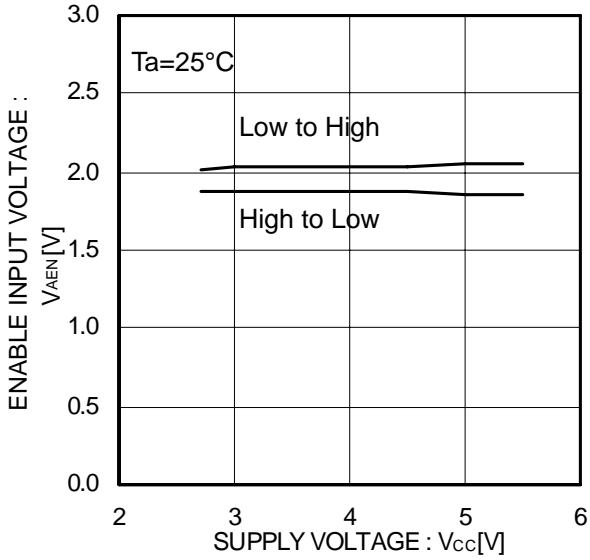

Figure 5. AEN Input Voltage

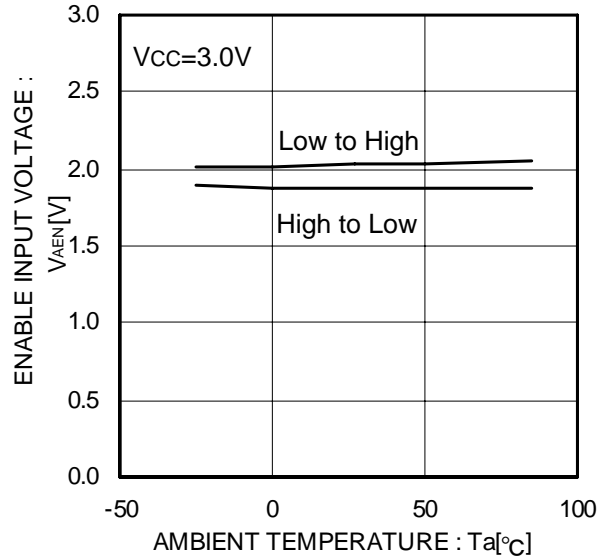

Figure 6. AEN Input Voltage

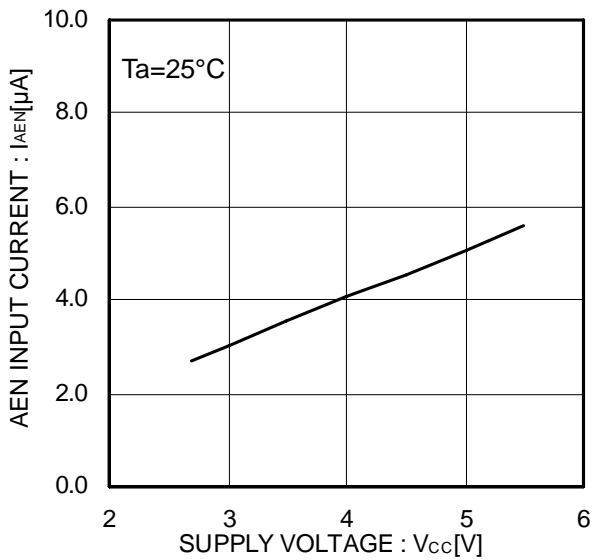

Figure 7. AEN Input Current

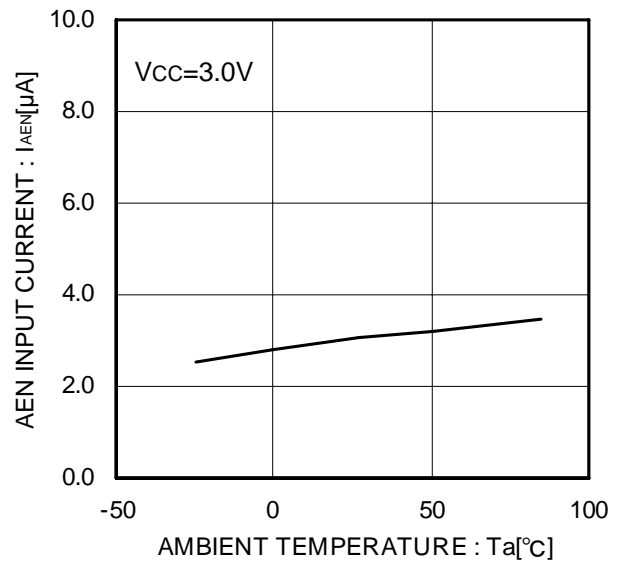

Figure 8. AEN Input Current

Typical Performance Curves - continued

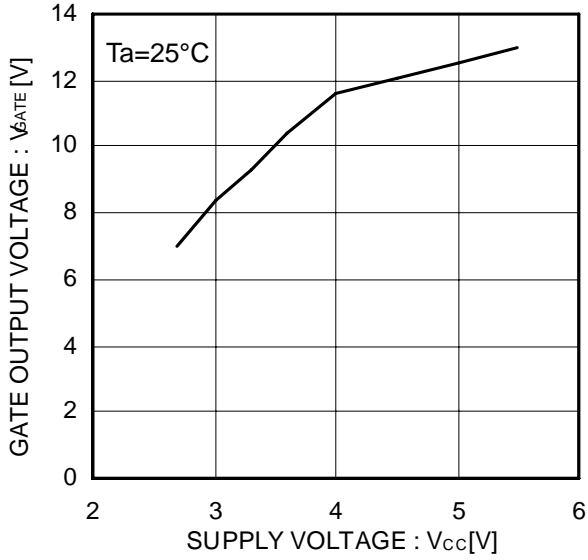

Figure 9. GATE Output Voltage

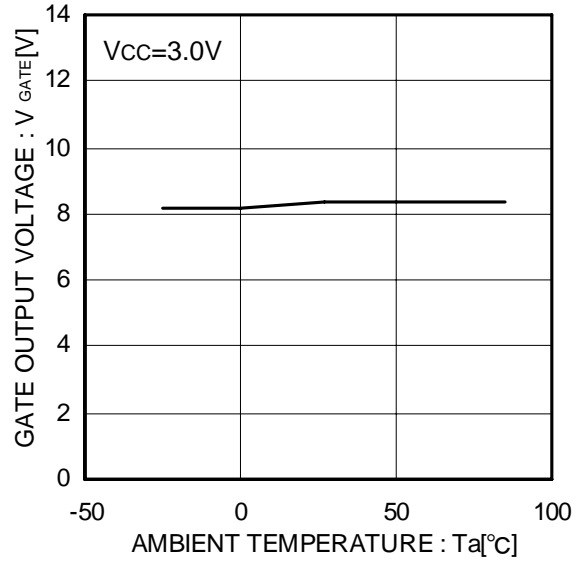

Figure 10. GATE Output Voltage

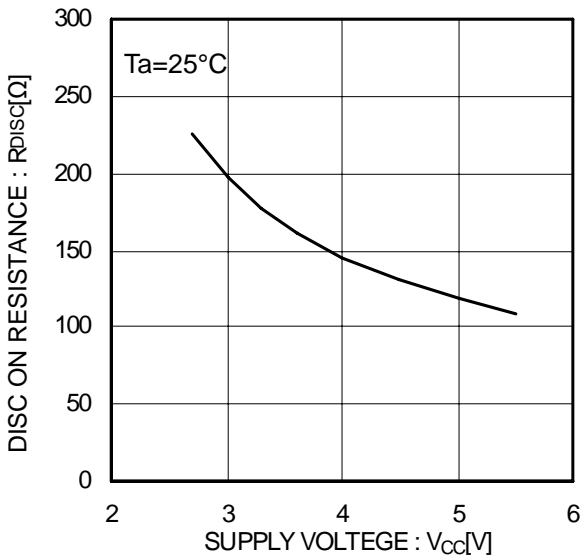

Figure 11. DISC ON Resistance

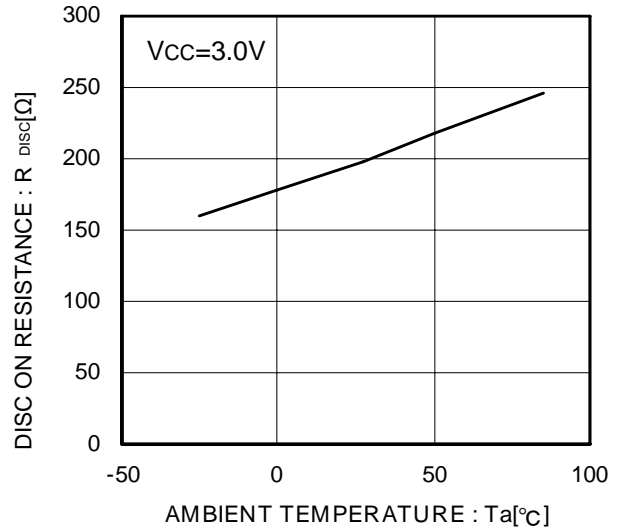

Figure 12. DISC ON Resistance

Typical Performance Curves - continued

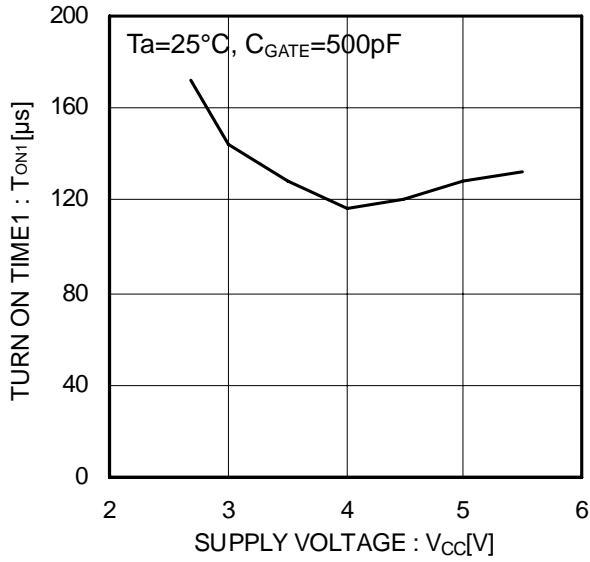

Figure 13. GATE Rise Time 1

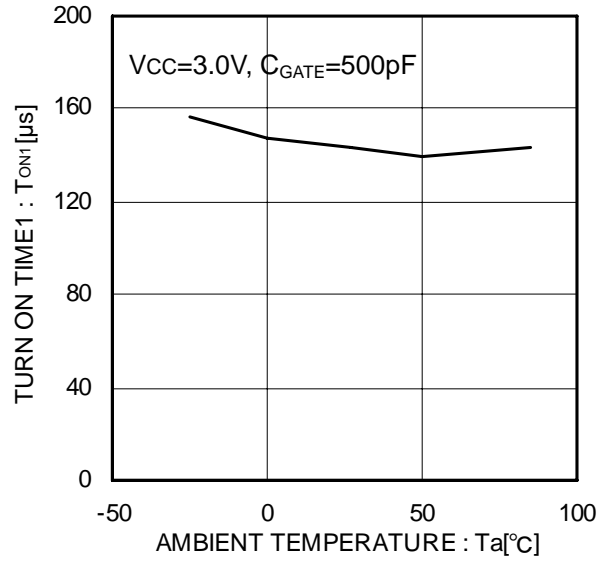

Figure 14. GATE Rise Time 1

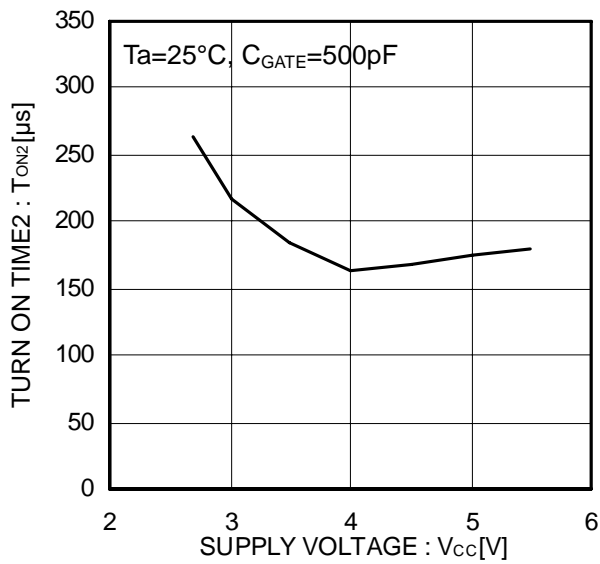

Figure 15. GATE Rise Time 2

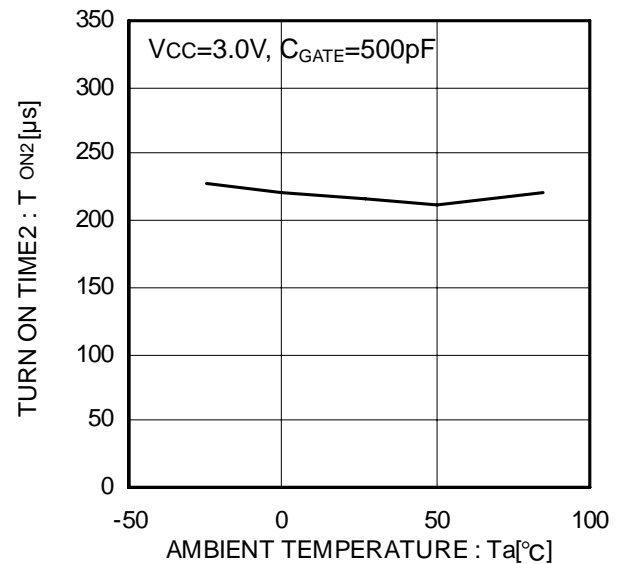

Figure 16. GATE Rise Time 2

Typical Performance Curves - continued

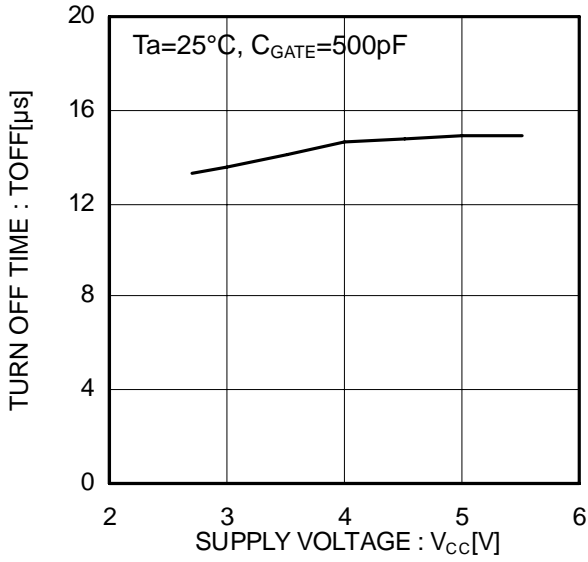

Figure 17. GATE Fall Time

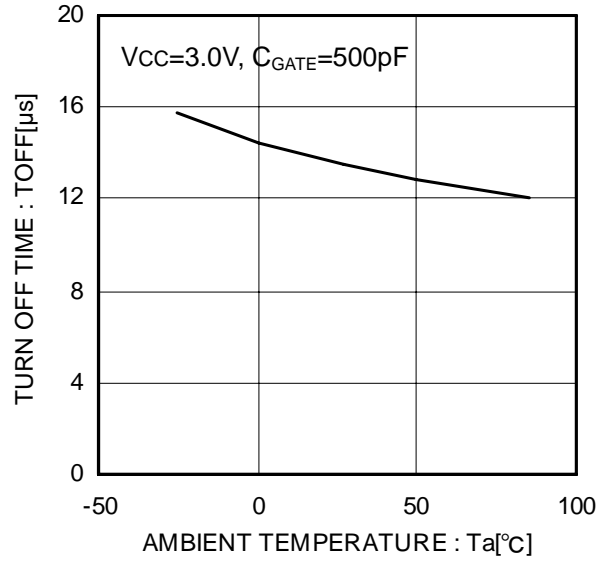

Figure 18. GATE Fall Time

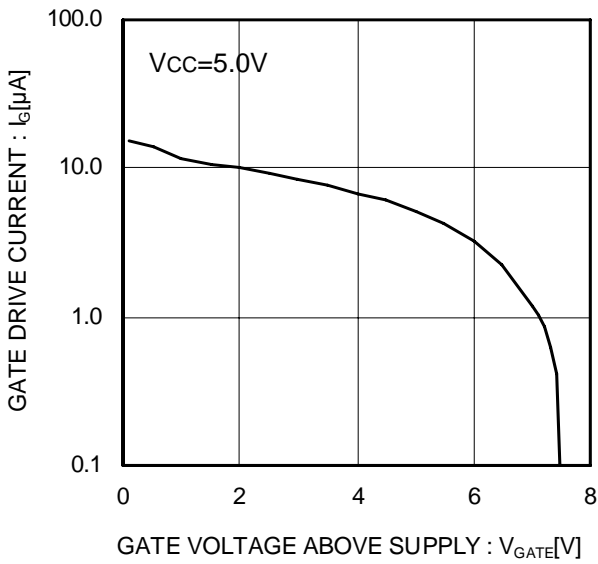

Figure 19. GATE Drive Current

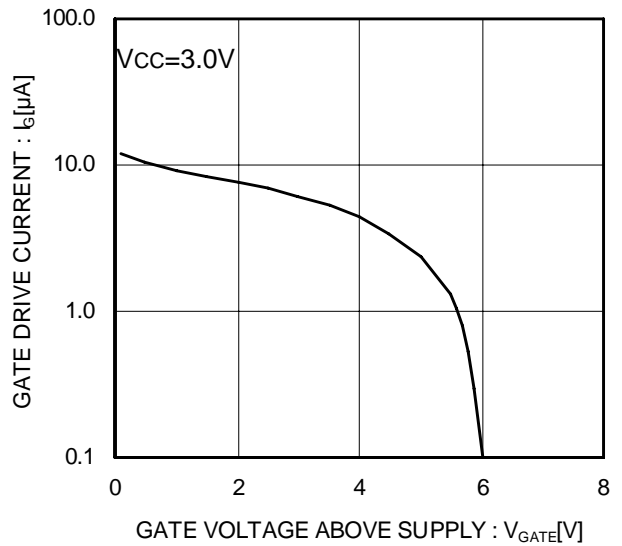

Figure 20. GATE Drive Current

Typical Wave Forms

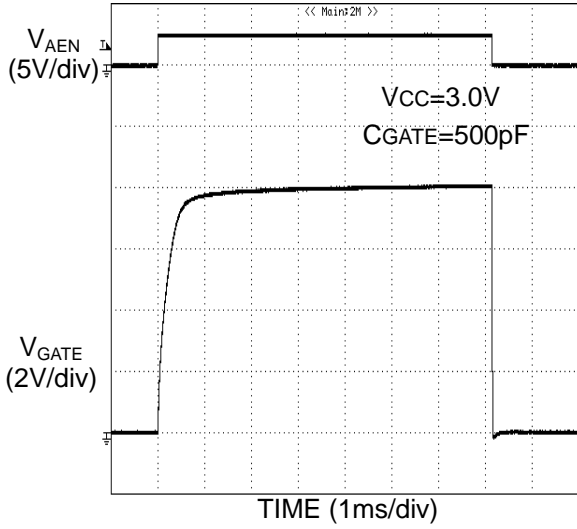

Figure 21. GATE Rise / Fall Characteristics

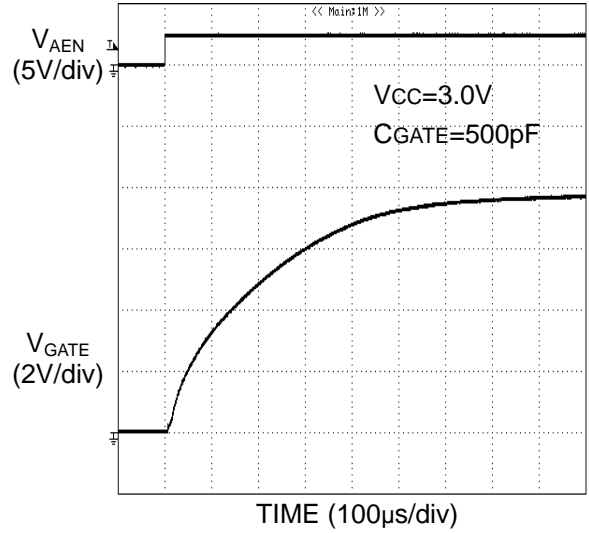

Figure 22. GATE Rise Characteristics

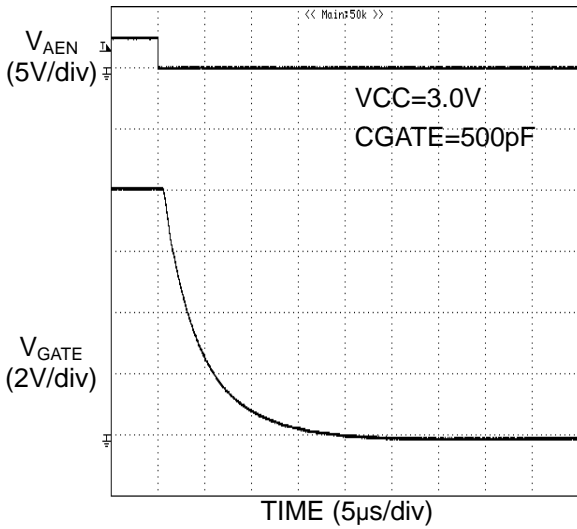

Figure 23. GATE Fall Characteristics

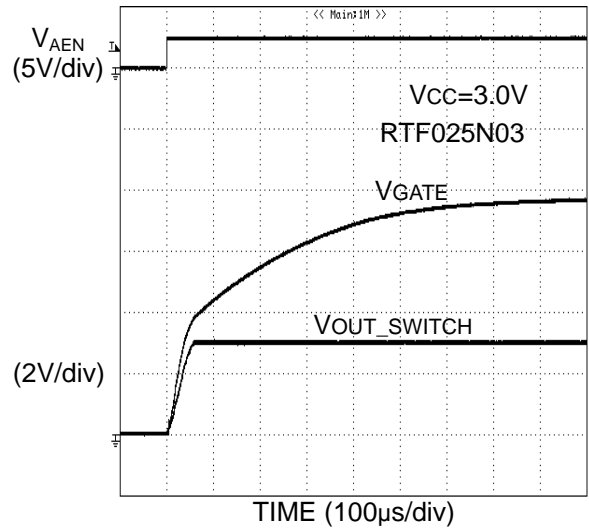

Figure 24. GATE Switch Rise Characteristics

Typical Wave Forms - continued

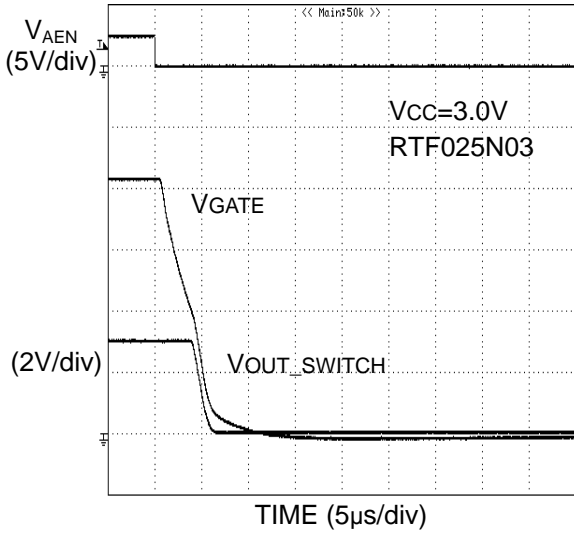

Figure 25. GATE Switch Fall Characteristics

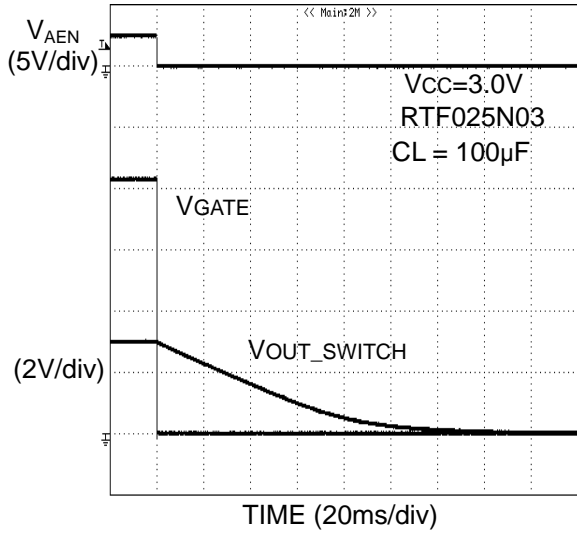

Figure 26. GATE Switch Fall Characteristics

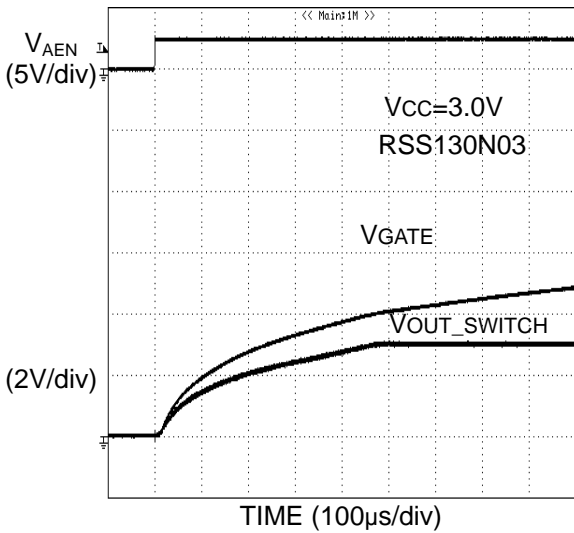

Figure 27. GATE Switch Rise Characteristics

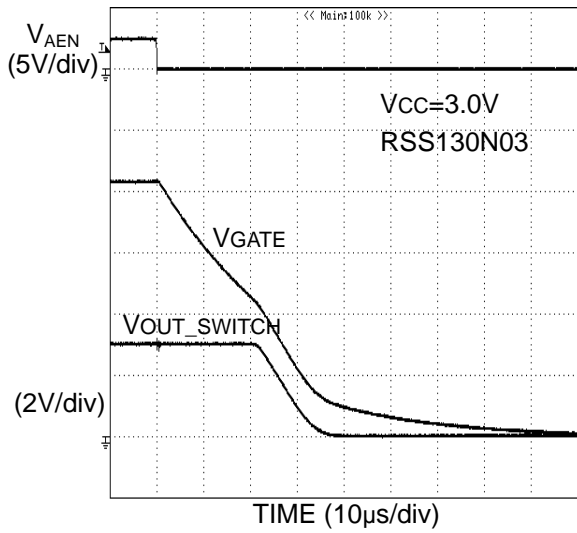

Figure 28. GATE Switch Fall Characteristics

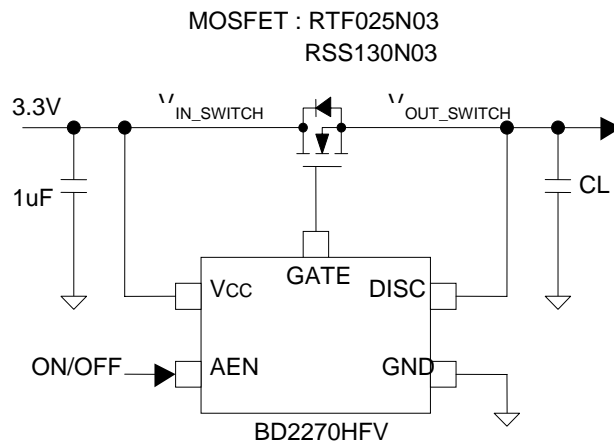

Figure 29. Switch Rise / Fall Characteristics Measurement Circuit Diagram

Application Circuit

1. Configuration of 3.3V load switch

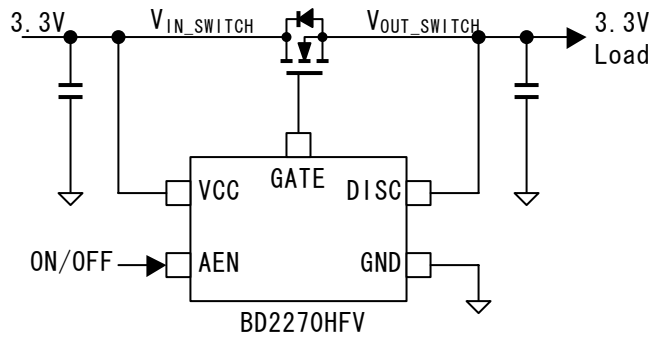

Figure 30. Configuration of 3.3V Load Switch

2. Configuration of 5V load switch

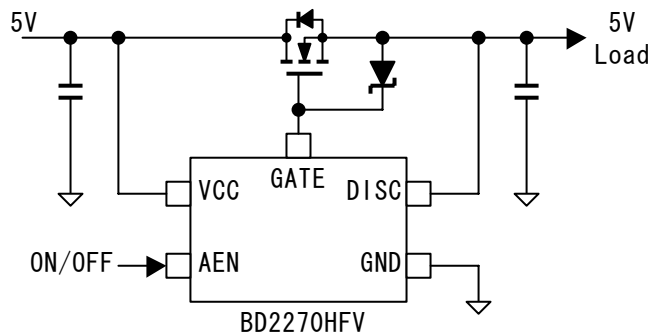

Figure 31. Configuration of 5V Load Switch

A 5V load switch can be configured like the 3.3V load switch. However, if the external N-channel MOSFET has low VGSS, clamp it with Zener diode and the like.

3. Configuration of low-voltage load switch

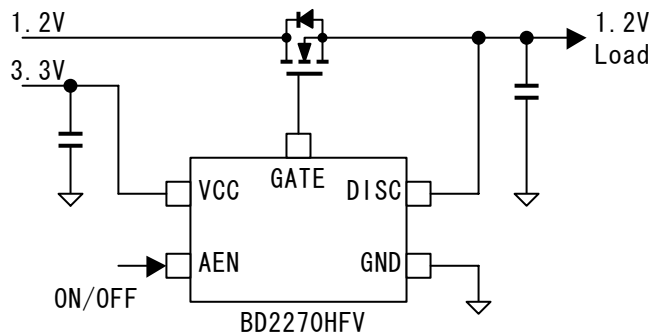

Figure 32. Configuration of Low-voltage Load Switch

Providing BD2270HFV drive power supply enables configuration of a low-voltage load switch.

4. Soft start configuration

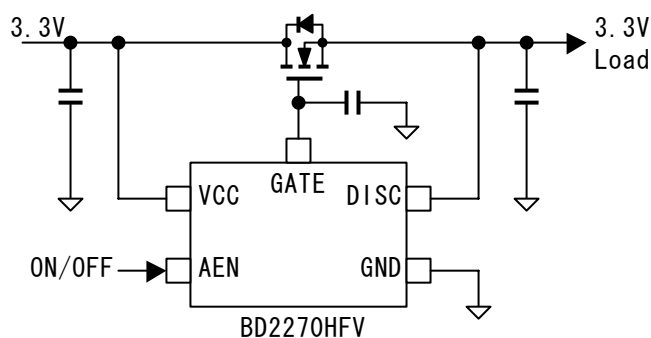

Figure 33. Soft Start Configuration

Connecting an external capacitor to the GATE terminal of the BD2270HFV makes it possible to lengthen the rise time of the N-channel MOSFET, thus achieving reduction of the inrush current to the large-capacity capacitor mounted on the load side.

Application Information

The system connection diagram shown here gives no guarantee to the operation of the application circuit.

When the recommended external circuit components are changed, be sure to consider adequate margins by taking into account external parts and/or IC's dispersion including not only static characteristics, but also transient characteristics.

Functional Description

The BD2270HFV is a driver IC that uses an N-channel MOSFET as a high side load switch. This IC incorporates the following functions.

1. GATE drive

The gate drive voltage of an N-channel MOSFET is generated by a built-in charge pump in the BD2270HFV. The built-in charge pump in the BD2270HFV generates a voltage three times as high as the power supply voltage at the GATE terminal. In addition, since this IC has a built-in capacitor for the charge pump, it needs no external parts.

The charge pump operates when the AEN is set to High. When the AEN is set to Low, the GATE terminal voltage is fixed to the GND level.

2. Output discharge circuit

The output discharge circuit is enabled when the AEN is set to Low. When the discharge circuit is activated, the 200Ω (Typ.) MOSFET switch located between the DISC terminal and the GND terminal turns ON. Connecting the DISC terminal and the source side (load side) of the N-channel MOSFET makes it possible to immediately discharge capacitive load.

3. Soft start function

When the AEN terminal input voltage reaches the High level, the built-in charge pump in the BD2270HFV charges the gate of the N-channel MOSFET. The turn-on time of the N-channel MOSFET is determined by the GATE capacity. In addition, connecting a capacitor to the GATE terminal makes it possible to lengthen the rise of turn-on time of the N-channel MOSFET, thus achieving reduction of the inrush current to a large capacitive load.

4. Analog control input terminal

The AEN input of the BD2270HFV is connected to the built-in hysteresis comparator. Consequently, even analog signals can control the BD2270HFV, thus facilitating the control of the switch ON-OFF sequence.

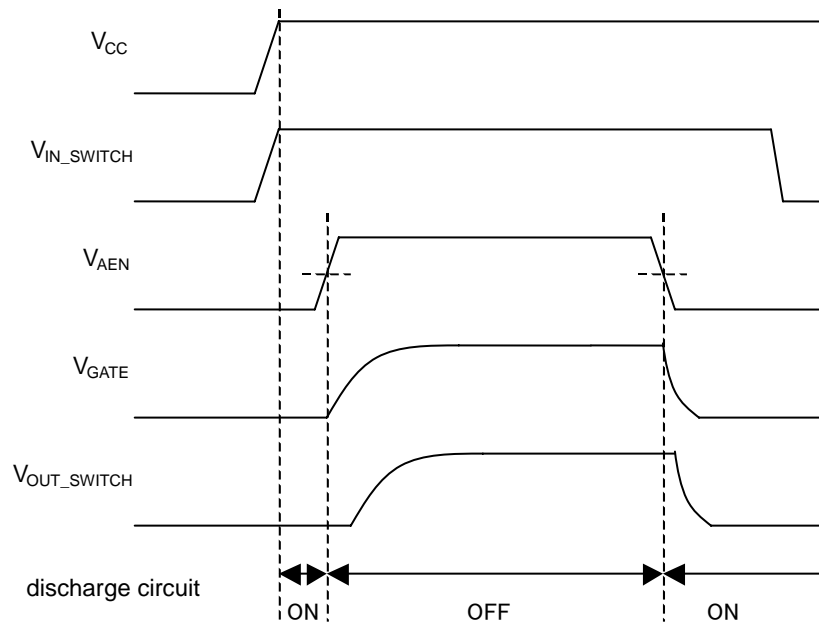
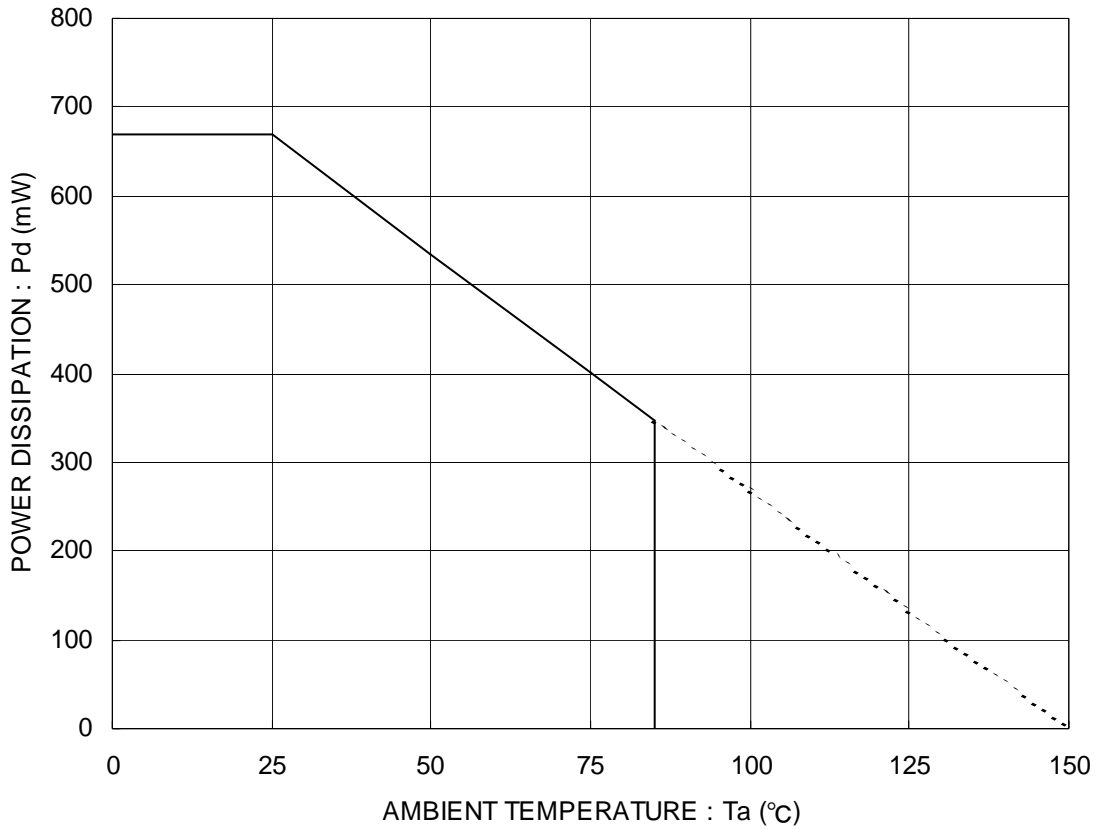

Figure 34. Operation Timing

* To turn ON the power supply (V_{CC} , V_{IN_SWITCH}), set the AEN to Low.

Power Dissipation

(HVSOF5)



Mounted on a 70 mm×70 mm×1.6 mm glass epoxy PCB
 Figure 35. Power dissipation curve (Pd-Ta Curve)

I/O Equivalent Circuit

Pin name	Pin No.	Equivalent circuit
AEN	3	
DISC	4	
GATE	5	

Operational Notes

(1) Absolute Maximum Ratings

Operating the IC over the absolute maximum ratings may damage the IC. The damage can either be a short circuit between pins or an open circuit between pins. Therefore, it is important to consider circuit protection measures, such as adding a fuse, in case the IC is operated over the absolute maximum ratings

(2) Recommended operating conditions

These conditions represent a range within which the expected characteristics of the IC can be approximately obtained. The electrical characteristics are guaranteed under the conditions of each parameter.

(3) Reverse connection of power supply

Connecting the power supply in reverse polarity can damage the IC. Take precautions against reverse polarity when connecting the power supply, such as mounting an external diode between the power supply and the IC's power supply terminals.

(4) Power supply line

Design the PCB layout pattern to provide low impedance ground and supply lines. Separate the ground and supply lines of the digital and analog blocks to prevent noise in the ground and supply lines of the digital block from affecting the analog block. Furthermore, connect a capacitor to ground at all power supply pins. Consider the effect of temperature and aging on the capacitance value when using electrolytic capacitors.

(5) Ground Voltage

The voltage of the ground pin must be the lowest voltage of all pins of the IC at all operating conditions. Ensure that no pins are at a voltage below the ground pin at any time, even during transient condition.

(6) Short between pins and mounting errors

Be careful when mounting the IC on printed circuit boards. The IC may be damaged if it is mounted in a wrong orientation or if pins are shorted together. Short circuit may be caused by conductive particles caught between the pins.

(7) Operation under strong electromagnetic field

Operating the IC in the presence of a strong electromagnetic field may cause the IC to malfunction.

(8) Testing on application boards

When testing the IC on an application board, connecting a capacitor directly to a low-impedance output pin may subject the IC to stress. Always discharge capacitors completely after each process or step. The IC's power supply should always be turned off completely before connecting or removing it from the test setup during the inspection process. To prevent damage from static discharge, ground the IC during assembly and use similar precautions during transport and storage.

(9) Regarding input pins of the IC

This monolithic IC contains P⁺ isolation and P substrate layers between adjacent elements in order to keep them isolated. P-N junctions are formed at the intersection of the P layers with the N layers of other elements, creating a parasitic diode or transistor. For example (refer to figure below):

When GND > Pin A and GND > Pin B, the P-N junction operates as a parasitic diode.

When GND > Pin B, the P-N junction operates as a parasitic transistor.

Parasitic diodes inevitably occur in the structure of the IC. The operation of parasitic diodes can result in mutual interference among circuits, operational faults, or physical damage. Therefore, conditions that cause these diodes to operate, such as applying a voltage lower than the GND voltage to an input pin (and thus to the P substrate) should be avoided.

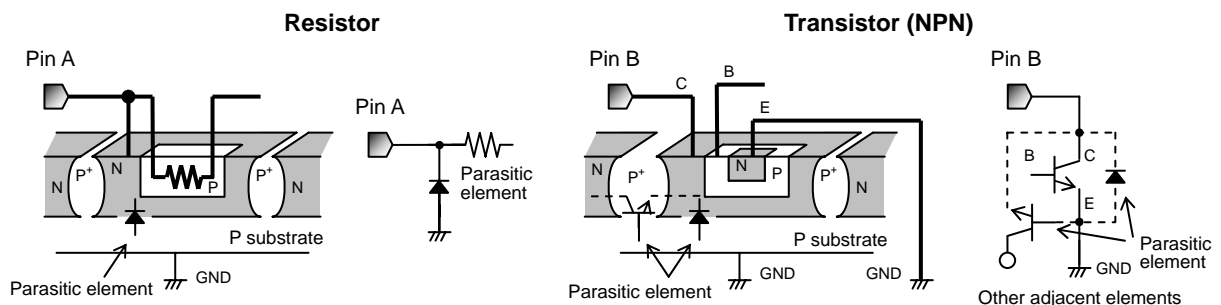

Example of monolithic IC structure

(10) GND wiring pattern

When using both small-signal and large-current GND traces, the two ground traces should be routed separately but connected to a single ground at the reference point of the application board to avoid fluctuations in the small-signal ground caused by large currents. Also ensure that the GND traces of external components do not cause variations on the GND voltage. The power supply and ground lines must be as short and thick as possible to reduce line impedance.

(11) External Capacitor

When using a ceramic capacitor, determine the dielectric constant considering the change of capacitance with temperature and the decrease in nominal capacitance due to DC bias and others.

(12) Thermal consideration

Use a thermal design that allows for a sufficient margin by taking into account the permissible power dissipation (Pd) in actual operating conditions. Consider Pc that does not exceed Pd in actual operating conditions ($P_c \geq P_d$).

Package Power dissipation : $P_d (W) = (T_{jmax} - T_a) / \theta_{ja}$

Power dissipation : $P_c (W) = (V_{cc} - V_o) \times I_o + V_{cc} \times I_b$

T_{jmax} : Maximum junction temperature=150°C, T_a : Peripheral temperature[°C],
 θ_{ja} : Thermal resistance of package-ambience[°C/W], P_d : Package Power dissipation [W],
 P_c : Power dissipation [W], V_{cc} : Input Voltage, V_o : Output Voltage, I_o : Load, I_b : Bias Current

Ordering Information

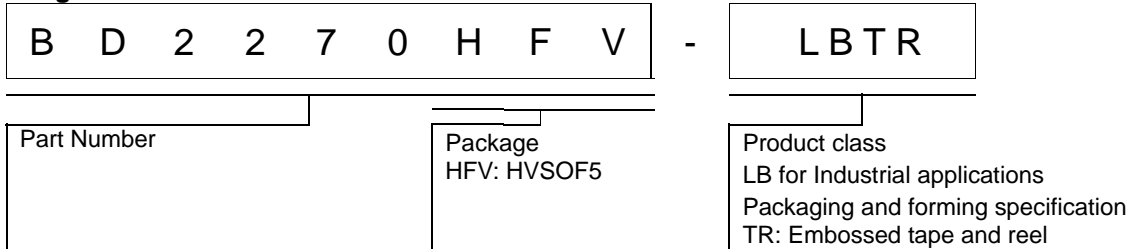

Marking Diagram

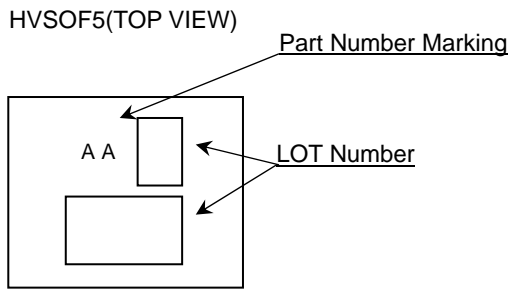

Part Number	Part Number Marking
BD2270HFV	AA

Physical Dimension Tape and Reel Information

Package Name	HVSOF5
--------------	--------

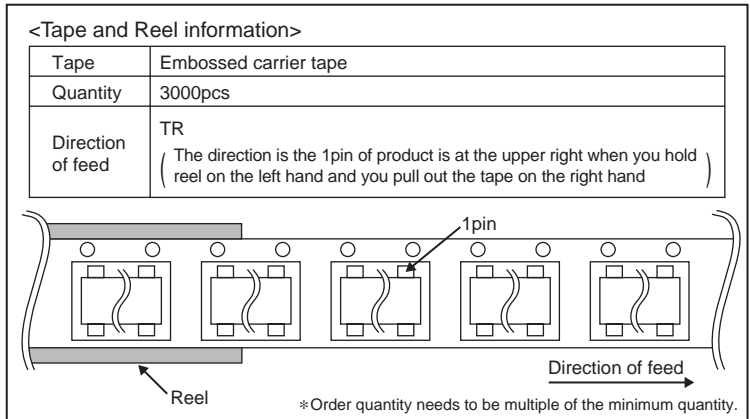
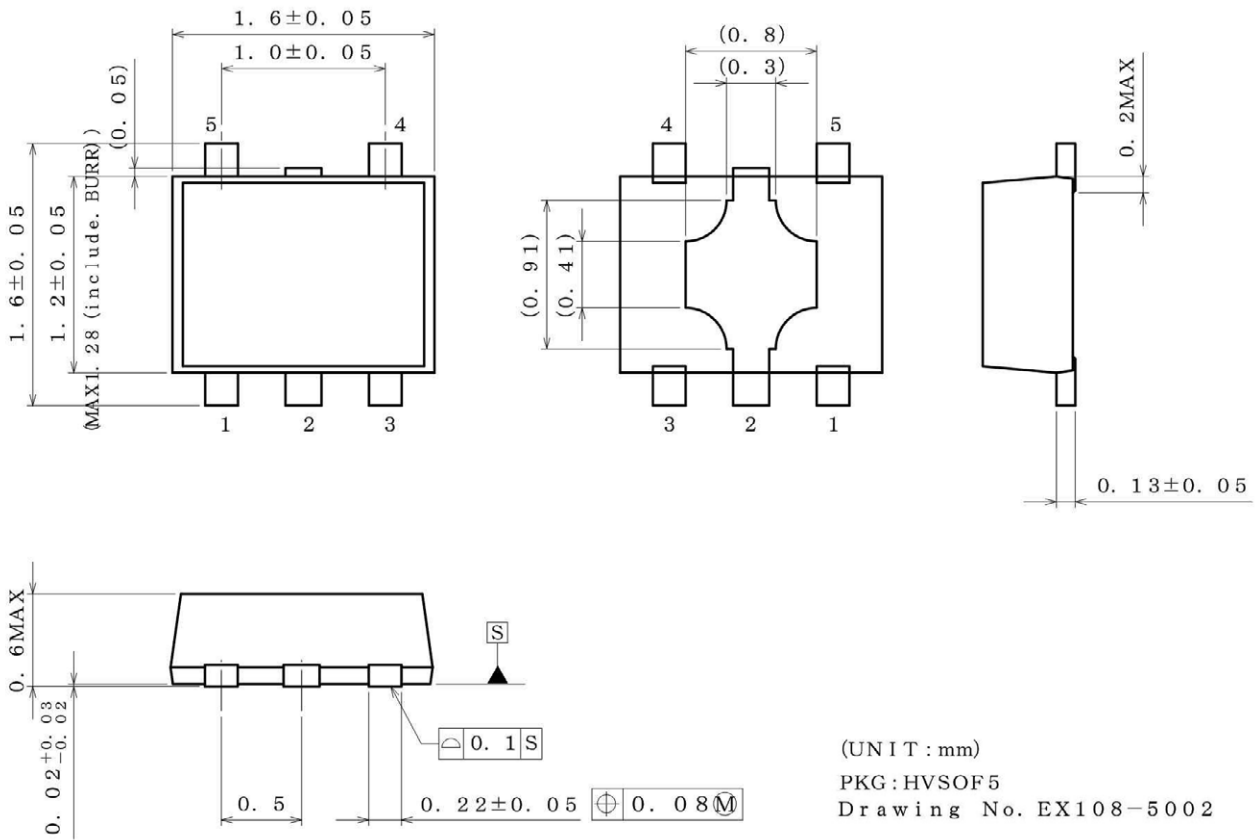

Revision History

Date	Revision	Changes
13.Mar.2013	001	New Release
21.Feb.2014	002	Delete sentence "and log life cycle" in General Description and Futures (page 1). Change "Industrial Applications" to "Industrial Equipment" in Applications (page 1). Applied new style ("title", "Ordering Information" and "Physical Dimension Tape and Reel Information").

Notice

Precaution on using ROHM Products

1. If you intend to use our Products in devices requiring extremely high reliability (such as medical equipment ^(Note 1), aircraft/spacecraft, nuclear power controllers, etc.) and whose malfunction or failure may cause loss of human life, bodily injury or serious damage to property ("Specific Applications"), please consult with the ROHM sales representative in advance. Unless otherwise agreed in writing by ROHM in advance, ROHM shall not be in any way responsible or liable for any damages, expenses or losses incurred by you or third parties arising from the use of any ROHM's Products for Specific Applications.

(Note1) Medical Equipment Classification of the Specific Applications

JAPAN	USA	EU	CHINA
CLASS III	CLASS III	CLASS II b	CLASS III
CLASS IV		CLASS III	

2. ROHM designs and manufactures its Products subject to strict quality control system. However, semiconductor products can fail or malfunction at a certain rate. Please be sure to implement, at your own responsibilities, adequate safety measures including but not limited to fail-safe design against the physical injury, damage to any property, which a failure or malfunction of our Products may cause. The following are examples of safety measures:
 - [a] Installation of protection circuits or other protective devices to improve system safety
 - [b] Installation of redundant circuits to reduce the impact of single or multiple circuit failure
3. Our Products are not designed under any special or extraordinary environments or conditions, as exemplified below. Accordingly, ROHM shall not be in any way responsible or liable for any damages, expenses or losses arising from the use of any ROHM's Products under any special or extraordinary environments or conditions. If you intend to use our Products under any special or extraordinary environments or conditions (as exemplified below), your independent verification and confirmation of product performance, reliability, etc, prior to use, must be necessary:
 - [a] Use of our Products in any types of liquid, including water, oils, chemicals, and organic solvents
 - [b] Use of our Products outdoors or in places where the Products are exposed to direct sunlight or dust
 - [c] Use of our Products in places where the Products are exposed to sea wind or corrosive gases, including Cl₂, H₂S, NH₃, SO₂, and NO₂
 - [d] Use of our Products in places where the Products are exposed to static electricity or electromagnetic waves
 - [e] Use of our Products in proximity to heat-producing components, plastic cords, or other flammable items
 - [f] Sealing or coating our Products with resin or other coating materials
 - [g] Use of our Products without cleaning residue of flux (even if you use no-clean type fluxes, cleaning residue of flux is recommended); or Washing our Products by using water or water-soluble cleaning agents for cleaning residue after soldering
 - [h] Use of the Products in places subject to dew condensation
4. The Products are not subject to radiation-proof design.
5. Please verify and confirm characteristics of the final or mounted products in using the Products.
6. In particular, if a transient load (a large amount of load applied in a short period of time, such as pulse. is applied, confirmation of performance characteristics after on-board mounting is strongly recommended. Avoid applying power exceeding normal rated power; exceeding the power rating under steady-state loading condition may negatively affect product performance and reliability.
7. De-rate Power Dissipation (Pd) depending on Ambient temperature (Ta). When used in sealed area, confirm the actual ambient temperature.
8. Confirm that operation temperature is within the specified range described in the product specification.
9. ROHM shall not be in any way responsible or liable for failure induced under deviant condition from what is defined in this document.

Precaution for Mounting / Circuit board design

1. When a highly active halogenous (chlorine, bromine, etc.) flux is used, the residue of flux may negatively affect product performance and reliability.
2. In principle, the reflow soldering method must be used; if flow soldering method is preferred, please consult with the ROHM representative in advance.

For details, please refer to ROHM Mounting specification

Precautions Regarding Application Examples and External Circuits

1. If change is made to the constant of an external circuit, please allow a sufficient margin considering variations of the characteristics of the Products and external components, including transient characteristics, as well as static characteristics.
2. You agree that application notes, reference designs, and associated data and information contained in this document are presented only as guidance for Products use. Therefore, in case you use such information, you are solely responsible for it and you must exercise your own independent verification and judgment in the use of such information contained in this document. ROHM shall not be in any way responsible or liable for any damages, expenses or losses incurred by you or third parties arising from the use of such information.

Precaution for Electrostatic

This Product is electrostatic sensitive product, which may be damaged due to electrostatic discharge. Please take proper caution in your manufacturing process and storage so that voltage exceeding the Products maximum rating will not be applied to Products. Please take special care under dry condition (e.g. Grounding of human body / equipment / solder iron, isolation from charged objects, setting of Ionizer, friction prevention and temperature / humidity control).

Precaution for Storage / Transportation

1. Product performance and soldered connections may deteriorate if the Products are stored in the places where:
 - [a] the Products are exposed to sea winds or corrosive gases, including Cl₂, H₂S, NH₃, SO₂, and NO₂
 - [b] the temperature or humidity exceeds those recommended by ROHM
 - [c] the Products are exposed to direct sunshine or condensation
 - [d] the Products are exposed to high Electrostatic
2. Even under ROHM recommended storage condition, solderability of products out of recommended storage time period may be degraded. It is strongly recommended to confirm solderability before using Products of which storage time is exceeding the recommended storage time period.
3. Store / transport cartons in the correct direction, which is indicated on a carton with a symbol. Otherwise bent leads may occur due to excessive stress applied when dropping of a carton.
4. Use Products within the specified time after opening a humidity barrier bag. Baking is required before using Products of which storage time is exceeding the recommended storage time period.

Precaution for Product Label

QR code printed on ROHM Products label is for ROHM's internal use only.

Precaution for Disposition

When disposing Products please dispose them properly using an authorized industry waste company.

Precaution for Foreign Exchange and Foreign Trade act

Since our Products might fall under controlled goods prescribed by the applicable foreign exchange and foreign trade act, please consult with ROHM representative in case of export.

Precaution Regarding Intellectual Property Rights

1. All information and data including but not limited to application example contained in this document is for reference only. ROHM does not warrant that foregoing information or data will not infringe any intellectual property rights or any other rights of any third party regarding such information or data. ROHM shall not be in any way responsible or liable for infringement of any intellectual property rights or other damages arising from use of such information or data.:
2. No license, expressly or implied, is granted hereby under any intellectual property rights or other rights of ROHM or any third parties with respect to the information contained in this document.

Other Precaution



1. This document may not be reprinted or reproduced, in whole or in part, without prior written consent of ROHM.
2. The Products may not be disassembled, converted, modified, reproduced or otherwise changed without prior written consent of ROHM.
3. In no event shall you use in any way whatsoever the Products and the related technical information contained in the Products or this document for any military purposes, including but not limited to, the development of mass-destruction weapons.
4. The proper names of companies or products described in this document are trademarks or registered trademarks of ROHM, its affiliated companies or third parties.

General Precaution

1. Before you use our Products, you are requested to carefully read this document and fully understand its contents. ROHM shall not be in any way responsible or liable for failure, malfunction or accident arising from the use of any ROHM's Products against warning, caution or note contained in this document.
2. All information contained in this document is current as of the issuing date and subject to change without any prior notice. Before purchasing or using ROHM's Products, please confirm the latest information with a ROHM sales representative.
3. The information contained in this document is provided on an "as is" basis and ROHM does not warrant that all information contained in this document is accurate and/or error-free. ROHM shall not be in any way responsible or liable for any damages, expenses or losses incurred by you or third parties resulting from inaccuracy or errors of or concerning such information.

Looking for pricing, stock, or lifecycle information?

Click below to explore more details on WIN SOURCE:

-  [View BD2270HFV-LBTR on WIN SOURCE](#)
-  [Rohm Semiconductor](#) Information

Optimize Your Supply Chain with WIN SOURCE Solutions

-  Global Sourcing Solution
-  Obsolete Management
-  Cost Control Management
-  Shortage Management
-  Alternative Solution
-  Excess Inventory Management