



**THE DATASHEET OF
MAX25301BATB/V+**



MAX25301A/MAX25301B

1A Automotive Low-Noise LDO Linear Regulator

General Description

The MAX25301A/B are low-noise automotive linear regulators that deliver up to 1A of output current with only 7 μ V_{RMS} of output noise from 10Hz to 100kHz.

These regulators maintain $\pm 1\%$ output accuracy over a wide input-voltage range, requiring only 100mV of input-to-output headroom at full load. The 1200 μ A no-load supply current is independent of dropout voltage.

The MAX25301A has nine pin-selectable output voltages: 1.2V, 1.5V, 1.8V, 2.5V, 3.0V, 3.1V, 3.3V, 4.0V, and 5V. The MAX25301B output voltage can be adjusted to a value in the range of 0.6V to 5.3V using two external resistors. The MAX25301B also includes an active-high POK signal for trouble-free load startup.

All versions include a programmable output soft-start rate as well as output-overcurrent and thermal-overload protection.

The MAX25301A/B are offered in a 10-pin TDFN (3mm x 3mm) package.

Applications

- Automotive Electronics
- Audio Systems
- High-Resolution Data Acquisition Systems

Benefits and Features

- 1.7V to 5.5V Input Voltage Range
- 0.6V to 5.3V Programmable Output Voltage
- 7 μ V_{RMS} Output Noise, 10Hz to 100kHz
- 1200 μ A Operating Supply Current
- 70dB PSRR at 10kHz
- 1A Maximum Output Current
- $\pm 1\%$ DC Accuracy Over Load, Line, and Temperature
- 100mV Maximum Dropout at 1A Load
- <1 μ A Shutdown Supply Current
- Stable with 4 μ F(min) Output Capacitance
- Programmable Soft-Start Rate
- Overcurrent and Overtemperature Protection
- Output-to-Input Reverse-Current Protection
- Power-OK Output
- 3mm x 3mm 10-pin TDFN Package
- AEC-Q100
- -40°C to 125°C Operating Temperature

Ordering Information appears at end of datasheet.

Typical Operating Circuits

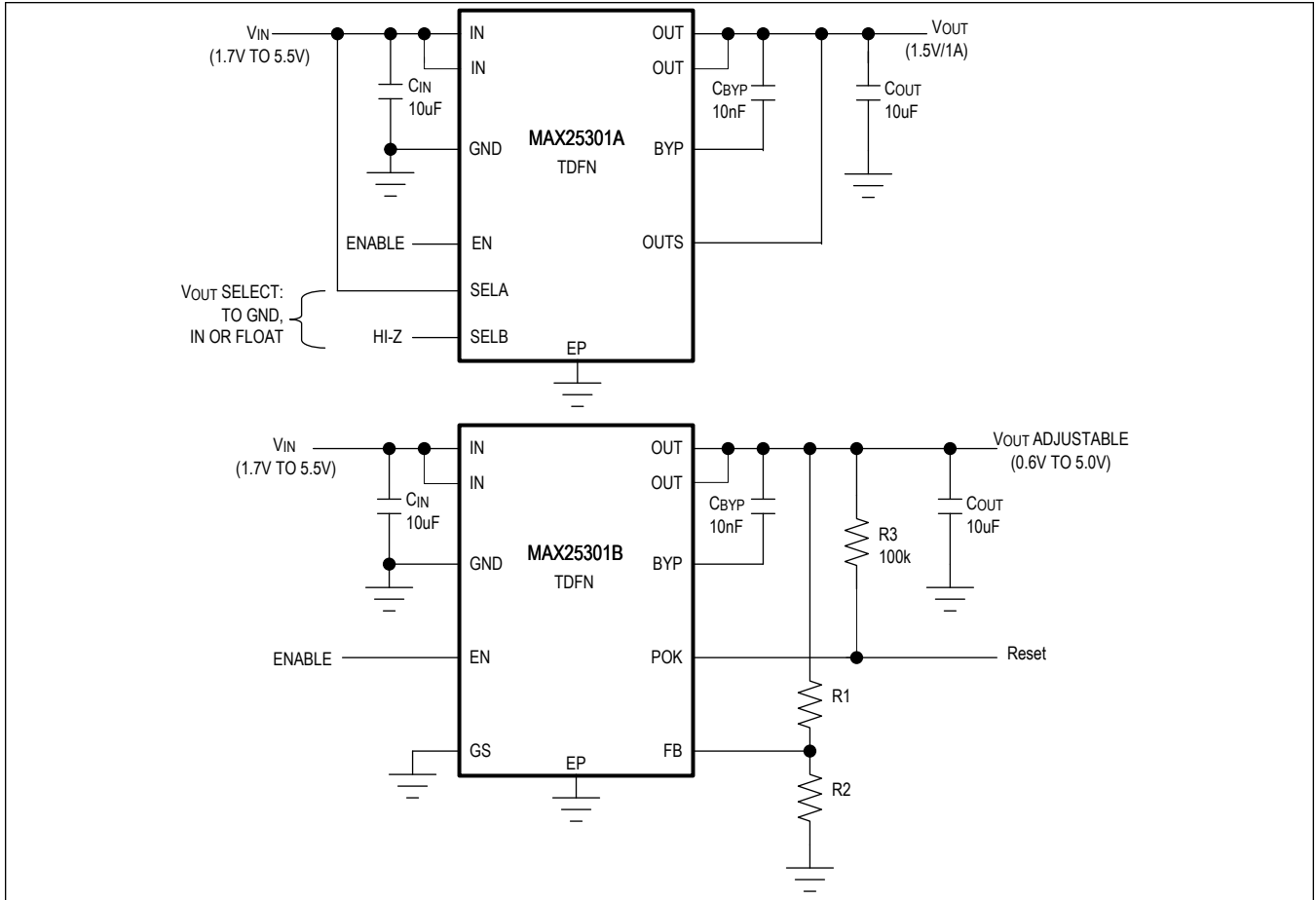

TABLE OF CONTENTS

General Description	1
Applications	1
Benefits and Features	1
Typical Operating Circuits	2
Absolute Maximum Ratings	5
Package Information	5
TDFN	5
Electrical Characteristics	5
Typical Operating Characteristics	7
Pin Configurations	8
MAX25301A	8
MAX25301B	9
Pin Description	9
Functional Diagrams	11
Simplified Functional Diagram	11
Detailed Description	12
Enable (EN)	12
Bypass (BYP)	12
Protection Features	12
Output Voltage Configuration (MAX25301A)	12
Output Voltage Configuration (MAX25301B)	13
Power-OK (MAX25301B)	13
Input Capacitor	13
Output Capacitor	13
Thermal Considerations	13
Typical Application Circuits	14
Typical Application Circuits	14
Ordering Information	14
Revision History	15

LIST OF TABLES

Table 1. MAX25301A Output Configuration 13

Absolute Maximum Ratings

IN, EN, POK, RSEL, BYP to GND	-0.3V to +6V	Operating Temperature Range	-40°C to +125°C
FB, OUTS, SELA, SELB to GND	-0.3V to +6V	Maximum Junction Temperature	+150°C
OUT to GND	-0.3V to IN + 0.3V	Storage Temperature Range	-65°C to +150°C
Output Short-Circuit Duration	Continuous	Lead Temperature (Soldering, 10 seconds)	+300°C
Continuous Power Dissipation (TA = +70°C)		Soldering Temperature (reflow)	+260°C
TDFN (derate 24.4mW/°C above 70°C)	1951mW		

Stresses beyond those listed under "Absolute Maximum Ratings" may cause permanent damage to the device. These are stress ratings only, and functional operation of the device at these or any other conditions beyond those indicated in the operational sections of the specifications is not implied. Exposure to absolute maximum rating conditions for extended periods may affect device reliability.

Package Information

TDFN

Package Code	T1033+1C
Outline Number	21-0137
Land Pattern Number	90-0003
Thermal Resistance, Single-Layer Board:	
Junction to Ambient (θ_{JA})	54°C/W
Junction to Case (θ_{JC})	9°C/W
Thermal Resistance, Four-Layer Board:	
Junction to Ambient (θ_{JA})	41°C/W
Junction to Case (θ_{JC})	9°C/W

For the latest package outline information and land patterns (footprints), go to www.maximintegrated.com/packages. Note that a "+", "#", or "-" in the package code indicates RoHS status only. Package drawings may show a different suffix character, but the drawing pertains to the package regardless of RoHS status.

Package thermal resistances were obtained using the method described in JEDEC specification JESD51-7, using a four-layer board. For detailed information on package thermal considerations, refer to www.maximintegrated.com/thermal-tutorial.

Electrical Characteristics

($V_{IN} = 3.6V$, $T_J = -40^\circ C$ to $+125^\circ C$, $C_{BYP} = 0.047\mu F$, $C_{IN} = 10\mu F$, $C_{OUT} = 10\mu F$, $I_{OUT} = 100mA$, unless otherwise specified. Note 1.)

PARAMETER	SYMBOL	CONDITIONS	MIN	TYP	MAX	UNITS
Input Voltage Range	V_{IN}	Guaranteed by output accuracy	1.7		5.5	V
Input Undervoltage Lockout	V_{IN_UVLO}	V_{IN} rising, 100mV hysteresis	1.5	1.6	1.7	V
Output Voltage Range	V_{OUT}	$V_{IN} > V_{OUT} + 0.1V$	0.6		5.3	V
Output Capacitance	C_{OUT}	For stability and proper operation	4	10		μF
Supply Current	I_Q	$I_{OUT} = 0mA$		1200	2000	μA
	$I_{SHUTDOWN}$	$V_{EN} = 0V$	$T_J = +25^\circ C$	0.01	0.1	
			$T_J = +125^\circ C$	0.1		μA
Output Accuracy (MAX25301A Only)	ACC25301A	I_{OUT} from 0.1mA to 1A, V_{IN} from $V_{OUT} + 0.3V$ to 5.5V, $V_{IN} > 1.7V$	-1.0		1.0	%
Output Accuracy (MAX25301B Only)	ACC25301B	I_{OUT} from 0.1mA to 1A, V_{IN} from $V_{OUT} + 0.3V$ to 5.5V, $V_{IN} > 1.7V$	0.594	0.6	0.606	V
Load Regulation		I_{OUT} from 0.1mA to 1A		0.02		%/V
Load Transient		$I_{OUT} = 50mA$ to 1A to 50mA, $t_{RISE} = t_{FALL} = 1\mu s$		50		mV

Electrical Characteristics (continued)(V_{IN} = 3.6V, T_J = -40°C to +125°C, C_{BYP} = 0.047μF, C_{IN} = 10μF, C_{OUT} = 10μF, I_{OUT} = 100mA, unless otherwise specified. Note 1.)

PARAMETER	SYMBOL	CONDITIONS		MIN	TYP	MAX	UNITS
Line Regulation		V _{IN} from V _{OUT} + 0.3V to 5.5V, V _{IN} > 1.7V			0.05		%/V
Line Transient		V _{IN} = 4V to 5V to 4V, I _{OUT} = 1A, t _{RISE} = t _{FALL} = 5μs			3		mV
Dropout Voltage (Note 2)		I _{OUT} = 1A	V _{IN} = 3.6V		50	100	mV
			V _{IN} = 2.5V (Note 3)		80	160	
			V _{IN} = 1.7V		150	300	
Current Limit		V _{OUT} = 95% of regulation		1.15	1.4	1.6	A
Output Noise		I _{OUT} = 100mA, f = 10Hz to 100kHz	C _{BYP} = 47nF		7		μV _{RMS}
Power Supply Rejection Ratio	PSRR	I _{OUT} = 100mA	f = 1kHz		70		dB
			f = 10kHz		70		
			f = 100kHz		60		
			f = 1MHz		40		
BYP Capacitor Range	C _{BYP}	Regulator remains stable		0.001		0.1	μF
BYP Soft-Start Current		From BYP to GND during startup			50		μA
EN Input Threshold		V _{IN} from 1.7V to 5.5V	EN rising		0.8	1.2	V
			EN falling	0.4	0.7		
EN Input Leakage Current		V _{EN} from 1.7V to 5.5V	T _J = +25°C	-1	0.001	+1	μA
			T _J = +125°C		0.01		
POK Threshold (MAX25301B Only)		V _{OUT} when $\overline{\text{POK}}$ switches	V _{OUT} rising	88	91	94	%
			V _{OUT} falling		88		
POK Voltage, Low (MAX25301B Only)		I _{POK} = 1mA			10	100	mV
POK Leakage Current (MAX25301B Only)		V _{POK} = 5.5V	T _J = +25°C	-0.1	0.001	+0.1	μA
			T _J = +125°C		0.01		
SELA/B Input Resistance (MAX25301A Only)	R _{INSELA/B}	When shorted to GND or IN				500	Ω
		When Hi-Z		1			MΩ
SELA/B Input Capacitance (MAX25301A Only)	C _{INSELA/B}	When Hi-Z				10	pF
Input Reverse-Current Threshold		V _{OUT} = 3.6V, when V _{IN} falls to 0V			400		mA
Thermal Shutdown Threshold		T _J when output turns on/off	T _J rising		165		°C
			T _J falling		150		

Note 1: Limits over the specified operating temperature and supply voltage range are guaranteed by design and characterization, and production tested at room temperature only.

Note 2: Dropout voltage is defined as (V_{IN} - V_{OUT}), when V_{IN} = V_{OUT(NOMINAL)} - 0.1V. For V_{OUT(NOMINAL)} less than 1.7V, dropout voltage is not guaranteed.

Note 3: Guaranteed by design and characterization.

Typical Operating Characteristics

(MAX25301B, $V_{IN} = 5.0V$, $V_{OUT} = 3.3V$, $T_A = 25^\circ C$, $C_{IN} = 10\mu F$, $C_{OUT} = 10\mu F$, unless otherwise noted.)

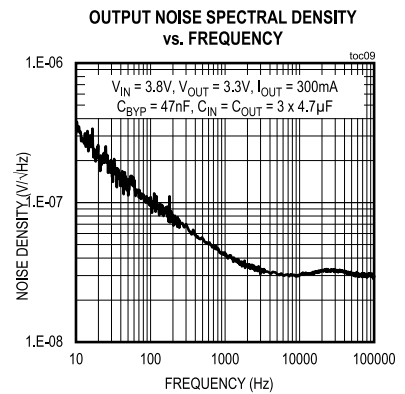
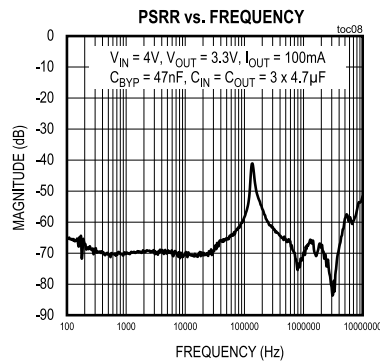
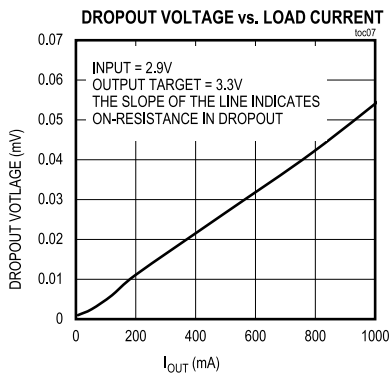
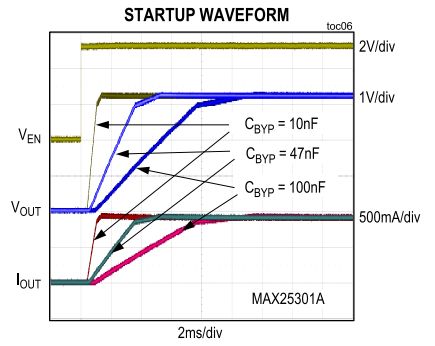
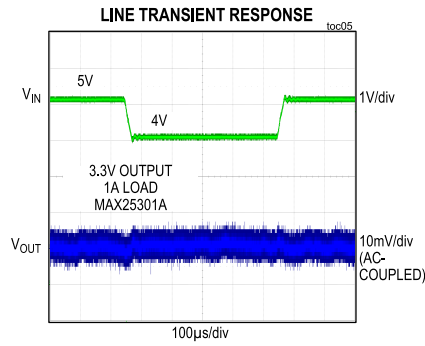
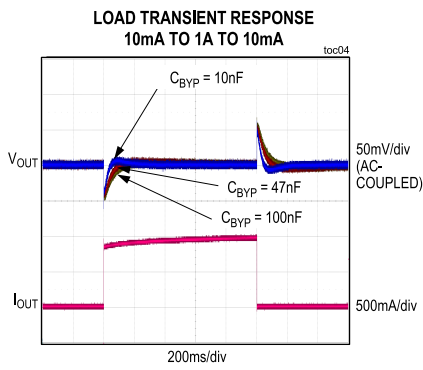
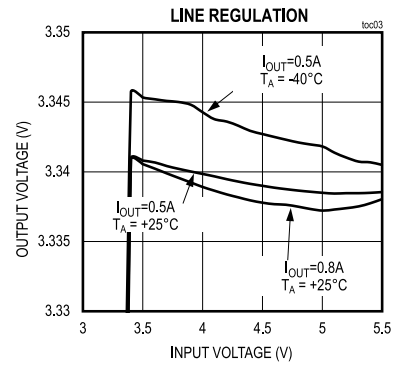
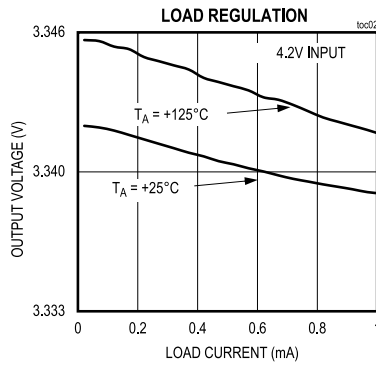
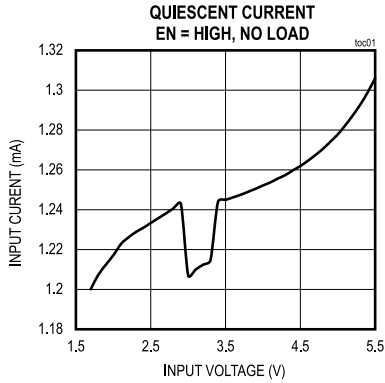

Pin Configurations

MAX25301A

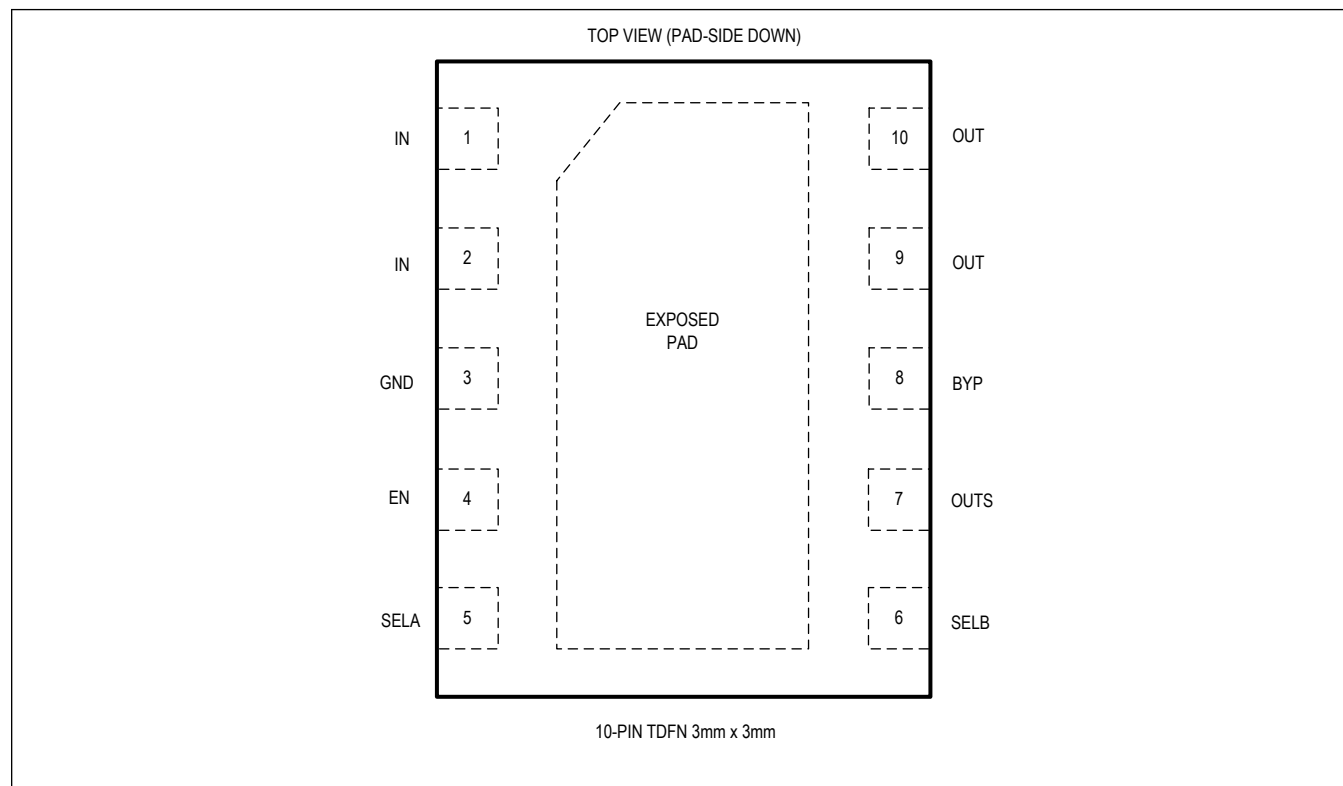

MAX25301B

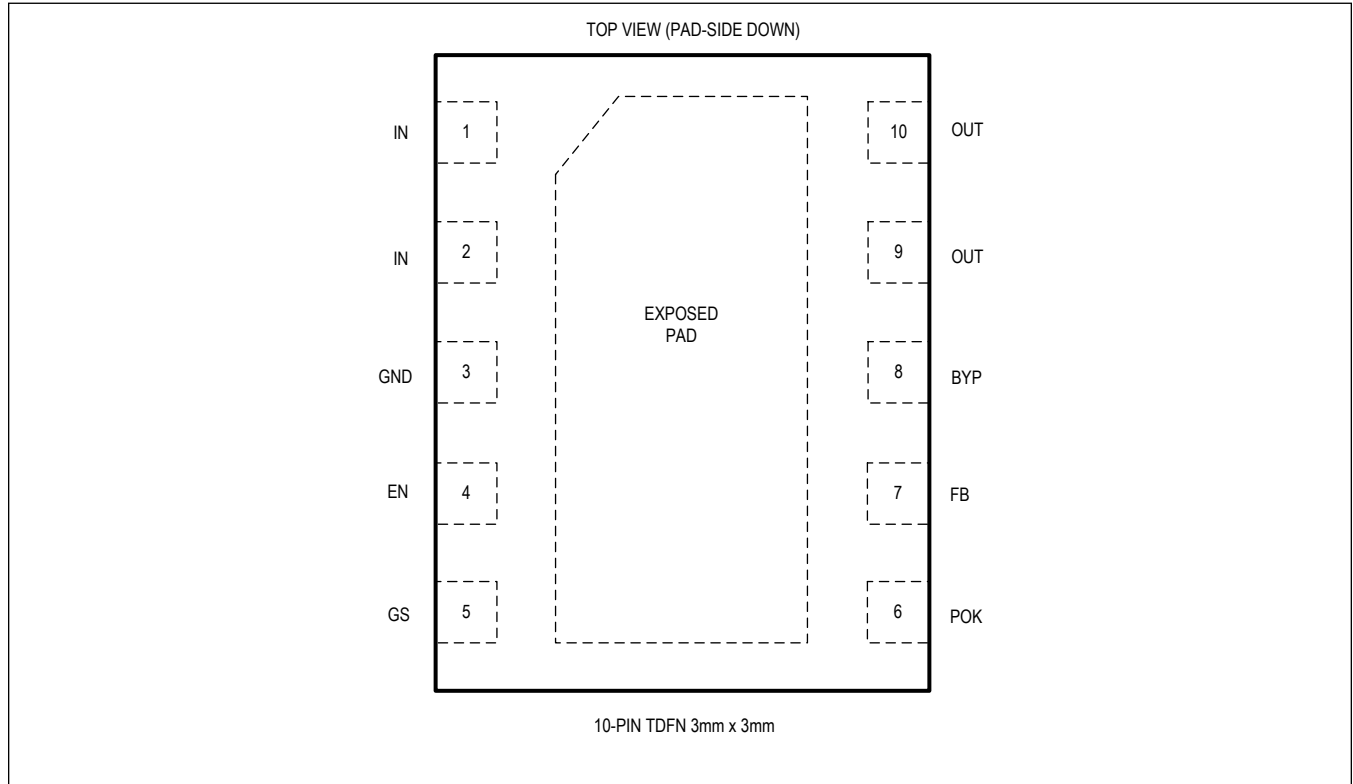

Pin Description

PIN		NAME	FUNCTION
MAX25301A	MAX25301B		
1, 2	1, 2	IN	Regulator Supply Input. Connect to a voltage between 1.7V and 5.5V and bypass with a 10µF capacitor from IN to GND.
3	3	GND	Regulator Ground. Connect IN and OUT bypass capacitor GND connections to this pin for best performance.
4	4	EN	Enable Input. Connect this pin to a logic signal to enable (V_{EN} high) or disable (V_{EN} low) the regulator output. Connect to IN to keep the output enabled whenever a valid supply voltage is present.
5	---	SELA	Select Input A. Connect to GND, IN, or leave unconnected to select the output voltage. This pin is read only at startup.
---	5	GS	Ground Sense. Connect GS to GND.
6	---	SELB	Select Input B. Connect to GND, IN, or leave unconnected to select the output voltage. This pin is read only at startup.
---	6	POK	Active-High Power-OK Output. Connect a pullup resistor from this pin to a supply to create a reset signal that goes high after the regulator output has reached its regulation voltage.
7	---	OUTS	Output Voltage Sense Input. Connect to the load at a point where accurate regulation is required to eliminate resistive metal drops.

Pin Description (continued)

PIN		NAME	FUNCTION
MAX25301A	MAX25301B		
---	7	FB	Feedback Divider Input. Connect a resistor-divider string from OUT to GND with the midpoint tied to this pin to set the output voltage. In Typical Application Circuits , $V_{OUT} = 0.6V \times (1 + R1/R2)$.
8	8	BYP	Bypass Capacitor Input. Connect a capacitor with a value from 0.001 μ F to 0.1 μ F between OUT and BYP to reduce output noise and set the regulator soft-start rate.
9, 10	9, 10	OUT	Regulator Output. Sources up to 1A at the output regulation voltage. Bypass with a 10 μ F (4 μ F minimum including voltage derating) low-ESR (<0.03 Ω) capacitor to GND.
EP	EP	EP	Exposed Pad (TDFN only). Connect the exposed pad to a ground plane with low thermal resistance to ambient to provide the best heat sinking.

Functional Diagrams

Simplified Functional Diagram

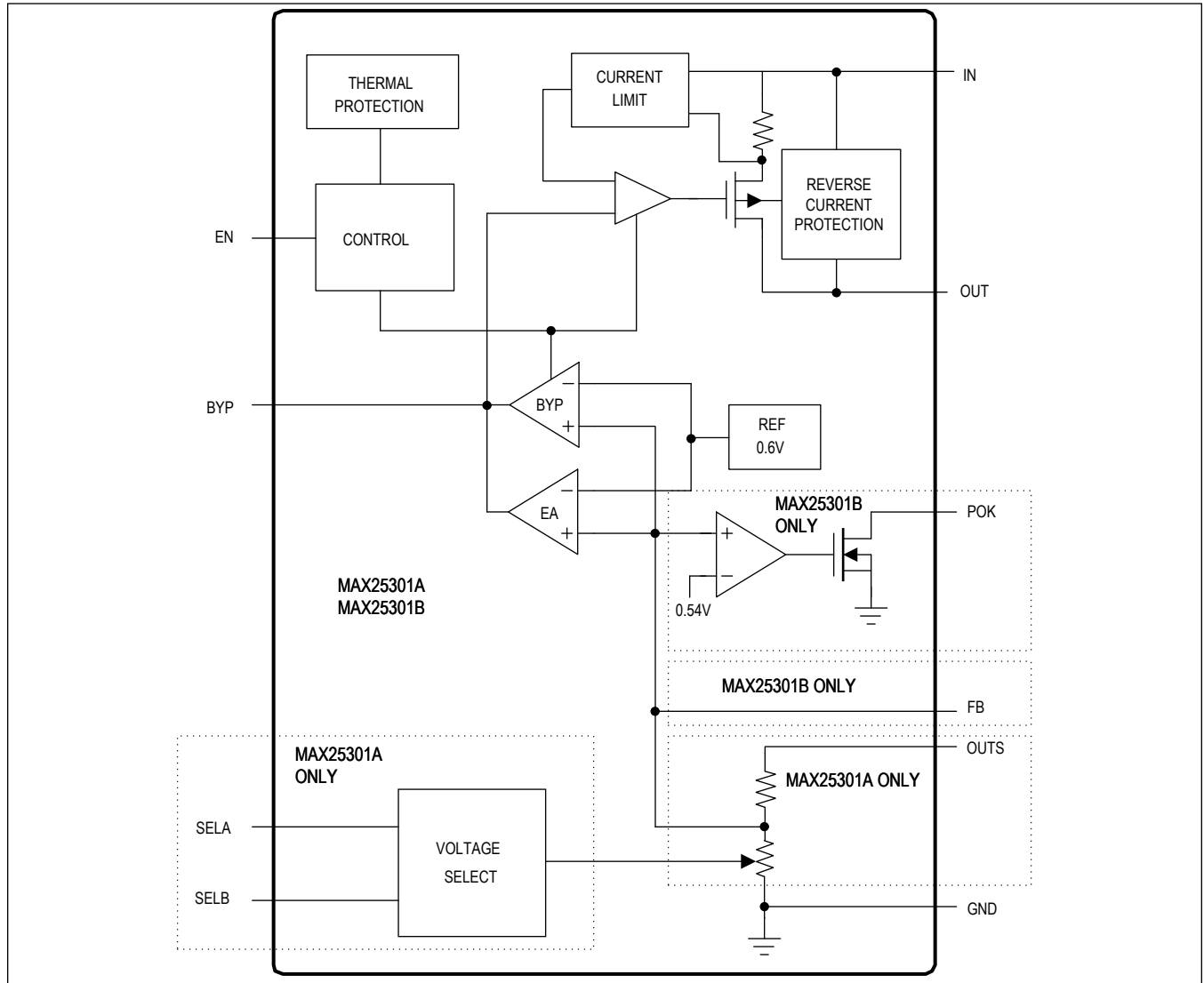

Detailed Description

The MAX25301A/B low-noise linear regulators deliver up to 1A of output current with only $7\mu\text{V}_{\text{RMS}}$ of output noise in a 10Hz to 100kHz bandwidth. These regulators maintain their output voltage over a wide input range, requiring only 100mV of input-to-output headroom at full load.

The MAX25301A/B maintain a low 1200 μA typical supply current, independent of the load current and dropout voltage. The regulator control circuitry includes a programmable soft-start circuit, short-circuit, reverse input current, and thermal-overload protection. Other features include an enable input and power-OK (POK) output (MAX25301B only). See [Simplified Functional Diagram](#).

Enable (EN)

The MAX25301A/B include an enable input (EN). Pull EN low to shut down the output, or drive EN high to enable the output. If a separate shutdown signal is not available, connect EN to IN.

Bypass (BYP)

The capacitor connected from BYP to OUT filters the noise of the reference, feedback resistors, and regulator input stage, and provides a high-speed feedback path for improved transient response. A 0.01 μF capacitor rolls off input noise at approximately 32Hz.

The slew rate of the output voltage during startup is also determined by the BYP capacitor. A 0.01 μF capacitor sets the slew rate to 5V/ms. This startup rate results in a 50mA slew current drawn from the input at startup to charge the 10 μF output capacitance.

The BYP capacitor value can be adjusted from 0.001 μF to 0.1 μF to change the startup slew rate according to the following formula:

$$\text{StartupSlewRate} = (5\text{V} / \text{ms}) \times (0.01 \mu\text{F} / C_{\text{BYP}})$$

where C_{BYP} is in μF .

Note that this slew rate applies only at startup. Recovery from a short-circuit will occur at a slew rate approximately 500 times slower.

Also note that, being a low-frequency filter node, BYP is sensitive to leakage. BYP leakage currents above 10nA cause measurable inaccuracy at the output and should be avoided.

Protection Features

The MAX25301A/B are fully protected from an output short circuit by a current-limiting and thermal-overload circuit. If the output is shorted to GND, the output current is limited to 1.4A (typ). Under these conditions, the part quickly heats up. When the junction temperature reaches 165°C, a thermal limit circuit shuts off the output device. When the junction cools to 150°C, the output turns back on in an attempt to re-establish regulation. While the fault persists, the output current cycles on and off as the junction temperature slews between 150°C and 165°C.

The MAX25301A/B are also protected against reverse current when the output voltage is higher than the input. In the event that extra output capacitance is used at the output, a power-down transient at the input would normally cause a large reverse current through a conventional regulator. The MAX25301A/B include a reverse-voltage detector that trips when IN drops 10mV below OUT, shutting off the regulator and opening the pMOS body diode connection, preventing any reverse current. Once the reverse voltage is removed, the output will start up again.

Output Voltage Configuration (MAX25301A)

The MAX25301A output can be set to one of nine voltages by shorting or opening the SELA and SELB inputs, as shown in [Table 1](#). SELA and SELB should be connected to GND, IN, or left unconnected. Alternatively, they may be driven high, low, or open with external logic. However, the states of SELA and SELB are sampled only at startup. The regulation voltage can be set to a different level by cycling EN or IN momentarily to GND.

Table 1. MAX25301A Output Configuration

V _{OUT} (V)	SELA STATE	SELB STATE
1.2	Unconnected	IN
1.5	IN	Unconnected
1.8	Unconnected	GND
2.5	Unconnected	Unconnected
3.0	GND	GND
3.1	GND	IN
3.3	GND	Unconnected
4.0	IN	GND
5.0	IN	IN

Output Voltage Configuration (MAX25301B)

The MAX25301B uses external feedback resistors to set the output regulation voltage as shown in the Typical Operating Circuit. The output can be set from 0.6V to 5.3V. Set the lower feedback resistor R2 to 300kΩ or less to minimize FB input bias current error. Then calculate the value of the upper feedback resistor R1 as follows:

$$R1 = R2 \times \left(\frac{V_{OUT}}{V_{FB}} - 1 \right)$$

where V_{FB} is the feedback regulation voltage of 0.6V. To set the output voltage to 2.5V, for example, R1 should be as follows:

$$R1 = 300k\Omega \times \left(\frac{2.5V}{0.6V} - 1 \right) = 950k\Omega$$

Power-OK (MAX25301B)

The MAX25301B includes an additional open-drain output, POK, that goes high to indicate the output voltage is in regulation. Connect a pullup resistor from this pin to an external supply. During startup, POK stays low until the output voltage rises to 91%(typ) of its regulation level. If an overload occurs at the output, or the output is shutdown, POK goes low.

Input Capacitor

A 10μF ceramic capacitor is recommended for the input. Select a capacitor that does not degrade significantly over temperature and DC bias. Capacitors with X5R or X7R temperature characteristics generally perform well.

Output Capacitor

A minimum of 4μF capacitance is required at OUT to ensure stability. Select a ceramic capacitor that maintains its capacitance (4μF minimum) over temperature and DC bias. Capacitors with X5R or X7R temperature characteristics generally perform well.

Thermal Considerations

The MAX25301A/B is packaged in an 10-pin 3mm x 3mm TDFN package with an exposed paddle. The exposed paddle is the main path for heat to leave the IC, and therefore must be connected to a ground plane with thermal vias to allow heat to dissipate from the device. Thermal properties of the IC package are given in the [Package Information](#) section.

Typical Application Circuits

Typical Application Circuits

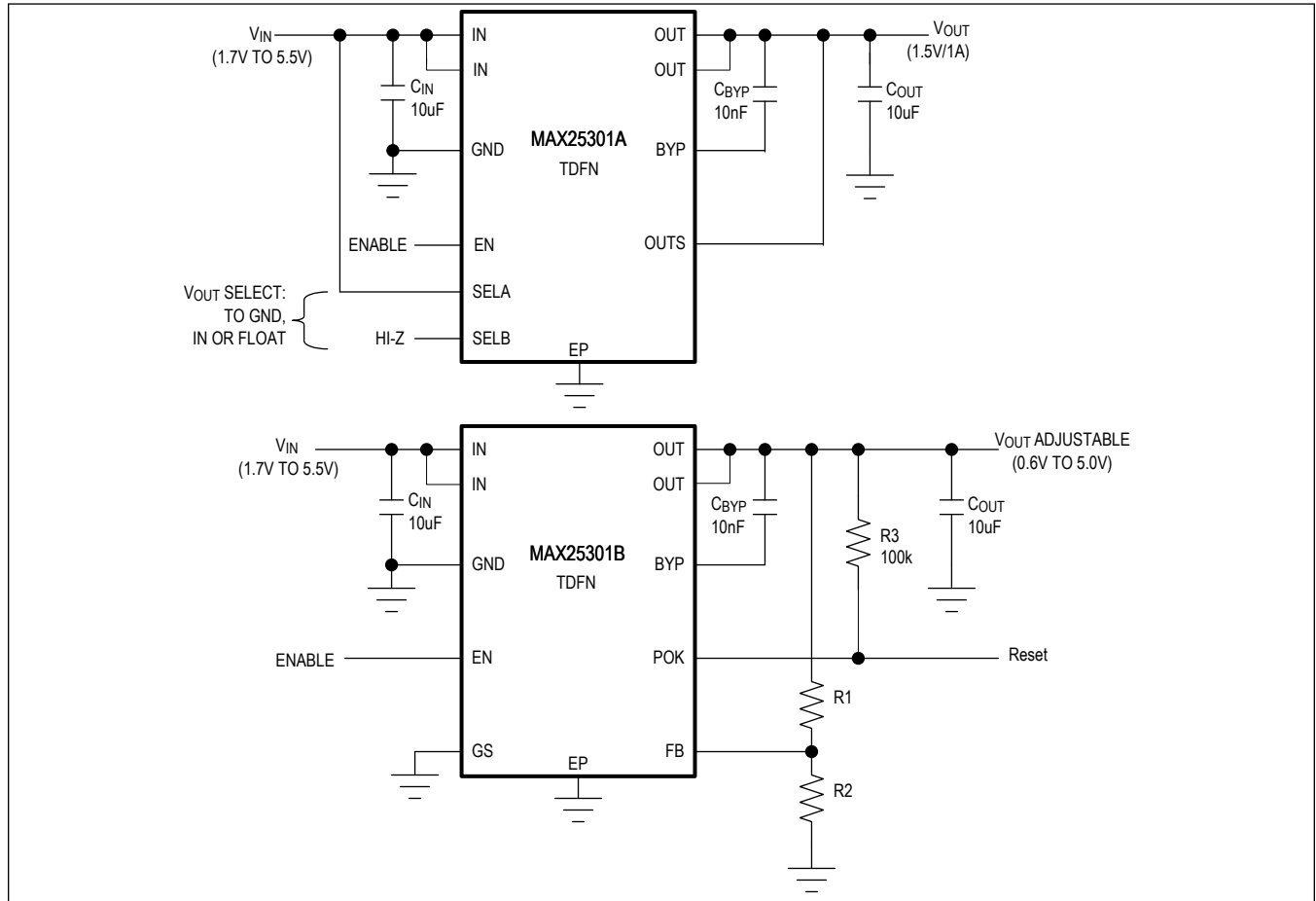

Ordering Information

PART NUMBER	TEMPERATURE RANGE	PIN-PACKAGE	FEATURES
MAX25301AATB/V+	-40°C to +125°C	10-pin TDFN 3mm x 3mm	Nine Selectable Output Voltages, Enable, Reset Output
MAX25301BATB/V+	-40°C to +125°C	10-pin TDFN 3mm x 3mm	Resistor-Configurable Output Voltage, Enable, Reset Output

V Denotes an automotive qualified part.

+Denotes a lead(Pb)-free/RoHS-compliant package.

Revision History

REVISION NUMBER	REVISION DATE	DESCRIPTION	PAGES CHANGED
0	6/20	Initial release	—

For pricing, delivery, and ordering information, please visit Maxim Integrated's online storefront at <https://www.maximintegrated.com/en/storefront/storefront.html>.

Maxim Integrated cannot assume responsibility for use of any circuitry other than circuitry entirely embodied in a Maxim Integrated product. No circuit patent licenses are implied. Maxim Integrated reserves the right to change the circuitry and specifications without notice at any time. The parametric values (min and max limits) shown in the Electrical Characteristics table are guaranteed. Other parametric values quoted in this data sheet are provided for guidance.

Looking for pricing, stock, or lifecycle information?

Click below to explore more details on WIN SOURCE:

 [View MAX25301BATB/V+ on WIN SOURCE](#)

 [Analog Devices Inc. Information](#)

Optimize Your Supply Chain with WIN SOURCE Solutions

-  Global Sourcing Solution
-  Obsolete Management
-  Cost Control Management
-  Shortage Management
-  Alternative Solution
-  Excess Inventory Management