



# THE DATASHEET OF HDSP-513E



# HDSP-511x, HDSP-513x, and HDSP-515A

## 14.22-mm (0.56-in.) General-Purpose Seven-Segment Display



### Description

This Broadcom<sup>®</sup> 14.22-mm (0.56-in.) LED seven-segment display uses industry-standard size package and pinout. The device is available in either common anode or common cathode. The choice of colors includes red, green, deep red, and yellow. The displays are suitable for indoor use.

### Applications

- Suitable for indoor use
- Not recommended for industrial applications. See the operating temperature range in the Absolute Maximum Ratings table. For additional details, contact your local Broadcom sales office or an authorized distributor.
- Extreme temperature cycling is not recommended.

### Features

- Industry-standard size
- Industry-standard pinout
  - 14.22-mm (0.56-in.) DIP lead on 2.54 mm
- Choice of colors: red, green, deep red, and yellow
- Excellent appearance
  - Optimum contrast achieved on gray surface upon light-up
  - $\pm 50^\circ$  viewing angle
- Design flexibility
  - Common anode or common cathode
  - Single digit
  - Right-hand decimal point
- Categorized for luminous intensity
  - Green and yellow categorized for color

### Devices

Red	Green	Deep Red	Yellow	Description
HDSP-511E	HDSP-511G	HDSP-511A	HDSP-511Y	Common Anode, Gray Surface, Right-Hand Decimal
HDSP-513E	HDSP-513G	HDSP-513A	HDSP-513Y	Common Cathode, Gray Surface, Right-Hand Decimal
—	—	HDSP-515A	—	Common Cathode, Black Surface, Right-Hand Decimal

# Package Dimensions

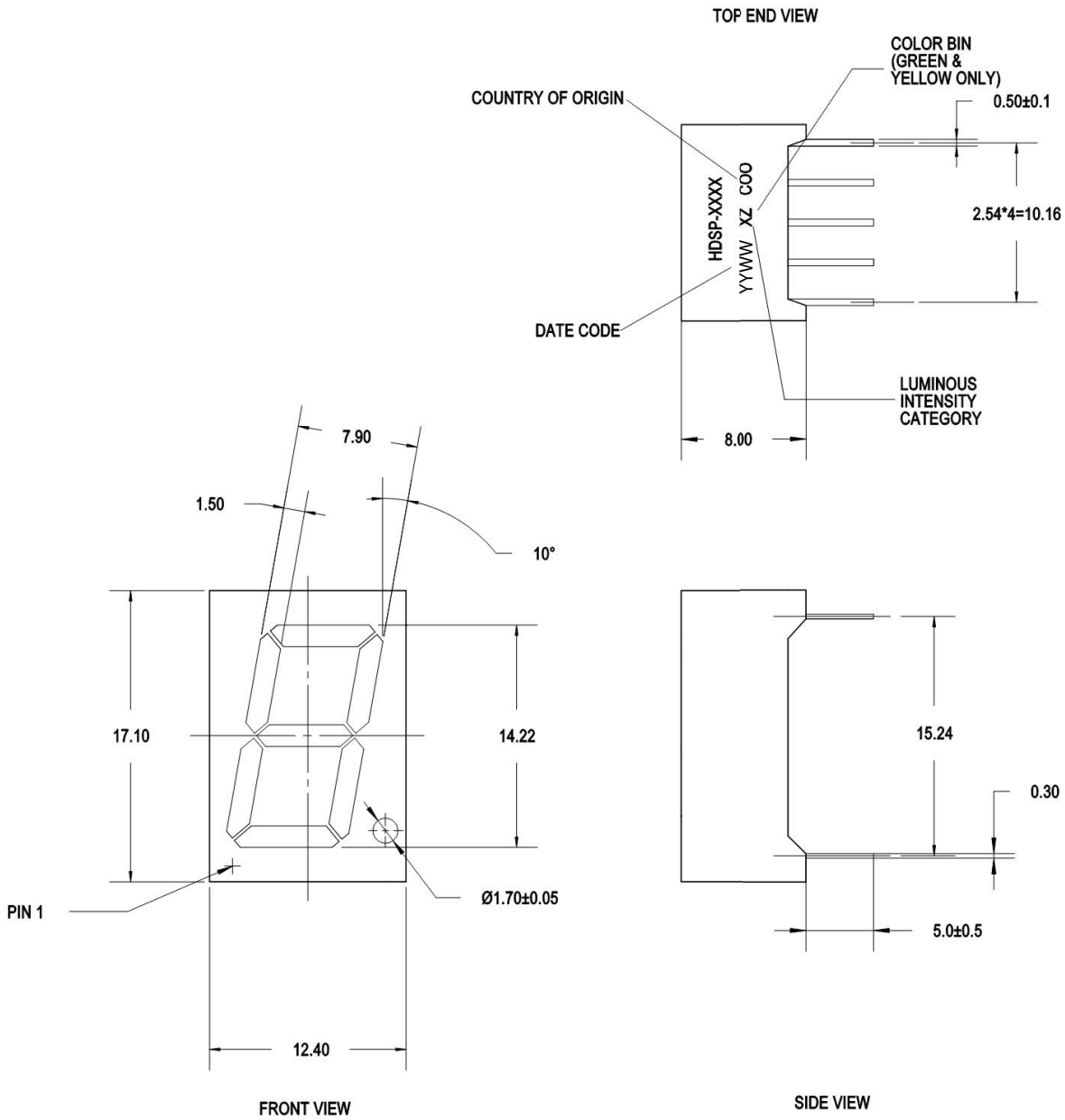

**NOTE:**

1. All dimensions are in millimeters (mm).
2. Tolerance is  $\pm 0.25$  mm unless otherwise specified.

## Internal Circuit Diagram

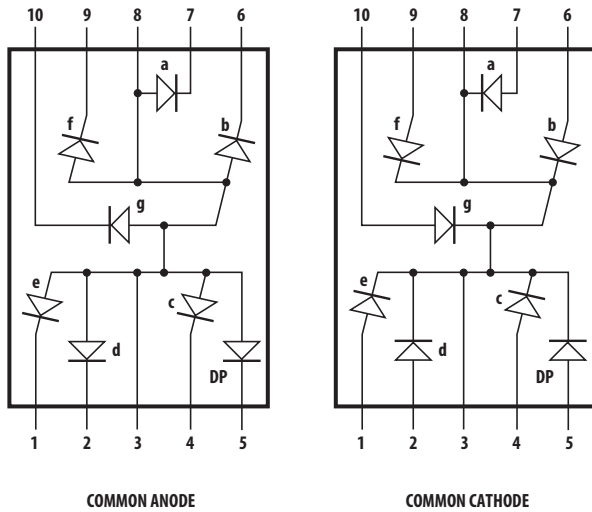

HDSP-511E/511G/511Y/511A		HDSP-513E/513G/513Y/513A/515A	
COMMON ANODE		COMMON CATHODE	
PIN	FUNCTION	PIN	FUNCTION
1	CATHODE e	1	ANODE e
2	CATHODE d	2	ANODE d
3	COMMON ANODE	3	COMMON CATHODE
4	CATHODE c	4	ANODE c
5	CATHODE DP	5	ANODE DP
6	CATHODE b	6	ANODE b
7	CATHODE a	7	ANODE a
8	COMMON ANODE	8	COMMON CATHODE
9	CATHODE f	9	ANODE f
10	CATHODE g	10	ANODE g

## Absolute Maximum Ratings at T<sub>A</sub> = 25°C

Description	Red HDSP-51xE	Green HDSP-51xG	Deep Red HDSP-51xA	Yellow HDSP-51xY	Units
Power Dissipation Segment	62.5	62.5	52	50	mW
Forward Current Segment	25 <sup>a</sup>	25 <sup>b</sup>	20 <sup>c</sup>	20 <sup>d</sup>	mA
Peak Forward Current per Segment <sup>e</sup>	90	90	60	60	mA
Operating Temperature Range	-40 to +85	-40 to +85	-40 to +85	-40 to +85	°C
Storage Temperature Range	-40 to +85	-40 to +85	-40 to +85	-40 to +85	°C
Reverse Voltage per Segment or DP <sup>f</sup>	5	5	5	5	V
Wavesoldering Temperature for 3 seconds (at 1.6-mm distance from the body)	250	250	250	250	°C

- a. Derate linearly as shown in [Figure 4](#).
- b. Derate linearly as shown in [Figure 8](#).
- c. Derate linearly as shown in [Figure 12](#).
- d. Derate linearly as shown in [Figure 16](#).
- e. Duty factor = 10%, frequency = 1 kHz, T<sub>A</sub> = 25°C.
- f. Reverse Voltage is for LED testing purposes and is not recommended to be used as an application condition.

## Electrical/Optical Characteristics at $T_A = 25^\circ\text{C}$

Device HDSP-	Parameter	Symbol	Min.	Typ.	Max.	Units	Test Conditions
<b>Red</b>							
511E 513E	Luminous Intensity/Segment <sup>a, b, c</sup>	$I_V$	5.05	7.50	—	mcd	$I_F = 10\text{ mA}$
	Forward Voltage <sup>d</sup>	$V_F$	—	1.95	2.50	V	$I_F = 20\text{ mA}$
	Peak Wavelength	$\lambda_P$	—	633	—	nm	
	Dominant Wavelength <sup>e</sup>	$\lambda_d$	—	622	—	nm	
	Reverse Voltage <sup>f</sup>	$V_R$	5	—	—	V	$I_R = 100\text{ }\mu\text{A}$
<b>Green</b>							
511G 513G	Luminous Intensity/Segment <sup>a, b, c</sup>	$I_V$	2.00	6.00	—	mcd	$I_F = 10\text{ mA}$
	Forward Voltage <sup>d</sup>	$V_F$	1.80	2.10	2.50	V	$I_F = 20\text{ mA}$
	Peak Wavelength	$\lambda_P$	—	572	—	nm	
	Dominant Wavelength <sup>e</sup>	$\lambda_d$	—	570	—	nm	
	Reverse Voltage <sup>f</sup>	$V_R$	5	—	—	V	$I_R = 100\text{ }\mu\text{A}$
<b>Deep Red</b>							
511A 513A 515A	Luminous Intensity/Segment <sup>a, b, c</sup>	$I_V$	3.201	6.500	—	mcd	$I_F = 10\text{ mA}$
	Forward Voltage <sup>d</sup>	$V_F$	—	2.00	2.60	V	$I_F = 20\text{ mA}$
	Peak Wavelength	$\lambda_P$	—	660	—	nm	
	Dominant Wavelength <sup>e</sup>	$\lambda_d$	—	640	—	nm	
	Reverse Voltage <sup>f</sup>	$V_R$	5	—	—	V	$I_R = 100\text{ }\mu\text{A}$
<b>Yellow</b>							
511Y 513Y	Luminous Intensity/Segment <sup>a, b, c</sup>	$I_V$	2.00	3.20	—	mcd	$I_F = 10\text{ mA}$
	Forward Voltage <sup>d</sup>	$V_F$	—	2.10	2.50	V	$I_F = 20\text{ mA}$
	Peak Wavelength	$\lambda_P$	—	592	—	nm	
	Dominant Wavelength <sup>e</sup>	$\lambda_d$	—	588	—	nm	
	Reverse Voltage <sup>f</sup>	$V_R$	5	—	—	V	$I_R = 100\text{ }\mu\text{A}$

- The luminous intensity,  $I_V$ , is measured at the mechanical axis of the package.
- The optical axis is closely aligned with the mechanical axis of the package.
- Tolerance is  $\pm 15\%$ .
- Forward voltage tolerance is  $\pm 0.1\text{V}$ .
- The dominant wavelength,  $\lambda_d$ , is derived from the CIE Chromaticity Diagram and represents the perceived color of the device.
- Reverse voltage is for product testing only. Long-term reverse bias is not recommended for end applications.

## Intensity Bin Limits (mcd at 10 mA)      Color Bin Limits (nm)

### Red

IV Bin Category	Min.	Max.
K	5.051	8.000
L	8.001	12.650
M	12.651	20.000

Tolerance for each bin limit is  $\pm 15\%$ .

### Green

IV Bin Category	Min.	Max.
I	2.001	3.200
J	3.201	5.050
K	5.051	8.000

Tolerance for each bin limit is  $\pm 15\%$ .

### Deep Red

IV Bin Category	Min.	Max.
J	3.201	5.050
K	5.051	8.000
L	8.001	12.650

Tolerance for each bin limit is  $\pm 15\%$ .

### Yellow

IV Bin Category	Min.	Max.
I	2.001	3.200
J	3.201	5.050
K	5.051	8.000

Tolerance for each bin limit is  $\pm 15\%$ .

Color	Dominant Wavelength (nm)		
	Bin	Min.	Max.
Green	3	569.1	571.0
	4	571.1	573.0
	5	573.1	575.0
Yellow	1	585.5	588.5
	2	588.5	591.5
	3	591.5	594.5

Tolerance for each bin limit is 1 nm.

# Red

Figure 1: Relative Intensity vs. Wavelength

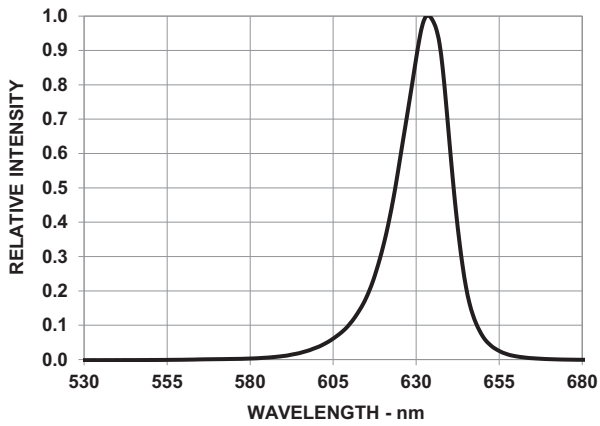

Figure 2: Forward Current vs. Forward Voltage

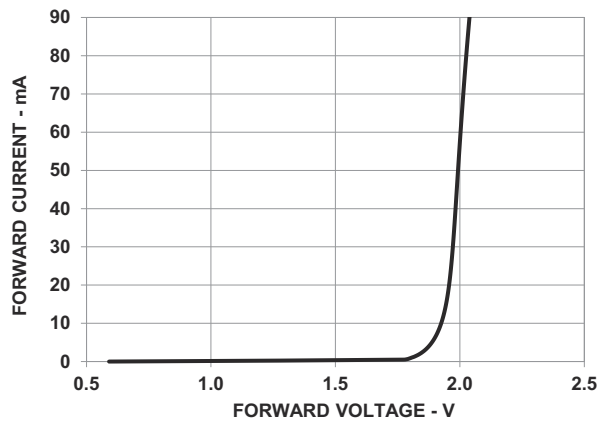

Figure 3: Relative Luminous Intensity vs. Forward Current

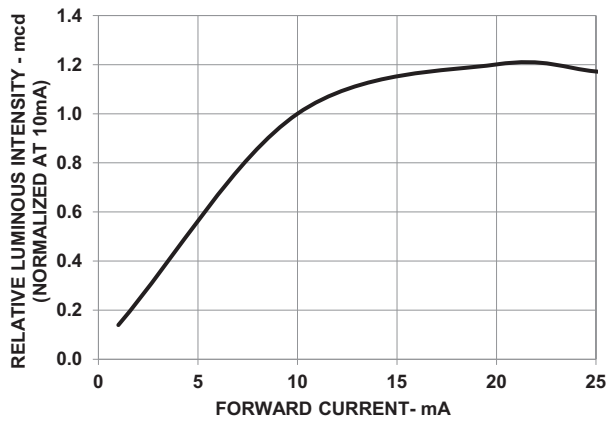
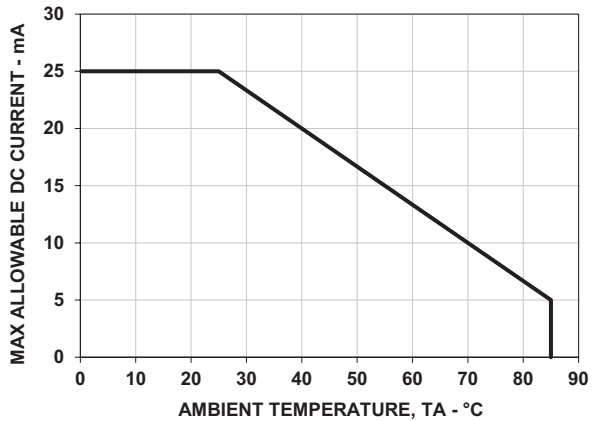

Figure 4: Maximum Forward Current vs. Ambient Temperature



# Green

Figure 5: Relative Intensity vs. Wavelength

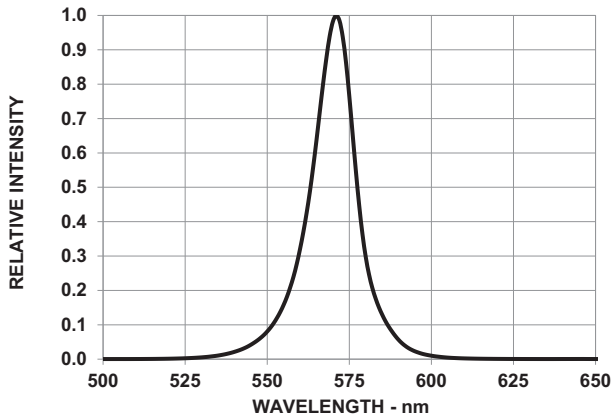

Figure 6: Forward Current vs. Forward Voltage

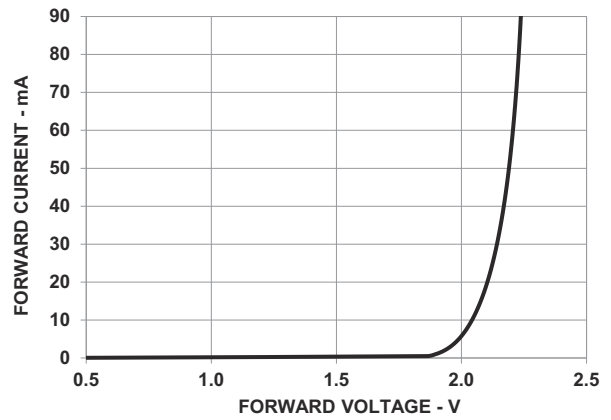

Figure 7: Relative Luminous Intensity vs. Forward Current

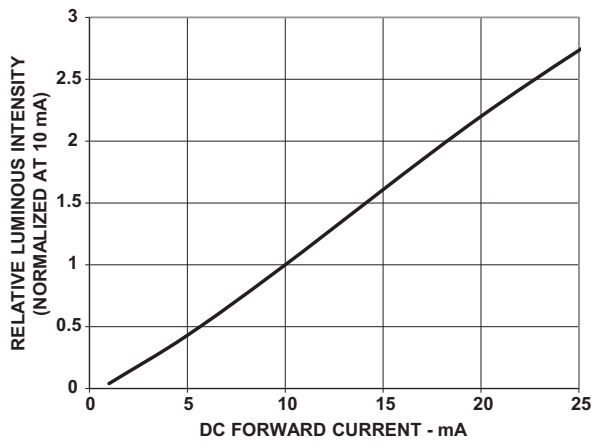
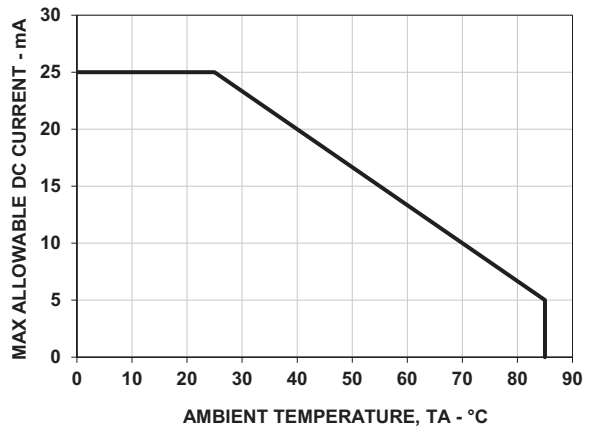

Figure 8: Maximum Forward Current vs. Ambient Temperature



# Deep Red

Figure 9: Relative Intensity vs. Wavelength

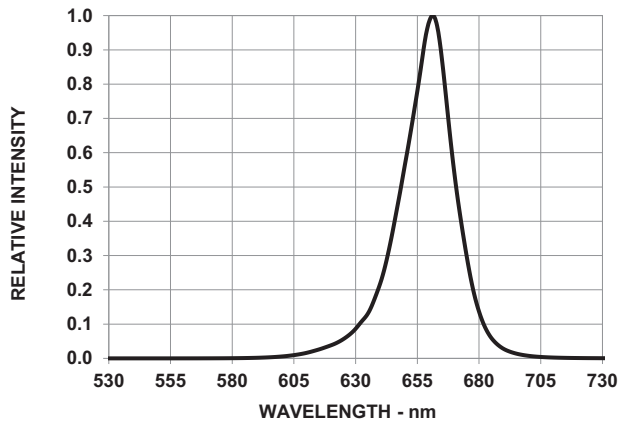

Figure 10: Forward Current vs. Forward Voltage

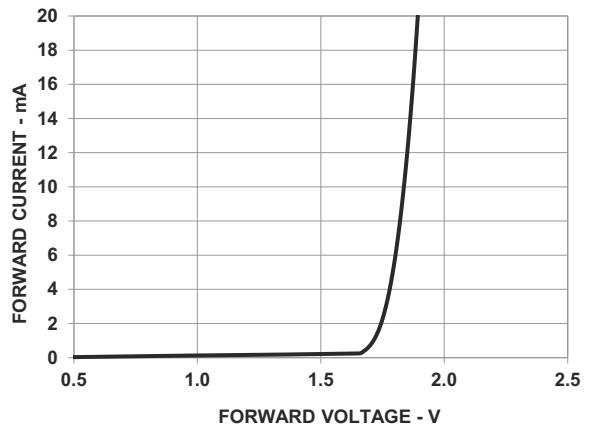

Figure 11: Relative Luminous Intensity vs. Forward Current

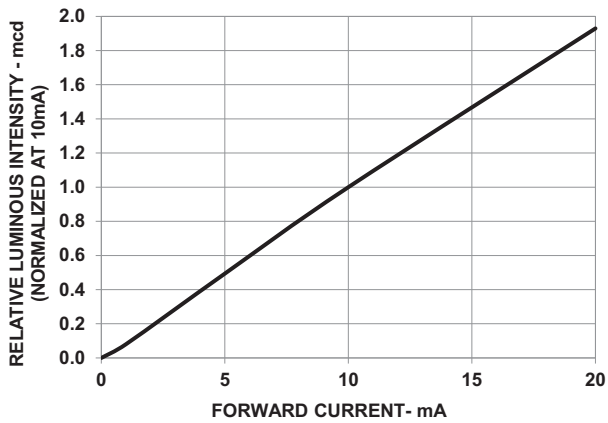
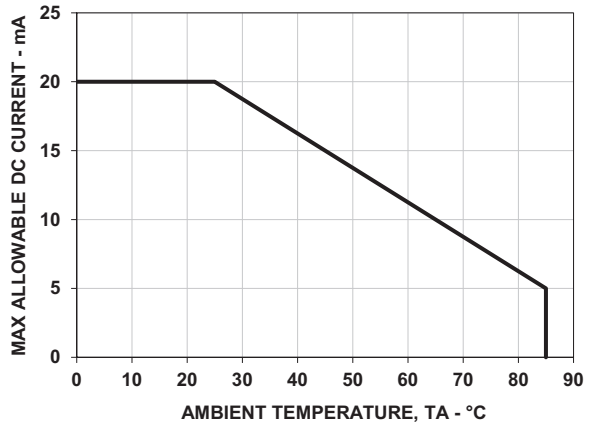

Figure 12: Maximum Forward Current vs. Ambient Temperature



# Yellow

Figure 13: Relative Intensity vs. Wavelength

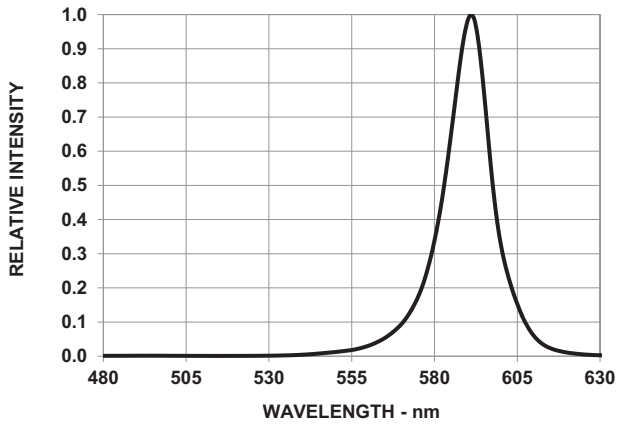

Figure 14: Forward Current vs. Forward Voltage

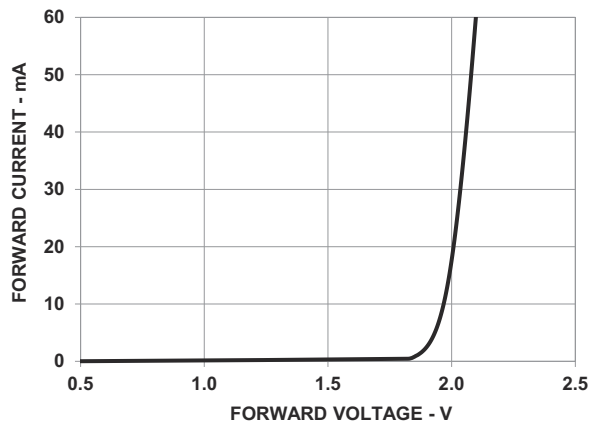

Figure 15: Relative Luminous Intensity vs. Forward Current

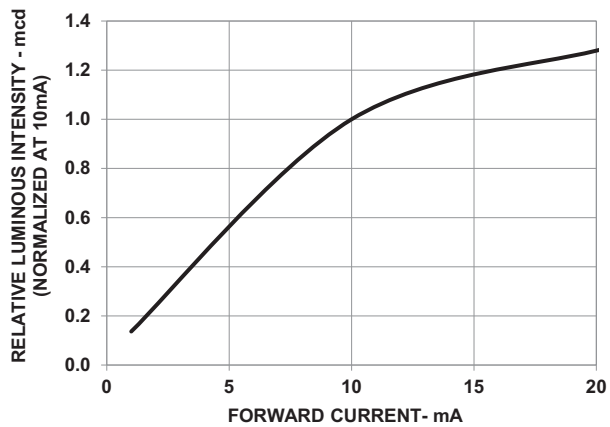
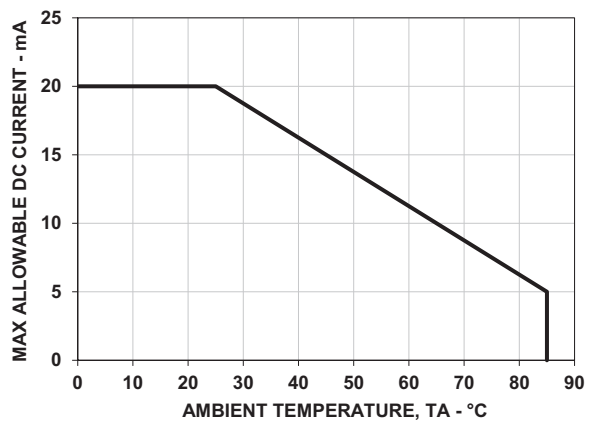

Figure 16: Maximum Forward Current vs. Ambient Temperature



## Precautionary Notes

### Soldering and Handling Precautions

- Set and maintain the wave soldering parameters according to the recommended temperature and dwell time. Perform daily checks on the profile to ensure that it always conforms to the recommended conditions. Exceeding these conditions will over-stress the LEDs and cause premature failures.
- Use only bottom preheaters to reduce thermal stress experienced by the LEDs.
- Recalibrate the soldering profile before loading a new type of PCB. PCBs with different sizes and designs (component density) have different heat capacity and might cause a change in temperature experienced by the PCB if the same wave soldering setting is used
- Do not perform wave soldering more than once.
- Any alignment fixture used during wave soldering must be loosely fitted and must not apply stress on the LEDs. Use nonmetal material because it absorbs less heat during the wave soldering process.
- At elevated temperatures, the LEDs are more susceptible to mechanical stress. Allow the PCB to be sufficiently cooled to room temperature before handling. Do not apply stress to the LED when it is hot.
- Use wave soldering to solder the LED. Use hand soldering only for rework or touch up if unavoidable, but it must be strictly controlled to following conditions:
  - Soldering iron tip temperature = 315°C maximum.
  - Soldering duration = 2 seconds maximum.
  - Number of cycle = 1 only.
  - Power of soldering iron = 50W maximum.
- For ESD-sensitive devices, apply proper ESD precautions at the soldering station. Use only an ESD-safe soldering iron.
- Do not touch the LED package body with the soldering iron except for the soldering terminals because it may cause damage to the LED.
- Confirm beforehand whether the functionality and performance of the LED is affected by soldering with hand soldering.
- Keep the heat source at least 1.6 mm away from the LED body during soldering.
- Design appropriate hole size to avoid problems during insertion.
- Do not use cleaning agents from the ketone family (acetone, methyl ethylketone, etc.) and from the chlorinated hydrocarbon family (methylene chloride, trichloroethylene, carbon tetrachloride, and so on) for

cleaning the LED displays. All of these various solvents attack or dissolve the encapsulating epoxies used to form the package of plastic LED parts.

- For the purpose of cleaning, wash with DI water only. The cleaning process should take place at room temperature only. Clear any water or moisture from the LED display immediately after washing.
- Use *No clean* solder paste for soldering.

Figure 17: Recommended Wave Soldering Profile

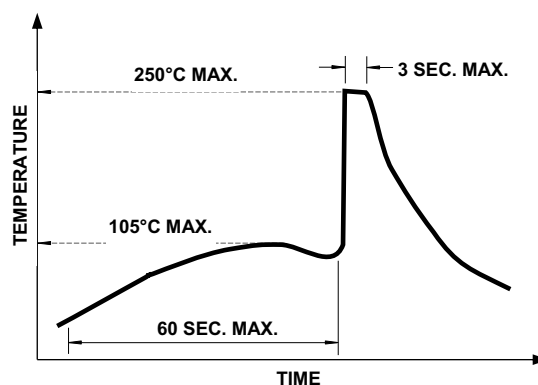

**NOTE:** Refers to measurements with thermocouple mounted at the bottom of the PCB.

### Application Precautions

- The drive current of the LED must not exceed the maximum allowable limit across temperature as stated in the data sheet. Constant current driving is recommended to ensure consistent performance.
- The circuit design must cater to the entire range of forward voltage ( $V_F$ ) of the LEDs to ensure the intended drive current can always be achieved.
- The LED exhibits slightly different characteristics at different drive currents, which may result in a larger variation of performance (meaning: intensity, wavelength, and forward voltage). Set the application current as close as possible to the test current to minimize these variations.
- The LED is not intended for reverse bias. Use other appropriate components for such purposes. When driving the LED in matrix form, ensure that the reverse bias voltage does not exceed the allowable limit of the LED.

- Avoid rapid changes in ambient temperature, especially in high-humidity environments, because they cause condensation on the LED.
- If the LED is intended to be used in harsh or outdoor environments, protect the LED against damages caused by rain, water, dust, oil, corrosive gases, external mechanical stresses, and so on.

## Eye Safety Precautions

LEDs may pose optical hazards when in operation. Do not look directly at operating LEDs because it might be harmful to the eyes. For safety reasons, use appropriate shielding or personal protective equipment.

## Disclaimer

Broadcom's products and software are not specifically designed, manufactured, or authorized for sale as parts, components, or assemblies for the planning, construction, maintenance, or direct operation of a nuclear facility or for use in medical devices or applications. The customer is solely responsible, and waives all rights to make claims against Broadcom or its suppliers, for all loss, damage, expense, or liability in connection with such use.

Copyright © 2008–2024 Broadcom. All Rights Reserved. The term “Broadcom” refers to Broadcom Inc. and/or its subsidiaries. For more information, go to [www.broadcom.com](http://www.broadcom.com). All trademarks, trade names, service marks, and logos referenced herein belong to their respective companies.

Broadcom reserves the right to make changes without further notice to any products or data herein to improve reliability, function, or design. Information furnished by Broadcom is believed to be accurate and reliable. However, Broadcom does not assume any liability arising out of the application or use of this information, nor the application or use of any product or circuit described herein, neither does it convey any license under its patent rights nor the rights of others.



Lead (Pb) Free  
RoHS Compliant

## Looking for pricing, stock, or lifecycle information?

Click below to explore more details on WIN SOURCE:

 [View HDSP-513E on WIN SOURCE](#)

 [Broadcom Limited](#) Information

## Optimize Your Supply Chain with WIN SOURCE Solutions

-  Global Sourcing Solution
-  Obsolete Management
-  Cost Control Management
-  Shortage Management
-  Alternative Solution
-  Excess Inventory Management