



THE DATASHEET OF CYPD6127-48LQXIT



USB Type-C port controller

General description

EZ-PD™ CCG6DF and EZ-PD™ CCG6SF are dual-port and single-port USB Type-C controllers that comply with the latest USB Type-C and PD specifications. These devices provide a complete USB Type-C and USB Power Delivery port control solution for PCs and notebooks. Both of these devices include a VBUS provider path load switch. These devices also contain a true random number generator (TRNG) for authentication, a 32-bit, 48-MHz Arm® Cortex®-M0 processor with 64-KB flash and 96-KB ROM, integrating a complete Type-C transceiver including the Type-C termination resistors Rp, Rd, and dead battery Rd termination. CCG6DF is available in a 96-ball BGA package, whereas CCG6SF is available in 48-pin QFN package.

Applications

- Notebooks and desktops
- Thunderbolt hosts, non-thunderbolt hosts

Features

USB PD

- Supports latest USB PD 3.0 specification
- Fast role swap (FRS)
- Extended data messaging

Type-C

- Integrated current sources for DFP^[1] role (Rp)
 - Default current at 900 mA
 - 1.5 A
 - 3 A
- Integrated Rd resistor for upstream facing port (UFP^[2])role
- Integrated VCONN FETs to power EMCA cables
- Integrated dead battery termination
- Integrated high-voltage protection on CC and SBU pins to protect against accidental shorts to the VBUS pin on the Type-C connector
- Integrated pass through SBU switch for 20-V protection

Mux

- Integrated USB 2.0 analog mux for USB 2.0 HS and UART data

Notes

1. DFP refers to power source.
2. UFP refers to power sink.

Features

Integrated provider VBUS load switch

- VBUS provider switch (5 V/3 A)
- Slew rate controlled turn-on on the VBUS provider path, tolerant to 24 V
- Configurable hardware-controlled VBUS overvoltage, undervoltage, overcurrent, short circuit, reverse current protection, and thermal shutdown
- VBUS high-side current sense amplifier capable of measuring current across 5-mΩ series resistance on the provider path
- In response to fast role swap request, turns OFF external consumer N-channel field effect transistor (NFET) and turns ON internal provider load switch

LDO

- Integrated high-voltage LDO operational up to 21.5 V for dead battery mode operation

32-bit MCU subsystem

- 48-MHz Arm® Cortex®-M0 CPU
- 64-KB Flash
- 96-KB ROM
- 16-KB SRAM

Integrated digital blocks

- Two integrated timers and counters to meet response times required by the USB PD protocol
- Four run-time serial communication blocks (SCBs) with reconfigurable I²C, SPI, or UART functionality

Authentication

- True random number generator

Clocks and oscillators

- Integrated oscillator eliminating the need for an external clock

Operating range

- VSYS (2.75 V–5.5 V)
- VBUS (4 V–21.5 V)

Hot-swappable I/Os

- I²C pins from SCB0 are hot-swappable

Packages

- CCG6DF: 6.0 mm × 6.0 mm × 1.0 mm, 96-ball BGA with 0.5-mm pitch
- CCG6SF: 6.0 mm × 6.0 mm × 0.6 mm, 48-pin QFN with 0.4-mm pitch

Logic block diagram

Logic block diagram

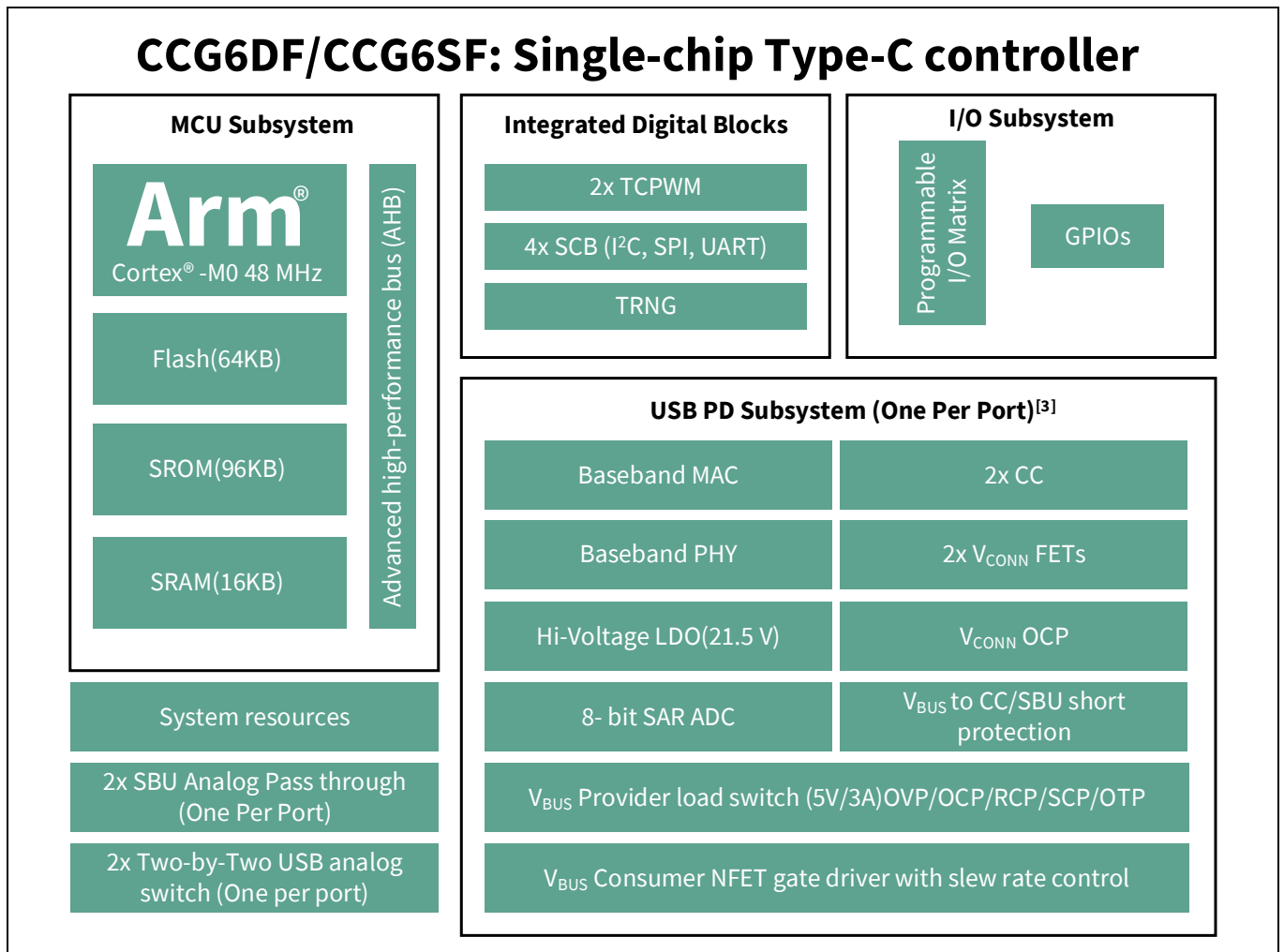

Note

3. Only one USB PD subsystem exists for CCG6SF devices since it has only one Type-C port available.

CCG6DF/CCG6SF functional diagram

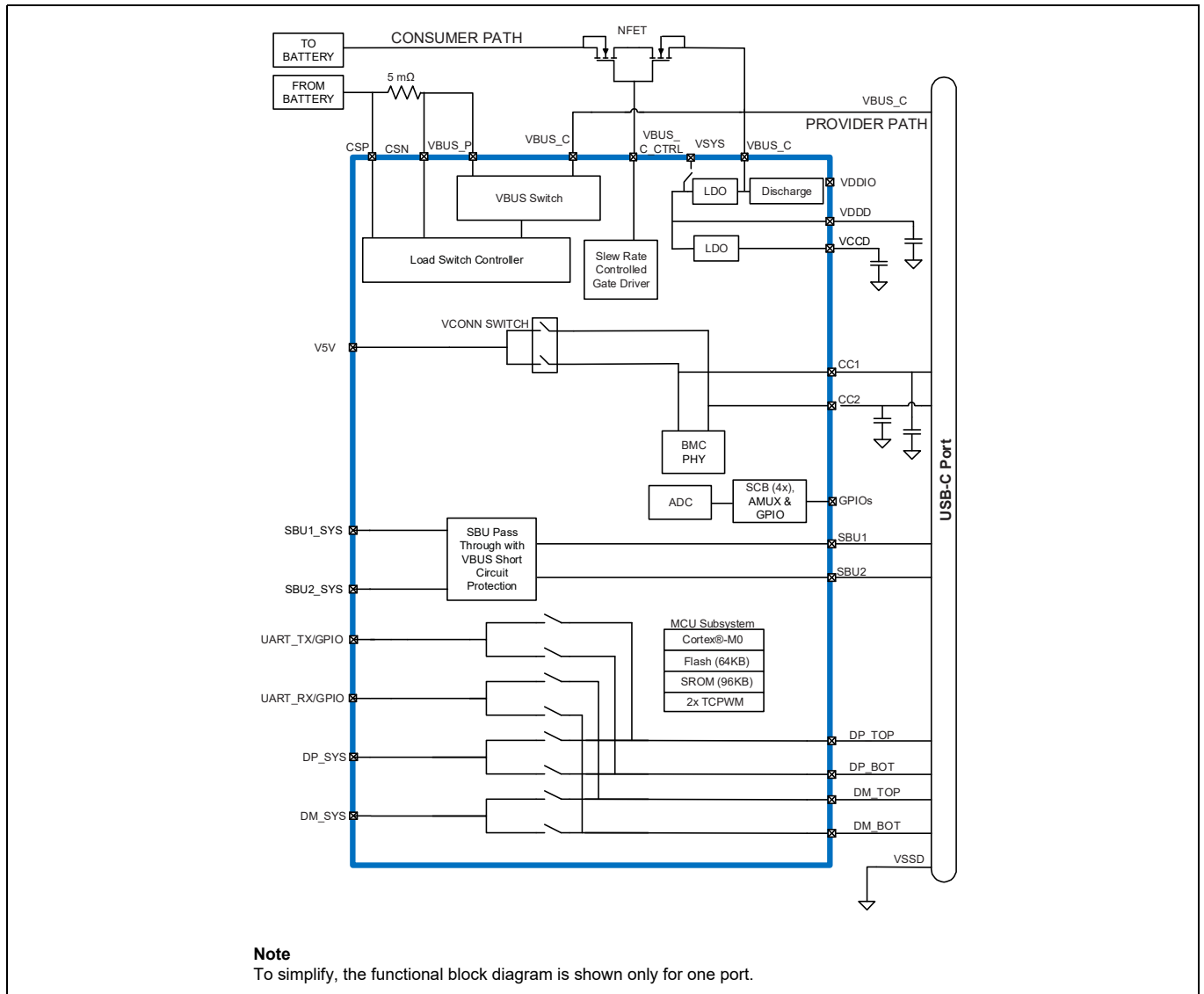

Table of contents

General description	1
Applications	1
Features	1
Logic block diagram	3
CCG6DF/CCG6SF functional diagram	4
Table of contents	5
1 Functional overview	7
1.1 MCU subsystem.....	7
1.1.1 CPU	7
1.1.2 Flash, SROM, and RAM	7
1.2 USB PD subsystem (SS)	7
1.2.1 USB PD physical layer	7
1.2.2 VCONN FET	8
1.2.3 ADC	8
1.2.4 SBU pass-through switch and USB HS mux.....	8
1.3 Provider load switch	9
1.3.1 Undervoltage and overvoltage protection on VBUS.....	9
1.3.2 High-side current sense amplifier for VBUS	9
1.3.3 VBUS reverse current protection (RCP)	9
1.3.4 VBUS short circuit protection (SCP).....	9
1.3.5 VBUS discharge	9
1.3.6 VBUS regulator.....	9
1.3.7 Gate driver for VBUS NFET.....	9
1.3.8 VBUS tolerant SBU and CC lines.....	9
1.4 Serial communication block (SCB)	10
1.5 Timer, counter, pulse-width modulator (TCPWM)	10
1.6 True random number generator (TRNG)	10
1.7 GPIO interface	10
1.8 System resources.....	11
1.8.1 Watchdog timer (WDT)	11
1.8.2 Clock system	11
1.8.3 IMO clock source	11
1.8.4 ILO clock source	11
2 Power	12
3 Pinouts	14
4 Application diagrams	21
5 CCG6DF layout design guidelines for BGA package	24
5.1 Usage of via size of 8-mil drill/16-mil diameter and 10-mil drill/16-mil diameter	25
5.1.1 Layer stack-up.....	26
5.1.2 Top layer fanout.....	26
5.1.3 Via count for GND pads.....	27
5.1.4 Via count for provider pads	27
5.1.5 High-speed (DP_SYS, DM_SYS) USB connections	28
5.1.6 Rsense and capacitor connections for provider VBUS.....	29
5.1.7 Trace width details for critical signals	30
5.1.8 VDDIO, VCCD, VSYS, and VDDD connections.....	31
5.1.9 Capacitor connections for CC lines and bypass capacitors for VDDIO, VDDD, VCCD, and VSYS pins	32
6 CCG6SF layout design guidelines for 48-QFN package	33
6.1 Recommended pad size	33
6.2 Stack-up	34
6.3 48-QFN fanout.....	34

6.4 Via count on thermal pads	35
6.5 Via count for VBUS_P and VBUS_C pads	35
6.6 High-speed (DP/DM_SYS, DP/DM_BOT, DP/DM_TOP) USB connections fanout	36
6.7 CC connections	37
6.8 VDDIO, VCCD, VSYS, and VDDD connections.....	38
7 Electrical specifications.....	39
7.1 Absolute maximum ratings	39
7.2 Device-level specifications	41
7.2.1 DC specifications.....	41
7.2.2 CPU	43
7.2.3 GPIO.....	44
7.2.4 XRES.....	45
7.3 Digital peripherals.....	46
7.3.1 Pulse width modulation (PWM) for GPIO pins.....	46
7.3.2 I2C	46
7.3.3 UART	46
7.3.4 SPI.....	47
7.3.5 Memory.....	48
7.4 System resources.....	49
7.4.1 Power-on-reset (POR) with brown out	49
7.4.2 SWD interface.....	49
7.4.3 Internal main oscillator	49
7.4.4 Internal low-speed oscillator	50
7.4.5 Consumer NGDO	50
7.4.6 PD.....	51
7.4.7 Analog-to-digital converter	52
7.4.8 VSYS switch	52
7.4.9 CSA.....	53
7.4.10 VBUS UV/OV.....	54
7.4.11 Provider side RCP.....	54
7.4.12 SBU switch.....	56
7.4.13 DP/DM switch	58
7.4.14 VCONN switch	60
7.4.15 VBUS	61
8 Ordering information	62
8.1 Ordering code definitions.....	62
9 Packaging	63
10 Acronyms	66
11 Document conventions.....	69
11.1 Units of measure	69
11.2 References and links to applications collateral	70
11.2.1 Knowledge base articles.....	70
11.2.2 Application notes	70
11.2.3 Reference designs.....	70
11.2.4 Kits	71
11.2.5 Datasheets.....	71
Revision history	72

1 Functional overview

1.1 MCU subsystem

1.1.1 CPU

The Cortex[®]-M0 in CCG6DF and CCG6SF devices is a 32-bit MCU, which is optimized for low-power operation with extensive clock gating. It mostly uses 16-bit instructions and executes a subset of the Thumb-2 instruction set, which enables fully compatible binary upward migration of code to higher performance processors such as Cortex[®] M3 and M4. Also included is a hardware multiplier, which provides a 32-bit result in one cycle. It includes an interrupt controller (the NVIC block) with 32 interrupt inputs and a wakeup interrupt controller (WIC), which can wake the processor up from Deep Sleep mode.

1.1.2 Flash, SRAM, and RAM

The 64-KB Flash and 96-KB ROM store the firmware implementing PD functionality.

The 16-KB RAM is used under software control to store temporary status of system variables and parameters. A supervisory ROM that contains boot and configuration routines is provided.

1.2 USB PD subsystem (SS)

This subsystem provides the interface to the Type-C USB port. This subsystem comprises of:

- USB PD physical layer
- VCONN FETs
- ADC
- SBU pass-through switch and USB HS mux
- Undervoltage, overvoltage and reverse-current protection on VBUS
- High-side current sense amplifier for VBUS
- VBUS discharge
- VBUS regulator
- Consumer gate driver for VBUS NFET
- Integrated VBUS provider path load switch with FRS
- VBUS tolerant SBU and CC pins

1.2.1 USB PD physical layer

The USB PD subsystem contains the USBPD physical layer block and supporting circuits. The USB PD physical layer consists of a transmitter and receiver that communicate BMC encoded data over the CC channel per the PD 3.0 standard. All communication is half-duplex. The physical layer or PHY practices collision avoidance to minimize communication errors on the channel.

In addition, the USB PD block includes all termination resistors (R_P and R_D) and their switches as required by the USB Type-C spec. R_P and R_D resistors are required to implement connection detection, plug orientation detection and for establishment of the USB source/sink roles. The R_P resistor is implemented as a current source. The R_D resistors on CC pins are required even when the part is not powered on. This is required for dead battery termination detection and charging.

To support the latest USB PD 3.0 specification, CCG6DF and CCG6SF devices implement the FRS feature. Fast role swap enables externally powered docks and hubs to rapidly switch to bus power when their external power supply is removed. This feature is supported for provider N-FET gate driver output (NGDO). SCP and RCP fault detection are not enabled during the FRS sequence and it is assumed that provider side supply is present and higher than 4.85 V.

CCG6DF and CCG6SF devices are designed to be fully interoperable with revision 3.0 of the USB Power Delivery specification as well as revision 2.0 of the USB Power Delivery specification.

1.2.2 VCONN FET

CCG6DF and CCG6SF devices have power supply input V5V pin for providing power to EMCA cables through integrated VCONN FETs. There are two VCONN FETs per port in CCG6DF and CCG6SF devices to power either CC1 or CC2 pins. These FETs source a minimum of 1.5-W power per port over the valid VCONN range of 4.85 V to 5.5 V on the CC1/2 pins when providing power to EMCA cables. At any given time, only one of the VCONN FETs is in ON state to provide VCONN on either CC1 or CC2 lines depending on the cable orientation. The floating V5V pin does not cause CCG6DF to malfunction and draw more current.

1.2.3 ADC

CCG6DF and CCG6SF devices have a low power 8-bit SAR ADC that has access to the chip-wide analog mux. All GPIOs on these devices have access to the ADCs through the chip-wide analog mux.

1.2.4 SBU pass-through switch and USB HS mux

CCG6DF has integrated 2x SBU pass-through switches and 2x high-speed (480 Mbps) switches as shown in [Figure 1](#).

The SBU switch is a simple pass-through switch. The Type-C facing SBU pins are protected from accidental short to VBUS.

The HS mux contains a 2 × 2 cross bar switch to route the system DP/DM lines to the Type-C top or bottom lines as per the CC (Type-C plug) orientation and connect the debug pins to unused DP or DM top or bottom pins.

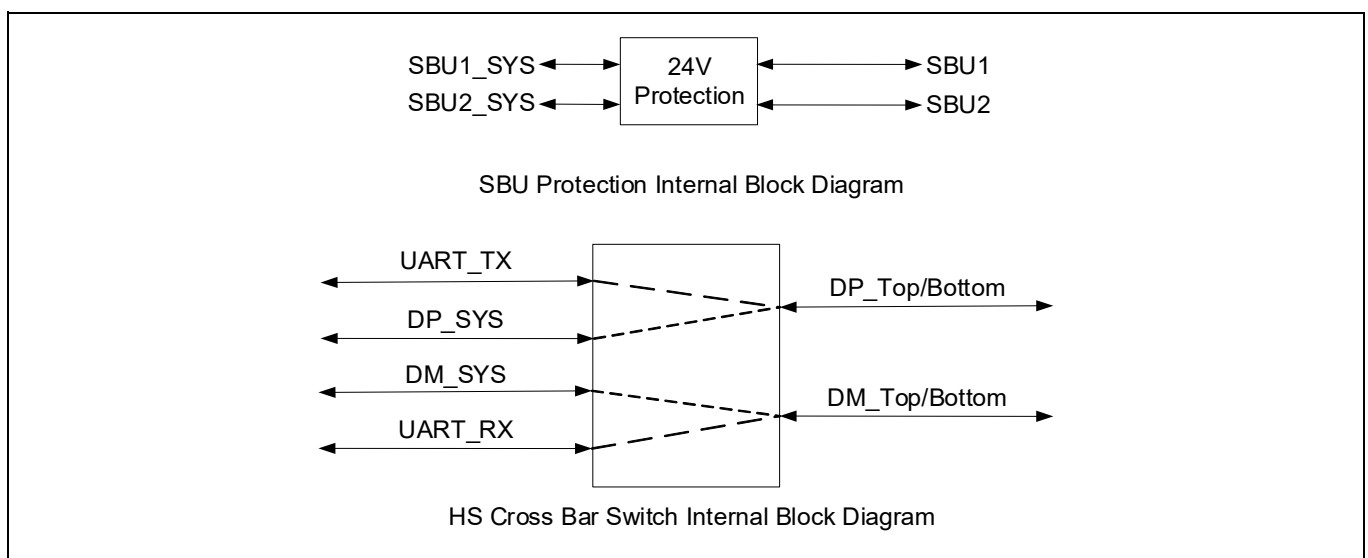

Figure 1 SBU protection and high-speed crossbar switch block diagram

1.3 Provider load switch

CCG6DF and CCG6SF devices have an integrated provider load switch with the following functions.

1.3.1 Undervoltage and overvoltage protection on VBUS

CCG6DF and CCG6SF devices implement an undervoltage/overvoltage (UVOV) detection circuit for the VBUS supply. The thresholds for both overcurrent protection (OCP) and UVOV are programmable.

1.3.2 High-side current sense amplifier for VBUS

CCG6DF and CCG6SF devices support the programmable threshold VBUS current sensing through VBUS provider path. External resistor (5 m Ω) placed in VBUS provider path connecting to the chip, the drop across this resistor is monitored to sense the magnitude of current.

1.3.3 VBUS reverse current protection (RCP)

CCG6DF and CCG6SF devices restrict reverse current to zero on the VBUS provider path when the Type-C VBUS is greater than VIN (provider voltage before the VBUS NFET).

1.3.4 VBUS short circuit protection (SCP)

CCG6DF and CCG6SF devices have a VBUS short circuit protection function of which the SCP threshold is programmable. Whenever current through the VBUS provider load switch exceeds the programmed threshold, the SCP gets triggered instantly and turns off the VBUS provider path within a short duration.

1.3.5 VBUS discharge

CCG6DF and CCG6SF devices support high-voltage (21.5 V) VBUS discharge circuitry inside. After cable removal detection, the chips discharge the residual charge and bring the floating VBUS to less than 0.8 V.

1.3.6 VBUS regulator

CCG6DF and CCG6SF devices can either be powered by VSYS or VBUS power supplies. There is one VBUS per port. Hence the CCG6DF device can be powered by either VBUS (port0 or port1) or VSYS. A regulator operating on these power supplies derives the chip operating supply. When both power supplies are present, VSYS always takes priority over VBUS supplies. In absence of VSYS, the regulator powers the chip from VBUS.

1.3.7 Gate driver for VBUS NFET

CCG6DF and CCG6SF devices have integrated gate drivers to drive external NFETs on the VBUS consumer path. The provider NFETs are integrated. The consumer side supports only the external NFET driver and these NFETs must be capable of supporting \pm VBUS_MAX VGS. CCG6DF and CCG6SF must be in active mode to enable the consumer-side NGDO.

1.3.8 VBUS tolerant SBU and CC lines

CCG6DF and CCG6SF devices support VBUS tolerant SBU and CC lines. In case of SBU/CC short to VBUS through connectors, these lines are protected internally. Accidental shorts may occur because the SBU/CC pins are placed next to the VBUS pins in the USB Type-C connector. A Power Delivery controller without the high-voltage VBUS short protection will be damaged in the event of such accidental shorts. When overvoltage is detected on the SBU/CC lines, the internal protection circuit will turn off the connection between the Type-C connector and the rest of the device.

1.4 Serial communication block (SCB)

CCG6DF and CCG6SF devices have four SCB blocks that can be configured for I²C, SPI, or UART. These blocks implement full multi-master and slave I²C interfaces capable of multi-master arbitration. I²C is compatible with the standard Philips I²C specification V3.0. These blocks operate at speeds of up to 1 Mbps and have flexible buffering options to reduce interrupt overhead and latency for the CPU.

The SCB blocks support 8-byte deep FIFOs for receive and transmit, which, by increasing the time given for the CPU to read data, greatly reduces the need for clock stretching caused by the CPU not having read data on time.

1.5 Timer, counter, pulse-width modulator (TCPWM)

The TCPWM block of CCG6DF and CCG6SF supports up to two timers or counters or pulse-width modulators. These timers are available for internal timer use by firmware or for providing PWM-based functions on the GPIOs.

1.6 True random number generator (TRNG)

In notebook designs, CCG6DF's and CCG6SF's TRNG block is used in authenticating connected devices such as power adapters or docks that include support for USB Type-C authentication specification (USBTCAS). CCG6DF and CCG6SF devices, within notebook applications, are implemented as an initiator role as defined in USBTCAS, while the connected device would implement the responder-role. USBTCAS provides a means for authenticating Type-C devices with regards to identification and configuration.

1.7 GPIO interface

The CCG6DF device has 23 GPIOs and the CCG6SF device has 19 GPIOs including the I²C and SWD pins, which can also be used as GPIOs.

The GPIO block implements the following:

- Eight drive strength modes including strong push-pull, resistive pull-up and pull-down, weak (resistive) pull-up and pull-down, open drain and open source, input only, and disabled.
- Input threshold select (CMOS or LVTTTL)
- Individual control of input and output disables
- Hold mode for latching previous state (used for retaining I/O state in Deep Sleep mode)
- Selectable slew rates for dV/dt related noise control

During power-on and reset, the blocks are forced to the disable state so as not to crowbar any inputs and/or cause excess turn-on current. A multiplexing network known as a high-speed I/O matrix is used to multiplex between various signals that may connect to an I/O pin. Pin locations for fixed-function peripherals, such as USB Type-C ports, are also fixed to reduce internal multiplexing complexity. Data output registers and pin state register store, respectively, the values to be driven on the pins and the states of the pins themselves. The configuration of the pins can be done by programming of registers through software for each digital I/O port.

Every I/O pin can generate an interrupt if so enabled and each I/O port has an IRQ and ISR vector associated with it.

The I/O ports retain their state during Deep Sleep mode or remain ON. If operation is restored using reset, then the pins shall go the High-Z state. If operation is restored by an interrupt event, then the pin drivers shall retain their state until firmware chooses to change it. The I/Os (on data bus) do not draw current on power down.

All GPIOs reside in a separate I/O power domain – VDDIO to provide flexible system-level interfacing.

1.8 System resources

1.8.1 Watchdog timer (WDT)

A watchdog timer is implemented in the Clock block running from the internal low-speed oscillator (ILO) for CCG6DF and CCG6SF devices. This allows watchdog operation during Deep Sleep and generates a watchdog reset if not serviced before the timeout occurs.

In addition to the chip-level watchdog timer, each USB PD block implements a counter based on ILO (Low frequency) clock which can be used to wake/trigger the part periodically. This counter can be used to drive any periodic tasks to be performed by the device.

1.8.2 Clock system

CCG6DF and CCG6SF have a fully integrated clock with no external crystal required. CCG6DF/CCG6SF clock system is responsible for providing clocks to all subsystems that require clocks (SCB and USB PD) and for switching between different clock sources, without glitches. The clock system for these devices consists of the internal main oscillator (IMO) and the ILO.

1.8.3 IMO clock source

The IMO is the primary source of internal clocking in CCG6DF and CCG6SF devices with an accuracy of $\pm 2\%$. The default IMO frequency for CCG6DF and CCG6SF devices is 48 MHz $\pm 2\%$.

1.8.4 ILO clock source

The ILO is a very low power, relatively inaccurate, oscillator, which is primarily used to generate clocks for peripheral operation in USB Suspend (Deep Sleep) mode. The typical frequency of the ILO is 32-kHz.

2 Power

CCG6DF can operate either from VBUS_C (from Port 0 and/or 1) or V_{sys} supply inputs. In addition, there is V5V supply pin, which sources the V_{CONN} supply to the Type-C connector, the valid levels on V5V supply can range from 4.85 V–5.5 V. V5V does not power the chip. The chip’s internal operating power supply is derived from V_{sys} (2.75 V–5.5 V) or VBUS (4 V–21.5 V). In dead battery mode, the chip can be supplied power from Type-C VBUS (from port 0 and/or 1). In UFP, DFP, and DRP modes (when the system battery is charged), the chip is powered via V_{sys}. CCG6DF and CCG6SF devices support power modes to minimize energy consumption when not actively involved in data communication over the Type-C port.

Figure 2 and **Figure 3** show an overview of the power system requirement for CCG6DF and CCG6SF devices. CCG6DF and CCG6SF devices have two different power modes: Active and Deep Sleep, transitions between which are managed by the power system. A separate power domain, V_{DDIO}, is provided for the GPIOs and V_{DD} which generates 3.3 V from internal regulator. V_{DD} can be shorted to V_{DDIO}. V_{DD} and V_{CCD} are not recommended to be used as power supplies for other circuits on the system. Also, V_{DD} and V_{CCD} pins cannot be treated as power sources for the chip. The V_{CCD} pin, the output of the core (1.8 V) regulator, is brought out for connecting a 0.1-μF capacitor for the regulator stability only.

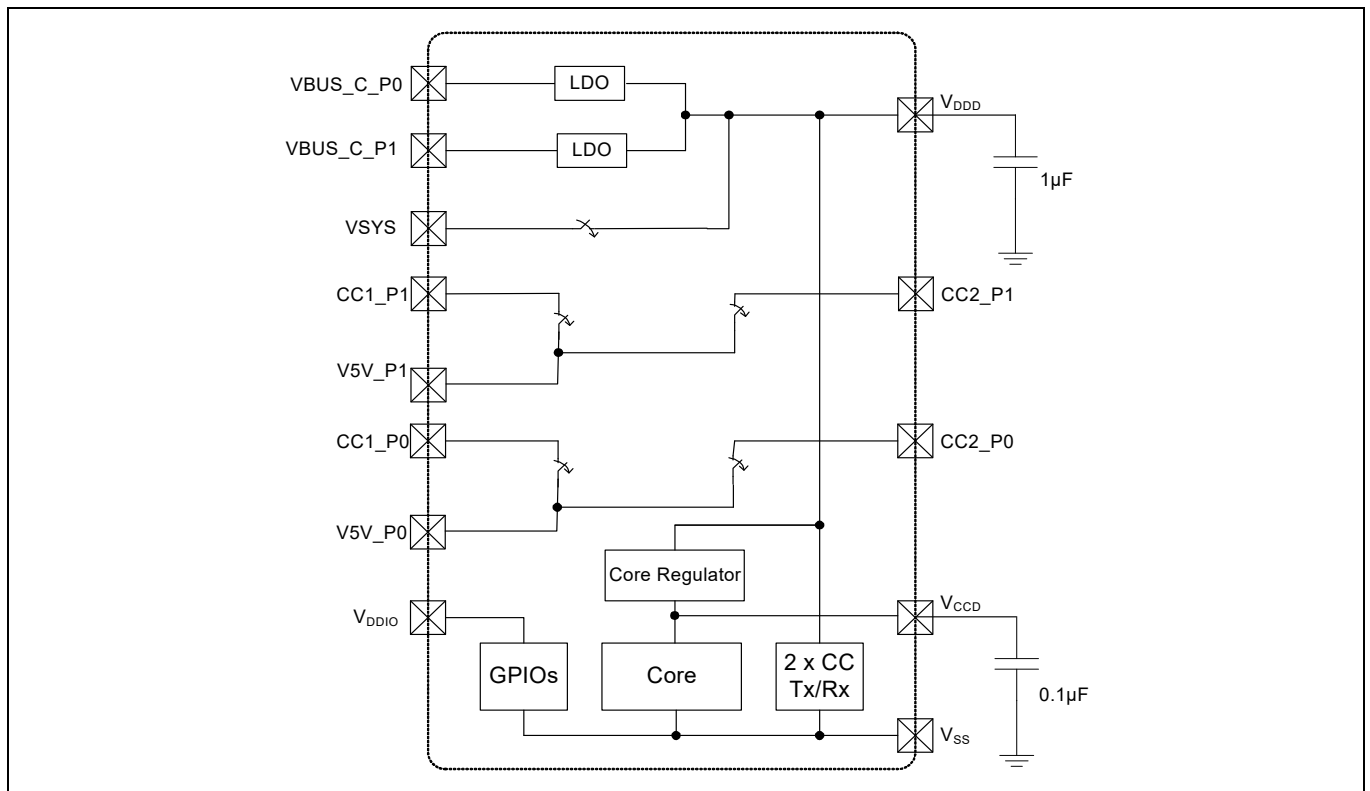

Figure 2 CCG6DF power supply requirement block diagram

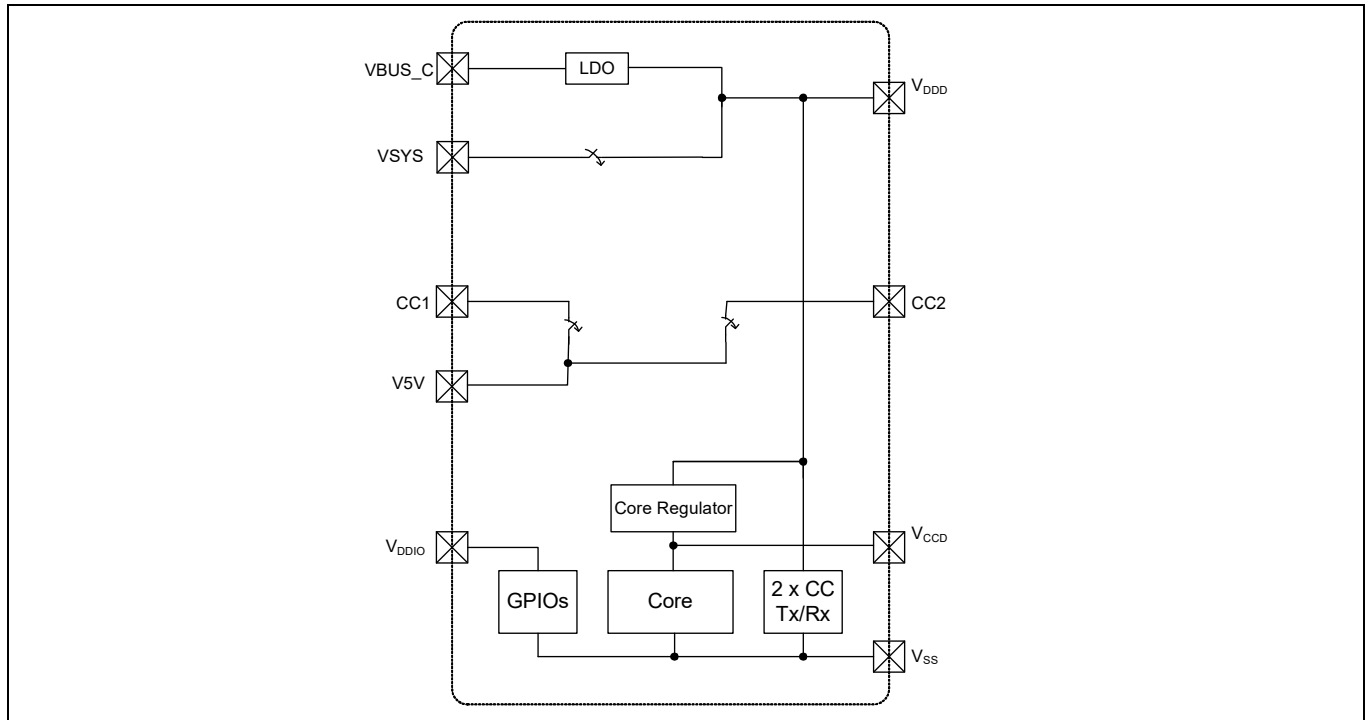

Figure 3 CCG6SF power supply requirement block diagram

Table 1 CCG6DF/CCG6SF power modes

Mode	Description
RESET	Power is valid and XRES is not asserted. An internal reset source is asserted or sleep controller is sequencing the system out of reset.
ACTIVE	Power is valid and CPU is executing instructions. This mode includes the critical Type-C power spec requirement.
DEEP SLEEP	Main regulator and most hard-IP are shut off. Deep Sleep regulator powers logic, but only low-frequency clock is available.

3 Pinouts

Table 2 Pinout for CYPD6227-96BZXI/CYPD6228-96BZXI

Group name	Pin name	Port	Pin	Description
USB Type-C	CC1_P0	Analog	B3	USB PD port-0 connector detect/ configuration channel 1
	CC2_P0	Analog	B5	USB PD port-0 connector detect/ configuration channel 2
	CC1_P1	Analog	K5	USB PD port-1 connector detect/ configuration channel 1
	CC2_P1	Analog	K3	USB PD port-1 connector detect/ configuration channel 2
Muxes/Switches	DP_SYS_P0	Analog	K11	USB 2.0 DP from the host system: port-0
	DM_SYS_P0	Analog	J11	USB 2.0 DM from the host system: port-0
	UART_TX_P0/P1.4	GPIO	H10	UART Tx from host system: port-0/GPIO
	UART_RX_P0/P1.3	GPIO	G10	UART Rx from host system: port-0/GPIO
	DP_BOT_P0	Analog	K10	USB 2.0 DP from bottom of Type-C connector: port-0
	DM_BOT_P0	Analog	J10	USB 2.0 DM from bottom of Type-C connector: port-0
	DM_TOP_P0	Analog	H11	USB 2.0 DM from top of Type-C connector: port-0
	DP_TOP_P0	Analog	G11	USB 2.0 DP from Top of Type-C connector: port-0
	SBU2_P0	Analog	A4	Type-C sideband use signal – connector side: port-0
	SBU1_P0	Analog	A5	Type-C sideband use signal – connector side: port-0
	SBU1_SYS_P0	Analog	B6	Type-C sideband use signal – system side: port-0
	SBU2_SYS_P0	Analog	A6	Type-C sideband use signal – system side: port-0
	DP_SYS_P1	Analog	L6	USB 2.0 DP from the host system: port-1
	DM_SYS_P1	Analog	L5	USB 2.0 DM from the host system: port-1
	UART_TX_P1/P0.0	GPIO	L4	UART Tx from host system: port-1/GPIO
	UART_RX_P1/P0.1	GPIO	K6	UART Rx from host system: port-1/GPIO
	DP_BOT_P1	Analog	K8	USB 2.0 DP from bottom of Type-C connector: port-1
	DM_BOT_P1	Analog	K7	USB 2.0 DM from bottom of Type-C connector port-1
	DM_TOP_P1	Analog	L7	USB 2.0 DM from top of Type-C connector: port-1
	DP_TOP_P1	Analog	L8	USB 2.0 DP from top of Type-C connector: port-1
SBU2_P1	Analog	A9	Type-C sideband use signal – connector side: port-1	
SBU1_P1	Analog	A8	Type-C sideband use signal – connector side port-1	
SBU1_SYS_P1	Analog	B7	Type-C sideband use signal – system side: port-1	
SBU2_SYS_P1	Analog	A7	Type-C sideband use signal – system side: port-1	

Pinouts

Table 2 Pinout for CYPD6227-96BZXI/CYPD6228-96BZXI (continued)

Group name	Pin name	Port	Pin	Description
VBUS Control	VBUS_C_CTRL_P0	Analog	A3	Full rail control I/O for enabling/disabling consumer load NFET of USB Type-C port-0
	VBUS_C_CTRL_P1	Analog	L3	Full rail control I/O for enabling/disabling consumer load NFET of USB Type-C port-1
VBUS OCP	CSP_P0	Analog	A11	Current sense positive input for VBUS side external Rsense: port-0
	CSN_P0	Analog	A10	Current sense negative input for other side of external Rsense: port-0
	CSP_P1	Analog	L11	Current sense positive input for VBUS side external Rsense: port-1
	CSN_P1	Analog	L10	Current sense negative input for other side of external Rsense: port-1
GPIOs and Serial Interfaces	I2C_SDA_SCB1/P0.2	GPIO	K9	SCB1 data for communicating with SoC or TBT controller/GPIO
	I2C_SCL_SCB1/P0.3	GPIO	H7	SCB1 clock for communicating with SoC or TBT controller/GPIO
	I2C_INT_EC/P1.2	GPIO	F11	Embedded controller interrupt/GPIO
	P2.4	GPIO	D10	GPIO
	I2C_INT_TBT_P0/P0.4	GPIO	L9	Thunderbolt interrupt for port-0/GPIO
	SWD_IO/P1.1	GPIO	G8	Serial wire debug I/O/GPIO
	SWD_CLK/P1.0	GPIO	F10	Serial wire debug clock/GPIO
	HPD_P0/P2.0	GPIO	F8	Hot plug detect I/O for port-0/GPIO
	I2C_SDA_SCB2/P2.1	GPIO	E11	SCB2 data for configuring re-timer or DP/USB multi-function MUX/GPIO
	I2C_SCL_SCB2/P2.2	GPIO	E10	SCB2 clock for configuring re-timer or DP/USB multi-function MUX/GPIO
	P2.3	GPIO	E8	GPIO
	I2C_INT_TBT_P1/P0.5	GPIO	H8	Thunderbolt interrupt for port-1/GPIO
	P2.5	GPIO	D8	GPIO
	I2C_SCL_SCB0/P4.0	GPIO	D11	SCB0 clock for communicating with embedded controller/GPIO
	I2C_SDA_SCB0/P4.1	GPIO	C11	SCB0 data for communicating with embedded controller/GPIO
	P3.0	GPIO	B10	GPIO
	I2C_SDA_SCB3/P3.1	GPIO	B11	SCB3 data/GPIO
I2C_SCL_SCB3/P3.2	GPIO	B9	SCB3 clock/GPIO	
HPD_P1/P3.3	GPIO	B8	Hot plug detect I/O for port-1/GPIO	
Reset	XRES	Analog	C10	Reset input

Pinouts

Table 2 Pinout for CYPD6227-96BZXI/CYPD6228-96BZXI (continued)

Group name	Pin name	Port	Pin	Description
Power	VBUS_C_P0	Power	A1, A2, B1, B2, C1	Type-C VBUS connector input for port-0 (4-V to 21.5-V)
	VBUS_C_P1	Power	J1, K1, K2, L1, L2	Type-C VBUS connector input for port-1 (4-V to 21.5-V)
	VBUS_P_P0	Power	C2, D1, D2, E1, E2	VBUS provider input for port-0 (4-V to 5.5-V)
	VBUS_P_P1	Power	G1, G2, H1, H2, J2	VBUS provider input for port-1 (4-V to 5.5-V)
	VSYS	Power	F4	2.75-V to 5.5-V supply for the system
	VDDD	Power	G7	VDDD supply output 1. VSYS powered - (Min: VSYS-50 mV) 2.7 V to 5.5 V 2. VBUS powered - 3.0 V to 3.6 V
	VDDIO	Power	F7	At system-level short the VDDD to VDDIO
	VCCD	Power	E7	1.8-V regulator output for filter capacitor. This pin cannot drive external load.
	V5V_P0	Power	B4	4.85-V to 5.5-V supply for VCONN FET of Type-C: port-0
	V5V_P1	Power	K4	4.85-V to 5.5-V supply for VCONN FET of Type-C: port-1
Ground	VSSD	Ground	D7, E5, E6, F1, F2, F5, F6, G4, G5, G6	Ground

Pinouts

	1	2	3	4	5	6	7	8	9	10	11
A	VBUS_C_P0	VBUS_C_P0	VBUS_C_CTRL_P0	SBU2_P0	SBU1_P0	SBU2_SYS_P0	SBU2_SYS_P1	U1_P1	SBU2_P1	CSN_P0	CSP_P0
B	VBUS_C_P0	VBUS_C_P0	CC1_P0	V5V_P0	CC2_P0	SBU1_SYS_P0	SBU1_SYS_P1	HPD_P1/P3.3	I2C_SCL_SCB3/P3.2	P3.0	I2C_SDA_SCB3/P3.1
C	VBUS_C_P0	VBUS_P_P0								XRES	I2C_SDA_SCB0/P4.1
D	VBUS_P_P0	VBUS_P_P0			DNU	DNU		P2.5		P2.4	I2C_SCL_SCB0/P4.0
E	VBUS_P_P0	VBUS_P_P0		DNU			VCCD	P2.3		I2C_SCL_SCB2/P2.2	I2C_SDA_SCB2/P2.1
F				VSYS			VDDIO	HPD_P0/P2.0		SWD_CLK/P1.0	I2C_INT_EC/P1.2
G	VBUS_P_P1	VBUS_P_P1					VDDD	SWD_IO/P1.1		UART_RX_P0/P1.3	DP_TOP_P0
H	VBUS_P_P1	VBUS_P_P1		DNU	DNU	DNU	I2C_SCL_SCB1/P0.3	I2C_INT_TBT_P1/P0.5		UART_TX_P0/P1.4	DM_TOP_P0
J	VBUS_C_P1	VBUS_P_P1								DM_BOT_P0	DM_SYS_P0
K	VBUS_C_P1	VBUS_C_P1	CC2_P1	V5V_P1	CC1_P1	UART_RX_P1/P0.1	DM_BOT_P1	DP_BOT_P1	I2C_SDA_SCB1/P0.2	DP_BOT_P0	DP_SYS_P0
L	VBUS_C_P1	VBUS_C_P1	VBUS_C_CTRL_P1	UART_TX_P1/P0.0	DM_SYS_P1	DP_SYS_P1	DM_TOP_P1	DP_TOP_P1	I2C_INT_TBT_P0/P0.4	CSN_P1	CSP_P1

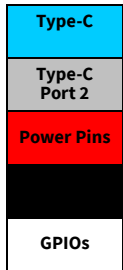

Figure 4 96-ball BGA pin map (top view) for CYPD6227-96BZXI/CYPD6228-96BZXI

Pinouts

Table 3 Pinout for CYPD6127-48LQXI/CYPD6128-48LQXI

Group name	Pin name	Port	Pin	Description
USB Type-C	CC1	Analog	46	USB PD connector detect/ configuration channel 1
	CC2	Analog	44	USB PD connector detect/ configuration channel 2
Mux	DP_SYS	Analog	23	USB 2.0 DP from the host system
	DM_SYS	Analog	22	USB 2.0 DM from the host system
	UART_TX/P1.4	GPIO	24	UART Tx from host system/GPIO
	UART_RX/P1.3	GPIO	25	UART Rx from host system/GPIO
	DP_BOT	Analog	20	USB 2.0 DP from bottom of Type-C connector
	DM_BOT	Analog	21	USB 2.0 DM from bottom of Type-C connector
	DM_TOP	Analog	19	USB 2.0 DM from top of Type-C connector
	DP_TOP	Analog	18	USB 2.0 DP from top of Type-C connector
	SBU2	Analog	43	Type-C sideband use signal – connector side
	SBU1	Analog	42	Type-C sideband use signal – connector side
	SBU1_SYS	Analog	41	Type-C sideband use signal – system side
	SBU2_SYS	Analog	40	Type-C sideband use signal – system side
VBUS Control	VBUS_C_CTRL	Analog	47	Full rail control I/O for enabling/disabling consumer load NFET of USB Type-C
VBUS OCP	CSP	Analog	39	Current sense positive input for VBUS side external Rsense
	CSN	Analog	38	Current sense negative input for other side of external Rsense

Pinouts

Table 3 Pinout for CYPD6127-48LQXI/CYPD6128-48LQXI (continued)

Group name	Pin name	Port	Pin	Description
GPIOs and Serial Interfaces	I2C_SDA_SCB1/P0.2	GPIO	16	SCB1 data/GPIO
	I2C_SCL_SCB1/P0.3	GPIO	13	SCB1 clock/GPIO
	I2C_INT_TBT/P0.4	GPIO	17	Thunderbolt interrupt/GPIO
	I2C_INT_EC/P1.2	GPIO	26	Embedded controller interrupt/GPIO
	SWD_IO/P1.1	GPIO	14	Serial wire debug I/O/GPIO
	SWD_CLK/P1.0	GPIO	15	Serial wire debug clock/GPIO
	HPD/P2.0	GPIO	27	Hot plug detect I/O/GPIO
	I2C_SDA_SCB2/P2.1	GPIO	28	SCB2 data/GPIO
	I2C_SCL_SCB2/P2.2	GPIO	29	SCB2 clock/GPIO
	P2.3	GPIO	30	GPIO
	P2.4	GPIO	31	GPIO
	I2C_SCL_SCB0/P4.0	GPIO	32	SCB0 clock/GPIO
	I2C_SDA_SCB0/P4.1	GPIO	33	SCB0 data/GPIO
	P3.0	GPIO	35	GPIO
	I2C_SDA_SCB3/P3.1	GPIO	36	GPIO
	I2C_SCL_SCB3/P3.2	GPIO	37	GPIO
P3.3	GPIO	12	GPIO	
Reset	XRES	Analog	34	Reset input
Power	VBUS_C	Power	1, 2, 3, 48	Type-C VBUS connector input (4-V to 21.5-V)
	VBUS_P	Power	4, 5, 6, 7	VBUS provider input (4-V to 5.5-V)
	VSYS	Power	8	2.75-V to 5.5-V supply for the system
	VDDD	Power	11	VDDD supply output 1. VSYS powered - (Min: VSYS – 50 mV) 2.7 V to 5.5 V 2. VBUS powered - 3.0 V to 3.6 V
	VDDIO	Power	10	At system-level short the VDDD to VDDIO
	VCCD	Power	9	1.8-V regulator output for filter capacitor. This pin cannot drive external load.
Ground	V5V	Power	45	4.85-V to 5.5-V supply for VCONN FET of Type-C
	–	Ground	EPAD	Ground

Pinouts

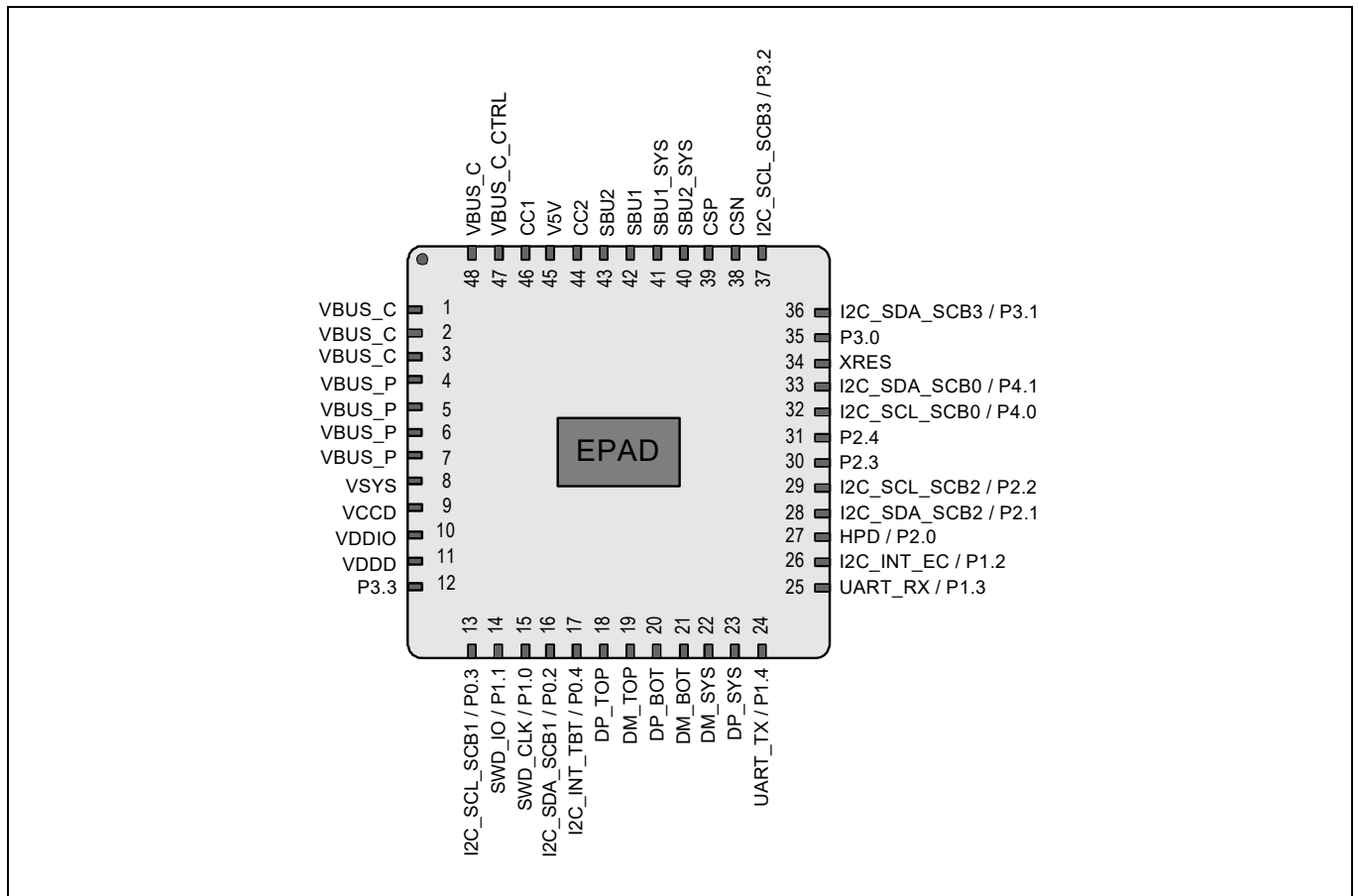

Figure 5 48-pin QFN pin map for CYPD6127-48LQXI/CYPD6128-48LQXI

4 Application diagrams

The CCG6DF device communicates with the embedded controller (EC), which manages the battery charger controller (BCC) to control the charging and discharging of the internal battery. It also updates the Thunderbolt Controller via I²C to route the HighSpeed signals coming from the Type-C port to the USB host (during normal mode) or the graphics processor unit (during DisplayPort Alternate mode) or the Thunderbolt host (during Thunderbolt Alternate mode) based on the alternate mode negotiation.

The CCG6DF device controls the transfer of USB 2.0 DP and DM lines from the top and bottom of the Type-C receptacle to the DP and DM lines of the USB host controller. CCG6DF offers VBUS short protection on SBU and CC lines.

The CCG6DF device has integrated VCONN FETs for applications that need to provide power for accessories and cables using the VCONN pin of the Type-C receptacle. The 5-mΩ resistor between the 5-V supply and the integrated provider FETs is used for overcurrent detection on the VBUS.

Application diagrams

Figure 6 illustrates a dual port Thunderbolt notebook DRP application diagram using CYPD6227-96BZXI/ CYPD6228-96BZXI.

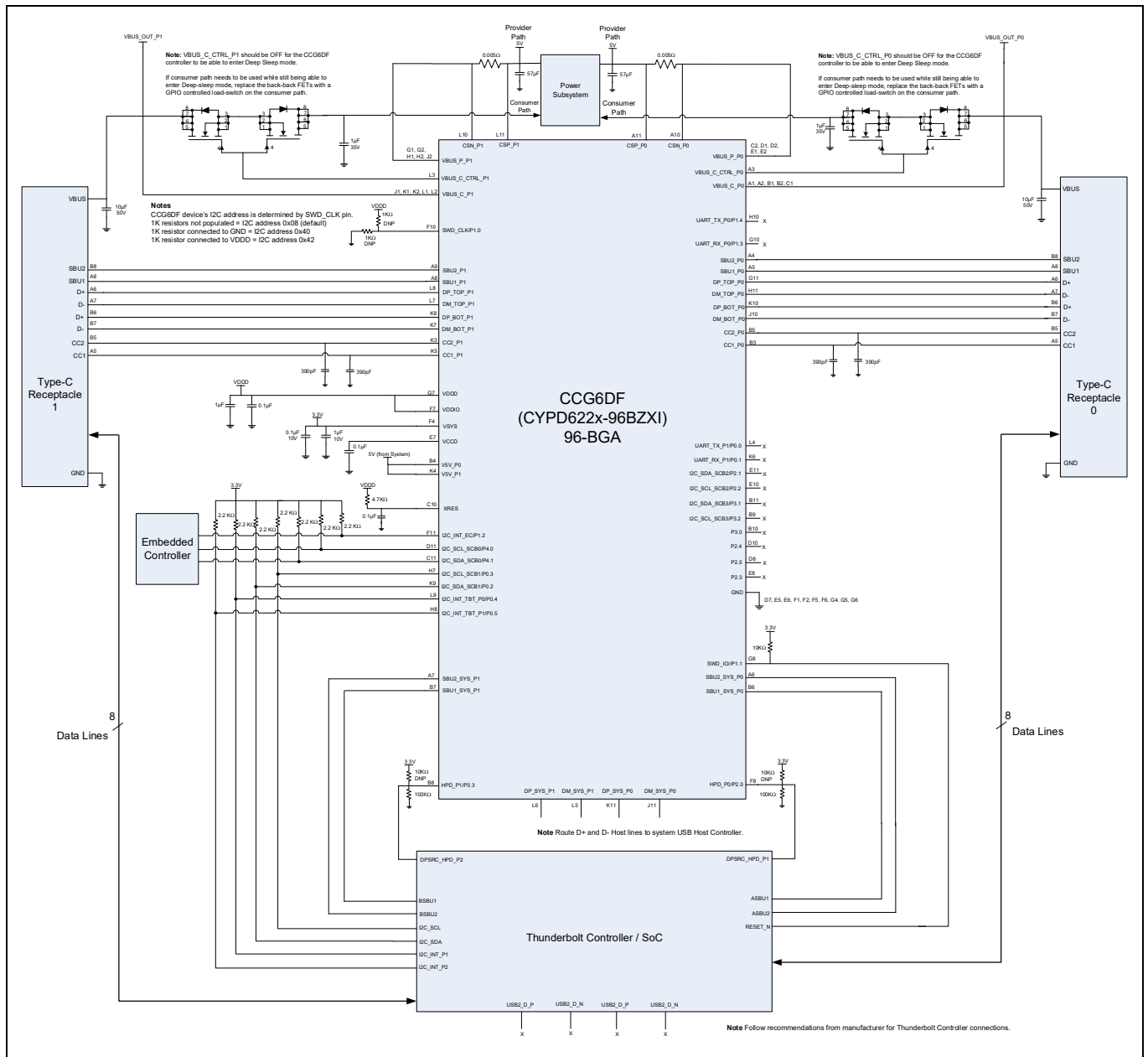

Figure 6 CCG6DF 96-ball BGA dual port Thunderbolt notebook application diagram

Application diagrams

Figure 7 illustrates a single-port Thunderbolt notebook DRP application diagram using CYPD6127-48LQXI/CYPD6128-48LQXI.

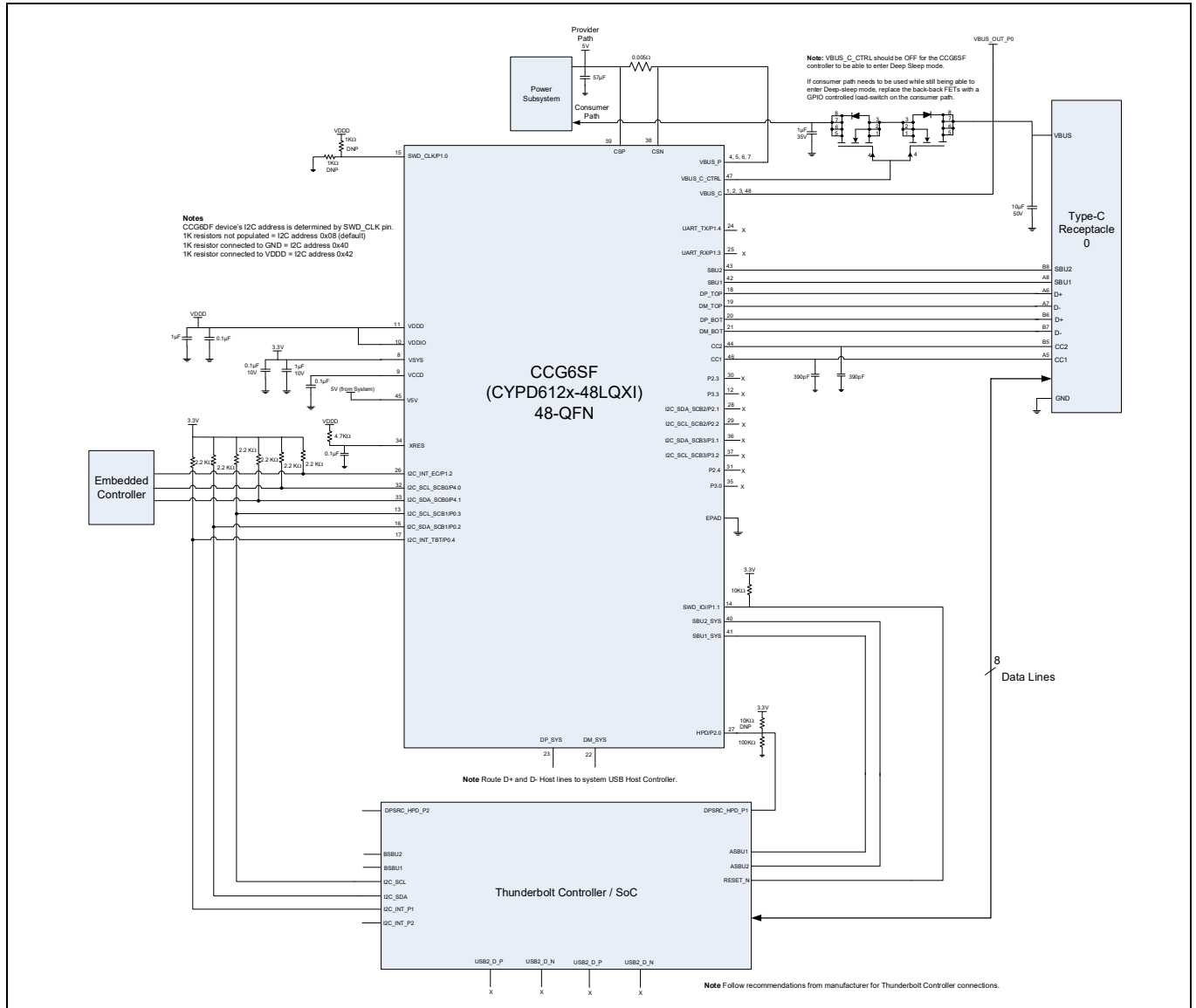

Figure 7 CCG6SF 48-pin QFN single port Thunderbolt notebook application diagram

5 CCG6DF layout design guidelines for BGA package

Proper routing and placement help to maintain signal integrity for high-speed signals, improve thermal dissipation and reduce power consumption for CCG6DF/SF. The combination of power and high-speed data signals can be better routed if these design guidelines are followed. It is highly recommended to consult with a PCB manufacturer to verify the manufacturing capabilities to propose the right design guidelines. This section provides layout recommendations which are applicable to both CCG6DF and CCG6SF devices.

Figure 8 shows the CCG6DF 96-BGA device footprint that is recommended. The footprint has oval-shaped pads in specific locations. It is recommended to use oval pads in order to reduce the manufacturing cost by eliminating a high density Interconnector (HDI) board processing. This method allows the PCB designer to route the inner perimeter balls through the top layer. The balls around the perimeter have their pads in an oval shape with the exception of the corner balls. This footprint is recommended for MDI (medium density) PCB designs that are generally less expensive to build.

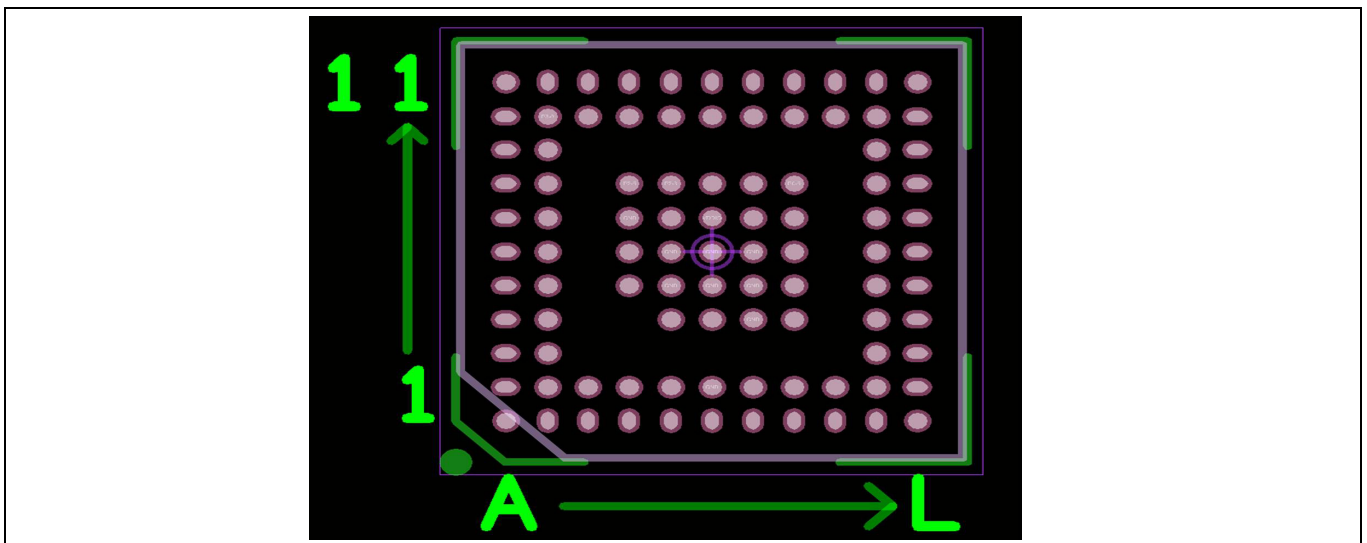

Figure 8 Top view standard footprint (recommended) for CCG6DF, CCG6SF 96-BGA

5.1 Usage of via size of 8-mil drill/16-mil diameter and 10-mil drill/16-mil diameter

In order to use larger via size of 8/16 (8-mil drill and 16-mil diameter) or 10/16 (10-mil drill and 16-mil diameter), one GPIO (BGA pad D8) is unusable and should be left unconnected. This would free up space underneath the package. This is a critical factor that helps to decide the minimum drill size for the vias. Two different pad sizes for the BGA balls are recommended for better yield in terms of assembly. Note that if GPIO pad D8 cannot be freed up, 6 mil hole/12 mil diameter via sizes can be used to do PCB trace routing.

Via size of greater than 10-mil drill and 16-mil diameter is not feasible for inner BGA pads. Drill hole size of greater than 10-mils overlaps with the BGA pads and may result in “cold solder” during SMT reflow. **Figure 9** shows the recommended 8/16 and 10/16 minimum via sizes (8-mil drill and 16-mil diameter).

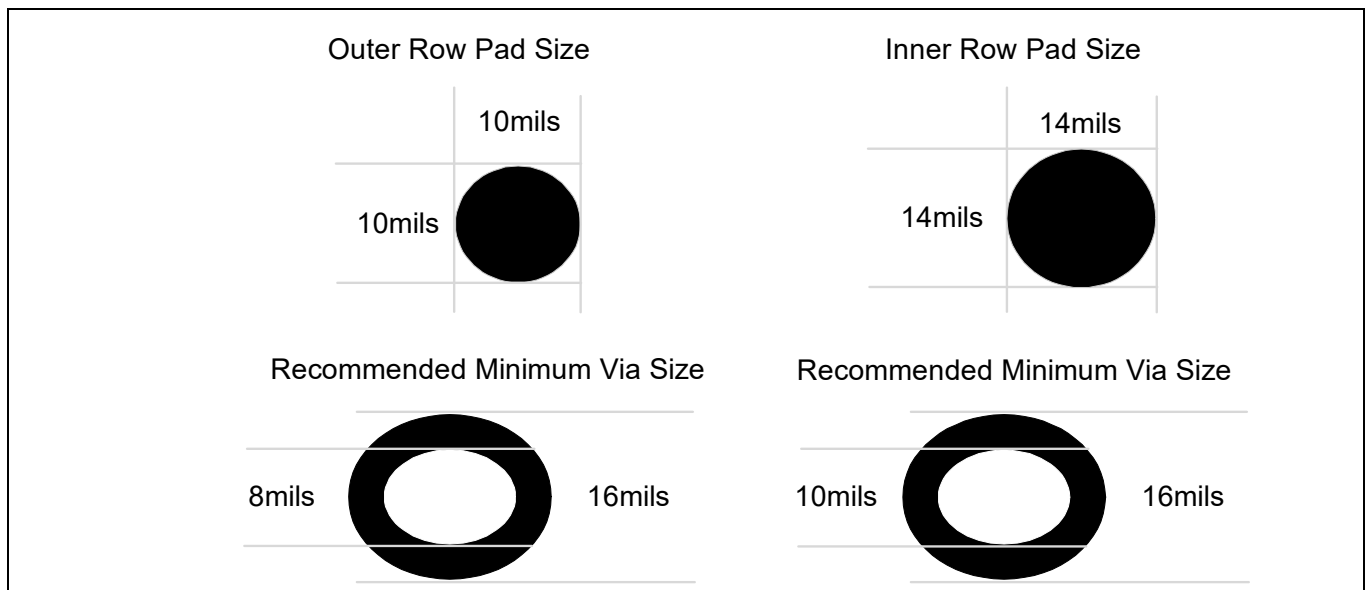

Figure 9 Recommended pad size and via size (8/16 and 10/16)

5.1.1 Layer stack-up

A typical 8-layer stack-up with 1 oz of copper is shown in **Figure 10**.

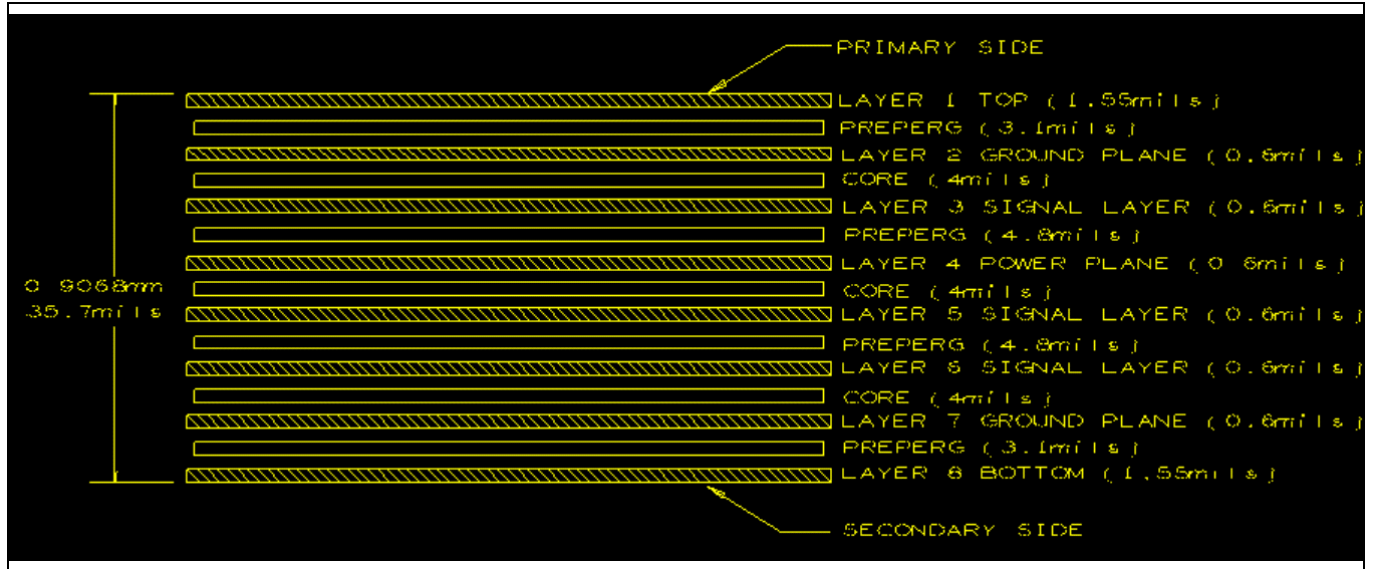

Figure 10 Eight layer stack-up

5.1.2 Top layer fanout

Figure 11 shows a method of routing inner BGA balls and fan-out method for the routing for 8/16 or 10/16 via sizes.

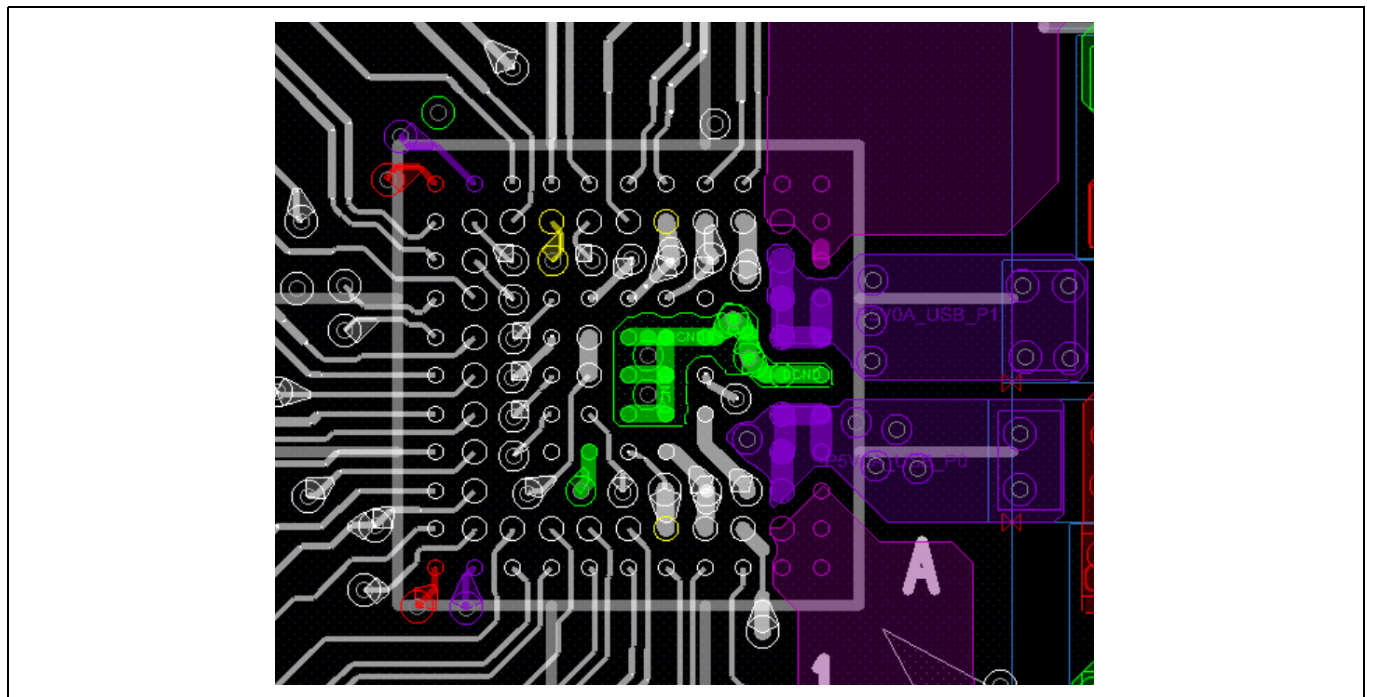

Figure 11 Top Layer Fanout (8/16 or 10/16 via sizes)

5.1.3 Via count for GND pads

Each via has a thermal resistance of 219°C/W. Adding three such vias will help reducing thermal resistance to 73°C/W and would help to distribute the heat better. As shown in **Figure 12**, it is recommended to short the 6 GND pads with a small split plane on the top layer and have a minimum of two vias to meet the thermal performance. Elevated temperature of more than 100°C on BGA top may be observed if the via count is lesser than recommended. It is also recommended to have one via on GND pad (D7) with a trace width of 7 mils.

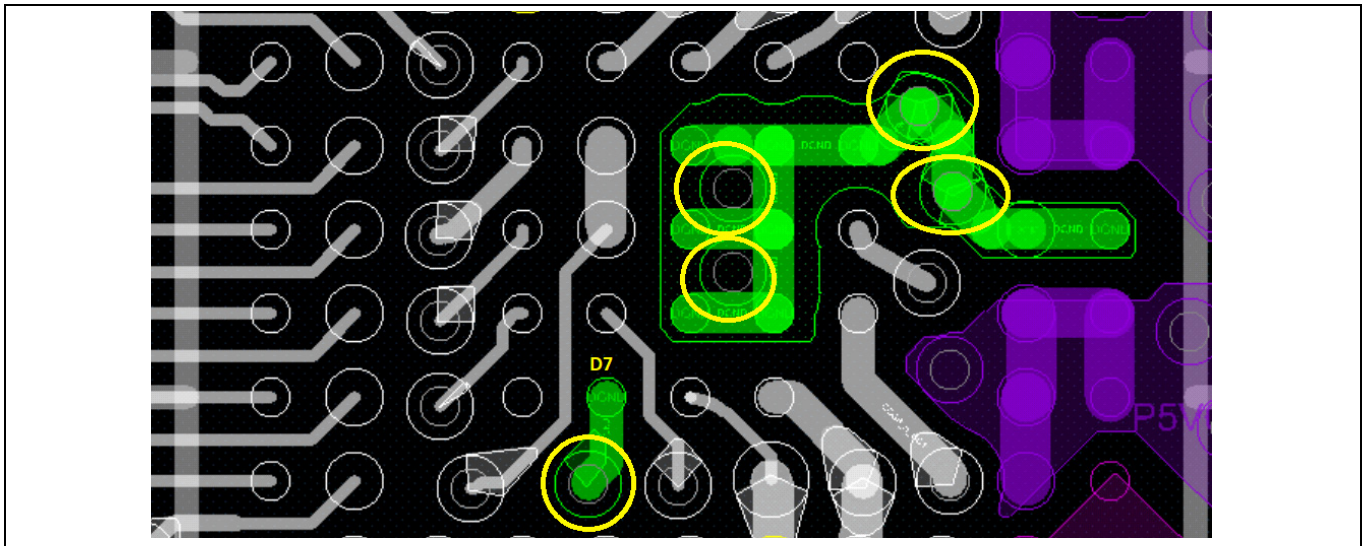

Figure 12 Via count for GND pads (8/16 or 10/16 via sizes)

5.1.4 Via count for provider pads

As shown in **Figure 13**, it is recommended to create a copper pour around the 5 provider pads on the top and bottom layers with minimum of 7 vias. It is also recommended to split the power plane on other layer to meet the thermal performance. These vias play a crucial role in dissipating the heat better.

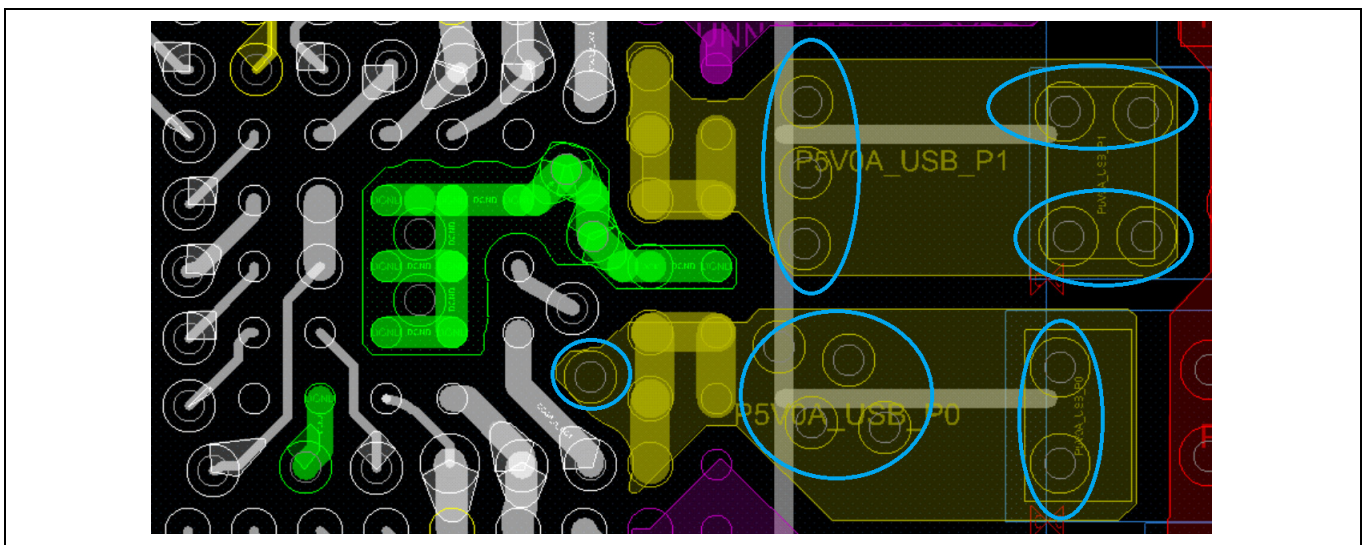

Figure 13 Via count for provider pads (8/16 or 10/16 via sizes)

5.1.5 High-speed (DP_SYS, DM_SYS) USB connections

The traces of DP and DM lines with via size of 8-mil drill, 16-mil diameter and 10-mil drill, 16-mil diameter are shown in **Figure 14**.

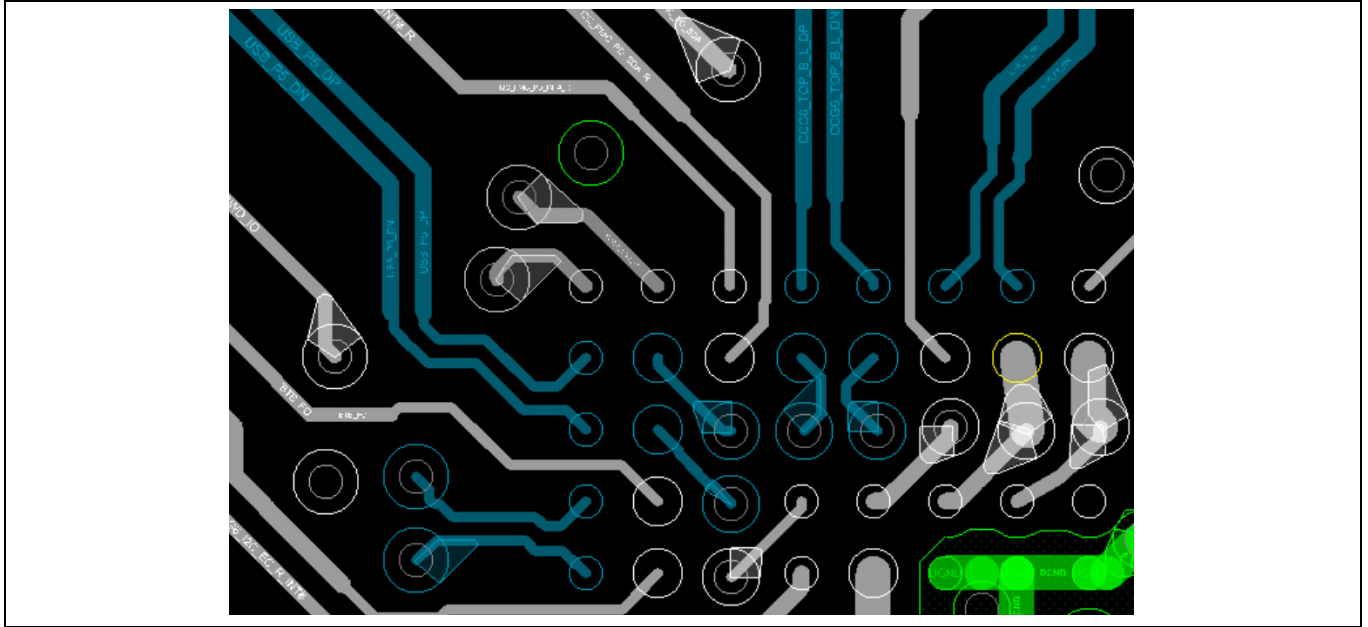

Figure 14 DP/DM Traces (8/16 or 10/16 via sizes)

5.1.6 Rsense and capacitor connections for provider VBUS

It is always advisable to keep the sense resistor (R_{sense}) close to CCG6DF/CCG6SF as it has internal VBUS provider switch. Connection from the regulator to R_{sense} should be done using big copper shape (pour) for carrying high currents.

The longer the trace length between components, the higher the voltage drop between components. The additional resistance reduces efficiency of the system. The resistance of trace can be calculated from below equation.

$$R_{trace} = \rho \times \frac{Tracelength}{Tracewidth \times Tracethickness}$$

Where the bulk resistance ρ , of copper is $0.67 \mu\Omega/\text{in}$ or $1.7 \mu\Omega/\text{cm}$ at 25°C .

The differential signal from R_{sense} should be length matched. The capacitor for provider VBUS should be as close as possible to the R_{sense} and connected using copper shape. **Figure 15** and **Figure 16** show routing for R_{sense} .

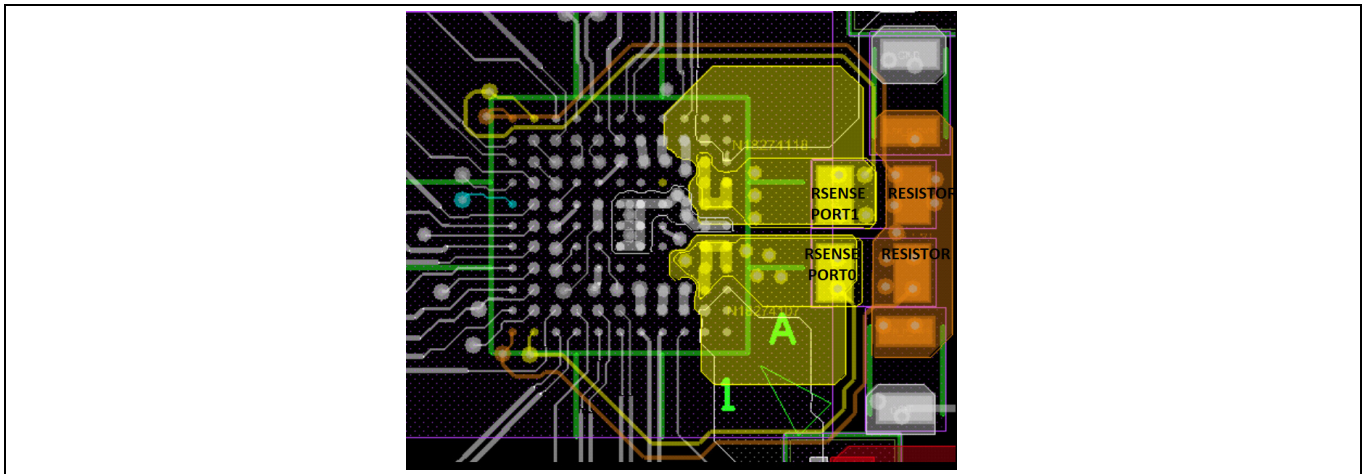

Figure 15 Rsense resistor placement (top layer)

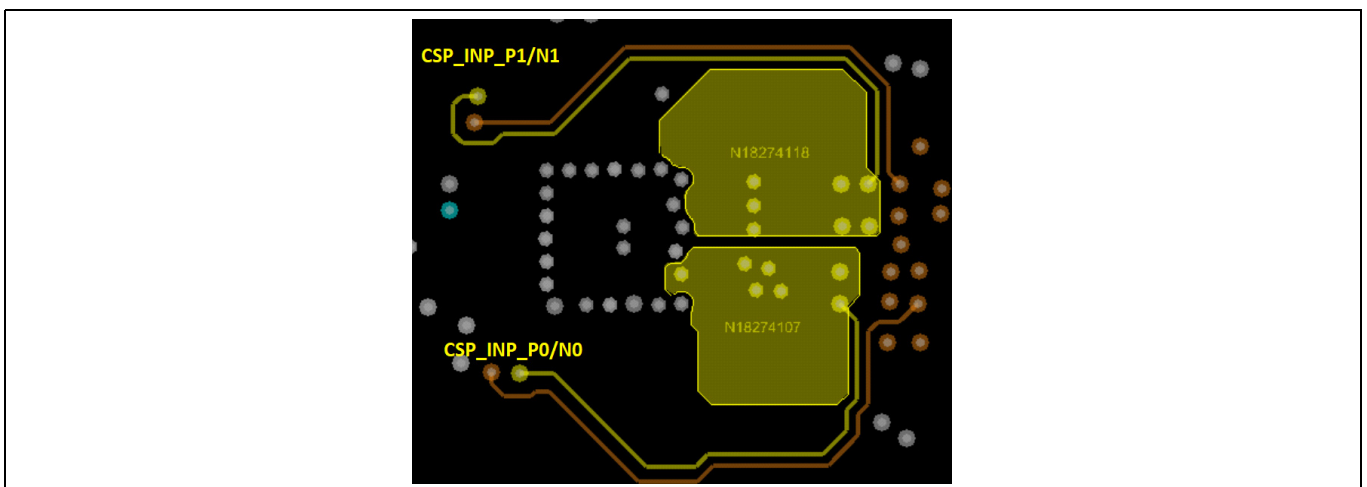

Figure 16 Rsense resistor trace routing with Kelvin connection (inner layer)

5.1.7 Trace width details for critical signals

Table 4 provides information on routing trace width for this layout example.

Table 4 Route trace width

Route	Route width (mils) (1-oz copper thickness)	Remarks/key feature/constraints
CC1, CC2	8	Current rating = 500 mA
GPIOs	5	-
DP/DM/Dsys	6 mils width/ 8mils spacing	90-Ω impedance signals
V _{DDIO}	10	Current rating = 15 mA
V _{DDD}		Current rating = 20 mA
V _{CCD}		
V _{SYS}		
V5V		Current rating = 500 mA

5.1.8 V_{DDIO} , V_{CCD} , V_{SYS} , and V_{DDD} connections

Figure 17 and Figure 18 show how the V_{DDIO} , V_{DDD} , V_{SYS} , and V_{CCD} signals get routed amongst the top and bottom layers.

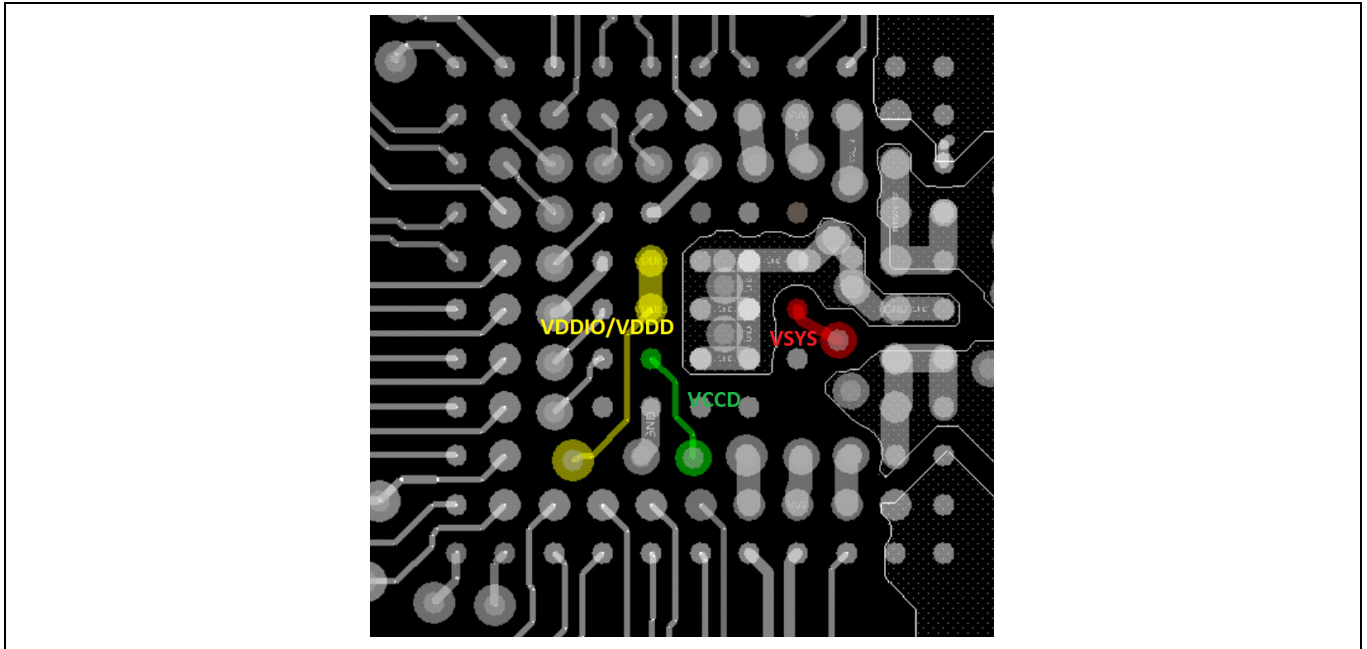

Figure 17 Top layer connection for V_{DDIO} , V_{DDD} , V_{SYS} and V_{CCD}

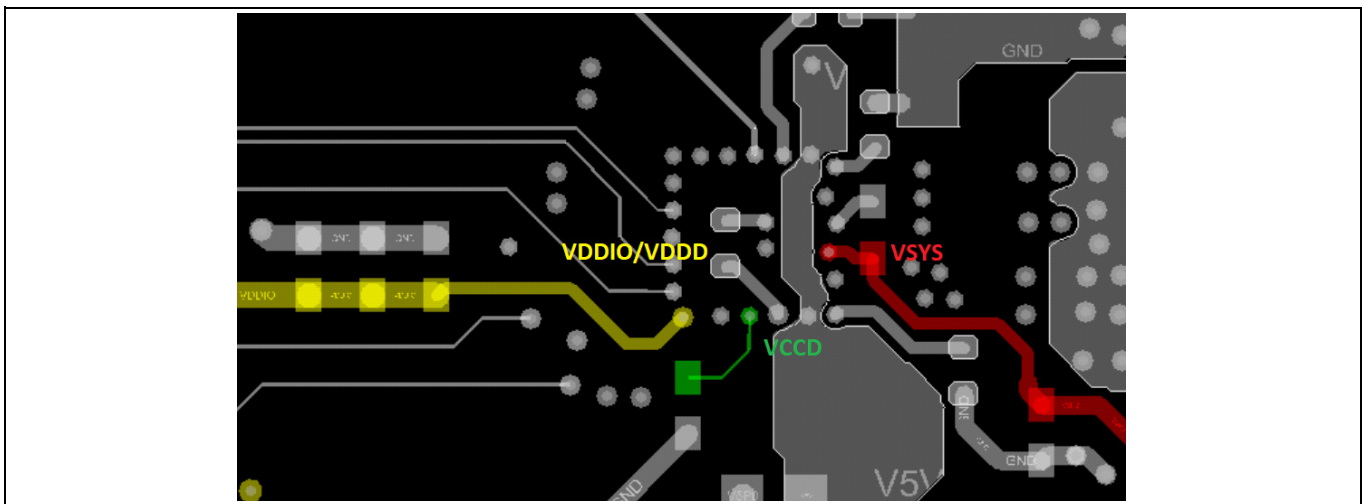

Figure 18 Bottom layer connection for V_{DDIO} , V_{DDD} , V_{SYS} and V_{CCD}

5.1.9 Capacitor connections for CC lines and bypass capacitors for V_{DDIO} , V_{DD} , V_{CCD} , and V_{SYS} pins

Figure 19 shows how the relevant capacitors can be placed for via sizes of 8-mil drill, 16-mil diameter or 10-mil drill, 16-mil diameter.

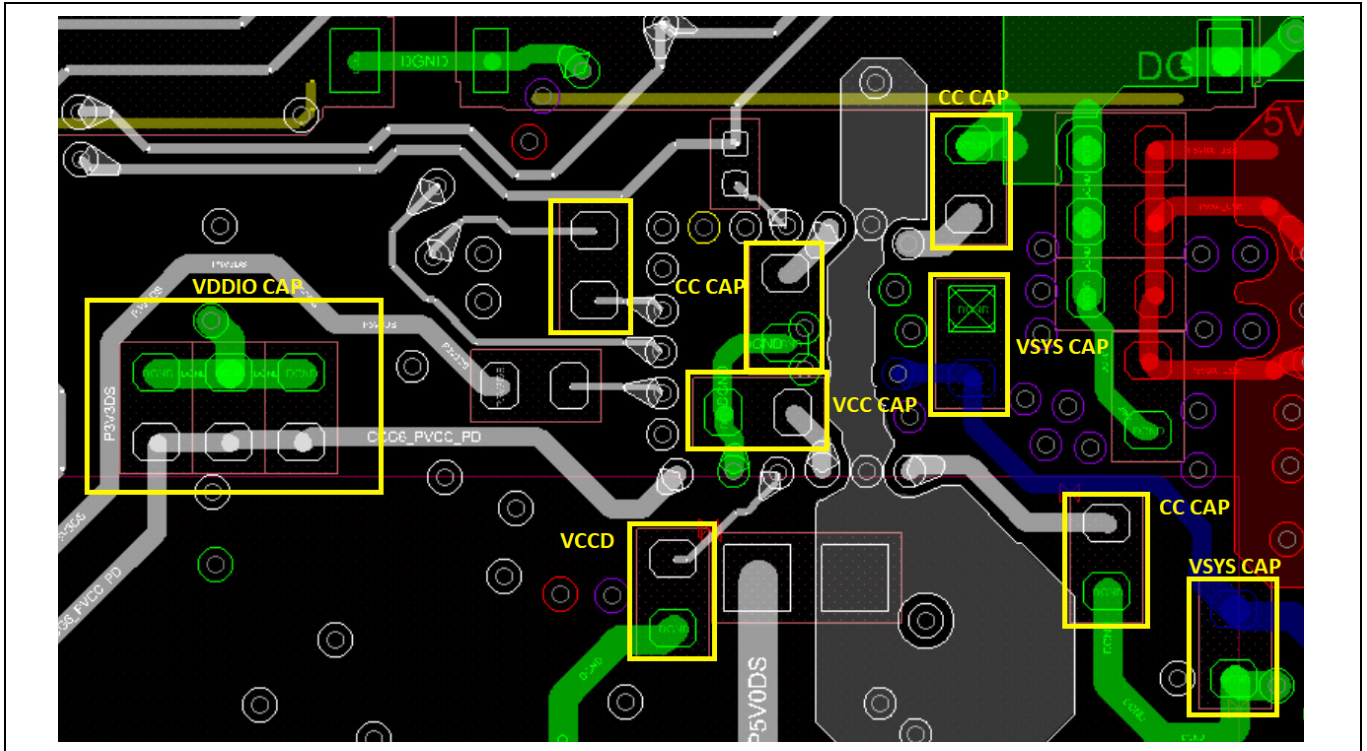

Figure 19 Capacitor connections (top and bottom layer placements for 8/16 or 10/16 via size)

6 CCG6SF layout design guidelines for 48-QFN package

Figure 20 shows the CCG6SF 48-QFN device footprint that is recommended. The footprint has rectangular shaped pads in all pins of this package. It is recommended to use rectangular pads to reduce the manufacturing cost by eliminating a HDI board processing.

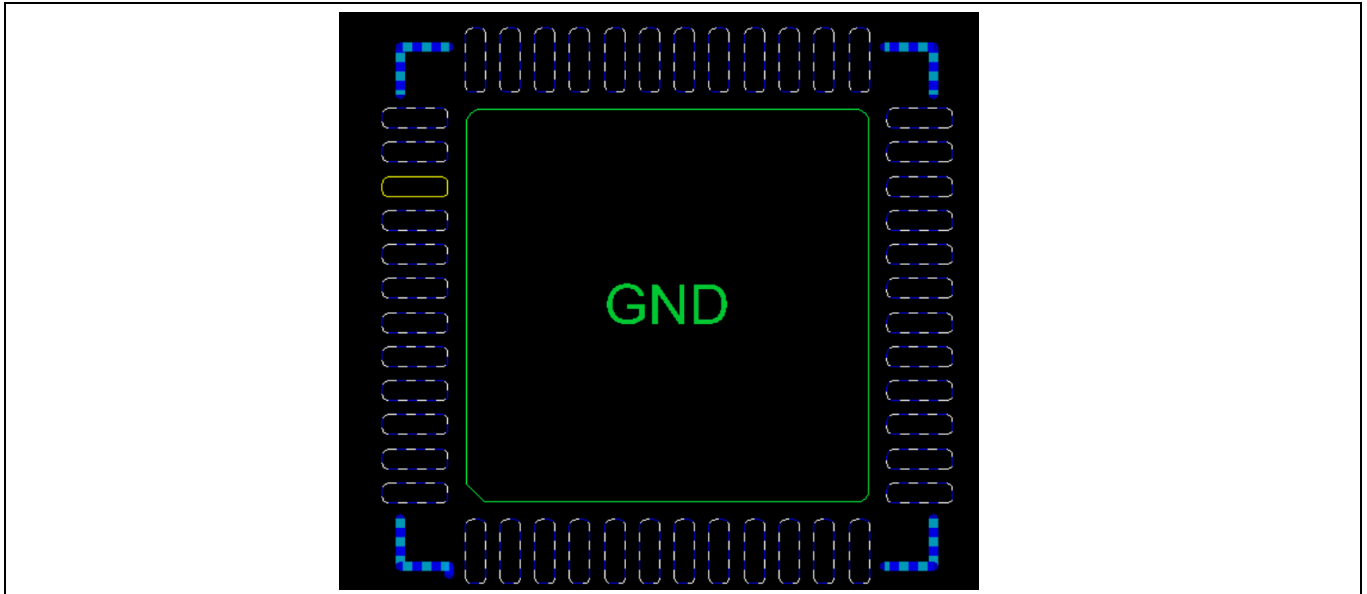

Figure 20 Top view standard footprint (recommended) for CCG6SF 48-QFN

6.1 Recommended pad size

Figure 21 is the recommended pad size for the QFN package.

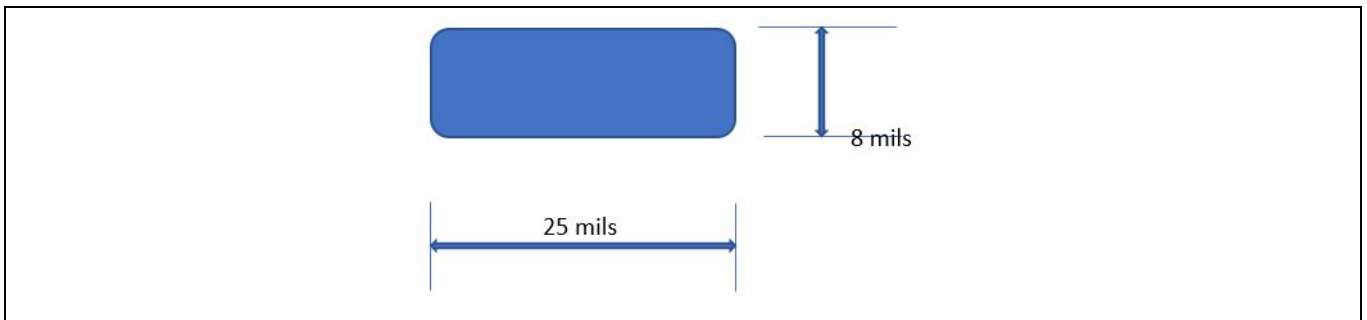

Figure 21 QFN pad size

6.2 Stack-up

Figure 22 shows a typical 6-layer stack-up with 1 oz of copper.

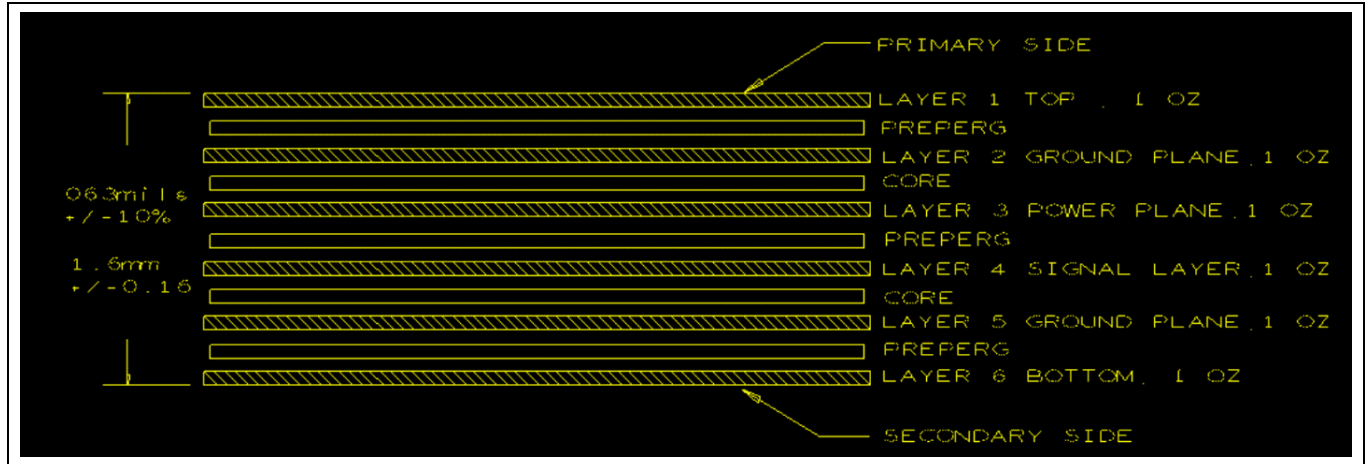

Figure 22 Six layer stack-up

6.3 48-QFN fanout

CCG6SF 48-QFN device uses 5 mil trace width for all the QFN pads and complies to MDI standards. It is better to use 5 mil trace on each of VBUS provider input (VBUS_P) pads and Type-C VBUS connector input (VBUS_C) pads and then connect with corresponding power shape. Otherwise, wider trace width would have non-solder mask between the pads and results in alignment issue during assembly.

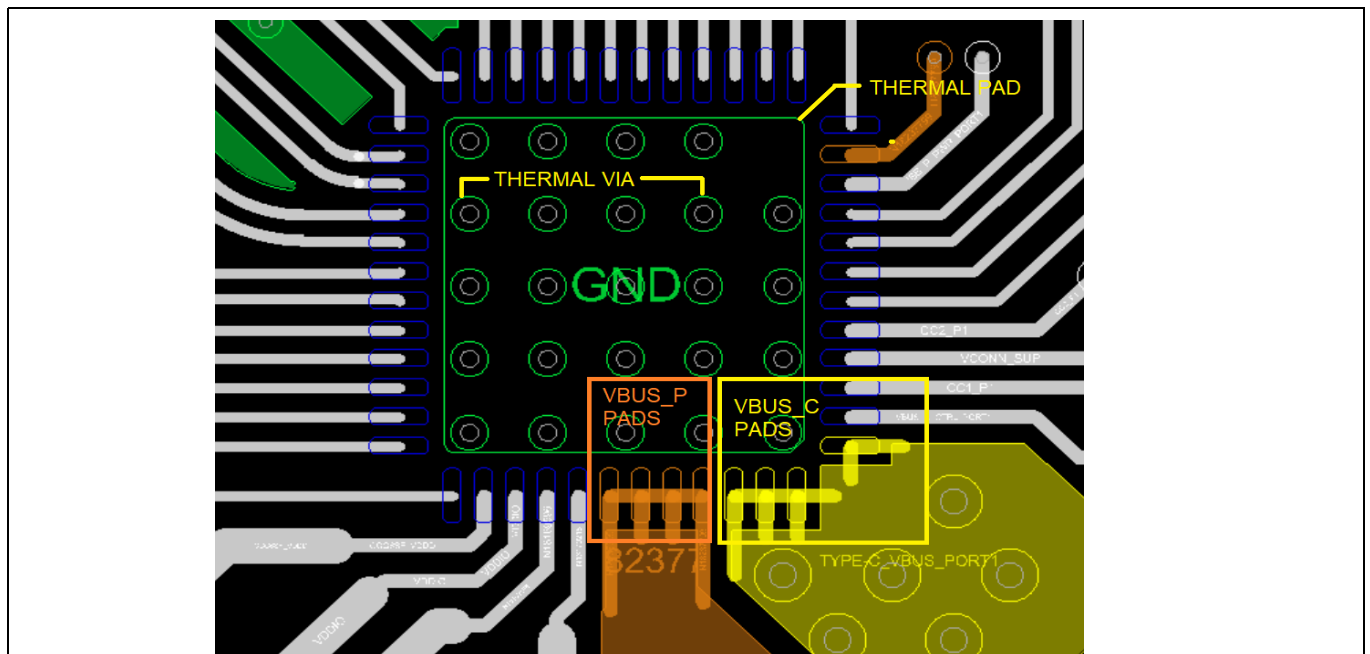

Figure 23 QFN fanout with thermal vias

6.4 Via count on thermal pads

As shown in **Figure 24**, CCG6SF 48-QFN device has 5 × 5 via array (25 vias) on the thermal pads. It is recommended to have minimum of 4 × 4 via array (16 vias) on the thermal pads to meet the thermal performance. Via array means number of vias present on row and column of the EPAD. Each via size should be minimum of 10 mil drill and 20 mil diameter. Each via has a thermal resistance of 179°C/W. Adding 4 × 4 vias will help reducing thermal resistance to (179/16 vias) 11°C/W and would help to distribute the heat better. Lesser the thermal resistance better the thermal performance. Power plane is required on this path to able to carry ~6 A of current.

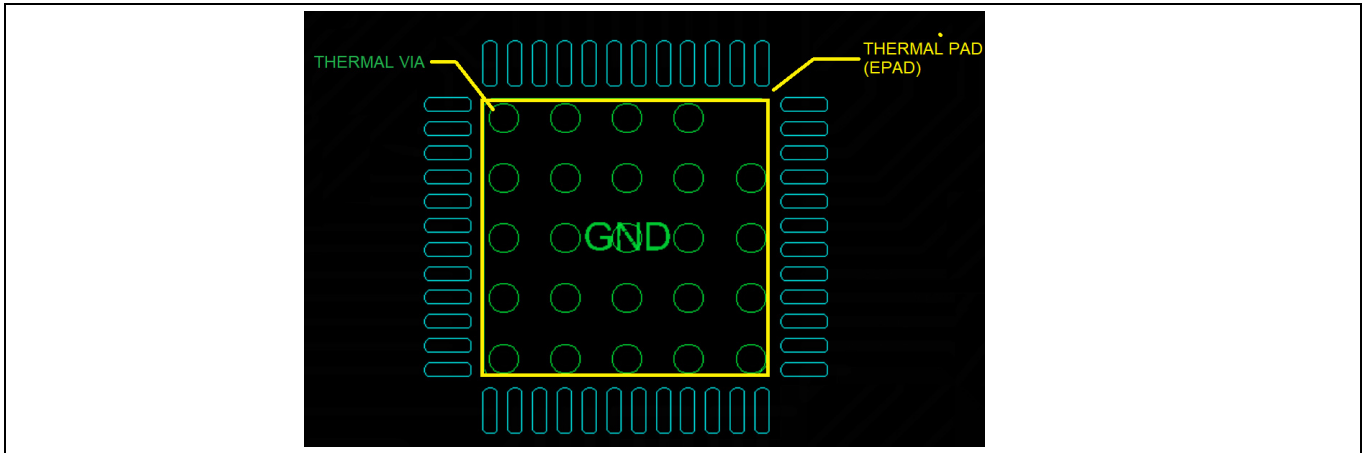

Figure 24 Thermal pad (EPAD) and thermal via

6.5 Via count for VBUS_P and VBUS_C pads

As shown in **Figure 25**, it is recommended to create a copper pour around the VBUS_P and VBUS_C pads on the top and bottom layers with minimum of 6 vias. It is also recommended to split the power plane on other layer to meet the thermal performance. These vias play a crucial role in dissipating the heat better.

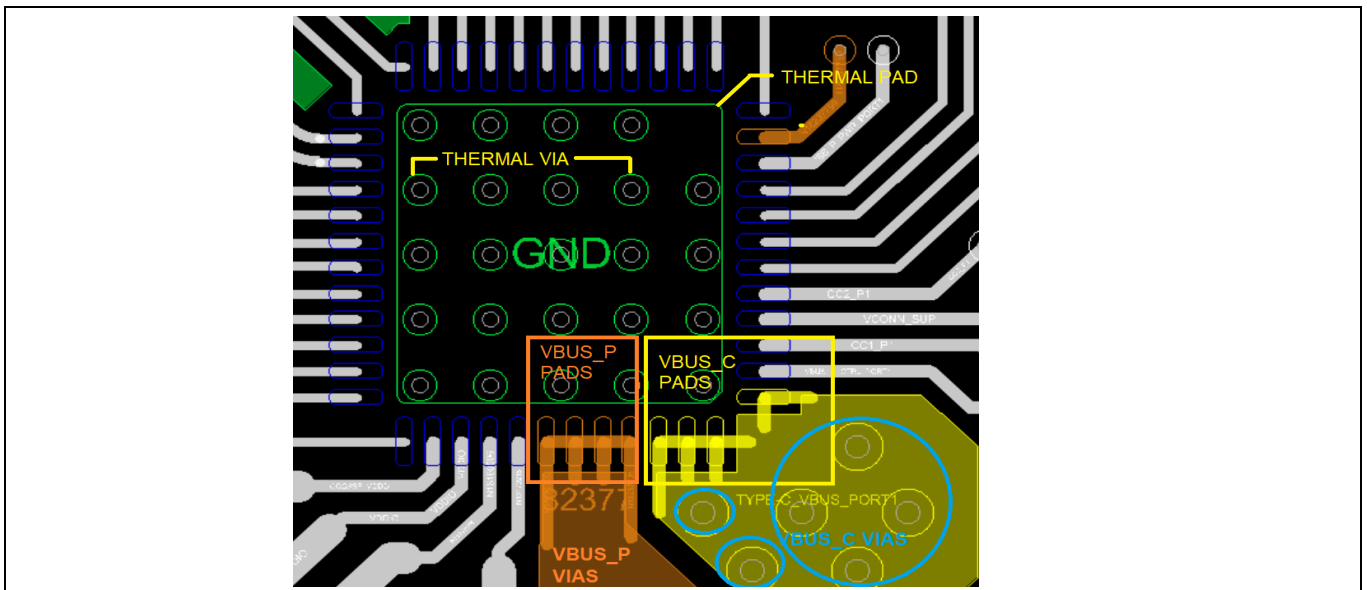

Figure 25 Via count for VBUS_P and VBUS_C (8/16 or 10/16 via sizes)

6.6 High-speed (DP/DM_SYS, DP/DM_BOT, DP/DM_TOP) USB connections fanout

Figure 26 shows differential fanout. The DP/DM lines from CCG6SF to connector should be differentially routed and length match $\pm 10\%$ tolerance. It should maintain $90\text{-}\Omega$ impedance.

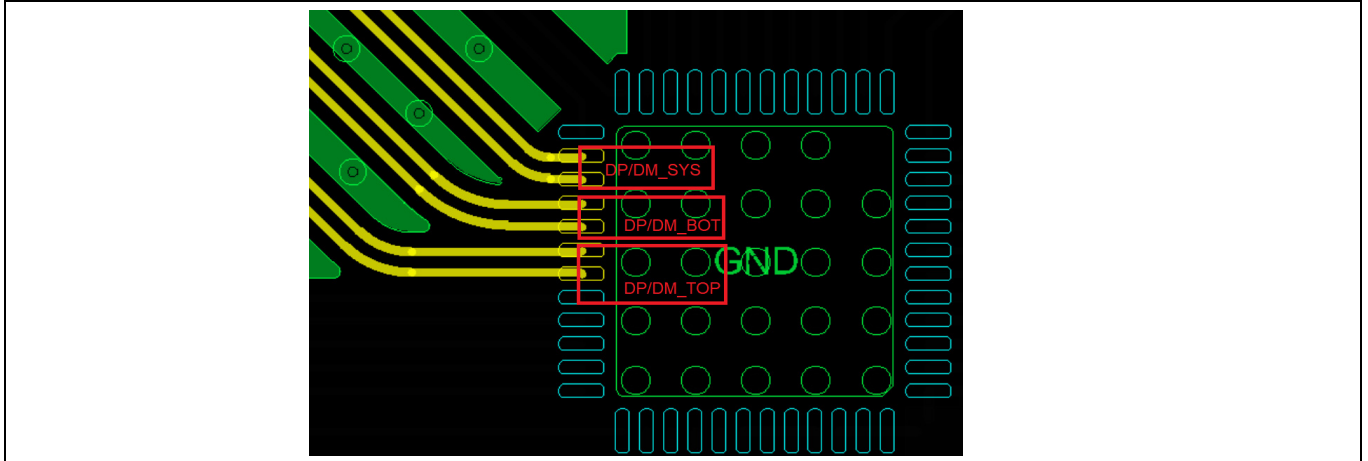

Figure 26 Differential fanout

6.7 CC connections

CC lines for CCG6DF/CCG6SF devices carry ~500-mA current. It is recommended to have 0.15 mm trace width for CC1, CC2, and V5V pads. The capacitors are placed on bottom layer and are routed to the Type-C connector. The CC1 and CC2 fanout is shown in **Figure 27** and **Figure 28**.

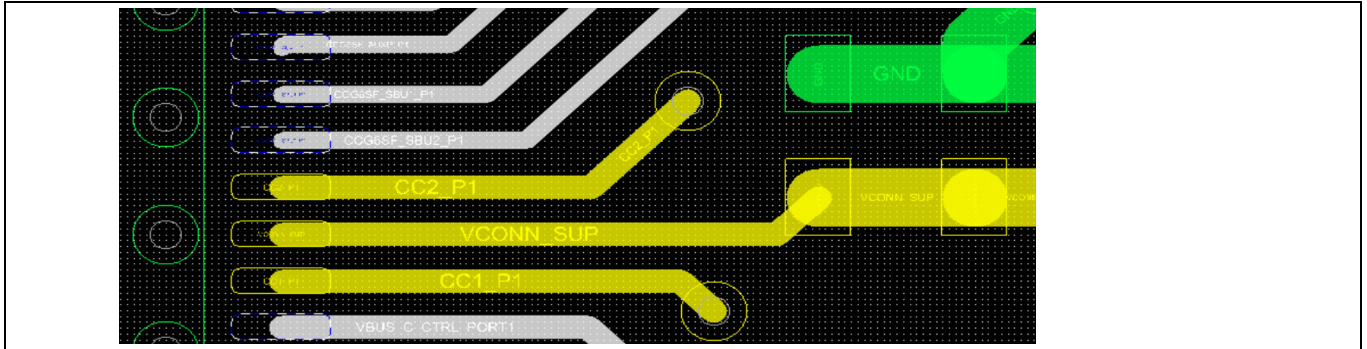

Figure 27 CC1 and CC2 fanout

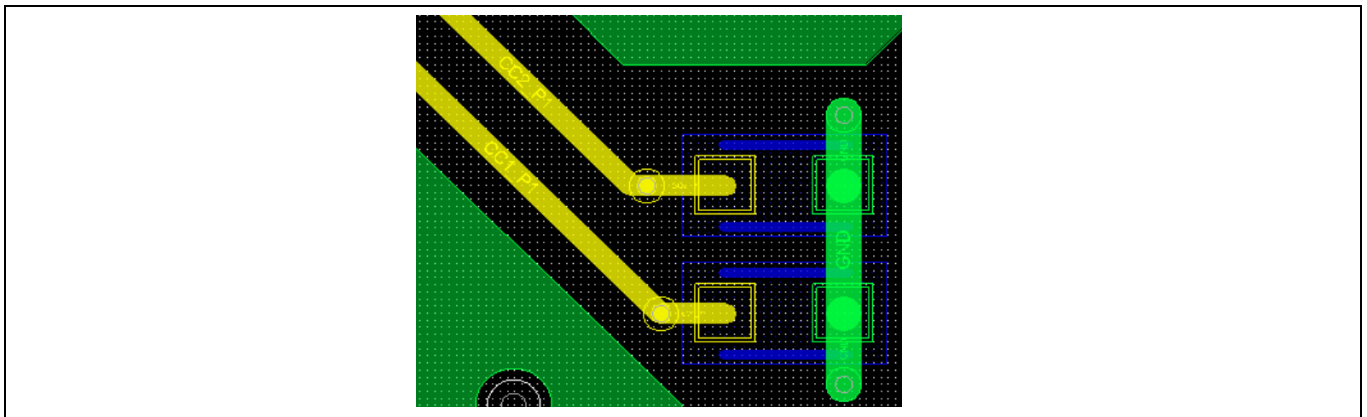

Figure 28 CC1 and CC2 caps

6.8 V_{DDIO} , V_{CCD} , V_{SYS} , and V_{DDD} connections

Figure 29 shows how the V_{DDIO} , V_{DDD} , V_{SYS} , and V_{CCD} signals get routed amongst the top and bottom layers.

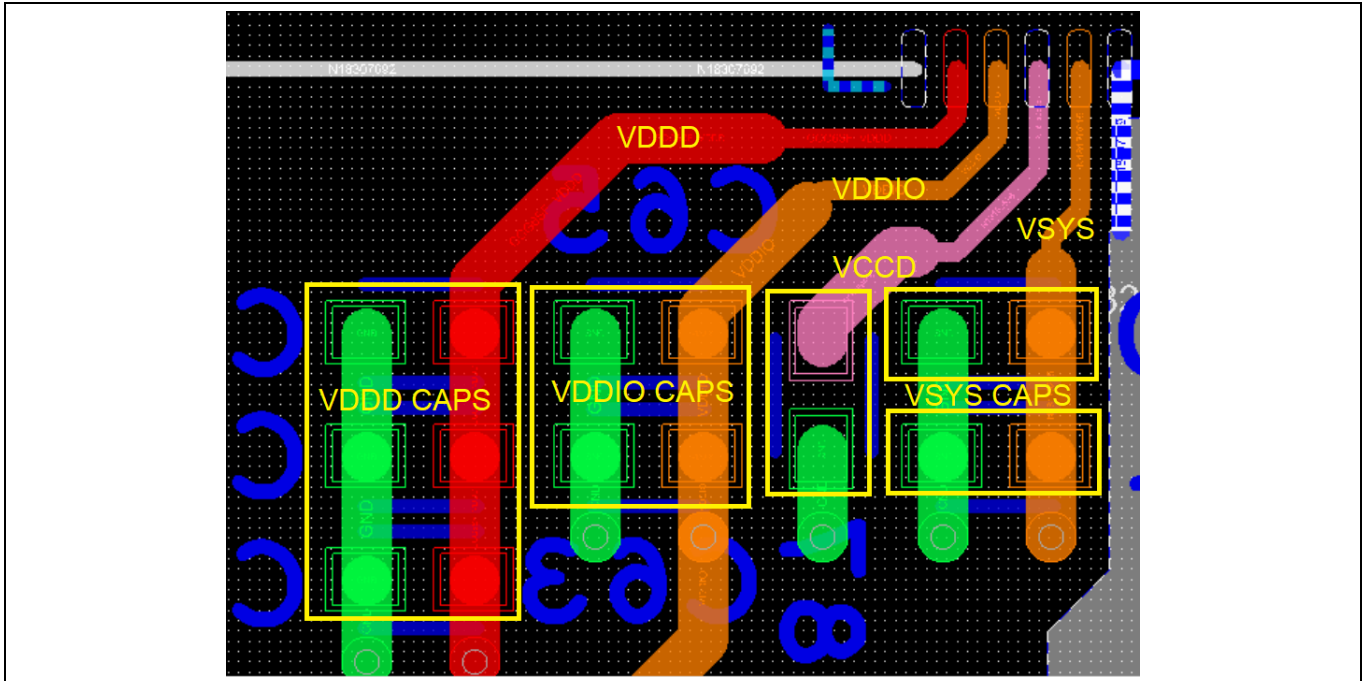

Figure 29 V_{DDIO} , V_{CCD} , V_{SYS} , and V_{DDD} connections

7 Electrical specifications

7.1 Absolute maximum ratings

Table 5 Absolute maximum ratings^[4]

Parameter	Description	Min	Typ	Max	Unit	Details/conditions
V _{SYS_MAX}	Supply relative to V _{SS}	–	–	6	V	–
V _{5V_MAX}	Max supply voltage relative to V _{SS}	–	–	6		
V _{BUS_C}	V _{BUS} voltage relative to V _{SS}	–0.3 ^[5]	–	24		
V _{DDIO_MAX}	Max supply voltage relative to V _{SS}	–	–	V _{DDD}		
V _{GPIO_ABS}	Inputs to GPIO, DP/DM mux (UART, SYS, DP/DM_top/bot pins), SBU mux (SBU1/2 pins)	–0.5	–	V _{DDIO} + 0.5		
I _{GPIO_ABS}	Maximum current per GPIO	–25	–	25	mA	–
I _{GPIO_INJECTION}	GPIO injection current, max for V _{IH} > V _{DDD} , and min for V _{IL} < V _{SS}	–0.5	–	0.5		Absolute max, current injected per pin
ESD_HBM	Electrostatic discharge human body model	2200	–	–	V	Applicable for all pins except SBU1_P0/1, SBU2_P0/1, CC1_0/1, CC2_0/1, VBUS_P_P0/1 & VBUS_C_P0/1 pins.
ESD_HBM_SBU	Electrostatic discharge human body model for SBU1, SBU2 pins	1100	–	–		Only applicable to SBU1_P0/1, SBU2_P0/1 pins
ESD_HBM_CC	Electrostatic discharge human body model for CC1 and CC2 pins for both ports	1100	–	–		Only applicable to CC1_P0/1, CC2_P0/1 pins
ESD_CDM	Electrostatic discharge charged device model	500	–	–		Charged device model ESD
ESD_HBM_VBUS	Electrostatic discharge human body model for VBUS_P_P0/1 & VBUS_C_P0/1 pins	500	–	–	V	Only applicable to VBUS_P_P0/1 and VBUS_C_P0/1 pins
LU	Pin current for latch-up	–100	–	100	mA	–

Notes

- Usage above the absolute maximum conditions listed in **Table 5** may cause permanent damage to the device. Exposure to absolute maximum conditions for extended periods of time may affect device reliability. The maximum storage temperature is 150°C in compliance with JEDEC standard JESD22-A103, high temperature storage life. When used below absolute maximum conditions but above normal operating conditions, the device may not operate to specification.
- In a system, if the negative spike exceeds the minimum voltage specified here, it is recommended to add schottky diode to clamp the negative spike.

Electrical specifications

Table 5 Absolute maximum ratings^[4]

Parameter	Description	Min	Typ	Max	Unit	Details/conditions
VCC_PIN_ABS	Max voltage on CC1 and CC2 pins	-	-	24	V	-
VSBU_PIN_ABS	Max voltage on SBU1 and SBU2 pins	-	-	24		-
VGPIO_OVT_ABS	OVT pins (16, 17) voltage	-0.5	-	6		-
T _A	Internal system ambient temperature	-40	-	55	°C	Ambient temp inside system enclosure
T _J	Junction temperature	-40	-	125		-

7.2 Device-level specifications

All specifications are valid for $-40^{\circ}\text{C} \leq T_A \leq 55^{\circ}\text{C}$ and $T_J \leq 125^{\circ}\text{C}$, except where noted. Specifications are valid for 3.0 to 5.5 V except where noted.

7.2.1 DC specifications

Table 6 DC specifications (Operating conditions)

Spec ID	Parameter	Description	Min	Typ	Max	Unit	Details/conditions	
SID.PWR#23	$V_{\text{SYS_UFP}}$	VSYS valid range	2.75	-	5.5	V	UFP applications	
SID.PWR#23_A	$V_{\text{SYS_UFP_DRP}}$	-	3	-	5.5		DFP/DRP applications	
PWR#22	VBUS_C	VBUS_C port 0/1 valid range	4	-	21.5		-	
SID.PWR#22A	VBUS_MAX	Max VBUS_C_P0/1 voltage relative to VSS	-	-	24		-40°C to +55°C T_A , absolute maximum A far-end short through cable resulting in a maximum of 30 V allowed with the following conditions: Max pulse-width of 2 at 27 V No more than 1000 times during the entire life-cycle	
SID.PWR#24	VBUS_P	VBUS_P port 0/1 valid range	4.9	-	5.5		This is not a power pin.	
SID.PWR#1	V_{DDD}	Regulated output voltage when V_{SYS} powered	$V_{\text{SYS}} - 0.05$	-	V_{SYS}		$-40^{\circ}\text{C} \leq T_A \leq +55^{\circ}\text{C}$	
SID.PWR#1_A	V_{DDD}	Regulated output voltage when V_{BUS} powered	3	-	3.65		$-40^{\circ}\text{C} \leq T_A \leq +55^{\circ}\text{C}$	
SID.PWR#26	V_{5V}	-	4.85	-	5.5		-	
SID.PWR#13	V_{DDIO}	Supply voltage for I/O	V_{DDD}	-	V_{DDD}		$-40^{\circ}\text{C} \leq T_A \leq +55^{\circ}\text{C}$, all V_{DDD}	
SID.PWR#24	V_{CCD}	Regulated output voltage (for core logic)	-	1.8	-		-	
SID.PWR#15	C_{EFC}	Regulator bypass capacitor for V_{CCD}	-	100	-		nF	X5R ceramic
SID.PWR#16	C_{EXC}	Power supply decoupling capacitor for V_{DDD}	-	1	-		μF	
Active mode, $V_{\text{SYS}} = 2.75 \text{ V to } 5.5 \text{ V}$. Typical values measured at $V_{\text{SYS}} = 3.3 \text{ V}$.								
SID.PWR#4	I_{DD12}	Supply current	-	10	-	mA	$T_A = 25^{\circ}\text{C}$, CC I/O IN transmit or receive, no I/O sourcing current, CPU at 24 MHz, PD port active	

Electrical specifications

Table 6 DC specifications (Operating conditions) (continued)

Spec ID	Parameter	Description	Min	Typ	Max	Unit	Details/conditions
Deep Sleep mode, $V_{SYS} = 2.75\text{ V to }3.6\text{ V}$							
SID34	I_{DD29}	$V_{SYS} = 2.75\text{ to }3.6\text{ V}$, I ² C, wakeup and WDT on.	–	150	–	μA	$V_{SYS} = 3.3\text{ V}$, $T_A = 25^\circ\text{C}$
SID_DS1	I_{DD_DS1}	$V_{SYS} = 3.3\text{ V}$, CC wakeup on, Type-C not connected.	–	200	–	μA	Power source = V_{SYS} , Type-C not attached, CC enabled for wakeup, R_P and R_D connected at 70-ms intervals by CPU. R_D connection should be enabled by both PD ports.
SID_DS3	I_{DD_DS2}	$V_{SYS} = 3.3\text{ V}$, CC wakeup on, DP/DM, SBU ON with Provider NGDO/CSA/UVOV On	–	500	–		One port attached, Chip in Deep Sleep Note: VBUS_C_CTRL_P0 and VBUS_C_CTRL_P1 should be OFF for the CCG6DF controller and VBUS_C_CTRL should be OFF for CCG6SF controller to be able to enter Deep Sleep mode.
XRES current							
SID307	I_{DD_XR}	Supply current while XRES asserted	–	130	–	μA	Power source = $V_{SYS} = 3.3\text{ V}$, Type-C not attached, $T_A = 25^\circ\text{C}$

7.2.2 CPU

Table 7 CPU specifications (Guaranteed by characterization)

Spec ID	Parameter	Description	Min	Typ	Max	Unit	Details/conditions
SID.CLK#4	F _{CPU}	CPU input frequency	-	-	48	MHz	-40°C ≤ T _A ≤ +55°C, all V _{DDD}
SID.PWR#21	T _{DEEPSLEEP}	Wakeup from Deep Sleep mode	-	35	-	μs	Guaranteed by characterization
SYS.XRES#5	T _{XRES}	External reset pulse width	5	-	-		
SYS.FES#1	T _{PWR_RDY}	Power-up to "Ready to accept I ² C/CC command"	-	5	25	ms	

7.2.3 GPIO

Table 8 GPIO DC specifications

Spec ID	Parameter	Description	Min	Typ	Max	Unit	Details/conditions
SID.GIO#37	V_{IH_CMOS}	Input voltage HIGH threshold	$0.7 \times V_{DDIO}$	-	-	V	CMOS input
SID.GIO#38	V_{IL_CMOS}	Input voltage LOW threshold	-	-	$0.3 \times V_{DDIO}$		
SID.GIO#39	$V_{IH_VDDIO2.7-}$	LVTTL input, $V_{DDIO} < 2.7\text{ V}$	$0.7 \times V_{DDIO}$	-	-		
SID.GIO#40	$V_{IL_VDDIO2.7-}$	LVTTL input, $V_{DDIO} < 2.7\text{ V}$	-	-	$0.3 \times V_{DDIO}$		
SID.GIO#41	$V_{IH_VDDIO2.7+}$	LVTTL input, $V_{DDIO} \geq 2.7\text{ V}$	2.0	-	-		
SID.GIO#42	$V_{IL_VDDIO2.7+}$	LVTTL input, $V_{DDIO} \geq 2.7\text{ V}$	-	-	0.8		
SID.GIO#33	V_{OH_3V}	Output voltage HIGH level	$V_{DDIO} - 0.6$	-	-	V	$I_{OH} = -4\text{ mA}$ at 3-V V_{DDIO}
SID.GIO#35C	V_{OL1_20mA}	Output low voltage	-	-	0.4		$I_{OL} = 20\text{ mA}$, $V_{DDIO} > 3.0\text{ V}$, applicable for overvoltage-tolerant pins only
SID.GIO#36	V_{OL_3V}	Output voltage LOW level	-	-	0.6	V	$I_{OL} = 10\text{ mA}$ at 3-V V_{DDIO}
SID.GIO#5	Rpu	Pull-up resistor when enabled	3.5	5.6	8.5	k Ω	+25°C T_A , All V_{DDIO}
SID.GIO#6	Rpd	Pull-down resistor when enabled	3.5	5.6	8.5		
SID.GIO#16	I_{IL}	Input leakage current (absolute value)	-	-	2	nA	+25°C T_A , 3-V V_{DDIO}
SID.GIO#17	C_{PIN}	Max pin capacitance	-	3	7	pF	-40°C $\leq T_A \leq$ +55°C, all V_{DD} , all I/Os
SID.GIO#43	V_{HYSTTL}	Input hysteresis, LVTTL, $V_{DDIO} > 2.7\text{ V}$	15	40	-	mV	$V_{DDIO} > 2.7\text{ V}$. Guaranteed by characterization.
SID.GIO#44	$V_{HYSCMOS}$	Input hysteresis CMOS	$0.05 \times V_{DDIO}$	-	-		$V_{DDIO} < 4.5\text{ V}$
SID.GIO#44A	$V_{HYSCMOS55}$	Input hysteresis CMOS	200	-	-		$V_{DDIO} > 4.5\text{ V}$
SID.GIO#41A	V_{IH_VCCHIB}	V_{IH} , 1.8 V input mode	1.26	-	-	V	-
SID.GIO#42A	V_{IL_VCCHIB}	V_{IL} , 1.8 V input mode	-	-	0.54		-
SID.GIO#43A	V_{HYS_VCCHIB}	Input hysteresis, 1.8 V input mode	90	-	-	mV	-

Table 9 GPIO AC specifications (guaranteed by characterization)

Spec ID	Parameter	Description	Min	Typ	Max	Unit	Details/conditions
SID70	T _{RISEF}	Rise time in Fast Strong mode	2	-	12	ns	3.3-V V _{DDIO} , C _{load} = 25 pF
SID71	T _{FALLF}	Fall time in Fast Strong mode	2	-	12		
SID.GIO#46	T _{RISES}	Rise time in Slow Strong mode	10	-	60		
SID.GIO#47	T _{FALLS}	Fall time in Slow Strong mode	10	-	60		
SID.GIO#48	F _{GPIO_OUT1}	GPIO F _{OUT} ; 3.3 V ≤ V _{DDIO} ≤ 5.5 V. Fast Strong mode.	-	-	16	MHz	90/10%, 25-pF load
SID.GIO#49	F _{GPIO_OUT2}	GPIO F _{OUT} ; 1.7 V ≤ V _{DDIO} ≤ 3.3 V. Fast Strong mode.	-	-	16	MHz	90/10%, 25-pF load
SID.GIO#50	F _{GPIO_OUT3}	GPIO F _{OUT} ; 3.3 V ≤ V _{DDIO} ≤ 5.5 V. Slow Strong mode.	-	-	7		
SID.GIO#51	F _{GPIO_OUT4}	GPIO F _{OUT} ; 1.7 V ≤ V _{DDIO} ≤ 3.3 V. Slow Strong mode.	-	-	3.5		
SID.GIO#52	F _{GPIO_IN}	GPIO input operating frequency; 1.7 V ≤ V _{DDIO} ≤ 5.5 V.	-	-	16		90/10% V _{IO}

7.2.4 XRES

Table 10 XRES DC specifications

Spec ID	Parameter	Description	Min	Typ	Max	Unit	Details/conditions
SID.XRES#1	V _{IH_XRES}	Input voltage HIGH threshold on XRES pin	0.7 × V _{DDIO}	-	-	V	CMOS input
SID.XRES#2	V _{IL_XRES}	Input voltage LOW threshold on XRES pin	-	-	0.3 × V _{DDIO}		
SID.XRES#3	C _{IN_XRES}	Input capacitance on XRES pin	-	-	7	pF	-
SID.XRES#4	V _{HYSXRES}	Input voltage hysteresis	-	0.05 × V _{DDIO}	-	mV	Guaranteed by characterization

7.3 Digital peripherals

The following specifications apply to the timer/counter/PWM peripherals in the Timer mode.

7.3.1 Pulse width modulation (PWM) for GPIO pins

Table 11 PWM AC specifications (guaranteed by characterization)

Spec ID	Parameter	Description	Min	Typ	Max	Unit	Details/conditions
SID.TCPWM.3	TCPWM _{FREQ}	Operating frequency	-	-	F _c	MHz	F _c max = 48 MHz
SID.TCPWM.4	T _{PWMENEXT}	Input trigger pulse width	2/F _c	-	-	ns	For all trigger events
SID.TCPWM.5	T _{PWMEXT}	Output trigger pulse width	2/F _c	-	-		Minimum possible width of overflow, underflow, and CC (counter equals compare value) outputs
SID.TCPWM.5A	T _{CRRES}	Resolution of counter	1/F _c	-	-		Minimum time between successive counts
SID.TCPWM.5B	PWM _{RES}	PWM resolution	1/F _c	-	-		Minimum pulse width of PWM output
SID.TCPWM.5C	Q _{RES}	Quadrature inputs resolution	1/F _c	-	-		Minimum pulse width between quadrature-phase inputs

7.3.2 I²C

Table 12 Fixed I²C AC specifications (guaranteed by characterization)

Spec ID	Parameter	Description	Min	Typ	Max	Unit	Details/conditions
SID153	F _{I2C1}	Bit rate	-	-	1	Mbps	-

7.3.3 UART

Table 13 Fixed UART AC specifications (guaranteed by characterization)

Spec ID	Parameter	Description	Min	Typ	Max	Unit	Details/conditions
SID162	F _{UART}	Bit rate	-	-	1	Mbps	-

7.3.4 SPI

Table 14 Fixed SPI AC specifications (guaranteed by characterization)

Spec ID	Parameter	Description	Min	Typ	Max	Unit	Details/conditions
SID166	F _{SPI}	SPI operating frequency (Master; 6X oversampling)	-	-	8	MHz	-

Table 15 Fixed SPI Master mode AC specifications (guaranteed by characterization)

Spec ID	Parameter	Description	Min	Typ	Max	Unit	Details/conditions
SID167	T _{DMO}	MOSI valid after SClk driving edge	-	-	15	ns	-
SID168	T _{DSI}	MISO valid before SClk capturing edge	20	-	-		Full clock, late MISO sampling
SID169	T _{HMO}	Previous MOSI data hold time	0	-	-		Referred to slave capturing edge

Table 16 Fixed SPI Slave mode AC specifications (guaranteed by characterization)

Spec ID	Parameter	Description	Min	Typ	Max	Unit	Details/conditions
SID170	T _{DMI}	MOSI valid before Sclck capturing edge	40	-	-	ns	-
SID171	T _{DSO}	MISO valid after Sclck driving edge	-	-	48 + (3 × T _{CPU})		T _{CPU} = 1/F _{CPU}
SID171A	T _{D_{SO}_EXT}	MISO valid after Sclck driving edge in Ext Clk mode	-	-	48		-
SID172	T _{H_{SO}}	Previous MISO data hold time	0	-	-		-
SID172A	T _{SSEL_{SCK}}	SSEL valid to first SCK Valid edge	100	-	-		-

7.3.5 Memory

Table 17 Flash AC specifications

Spec ID	Parameter	Description	Min	Typ	Max	Unit	Details/conditions
SID.MEM#4	T _{ROW_WRITE}	Row (Block) write time (erase and program)	-	-	20	ms	-40°C ≤ T _A ≤ +55°C, all V _{DDD}
SID.MEM#3	T _{ROW_ERASE}	Row erase time	-	-	13		
SID.MEM#8	T _{ROWPROGRAM}	Row program time after erase	-	-	7		
SID178	T _{BULKERASE}	Bulk erase time (64 KB)	-	-	35	s	Guaranteed by design
SID180	T _{DEVPROG}	Total device program time	-	-	25		
SID.MEM#6	FLASH_ENPB	Flash write endurance	100k	-	-	cycles	-
SID182	F _{RET1}	Flash retention, T _A ≤ 55°C, 100K P/E cycles	20	-	-	years	-
SID182A	F _{RET2}	Flash retention, T _A ≤ 85°C, 10K P/E cycles	10	-	-		-

7.4 System resources

7.4.1 Power-on-reset (POR) with brown out

Table 18 Imprecise power-on reset (IPOR)

Spec ID	Parameter	Description	Min	Typ	Max	Unit	Details/conditions
SID185	V _{RISEIPOR}	Power-on reset (POR) rising trip voltage	0.80	-	1.50	V	-
SID186	V _{FALLIPOR}	POR falling trip voltage	0.70	-	1.4		

Table 19 Precise POR

Spec ID	Parameter	Description	Min	Typ	Max	Unit	Details/conditions
SID190	V _{FALLPPOR}	Brown-out detect (BOD) trip voltage in active/sleep modes	1.48	-	1.62	V	-
SID192	V _{FALLDPSLP}	BOD trip voltage in Deep Sleep mode	1.1	-	1.5		

7.4.2 SWD interface

Table 20 SWD interface specifications

Spec ID	Parameter	Description	Min	Typ	Max	Unit	Details/conditions
SID.SWD#1	F_SWDCCLK1	$3.3\text{ V} \leq V_{\text{DDIO}} \leq 5.5\text{ V}$	-	-	14	MHz	SWDCCLK ≤ 1/3 CPU clock frequency
SID.SWD#2	F_SWDCCLK2	$1.8\text{ V} \leq V_{\text{DDIO}} \leq 3.3\text{ V}$	-	-	7		
SID.SWD#3	T_SWDI_SETUP	$T = 1/f\text{ SWDCCLK}$	$0.25 \times T$	-	-	ns	-
SID.SWD#4	T_SWDI_HOLD	$T = 1/f\text{ SWDCCLK}$	$0.25 \times T$	-	-		
SID.SWD#5	T_SWDO_VALID	$T = 1/f\text{ SWDCCLK}$	-	-	$0.50 \times T$		
SID.SWD#6	T_SWDO_HOLD	$T = 1/f\text{ SWDCCLK}$	1	-	-		

7.4.3 Internal main oscillator

Table 21 IMO AC specifications (guaranteed by design)

Spec ID	Parameter	Description	Min	Typ	Max	Unit	Details/conditions
SID.CLK#13	F _{IMOTOL}	Frequency variation at 48 MHz (trimmed)	-	-	±2	%	$2.7\text{ V} \leq V_{\text{DDD}} < 5.5\text{ V}$, $-25^\circ\text{C} \leq T_{\text{A}} \leq 55^\circ\text{C}$
SID226	T _{STARTIMO}	IMO start-up time	-	-	7	µs	-
SID.CLK#1	F _{IMO}	IMO frequency	-	48	-	MHz	$-40^\circ\text{C} \leq T_{\text{A}} \leq +55^\circ\text{C}$, all V _{DDD}

7.4.4 Internal low-speed oscillator

Table 22 ILO AC specifications

Spec ID	Parameter	Description	Min	Typ	Max	Unit	Details/conditions
SID234	T _{STARTILO1}	I _{LO} start-up time	–	–	2	ms	Guaranteed by characterization
SID238	T _{ILODUTY}	I _{LO} duty cycle	40	50	60	%	
SID.CLK#5	F _{ILO}	I _{LO} frequency	20	40	80	kHz	–

7.4.5 Consumer NGDO

Table 23 Consumer NGDO specifications

Spec ID	Parameter	Description	Min	Typ	Max	Unit	Details/conditions
SID.GD.1	GD_VGS	Gate to source overdrive during ON condition	4.5	–	10	V	NFET driver is ON.
SID.GD.2	GD_RPD	Resistance when pull-down enabled	–	–	2	kΩ	Applicable on VBUS_C_CTRL_P0/1 to turn OFF external NFET.
SID.GD.3	GD_VGS_OFF	Gate to Source overdrive during OFF condition	–	–	–VBUS_MAX	V	External NFET must be able to tolerate “VGS < –VBUS_MAX” in OFF state as Vgate = 0 V.
SID.GD.4	IOUT_VBUS_C_CTRL	Output current from VBUS_C_CTRL pin when consumer NGDO is enabled	3.44	4.3	5.16	μA	Consumer NGDO is enabled and voltage on VBUS_C_CTRL pin at 1.4 V–5.5 V (decimal setting of slew-ctrl register = 27)

7.4.6 PD

Table 24 PD DC specifications

Spec ID	Parameter	Description	Min	Typ	Max	Unit	Details/conditions
SID.DC.cc_shvt.1	vSwing	Transmitter output high voltage	1.05	-	1.2	V	-
SID.DC.cc_shvt.2	vSwing_low	Transmitter output low voltage	-	-	0.075		-
SID.DC.cc_shvt.3	zDriver	Transmitter output impedance	33	-	75	Ω	-
SID.DC.cc_shvt.4	zBmcRx	Receiver input impedance	10	-	-	MΩ	Guaranteed by design
SID.DC.cc_shvt.5	Idac_std	Source current for USB standard advertisement	64	-	96	μA	-
SID.DC.cc_shvt.6	Idac_1p5a	Source current for 1.5 A at 5 V advertisement	165.6	-	194.4		-
SID.DC.cc_shvt.7	Idac_3a	Source current for 3 A at 5 V advertisement	303.6	-	356.4		-
SID.DC.cc_shvt.8	Rd	Pull down termination resistance when acting as UFP	4.59	-	5.61	kΩ	-
SID.DC.cc_shvt.9	Rd_db	Pull down termination resistance when acting as UFP, with dead battery	4.08	-	6.12		-
SID.DC.cc_shvt.10	zOPEN	CC impedance to ground when disabled	108	-	-	-	-
SID.DC.cc_shvt.11	DFP_default_0p2	CC voltages on DFP side-standard USB	0.15	-	0.25	V	-
SID.DC.cc_shvt.12	DFP_1.5A_0p4	CC voltages on DFP side-1.5 A	0.35	-	0.45		-
SID.DC.cc_shvt.13	DFP_3A_0p8	CC voltages on DFP side-3 A	0.75	-	0.85		-
SID.DC.cc_shvt.14	DFP_3A_2p6	CC voltages on DFP side-3 A	2.45	-	2.75		-
SID.DC.cc_shvt.15	UFP_default_0p66	CC voltages on UFP side-standard USB	0.61	-	0.7		-
SID.DC.cc_shvt.16	UFP_1.5A_1p23	CC voltages on UFP side-1.5 A	1.16	-	1.31		-
SID.DC.cc_shvt.17	Vattach_ds	Deep sleep attach threshold	0.3	-	0.6	%	-
SID.DC.cc_shvt.18	Rattach_ds	Deep sleep pull-up resistor	10	-	50	kΩ	-

Table 24 PD DC specifications (continued)

Spec ID	Parameter	Description	Min	Typ	Max	Unit	Details/conditions
SID.DC.cc_shvt.19	VTX_step	TX drive voltage step size	80	–	120	mV	–
SID.DC.cc_shvt.30	FS_0p53	Voltage threshold for fast swap detect	0.49	–	0.58	V	–

7.4.7 Analog-to-digital converter

Table 25 ADC DC specifications

Spec ID	Parameter	Description	Min	Typ	Max	Unit	Details/conditions
SID.ADC.1	Resolution	ADC resolution	–	8	–	Bits	–
SID.ADC.2	INL	Integral non-linearity	–1.5	–	1.5	LSB	–
SID.ADC.3	DNL	Differential non-linearity	–2.5	–	2.5		–
SID.ADC.4	Gain Error	Gain error	–1.5	–	1.5		–
SID.ADC.5	VREF_ADC1	Reference voltage of ADC	V_{DDmin}	–	V_{DDmax}	V	Reference voltage generated from V_{DD}
SID.ADC.6	VREF_ADC2	Reference voltage of ADC	1.96	2.0	2.04		Reference voltage generated from deep sleep reference

7.4.8 V_{SYS} switch

Table 26 V_{SYS} switch specifications

Spec ID	Parameter	Description	Min	Typ	Max	Unit	Details/conditions
SID.DC.VDDDSW.1	Res_sw	Resistance from supply input to output supply V_{DD}	–	–	1.5	Ω	Measured with a load current of 5 mA to 10 mA on V_{DD} .

7.4.9 CSA

Table 27 CSA DC specifications

Spec ID	Parameter	Description	Min	Typ	Max	Unit	Details/conditions
DC.csa_scp.42	SCP_6A	Short circuit current detect @ 6 A	-	±10	-	%	-
DC.csa_scp.43	SCP_10A	Short circuit current detect @ 10 A	-	±10	-		-
OP.csa_scp.11	Rsense	External sense register	4.95	5	5.05	mΩ	
DC.csa_scp.44	locp_1A	OCP Trip threshold for 1A	-	130 ± 20%	-	%	1A PD contracts OCP set at 130% of contract value or user programmable
DC.csa_scp.45	locp_5A	OCP Trip threshold for 2 A, 3 A, 4 A and 5 A contracts	-	130 ± 10%	-		2A, 3A, 4A, and 5A PD contracts OCP set at 130% of contract value OR user programmable
DC.rcp_scp.7a	I_csainn_lk	CSP pin input leakage when RCP and CSA blocks are OFF	-	-	10	μA	For provider V _{BUS_P_P0/1} = 5 V.
DC.rcp_scp.6a	I_csainp_lk	CSN pin input leakage when RCP and CSA blocks are OFF	-	-	80		
DC.sys.1	I_CSP_RCP_ON_CSA_OFF	CSP pin current when RCP block is ON and SCP is OFF	-	-	20		
DC.sys.2	I_CSN_RCP_ON_CSA_OFF	CSN pin current when RCP block is ON and SCP is OFF	-	-	100		
DC.sys.3	I_CSP_CSA_ON	CSP pin current when RCP block is OFF and SCP is ON	-	-	30		
DC.sys.4	I_CSN_CSA_ON	CSN pin current when RCP block is OFF and SCP is ON	-	-	100		
DC.sys.5	I_CSP_RCP_ON_CSA_ON	CSP pin current when RCP block is ON and SCP is ON	-	-	50	μA	For provider V _{BUS} = 5 V. Guaranteed by design.
DC.sys.6	I_CSP_RCP_ON_CSA_ON	CSN pin current when RCP block is ON and SCP is ON	-	-	120		

Electrical specifications

7.4.10 V_{BUS} UV/OV

Table 28 V_{BUS} UV/OV specifications

Spec ID	Parameter	Description	Min	Typ	Max	Unit	Details/conditions
SID.UVOV.1	$V_{THUVOV1}$	Voltage threshold accuracy in active mode using bandgap reference	-	± 3	-	%	-
SID.UVOV.2	$V_{THUVOV2}$	Voltage threshold accuracy in deep sleep mode using deep sleep reference	-	± 5	-		-
SID.COMP_ACC	COMP_ACC	Comparator input offset at 4 sigma	-15	-	15	mV	-

7.4.11 Provider side RCP

Table 29 Provider side RCP DC specifications

Spec ID	Parameter	Description	Min	Typ	Max	Unit	Details/conditions
DC.RCP.44	Vcsa_rcp	Voltage across external Rsense between CSP/CSN for which RCP condition detected (CSN higher than CSP by Vcsa_rcp)	-	2	6	mV	-
DC.RCP.45	Vcomp_rcp	Voltage across V_{BUS} and CSN pins for which RCP condition is detected	20	-	130		-
DC.RCP.46	Vbus_max_det	Voltage on CSN pad during provider FET ON (source) for which RCP condition is triggered (this threshold is user programmable)	-	5.375	-	V	-

Table 30 Provider side RCP, SCP AC specifications

Spec ID	Parameter	Description	Min	Typ	Max	Unit	Details/conditions
AC.RCP_SYS.1	Toff_rcp	Provider NFET switching off after reverse current detect through provider FET (for 20-V hot plug-in)	-	1	-	μs	$V_{BUS} = 5\text{ V}/3\text{ A}$, provider path ON, 47- μF ceramic cap on V_{BUS_P} pin
AC.RCP_SYS.2	Ton	Time taken to detect RCP out-of-fault	-	55	80	μs	V_{BUS} falls below CSN and start NGDO enable

Table 31 V_{BUS} provider switch specifications

Spec ID	Parameter	Description	Min	Typ	Max	Unit	Details/conditions
DC.ngdo_fet_sys.1	RDS_{ON}	FET RDS_{ON} (96-BGA)	-	40	55	m Ω	3 A load current, short-duration pulse, -40°C to 55°C TA
DC.ngdo_fet_sys.1a	RDS_{ON}	FET RDS_{ON} (48-QFN)	-	45	55		
DC.NGDO_FET_SYS.2	I_{sw}	Continuous current	-	-	3.0	A	If one port is sourcing 3 A, the other port can source only up to 1.5 A. Measurement done in pulse mode.
AC.NGDO_FET_SYS.1	T_{on}	V_{BUS} low to high (10% to 90%)	-	5	-	ms	0.8 to 4.5-V transition, system-level (with 10- Ω load on V_{BUS_C})
AC.NGDO_FET_SYS.2	T_{off_fault}	V_{BUS} high to low (90% to 10%) - Under fault condition of SCP/RCP	-	1	-	μ s	
AC.NGDO_FET_SYS.3	T_{off}	V_{BUS} high to low (90% to 10%) - Under normal condition	-	7	-		4.5 to 0.8-V transition, system-level with external FET (with 10- Ω load on V_{BUS_C})
AC.NGDO_FET_SYS.4	OTSth_OFF	Overtemperature shutdown threshold OFF, Junction temperature	-	125	-	°C	-
AC.NGDO_FET_SYS.5	OTSth_OFF	Overtemperature shutdown threshold ON, Junction temperature	-	90	-	°C	

7.4.12 SBU switch

Table 32 SBU switch DC specifications

Spec ID	Parameter	Description	Min	Typ	Max	Unit	Details/conditions
DC.ccg6df.20sbu.1	Ron1	On resistance of AUXP/N to SBU1/2 switch @ 3.3-V input	-	4	7	Ω	-
DC.ccg6df.20sbu.2	Ron2	On resistance of AUXP/N to SBU1/2 switch @ 1-V input	-	3	5		-
DC.ccg6df.20sbu.4	Ileak1	Pin leakage current for SBU1, SBU2	-4.5	-	4.5	μA	-
DC.ccg6df.20sbu.5	Ileak2	Pin leakage current for SBU1_SYS, SBU2_SYS	-1	-	1	μA	-
DC.ccg6df.20sbu.16	OVP_threshold	Overvoltage protection detection threshold above V _{DDIO}	200	-	1200	mV	-
DC.ccg6df.20sbu.19	aux_ron_flat_fs	Switch On flat resistance of SBU1/2_SYS to SBU1/2 switch (from 0 to 3.3 V)	-	-	2.5	Ω	-
DC.ccg6df.20sbu.20	aux_ron_flat_hs	Switch On flat resistance of SBU1/2_SYS to SBU1/2 switch (from 0 to 1 V)	-	-	0.5		-

Table 33 SBU switch AC specifications

Spec ID	Parameter	Description	Min	Typ	Max	Unit	Details/conditions
AC.ccg6df.20sbu.1	Con	Switch on capacitance	-	-	120	pF	-
AC.ccg6df.20sbu.2	Coff	Switch off capacitance-connector side	-	-	80		Guaranteed by design
AC.ccg6df.20sbu.3	Off_isolation	Switch isolation at F = 1 MHz	-50	-	-	dB	
AC.ccg6df.20sbu.4	TON	SBU switch turn-on time	-	-	200	μs	-
AC.ccg6df.20sbu.5	TOFF	SBU switch turn-off time	-	-	400		-
AC.ccg6df.20sbu.3_aux	Off_isolation_AC_aux	Switch isolation at F = 1 MHz, from SBU_5V to SBU pins	-50	-	-	dB	Guaranteed by design
AC.ccg6df.20sbu.6_aux	Off_isolation_tran_dB_aux	Coupling on sbu1, 2 terminated to 50 Ω, switch-OFF, 1-MHz rail-to-rail toggling on SBU1_5V, SBU2_5V	-30	-	-		
AC.ccg6df.20sbu.7_aux	X_talk_AC_aux	Cross talk of Switch at F = 1 MHz SBU1/2 to SBU2/1 when is data transferred from SBU1/2_5V	-50	-	-		Guaranteed by design
AC.ccg6df.20sbu.8_aux	X_talk_tran_dB_aux	Coupling on SBU2(1) when data is transferred from SBU1(2)_5V to SBU1. (2) Rail-to-rail data on SBU1(2), static signal on SBU2(1)	-30	-	-		

7.4.13 DP/DM switch

Table 34 DP/DM switch DC specifications

Spec ID	Parameter	Description	Min	Typ	Max	Unit	Details/conditions
DC.ccg6df.dpdm.1	RON_HS	DP/DM on resistance (0 V to 0.5 V) - HS mode	-	-	8	Ω	-
DC.ccg6df.dpdm.2	RON_FS	DP/DM on resistance (0 V to 3.3 V) - FS mode	-	-	12		-
DC.ccg6df.dpdm.5	Con_FS	Switch on capacitance at 6 MHz - FS mode	-	-	50	pF	Guaranteed by design
DC.ccg6df.dpdm.6	Con_HS	Switch on capacitance at 240 MHz - HS mode	-	-	10		
DC.ccg6df.dpdm.9	ileak_pin	pin leakage at DP/DM connector side and host side	-	-	1	μA	-
DC.ccg6df.dpdm.10	RON_UART	DP/DM on resistance for UART lines (0 V to 3.3 V)	-	-	17	Ω	-
DC.ccg6df.dpdm.11	RON_FLAT_HS	DP/DM on Flat resistance in HS mode (0 V to 0.4 V)	-	-	0.5		-
DC.ccg6df.dpdm.12	RON_FLAT_FS	DP/DM on flat resistance in FS mode (0 V to 3.3 V)	-	-	4		-
DC.ccg6df.dpdm.13	RON_FLAT_UART	DP/DM UART On flat resistance (0 V to 3.3 V)	-	-	4		-

Table 35 DP/DM switch AC specifications

Spec ID	Parameter	Description	Min	Typ	Max	Unit	Details/conditions
AC.ccg6df.dpdm.1	BW_3dB_HS	3-db bandwidth	700	-	-	MHz	-
AC.ccg6df.dpdm.2	BW_3dB_FS	3-db bandwidth	100	-	-		
AC.ccg6df.dpdm.5	T _{ON}	DP/DM switch turn-on time	-	-	200	μs	-
AC.ccg6df.dpdm.6	T _{OFF}	DP/DM switch turn-off time	-	-	0.4		
AC.ccg6df.dpdm.7	T _{ON_VPUMP}	DP/DM charge pump startup time	-	-	200		
AC.ccg6df.dpdm.8	Off_isolation_HS	Switch-off isolation for HS	-20	-	-	dB	Guaranteed by design
AC.ccg6df.dpdm.9	Off_isolation_FS	Switch-off isolation for FS	-50	-	-		
AC.ccg6df.dpdm.10	X_talk	Cross talk of Switch From FS to HS at F = 12 MHz	-50	-	-		
AC.ccg6df.dpdm.11	uart_coupling	Peak-to-peak coupling of UART signal to DP lines. (UART signal 0 to 3.3 V)	-	-	20	mV	

7.4.14 VCONN switch

Table 36 VCONN switch DC specifications

Spec ID	Parameter	Description	Min	Typ	Max	Unit	Details/conditions
DC.ccg6df.20VCONN.1	R _{on}	Switch ON resistance at V5V = 5 V with 215-mA load current	-	0.7	1.3	Ω	-
DC.ccg6df.20VCONN.9	I _{OCP}	Overcurrent detection range for CC1/CC2	550	-	-	mA	-
DC.ccg6df.20VCONN.10	OVP_threshold	CC1, CC2 overvoltage protection detection threshold above V _{DD} or V5V, whichever is higher	200	-	1200	mV	-
DC.ccg6df.20VCONN.11	OVP_hysteresis	Overvoltage detection hysteresis	50	-	300		Guaranteed by design
DC.ccg6df.20VCONN.12	OCP_hysteresis	Overcurrent detection hysteresis	20	-	80	mA	Guaranteed by design
DC.ccg6.20VCONN.14	OVP_threshold_on	Overvoltage detection threshold above V5V of CC1/2, with CC1 or CC2 switch enabled. Same threshold triggers reverse current protection circuit.	200	-	700	mV	-

Table 37 VCONN switch AC specifications

Spec ID	Parameter	Description	Min	Typ	Max	Unit	Details/conditions
AC.ccg6df.20VCONN.1	T _{ON}	VCONN switch turn-on time	-	-	200	μs	-
AC.ccg6df.20VCONN.2	T _{OFF}	VCONN switch turn-off time	-	-	3		Guaranteed by design

7.4.15 V_{BUS}

Table 38 V_{BUS} discharge specifications

Spec ID	Parameter	Description	Min	Typ	Max	Unit	Details/conditions
SID.VBUS.DISC.1	Ron1	20-V NMOS ON resistance (with dischg_ds<0> = 1; dischg_ds<4:1> = 0)	1500	–	3000	Ω	–
SID.VBUS.DISC.2	Ron2	20-V NMOS ON resistance (with dischg_ds<1:0> = 1; dischg_ds<4:2> = 0)	750	–	1500		–
SID.VBUS.DISC.3	Ron3	20-V NMOS ON resistance (with dischg_ds<2:0> = 1; dischg_ds<4:3> = 0)	500	–	1000		–
SID.VBUS.DISC.4	Ron4	20-V NMOS ON resistance (with dischg_ds<3:0> = 1; dischg_ds<4> = 0)	375	–	750		–
SID.VBUS.DISC.5	Ron5	20-V NMOS ON resistance (with dischg_ds<4:0> = 1)	300	–	600		–

8 Ordering information

Table 39 lists the EZ-PD™ CCG6DF, EZ-PD™ CCG6SF part numbers and features.

Table 39 EZ-PD™ CCG6SF and CCG6DF ordering information

Product	Part number	Application	Integrated VBUS switch	Type-C ports	Dead battery termination	Termination resistor	Role	Package
CCG6SF	CYPD6127-48LQXI/T	Notebooks	Yes	1	Yes	Rp ^[6] , Rd ^[7]	DRP	48-pin QFN
	CYPD6128-48LQXI ^[8] /T							
CCG6DF	CYPD6227-96BZXI/T			2				96-ball BGA
	CYPD6228-96BZXI ^[8] /T							

8.1 Ordering code definitions

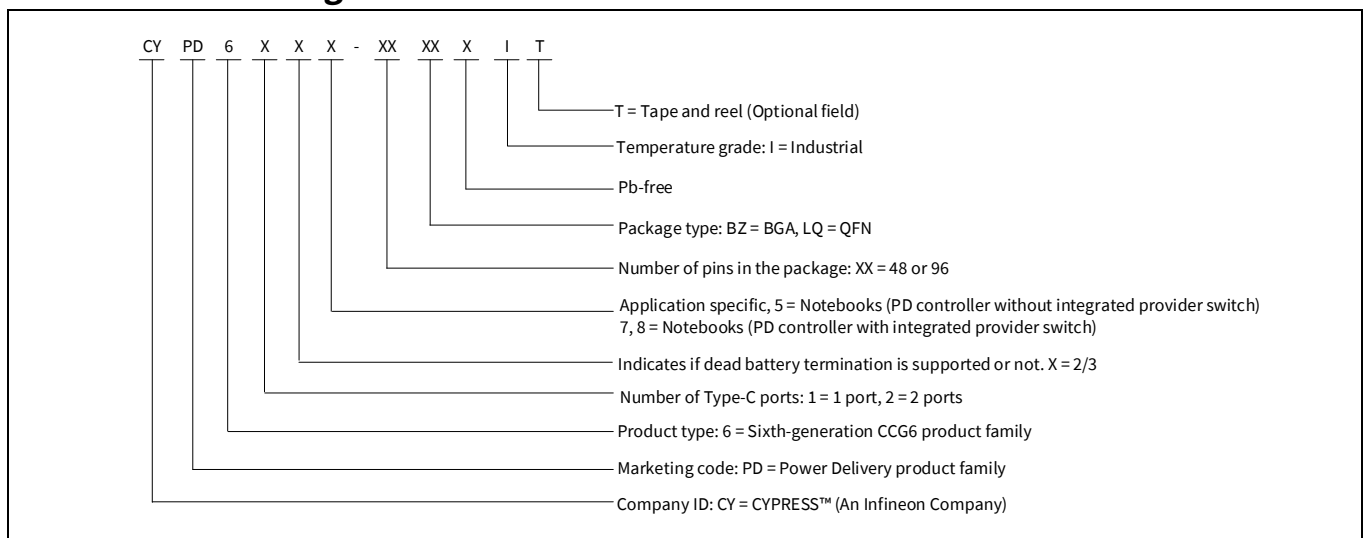

Notes

6. Termination resistor denoting a source.
7. Termination resistor denoting an accessory or sink.
8. Optimized ROM code.

9 Packaging

Table 40 Package characteristics

Parameter	Description	Conditions	Min	Typ	Max	Unit
T _A	Operating ambient temperature	Industrial	-40	25	55	°C
T _J	Operating junction temperature				125	
T _{JA}	Package θ_{JA} (96-ball BGA)	-	-	-	56.9	°C/W
T _{JC}	Package θ_{JC} (96-ball BGA)				36.9	
T _{JA}	Package θ_{JA} (48-pin QFN)	-	-	-	40.2	
T _{JC}	Package θ_{JC} (48-pin QFN)				40.1	

Table 41 Solder reflow peak temperature

Package	Maximum peak temperature	Maximum time within 5°C of peak temperature
96-ball BGA	260°C	30 seconds
48-pin QFN		

Table 42 Package moisture sensitivity level (MSL), IPC/JEDEC J-STD-2

Package	MSL
96-ball BGA	MSL 3
48-pin QFN	

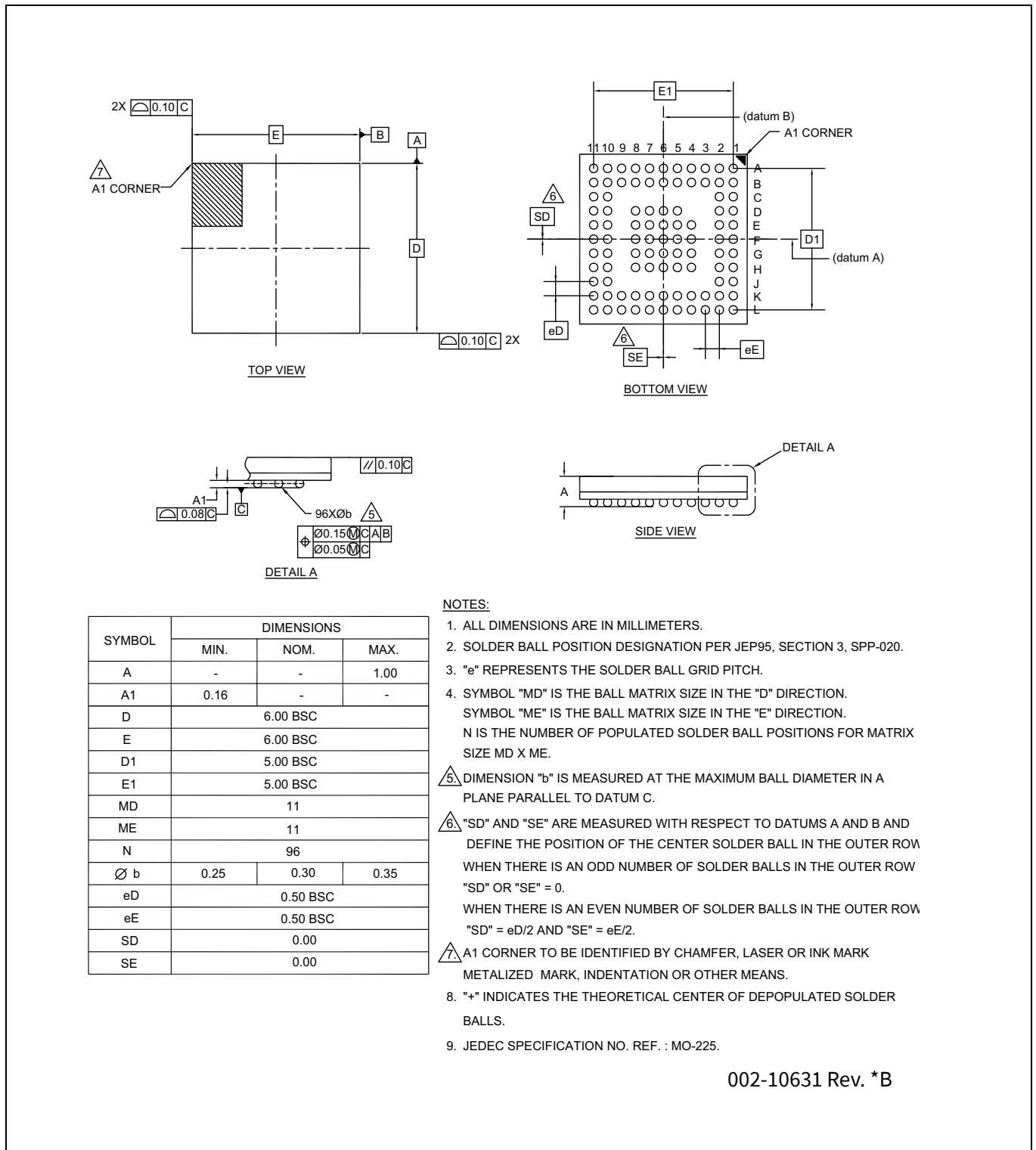

002-10631 Rev. *B

Figure 30 96-ball VFBGA (6.0 x 6.0 x 1.0 mm) R2A096/R3A096/BZ96A/VDM096 package outline (PG-VFBGA-96-800), 002-10631

Packaging

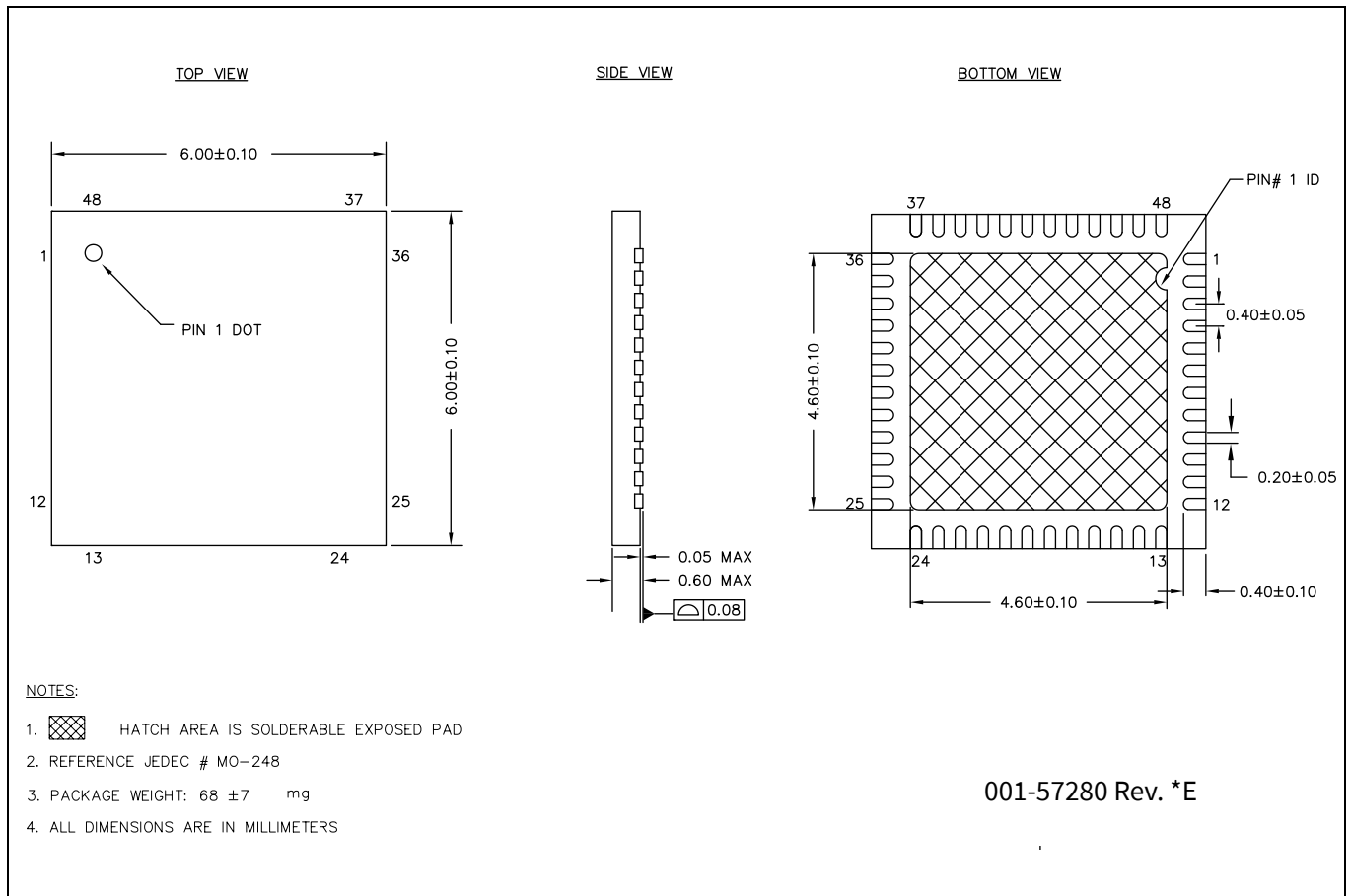

Figure 31 48-lead QFN ((6 × 6 × 0.6 mm) LR48A/LQ48A 4.6 × 4.6 E-Pad (Sawn)) package outline (PG-VQFN-48-800), 001-57280

10 Acronyms

Table 43 Acronyms used in this document

Acronym	Description
ADC	analog-to-digital converter
API	application programming interface
Arm®	advanced RISC machine, a CPU architecture
CC	configuration channel
CSN	current sense negative
BCC	battery charger controller
BOD	Brown out Detect
CC	configuration channel
CPU	central processing unit
CRC	cyclic redundancy check, an error-checking protocol
CS	current sense
CSA	current sense amplifier
CSN	current sense negative
CSP	current sense positive
DFP	downstream facing port
DM	data minus
DP	data plus signal
DP	DisplayPort, digital display interface developed by Video Electronics Standards Association
DIO	digital input/output, GPIO with only digital capabilities, no analog. See GPIO.
DRP	dual role power
EC	embedded controller
EEPROM	electrically erasable programmable read-only memory
EMCA	a USB cable that includes an IC that reports cable characteristics (For example, current rating) to the Type-C ports
EMI	electromagnetic interference
ESD	electrostatic discharge
FPB	flash patch and breakpoint
FRS	fast role swap
FS	full-speed
GPIO	general-purpose input/output
HDI	high density interconnect
HSCSA	high-side current sense amplifier
IC	integrated circuit
IDE	integrated development environment
I ² C, or IIC	Inter-Integrated Circuit, a communications protocol
ILO	internal low-speed oscillator, see also IMO

Table 43 Acronyms used in this document (continued)

Acronym	Description
IMO	internal main oscillator, see also ILO
I/O	input/output, see also GPIO
IPOR	imprecise POR
IRQ	interrupt request
ISR	interrupt service request
LVD	low-voltage detect
LVTTL	low-voltage transistor-transistor logic
MCU	microcontroller unit
MDI	medium density
NC	no connect
NGDO	N-FET gate driver output
NMI	nonmaskable interrupt
NVIC	nested vectored interrupt controller
opamp	operational amplifier
OCP	overcurrent protection
OVP	overvoltage protection
PCB	printed circuit board
PD	power delivery
PGA	programmable gain amplifier
PHY	physical layer
POR	power-on reset
PRES	precise power-on reset
PSoC™	Programmable System-on-Chip
PWM	pulse-width modulator
RAM	random-access memory
RCP	reverse current protection
RISC	reduced-instruction-set computing
RMS	root-mean-square
RTC	real-time clock
RX	receive
SAR	successive approximation register
SCB	serial communication block
SCL	I ² C serial clock
SDA	I ² C serial data
S/H	sample and hold
SMT	surface-mount technology
SPI	Serial Peripheral Interface, a communications protocol
SRAM	static random access memory
SWD	serial wire debug, a test protocol
TBT	Thunderbolt, hardware interface standard for peripherals developed by Intel

Table 43 Acronyms used in this document *(continued)*

Acronym	Description
TCPWM	timer/counter pulse-width modulation
TRNG	true random number generator
TX	transmit
Type-C	a new standard with a slimmer USB connector and a reversible cable, capable of sourcing up to 100 W of power
UART	universal asynchronous transmitter receiver, a communications protocol
UFP	upstream facing port
USB	Universal Serial Bus
USBIO	USB input/output, CCG6D/CCG6DF pins used to connect to a USB port
USBTCAS	USB Type-C authentication specification
UVOV	undervoltage/overvoltage
WDT	watchdog timer
XRES	external reset I/O pin

11 Document conventions

11.1 Units of measure

Table 44 Units of measure

Symbol	Unit of measure
°C	degrees Celsius
Hz	hertz
KB	1024 bytes
kHz	kilohertz
kΩ	kilo ohm
Mbps	megabits per second
MHz	megahertz
MΩ	mega-ohm
Msp/s	megasamples per second
μA	microampere
μF	microfarad
μs	microsecond
μV	microvolt
μW	microwatt
mA	milliampere
mΩ	milliohm
ms	millisecond
mV	millivolt
nA	nanoampere
ns	nanosecond
W	ohm
pF	picofarad
ppm	parts per million
ps	picosecond
s	second
sps	samples per second
V	volt

11.2 References and links to applications collateral

11.2.1 Knowledge base articles

- [Key Differences Among EZ-PD™ CCG1, CCG2, CCG3 and CCG5 - KBA210740](#)
- [Programming EZ-PD™ CCG2, EZ-PD™ CCG3 and EZ-PD™ CCG5 Using PSoC® Programmer and MiniProg3 - KBA96477](#)
- [CCGX Frequently Asked Questions \(FAQs\) - KBA97244](#)
- [Cypress EZ-PD™ CCGx Hardware - KBA204102](#)
- [Difference between USB Type-C and USB-PD - KBA204033](#)
- [CCGX Programming Methods - KBA97271](#)
- [Getting started with Cypress USB Type-C Products - KBA04071](#)
- [Type-C to DisplayPort Cable Electrical Requirements](#)
- [Dead Battery Charging Implementation in USB Type-C Solutions - KBA97273](#)
- [Termination Resistors Required for the USB Type-C Connector – KBA97180](#)
- [VBUS Bypass Capacitor Recommendation for Type-C Cable and Type-C to Legacy Cable/Adapter Assemblies – KBA97270](#)
- [Need for Regulator and Auxiliary Switch in Type-C to DisplayPort \(DP\) Cable Solution - KBA97274](#)
- [Need for a USB Billboard Device in Type-C Solutions – KBA97146](#)
- [Cypress USB Type-C Controller Supported Solutions – KBA97179](#)
- [Termination Resistors for Type-C to Legacy Ports – KBA97272](#)
- [Handling Instructions for CY4502 CCG2 Development Kit – KBA97916](#)
- [Thunderbolt™ Cable Application Using CCG3 Devices - KBA210976](#)
- [Power Adapter Application Using CCG3 Devices - KBA210975](#)
- [Methods to Upgrade Firmware on CCG3 Devices - KBA210974](#)
- [Device Flash Memory Size and Advantages - KBA210973](#)
- [Applications of EZ-PD™ CCG5 - KBA210739](#)

11.2.2 Application notes

- [AN95615 - Designing USB 3.1 Type-C Cables Using EZ-PD™ CCG2](#)
- [AN95599 - Hardware Design Guidelines for EZ-PD™ CCG2](#)
- [AN210403 - Hardware Design Guidelines for Dual Role Port Applications Using EZ-PD™ USB Type-C Controllers](#)
- [AN210771 - Getting Started with EZ-PD™ CCG4](#)

11.2.3 Reference designs

- [EZ-PD™ CCG2 Electronically Marked Cable Assembly \(EMCA\) Paddle Card Reference Design](#)
- [EZ-PD™ CCG2 USB Type-C to DisplayPort Cable Solution](#)
- [EZ-PD™ CCG2 USB Type-C to HDMI Adapter Solution](#)
- [EZ-USB GX3 USB Type-C to Gigabit Ethernet Dongle](#)
- [EZ-PD™ CCG2 USB Type-C Monitor/Dock Solution](#)
- [CCG2 20W Power Adapter Reference Design](#)
- [CCG2 18W Power Adapter Reference Design](#)

- [EZ-USB GX3 USB Type-A to Gigabit Ethernet Reference Design Kit](#)

11.2.4 Kits

- [CY4502 EZ-PD™ CCG2 Development Kit](#)
- [CY4531 EZ-PD™ CCG3 Evaluation Kit](#)
- [CY4541 EZ-PD™ CCG4 Evaluation Kit](#)

11.2.5 Datasheets

- [CYPD1120 Datasheet: USB Power Delivery Alternate Mode Controller on Type-C](#)
- [CCG2: USB Type-C Port Controller Datasheet](#)
- [CCG3: USB Type-C Controller Datasheet](#)
- [CCG5C: USB Type-C Controller Datasheet](#)

Revision history

Document revision	Date	Description of changes
**	2022-05-27	Initial release.
*A	2019-08-09	<p>Updated Document Tile to read as “EZ-PD™ CCG6DF, CCG6SF, USB Type-C Controller”.</p> <p>Updated General description: Updated description.</p> <p>Updated Features: Updated description.</p> <p>Updated Logic block diagram. Updated CCG6DF/CCG6SF functional diagram.</p> <p>Updated Pinouts: Updated table “Pinout for CYPD6227-96BZXI”. Added table “Pinout for CYPD6127-96BZXI”.</p> <p>Updated figure “96-Ball BGA Pin Map (Top View) for CYPD6227-96BZXI”. Added figure “96-Ball BGA Pin Map (Top View) for CYPD6127-96BZXI”.</p> <p>Updated Application diagrams: Updated description. Removed figure “CCG6D in a Dual Port Notebook Application”.</p> <p>Updated Ordering information: Updated Table 39 (Updated part numbers). Updated Packaging: Updated Table 40. Updated Table 41. Updated Table 42. Removed spec 001-80659 Rev. *A.</p>
*B	2019-09-13	<p>Changed document status from Advance to Preliminary.</p> <p>Updated Features: Updated description.</p> <p>Updated Logic block diagram. Updated CCG6DF/CCG6SF functional diagram. Added Functional overview. Added Power.</p> <p>Updated Pinouts: Updated table “Pinout for CYPD6227-96BZXI”. Updated table “Pinout for CYPD6127-96BZXI”.</p> <p>Updated figure “96-Ball BGA Pin Map (Top View) for CYPD6227-96BZXI”. Updated figure “96-Ball BGA Pin Map (Top View) for CYPD6127-96BZXI”.</p> <p>Updated Application diagrams: Added details.</p> <p>Updated Electrical specifications: Added details.</p> <p>Updated Ordering information: Updated Table 39.</p>

Revision history

Document revision	Date	Description of changes
*B (cont.)	2019-09-13	<p>Updated Packaging: Updated Table 42. No change in revisions. Updated References and links to applications collateral: Added details. Updated hyperlinks.</p>
*C	2019-09-26	<p>Updated Pinouts: Added table “Pinout for CYPD6127-48LQXI”. Added figure “48-pin QFN Pin Map for CYPD6127-48LQXI”. Updated Electrical specifications: Updated System resources: Updated Provider side RCP: Updated Table 31. Updated Ordering information: Updated Table 39. Updated Packaging: Added spec 001-57280 Rev. *E.</p>
*D	2019-11-18	<p>Updated General description: Updated description. Updated Features: Updated description. Updated Power: Added Figure 3. Updated Pinouts: Updated table “Pinout for CYPD6127-48LQXI”. Updated figure “48-pin QFN Pin Map for CYPD6127-48LQXI”. Updated Application diagrams: Updated Figure 6. Updated figure “CCG6SF 96-ball BGA Single Port Thunderbolt Notebook Application Diagram”. Added Figure 8. Updated Packaging: Updated Table 40. Updated Table 41. Updated Table 42. Updated Packaging: spec 002-10631 – Changed revision from *A to *B.</p>

Revision history

Document revision	Date	Description of changes
*E	2020-01-14	<p>Updated Logic block diagram. Updated Functional overview: Updated MCU subsystem: Updated SBU pass-through switch and USB HS mux: Updated Figure 1. Updated Pinouts: Updated table “Pinout for CYPD6227-96BZXI”. Updated table “Pinout for CYPD6127-96BZXI”. Updated figure “96-Ball BGA Pin Map (Top View) for CYPD6227-96BZXI”. Updated figure “96-Ball BGA Pin Map (Top View) for CYPD6127-96BZXI”. Updated Application diagrams: Updated Figure 6. Updated figure “CCG6SF 96-ball BGA Single Port Thunderbolt Notebook Application Diagram” Updated Electrical specifications: Updated Device-level specifications: Updated DC specifications: Updated Table 6. Updated System resources: Updated Provider side RCP: Updated Table 29. Updated Table 31. Updated CCG6DF, CCG6SF Layout Design Guidelines: Updated description. Added Usage of via size of 8-mil drill/16-mil diameter and 10-mil drill/16-mil diameter.</p>
*F	2020-03-13	<p>Updated General description: Updated description. Updated Features: Updated description. Updated Functional overview: Updated System resources: Updated Watchdog timer (WDT): Updated description. Updated Pinouts: Removed table “Pinout for CYPD6127-96BZXI”. Removed figure “96-Ball BGA Pin Map (Top View) for CYPD6127-96BZXI”. Updated Application diagrams: Removed figure “CCG6SF 96-ball BGA Single Port Thunderbolt Notebook Application Diagram”. Updated Packaging: Updated Table 40. Updated Acronyms.</p>

Revision history

Document revision	Date	Description of changes
*G	2020-05-28	<p>Changed document status from Preliminary to Final.</p> <p>Updated CCG6DF layout design guidelines for BGA package: Removed “CC Connections”.</p> <p>Added CCG6SF layout design guidelines for 48-QFN package.</p> <p>Updated Electrical specifications: Updated Absolute maximum ratings: Updated Table 5.</p> <p>Updated System resources: Added Consumer NGDO.</p> <p>Updated VCONN switch: Updated Table 36.</p> <p>Updated Ordering information: Updated Table 39.</p> <p>Completing Sunset Review.</p>
*H	2020-07-23	<p>Updated Electrical specifications: Updated Device-level specifications: Updated DC specifications: Updated Table 6.</p> <p>Updated GPIO: Updated Table 8.</p> <p>Updated System resources: Updated Consumer NGDO: Updated Table 23.</p>
*I	2021-04-14	<p>Updated Pinouts: Updated Table 2 (Updated caption only). Updated Table 3 (Updated caption only). Updated Figure 4 (Updated caption only). Updated Figure 5 (Updated caption only).</p> <p>Updated Application diagrams: Updated Figure 6. Updated Figure 8.</p> <p>Updated Ordering information: Updated Table 39 (Updated part numbers). Updated Ordering code definitions.</p>
*J	2022-07-14	<p>Updated Ordering information: Updated Table 39 (Updated part numbers). Updated Ordering code definitions. Migrated to Infineon template.</p>

Revision history

Document revision	Date	Description of changes
*K	2023-08-30	Updated Application diagrams : Updated Figure 6 . Updated Figure 7 . Updated Electrical specifications : Updated Device-level specifications : Updated DC specifications : Updated Table 6 . Updated to new template. Completing Sunset Review.

Trademarks

All referenced product or service names and trademarks are the property of their respective owners.

Edition 2023-08-30
Published by
Infineon Technologies AG
81726 Munich, Germany

© 2023 Infineon Technologies AG.
All Rights Reserved.

Do you have a question about this document?
Go to www.infineon.com/support

Document reference
002-27161 Rev. *K

IMPORTANT NOTICE

The information given in this document shall in no event be regarded as a guarantee of conditions or characteristics ("Beschaffenhheitsgarantie").

With respect to any examples, hints or any typical values stated herein and/or any information regarding the application of the product, Infineon Technologies hereby disclaims any and all warranties and liabilities of any kind, including without limitation warranties of non-infringement of intellectual property rights of any third party.

In addition, any information given in this document is subject to customer's compliance with its obligations stated in this document and any applicable legal requirements, norms and standards concerning customer's products and any use of the product of Infineon Technologies in customer's applications.

The data contained in this document is exclusively intended for technically trained staff. It is the responsibility of customer's technical departments to evaluate the suitability of the product for the intended application and the completeness of the product information given in this document with respect to such application.

For further information on the product, technology, delivery terms and conditions and prices please contact your nearest Infineon Technologies office (www.infineon.com).

WARNINGS

Due to technical requirements products may contain dangerous substances. For information on the types in question please contact your nearest Infineon Technologies office.

Except as otherwise explicitly approved by Infineon Technologies in a written document signed by authorized representatives of Infineon Technologies, Infineon Technologies' products may not be used in any applications where a failure of the product or any consequences of the use thereof can reasonably be expected to result in personal injury.

Looking for pricing, stock, or lifecycle information?

Click below to explore more details on WIN SOURCE:

- ⊖ [View CYPD6127-48LQXIT on WIN SOURCE](#)
- ⊖ [Infineon Technologies Information](#)

Optimize Your Supply Chain with WIN SOURCE Solutions

- ✓ Global Sourcing Solution
- ✓ Obsolete Management
- ✓ Cost Control Management
- ✓ Shortage Management
- ✓ Alternative Solution
- ✓ Excess Inventory Management