



THE DATASHEET OF
1582M25





FAN1582

3A Adjustable / Fixed Ultra Low Dropout Linear Regulator

Features

- Ultra low dropout voltage, 0.4V typical at 3A
- Remote sense operation
- Fast transient response
- Load regulation: 0.05% typical
- 0.5% initial accuracy
- On-chip thermal limiting
- 5-pin TO-263 package

Applications

- Support of GTL+ bus supply
- Low voltage logic supply
- Embedded processor supplies
- Split plane regulator
- 2.5V, and 1.8V logic families
- DDR termination supply

Description

The FAN1582, FAN1582-1.5, and FAN1582-2.5 are ultra low dropout regulators with 3A output current capability. These devices are optimized for low-voltage applications, including V_{TT} bus termination, where transient response and minimum input voltage are critical. The FAN1582 is ideal for low-voltage microprocessor applications requiring a regulated output from 1.3V to 5.7V with a power input supply of 1.75V to 6.5V.

The FAN1582-1.5 offers fixed 1.5V with 3A current capabilities for GTL+ bus V_{TT} termination.

The FAN1582-2.5 offers fixed 2.5V with 3A current capability for logic IC operation and processors while minimizing the overall power dissipation.

Current limit ensures controlled short-circuit current. On-chip thermal limiting provides protection against combination of overload and ambient temperature that would create excessive junction temperatures.

The FAN1582 is available in a 5-pin TO-263 power package.

Ordering Information

Part Number	Package	Pb-Free	Operating Temperature Range	Packing Method
FAN1582MX	5-Pin TO-263	Yes	-65 to 150°C	Tape and Reel
FAN1582M15X	5-Pin TO-263	Yes	-65 to 150°C	Tape and Reel
FAN1582M25X	5-Pin TO-263	Yes	-65 to 150°C	Tape and Reel

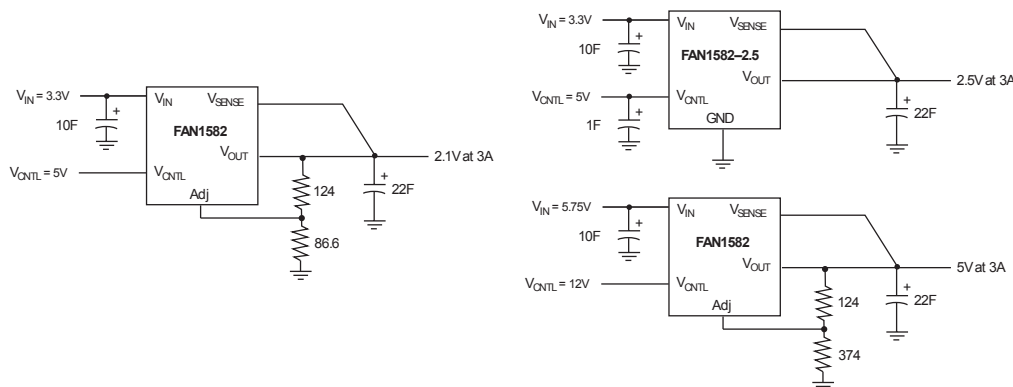

Figure 1. Typical Application

Pentium® is a registered trademark of Intel® corporation. PowerPC™ is a trademark of IBM Corporation.

Block Diagram

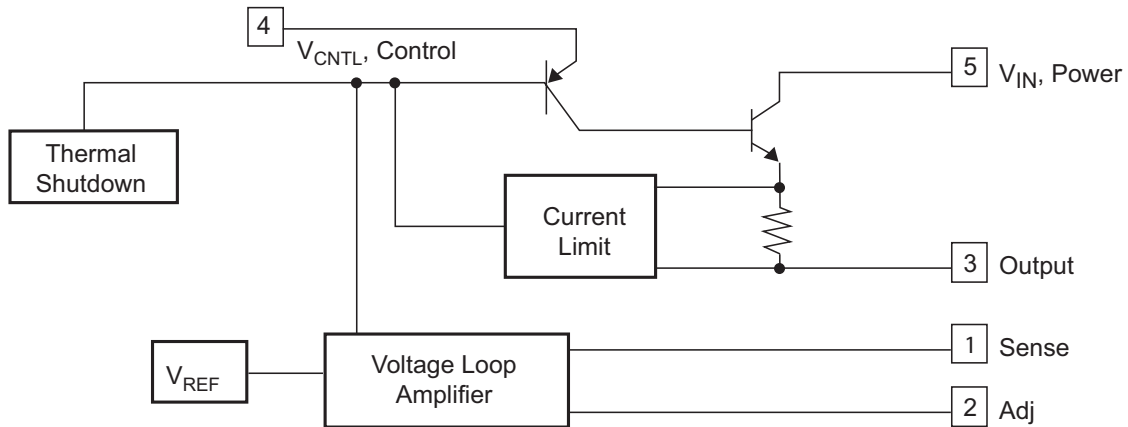
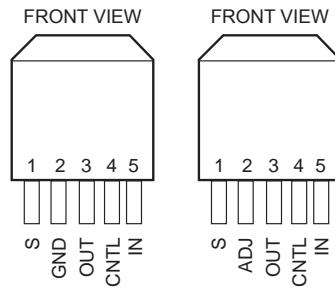

Figure 2. Applications Diagram

Pin Assignments



5-Lead Plastic TO-263
 $Q_{JC}=3^{\circ}\text{C}/\text{W}^*$
 Tab is out.

*With package soldered to 0.5 square inch copper area over backside ground plane or internal power plane, q_{JA} can vary from $30^{\circ}\text{C}/\text{W}$ to more than $40^{\circ}\text{C}/\text{W}$. Other mounting techniques can provide a thermal resistance lower than $30^{\circ}\text{C}/\text{W}$.

Figure 3. 5-Lead TO-263 Pin Assignments

Pin Definitions

Pin #	Name	Description
1	VSense	Remote Voltage Sense. Connect this pin to the load to permit true remote sensing and avoid trace drops.
2	ADJ/GND	Adjust or Ground. On the FAN1582, this pin forms the feedback to determine the output voltage. On the FAN1582-1.5 and -2.5, connect this pin to ground.
3	VOUT	Output Voltage. This pin and the tab are output.
4	VCNTL	Control Voltage. This pin draws small signal power to control the FAN1582 circuitry. Connect to a voltage higher than V_{IN} , as shown in Figure 1.
5	VIN	Input Voltage.

Absolute Maximum Ratings

Stresses exceeding the absolute maximum ratings may damage the device. The device may not function or be operable above the recommended operating conditions and stressing the parts to these levels is not recommended. In addition, extended exposure to stresses above the recommended operating conditions may affect device reliability. The absolute maximum ratings are stress ratings only.

Symbol	Parameter	Min.	Max.	Unit
V_{IN}	Input Voltage		7	V
V_{CNTL}	Control Voltage		13.2	V
T_J	Operating Junction Temperature Range	0	125	°C
T_L	Lead Temperature (soldering, 10 seconds)		300	°C
T_{STG}	Storage Temperature Range	-65	150	°C

Electrical Characteristics

$T_J=25^{\circ}\text{C}$, $V_{OUT} = V_S$, $V_{ADJ} = 0\text{V}$ unless otherwise specified. The • denotes specifications that apply over the specified operating temperature range.

Symbol	Parameter	Condition	Min.	Typ.	Max.	Units	
V_{REF}	Reference Voltage ⁽¹⁾	$V_{IN} = 2.0\text{V}$, $V_{CNTL} = 2.75\text{V}$, $I_{OUT} = 10\text{mA}$		1.243	1.250	1.257	V
	Reference Voltage ⁽¹⁾	$2.05\text{V} \leq V_{IN} \leq 5.5\text{V}$, $2.7\text{V} \leq V_{CNTL} \leq 12\text{V}$, $10\text{mA} \leq I_{OUT} \leq 3\text{A}$	•	1.237	1.250	1.263	V
V_{ADJ}	Adjustable Output Voltage	$3\text{V} \leq V_{IN} \leq 7\text{V}$ (Function of V_{OUT}), $10\text{mA} \leq I_{OUT} \leq 3\text{A}$	•	V_{REF}	1.5	5.7	V
V_{OUT}	Output Voltage ⁽²⁾	$3\text{V} \leq V_{IN} \leq 7\text{V}$, $10\text{mA} \leq I_{OUT} \leq 3\text{A}$	•	1.47	1.5	1.53	V
	Output Voltage ⁽³⁾	$5.1\text{V} \leq V_{IN} \leq 7\text{V}$, $10\text{mA} \leq I_{OUT} \leq 3\text{A}$	•	2.474	2.5	2.526	V
$REG_{(LINE)}$	Line Regulation ⁽⁴⁾⁽⁵⁾	$1.75\text{V} \leq V_{IN} \leq 5.5\text{V}$, $2.5\text{V} \leq V_{CNTL} \leq 12\text{V}$, $I_{OUT} = 10\text{mA}$	•		1	3	mV
$REG_{(LOAD)}$	Load Regulation ⁽⁴⁾⁽⁵⁾	$V_{IN} = 2.1\text{V}$, $V_{CNTL} = 2.75\text{V}$, $10\text{mA} \leq I_{OUT} \leq 3\text{A}$	•		1	5	mV
V_D	Dropout Voltage Minimum ($V_{CNTL}-V_{OUT}$)	$V_{IN} = 2.05\text{V}$, $\Delta V_{REF} = 1\%$, $I_{OUT} = 3\text{A}$	•		1.05	1.18	V
	Dropout Voltage Minimum ($V_{IN}-V_{OUT}$)	$V_{CNTL} = 2.75\text{V}$, $\Delta V_{REF} = 1\%$, $I_{OUT} = 3\text{A}$			0.4	0.5	V
	Dropout Voltage Minimum V_{IN}	$V_{CNTL} = 2.75\text{V}$, $\Delta V_{REF} = 1\%$, $I_{OUT} = 3\text{A}$	•		0.5	0.6	V
I_S	Current Limit	$V_{IN} = 2.05\text{V}$, $V_{CNTL} = 2.75\text{V}$	•	3.1			A
I_{CNTL}	Control Pin Current	$V_{IN} = 2.05\text{V}$, $V_{CNTL} = 2.75\text{V}$, $I_{OUT} = 10\text{mA}$	•		2	6	mA
I_{ADJ}	Adjust Pin Current ⁽¹⁾	$V_{IN} = 2.05\text{V}$, $V_{CNTL} = 2.75\text{V}$	•		50	120	μA
I_{MIN}	Minimum Load Current	$V_{IN} = 3.3\text{V}$, $V_{CNTL} = 5\text{V}$	•		5.0	10	mA
R_A	Ripple Rejection	$V_{IN} = 3.75\text{V}$, $V_{CNTL} = 3.75\text{V}$, $f=120\text{HZ}$, $C_{OUT} = 22\mu\text{F}$ Tantalum, $I_{OUT} = 1.5\text{A}$		60	80		dB
	Thermal Resitance	Junction-to-Case			3		°C/W
θ_{JC}	Thermal Regulation	$T_A = 25^{\circ}\text{C}$, 30ms Pulse			0.002	0.02	%/W
TSD	Thermal Shutdown				150		°C

Notes:

1. FAN1582 only.
2. FAN1582-1.5 only.
3. FAN1582-2.5 only.
4. See thermal regulation specifications for changes in output voltage due to heating effects. Load and line regulation are measured at a constant junction temperature by low duty cycle pulse testing.
5. Line and load regulation are guaranteed up to the maximum power dissipation (18W). Power dissipation is determined by input/output differential and the output current. Guaranteed maximum output power is not available over the full input/output voltage range.

Typical Performance Characteristics

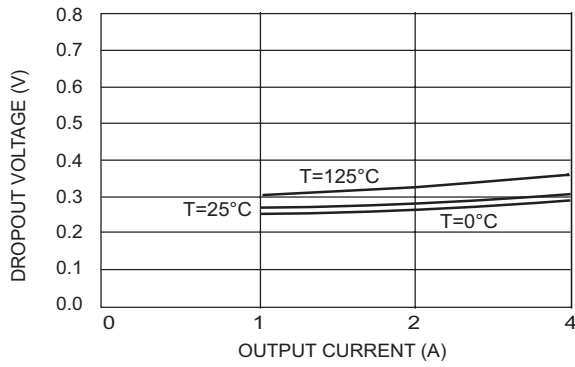

Figure 4. Dropout Voltage vs. Output Current

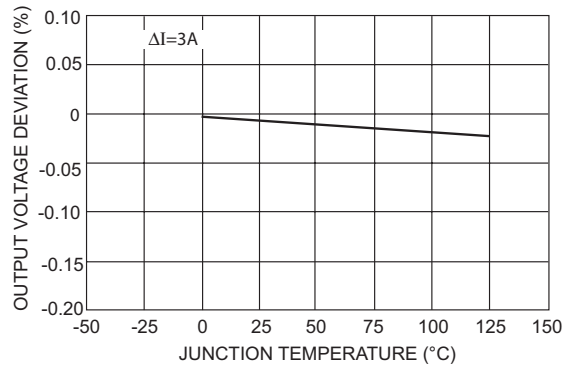

Figure 5. Load Regulation vs. Temperature

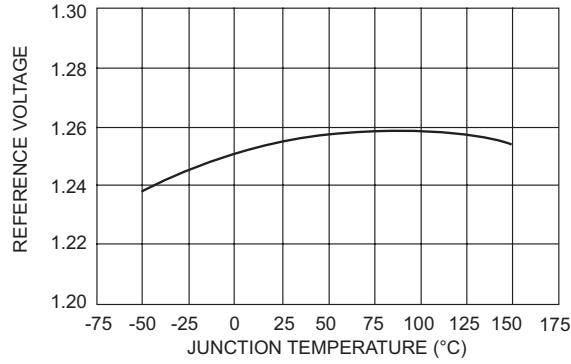

Figure 6. Reference Voltage vs. Temperature

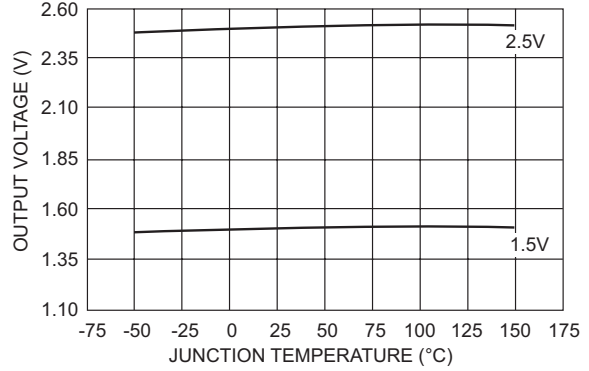

Figure 9. Output Voltage vs. Temperature

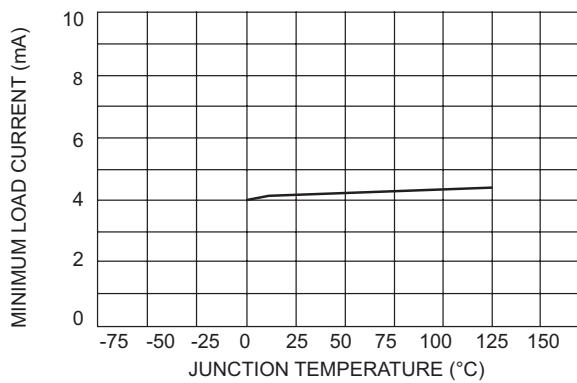

Figure 10. Minimum Load Current vs. Temperature

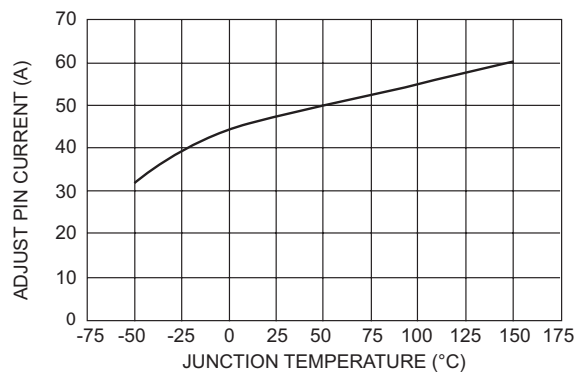

Figure 11. Adjust Pin Current vs. Temperature

Typical Performance Characteristics (Continued)

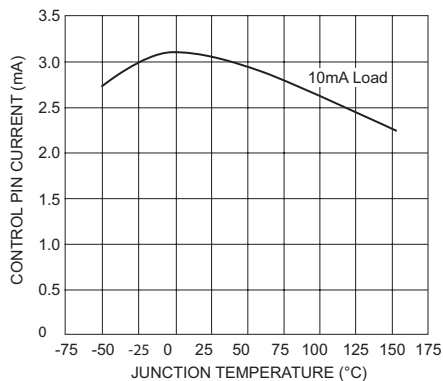

Figure 12. Control Pin Current vs. Temperature

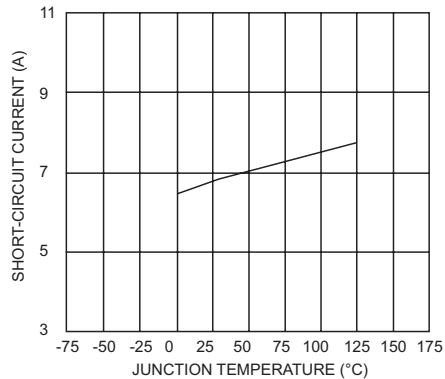

Figure 13. Short-Circuit Current vs. Temperature

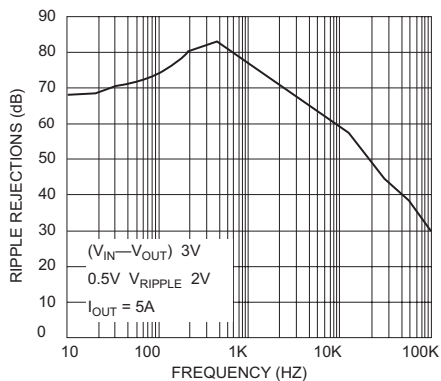

Figure 14. Ripple Rejection vs. Frequency

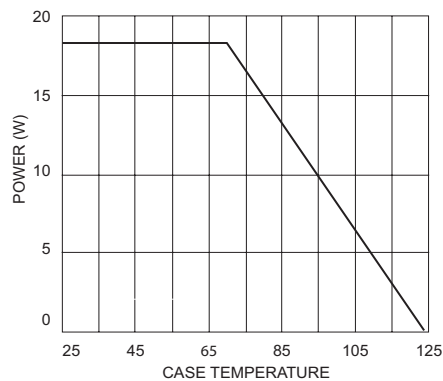

Figure 15. Maximum Power Dissipation

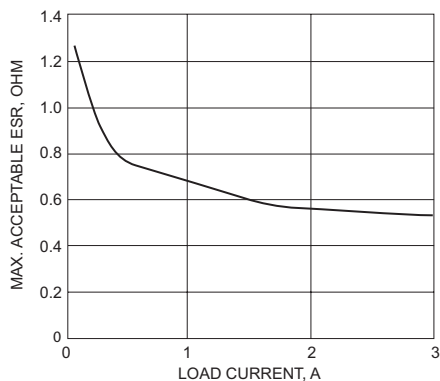

Figure 16. Stability

Detailed Operation

The FAN1582, FAN1582-1.5, and FAN1582-2.5 are three-terminal regulators optimized for GTL+ V_{TT} termination and logic applications. These devices are short-circuit protected and offer thermal shutdown to turn off the regulator when the junction temperature exceeds $\sim 150^{\circ}\text{C}$. The FAN1582 series provides low dropout voltage and fast transient response. Frequency compensation uses capacitors with low ESR while maintaining stability. This is critical in addressing the needs of low-voltage, high-speed microprocessor busses like GTL+.

V_{IN} and V_{CNTL} Functions

The FAN1582 utilizes a dual-supply approach to maximize efficiency. The collector of the power device is brought out to the V_{IN} pin to minimize internal power dissipation under high-current loads. V_{CNTL} provides power for the control circuitry and the drive for the output NPN transistor. V_{CNTL} should be at least 1.2V higher than the output voltage. Special care was taken to ensure there are no supply-sequencing problems. The output voltage does not turn on until both supplies are operating. If the control voltage comes up first, the output current is typically limited to about 3.0mA until the power input voltage comes up. If the power input voltage comes up first, the output does not turn on until the control voltage comes up. The output can never come up unregulated.

The FAN1582 can also be used as a single-supply device with the control and power inputs tied together. In this mode, the dropout is determined by the minimum control voltage.

Stability

The FAN1582 series requires an output capacitor as a part of the frequency compensation. It is recommended to use a 22 μF solid tantalum or a 100 μF aluminum electrolytic on the output to ensure stability. The frequency compensation of these devices optimizes the frequency response with low-ESR capacitors. In general, it is suggested to use capacitors with an ESR of $<0.3\Omega$. It is also recommended to use bypass capacitors, such as a 22 μF tantalum or a 100 μF aluminum, on the adjust pin of the FAN1582 for low ripple and fast transient response. If these bypassing capacitors are not used at the adjust pin, smaller values of output capacitors provide equally good results. A graph showing stability of output capacitance ESR vs. load current is shown in Figure 16.

Protection Diodes

In normal operation, the FAN1582 series does not require any protection diodes. For the FAN1582, internal resistors limit internal current paths on the adjust pin. Therefore, even with bypass capacitors on the adjust pin, no protection diode is needed to ensure device safety under short-circuit conditions.

A protection diode between the input and output pins is usually not needed. An internal diode between the input and the output pins on the FAN1582 series can handle microsecond surge currents of 50A to 100A. Even with large value output capacitors, it is difficult to obtain those values of surge currents in normal operation. Only with large values of output capacitance, such as 1000 μF to 5000 μF , and with the input pin instantaneously shorted to ground, can damage occur. Because a crowbar circuit at the input can generate those levels of current, a diode from output to input is recommended, as shown in Figure 16. Usually, normal power supply cycling or system “hot plugging and unplugging” does not generate current large enough to cause damage.

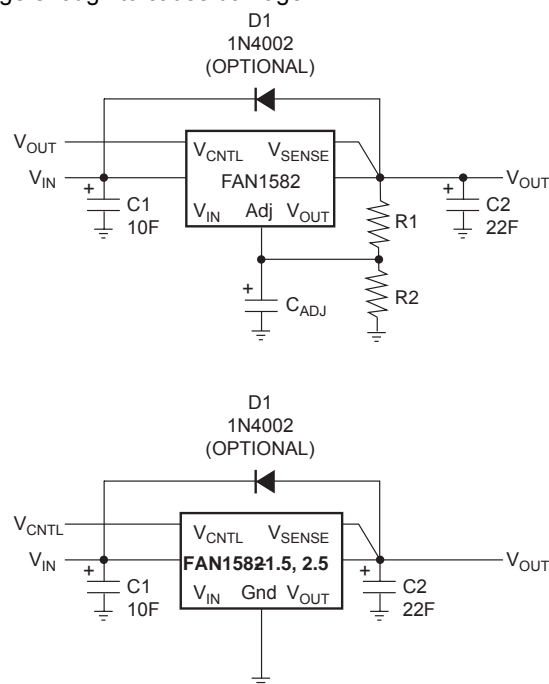

Figure 17. Optional Protection Diode

Ripple Rejection

In applications that require improved ripple rejection, a bypass capacitor from the adjust pin of the FAN1582 to ground reduces the output ripple by the ratio of $V_{OUT}/1.25\text{V}$. The impedance of the adjust pin capacitor at the ripple frequency should be less than the value of $R1$ (typically in the range of 100 Ω to 120 Ω) in the feedback divider network in Figure 17. Therefore, the value of the required adjust pin capacitor is a function of the input ripple frequency. For example, if $R1$ equals 100 Ω and the ripple frequency equals 120Hz, the adjust pin capacitor should be 22 μF . At 10kHz, only 0.22 μF is needed.

Output Voltage

The FAN1582 regulator develops a 1.25V reference voltage between the output pin and the adjust pin (see Figure 18). Placing a resistor R1 between these two terminals causes a constant current to flow through R1 and down through R2 to set the overall output voltage. Normally, this current is the specified minimum load current of 10mA.

The current out of the adjust pin adds to the current from R1 and is typically 50µA. Its output voltage contribution is small and only needs consideration when a very precise output voltage setting is required.

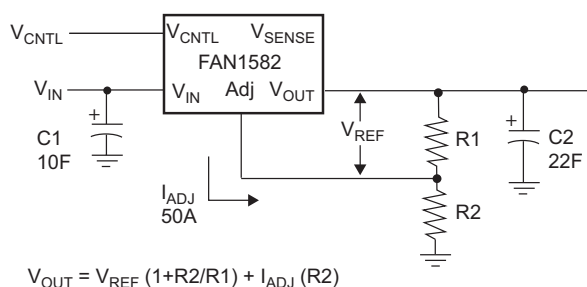

$$V_{OUT} = V_{REF} (1+R2/R1) + I_{ADJ} (R2)$$

Figure 18. Basic Regulator Circuit

Load Regulation

The FAN1582 family provides true remote sensing, eliminating output voltage errors due to trace resistance. To utilize remote sensing, connect the V_SENSE pin directly to the load, rather than at the V_OUT pin. If the load is more than one inch away from the FAN1582, it may be necessary to increase the load capacitance to ensure stability.

Thermal Considerations

The FAN1582 series protect themselves under overload conditions with internal power and thermal limiting circuitry. However, for normal continuous load conditions, do not exceed maximum junction temperature ratings. It is important to consider all sources of thermal resistance

from junction-to-ambient. These sources include the junction-to-case resistance, the case-to-heat sink interface resistance, and the heat sink resistance. Thermal resistance specifications have been developed to more accurately reflect device temperature and ensure safe operating temperatures. The Electrical Characteristics section provides a separate thermal resistance and maximum junction temperature for both the control circuitry and the power transistor. Calculate the maximum junction temperature for both sections to ensure that both thermal limits are met.

For example, look at using an FAN1582M-1.5 to generate 3A at 1.5V ± 2% from a 3.3V source (3.2V to 3.6V).

Assumptions:

- V_IN = 3.6V worst case
- V_OUT = 1.47V worst case
- I_OUT = 3A continuous
- T_A = 70°C
- Θ_JCA = 5°C/W (assuming both a heatsink and a thermally conductive material)

The power dissipation in this application is:

$$P_D = (V_{IN} - V_{OUT}) * (I_{OUT}) = (3.6-1.47) * (3) = 6.39W$$

From the specification table,

$$T_J = T_A + (P_D) * (\Theta_{CA} + \Theta_{JC}) = 70 + (6.39) * (5+3) = 121°C$$

The junction temperature is below the maximum rating.

Junction-to-case thermal resistance is specified from the IC junction to the bottom of the case directly below the die. This is the lowest resistance path for heat flow. Proper mounting ensures the best thermal flow from this area to the heat sink. Use of a thermally conductive material at the case-to-heat sink interface is recommended. Use a thermally conductive spacer if the case of the device must be electrically isolated and include its contribution to the total thermal resistance.

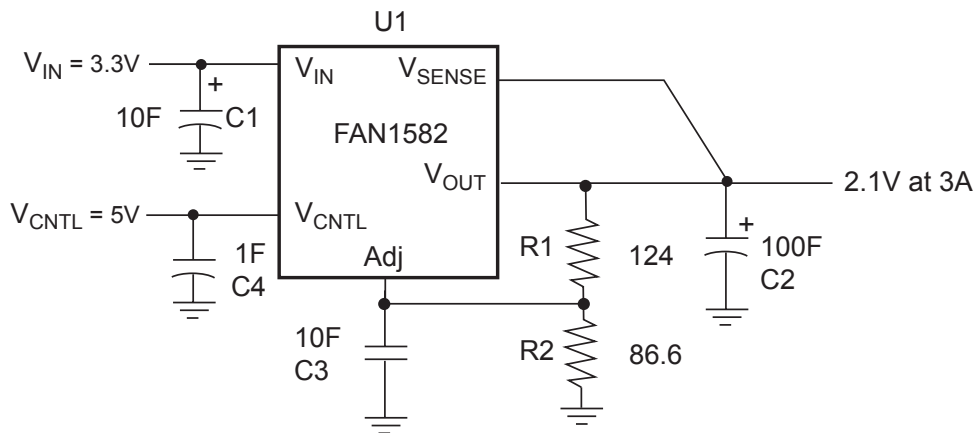

Figure 19. Application Circuit (FAN1582)

Table 1. Bill of Materials for Application Circuit for the FAN1582

Item	Quantity	Manufacturer	Part Number	Description
C1, C3	2	Xicon	L10V10	10 μ F, 10V Aluminum
C2	1	Xicon	L10V100	100 μ F, 10V Aluminum
C4	1	Any		1 μ F Ceramic
R1	1	Generic		124 Ω , 1%
R2	1	Generic		86.6 Ω , 1%
U1	1	Fairchild Semiconductor	FAN1582P	3A Regulator

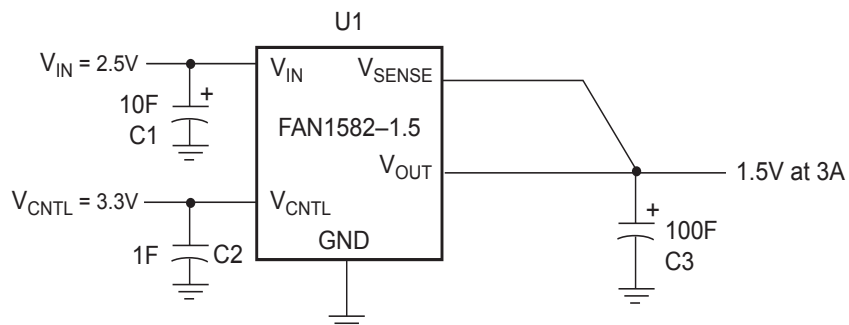

Figure 20. Application Circuit (FAN1582-1.5)

Table 2. Bill of Materials for Application Circuit for the FAN1582-1.5

Item	Quantity	Manufacturer	Part Number	Description
C1	1	Xicon	L10V10	10 μ F, 10V Aluminum
C2	1	Any		1 μ F Ceramic
C3	1	Xicon	L10V100	100 μ F, 10V Aluminum
U1	1	Fairchild Semiconductor	FAN1582P-1.5	3A Regulator

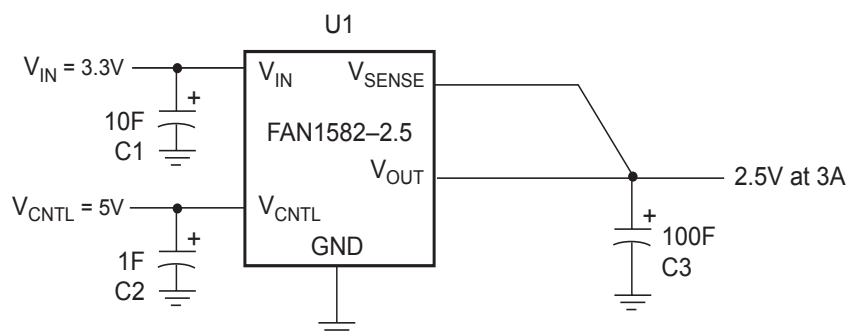

Figure 21. Application Circuit (FAN1582-2.5)

Table 3. Bill of Materials for Application Circuit for the FAN1582-2.5

Item	Quantity	Manufacturer	Part Number	Description
C1	1	Xicon	L10V10	10 μ F, 10V Aluminum
C2	1	Any		1 μ F Ceramic
C3	1	Xicon	L10V100	100 μ F, 10V Aluminum
U1	1	Fairchild Semiconductor	FAN1582P-2.5	3A Regulator

Mechanical Dimensions

Dimensions are in millimeters unless otherwise noted.

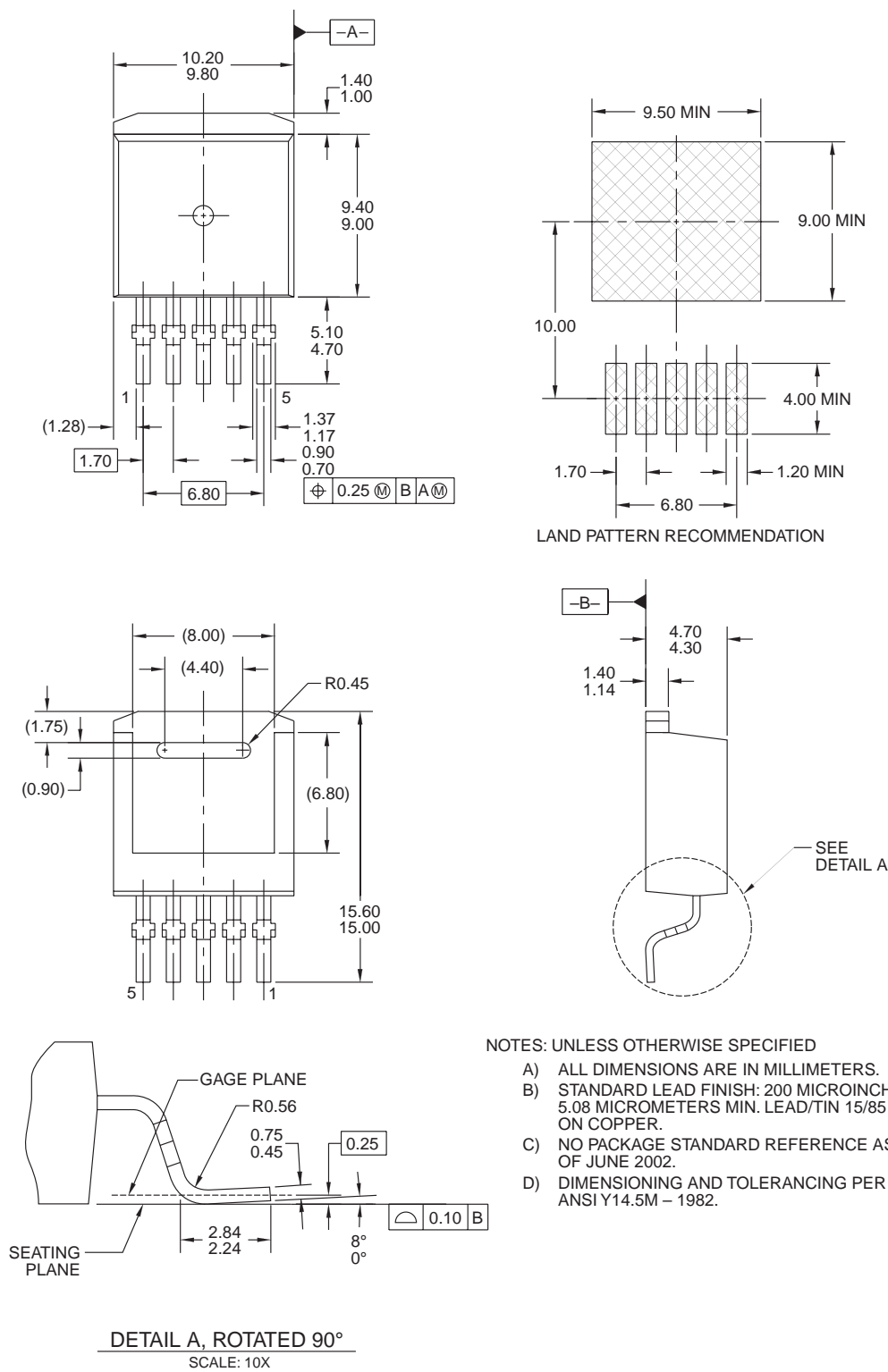



Figure 22. 5-Lead TO-263 Package



TRADEMARKS

The following are registered and unregistered trademarks Fairchild Semiconductor owns or is authorized to use and is not intended to be an exhaustive list of all such trademarks.

ACEx®	GlobalOptoisolator™	Power247®	SyncFET™
Across the board. Around the world.™	GTO™	PowerEdge™	TCM™
ActiveArray™	HiSeC™	PowerSaver™	The Power Franchise®
Bottomless™	i-Lo™	PowerTrench®	 ™
Build it Now™	ImpliedDisconnect™	Programmable Active Droop™	TinyBoost™
CoolFET™	IntelliMAX™	QFET®	TinyBuck™
CROSSVOLT™	ISOPLANAR™	QS™	TinyLogic®
CTL™	MICROCOUPLER™	QT Optoelectronics™	TINYOPTO™
Current Transfer Logic™	MicroPak™	Quiet Series™	TinyPower™
DOME™	MICROWIRE™	RapidConfigure™	TinyWire™
E ² CMOS™	MSX™	RapidConnect™	TruTranslation™
EcoSPARK®	MSXPro™	ScalarPump™	μSerDes™
EnSigna™	OCX™	SMART START™	UHC®
FACT Quiet Series™	OCXPro™	SPM®	UniFET™
FACT®	OPTOLOGIC®	STEALTH™	VCX™
FAST®	OPTOPLANAR®	SuperFET™	Wire™
FASTr™	PACMAN™	SuperSOT™-3	
FPS™	POP™	SuperSOT™-6	
FRFET®	Power220®	SuperSOT™-8	

DISCLAIMER

FAIRCHILD SEMICONDUCTOR RESERVES THE RIGHT TO MAKE CHANGES WITHOUT FURTHER NOTICE TO ANY PRODUCTS HEREIN TO IMPROVE RELIABILITY, FUNCTION, OR DESIGN. FAIRCHILD DOES NOT ASSUME ANY LIABILITY ARISING OUT OF THE APPLICATION OR USE OF ANY PRODUCT OR CIRCUIT DESCRIBED HEREIN; NEITHER DOES IT CONVEY ANY LICENSE UNDER ITS PATENT RIGHTS, NOR THE RIGHTS OF OTHERS. THESE SPECIFICATIONS DO NOT EXPAND THE TERMS OF FAIRCHILD'S WORLDWIDE TERMS AND CONDITIONS, SPECIFICALLY THE WARRANTY THEREIN, WHICH COVERS THESE PRODUCTS.

LIFE SUPPORT POLICY

FAIRCHILD'S PRODUCTS ARE NOT AUTHORIZED FOR USE AS CRITICAL COMPONENTS IN LIFE SUPPORT DEVICES OR SYSTEMS WITHOUT THE EXPRESS WRITTEN APPROVAL OF FAIRCHILD SEMICONDUCTOR CORPORATION.

As used herein:

- Life support devices or systems are devices or systems which, (a) are intended for surgical implant into the body, or (b) support or sustain life, and (c) whose failure to perform when properly used in accordance with instructions for use provided in the labeling, can be reasonably expected to result in significant injury to the user.
- A critical component is any component of a life support device or system whose failure to perform can be reasonably expected to cause the failure of the life support device or system, or to affect its safety or effectiveness.

PRODUCT STATUS DEFINITIONS

Definition of Terms

Datasheet Identification	Product Status	Definition
Advance Information	Formative or In Design	This datasheet contains the design specifications for product development. Specifications may change in any manner without notice.
Preliminary	First Production	This datasheet contains preliminary data; supplementary data will be published at a later date. Fairchild Semiconductor reserves the right to make changes at any time without notice to improve design.
No Identification Needed	Full Production	This datasheet contains final specifications. Fairchild Semiconductor reserves the right to make changes at any time without notice to improve design.
Obsolete	Not In Production	This datasheet contains specifications on a product that has been discontinued by Fairchild semiconductor. The datasheet is printed for reference information only.

Rev. I24

Looking for pricing, stock, or lifecycle information?

Click below to explore more details on WIN SOURCE:

- ⊖ [View 1582M25 on WIN SOURCE](#)
- ⊖ [Fairchild/ON Semiconductor Information](#)

Optimize Your Supply Chain with WIN SOURCE Solutions

- ✓ Global Sourcing Solution
- ✓ Obsolete Management
- ✓ Cost Control Management
- ✓ Shortage Management
- ✓ Alternative Solution
- ✓ Excess Inventory Management