



**THE DATASHEET OF
LM74720QDRRRQ1**



LM74720-Q1 Low IQ Automotive Ideal Diode Controller with Active Rectification and Load Dump Protection

1 Features

- AEC-Q100 qualified with the following results
 - Device temperature grade 1:
 - 40°C to +125°C ambient operating temperature range
 - Device HBM ESD classification level 2
 - Device CDM ESD classification level C4B
- 3-V to 65-V input range
- Reverse input protection down to –65 V
- Low quiescent current, 35 μ A (max) in operation
- Low 3.3- μ A (max) shutdown current (EN = Low)
- Ideal diode operation with 17-mV A to C forward voltage drop regulation
- Drives external back-to-back N-Channel MOSFETs
- Integrated 29-mA boost regulator
- Fast response to reverse current blocking: 0.5 μ s
- Active rectification up to 100 kHz
- Adjustable overvoltage protection
- Meets automotive ISO7637 transient requirements with a suitable TVS diode
- Available in space saving 12-pin WSON package
- Pin-to-pin compatible with [LM74721-Q1](#)

2 Applications

- Automotive battery protection
 - [ADAS domain controller](#)
 - [Premium audio amplifier](#)
 - [Head unit](#)
 - [Gateway](#)

3 Description

The LM74720-Q1 ideal diode controller drives and controls external back-to-back N-Channel MOSFETs to emulate an ideal diode rectifier with power path ON/OFF control and overvoltage protection. The wide input supply of 3 V to 65 V allows protection and control of 12-V and 24-V automotive battery powered ECUs. The device can withstand and protect the loads from negative supply voltages down to –65 V. An integrated ideal diode controller (GATE) drives the first MOSFET to replace a Schottky diode for reverse input protection and output voltage holdup. A strong boost regulator with fast turn ON and OFF comparators ensures robust and efficient MOSFET switching performance during automotive testing such as ISO16750 or LV124 where an ECU is subjected to input short interruptions and AC superimpose input signals up to 100-kHz frequency. Low Quiescent Current 35 μ A (maximum) in operation enables always ON system designs. With a second MOSFET in the power path, the device allows load disconnect control using EN pin. Quiescent current reduces to 3.3 μ A (maximum) with EN low. The device features an adjustable overvoltage cut-off protection feature for load dump protection.

Device Information

PART NUMBER	PACKAGE ⁽¹⁾	BODY SIZE (NOM)
LM74720-Q1	WSON (12)	3.0 mm × 3.0 mm

(1) For all available packages, see the orderable addendum at the end of the data sheet.

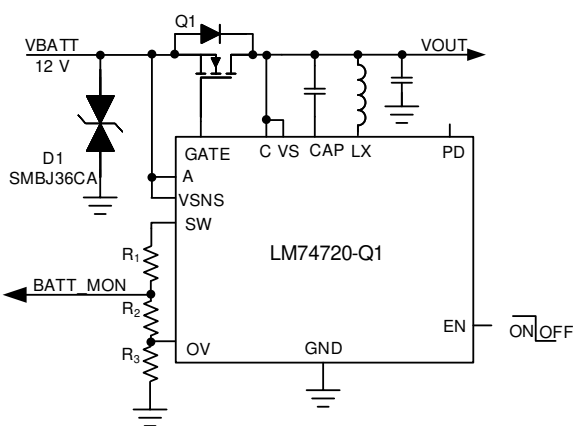

Low IQ Ideal Diode

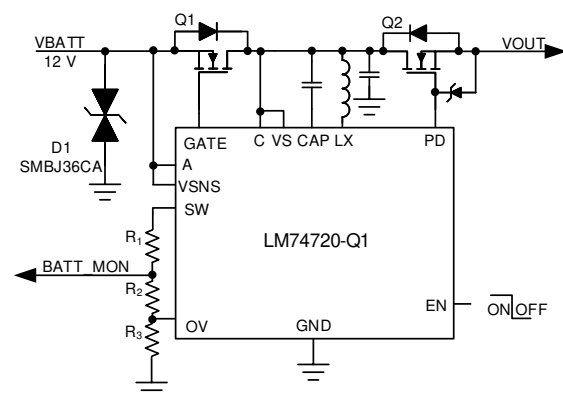

Low IQ Ideal Diode with Switched Output



Table of Contents

1 Features	1	9.1 Application Information.....	14
2 Applications	1	9.2 Typical 12-V Reverse Battery Protection Application.....	14
3 Description	1	9.3 Do's and Don'ts.....	22
4 Revision History	2	10 Power Supply Recommendations	23
5 Pin Configuration and Functions	3	10.1 Transient Protection.....	23
6 Specifications	4	10.2 TVS Selection for 12-V Battery Systems.....	24
6.1 Absolute Maximum Ratings.....	4	10.3 TVS Selection for 24-V Battery Systems.....	24
6.2 ESD Ratings.....	4	11 Layout	25
6.3 Recommended Operating Conditions.....	4	11.1 Layout Guidelines.....	25
6.4 Thermal Information.....	5	11.2 Layout Example.....	25
6.5 Electrical Characteristics.....	5	12 Device and Documentation Support	26
6.6 Switching Characteristics.....	6	12.1 Third-Party Products Disclaimer.....	26
6.7 Typical Characteristics.....	7	12.2 Receiving Notification of Documentation Updates..	26
7 Parameter Measurement Information	9	12.3 Support Resources.....	26
8 Detailed Description	10	12.4 Trademarks.....	26
8.1 Overview.....	10	12.5 Electrostatic Discharge Caution.....	26
8.2 Functional Block Diagram.....	10	12.6 Glossary.....	26
8.3 Feature Description.....	11	13 Mechanical, Packaging, and Orderable Information	26
8.4 Device Functional Mode (Shutdown Mode).....	13		
9 Application and Implementation	14		

4 Revision History

NOTE: Page numbers for previous revisions may differ from page numbers in the current version.

Changes from Revision A (January 2022) to Revision B (March 2022)	Page
• Changed status from "Advance Information" to "Production Data".....	1

Changes from Revision * (September 2021) to Revision A (January 2022)	Page
• Updated the <i>Electrical Characteristics</i> and <i>Switching Characteristics</i> with specification limits.....	4
• Added the <i>Typical Characteristics</i> section.....	7

5 Pin Configuration and Functions

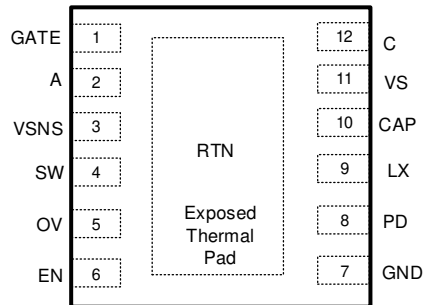

Figure 5-1. WSON 12-Pin DRR Transparent Top View

Table 5-1. Pin Functions

NAME	PIN		TYPE	DESCRIPTION
	LM74720-Q1	DRR-12 (WSON)		
GATE	1	1	O	Diode controller gate drive output. Connect to the GATE of the external MOSFET.
A	2	2	I	Anode of the ideal diode. Connect to the source of the external MOSFET.
VSNS	3	3	I	Voltage sensing input
SW	4	4	I	Voltage sensing disconnect switch terminal. VSNS and SW are internally connected through a switch. Use SW as the top connection of the battery sensing or OV resistor ladder network. When EN is pulled low, the switch is OFF, disconnecting the resistor ladder from the battery line, thereby cutting off the leakage current. If the internal disconnect switch between VSNS and SW is not used, then short them together and connect to C pin.
OV	5	5	I	Adjustable overvoltage threshold input. Connect a resistor ladder across SW to OV terminal. When the voltage at OV exceeds the overvoltage cut-off threshold, then the PD is pulled low turning OFF the HSFET. PD is driven high when the sense voltage goes below the OV falling threshold.
EN	6	6	I	EN Input. Connect to A or C pin for always ON operation. In this mode, the device consumes an IQ of 35 μ A (maximum). Can be driven externally from a micro controller I/O. Pulling the pin low below 0.5 V enters the device in low Iq shutdown mode.
GND	7	7	G	Connect to the system ground plane.
PD	8	8	O	Pull down connection for the external load disconnect FET. Connect to the GATE of the external FET to PD pin. Leave PD pin floating if the load disconnect FET is not used.
LX	9	9	I	Switch node of the internal boost regulator. This node must be kept small on the PCB for good performance and low EMI. Connect the boost inductor between this pin and the DRAIN connection of the external FET.
CAP	10	10	O	Boost Regulator Output. This pin is used to provide a drive voltage to the gate driver of the ideal diode stage as well as drive supply for the HSFET. Connect a 1- μ F capacitor between this pin and the VS pin.
VS	11	11	I	Supply voltage pin
C	12	12	I	Cathode of the ideal diode. Connect to the DRAIN of the external MOSFET. The voltage sensed at this pin is used to control the external MOSFET GATE.
RTN	Thermal Pad	—	—	Leave exposed pad floating. Do not connect to GND plane.

6 Specifications

6.1 Absolute Maximum Ratings

over operating free-air temperature range (unless otherwise noted)⁽¹⁾

		MIN	MAX	UNIT
Input Pins	A to GND	-65	70	V
	VS, C to GND	-0.3	70	
	VSNS, SW, EN, OV to GND, $V_{(A)} > 0$ V	-0.3	70	
	VSNS, SW, EN, OV to GND, $V_{(A)} \leq 0$ V	$V_{(A)}$	$(70 + V_{(A)})$	
	RTN to GND	-65	0.3	mA
	I_{VSNS}, I_{SW}	-1	10	
	$I_{EN}, I_{OV}, V_{(A)} > 0$ V	-1		
	$I_{EN}, I_{OV}, V_{(A)} \leq 0$ V	Internally limited		
Output Pins	CAP to C	-0.3	15.9	V
	CAP to A	-0.3	85	
	GATE to A	-0.3	15	
	LX, CAP, PD to GND	-0.3	85	
Output to Input Pins	C to A	-5	85	
Operating junction temperature, T_J ⁽²⁾		-40	150	°C
Storage temperature, T_{stg}		-40	150	

- Operation outside the Absolute Maximum Ratings may cause permanent device damage. Absolute Maximum Ratings do not imply functional operation of the device at these or any other conditions beyond those listed under Recommended Operating Conditions. If used outside the Recommended Operating Conditions but within the Absolute Maximum Ratings, the device may not be fully functional, and this may affect device reliability, functionality, performance, and shorten the device lifetime
- High junction temperatures degrade operating lifetimes. Operating lifetime is de-rated for junction temperatures greater than 125°C.

6.2 ESD Ratings

			VALUE	UNIT	
$V_{(ESD)}$	Electrostatic discharge	Human body model (HBM), per AEC Q100-002 ⁽¹⁾	±2000	V	
		Charged device model (CDM), per AEC Q100-011	Corner pins (GATE, EN, GND, C)		±750
			Other pins		±500

- AEC-Q100-002 indicates that HBM stressing shall be in accordance with the ANSI/ESDA/JEDEC JS-001 specifications.

6.3 Recommended Operating Conditions

over operating free-air temperature range (unless otherwise noted)⁽¹⁾

		MIN	NOM	MAX	UNIT
Input Pins	A to GND	-60		65	V
	C to GND			65	
	EN to GND	-60		65	
External capacitance	A	0.1			µF
	VS, CAP to C	1			µF
External Inductor	LX	100			µH
External MOSFET max V_{GS} rating	GATE to A	15			V
T_J	Operating junction temperature range ⁽²⁾	-40		150	°C

- Recommended Operating Conditions are conditions under which the device is intended to be functional. For specifications and test conditions, see [Electrical Characteristics](#).

- (2) High junction temperatures degrade operating lifetimes. Operating lifetime is de-rated for junction temperatures greater than 125°C.

6.4 Thermal Information

THERMAL METRIC ⁽¹⁾		LM74720-Q1	UNIT
		DRR (WSON)	
		12 PINS	
$R_{\theta JA}$	Junction-to-ambient thermal resistance	61.6	°C/W
$R_{\theta JC(top)}$	Junction-to-case (top) thermal resistance	50	°C/W
$R_{\theta JB}$	Junction-to-board thermal resistance	32.7	°C/W
Ψ_{JT}	Junction-to-top characterization parameter	1.4	°C/W
Ψ_{JB}	Junction-to-board characterization parameter	32.7	°C/W
$R_{\theta JC}$	Junction-to-case (bottom) thermal resistance	6.9	°C/W

- (1) For more information about traditional and new thermal metrics, see the Semiconductor and IC Package Thermal Metrics application report, SPRA953.

6.5 Electrical Characteristics

$T_J = -40^\circ\text{C}$ to $+125^\circ\text{C}$; typical values at $T_J = 25^\circ\text{C}$, $V_{(A)} = V_{(VS)} = 12\text{ V}$, $C_{(CAP)} = 1\ \mu\text{F}$, $V_{(EN)} = 2\text{ V}$, over operating free-air temperature range (unless otherwise noted)

PARAMETER		TEST CONDITIONS	MIN	TYP	MAX	UNIT
SUPPLY VOLTAGE						
$V_{(A\ POR)}$	VA POR Rising threshold		3.1	3.4	3.85	V
	VA POR Falling threshold		2.2	2.6	2.9	V
$V_{(VS)}$	Minimum Voltage at VS				3	V
$I_{(SHDN)}$	Shutdown Supply Current	$V_{(EN)} = 0\text{ V}$		1.5	3.3	μA
$I_{(Q)}$	Total System Quiescent Current	$V_{(EN)} = 2\text{ V}$, Active Rectifier Controller In Regulation, $-40^\circ\text{C} \leq T_J \leq +85^\circ\text{C}$		27	32	μA
		$V_{(EN)} = 2\text{ V}$, Active Rectifier Controller In Regulation, $-40^\circ\text{C} \leq T_J \leq +125^\circ\text{C}$		27	35	μA
ENABLE INPUT						
$V_{(EN_IH)}$	Enable input high threshold				2	V
$V_{(EN_IL)}$	Enable input low threshold		0.5	0.85	1.2	
$V_{(EN_Hys)}$	Enable Hysteresis			380		mV
$I_{(EN)}$	Enable sink current	$V_{(EN)} = 12\text{ V}$		52	155	nA
V_{ANODE} to $V_{CATHODE}$ ($V_A - C$)						
$V_{(AC\ REG)}$	Regulated Forward $V_{(AC)}$ Threshold		9	16.4	22.7	mV
$V_{(AC_FWD)}$	$V_{(AC)}$ threshold from RCB to oFCB		75	105	140	mV
$V_{(AC_REV)}$	$V_{(AC)}$ threshold for reverse current blocking		-12	-5.65	-1.3	mV
GATE DRIVE						
$V_{(GATE)} - V_{(A)}$		$3\text{ V} < V_{(VS)} < 65\text{ V}$	9.5		13	V
$I_{(GATE)}$	Peak sink current	$V_{(A)} - V_{(C)} = -20\text{ mV}$		2.5		A
	Regulation max sink current	$V_{(A)} - V_{(C)} = 0\text{ V}$, $V_{(GATE)} - V_{(A)} = 5\text{ V}$	14	26	39	μA
R_{GATE}	GATE pulldown resistance	$V_{(A)} - V_{(C)} = -20\text{ mV}$, $V_{(GATE)} - V_{(A)} = 100\text{ mV}$		1.2		Ω
BOOST REGULATOR						
$V_{(CAP)} - V_{(VS)}$	Boost output rising threshold			13	15.5	V
	Hysteresis			1.1		V
$I_{(CAP)}$	Boost load capacity	$V_{(CAP)} - V_{(VS)} = 7.5\text{ V}$		29		mA

6.5 Electrical Characteristics (continued)

$T_J = -40^{\circ}\text{C}$ to $+125^{\circ}\text{C}$; typical values at $T_J = 25^{\circ}\text{C}$, $V_{(A)} = V_{(VS)} = 12\text{ V}$, $C_{(CAP)} = 1\ \mu\text{F}$, $V_{(EN)} = 2\text{ V}$, over operating free-air temperature range (unless otherwise noted)

PARAMETER		TEST CONDITIONS	MIN	TYP	MAX	UNIT
$I_{(LX)}$	Peak inductor current limit threshold	$V_{(VS)} = 12\text{ V}$	110	140	170	mA
		$V_{(VS)} = 3\text{ V}$			210	mA
$R_{(LX)}$	Low side switch On-Resistance		1.3	2.7	5.1	Ω
BATTERY SENSING (VSNS, SW) AND OVER VOLTAGE DETECTION (OV, PD)						
$R_{(SW)}$	Battery sensing disconnect switch resistance		104	226	430	Ω
$V_{(OVR)}$	Overvoltage threshold input, rising		1.13	1.231	1.33	V
$V_{(OVF)}$	Overvoltage threshold input, falling		1.03	1.125	1.215	V
$V_{(OV_Hys)}$	OV Hysteresis			110		mV
$I_{(OV)}$	OV Input leakage current	$0\text{ V} < V_{(OV)} < 5\text{ V}$		50	110	nA
$I_{(PD_SRC)}$	Pullup current	$3\text{ V} < V_{(VS)} < 65\text{ V}$	43	50	60	μA
$I_{(PD_SINK)}$	Peak pulldown current	$V_{(OV)} > V_{(OVR)}$	55	88	117	mA
	DC pulldown current		7	10	14	mA
CATHODE (C)						
$I_{(C)}$	CATHODE sink current	$V_{(A)} = 12\text{ V}$, $V_{(A)} - V_{(C)} = -100\text{ mV}$		8.5	15	μA
		$V_{(A)} = -14\text{ V}$, $V_{(C)} = 14\text{ V}$		10.6	18	μA

6.6 Switching Characteristics

$T_J = -40^{\circ}\text{C}$ to $+125^{\circ}\text{C}$; typical values at $T_J = 25^{\circ}\text{C}$, $V_{(A)} = V_{(VS)} = 12\text{ V}$, $C_{(CAP)} = 1\ \mu\text{F}$, $V_{(EN)} = 2\text{ V}$, over operating free-air temperature range (unless otherwise noted)

PARAMETER		TEST CONDITIONS	MIN	TYP	MAX	UNIT
EN_{TDLY}	A (low to high) to GATE Turn On delay	$V_{(A)} \uparrow V_{(A\text{ POR})}$ to $V_{(GATE-A)} > 5\text{ V}$, $C_{(GATE-A)} = 10\text{ nF}$,			200	μs
$t_{GATE_OFF(DLY)}$	Reverse voltage detection to Gate Turn Off delay	$V_{(A)} - V_{(C)} = +30\text{ mV}$ to -100 mV , $V_{(GATE)} - V_{(A)} < 1\text{ V}$, $C_{(GATE-A)} = 10\text{ nF}$		0.47	0.81	μs
$t_{GATE_ON(DLY)}$	Forward voltage detection to Gate Turn On delay	$V_{(A)} - V_{(C)} = -100\text{ mV}$ to $+700\text{ mV}$, $V_{(GATE)} - V_{(A)} > 5\text{ V}$, $C_{(GATE-A)} = 10\text{ nF}$		1.9	2.9	μs
$t_{EN_OFF(DLY)PD}$	EN to PD Delay	EN \downarrow to PD \downarrow		6.5	12	μs
$t_{OV_OFF(DLY)PD}$	OV to PD Delay	OV \uparrow to PD \downarrow		0.9	1.5	μs
t_{PD_PK}	Peak Pull Down duration	$I_{(PD_SINK, PK)} \uparrow$ to $I_{(PD_SINK, DC)} \downarrow$	11	38	65	μs

6.7 Typical Characteristics

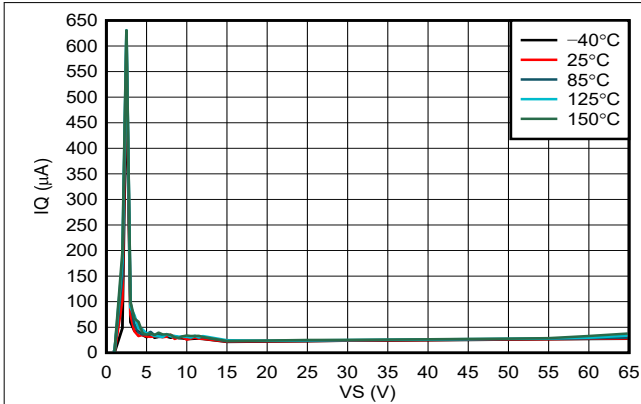

Figure 6-1. Operating Quiescent Current vs Supply Voltage

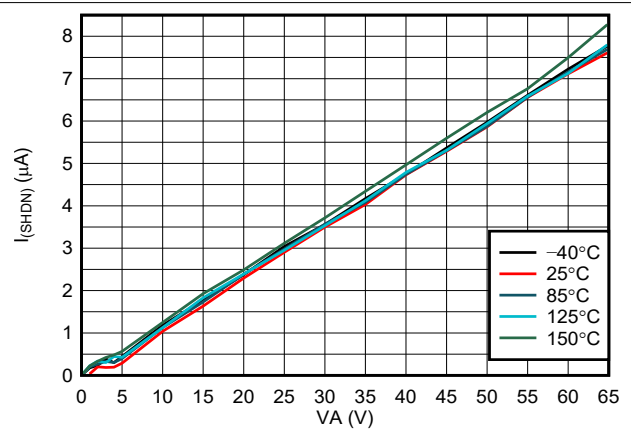

Figure 6-2. Shutdown Supply Current vs Supply Voltage

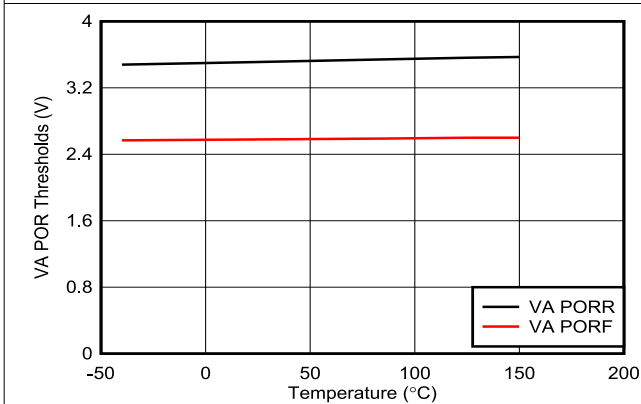

Figure 6-3. VA POR Threshold vs Temperature

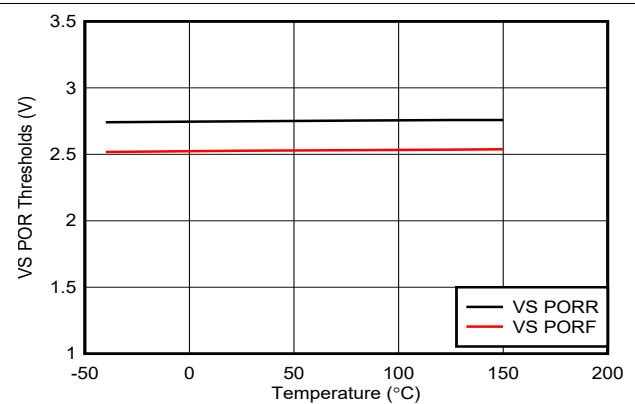

Figure 6-4. VS POR Threshold vs Temperature

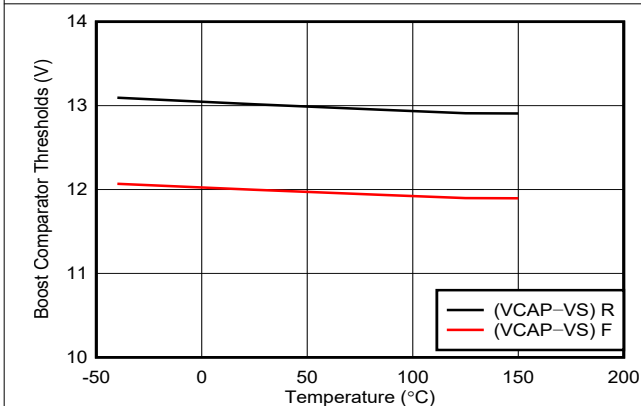

Figure 6-5. Boost Comparator Threshold vs Temperature

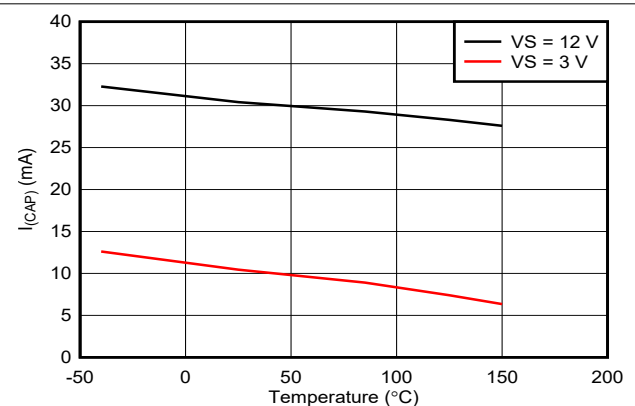

Figure 6-6. Boost Loading Capacity vs Temperature

6.7 Typical Characteristics (continued)

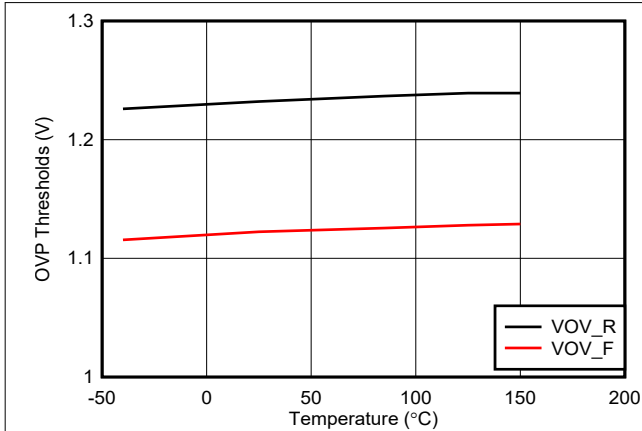

Figure 6-7. OV Threshold vs Temperature

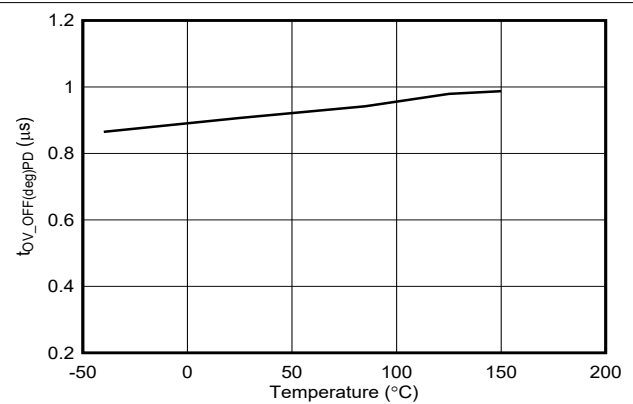

Figure 6-8. PD Turn-off Delay During OV

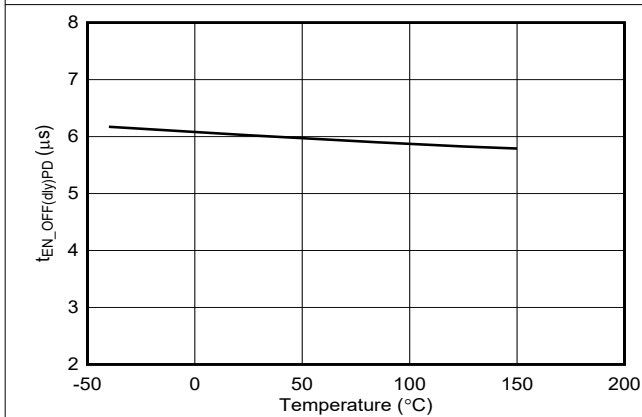

Figure 6-9. PD Turn-off Delay During EN

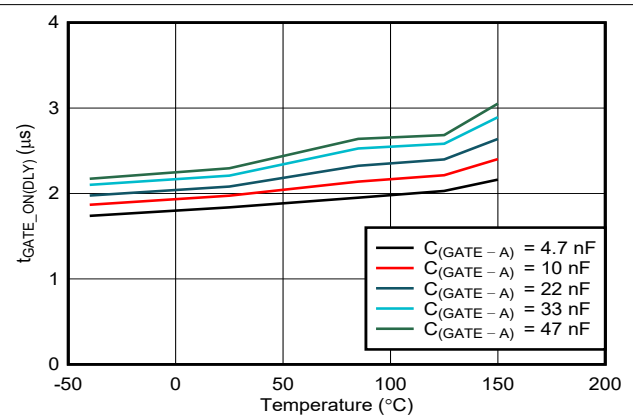

Figure 6-10. Forward Turn-on Delay vs Temperature

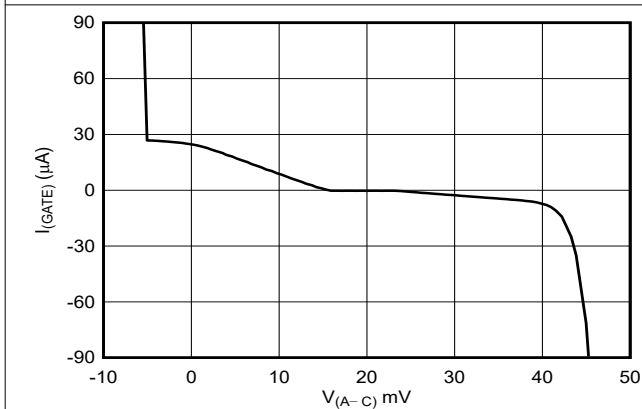

Figure 6-11. Gate Current vs Forward Voltage Drop

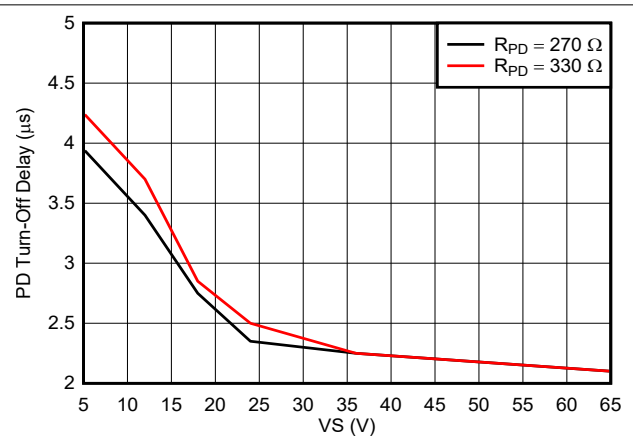

Figure 6-12. PD Turn-off Delay vs Supply Voltage

7 Parameter Measurement Information

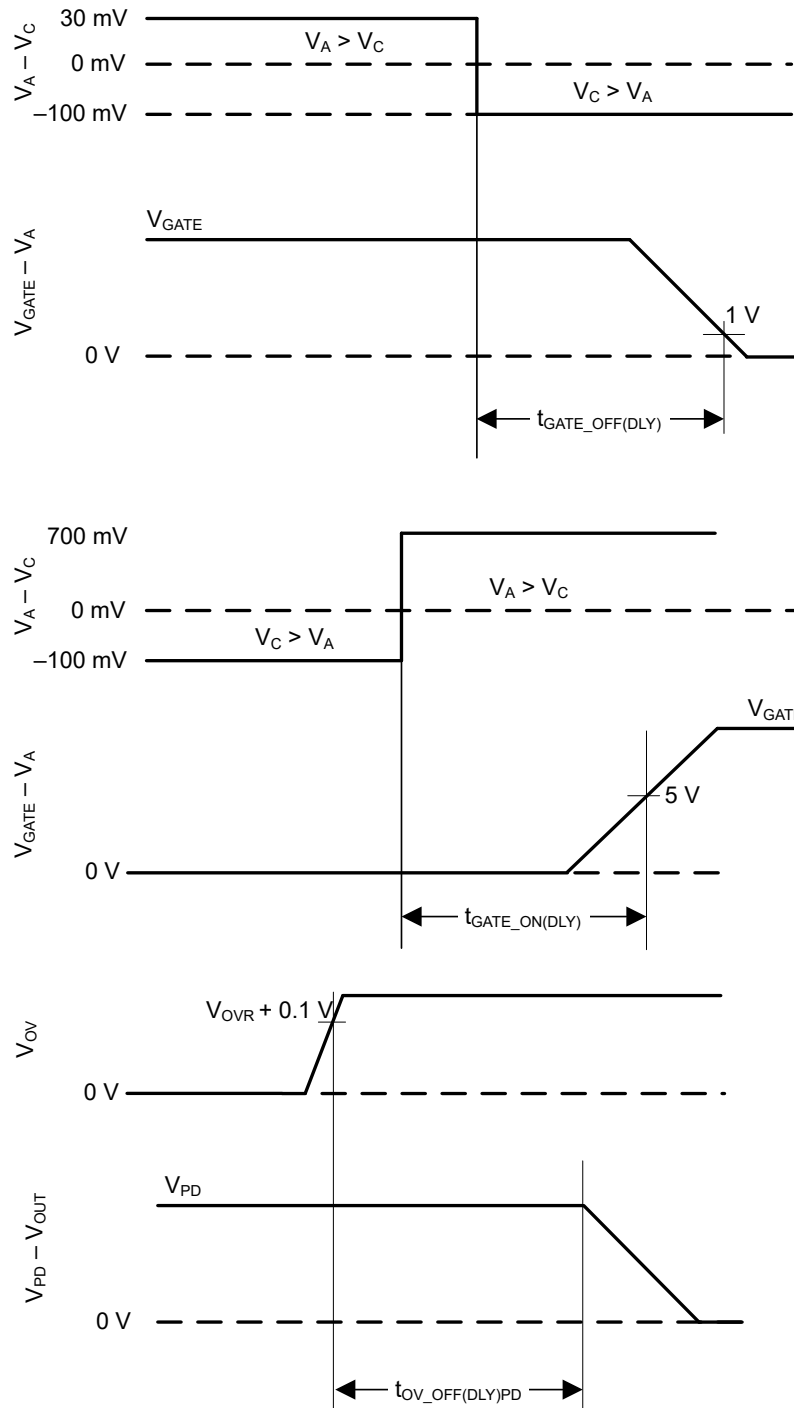

Figure 7-1. Timing Waveforms

8 Detailed Description

8.1 Overview

The LM74720-Q1 ideal diode controller drives and controls external back-to-back N-Channel MOSFETs to emulate an ideal diode rectifier with power path ON and OFF control and overvoltage protection. The wide input supply of 3 V to 65 V allows protection and control of 12-V and 24-V automotive battery powered ECUs. IQ during operation (EN = High) is <math>< 35 \mu\text{A}</math> and <math>< 3.3 \mu\text{A}</math> during shutdown mode (EN = Low). The device can withstand and protect the loads from negative supply voltages down to -65 V . An integrated ideal diode controller (GATE) drives the first MOSFET to replace a Schottky diode for reverse input protection and output voltage holdup. A strong 29-mA boost regulator and short turn-ON and turn-OFF delay times of comparators ensures fast transient response ensuring robust and efficient MOSFET switching performance during automotive testing such as ISO16750 or LV124 where an ECU is subjected to input short interruptions and AC superimpose input signals up to 100-kHz frequency. The device features an adjustable over voltage cut-off protection feature for load dump protection.

The LM74720-Q1 controls the GATE of the MOSFET to regulate the forward voltage drop at 17 mV. The linear regulation scheme in these devices enables graceful control of the GATE voltage and turns off of the MOSFET during a reverse current event and ensures zero DC reverse current flow.

Low quiescent current (<math>< 35 \mu\text{A}</math>) in operation enables always ON system designs. With a second MOSFET in the power path, the device allows load disconnect control using EN pin. Quiescent current reduces to $3.3 \mu\text{A}$ with EN low.

8.2 Functional Block Diagram

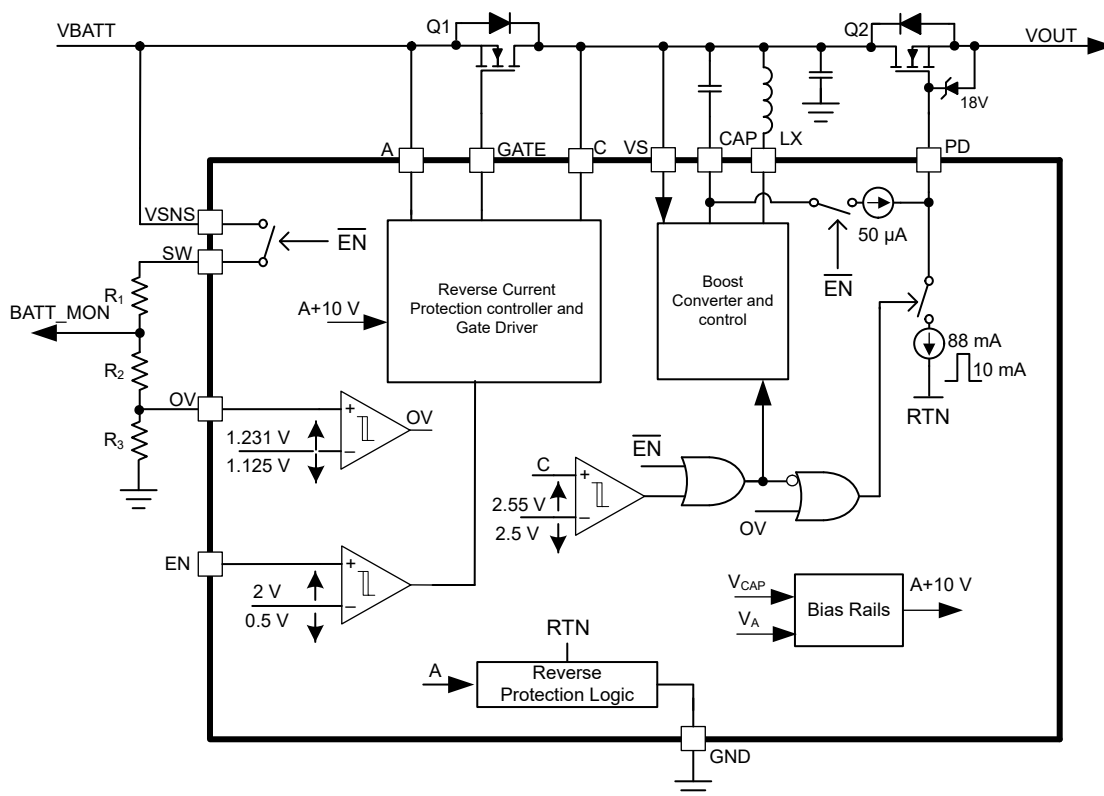

8.3 Feature Description

8.3.1 Dual Gate Control (GATE, PD)

The LM74720-Q1 features two separate gate control and driver outputs. That is, GATE and PD to drive back-to-back N-channel MOSFETs.

8.3.1.1 Reverse Battery Protection (A, C, GATE)

A, C, GATE comprises of Ideal Diode stage. Connect the Source of the external MOSFET to A, Drain to C and Gate to GATE pin. The LM74720-Q1 has integrated reverse input protection down to -65 V .

In LM74720-Q1, the voltage drop across the MOSFET is continuously monitored between the A and C pins, and the GATE to A voltage is adjusted as needed to regulate the forward voltage drop at 17 mV (typical) for LM74720-Q1. This closed loop regulation scheme enables graceful turn-off of the MOSFET during a reverse current event and ensures zero DC reverse current flow. This scheme ensures robust performance during slow input voltage ramp down tests. Along with the linear regulation amplifier scheme, the LM74720-Q1 also integrates a fast reverse voltage comparator. When the voltage drop across A and C reaches $V_{(AC_REV)}$ threshold, then the GATE goes low within $0.5\text{ }\mu\text{s}$ (typical). This fast reverse voltage comparator scheme ensures robust performance during fast input voltage ramp down tests such as input micro-shorts. The external MOSFET is turned back ON when the voltage across A and C hits $V_{(AC_FWD)}$ threshold within $1.9\text{ }\mu\text{s}$ (typical). For ideal diode only designs, connect LM74720-Q1 as shown in [Figure 8-1](#).

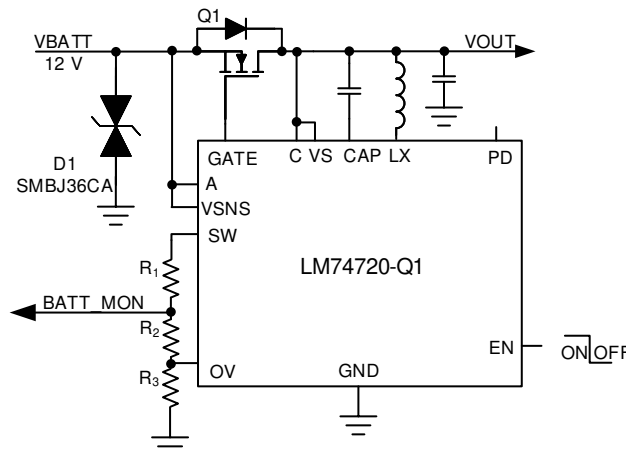

Figure 8-1. Configuring LM74720-Q1 for Ideal Diode Only

8.3.1.2 Load Disconnect Switch Control (PD)

PD pin provides a $50\text{-}\mu\text{A}$ drive and 88-mA peak pulldown strength for the load disconnect switch stage. Connect the Gate of the FET to PD pin. Place a 18-V Zener (D_z) across the FET gate and source.

For inrush current limiting, connect C_{dVdT} capacitor and R_1 as shown in [Figure 8-2](#).

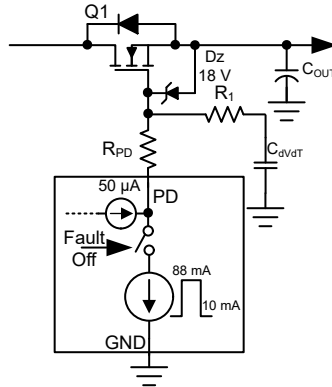

Figure 8-2. Inrush Current Limiting

The C_{dVdT} capacitor is required for slowing down the PD voltage ramp during power up for inrush current limiting. Use [Equation 1](#) to calculate C_{dVdT} capacitance value.

$$C_{dVdT} = \frac{I_{PD_DRV}}{I_{INRUSH}} \times C_{OUT} \quad (1)$$

where I_{PD_DRV} is 50 μ A (typical), I_{INRUSH} is the inrush current, and C_{OUT} is the output load capacitance. An extra resistor, R_1 , in series with the C_{dVdT} capacitor improves the turn-off time.

PD is pulled low during the following conditions:

- During an OV event with the OV pin voltage rising above the $V_{(OVR)}$ threshold
- When the EN pin is pulled low with $V_{(EN)}$ driven lower than $V_{(EN_IL)}$ level
- When the voltage at VS pin drops below the $V_{(VS_POR)}$ falling threshold

During these conditions, the FET Q1 turns OFF with its GATE connected to its SOURCE terminal through the external Zener (Dz).

The peak power dissipated in the LM74720-Q1 at the instance of PD pulldown can be calculated approximately using [Equation 2](#).

$$P_{PD_peak} = V_{OUT} \times I_{PD_SINK} \quad (2)$$

where

- I_{PDSINK_peak} is the peak sink current of 88 mA (typical)

In the system designs with input voltage above 48 V, TI recommends to place a resistor, R_{PD} , in series with the PD pin as shown in [Figure 8-2](#). The peak power dissipation during the pulldown events gets distributed in R_{PD} and the internal PD switch. A resistor value in the range of 270 Ω to 330 Ω can be selected to limit the device power dissipation within the safe limits. [Figure 6-12](#) shows the turn-OFF delay characteristics with various resistors.

8.3.2 Overvoltage Protection and Battery Voltage Sensing (VSNS, SW, OV)

Connect a resistor ladder as shown in [Figure 8-3](#) for overvoltage threshold programming.

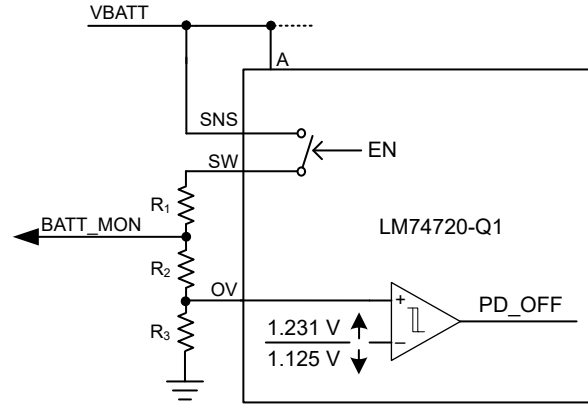

Figure 8-3. Programming Overvoltage Threshold and Battery Sensing

A disconnect switch is integrated between VSNS and SW pins. This switch is turned OFF when EN pin is pulled low. This action helps to reduce the leakage current through the resistor divider network during system shutdown state (IGN_OFF state).

8.3.3 Boost Regulator

The LM74720-Q1 integrates a boost converter to provide voltage necessary to drive the external N-channel MOSFETs for the ideal diode and the load disconnect stages. The boost converter uses hysteretic mode control scheme for the output voltage (V_{CAP-VS}) regulation along with the constant peak inductor current limit (I_{LX}). When the CAP-VS voltage is below its nominal value of typically 11.9 V, the low side switch of the boost is turned on and the inductor current rises with the slope of VS/L approximately. After the current hits the limit of I_{LX} , that is, 140 mA (typical), then the low side switch is turned off and the inductor current discharges to the output till it reaches zero. The low side switch is turned on again and the switching cycle repeats until the CAP-VS voltage has risen above the boost rising threshold of 13 V (typical). After this threshold level is reached, the boost converter switching is turned OFF to reduce the quiescent current.

For the boost converter to be enabled, the EN pin voltage must be above the specified input high threshold, $V_{(ENR)}$. The boost converter has a maximum output load capacity of 29-mA typical. If EN pin is pulled low, then the boost converter remains disabled.

8.4 Device Functional Mode (Shutdown Mode)

The LM74720-Q1 enters shutdown mode when the EN pin voltage is below the specified input low threshold, $V_{(EN_IL)}$. Both the gate drivers (GATE and PD) and the boost regulator are disabled in shutdown mode. During shutdown mode, the LM74720-Q1 enters low IQ operation with a total input quiescent consumption of 1.5 μ A (typical).

9 Application and Implementation

Note

Information in the following applications sections is not part of the TI component specification, and TI does not warrant its accuracy or completeness. TI's customers are responsible for determining suitability of components for their purposes, as well as validating and testing their design implementation to confirm system functionality.

9.1 Application Information

LM74720-Q1 controls two N-channel power MOSFETs with GATE used to control diode MOSFET to emulate an ideal diode and PD controlling second MOSFET for power path cut-off when disabled or during an overvoltage protection and provide inrush current limiting. IQ during operation (EN = High) is < 35 μ A and < 3.3 μ A during shutdown mode (EN = Low). LM74720-Q1 can be placed into low quiescent current mode using EN = low, where both GATE and PD are turned OFF.

9.2 Typical 12-V Reverse Battery Protection Application

A typical application circuit of LM74720-Q1 configured to provide reverse battery protection with overvoltage protection and inrush current limiting is shown in Figure 9-1.

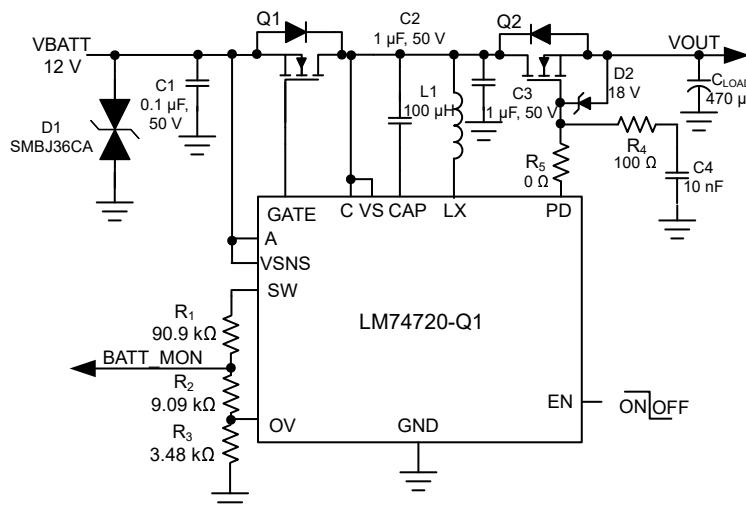

Figure 9-1. Typical Application Circuit – 12-V Reverse Battery Protection and Overvoltage Protection

9.2.1 Design Requirements for 12-V Battery Protection

The system design requirements are listed in Table 9-1.

Table 9-1. Design Parameters – 12-V Reverse Battery Protection and Overvoltage Protection

DESIGN PARAMETER	EXAMPLE VALUE
Operating input voltage range	12-V battery, 12-V nominal with 3.2-V cold crank and 35-V load dump
Output power	50 W
Output current range	4-A nominal, 5-A maximum
Input capacitance	0.1- μ F minimum
Output capacitance	0.1- μ F minimum, (optional 220 μ F for E-10 functional class A performance)
Overvoltage cut-off	37 V, output cut-off > 37 V
AC super imposed test	2-V peak-peak 30 kHz, extendable to 6-V peak-peak 30 kHz
Automotive transient immunity compliance	ISO 7637-2, ISO 16750-2 and LV124
Battery monitor ratio	8:1

9.2.2 Automotive Reverse Battery Protection

9.2.2.1 Input Transient Protection: ISO 7637-2 Pulse 1

ISO 7637-2 pulse 1 specifies negative transient immunity of electronic modules connected in parallel with an inductive load when the battery is disconnected. A typical pulse 1 specified in ISO 7637-2 starts with battery disconnection where supply voltage collapses to 0 V followed by -150 V 2 ms applied with a source impedance of $10\ \Omega$ at a slew rate of $1\ \mu\text{s}$ on the supply input. LM74720-Q1 blocks reverse current and prevents the output voltage from swinging negative, protecting the rest of the electronic circuits from damage due to negative transient voltage. MOSFET Q1 is quickly turned off within $0.5\ \mu\text{s}$ by fast reverse comparator of LM74720-Q1. A single bidirectional TVS is required at the input to clamp the negative transient pulse within the operating maximum voltage across cathode to anode of 85 V and does not violate the MOSFET Q1 drain-source breakdown voltage rating.

Figure 9-2 shows ISO 7637-2 pulse 1 performance of LM74720-Q1.

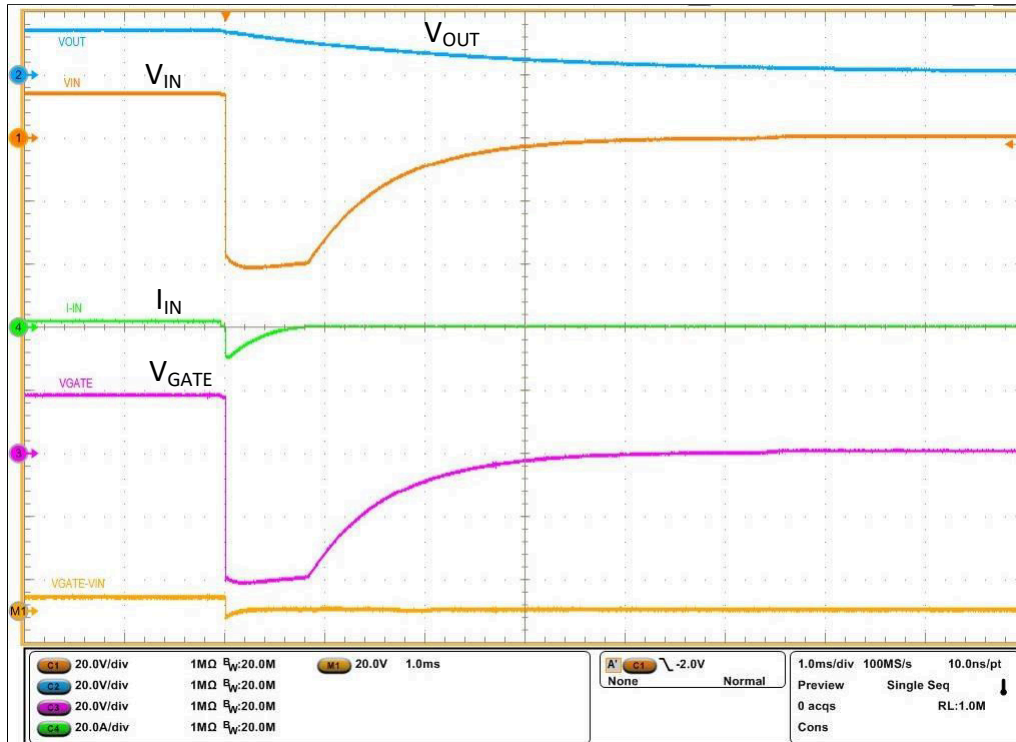

Figure 9-2. Performance During ISO 7637-2 Pulse 1 Test

9.2.2.2 AC Super Imposed Input Rectification: ISO 16750-2 and LV124 E-06

All electronic modules are tested for proper operation with superimposed AC ripple on the DC battery voltage. AC super imposed test specified in ISO 16750-2 and LV124 E-06 requires AC ripple of 2-V peak-peak on a 13.5-V DC battery voltage, swept from 15 Hz to 30 kHz. LM74720-Q1 rectifies the AC superimposed voltage by turning the MOSFET Q1 OFF quickly to cut off reverse current and turning the MOSFET Q1 ON quickly during forward conduction. Active rectification of 2-V peak-peak 5-kHz AC input by LM74720-Q1 is shown in Figure 9-3. Fast turn-OFF and quick turn-ON of the MOSFET reduces power dissipation in the MOSFET Q1 and active rectification reduces power dissipation in the output hold-up capacitor's ESR by half. Active rectification of 2-V peak-peak 30-kHz AC input is shown in Figure 9-4.

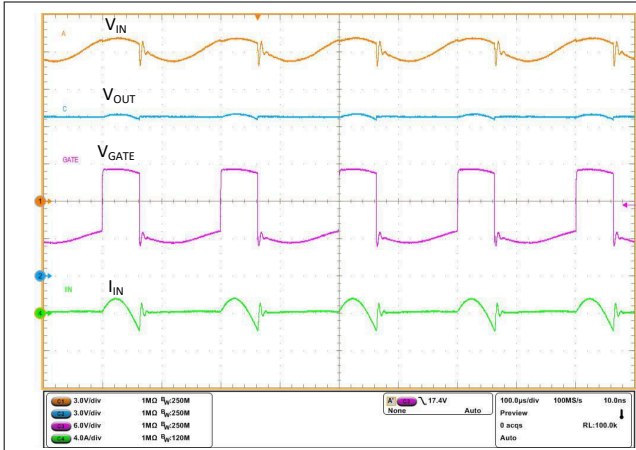

Figure 9-3. AC Super Imposed Test – 2-V Peak-Peak 5 kHz

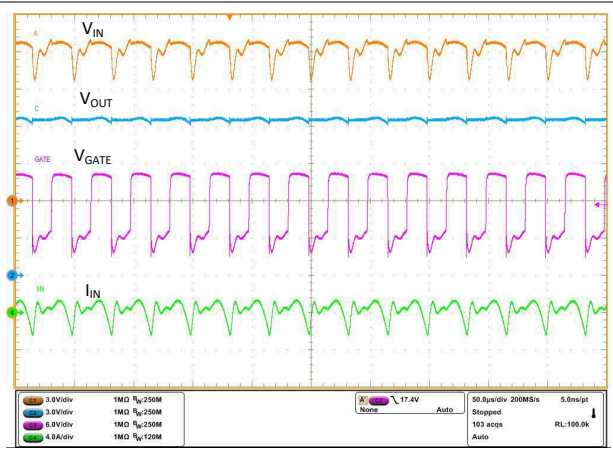

Figure 9-4. AC Super Imposed Test – 2-V Peak-Peak 30 kHz

9.2.2.3 Input Micro-Short Protection: LV124 E-10

E-10 test specified in LV124 standard checks for immunity of electronic modules to short interruptions in power supply input due to contact issues or relay bounce. During this test (case 2), micro-short is applied on the input for a duration as low as 10 μ s to several ms. For a functional pass status A, electronic modules are required to run uninterrupted during the E-10 test (case 2) with 100- μ s duration. When input micro-short is applied for 100 μ s, LM74720-Q1 quickly turns off MOSFET Q1 by shorting GATE to ANODE (source of MOSFET) within 0.5 μ s to prevent the output from discharging and the PD remains ON keeping MOSFET Q2 ON, enabling fast recovery after the input short is removed.

Figure 9-5 shows performance of LM74720-Q1 during E10 input power supply interruption test case 2. After the input short is removed, input voltage recovers and MOSFET Q1 is turned back ON within 200 μ s. Note that dual-gate drive topology allows MOSFET Q2 to remain ON during the test and helps in restoring the input power faster. Output voltage remains unperturbed during the entire duration, achieving functional status A.

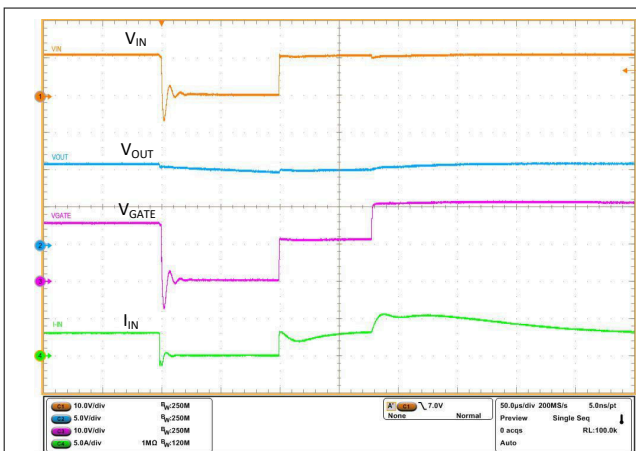

Figure 9-5. Input Micro-Short – LV124 E10 TC 2 100 μ s

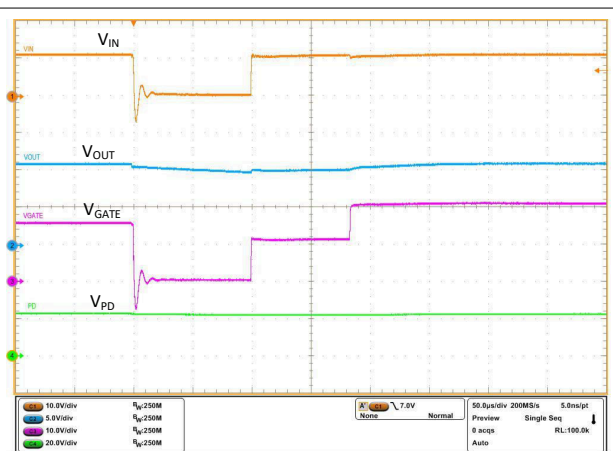

Figure 9-6. Input Micro-Short – LV124 E10 TC 2 100 μ s With PD

9.2.3 Detailed Design Procedure

9.2.3.1 Design Considerations

Table 9-1 summarizes the design parameters that must be known for designing an automotive reverse battery protection circuit with overvoltage cut-off. During power up, inrush current through MOSFET Q2 must be limited so that the MOSFET operates well within its SOA. Maximum load current, maximum ambient temperature, and thermal properties of the PCB determine the $R_{DS(ON)}$ of the MOSFET Q2 and maximum operating voltage determines the voltage rating of the MOSFET Q2. Selection of MOSFET Q2 is determined mainly by the maximum operating load current, maximum ambient temperature, maximum frequency of AC super imposed voltage ripple, and ISO 7637-2 pulse 1 requirements. Overvoltage threshold is decided based on the rating of downstream DC/DC converter or other components after the reverse battery protection circuit. A single bidirectional TVS or two back-back unidirectional TVS are required to clamp input transients to a safe operating level for the MOSFETs Q1, Q2, and LM74720-Q1.

9.2.3.2 Boost Converter Components (C2, C3, L1)

Place a minimum of a 1- μ F capacitor across drain of the FET to GND (C2) and across CAP pin of LM74720-Q1 to drain of the FET (C3). Use a 100- μ H inductor (L1) with saturation current rating > 175 mA. Example: XPL2010-104ML from coil craft.

9.2.3.3 Input and Output Capacitance

TI recommends a minimum input capacitance C1 of 0.1 μ F and output capacitance C_{OUT} of 0.1 μ F.

9.2.3.4 Hold-Up Capacitance

Usually bulk capacitors are placed on the output due to various reasons such as uninterrupted operation during power interruption or micro-short at the input, hold-up requirements for doing a memory dump before turning of the module and filtering requirements as well. This design considers minimum bulk capacitors requirements for meeting functional status "A" during LV124 E10 test case 2 100- μ s input interruption. To achieve functional pass status A, acceptable voltage droop in the output of LM74720-Q1 is based on the UVLO settings of downstream DC/DC converters. For this design, a 1-V drop in output voltage for 100 μ s is considered and the minimum hold-up capacitance required is calculated by

$$C_{HOLD_UP_MIN} = \frac{I_{LOAD_MAX}}{dV_{OUT}} \times 100 \mu s \quad (3)$$

Hold-up capacitance required for 1-V drop in 100 μ s is 470 μ F.

9.2.3.5 Overvoltage Protection and Battery Monitor

Resistors R_1 , R_2 and R_3 connected in series are used to program the overvoltage threshold and battery monitor ratio. The resistor values required for setting the overvoltage threshold V_{OV} to 37 V and battery monitor ratio $V_{BATT_MON} : V_{BATT}$ to 1:8 are calculated by solving Equation 3 and Equation 4.

$$V_{OVR} = \frac{R_3}{R_1 + R_2 + R_3} \times V_{OV} \quad (4)$$

$$V_{BAT_MON} = \frac{R_2 + R_3}{R_1 + R_2 + R_3} \times V_{BATT} \quad (5)$$

For minimizing the input current drawn from the battery through resistors R_1 , R_2 and R_3 , TI recommends to use higher value of resistance. Using high value resistors adds error in the calculations because the current through the resistors at higher value become comparable to the leakage current into the OV pin. Maximum leakage current into the OV pin is 1 μ A and choosing $(R_1 + R_2 + R_3) < 120$ k Ω ensures current through resistors is 100 times greater than leakage through OV pin.

Based on the device electrical characteristics, V_{OVR} is 1.23 V and battery monitor ratio (V_{BATT_MON} / V_{BATT}) is designed for a ratio of 1:8. To limit $(R_1 + R_2 + R_3) < 120 \text{ k}\Omega$, select $(R_1 + R_2) = 100 \text{ k}\Omega$. Solving Equation 3 gives $R_3 = 3.45 \text{ k}\Omega$. Solving Equation 4 for R_2 using $(R_1 + R_2) = 100 \text{ k}\Omega$ and $R_3 = 3.45 \text{ k}\Omega$, gives $R_2 = 9.48 \text{ k}\Omega$ and $R_1 = 90.52 \text{ k}\Omega$.

Standard 1% resistor values closest to the calculated resistor values are $R_1 = 90.9 \text{ k}\Omega$, $R_2 = 9.09 \text{ k}\Omega$, and $R_3 = 3.48 \text{ k}\Omega$.

9.2.3.6 MOSFET Selection: Blocking MOSFET Q1

For selecting the blocking MOSFET Q1, important electrical parameters are the maximum continuous drain current I_D , the maximum drain-to-source voltage $V_{DS(MAX)}$, the maximum drain-to-source voltage $V_{GS(MAX)}$, the maximum source current through body diode and the drain-to-source ON resistance $R_{DS(ON)}$.

The maximum continuous drain current, I_D , rating must exceed the maximum continuous load current.

The maximum drain-to-source voltage, $V_{DS(MAX)}$, must be high enough to withstand the highest differential voltage seen in the application. This action includes all the automotive transient events and any anticipated fault conditions. TI recommends to use MOSFETs with V_{DS} voltage rating of 60 V along with a single bidirectional TVS or a V_{DS} rating 40-V maximum rating along with two unidirectional TVS connected back-to-back at the input.

The maximum V_{GS} LM74720-Q1 can drive is 14 V, so a MOSFET with 15-V minimum V_{GS} rating must be selected. If a MOSFET with $< 15\text{-V}$ V_{GS} rating is selected, a zener diode can be used to clamp V_{GS} to safe level, but this results in increased I_Q current.

To reduce the MOSFET conduction losses, lowest possible $R_{DS(ON)}$ is preferred, but selecting a MOSFET based on low $R_{DS(ON)}$ cannot be beneficial always. Higher $R_{DS(ON)}$ provides increased voltage information to LM74720-Q1's reverse comparator at a lower reverse current. Reverse current detection is better with increased $R_{DS(ON)}$. Choosing a MOSFET with $< 50\text{-mV}$ forward voltage drop at maximum current is a good starting point. Based on the design requirements, BUK7Y4R8-60E MOSFET is selected

9.2.3.7 MOSFET Selection: Load Disconnect MOSFET Q2

The V_{DS} rating of the MOSFET Q2 must be sufficient to handle the maximum system voltage along with the input transient voltage. For this 12-V design, transient overvoltage events are during suppressed load dump 35 V 400 ms and ISO 7637-2 pulse 2 A 50 V for 50 μs . Furthermore, ISO 7637-2 Pulse 3B is a very fast repetitive pulse of 100 V 100 ns that is usually absorbed by the input and output ceramic capacitors and the maximum voltage on the 12-V battery can be limited to $< 40 \text{ V}$ the minimum recommended input capacitance of 0.1 μF . The 50-V SO 7637-2 Pulse 2 A can also be absorbed by input and output capacitors and its amplitude can be reduced to 40-V peak by placing sufficient amount of capacitance at input and output. Choose a MOSFET with $\geq 40\text{-V}$ V_{DS} rating.

The V_{GS} rating of the MOSFET Q2 must be higher than that maximum boost drive output of 15.5 V. FET with V_{GS} absolute maximum rating of $\pm 20 \text{ V}$ is selected.

Inrush current through the MOSFET during input hot-plug into the 12-V battery is determined by output capacitance. External capacitor on PD, C_{DVRT} , is used to limit the inrush current during input hot-plug or startup. The value of inrush current determined by Equation 1 must be selected to ensure that the MOSFET Q2 is operating well within its safe operating area (SOA). To limit inrush current to 1.8-A, value of C_{DVRT} is 10.43 nF, closest standard value of 10.0 nF is chosen.

Duration of inrush current is calculated by:

$$dT_{INRUSH} = \frac{12}{I_{INRUSH}} \times C_{OUT} \quad (6)$$

Calculated inrush current duration is 3.13 ms with 1.8-A inrush current.

MOSFET BUK7Y4R8-60E having 60-V V_{DS} and ± 20 -V V_{GS} rating is selected for Q2. Power dissipation during inrush is well within the MOSFET's safe operating area (SOA).

9.2.3.8 TVS Selection

TI recommends a 600-W SMBJ TVS such as SMBJ33CA for input transient clamping and protection. For detailed explanation on TVS selection for 12-V battery systems, refer to [TVS Selection for 12-V Battery Systems](#).

9.2.4 Application Curves

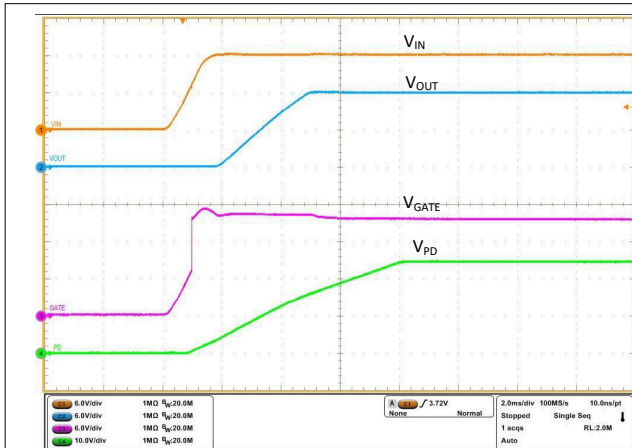

Figure 9-7. Start-up 12 V with EN Pulled to VIN

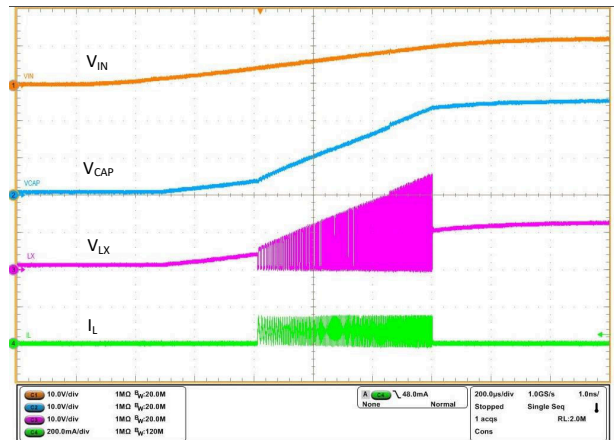

Figure 9-8. Start-up 12 V Showing Boost Output (VCAP) and Switching (VLX)

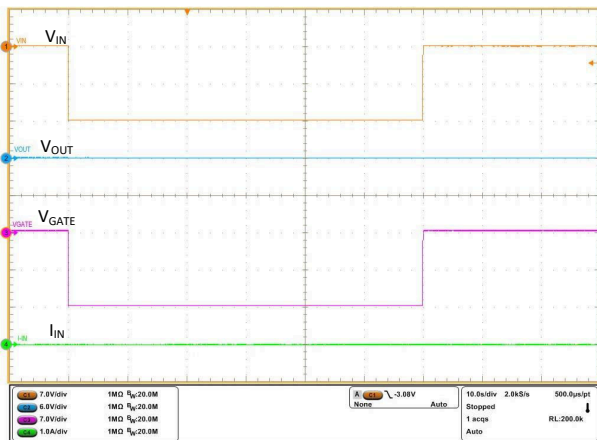

Figure 9-9. Reverse Input Voltage -14 V for 60 s

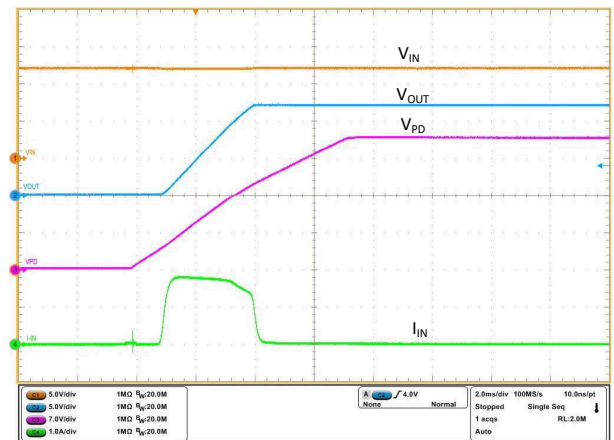

Figure 9-10. Inrush Current with No Load at Output

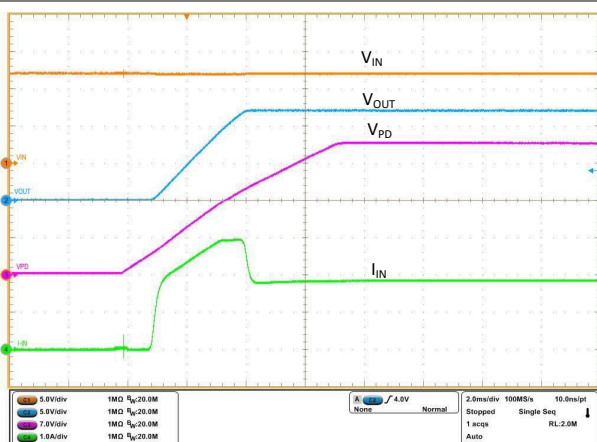

Figure 9-11. Inrush Current with 60-Ω Load

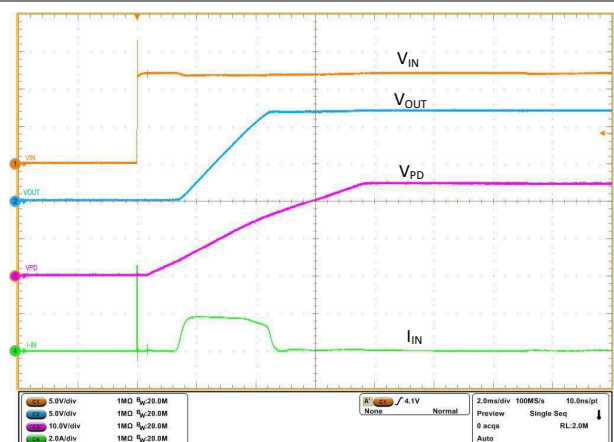

Figure 9-12. Hot-Plug into 12 V

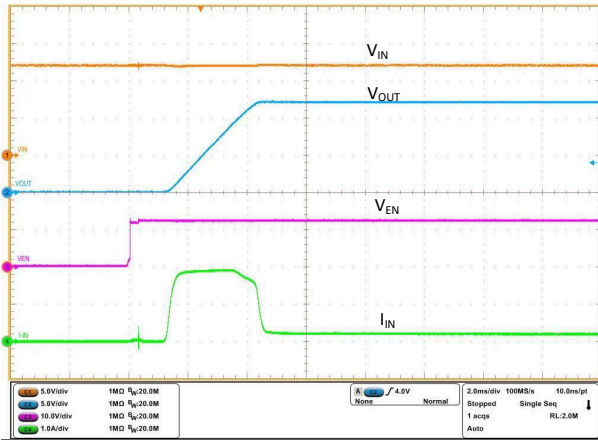

Figure 9-13. Output Turn-on with Enable

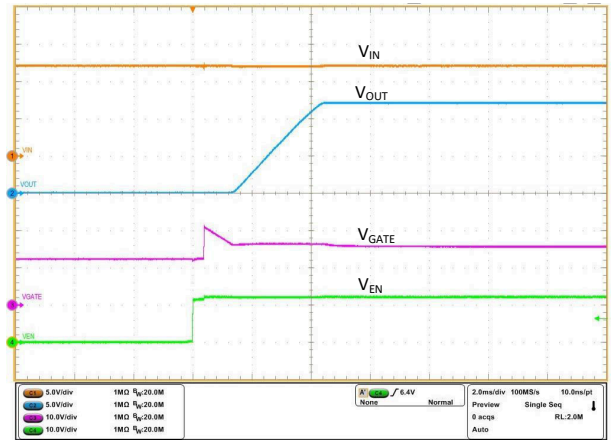

Figure 9-14. GATE Turn-on with Enable

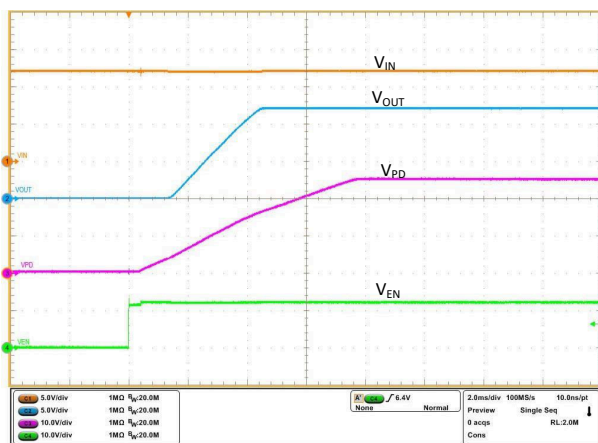

Figure 9-15. PD Turn-on with Enable

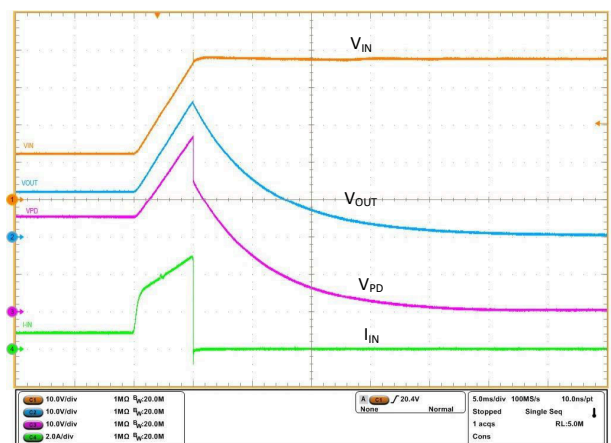

Figure 9-16. Overvoltage Protection

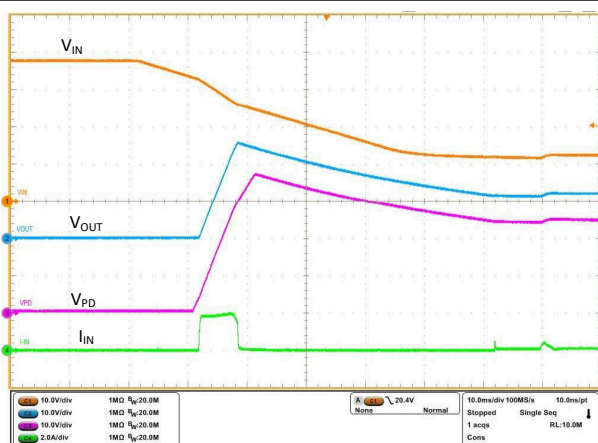

Figure 9-17. Overvoltage Recovery

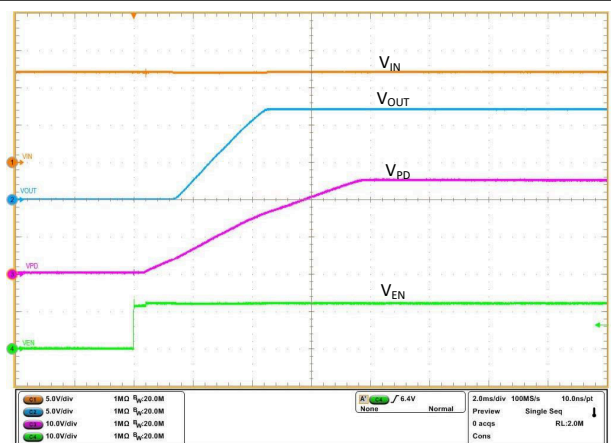
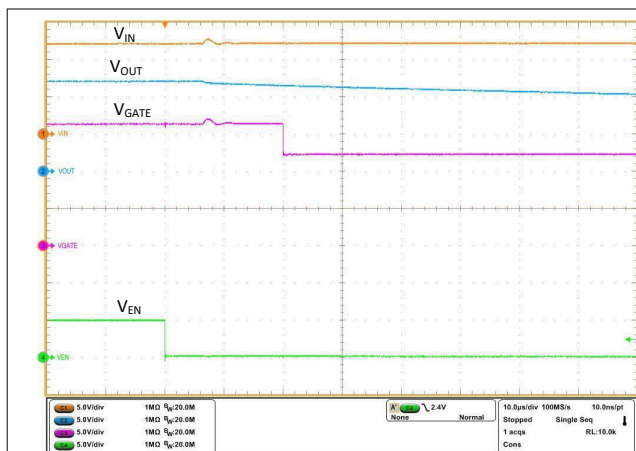
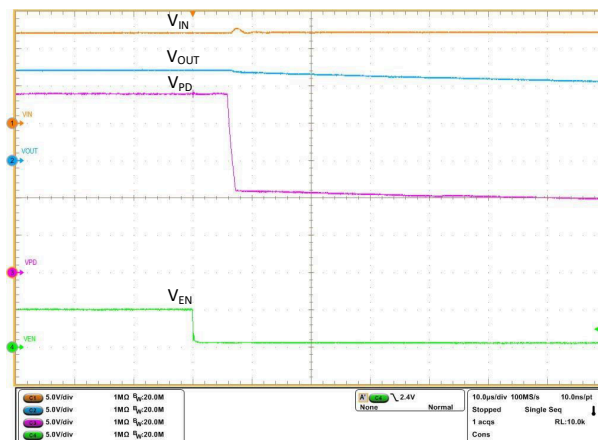

Figure 9-18. Turn-on Delay – PD

Figure 9-19. Turn-off Delay – GATE

Figure 9-20. Turn-off Delay – PD

9.3 Do's and Don'ts

- Leave the exposed pad (RTN) of the IC floating. Do not connect the exposed pad to the GND plane. Connecting RTN to GND disables the reverse polarity protection feature.
- Connect a limiting resistor R_{PD} in series with the PD pin in the system application designs with input voltage above 48 V. This resistor value can be chosen in the range of 270 Ω to 330 Ω .

10 Power Supply Recommendations

10.1 Transient Protection

When the external MOSFETs turn OFF during the conditions, such as overvoltage cut-off, reverse current blocking, EN causing an interruption of the current flow, the input line inductance generates a positive voltage spike on the input and output inductance generates a negative voltage spike on the output. The peak amplitude of voltage spikes (transients) depends on the value of inductance in series to the input or output of the device. These transients can exceed the *Absolute Maximum Ratings* of the device if steps are not taken to address the issue.

Typical methods for addressing transients include:

- Minimizing lead length and inductance into and out of the device
- Using large PCB GND plane
- Using a Schottky diode across the output and GND to absorb negative spikes
- Using a low value ceramic capacitor ($C_{(IN)}$) to approximately 0.1 μF) to absorb the energy and dampen the transients.

The approximate value of input capacitance can be estimated with [Equation 7](#).

$$V_{\text{spike(Absolute)}} = V_{(IN)} + I_{(Load)} \times \sqrt{\frac{L_{(IN)}}{C_{(IN)}}} \quad (7)$$

where

- $V_{(IN)}$ is the nominal supply voltage
- $I_{(LOAD)}$ is the load current
- $L_{(IN)}$ equals the effective inductance seen looking into the source
- $C_{(IN)}$ is the capacitance present at the input

Some applications can require additional Transient Voltage Suppressor (TVS) to prevent transients from exceeding the *Absolute Maximum Ratings* of the device. These transients can occur during EMC testing such as automotive ISO7637 pulses.

The circuit implementation with optional protection components (a ceramic capacitor, TVS, and Schottky diode) is shown in [Figure 10-1](#).

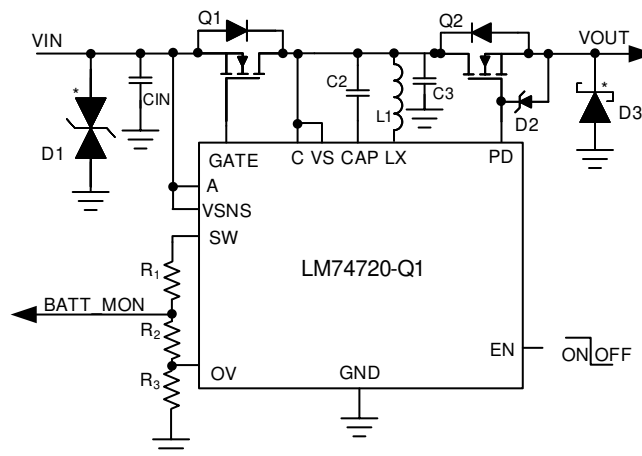

* Optional components needed for suppression of transients

Figure 10-1. Circuit Implementation With Optional Protection Components for LM74720-Q1

10.2 TVS Selection for 12-V Battery Systems

In selecting the TVS, important specifications are breakdown voltage and clamping voltage. The breakdown voltage of the TVS+ must be higher than 24-V jump start voltage and 35-V suppressed load dump voltage and less than the maximum ratings of LM74720-Q1 (65 V). The breakdown voltage of TVS– must be beyond than maximum reverse battery voltage –16 V, so that the TVS– is not damaged due to long time exposure to reverse connected battery.

Clamping voltage is the voltage the TVS diode clamps in high current pulse situations and this voltage is much higher than the breakdown voltage. In the case of an ISO 7637-2 pulse 1, the input voltage goes up to –150 V with a generator impedance of 10 Ω . This action translates to 15 A flowing through the TVS–, and the voltage across the TVS is close to its clamping voltage.

The next criterion is that the absolute maximum rating of cathode to anode voltage of the LM74720-Q1 (85 V) and the maximum V_{DS} rating MOSFET are not exceeded. In the design example, 60-V rated MOSFET is chosen and maximum limit on the cathode to anode voltage is 60 V.

During ISO 7637-2 pulse 1, the anode of LM74720-Q1 is pulled down by the ISO pulse, clamped by TVS– and the MOSFET Q1 is turned off quickly to prevent reverse current from discharging the bulk output capacitors. When the MOSFET turns off, the cathode to anode voltage seen is equal to (TVS Clamping voltage + Output capacitor voltage). If the maximum voltage on output capacitor is 16 V (maximum battery voltage), then the clamping voltage of the TVS– must not exceed, $(60\text{ V} - 16)\text{ V} = -44\text{ V}$.

The SMBJ33CA TVS diode can be used for 12-V battery protection application. The breakdown voltage of 36.7 V meets the jump start, load dump requirements on the positive side and 16-V reverse battery connection on the negative side. During ISO 7637-2 pulse 1 test, the SMBJ33CA clamps at –44 V with 12 A of peak surge current as shown in and it meets the clamping voltage $\leq 44\text{ V}$.

SMBJ series of TVS' are rated up to 600-W peak pulse power levels and are sufficient for ISO 7637-2 pulses.

10.3 TVS Selection for 24-V Battery Systems

For 24-V battery protection application, the TVS and MOSFET in [Figure 9-1](#) must be changed to suit 24-V battery requirements.

The breakdown voltage of the TVS+ must be higher than 48-V jump start voltage, less than the absolute maximum ratings of anode and enable pin of LM74720-Q1 (70 V) and must withstand 65-V suppressed load dump. The breakdown voltage of TVS– must be lower than maximum reverse battery voltage –32 V, so that the TVS– is not damaged due to long time exposure to reverse connected battery.

During ISO 7637-2 pulse 1, the input voltage goes up to –600 V with a generator impedance of 50 Ω . This translates to 12 A flowing through the TVS–. The clamping voltage of the TVS– cannot be same as that of 12-V battery protection circuit. Because during the ISO 7637-2 pulse, the Anode to Cathode voltage seen is equal to (– TVS Clamping voltage + Output capacitor voltage). For 24-V battery application, the maximum battery voltage is 32 V, then the clamping voltage of the TVS– must not exceed, $85\text{ V} - 32\text{ V} = 53\text{ V}$.

Single bidirectional TVS cannot be used for 24-V battery protection because breakdown voltage for TVS+ $\geq 65\text{ V}$, maximum clamping voltage is $\leq 53\text{ V}$ and the clamping voltage cannot be less than the breakdown voltage. Two un-directional TVS connected back-to-back must be used at the input. For positive side TVS+, TI recommends SMBJ58A with the breakdown voltage of 64.4 V (minimum), 67.8 (typical). For the negative side TVS–, TI recommends SMBJ28A with breakdown voltage close to 32 V (to withstand maximum reverse battery voltage –32 V) and maximum clamping voltage of 42.1 V.

For 24-V battery protection, TI recommends a 75-V rated MOSFET to be used along with SMBJ28A and SMBJ58A connected back-to-back at the input.

11 Layout

11.1 Layout Guidelines

- For the ideal diode stage, connect A, GATE and C pins of LM74720-Q1 close to the MOSFET's SOURCE, GATE and DRAIN pins.
- The high current path of for this solution is through the MOSFET; therefore, it is important to use thick and short traces for source and drain of the MOSFET to minimize resistive losses.
- The GATE pin of the LM74720-Q1 must be connected to the MOSFET GATE with short trace.
- Boost converter switching currents flow into LX, CAP, GND pins and C3 (across DRAIN of the FET to GND). The loops formed by capacitor across CAP pin and DRAIN of the FET and C3 to GND must be minimized by placing these capacitors as close as possible.
- Place transient suppression components like input TVS and output Schottky close to LM74720-Q1.

11.2 Layout Example

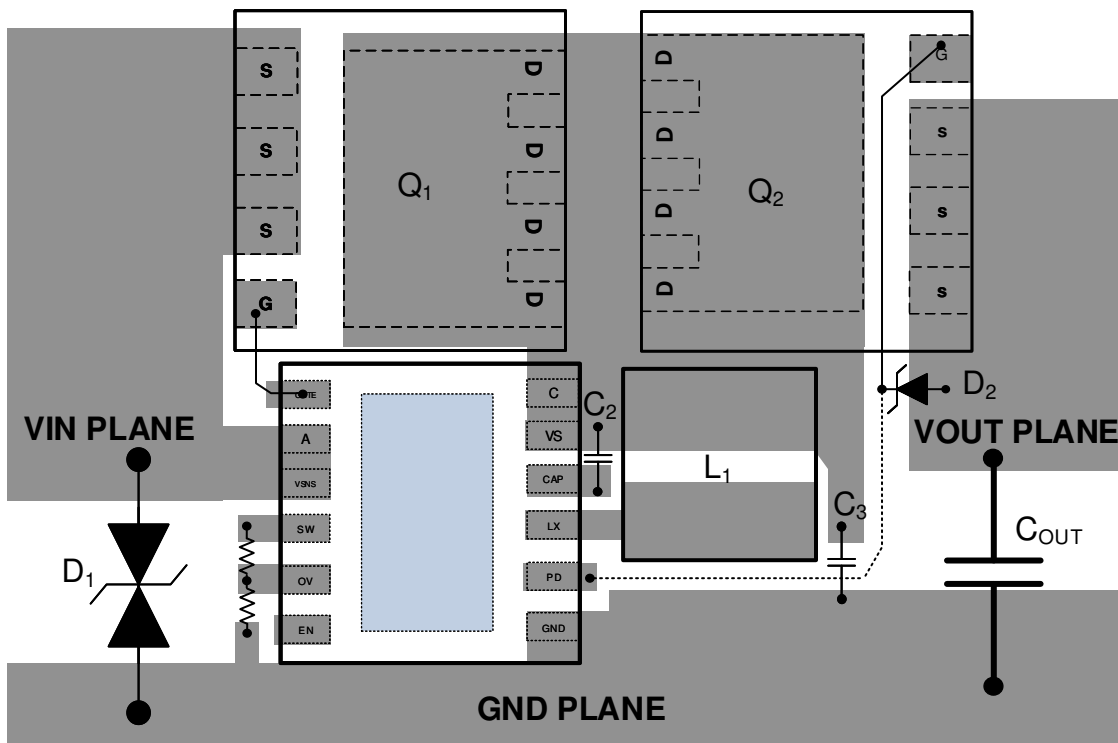

Figure 11-1. LM74720-Q1 Layout Example

12 Device and Documentation Support

12.1 Third-Party Products Disclaimer

TI'S PUBLICATION OF INFORMATION REGARDING THIRD-PARTY PRODUCTS OR SERVICES DOES NOT CONSTITUTE AN ENDORSEMENT REGARDING THE SUITABILITY OF SUCH PRODUCTS OR SERVICES OR A WARRANTY, REPRESENTATION OR ENDORSEMENT OF SUCH PRODUCTS OR SERVICES, EITHER ALONE OR IN COMBINATION WITH ANY TI PRODUCT OR SERVICE.

12.2 Receiving Notification of Documentation Updates

To receive notification of documentation updates, navigate to the device product folder on ti.com. Click on *Subscribe to updates* to register and receive a weekly digest of any product information that has changed. For change details, review the revision history included in any revised document.

12.3 Support Resources

TI E2E™ [support forums](#) are an engineer's go-to source for fast, verified answers and design help — straight from the experts. Search existing answers or ask your own question to get the quick design help you need.

Linked content is provided "AS IS" by the respective contributors. They do not constitute TI specifications and do not necessarily reflect TI's views; see TI's [Terms of Use](#).

12.4 Trademarks

TI E2E™ is a trademark of Texas Instruments.

All trademarks are the property of their respective owners.

12.5 Electrostatic Discharge Caution



This integrated circuit can be damaged by ESD. Texas Instruments recommends that all integrated circuits be handled with appropriate precautions. Failure to observe proper handling and installation procedures can cause damage.

ESD damage can range from subtle performance degradation to complete device failure. Precision integrated circuits may be more susceptible to damage because very small parametric changes could cause the device not to meet its published specifications.

12.6 Glossary

[TI Glossary](#) This glossary lists and explains terms, acronyms, and definitions.

13 Mechanical, Packaging, and Orderable Information

The following pages include mechanical, packaging, and orderable information. This information is the most current data available for the designated devices. This data is subject to change without notice and revision of this document. For browser-based versions of this data sheet, refer to the left-hand navigation.

PACKAGING INFORMATION

Orderable Device	Status (1)	Package Type	Package Drawing	Pins	Package Qty	Eco Plan (2)	Lead finish/ Ball material (6)	MSL Peak Temp (3)	Op Temp (°C)	Device Marking (4/5)	Samples
LM74720QDRRRQ1	ACTIVE	WSON	DRR	12	3000	RoHS & Green	NIPDAU	Level-2-260C-1 YEAR	-40 to 125	L74720	Samples

(1) The marketing status values are defined as follows:

ACTIVE: Product device recommended for new designs.

LIFEBUY: TI has announced that the device will be discontinued, and a lifetime-buy period is in effect.

NRND: Not recommended for new designs. Device is in production to support existing customers, but TI does not recommend using this part in a new design.

PREVIEW: Device has been announced but is not in production. Samples may or may not be available.

OBSOLETE: TI has discontinued the production of the device.

(2) **RoHS:** TI defines "RoHS" to mean semiconductor products that are compliant with the current EU RoHS requirements for all 10 RoHS substances, including the requirement that RoHS substance do not exceed 0.1% by weight in homogeneous materials. Where designed to be soldered at high temperatures, "RoHS" products are suitable for use in specified lead-free processes. TI may reference these types of products as "Pb-Free".

RoHS Exempt: TI defines "RoHS Exempt" to mean products that contain lead but are compliant with EU RoHS pursuant to a specific EU RoHS exemption.

Green: TI defines "Green" to mean the content of Chlorine (Cl) and Bromine (Br) based flame retardants meet JS709B low halogen requirements of <=1000ppm threshold. Antimony trioxide based flame retardants must also meet the <=1000ppm threshold requirement.

(3) MSL, Peak Temp. - The Moisture Sensitivity Level rating according to the JEDEC industry standard classifications, and peak solder temperature.

(4) There may be additional marking, which relates to the logo, the lot trace code information, or the environmental category on the device.

(5) Multiple Device Markings will be inside parentheses. Only one Device Marking contained in parentheses and separated by a "-" will appear on a device. If a line is indented then it is a continuation of the previous line and the two combined represent the entire Device Marking for that device.

(6) Lead finish/Ball material - Orderable Devices may have multiple material finish options. Finish options are separated by a vertical ruled line. Lead finish/Ball material values may wrap to two lines if the finish value exceeds the maximum column width.

Important Information and Disclaimer:The information provided on this page represents TI's knowledge and belief as of the date that it is provided. TI bases its knowledge and belief on information provided by third parties, and makes no representation or warranty as to the accuracy of such information. Efforts are underway to better integrate information from third parties. TI has taken and continues to take reasonable steps to provide representative and accurate information but may not have conducted destructive testing or chemical analysis on incoming materials and chemicals. TI and TI suppliers consider certain information to be proprietary, and thus CAS numbers and other limited information may not be available for release.

In no event shall TI's liability arising out of such information exceed the total purchase price of the TI part(s) at issue in this document sold by TI to Customer on an annual basis.

TAPE AND REEL INFORMATION

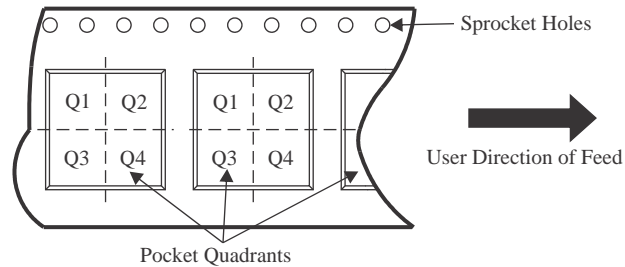
QUADRANT ASSIGNMENTS FOR PIN 1 ORIENTATION IN TAPE

*All dimensions are nominal

Device	Package Type	Package Drawing	Pins	SPQ	Reel Diameter (mm)	Reel Width W1 (mm)	A0 (mm)	B0 (mm)	K0 (mm)	P1 (mm)	W (mm)	Pin1 Quadrant
LM74720QDRRRQ1	WSO	DRR	12	3000	330.0	12.4	3.3	3.3	1.1	8.0	12.0	Q2

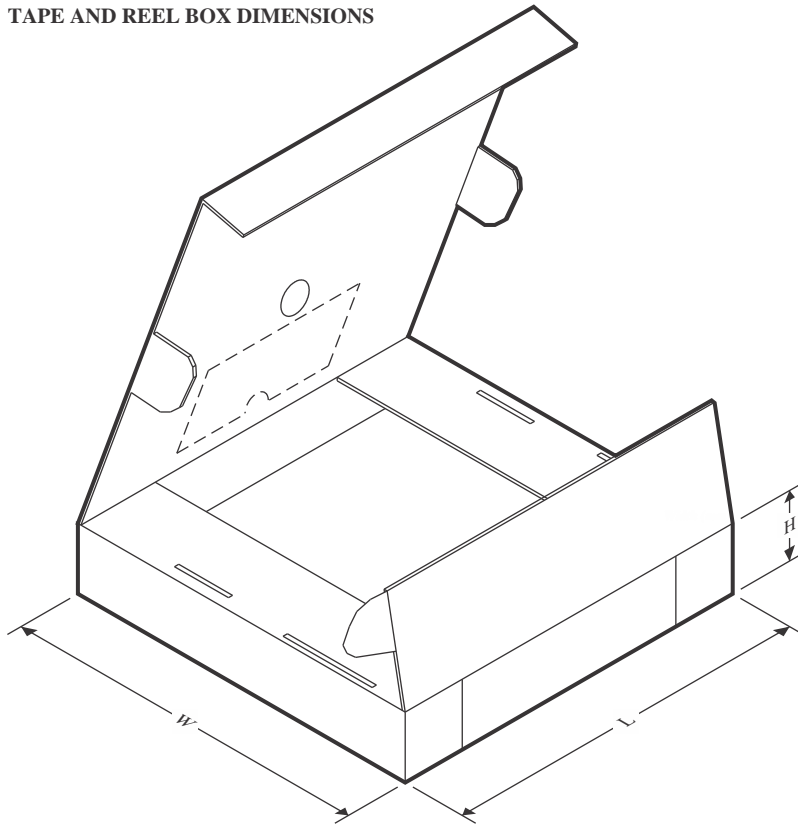
TAPE AND REEL BOX DIMENSIONS

*All dimensions are nominal

Device	Package Type	Package Drawing	Pins	SPQ	Length (mm)	Width (mm)	Height (mm)
LM74720QDRRRQ1	WSON	DRR	12	3000	367.0	367.0	35.0

GENERIC PACKAGE VIEW

DRR 12

WSON - 0.8 mm max height

3 x 3, 0.5 mm pitch

PLASTIC SMALL OUTLINE - NO LEAD

This image is a representation of the package family, actual package may vary.
Refer to the product data sheet for package details.

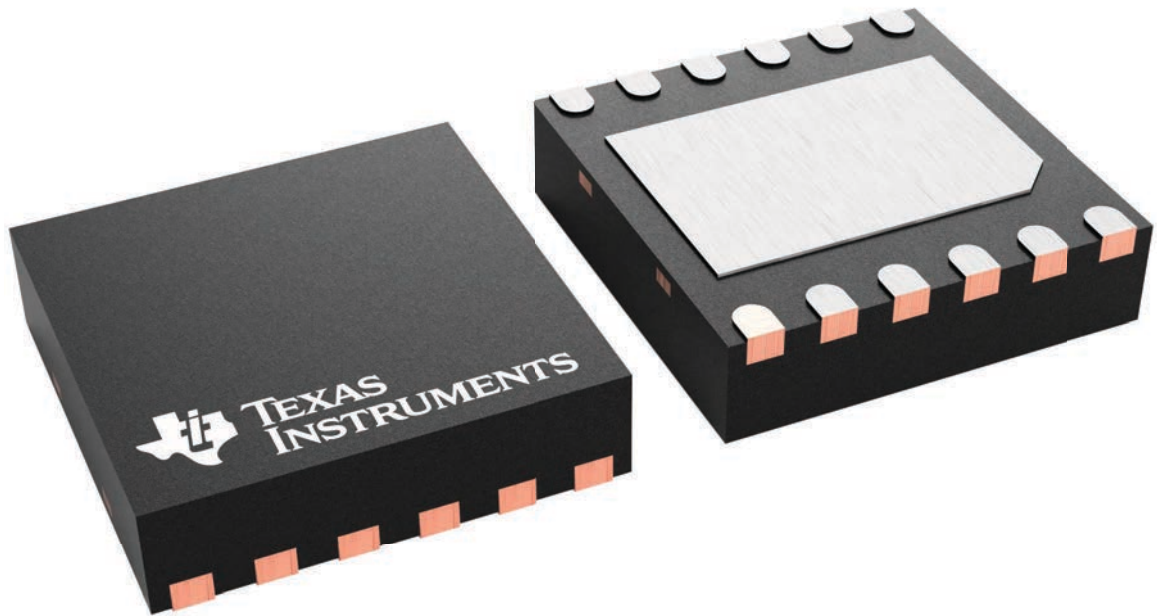

4223490/B

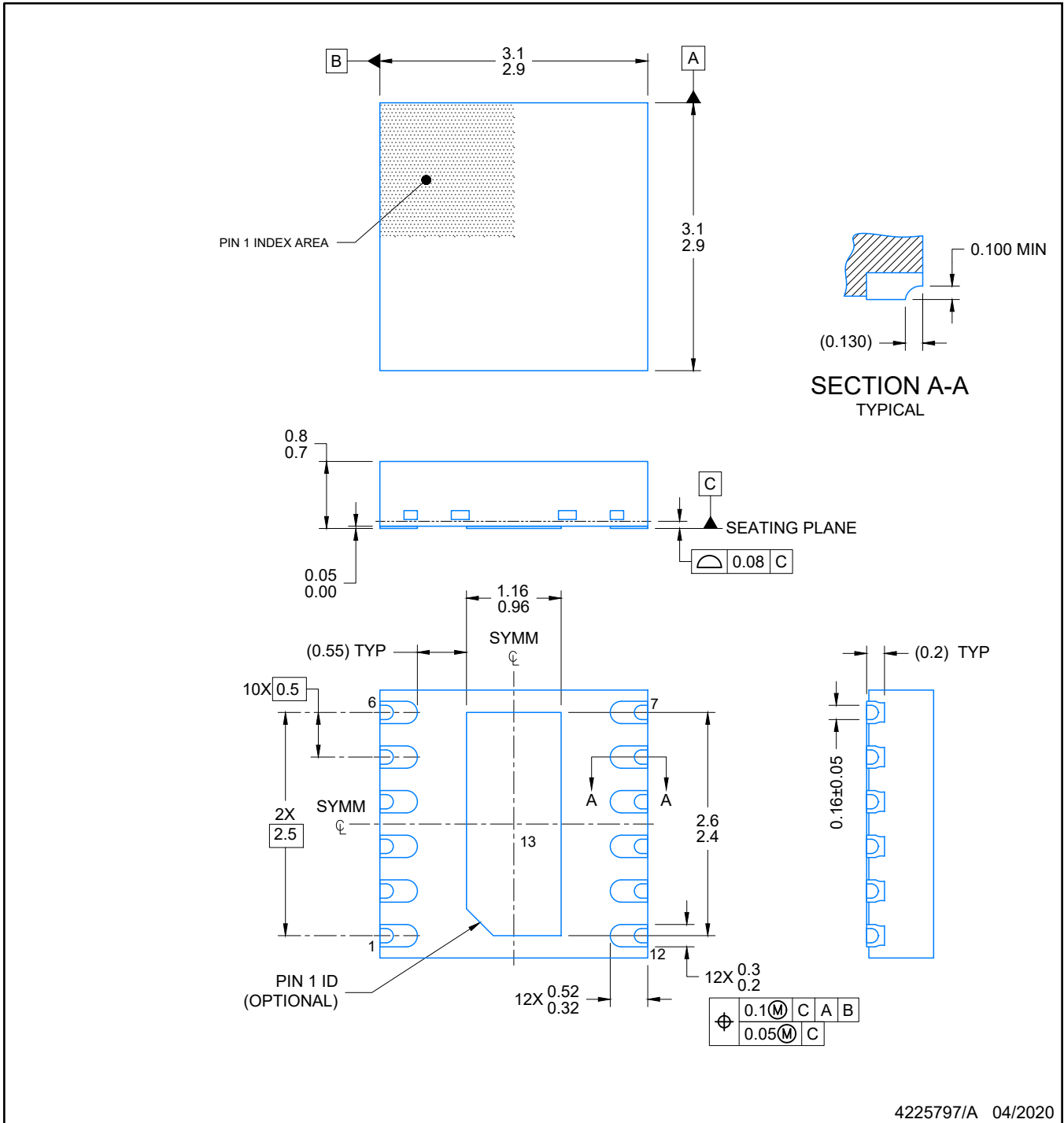

NOTES:

1. All linear dimensions are in millimeters. Any dimensions in parenthesis are for reference only. Dimensioning and tolerancing per ASME Y14.5M.
2. This drawing is subject to change without notice.
3. The package thermal pad must be soldered to the printed circuit board for optimal thermal and mechanical performance.

EXAMPLE BOARD LAYOUT

WSON - 0.8 mm max height

DRR0012F

PLASTIC QUAD FLAT PACK- NO LEAD

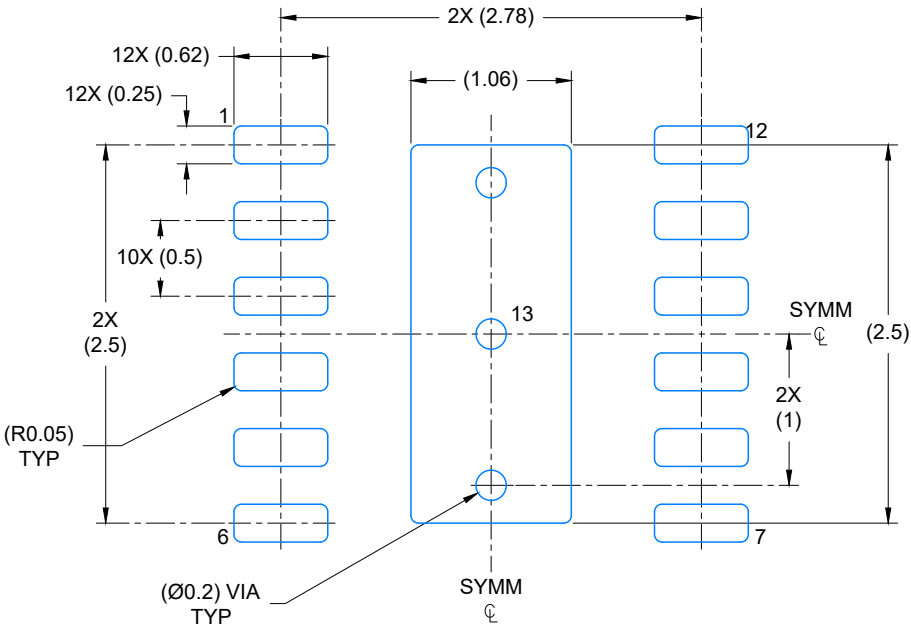

LAND PATTERN EXAMPLE
EXPOSED METAL SHOWN
SCALE: 20X

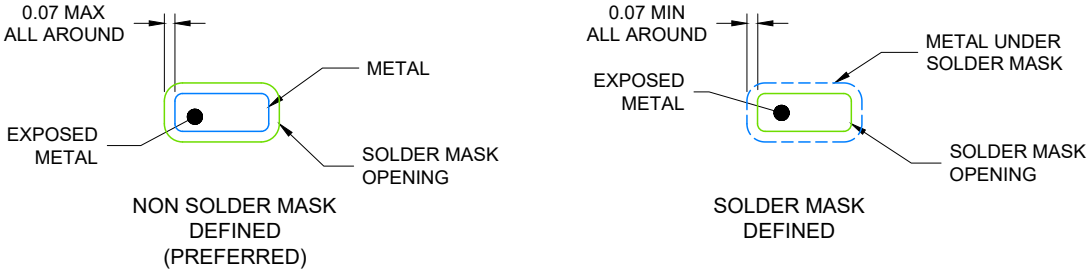

SOLDER MASK DETAILS

4225797/A 04/2020

NOTES: (continued)

4. This package is designed to be soldered to a thermal pad on the board. For more information, see Texas Instruments literature number SLUA271 (www.ti.com/lit/sluea271).
5. Vias are optional depending on application, refer to device data sheet. If any vias are implemented, refer to their locations shown on this view. It is recommended that vias under paste be filled, plugged or tented.

EXAMPLE STENCIL DESIGN

DRR0012F

WSON - 0.8 mm max height

PLASTIC QUAD FLAT PACK- NO LEAD

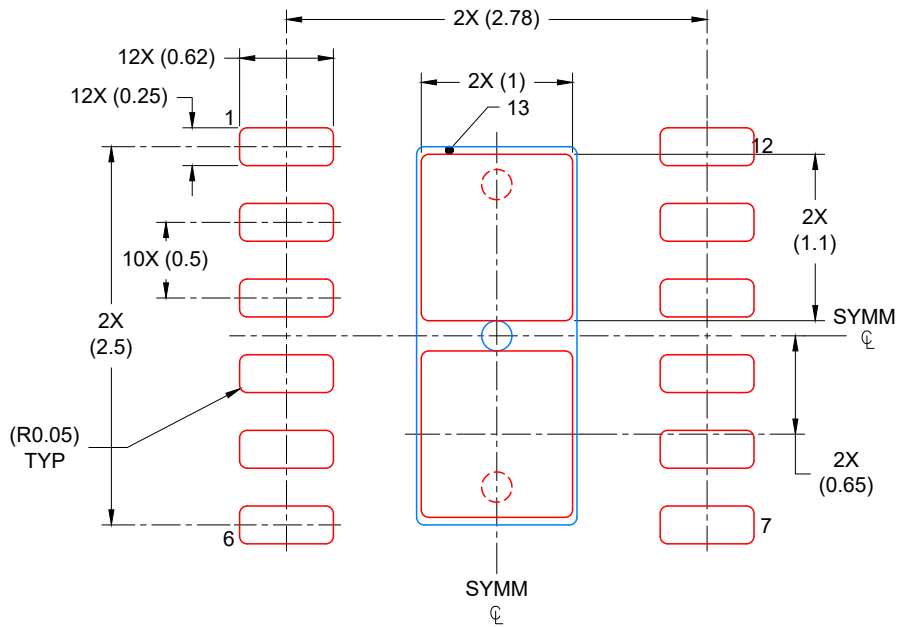

SOLDER PASTE EXAMPLE
BASED ON 0.125 mm THICK STENCIL

EXPOSED PAD
83% PRINTED COVERAGE BY AREA
SCALE: 20X

4225797/A 04/2020

NOTES: (continued)

6. Laser cutting apertures with trapezoidal walls and rounded corners may offer better paste release. IPC-7525 may have alternate design recommendations.

IMPORTANT NOTICE AND DISCLAIMER

TI PROVIDES TECHNICAL AND RELIABILITY DATA (INCLUDING DATA SHEETS), DESIGN RESOURCES (INCLUDING REFERENCE DESIGNS), APPLICATION OR OTHER DESIGN ADVICE, WEB TOOLS, SAFETY INFORMATION, AND OTHER RESOURCES "AS IS" AND WITH ALL FAULTS, AND DISCLAIMS ALL WARRANTIES, EXPRESS AND IMPLIED, INCLUDING WITHOUT LIMITATION ANY IMPLIED WARRANTIES OF MERCHANTABILITY, FITNESS FOR A PARTICULAR PURPOSE OR NON-INFRINGEMENT OF THIRD PARTY INTELLECTUAL PROPERTY RIGHTS.

These resources are intended for skilled developers designing with TI products. You are solely responsible for (1) selecting the appropriate TI products for your application, (2) designing, validating and testing your application, and (3) ensuring your application meets applicable standards, and any other safety, security, regulatory or other requirements.

These resources are subject to change without notice. TI grants you permission to use these resources only for development of an application that uses the TI products described in the resource. Other reproduction and display of these resources is prohibited. No license is granted to any other TI intellectual property right or to any third party intellectual property right. TI disclaims responsibility for, and you will fully indemnify TI and its representatives against, any claims, damages, costs, losses, and liabilities arising out of your use of these resources.

TI's products are provided subject to [TI's Terms of Sale](#) or other applicable terms available either on [ti.com](https://www.ti.com) or provided in conjunction with such TI products. TI's provision of these resources does not expand or otherwise alter TI's applicable warranties or warranty disclaimers for TI products.

TI objects to and rejects any additional or different terms you may have proposed.

Mailing Address: Texas Instruments, Post Office Box 655303, Dallas, Texas 75265
Copyright © 2024, Texas Instruments Incorporated

Looking for pricing, stock, or lifecycle information?

Click below to explore more details on WIN SOURCE:

 [View LM74720QDRRRQ1](#) on WIN SOURCE

 [Texas Instruments](#) Information

Optimize Your Supply Chain with WIN SOURCE Solutions

-  Global Sourcing Solution
-  Obsolete Management
-  Cost Control Management
-  Shortage Management
-  Alternative Solution
-  Excess Inventory Management