



**THE DATASHEET OF  
BQ25173DSGR**



## BQ25173: 800-mA Linear Charger for 1- to 4-Cell Supercapacitor

### 1 Features

- Input voltage up-to 40-V tolerant
- Automatic Sleep mode for low power consumption
  - 350-nA leakage current
  - 2- $\mu$ A input leakage current when charge disabled
- Supports 1- to 4-cell supercapacitor
- Supports charging supercapacitor from 0 V
- External resistor programmable operation
  - FB pin to adjust supercapacitor regulation voltage
  - ISET to set charge current from 10 mA to 800 mA
- High accuracy
  - $\pm 1\%$  charge voltage accuracy
  - $\pm 10\%$  charge current accuracy
- Charging features
  - $\overline{\text{CE}}$  pin for charging function control
  - Open-drain output for status and fault indication
  - Open-drain output for power-good indication
- Integrated fault protection
  - 18-V IN overvoltage protection
  - 1000-mA overcurrent protection
  - 125°C thermal regulation; 150°C thermal shutdown protection
  - OUT short-circuit protection
  - ISET pin short/open protection

### 2 Applications

- [Smart meter](#)
- [Barcode scanner](#)
- [Portable medical equipment](#)
- [Dashboard camera](#)

### 3 Description

The BQ25173 is an integrated 800-mA linear charger for 1- to 4-cell supercapacitors targeted at space-limited applications. The device has a single power output that charges the supercapacitor. The system load can be placed in parallel with the supercapacitor; the charge current is shared between the system and supercapacitor.

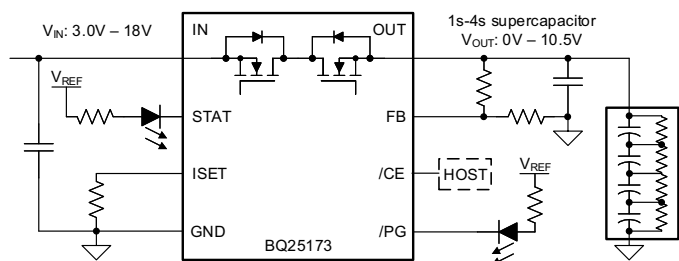
During charging, an internal control loop monitors the IC junction temperature and reduces the charge current if the internal temperature threshold,  $T_{\text{REG}}$ , is exceeded. This feature allows for fast charging of a fully discharged supercapacitor.

The charger power stage and charge current sense functions are fully integrated. The charger function has high accuracy current and voltage regulation loops, charge status display, and charge function control. The charge voltage and fast-charge current are programmable through external resistors.

#### Device Information

PART NUMBER	PACKAGE <sup>(1)</sup>	BODY SIZE (NOM)
BQ25173	WSON (8)	2.0 mm x 2.0 mm

(1) For all available packages, see the orderable addendum at the end of the data sheet.



**Simplified Schematic**



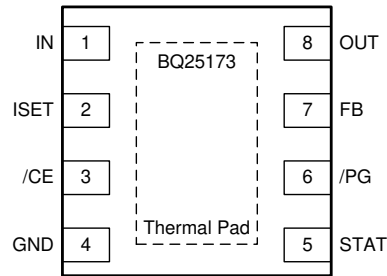
## Table of Contents

<b>1 Features</b> .....	<b>1</b>	<b>8 Application and Implementation</b> .....	<b>16</b>
<b>2 Applications</b> .....	<b>1</b>	8.1 Application Information.....	16
<b>3 Description</b> .....	<b>1</b>	8.2 Typical Applications.....	16
<b>4 Revision History</b> .....	<b>2</b>	<b>9 Power Supply Recommendations</b> .....	<b>20</b>
<b>5 Pin Configuration and Functions</b> .....	<b>3</b>	<b>10 Layout</b> .....	<b>20</b>
<b>6 Specifications</b> .....	<b>4</b>	10.1 Layout Guidelines.....	20
6.1 Absolute Maximum Ratings .....	4	10.2 Layout Example.....	20
6.2 ESD Ratings .....	4	10.3 Thermal Package.....	20
6.3 Recommended Operating Conditions .....	4	<b>11 Device and Documentation Support</b> .....	<b>22</b>
6.4 Thermal Information .....	5	11.1 Device Support.....	22
6.5 Electrical Characteristics .....	6	11.2 Receiving Notification of Documentation Updates..	22
6.6 Timing Requirements .....	7	11.3 Support Resources.....	22
6.7 Typical Characteristics.....	8	11.4 Trademarks.....	22
<b>7 Detailed Description</b> .....	<b>10</b>	11.5 Electrostatic Discharge Caution.....	22
7.1 Overview.....	10	11.6 Glossary.....	22
7.2 Functional Block Diagram.....	11	<b>12 Mechanical, Packaging, and Orderable</b>	
7.3 Feature Description.....	12	<b>Information</b> .....	<b>23</b>
7.4 Device Functional Modes.....	14		

## 4 Revision History

DATE	REVISION	NOTES
November 2021	*	Initial Release

## 5 Pin Configuration and Functions



**Figure 5-1. DSG (WSO) Package 8-Pin Top View**

**Table 5-1. Pin Functions**

PIN		I/O <sup>(1)</sup>	DESCRIPTION
NAME	NO.		
IN	1	P	Input power. Connect to external DC supply. Bypass IN with at least 1- $\mu$ F capacitor to GND, placed close to the IC.
ISET	2	I	Programs the device fast-charge current, $I_{CHG}$ . External resistor from ISET to GND defines fast-charge current value. Expected range is 30 k $\Omega$ (10 mA) to 375 $\Omega$ (800 mA). $I_{CHG} = K_{ISET} / R_{ISET}$ .
$\overline{CE}$	3	I	Active low charge enable pin. Charging is enabled when the CE pin is LOW. IC remains in Shutdown mode and charging is disabled when the CE pin is HIGH. An internal pulldown resistor ( $R_{PD\_CE}$ ) enables the IC by default if this pin is floating.
GND	4	–	Ground pin.
STAT	5	O	Open-drain charger status indication output. Connect to pullup rail with a 10-k $\Omega$ resistor. LOW indicates $V_{OUT}$ has reached 98% of the programmable regulation voltage, $V_{REG}$ . HIGH indicates charge in progress.
$\overline{PG}$	6	O	Open-drain charger power-good output. Connect to pullup rail with a 10-k $\Omega$ resistor. $\overline{PG}$ goes LOW when $V_{IN} > V_{IN\_LOWV}$ and $V_{OUT} + V_{SLEEPZ} < V_{IN} < V_{IN\_OV}$ .
FB	7	I	Programs the supercapacitor regulation voltage, $V_{REG}$ . Use a feedback divider not exceeding 1 M $\Omega$ from $V_{OUT}$ to GND to set the regulation voltage. The bottom of the resistor divider network can be connected to $\overline{PG}$ for reduced power consumption when the input is removed (for $V_{REG} \leq 5$ V).
OUT	8	P	Supercapacitor connection. System load may be connected in parallel with supercapacitor. Bypass OUT with at least 1- $\mu$ F capacitor to GND, placed close to the IC.
Thermal Pad	—	P	Exposed pad beneath the IC for heat dissipation. Solder thermal pad to the board with vias connecting to solid GND plane.

(1) I = Input, O = Output, P = Power

## 6 Specifications

### 6.1 Absolute Maximum Ratings

over operating free-air temperature range (unless otherwise noted)<sup>(1)</sup>

		MIN	MAX	UNIT
Voltage	IN	-0.3	40	V
Voltage	OUT	-0.3	13	V
Voltage	$\overline{CE}$ , FB, ISET, STAT, $\overline{PG}$	-0.3	5.5	V
Output Sink Current	$\overline{PG}$ , STAT		5	mA
Junction temperature, $T_J$		-40	150	°C
Storage temperature, $T_{stg}$		-65	150	°C

- (1) Operation outside the *Absolute Maximum Ratings* may cause permanent device damage. Absolute maximum ratings do not imply functional operation of the device at these or any other conditions beyond those listed under *Recommended Operating Conditions*. If briefly operating outside the *Recommended Operating Conditions* but within the *Absolute Maximum Ratings*, the device may not sustain damage, but it may not be fully functional. Operating the device in this manner may reduce reliability, performance, and shorten the device lifetime.

### 6.2 ESD Ratings

			VALUE	UNIT
$V_{(ESD)}$	Electrostatic discharge	Human body model (HBM), per ANSI/ESDA/ JEDEC JS-001 <sup>(1)</sup>	±2500	V
		Charged device model (CDM), per ANSI/ESDA/ JEDEC JS-002 <sup>(2)</sup>	±1500	

- (1) JEDEC document JEP155 states that 500-V HBM allows safe manufacturing with a standard ESD control process.  
 (2) JEDEC document JEP157 states that 250-V CDM allows safe manufacturing with a standard ESD control process.

### 6.3 Recommended Operating Conditions

over operating free-air temperature range (unless otherwise noted)

		MIN	NOM	MAX	UNIT
$V_{IN}$	Input voltage	3.0		18	V
$V_{OUT}$	Output voltage	0		10.5	V
$I_{OUT}$	Output current			0.8	A
$T_J$	Junction temperature	-40		125	°C
$C_{IN}$	IN capacitor	1			μF
$C_{OUT}$	OUT capacitor	1			μF
$R_{ISET}$	ISET resistor	0.375		30	kΩ

## 6.4 Thermal Information

THERMAL METRIC <sup>(1)</sup>		BQ25173	UNIT
		DSG (WSON)	
		8 PINS	
$R_{\theta JA}$	Junction-to-ambient thermal resistance (JEDEC <sup>(1)</sup> )	75.2	°C/W
$R_{\theta JC(top)}$	Junction-to-case (top) thermal resistance	93.4	°C/W
$R_{\theta JB}$	Junction-to-board thermal resistance	41.8	°C/W
$\Psi_{JT}$	Junction-to-top characterization parameter	3.8	°C/W
$\Psi_{JB}$	Junction-to-board characterization parameter	41.7	°C/W
$R_{\theta JC(bot)}$	Junction-to-case (bottom) thermal resistance	17.0	°C/W

- (1) For more information about traditional and new thermal metrics, see the [Semiconductor and IC Package Thermal Metrics](#) application report.

## 6.5 Electrical Characteristics

$3.0V < V_{IN} < 18V$  and  $V_{IN} > V_{OUT} + V_{SLEEP}$ ,  $T_J = -40^{\circ}C$  to  $+125^{\circ}C$ , and  $T_J = 25^{\circ}C$  for typical values (unless otherwise noted)

PARAMETER		TEST CONDITIONS	MIN	TYP	MAX	UNIT
<b>QUIESCENT CURRENTS</b>						
$I_{Q\_OUT}$	Quiescent output current (OUT)	OUT = 4.2V, IN floating or IN = 0V - 5V, Charge Disabled ( $\overline{CE}$ high), $T_J = 25^{\circ}C$	0.350	0.6		$\mu A$
		OUT = 4.2V, IN floating or IN = 0V - 5V, Charge Disabled ( $\overline{CE}$ high), $T_J < 105^{\circ}C$	0.350	0.8		$\mu A$
$I_{Q\_OUT}$	Quiescent output current (OUT)	OUT = 8.4V, IN floating or IN = 0V - 14V, Charge Disabled ( $\overline{CE}$ high), $T_J = 25^{\circ}C$	0.8	1.2		$\mu A$
		OUT = 8.4V, IN floating or IN = 0V - 14V, Charge Disabled ( $\overline{CE}$ high), $T_J < 105^{\circ}C$	0.8	1.5		$\mu A$
$I_{SD\_IN}$	Shutdown input current (IN) with charge disabled	IN = 5V, Charge Disabled ( $\overline{CE}$ high), no capacitor	2	4		$\mu A$
		IN = 14V, Charge Disabled ( $\overline{CE}$ high), no capacitor	3.5	6		$\mu A$
$I_{Q\_IN}$	Quiescent input current (IN)	IN = 5V, OUT = 3.8V, Charge Enabled ( $\overline{CE}$ low), ICHG = 0A	0.45	0.6		mA
$I_{Q\_IN}$	Quiescent input current (IN)	IN = 14V, OUT = 7.6V, Charge Enabled ( $\overline{CE}$ low), ICHG = 0A	0.45	0.6		mA
<b>INPUT</b>						
$V_{IN\_OP}$	IN operating range		3.0		18	V
$V_{IN\_LOWV}$	IN voltage to start charging	IN rising	3.05	3.09	3.15	V
$V_{IN\_LOWV}$	IN voltage to stop charging	IN falling	2.80	2.95	3.10	V
$V_{SLEEPZ}$	Exit sleep mode threshold	IN rising, $V_{IN} - V_{OUT}$ , OUT = 4V	95	135	175	mV
$V_{SLEEP}$	Sleep mode threshold hysteresis	IN falling, $V_{IN} - V_{OUT}$ , OUT = 4V		80		mV
$V_{IN\_OV}$	VIN overvoltage rising threshold	IN rising	18.1	18.4	18.7	V
$V_{IN\_OVZ}$	VIN overvoltage falling threshold	IN falling		18.2		V
<b>CONFIGURATION PINS SHORT/OPEN PROTECTION</b>						
$R_{ISET\_SHORT}$	Highest resistor value considered short	$R_{ISET}$ below this at startup, charger does not initiate charge, power cycle or $\overline{CE}$ toggle to reset			350	$\Omega$
<b>CHARGER</b>						
$V_{FB\_REF}$	Feedback reference voltage			0.8		V
$V_{FB\_REF\_ACC}$	Feedback reference voltage accuracy	$T_J = -40^{\circ}C$ to $125^{\circ}C$	-1		1	%
$I_{CHG\_RANGE}$	Typical charge current regulation range	$V_{OUT} > V_{BAT\_LOWV}$	10		800	mA
$K_{ISET}$	Charge current setting factor, $I_{CHG} = K_{ISET} / R_{ISET}$	10mA < ICHG < 800mA	270	300	330	A $\Omega$
$I_{CHG\_ACC}$	Charge current accuracy	$R_{ISET} = 375\Omega$ , OUT = 3.8V or 7.6V	720	800	880	mA
		$R_{ISET} = 600\Omega$ , OUT = 3.8V or 7.6V	450	500	550	mA
		$R_{ISET} = 3.0k\Omega$ , OUT = 3.8V or 7.6V	90	100	110	mA
		$R_{ISET} = 30k\Omega$ , OUT = 3.8V or 7.6V	9	10	11	mA
$V_{CHG}$	Supercapacitor charged threshold	OUT rising, as percentage of FB regulation target		98		%
$R_{ON}$	Charging path FET on-resistance	IOUT = 400mA, $T_J = 25^{\circ}C$		845	1000	m $\Omega$
		IOUT = 400mA, $T_J = -40 - 125^{\circ}C$		845	1450	m $\Omega$
<b>CHARGER PROTECTION</b>						
$I_{OUT\_OCP}$	Output current limit threshold	IOUT rising	0.9	1	1.1	A

## 6.5 Electrical Characteristics (continued)

$3.0V < V_{IN} < 18V$  and  $V_{IN} > V_{OUT} + V_{SLEEP}$ ,  $T_J = -40^{\circ}C$  to  $+125^{\circ}C$ , and  $T_J = 25^{\circ}C$  for typical values (unless otherwise noted)

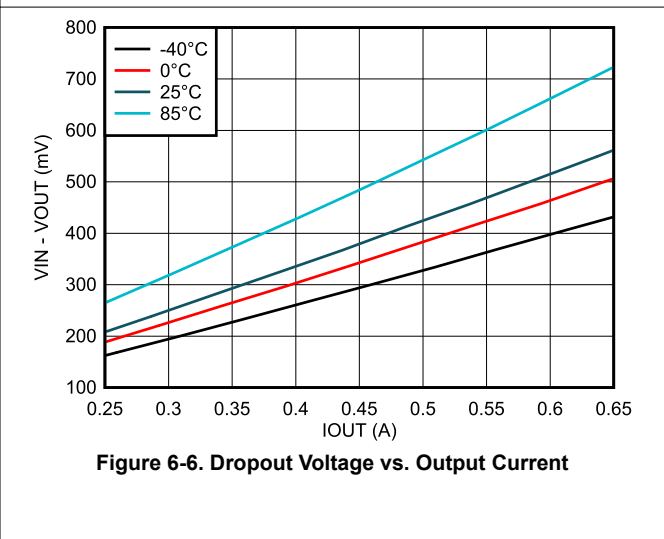
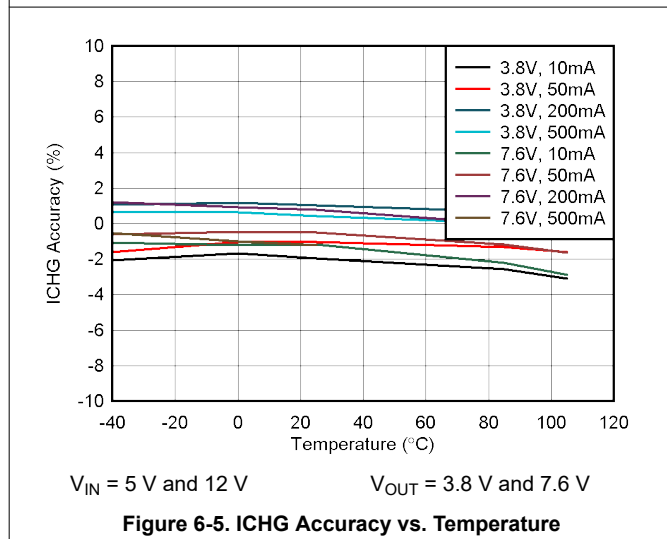
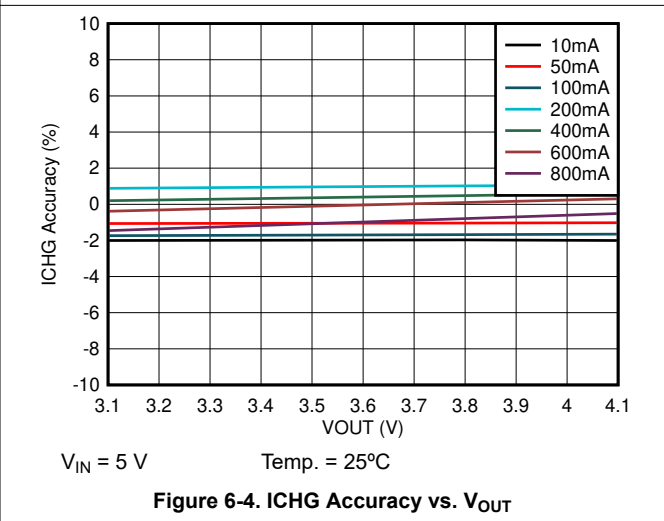
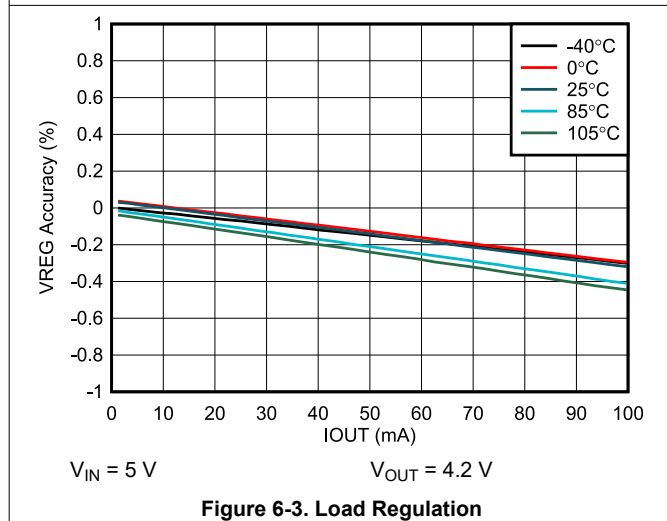
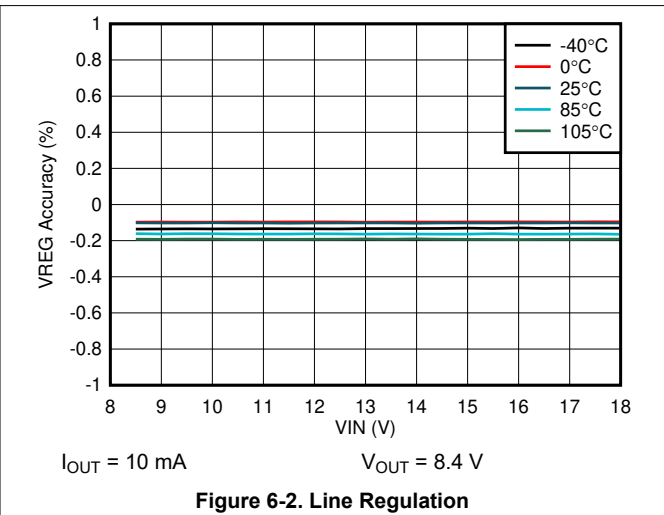
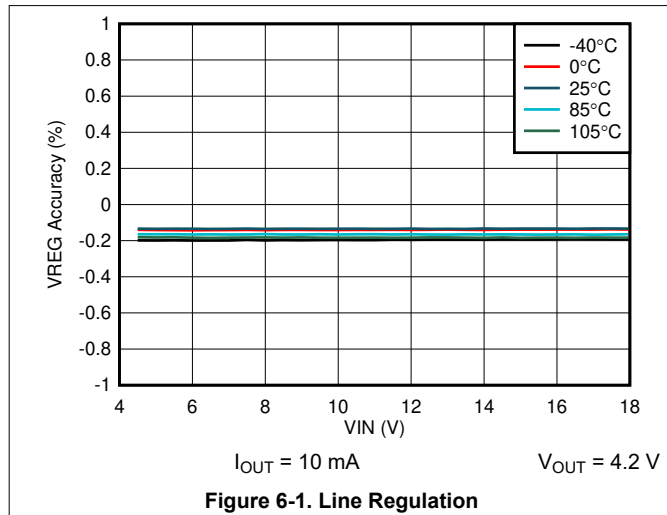
PARAMETER		TEST CONDITIONS	MIN	TYP	MAX	UNIT
<b>TEMPERATURE REGULATION AND TEMPERATURE SHUTDOWN</b>						
$T_{REG}$	Typical junction temperature regulation			125		$^{\circ}C$
$T_{SHUT}$	Thermal shutdown rising threshold	Temperature increasing		150		$^{\circ}C$
	Thermal shutdown falling threshold	Temperature decreasing		135		$^{\circ}C$
<b>LOGIC INPUT PIN (/CE)</b>						
$V_{IH}$	Input high threshold level		1.3			V
$V_{IL}$	Input low threshold level				0.4	V
$R_{PD\_CE}$	$\overline{CE}$ pin internal pulldown resistor		3.3			$M\Omega$
<b>LOGIC OUTPUT PIN (STAT, <math>\overline{PG}</math>)</b>						
$V_{OL}$	Output low threshold level	Sink current = 5mA			0.4	V
$I_{OUT\_BIAS}$	High-level leakage current	Pull up rail 3.3V			1	$\mu A$

## 6.6 Timing Requirements

		MIN	NOM	MAX	UNIT
<b>CHARGER</b>					
$t_{OUT\_OCP\_DGL}$	Deglintch time for $I_{OUT\_OCP}$ , $I_{OUT}$ rising		100		$\mu s$

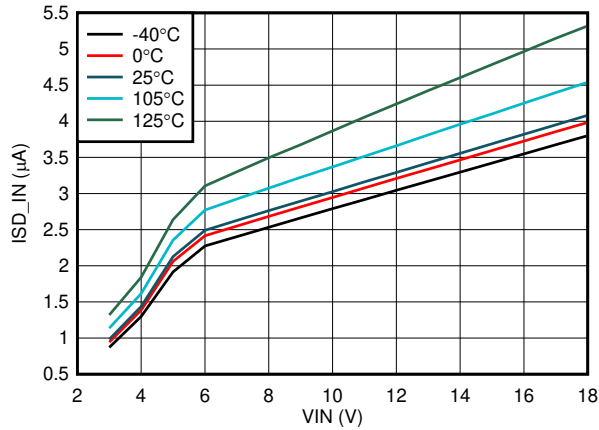
## 6.7 Typical Characteristics

$C_{IN} = 1 \mu F$ ,  $C_{OUT} = 1 \mu F$



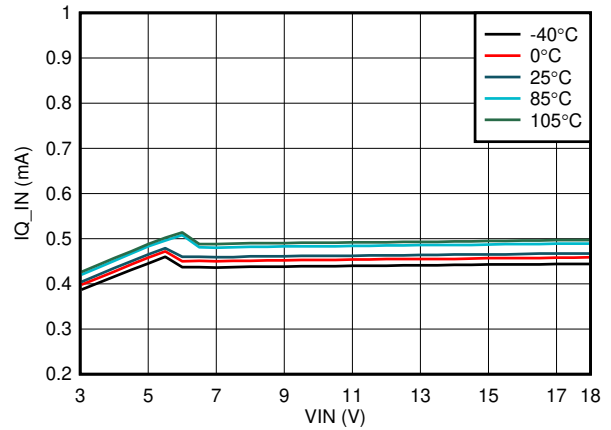
### 6.7 Typical Characteristics (continued)

$C_{IN} = 1 \mu F$ ,  $C_{OUT} = 1 \mu F$



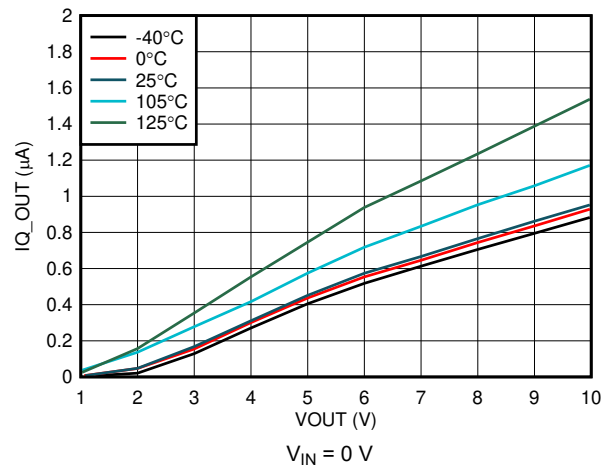
$\overline{CE}$  Pin = HIGH  $V_{OUT} = 0 V$

**Figure 6-7. Input Shutdown Current vs. Input Voltage**



$\overline{CE}$  Pin = LOW  $ICHG = 0 A$

**Figure 6-8. Input Quiescent Current vs. Input Voltage**



$V_{IN} = 0 V$

**Figure 6-9. Output Quiescent Current vs. Output Voltage**

## 7 Detailed Description

### 7.1 Overview

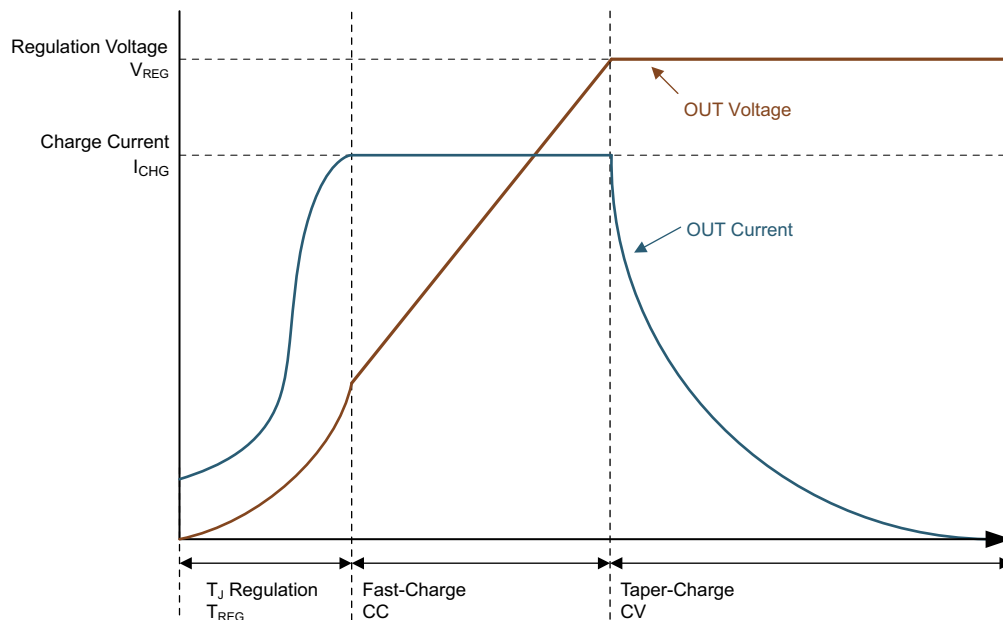
The device has a single power output that charges the supercapacitor. The system load can be placed in parallel with the supercapacitor; the charge current is shared between the system and supercapacitor.

The charger is designed for a single path from the input to the output to charge the supercapacitor. Upon application of a valid input power source, the ISET pin is checked for short/open circuit.

The device attempts to charge the supercapacitor at the fast-charge current setting from fully discharged (0 V) up to the programmable regulation voltage,  $V_{REG}$ . Power dissipation in the IC is greatest in fast charge with a lower supercapacitor voltage. If the IC temperature reaches  $T_{REG}$ , the IC enters thermal regulation and reduces the charge current as needed to keep the temperature from rising any further. The fast-charge current is programmed using the ISET pin. [Figure 7-1](#) shows the typical supercapacitor charging profile with thermal regulation. At lower fast-charge settings, the junction temperature of the IC is less than  $T_{REG}$  and thermal regulation is not entered.

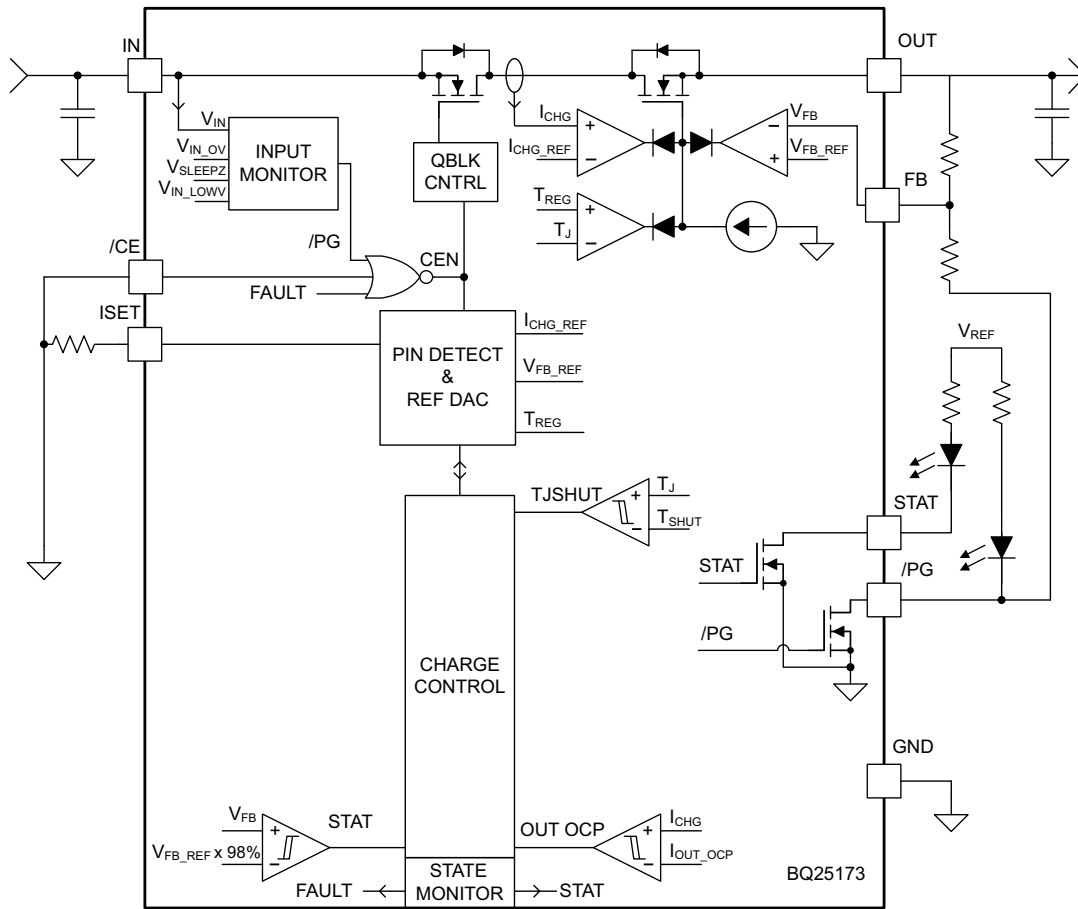
Once the supercapacitor has charged to the regulation voltage, the voltage loop takes control and holds the voltage at the regulation voltage as the current tapers down to zero. There is no current termination threshold as seen in Li-ion chargers.

Further details are described in [Section 7.3](#).



**Figure 7-1. Supercapacitor Charging Profile with Thermal Regulation**

## 7.2 Functional Block Diagram



## 7.3 Feature Description

### 7.3.1 Device Power Up from Input Source

When an input source is plugged in and charge is enabled, the device checks the input source voltage to turn on all of the bias circuits. The device detects and sets the charge current limits before the linear regulator is started. The power-up sequence from the input source is listed below:

1. ISET pin detection
2. Charger power up

#### 7.3.1.1 ISET Pin Detection

After a valid VIN is plugged in and the  $\overline{CE}$  pin is pulled LOW, the device checks the resistor on the ISET pin for a short circuit ( $R_{ISET} < R_{ISET\_SHORT}$ ). If a short condition is detected, the charger remains in the FAULT state until the input or  $\overline{CE}$  pin is toggled. If the ISET pin is open circuit, the charger proceeds through pin detection and starts the charger with no charge current. This pin is monitored during charging and changes in  $R_{ISET}$  while the charger is operating immediately translates to changes in charge current.

An external pulldown resistor ( $\pm 1\%$  or better recommended to minimize charge current error) from the ISET pin to GND sets the charge current as:

$$I_{CHG} = \frac{K_{ISET}}{R_{ISET}} \quad (1)$$

where:

- $I_{CHG}$  is the desired fast-charge current
- $K_{ISET}$  is the gain factor found in the electrical specifications
- $R_{ISET}$  is the pulldown resistor from the ISET pin to GND

For charge currents below 50 mA, an extra RC circuit is recommended on the ISET pin to achieve a more stable current signal. For greater accuracy at lower currents, part of the current-sensing FET is disabled to give better resolution.

### 7.3.2 Supercapacitor Regulation Voltage

The device allows for the supercapacitor regulation voltage,  $V_{REG}$ , to be programmed with a resistor divider between the OUT and FB pins:

$$V_{REG} = V_{FB\_REF} \times \frac{R_{FBT} + R_{FBB}}{R_{FBB}} \quad (2)$$

Where  $V_{FB\_REF}$  is listed in the electrical characteristics table. The resistors can be seen in [Figure 7-2](#). The total resistance ( $R_{FBT} + R_{FBB}$ ) should not exceed 1 M $\Omega$ .

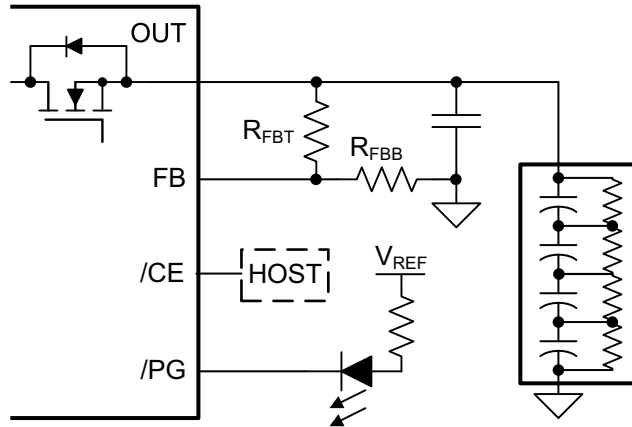


Figure 7-2. BQ25173 Feedback Divider

### 7.3.3 Supercapacitor Charging Profile

The device charges a supercapacitor in two phases: constant current and constant voltage. Power dissipation in the IC is greatest in fast charge with a lower supercapacitor voltage. If the IC temperature reaches  $T_{REG}$ , the IC enters thermal regulation and reduces the charge current as needed to keep the temperature from rising any further. As the supercapacitor approaches the regulation voltage, the current tapers down to 0 mA. There is no current termination threshold as seen in Li-Ion chargers.

### 7.3.4 Status Outputs ( $\overline{PG}$ , STAT)

#### 7.3.4.1 Power Good Indicator ( $\overline{PG}$ Pin)

This open-drain pin pulls LOW to indicate a good input source when:

1.  $V_{IN}$  above  $V_{IN\_LOWV}$
2.  $V_{IN}$  above  $V_{OUT} + V_{SLEEPZ}$  (not in SLEEP)
3.  $V_{IN}$  below  $V_{IN\_OV}$

The  $\overline{PG}$  pin can be used as the GND connection for the bottom resistor in the feedback divider to prevent divider leakage current from the supercapacitor when the charger is disabled. This is only recommended when  $V_{REG} \leq 5$  V (1-2s supercapacitors) as the absolute maximum rating on  $\overline{PG}$  is 5.5 V. An example circuit can be seen in Figure 8-1.

#### 7.3.4.2 Charging Status Indicator (STAT)

The device indicates the charging state on the open-drain STAT pin. This pin can drive an LED.

Table 7-1. STAT Pin State

CHARGING STATE	STAT PIN STATE
$V_{FB} < 98\%$ of $V_{FB\_REF}$	High
$V_{FB} > 98\%$ of $V_{FB\_REF}$	Low
Fault ( $V_{IN}$ OVP, OUT OCP, or ISET pin short)	Blink at 1 Hz

### 7.3.5 Protection Features

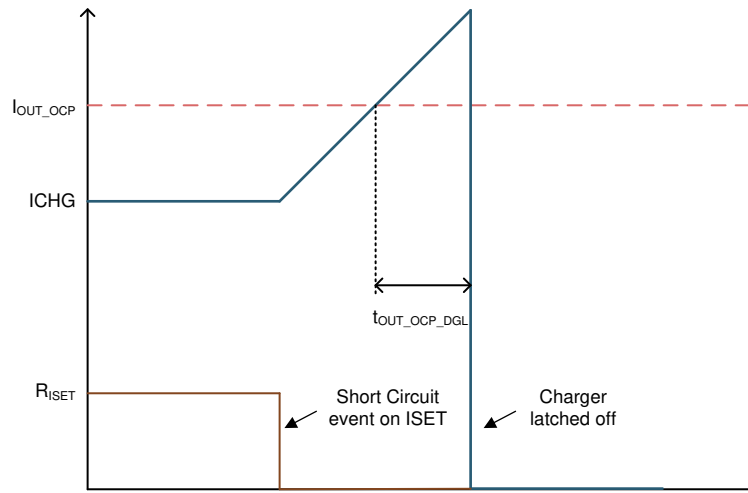
The device closely monitors input and output voltage, as well as internal FET current and temperature for safe linear regulator operation.

#### 7.3.5.1 Input Overvoltage Protection ( $V_{IN}$ OVP)

If the voltage at the IN pin exceeds  $V_{IN\_OV}$ , the device enters STANDBY mode. Once the IN voltage recovers to normal level, charging resumes.

### 7.3.5.2 Output Overcurrent Protection (OUT OCP)

During normal operation, the OUT current should be regulated to the ISET programmed value. However, if a short circuit occurs on the ISET pin, the OUT current may rise to an unintended level. If current at the OUT pin exceeds  $I_{OUT\_OCP}$ , the device turns off after a deglitch,  $t_{OUT\_OCP\_DGL}$ , and the device remains latched off. An input supply or  $\overline{CE}$  pin toggle is required to restart operation.



**Figure 7-3. Overcurrent Protection**

### 7.3.5.3 Thermal Regulation and Thermal Shutdown ( $T_{REG}$ and $T_{SHUT}$ )

The device monitors its internal junction temperature ( $T_J$ ) to avoid overheating and to limit the IC surface temperature. When the internal junction temperature exceeds the thermal regulation limit, the device automatically reduces the charge current to maintain the junction temperature at the thermal regulation limit ( $T_{REG}$ ). During thermal regulation, the actual charging current is usually below the programmed value on the ISET pin.

Additionally, device thermal shutdown turns off the linear regulator when the IC junction temperature exceeds the  $T_{SHUT}$  threshold. The charger resumes operation when the IC die temperature decreases below the  $T_{SHUT}$  falling threshold.

## 7.4 Device Functional Modes

### 7.4.1 Shutdown or Undervoltage Lockout (UVLO)

The device is in the shutdown state if the IN pin voltage is less than  $V_{IN\_LOWV}$ . The internal circuitry is powered down, all the pins are high impedance, and the device draws from the input supply. Once the IN voltage rises above the  $V_{IN\_LOW}$  threshold, the IC will enter Sleep Mode or Active Mode depending on the OUT pin voltage.

### 7.4.2 Sleep Mode

The device is in Sleep Mode when  $V_{IN\_LOWV} < V_{IN} < V_{OUT} + V_{SLEEPZ}$ . The device waits for the input voltage to rise above  $V_{OUT} + V_{SLEEPZ}$  to start operation.

### 7.4.3 Active Mode

The device is powered up and charges the supercapacitor when the  $\overline{CE}$  pin is LOW and the IN voltage ramps above both  $V_{IN\_LOWV}$ , and  $V_{OUT} + V_{SLEEPZ}$ . The device draws  $I_{Q\_IN}$  from the supply to bias the internal circuitry. For details on the device power-up sequence, refer to [Section 7.3.1](#).

#### **7.4.3.1 Standby Mode**

The device is in Standby Mode if a valid input supply is present and a recoverable fault is detected. The internal circuitry is partially biased, and the device continues to monitor for the recoverable fault to be removed.

#### **7.4.4 Fault Mode**

The fault conditions are categorized into recoverable and nonrecoverable as follows:

- Recoverable, from which the device should automatically recover once the fault condition is removed:
  - VIN OVP
- Nonrecoverable, requiring pin or input supply toggle to resume operation:
  - OUT OCP
  - ISET pin short detected

## 8 Application and Implementation

### Note

Information in the following applications sections is not part of the TI component specification, and TI does not warrant its accuracy or completeness. TI's customers are responsible for determining suitability of components for their purposes, as well as validating and testing their design implementation to confirm system functionality.

### 8.1 Application Information

A typical application consists of the device configured as a standalone charger for a 1- to 4-cell supercapacitor. The regulation voltage,  $V_{REG}$ , is configured using a resistor divider between the OUT and FB pins. The charge current is configured using a pull-down resistor on the ISET pin. Pulling the  $\overline{CE}$  pin above  $V_{IH}$  disables the charging function. Charger and input supply status are reported with the STAT and PG pins.

### 8.2 Typical Applications

#### 8.2.1 1s Supercapacitor Charger Design Example

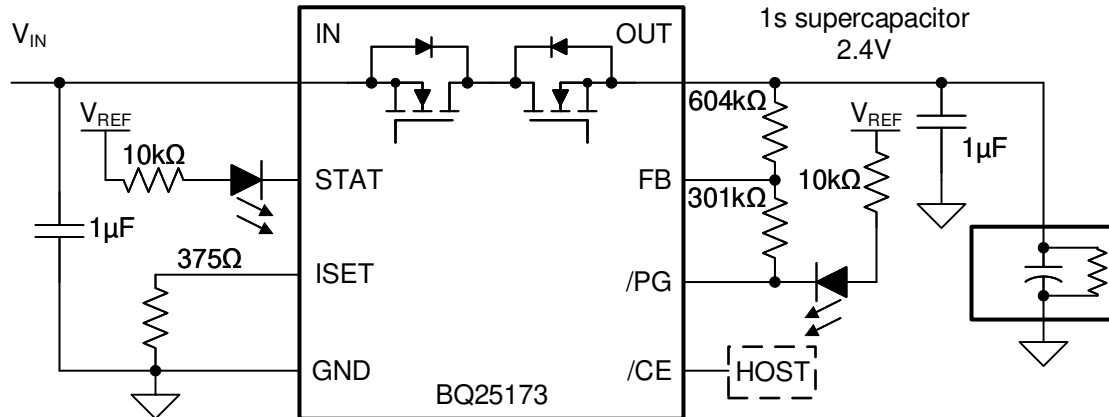


Figure 8-1. BQ25173 1s Supercapacitor Application Diagram

#### 8.2.1.1 Design Requirements

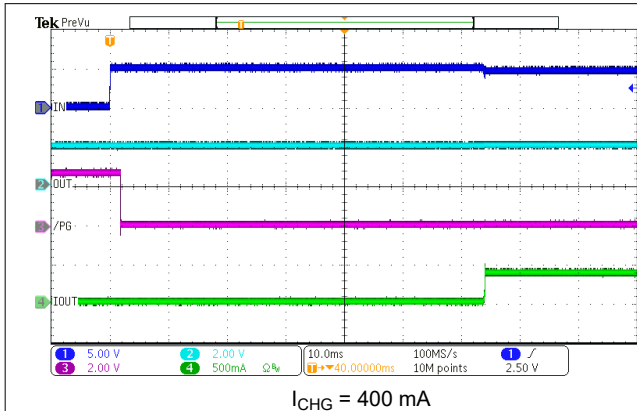
- Supply voltage is 5 V to 18 V
- Fast charge current:  $I_{CHG} = 800 \text{ mA}$
- Regulation voltage:  $V_{REG} = 2.4 \text{ V}$
- $\overline{CE}$  is an open-drain control pin
- $\overline{PG}$  pin is used as the GND connection in the feedback divider to minimize supercapacitor current leakage

#### 8.2.1.2 Detailed Design Procedure

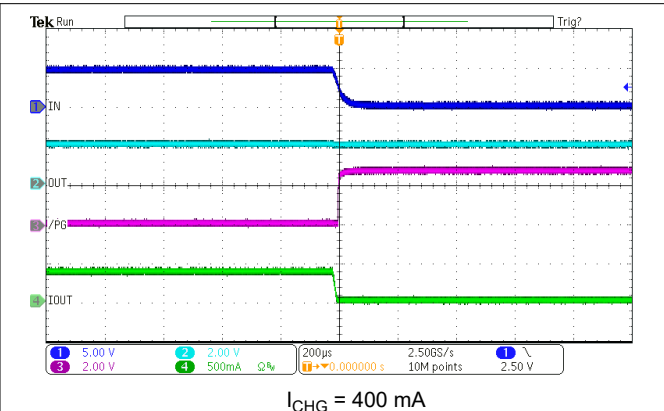
- With  $R_{FBT} = 604 \text{ k}\Omega$ , calculate  $R_{FBB}$  so  $V_{REG} = 2.4 \text{ V}$  using [Equation 2](#)
- $R_{ISET} = [K_{ISET} / I_{CHG}]$  from electrical characteristics table.
  - $K_{ISET} = 300 \text{ A}\Omega$
  - $R_{ISET} = [300 \text{ A}\Omega / 0.8 \text{ A}] = 375 \Omega$

### 8.2.1.3 Application Curves

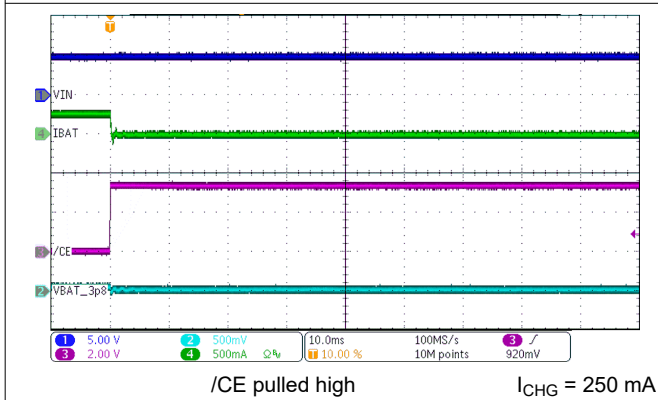
$C_{IN} = 1 \mu\text{F}$ ,  $C_{OUT} = 1 \mu\text{F}$ ,  $C_{SC} = 25 \text{ F}$ ,  $V_{IN} = 5 \text{ V}$  (unless otherwise specified)



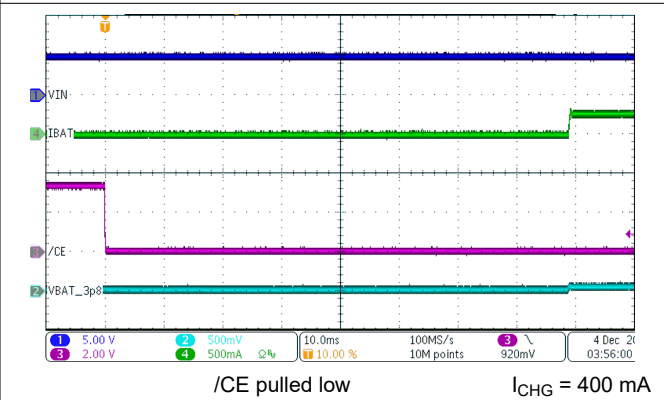
**Figure 8-2. Power Up with Supercapacitor**



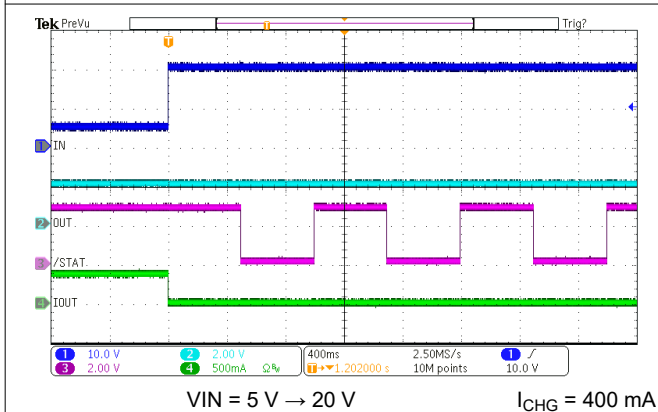
**Figure 8-3. Power Down with Supercapacitor**



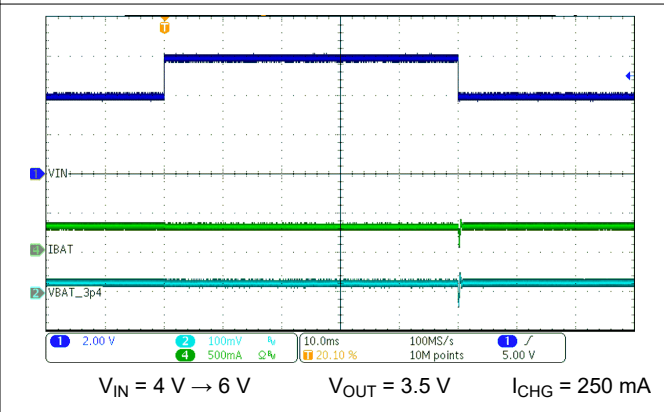
**Figure 8-4. Charge Disable**



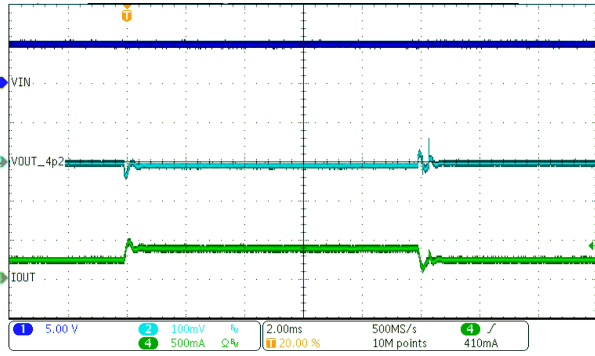
**Figure 8-5. Charge Enable**



**Figure 8-6. IN OVP Response**

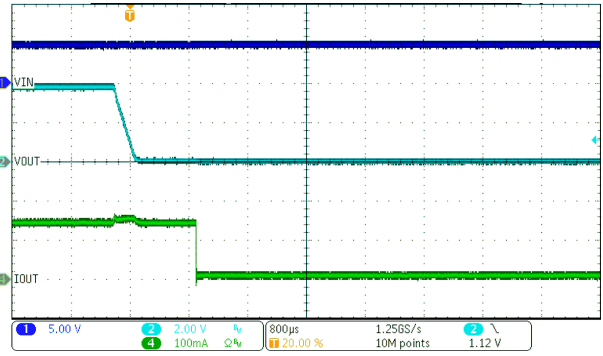


**Figure 8-7. IN Transient Response**



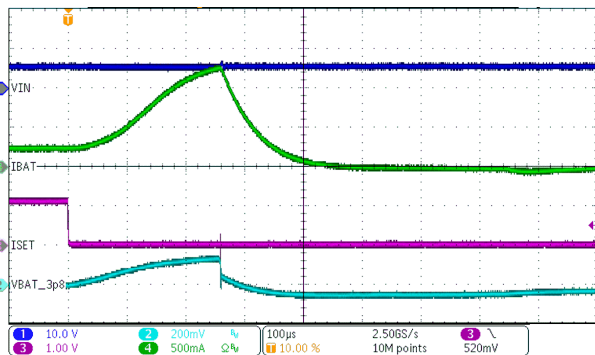
$V_{OUT} = 4.2\text{ V}$   $I_{SYS} = 0\text{ mA} \rightarrow 500\text{ mA}$   $I_{CHG} = 250\text{ mA}$   
 $\text{mA} \rightarrow 0\text{ mA}$

**Figure 8-8. OUT Transient Response**



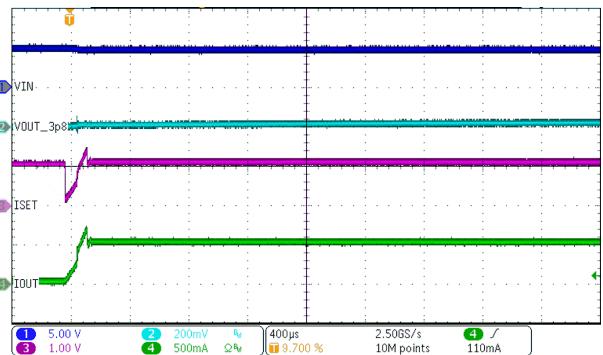
$V_{OUT} = 4.0\text{ V} \rightarrow 0\text{ V}$   $I_{CHG} = 250\text{ mA}$

**Figure 8-9. OUT Short-Circuit Response**



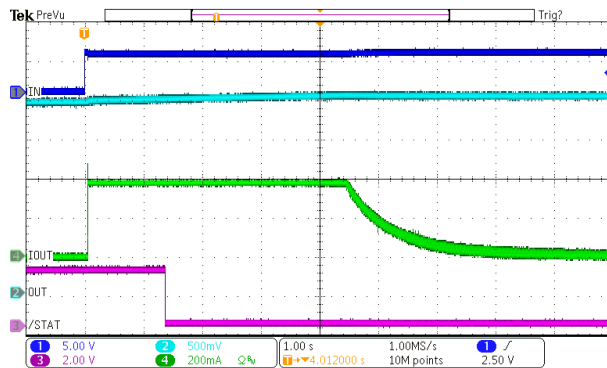
$I_{SET} = 1.2\text{ k}\Omega \rightarrow 0\ \Omega$

**Figure 8-10. ISET Short-Circuit Response**



$I_{SET} = 50\text{ mA} \rightarrow 500\text{ mA}$

**Figure 8-11. ISET Change Response**



$V_{REG} = 2.5\text{ V}$

$I_{CHG} = 400\text{ mA}$

**Figure 8-12. Charge Complete**

## 8.2.2 4s Supercapacitor Charger Design Example

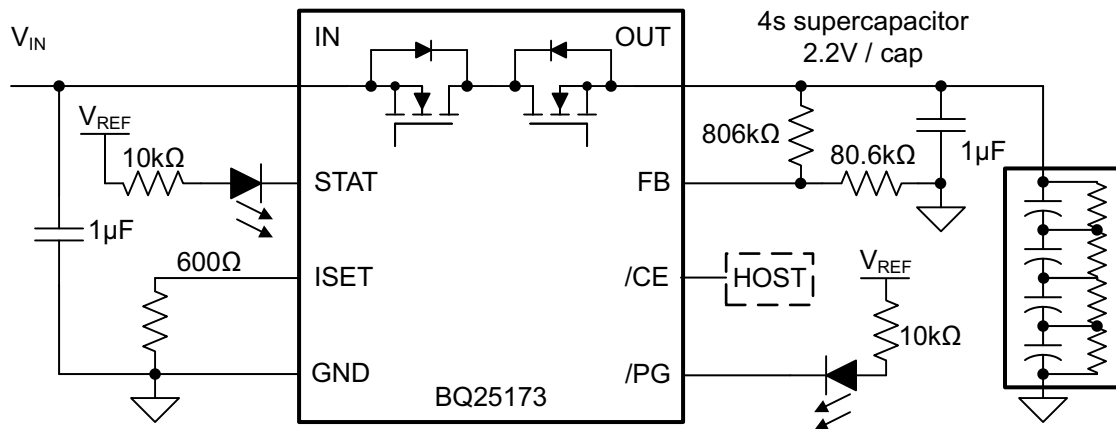


Figure 8-13. BQ25173 4s Supercapacitor Application Diagram

### 8.2.2.1 Design Requirements

The design requirements include the following:

- Supply voltage is 9 V to 18 V
- Fast charge current:  $I_{CHG} = 500 \text{ mA}$
- Regulation voltage:  $V_{REG} = 8.8 \text{ V}$
- $\overline{CE}$  is a control pin, pull high to disable the charger

### 8.2.2.2 Application Curves

For application curves, refer to [Section 8.2.1.3](#).

## 9 Power Supply Recommendations

The device is designed to operate from an input voltage supply range between 3.0 V and 18 V (up to 40 V tolerant) and current capability of at least the maximum designed charge current. If located more than a few inches from the IN and GND pins, a larger capacitor is recommended.

## 10 Layout

### 10.1 Layout Guidelines

To obtain optimal performance, the decoupling capacitor from IN to GND and the output filter capacitor from OUT to GND should be placed as close as possible to the device, with short trace runs to both IN, OUT, and GND.

- All low-current GND connections should be kept separate from the high-current charge or discharge paths from the supercapacitor. Use a single-point ground technique incorporating both the small signal ground path and the power ground path.
- The high-current charge paths into the IN pin and from the OUT pin must be sized appropriately for the maximum charge current in order to avoid voltage drops in these traces.

### 10.2 Layout Example

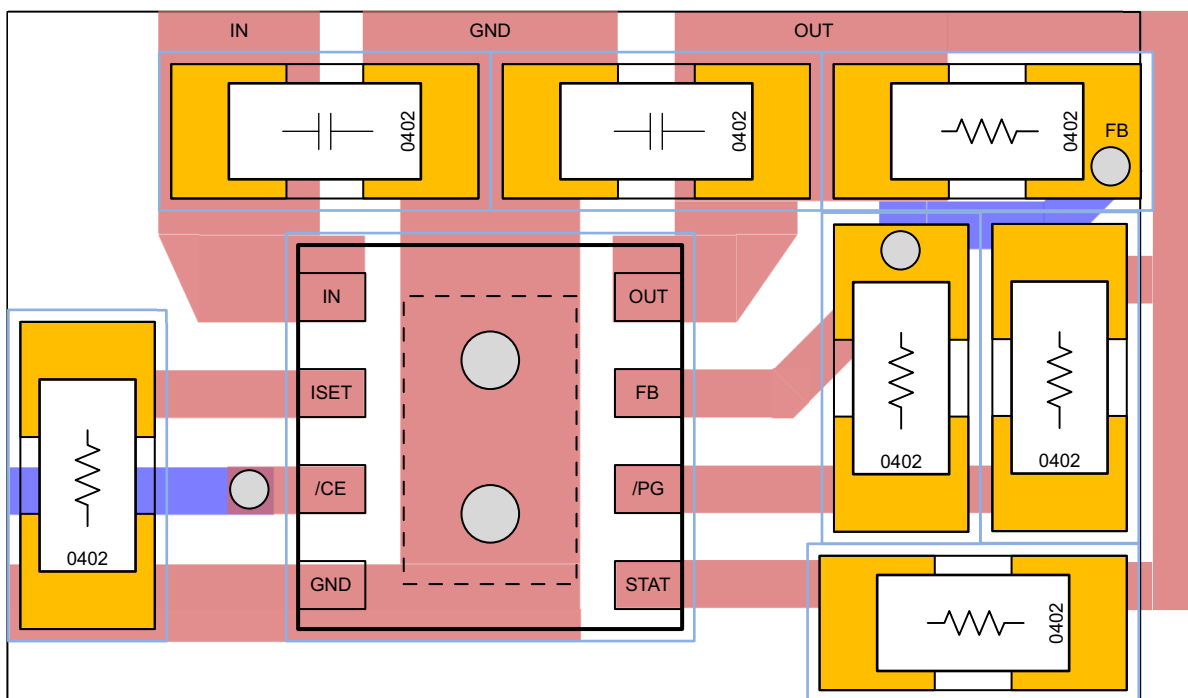


Figure 10-1. BQ25173 Board Layout Example

### 10.3 Thermal Package

The most common measure of package thermal performance is thermal impedance ( $\theta_{JA}$ ) measured (or modeled) from the chip junction to the air surrounding the package surface (ambient). The mathematical expression for  $\theta_{JA}$  is:

$$\theta_{JA} = (T_J - T) / P \quad (3)$$

Where:

$T_J$  = chip junction temperature

$T$  = ambient temperature

$P$  = device power dissipation

Factors that can influence the measurement and calculation of  $\theta_{JA}$  include:

- Whether or not the device is board mounted
- Trace size, composition, thickness, and geometry
- Orientation of the device (horizontal or vertical)
- Volume of the ambient air surrounding the device under test and airflow
- Whether other surfaces are in close proximity to the device being tested

Due to the charge profile of supercapacitors, maximum power dissipation is typically seen at the beginning of the charge cycle when the voltage is at its lowest.

Device power dissipation,  $P$ , is a function of the charge rate and the voltage drop across the internal PowerFET.  $P$  can be calculated from the following equation during charging:

$$P = [V_{(IN)} - V_{(OUT)}] \times I_{(OUT)} \quad (4)$$

The thermal loop feature reduces the charge current to limit excessive IC junction temperature. It is recommended that the design not run in thermal regulation for typical operating conditions (nominal input voltage and nominal ambient temperatures) and use the feature for nontypical situations such as hot environments or higher than normal input source voltage. With that said, the IC will still perform as described, if the thermal loop is always active.

## 11 Device and Documentation Support

### 11.1 Device Support

#### 11.1.1 Third-Party Products Disclaimer

TI'S PUBLICATION OF INFORMATION REGARDING THIRD-PARTY PRODUCTS OR SERVICES DOES NOT CONSTITUTE AN ENDORSEMENT REGARDING THE SUITABILITY OF SUCH PRODUCTS OR SERVICES OR A WARRANTY, REPRESENTATION OR ENDORSEMENT OF SUCH PRODUCTS OR SERVICES, EITHER ALONE OR IN COMBINATION WITH ANY TI PRODUCT OR SERVICE.

#### 11.2 Receiving Notification of Documentation Updates

To receive notification of documentation updates, navigate to the device product folder on [ti.com](http://ti.com). Click on *Subscribe to updates* to register and receive a weekly digest of any product information that has changed. For change details, review the revision history included in any revised document.

#### 11.3 Support Resources

[TI E2E™ support forums](#) are an engineer's go-to source for fast, verified answers and design help — straight from the experts. Search existing answers or ask your own question to get the quick design help you need.

Linked content is provided "AS IS" by the respective contributors. They do not constitute TI specifications and do not necessarily reflect TI's views; see TI's [Terms of Use](#).

#### 11.4 Trademarks

TI E2E™ is a trademark of Texas Instruments.

All trademarks are the property of their respective owners.

#### 11.5 Electrostatic Discharge Caution



This integrated circuit can be damaged by ESD. Texas Instruments recommends that all integrated circuits be handled with appropriate precautions. Failure to observe proper handling and installation procedures can cause damage.

ESD damage can range from subtle performance degradation to complete device failure. Precision integrated circuits may be more susceptible to damage because very small parametric changes could cause the device not to meet its published specifications.

#### 11.6 Glossary

[TI Glossary](#) This glossary lists and explains terms, acronyms, and definitions.

## **12 Mechanical, Packaging, and Orderable Information**

The following pages include mechanical, packaging, and orderable information. This information is the most current data available for the designated devices. This data is subject to change without notice and revision of this document. For browser-based versions of this data sheet, refer to the left-hand navigation.

**PACKAGING INFORMATION**

Orderable Device	Status (1)	Package Type	Package Drawing	Pins	Package Qty	Eco Plan (2)	Lead finish/ Ball material (6)	MSL Peak Temp (3)	Op Temp (°C)	Device Marking (4/5)	Samples
BQ25173DSGR	ACTIVE	WSON	DSG	8	3000	RoHS & Green	NIPDAU	Level-1-260C-UNLIM	-40 to 125	B173	Samples

(1) The marketing status values are defined as follows:

**ACTIVE:** Product device recommended for new designs.

**LIFEBUY:** TI has announced that the device will be discontinued, and a lifetime-buy period is in effect.

**NRND:** Not recommended for new designs. Device is in production to support existing customers, but TI does not recommend using this part in a new design.

**PREVIEW:** Device has been announced but is not in production. Samples may or may not be available.

**OBSELETE:** TI has discontinued the production of the device.

(2) **RoHS:** TI defines "RoHS" to mean semiconductor products that are compliant with the current EU RoHS requirements for all 10 RoHS substances, including the requirement that RoHS substance do not exceed 0.1% by weight in homogeneous materials. Where designed to be soldered at high temperatures, "RoHS" products are suitable for use in specified lead-free processes. TI may reference these types of products as "Pb-Free".

**RoHS Exempt:** TI defines "RoHS Exempt" to mean products that contain lead but are compliant with EU RoHS pursuant to a specific EU RoHS exemption.

**Green:** TI defines "Green" to mean the content of Chlorine (Cl) and Bromine (Br) based flame retardants meet JS709B low halogen requirements of <=1000ppm threshold. Antimony trioxide based flame retardants must also meet the <=1000ppm threshold requirement.

(3) MSL, Peak Temp. - The Moisture Sensitivity Level rating according to the JEDEC industry standard classifications, and peak solder temperature.

(4) There may be additional marking, which relates to the logo, the lot trace code information, or the environmental category on the device.

(5) Multiple Device Markings will be inside parentheses. Only one Device Marking contained in parentheses and separated by a "~" will appear on a device. If a line is indented then it is a continuation of the previous line and the two combined represent the entire Device Marking for that device.

(6) Lead finish/Ball material - Orderable Devices may have multiple material finish options. Finish options are separated by a vertical ruled line. Lead finish/Ball material values may wrap to two lines if the finish value exceeds the maximum column width.

**Important Information and Disclaimer:**The information provided on this page represents TI's knowledge and belief as of the date that it is provided. TI bases its knowledge and belief on information provided by third parties, and makes no representation or warranty as to the accuracy of such information. Efforts are underway to better integrate information from third parties. TI has taken and continues to take reasonable steps to provide representative and accurate information but may not have conducted destructive testing or chemical analysis on incoming materials and chemicals. TI and TI suppliers consider certain information to be proprietary, and thus CAS numbers and other limited information may not be available for release.

In no event shall TI's liability arising out of such information exceed the total purchase price of the TI part(s) at issue in this document sold by TI to Customer on an annual basis.

**TAPE AND REEL INFORMATION**

**QUADRANT ASSIGNMENTS FOR PIN 1 ORIENTATION IN TAPE**


\*All dimensions are nominal

Device	Package Type	Package Drawing	Pins	SPQ	Reel Diameter (mm)	Reel Width W1 (mm)	A0 (mm)	B0 (mm)	K0 (mm)	P1 (mm)	W (mm)	Pin1 Quadrant
BQ25173DSGR	WSON	DSG	8	3000	180.0	8.4	2.3	2.3	1.15	4.0	8.0	Q2

**TAPE AND REEL BOX DIMENSIONS**


\*All dimensions are nominal

Device	Package Type	Package Drawing	Pins	SPQ	Length (mm)	Width (mm)	Height (mm)
BQ25173DSGR	WSON	DSG	8	3000	210.0	185.0	35.0

## GENERIC PACKAGE VIEW

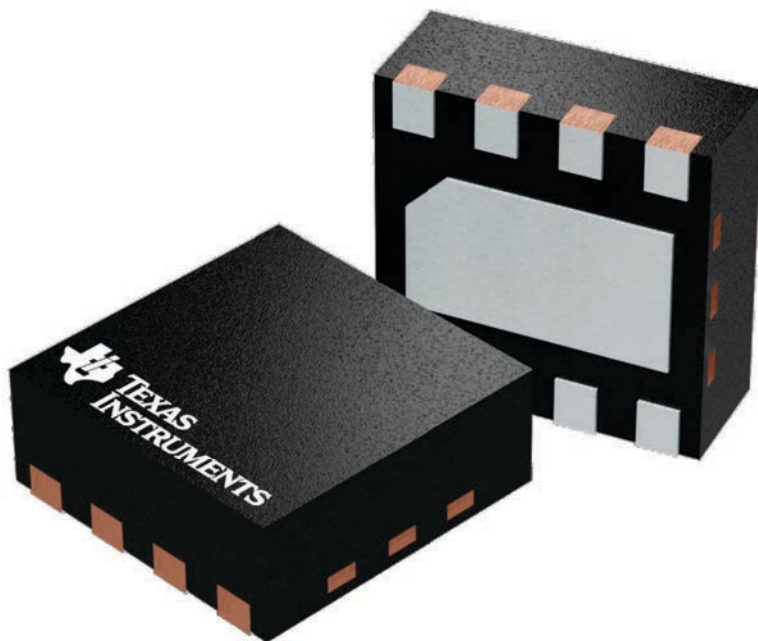
**DSG 8**

**WSON - 0.8 mm max height**

2 x 2, 0.5 mm pitch

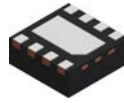
PLASTIC SMALL OUTLINE - NO LEAD

This image is a representation of the package family, actual package may vary.  
Refer to the product data sheet for package details.



4224783/A

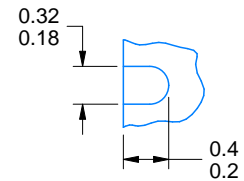
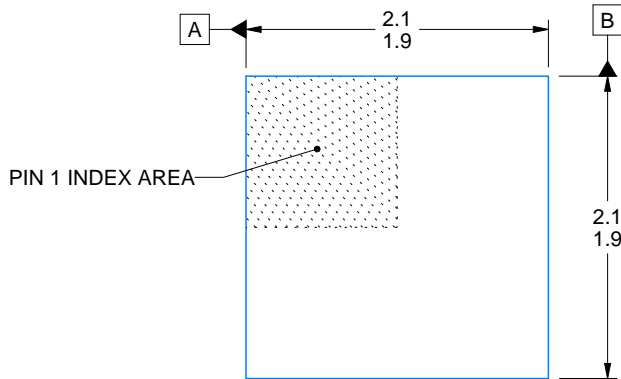
# DSG0008A



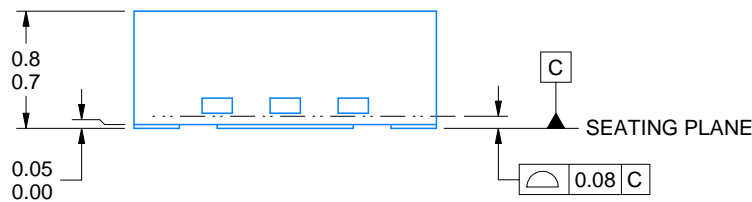
# PACKAGE OUTLINE

## WSON - 0.8 mm max height

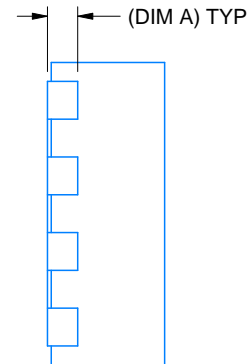
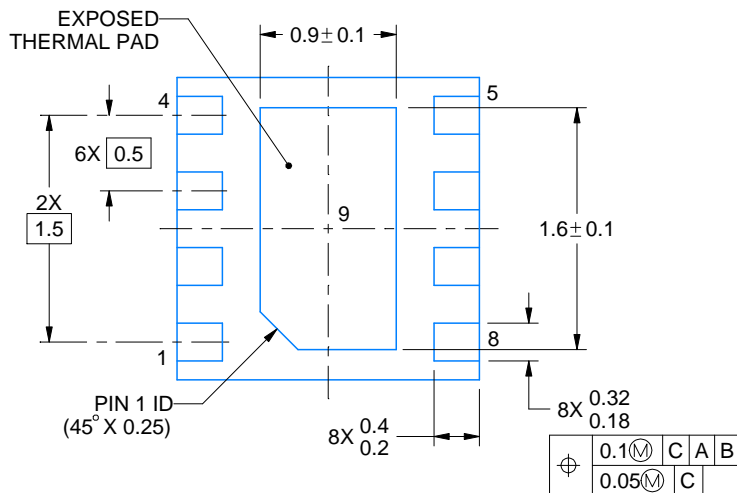
PLASTIC SMALL OUTLINE - NO LEAD



ALTERNATIVE TERMINAL SHAPE TYPICAL



SIDE WALL METAL THICKNESS DIM A	
OPTION 1	OPTION 2
0.1	0.2



4218900/E 08/2022

### NOTES:

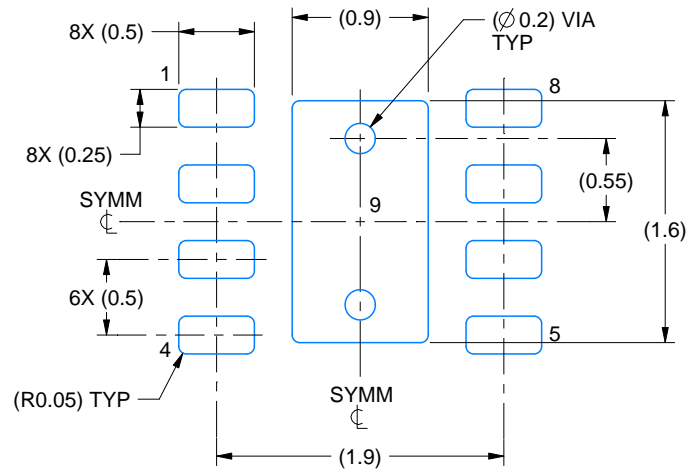
1. All linear dimensions are in millimeters. Any dimensions in parenthesis are for reference only. Dimensioning and tolerancing per ASME Y14.5M.
2. This drawing is subject to change without notice.
3. The package thermal pad must be soldered to the printed circuit board for thermal and mechanical performance.

# EXAMPLE BOARD LAYOUT

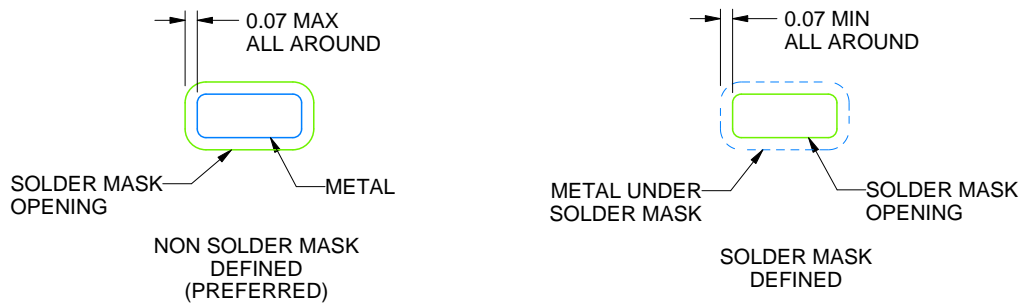
DSG0008A

WSON - 0.8 mm max height

PLASTIC SMALL OUTLINE - NO LEAD



LAND PATTERN EXAMPLE  
SCALE:20X



SOLDER MASK DETAILS

4218900/E 08/2022

NOTES: (continued)

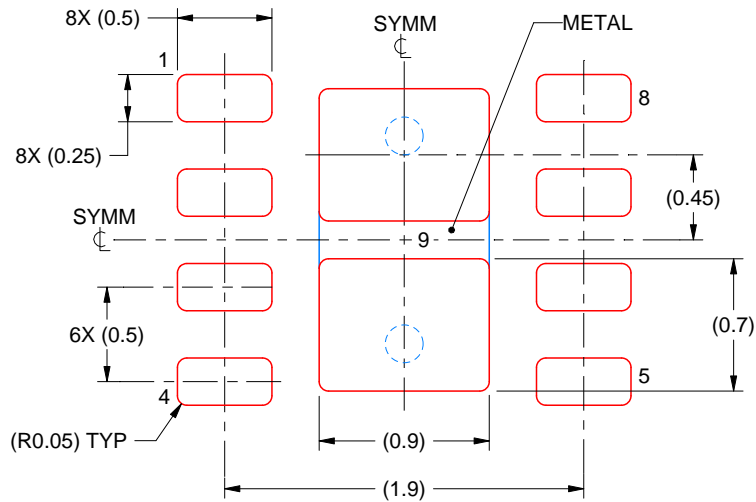
4. This package is designed to be soldered to a thermal pad on the board. For more information, see Texas Instruments literature number SLUA271 ([www.ti.com/lit/slua271](http://www.ti.com/lit/slua271)).
5. Vias are optional depending on application, refer to device data sheet. If any vias are implemented, refer to their locations shown on this view. It is recommended that vias under paste be filled, plugged or tented.

# EXAMPLE STENCIL DESIGN

DSG0008A

WSON - 0.8 mm max height

PLASTIC SMALL OUTLINE - NO LEAD



SOLDER PASTE EXAMPLE  
BASED ON 0.125 mm THICK STENCIL

EXPOSED PAD 9:  
87% PRINTED SOLDER COVERAGE BY AREA UNDER PACKAGE  
SCALE:25X

4218900/E 08/2022

NOTES: (continued)

6. Laser cutting apertures with trapezoidal walls and rounded corners may offer better paste release. IPC-7525 may have alternate design recommendations.

## IMPORTANT NOTICE AND DISCLAIMER

TI PROVIDES TECHNICAL AND RELIABILITY DATA (INCLUDING DATA SHEETS), DESIGN RESOURCES (INCLUDING REFERENCE DESIGNS), APPLICATION OR OTHER DESIGN ADVICE, WEB TOOLS, SAFETY INFORMATION, AND OTHER RESOURCES "AS IS" AND WITH ALL FAULTS, AND DISCLAIMS ALL WARRANTIES, EXPRESS AND IMPLIED, INCLUDING WITHOUT LIMITATION ANY IMPLIED WARRANTIES OF MERCHANTABILITY, FITNESS FOR A PARTICULAR PURPOSE OR NON-INFRINGEMENT OF THIRD PARTY INTELLECTUAL PROPERTY RIGHTS.

These resources are intended for skilled developers designing with TI products. You are solely responsible for (1) selecting the appropriate TI products for your application, (2) designing, validating and testing your application, and (3) ensuring your application meets applicable standards, and any other safety, security, regulatory or other requirements.

These resources are subject to change without notice. TI grants you permission to use these resources only for development of an application that uses the TI products described in the resource. Other reproduction and display of these resources is prohibited. No license is granted to any other TI intellectual property right or to any third party intellectual property right. TI disclaims responsibility for, and you will fully indemnify TI and its representatives against, any claims, damages, costs, losses, and liabilities arising out of your use of these resources.

TI's products are provided subject to [TI's Terms of Sale](#) or other applicable terms available either on [ti.com](https://www.ti.com) or provided in conjunction with such TI products. TI's provision of these resources does not expand or otherwise alter TI's applicable warranties or warranty disclaimers for TI products.

TI objects to and rejects any additional or different terms you may have proposed.

Mailing Address: Texas Instruments, Post Office Box 655303, Dallas, Texas 75265  
Copyright © 2023, Texas Instruments Incorporated

## Looking for pricing, stock, or lifecycle information?

Click below to explore more details on WIN SOURCE:

 [View BQ25173DSGR](#) on WIN SOURCE

 [Texas Instruments](#) Information

## Optimize Your Supply Chain with WIN SOURCE Solutions

-  Global Sourcing Solution
-  Obsolete Management
-  Cost Control Management
-  Shortage Management
-  Alternative Solution
-  Excess Inventory Management