



THE DATASHEET OF BUF634AIDDAR



BUF634A 36-V, 210-MHz, 250-mA Output, High-Speed Buffer

1 Features

- Pin-Selected Bandwidth: 35 MHz to 210 MHz
- High Output Current: 250 mA
- Slew Rate: 3750 V/ μ s
- Low Quiescent Current: 1.5 mA (35-MHz BW)
- Wide Supply Range: ± 2.25 V to ± 18 V
- Internal Output Current Limit
- Thermal Shutdown Protection
- Available in Packages with Thermal Pad
- Extended Temperature Operation: -40°C to $+125^{\circ}\text{C}$

2 Applications

- [Memory, Semiconductor Testers](#)
- [Test Equipment](#)
- [Headphone Drivers](#)
- [Flight Control Systems](#)
- [Capacitive Load Drivers](#)
- [Valve Drivers, Solenoid Drivers](#)
- [Line Drivers](#)

3 Description

The BUF634A device is a high-performance, high-fidelity, open-loop buffer that is capable of driving 250 mA of output current. The BUF634A is a 36-V device with an adjustable bandwidth of 35 MHz to 210 MHz, which is accomplished by varying the value of an external resistor between the V $-$ and BW pins.

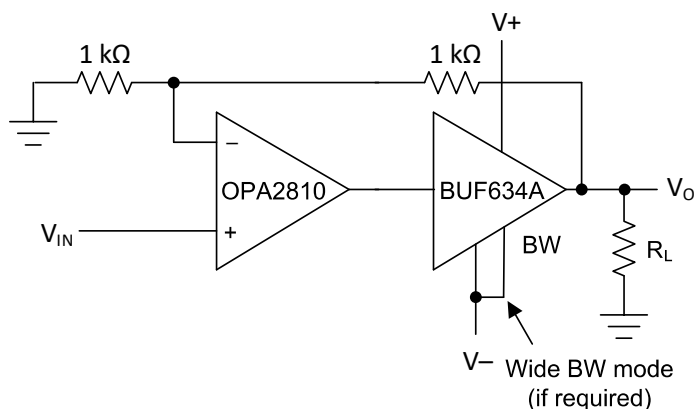

Boost the Output Current of Any Operational Amplifier

The BUF634A device can be used as a standalone open-loop driver, or used inside the feedback loop of a precision op amp to provide both high-precision and large output current drive with improved capacitive load drive.

For low-power applications, the BUF634A device operates on a 1.5-mA quiescent current with a 250-mA output, 3750-V/ μ s slew rate, and 35-MHz bandwidth. The device consumes 8.5-mA quiescent current in wide-bandwidth mode with a 210-MHz bandwidth. The BUF634A is fully protected by an internal current limit in its output stage and by thermal shutdown, making the device rugged and easy to use.

The BUF634A device is rated to function over the extended industrial temperature range of -40°C to $+125^{\circ}\text{C}$. The BUF634A comes in three packages: D (SOIC), DRB (VSON), and DDA (HSOIC). The DRB (VSON) and DDA (HSOIC) packages have excellent thermal performance resulting from the thermal pad on the bottom side. The DRB package comes in a very small form factor of 3.0 mm \times 3.0 mm, making the device a very suitable option for portable and size-constrained applications.

Device Information⁽¹⁾

| PART NUMBER | PACKAGE | BODY SIZE (NOM) |
|-------------|-----------|--------------------------|
| BUF634A | SOIC (8) | 4.90 mm \times 3.90 mm |
| | VSON (8) | 3.00 mm \times 3.00 mm |
| | HSOIC (8) | 4.90 mm \times 3.90 mm |

(1) For all available packages, see the orderable addendum at the end of the data sheet.

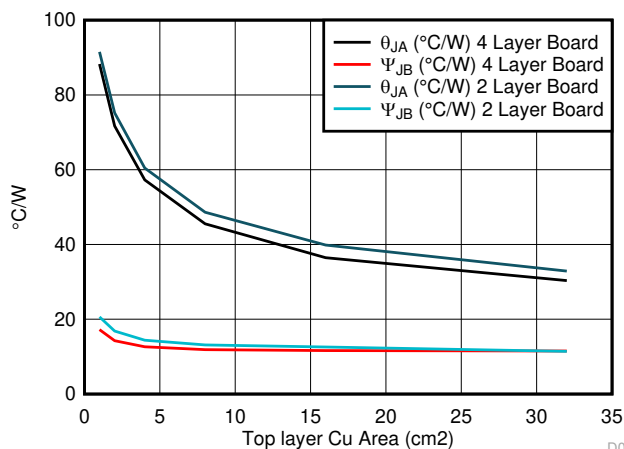

Thermal Performance vs Cu Area for the DDA Package

D037



Table of Contents

| | | | |
|---|----|--|----|
| 1 Features | 1 | 8.4 Device Functional Modes..... | 15 |
| 2 Applications | 1 | 9 Application and Implementation | 16 |
| 3 Description | 1 | 9.1 Application Information..... | 16 |
| 4 Revision History | 2 | 9.2 Typical Application..... | 18 |
| 5 Device Comparison Table | 3 | 10 Power Supply Recommendations | 20 |
| 6 Pin Configuration and Functions | 3 | 10.1 Power Dissipation and Thermal Considerations..... | 20 |
| 7 Specifications | 4 | 11 Layout | 21 |
| 7.1 Absolute Maximum Ratings | 4 | 11.1 Layout Guidelines..... | 21 |
| 7.2 ESD Ratings | 4 | 11.2 Layout Example..... | 23 |
| 7.3 Recommended Operating Conditions | 4 | 12 Device and Documentation Support | 24 |
| 7.4 Thermal Information | 4 | 12.1 Device Support..... | 24 |
| 7.5 Electrical Characteristics: Wide-Bandwidth Mode | 5 | 12.2 Documentation Support..... | 24 |
| 7.6 Electrical Characteristics: Low-Quiescent Current Mode | 6 | 12.3 Receiving Notification of Documentation Updates..... | 24 |
| 7.7 Typical Characteristics..... | 7 | 12.4 Support Resources..... | 24 |
| 8 Detailed Description | 13 | 12.5 Trademarks..... | 25 |
| 8.1 Overview..... | 13 | 12.6 Electrostatic Discharge Caution..... | 25 |
| 8.2 Functional Block Diagram..... | 13 | 12.7 Glossary..... | 25 |
| 8.3 Feature Description..... | 14 | 13 Mechanical, Packaging, and Orderable Information | 25 |

4 Revision History

NOTE: Page numbers for previous revisions may differ from page numbers in the current version.

| | |
|---|-------------|
| Changes from Revision E (December 2020) to Revision F (May 2021) | Page |
| • Replaced the <i>THD+N vs Frequency Using the BUF634A with the OPA2810 (V_O = 10 V_{PP}, 90-kHz Measurement Bandwidth)</i> figure with the <i>Thermal Performance vs Cu Area for the DDA Package</i> figure..... | 1 |
| Changes from Revision D (September 2020) to Revision E (December 2020) | Page |
| • Deleted <i>preview</i> statement for BUF634A VSON package..... | 1 |
| • Deleted <i>preview</i> statement for the DRB package..... | 3 |
| Changes from Revision C (June 2020) to Revision D (September 2020) | Page |
| • Updated the numbering format for tables, figures, and cross-references throughout the document..... | 1 |
| • Added DRB package outline to <i>Mechanical, Packaging, and Orderable Information</i> section..... | 25 |
| Changes from Revision B (January 2020) to Revision C (June 2020) | Page |
| • Deleted <i>preview</i> statement for BUF634A HSOIC package..... | 1 |
| • Deleted <i>preview</i> statement for the D and DDA packages..... | 3 |
| Changes from Revision A (May 2019) to Revision B (January 2020) | Page |
| • Added DRB (VSON) and DDA (HSOIC) packages to document..... | 1 |
| • Changed <i>Applications</i> section..... | 1 |
| • Changed last paragraph of <i>Description</i> section | 1 |
| • Added discussion of V _{IN} pin to <i>ESD Protection</i> section..... | 14 |
| • Added <i>Power Dissipation and Thermal Considerations</i> section..... | 20 |
| • Added <i>HSOIC Layout Guidelines (DDA Package With a Thermal Pad)</i> section..... | 22 |
| • Changed title of <i>BUF634A Layout Example</i> image..... | 23 |
| Changes from Revision * (February 2019) to Revision A (May 2019) | Page |
| • Changed document status from Advance Information to Production Data | 1 |

5 Device Comparison Table

| DEVICE | $V_{S\pm}$ (V) | I_Q / CHANNEL (mA) | BW (MHz) | SLEW RATE (V/ μ s) | VOLTAGE NOISE (nV/ $\sqrt{\text{Hz}}$) | AMPLIFIER DESCRIPTION |
|---------|----------------|----------------------|----------|------------------------|---|--|
| BUF634A | ± 18 | 1.5 – 8.5 | 35 – 210 | 3750 | 3.4 | Unity-gain, open-loop buffer |
| BUF634 | ± 18 | 1.5 – 15 | 30 – 180 | 2000 | 4 | Unity-gain, open-loop buffer |
| LMH6321 | ± 18 | 11 | 110 | 1800 | 2.8 | Unity-gain, open-loop buffer with adjustable current limit |

6 Pin Configuration and Functions

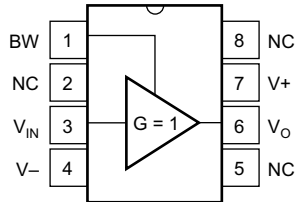

Figure 6-1. D and DDA Packages 8-Pin SOIC, 8-Pin HSOIC with Thermal Pad Top View

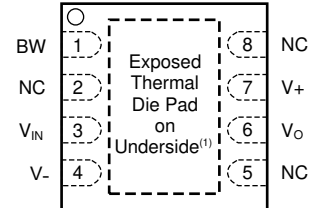

Figure 6-2. DRB Package 8-Pin VSON with Thermal Pad Top View

Table 6-1. Pin Functions

| NAME | PIN | | | I/O ⁽²⁾ | DESCRIPTION |
|-----------------|--------------------|--------------------|---------|--------------------|--|
| | DDA ⁽¹⁾ | DRB ⁽¹⁾ | D | | |
| BW | 1 | 1 | 1 | I | Bandwidth adjust pin. Connect the BW pin to the V– pin for wide-BW mode and leave the BW pin floating for low- I_Q mode. See the Adjustable Bandwidth section. |
| NC | 2, 5, 8 | 2, 5, 8 | 2, 5, 8 | — | No internal connection |
| V– | 4 | 4 | 4 | P | Negative power supply |
| V+ | 7 | 7 | 7 | P | Positive power supply |
| V _{IN} | 3 | 3 | 3 | I | Input |
| V _O | 6 | 6 | 6 | O | Output |
| Thermal Pad | | | — | — | Thermal pad. Must be electrically shorted to V–. |

- (1) The DRB and DDA packages include a thermal pad on the backside of the device. The thermal pad must be connected to the same potential as V–. Connect the thermal pad and V– to a heat-spreading plane to achieve low thermal impedance. The thermal pad can also be unused (not connected to any heat-spreading plane or voltage), thus giving an overall higher thermal impedance.
- (2) I = input, O = output, P = power.

7 Specifications

7.1 Absolute Maximum Ratings

over operating free-air temperature range (unless otherwise noted)⁽¹⁾

| | | MIN | MAX | UNIT |
|---------------------|----------------------------------|-----|---------------|------|
| $V_S = (V+) - (V-)$ | Supply voltage | | 40 (±20) | V |
| V_{IN} | Input voltage | | $V_S \pm 0.5$ | V |
| | Output short-circuit (to ground) | | Continuous | |
| T_A | Operating ambient temperature | -40 | 125 | °C |
| T_J | Junction temperature | | 150 | °C |
| T_{stg} | Storage temperature | -65 | 150 | °C |

- (1) Stresses beyond those listed under *Absolute Maximum Rating* may cause permanent damage to the device. These are stress ratings only, which do not imply functional operation of the device at these or any other conditions beyond those indicated under *Recommended Operating Condition*. Exposure to absolute-maximum-rated conditions for extended periods may affect device reliability.

7.2 ESD Ratings

| | | | VALUE | UNIT |
|-------------|-------------------------|--|-------|------|
| $V_{(ESD)}$ | Electrostatic discharge | Human body model (HBM), per ANSI/ESDA/JEDEC JS-001 ⁽¹⁾ | ±3000 | V |
| | | Charged device model (CDM), per JEDEC specification JESD22-C101 ⁽²⁾ | ±1000 | |

- (1) JEDEC document JEP155 states that 500-V HBM allows safe manufacturing with a standard ESD control process.
 (2) JEDEC document JEP157 states that 250-V CDM allows safe manufacturing with a standard ESD control process.

7.3 Recommended Operating Conditions

over operating free-air temperature range (unless otherwise noted)

| | | MIN | NOM | MAX | UNIT |
|---------------------|---------------------|-------|-----|--------------------|------|
| $V_S = (V+) - (V-)$ | Supply voltage | ±2.25 | ±15 | ±18 | V |
| T_A | Ambient temperature | -40 | 25 | 125 ⁽¹⁾ | °C |

- (1) Limited by $R_{\theta JA}$ and $T_{J,Max}$ for safe operation. See the Output Current section.

7.4 Thermal Information

| THERMAL METRIC ⁽¹⁾ | | BUF634A | | | UNIT |
|-------------------------------|--|----------|------------|-------------|------|
| | | D (SOIC) | DRB (VSON) | DDA (HSOIC) | |
| | | 8 PINS | 8 PINS | 8 PINS | |
| $R_{\theta JA}$ | Junction-to-ambient thermal resistance | 122.9 | 51 | 41.3 | °C/W |
| $R_{\theta JC(top)}$ | Junction-to-case (top) thermal resistance | 55.2 | 58 | 57.1 | °C/W |
| $R_{\theta JB}$ | Junction-to-board thermal resistance | 68.4 | 23.8 | 17.0 | °C/W |
| Ψ_{JT} | Junction-to-top characterization parameter | 12.1 | 1.7 | 4.6 | °C/W |
| Ψ_{JB} | Junction-to-board characterization parameter | 67.2 | 23.8 | 17.0 | °C/W |
| $R_{\theta JC(bot)}$ | Junction-to-case (bottom) thermal resistance | NA | 9.0 | 5.3 | °C/W |

- (1) For more information about traditional and new thermal metrics, see the [Semiconductor and IC Package Thermal Metrics](#) application report.

7.5 Electrical Characteristics: Wide-Bandwidth Mode

at $T_A = 25^\circ\text{C}$, $V_S = \pm 15\text{ V}$, BW pin connected to V_- , and $R_L = 100\ \Omega$ connected to mid-supply (unless otherwise noted).

| PARAMETER | | TEST CONDITIONS | MIN | TYP | MAX | UNIT |
|-------------------------|---|--|------------|-----------|-----------|-------------------------------|
| AC PERFORMANCE | | | | | | |
| BW | Bandwidth, –3 dB | $R_L = 1\ \text{k}\Omega$ | | 210 | | MHz |
| | | $R_L = 100\ \Omega$ | | 200 | | |
| | Bandwidth for 0.1-dB flatness | $V_O = 10\ \text{mV}_{PP}$, $R_L = 100\ \Omega$, $R_S = 50\ \Omega$ | | 50 | | MHz |
| SR | Slew rate | $V_O = 20\text{-V step}$, $V_{IN}\text{-SR} = 4000\ \text{V}/\mu\text{s}$ | | 3750 | | $\text{V}/\mu\text{s}$ |
| | Rise and fall time | $V_O = 200\text{-mV step}$ | | 1.3 | | ns |
| | Settling time to 0.1% | $V_O = 20\text{-V step}$, $V_{IN}\text{-SR} = 2500\ \text{V}/\mu\text{s}$ | | 90 | | ns |
| | Settling time to 1% | $V_O = 20\text{-V step}$, $V_{IN}\text{-SR} = 2500\ \text{V}/\mu\text{s}$ | | 20 | | ns |
| e_n | Voltage noise | $f = 1\ \text{kHz}$ | | 3.4 | | $\text{nV}/\sqrt{\text{Hz}}$ |
| i_n | Current noise | $f = 100\ \text{kHz}$ | | 0.85 | | $\text{pA}/\sqrt{\text{Hz}}$ |
| HD2 | 2nd-harmonic distortion | $V_O = 2\ \text{V}_{PP}$, $f = 20\ \text{kHz}$ | | –77 | | dBc |
| | | $V_O = 10\ \text{V}_{PP}$, $f = 20\ \text{kHz}$ | | –69 | | |
| HD3 | 3rd-harmonic distortion | $V_O = 2\ \text{V}_{PP}$, $f = 20\ \text{kHz}$ | | –77 | | dBc |
| | | $V_O = 10\ \text{V}_{PP}$, $f = 20\ \text{kHz}$ | | –56 | | |
| DC PERFORMANCE | | | | | | |
| V_{OS} | Input offset voltage | $T_A = 25^\circ\text{C}$ | | 36 | 65 | mV |
| | Input offset voltage drift ⁽¹⁾ | $T_A = -40^\circ\text{C to } 125^\circ\text{C}$ | | 175 | | $\mu\text{V}/^\circ\text{C}$ |
| I_B | Input bias current | $V_{IN} = 0\ \text{V}$ | | 0.25 | 2 | μA |
| G | Gain | $V_O = \pm 10\ \text{V}$, $R_L = 1\ \text{k}\Omega$ | 0.95 | 0.99 | | V/V |
| | | $V_O = \pm 10\ \text{V}$, $R_L = 100\ \Omega$ | 0.93 | 0.95 | | |
| | | $V_O = \pm 10\ \text{V}$, $R_L = 67\ \Omega$ | 0.91 | 0.93 | | |
| INPUT | | | | | | |
| | Linear input voltage range | $R_L = 1\ \text{k}\Omega$, $I_B < 10\ \mu\text{A}$ | –13 | | 13 | V |
| Z_{IN} | Input impedance | $R_L = 100\ \Omega$ | | 180 5 | | $\text{M}\Omega \text{pF}$ |
| OUTPUT | | | | | | |
| | Output headroom to supplies | $I_O = \pm 10\ \text{mA}$ | | 1.6 | 1.8 | V |
| | | $I_O = \pm 100\ \text{mA}$ | | 2.0 | 2.2 | |
| | | $I_O = \pm 150\ \text{mA}$ | | 2.2 | 2.5 | |
| I_O | Current output, continuous | | | ± 250 | | mA |
| I_{SC} | Short-circuit current | | | ± 375 | ± 550 | mA |
| Z_O | Output impedance | DC, $I_O = 10\ \text{mA}$ | | 5 | | Ω |
| POWER SUPPLY | | | | | | |
| V_S | Operating voltage range | | ± 2.25 | | ± 18 | V |
| I_Q | Quiescent current | $I_O = 0\ \text{mA}$ | | 8.5 | 12 | mA |
| PSRR | Power-supply rejection ratio | $V_S = \pm 2.25\ \text{V to } \pm 18\ \text{V}$ | 64 | 75 | | dB |
| THERMAL SHUTDOWN | | | | | | |
| | Thermal shutdown temperature | | | 180 | | $^\circ\text{C}$ |

(1) Based on electrical characterization over temperature of 35 devices.

7.6 Electrical Characteristics: Low-Quiescent Current Mode

at $T_A = 25^\circ\text{C}$, $V_S = \pm 15\text{ V}$, BW pin left open, and $R_L = 100\ \Omega$ connected to mid-supply (unless otherwise noted).

| PARAMETER | | TEST CONDITIONS | MIN | TYP | MAX | UNIT |
|-------------------------|---|---|------------|-----------|-----------|-------------------------------|
| AC PERFORMANCE | | | | | | |
| BW | Bandwidth, -3 dB | $R_L = 1\ \text{k}\Omega$ | | 35 | | MHz |
| | | $R_L = 100\ \Omega$ | | 31 | | |
| | Bandwidth for 0.1-dB flatness | $V_O = 10\ \text{mV}_{PP}$, $R_L = 100\ \Omega$, $R_S = 50\ \Omega$ | | 2.3 | | MHz |
| SR | Slew rate | $V_O = 20\text{-V step}$, $V_{IN-SR} = 4000\ \text{V}/\mu\text{s}$ | | 3750 | | $\text{V}/\mu\text{s}$ |
| | Rise and fall time | $V_O = 200\text{-mV step}$ | | 4 | | ns |
| | Settling time to 0.1% | $V_O = 20\text{-V step}$, $V_{IN-SR} = 2500\ \text{V}/\mu\text{s}$ | | 400 | | ns |
| | Settling time to 1% | $V_O = 20\text{-V step}$, $V_{IN-SR} = 2500\ \text{V}/\mu\text{s}$ | | 90 | | ns |
| e_n | Voltage noise | $f = 1\ \text{kHz}$ | | 8.1 | | $\text{nV}/\sqrt{\text{Hz}}$ |
| i_n | Current noise | $f = 10\ \text{kHz}$ | | 0.3 | | $\text{pA}/\sqrt{\text{Hz}}$ |
| HD2 | 2nd-harmonic distortion | $V_O = 2\ \text{V}_{PP}$, $f = 20\ \text{kHz}$ | | -54 | | dBc |
| | | $V_O = 10\ \text{V}_{PP}$, $f = 20\ \text{kHz}$ | | -65 | | |
| HD3 | 3rd-harmonic distortion | $V_O = 2\ \text{V}_{PP}$, $f = 20\ \text{kHz}$ | | -40 | | dBc |
| | | $V_O = 10\ \text{V}_{PP}$, $f = 20\ \text{kHz}$ | | -44 | | |
| DC PERFORMANCE | | | | | | |
| V_{OS} | Input offset voltage | $T_A = 25^\circ\text{C}$ | | 36 | 65 | mV |
| | Input offset voltage drift ⁽¹⁾ | $T_A = -40^\circ\text{C to } 125^\circ\text{C}$ | | 175 | | $\mu\text{V}/^\circ\text{C}$ |
| I_B | Input bias current | $V_{IN} = 0\ \text{V}$ | | 0.03 | 0.25 | μA |
| G | Gain | $V_O = \pm 10\ \text{V}$, $R_L = 1\ \text{k}\Omega$ | 0.95 | 0.99 | | V/V |
| | | $V_O = \pm 10\ \text{V}$, $R_L = 100\ \Omega$ | 0.93 | 0.95 | | |
| | | $V_O = \pm 10\ \text{V}$, $R_L = 67\ \Omega$ | 0.91 | 0.93 | | |
| INPUT | | | | | | |
| | Linear input voltage range | $R_L = 1\ \text{k}\Omega$, $I_B < 10\ \mu\text{A}$ | -13 | | 13 | V |
| Z_{IN} | Input impedance | $R_L = 100\ \Omega$ | | 1400 5 | | $\text{M}\Omega \text{pF}$ |
| OUTPUT | | | | | | |
| | Output headroom to supplies | $I_O = \pm 10\ \text{mA}$ | | 1.6 | 1.8 | V |
| | | $I_O = \pm 100\ \text{mA}$ | | 2.0 | 2.2 | |
| | | $I_O = \pm 150\ \text{mA}$ | | 2.2 | 2.5 | |
| I_O | Current output, continuous | | | ± 250 | | mA |
| I_{SC} | Short-circuit current | | | ± 350 | ± 550 | mA |
| Z_O | Output impedance | DC, $I_O = 10\ \text{mA}$ | | 7 | | Ω |
| POWER SUPPLY | | | | | | |
| V_S | Operating voltage range | | ± 2.25 | | ± 18 | V |
| I_Q | Quiescent current | $I_O = 0$ | | 1.5 | 2.3 | mA |
| PSRR | Power-supply rejection ratio | $V_S = \pm 2.25\ \text{V to } \pm 18\ \text{V}$ | 64 | 80 | | dB |
| THERMAL SHUTDOWN | | | | | | |
| | Thermal shutdown temperature | | | 180 | | $^\circ\text{C}$ |

(1) Based on electrical characterization over temperature of 35 devices.

7.7 Typical Characteristics

At $T_A = 25^\circ\text{C}$, $V_S = \pm 15\text{ V}$, $R_S = 50\ \Omega$, and $R_L = 100\ \Omega$ (unless otherwise noted).

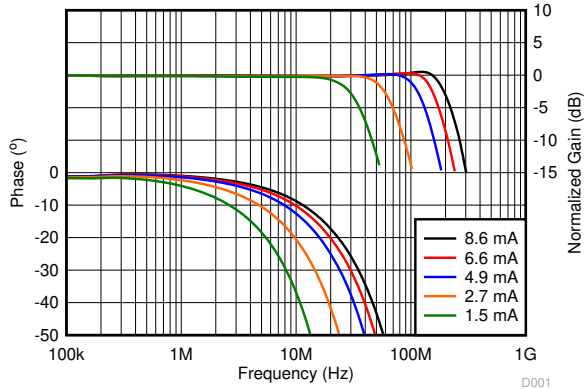
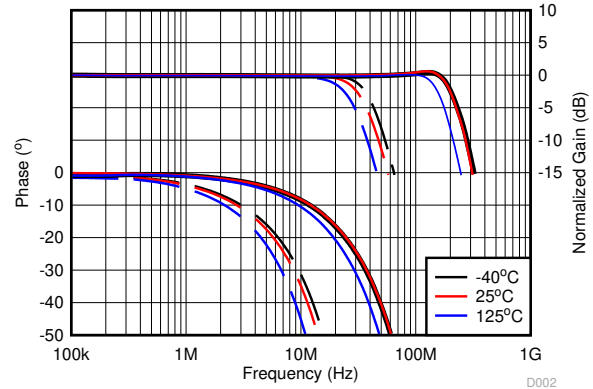
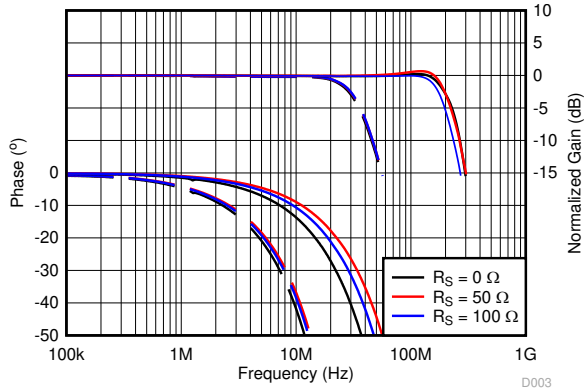

Figure 7-1. Gain and Phase vs Frequency and Quiescent Current



Solid lines indicate wide-BW mode, dashed lines indicate low- I_Q mode

Figure 7-2. Gain and Phase vs Frequency and Temperature



Solid lines indicate wide-BW mode, dashed lines indicate low- I_Q mode

Figure 7-3. Gain and Phase vs Frequency and Source Resistance

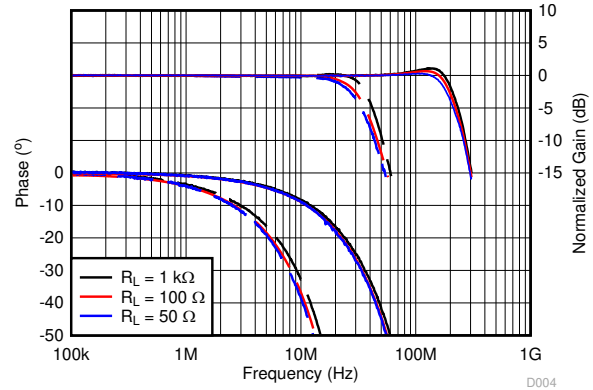

Solid lines indicate wide-BW mode, dashed lines indicate low- I_Q mode

Figure 7-4. Gain and Phase vs Frequency and Load Resistance

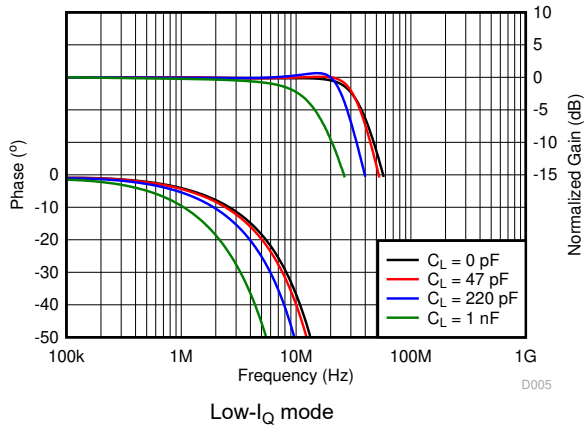

Figure 7-5. Gain and Phase vs Frequency and Load Capacitance

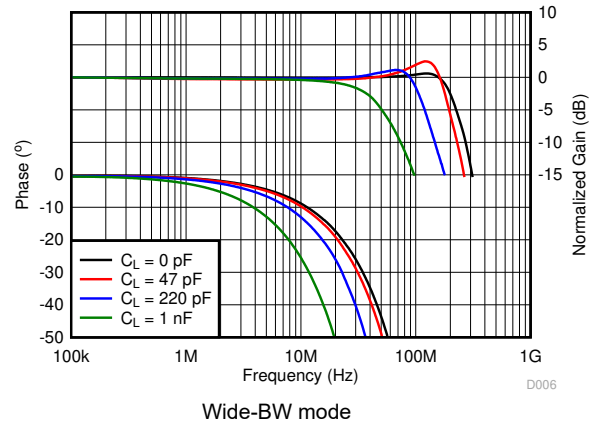
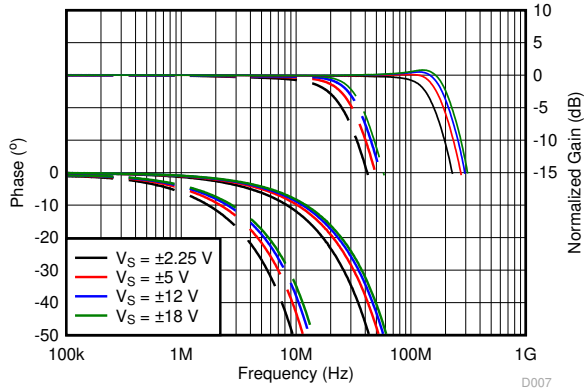

Figure 7-6. Gain and Phase vs Frequency and Load Capacitance

7.7 Typical Characteristics (continued)

At $T_A = 25^\circ\text{C}$, $V_S = \pm 15\text{ V}$, $R_S = 50\ \Omega$, and $R_L = 100\ \Omega$ (unless otherwise noted).



Solid lines indicate wide-BW mode, dashed lines indicate low- I_Q mode

Figure 7-7. Gain and Phase vs Frequency and Power-Supply Voltage

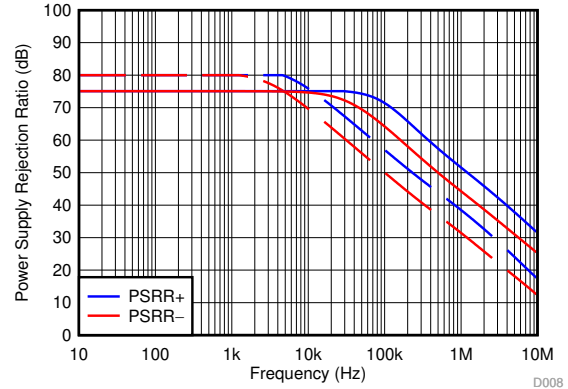

Solid lines indicate wide-BW mode, dashed lines indicate low- I_Q mode

Figure 7-8. PSRR vs Frequency

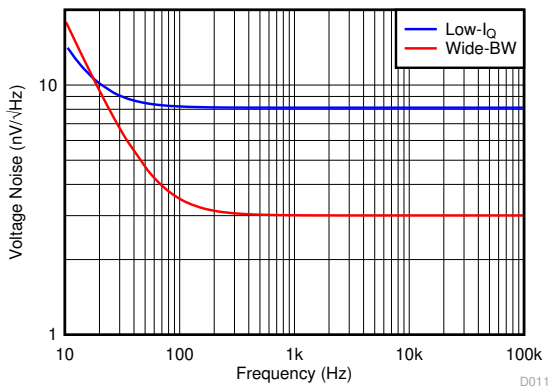

Figure 7-9. Voltage Noise Density vs Frequency

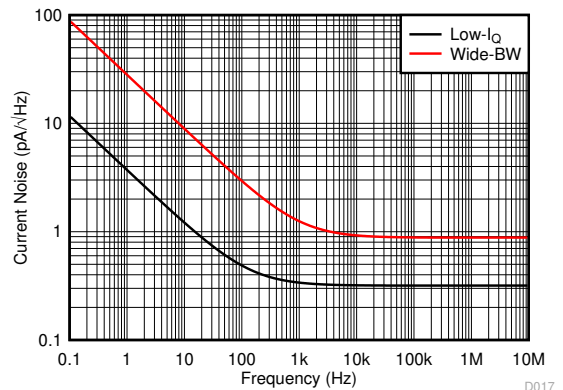
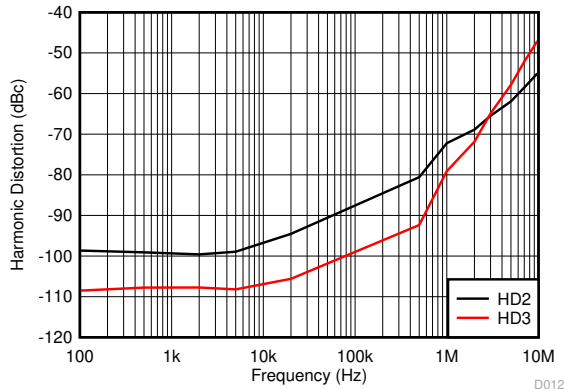
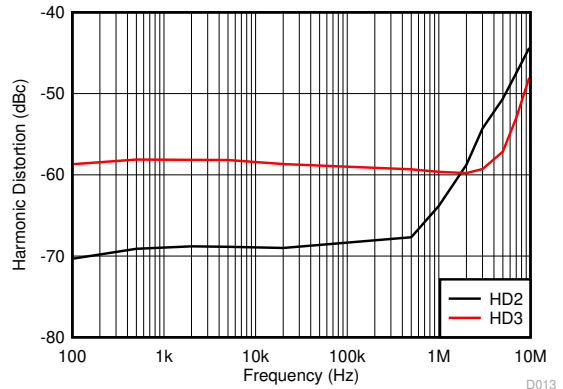

Figure 7-10. Current Noise Density vs Frequency



Wide-BW mode, $V_{IN} = 10\text{ V}_{PP}$, $R_L = 1\text{ k}\Omega$

Figure 7-11. Harmonic Distortion vs Frequency



Wide-BW mode, $V_{IN} = 10\text{ V}_{PP}$, $R_L = 100\ \Omega$

Figure 7-12. Harmonic Distortion vs Frequency

7.7 Typical Characteristics (continued)

At $T_A = 25^\circ\text{C}$, $V_S = \pm 15\text{ V}$, $R_S = 50\ \Omega$, and $R_L = 100\ \Omega$ (unless otherwise noted).

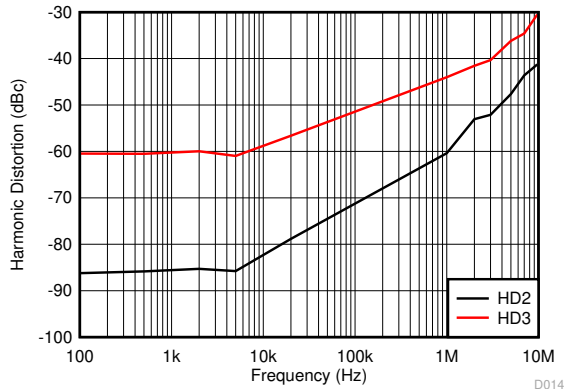

Low- I_Q mode, $V_{IN} = 10\text{ V}_{PP}$, $R_L = 1\text{ k}\Omega$

Figure 7-13. Harmonic Distortion vs Frequency

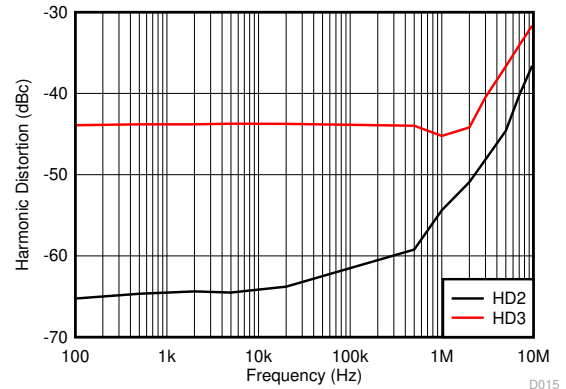

Low- I_Q mode, $V_{IN} = 10\text{ V}_{PP}$, $R_L = 100\ \Omega$

Figure 7-14. Harmonic Distortion vs Frequency

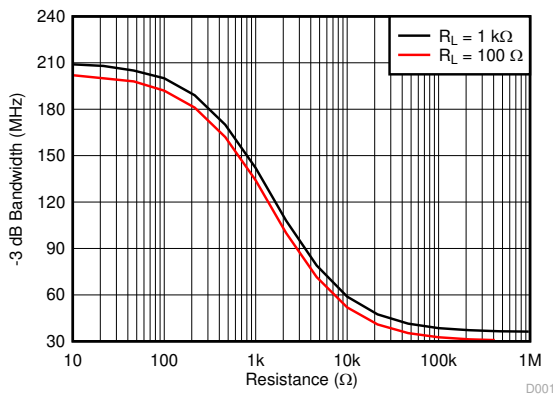

Figure 7-15. Small-Signal Bandwidth vs Bandwidth Adjustment Resistance

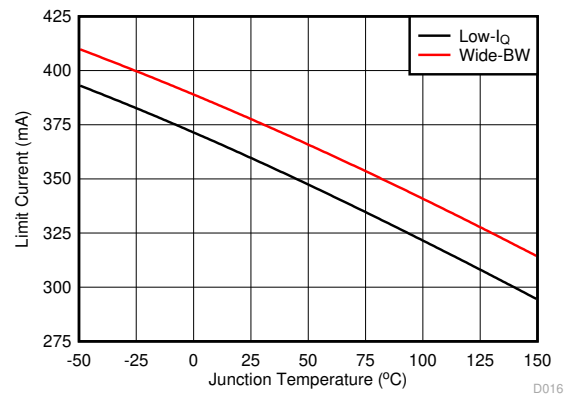
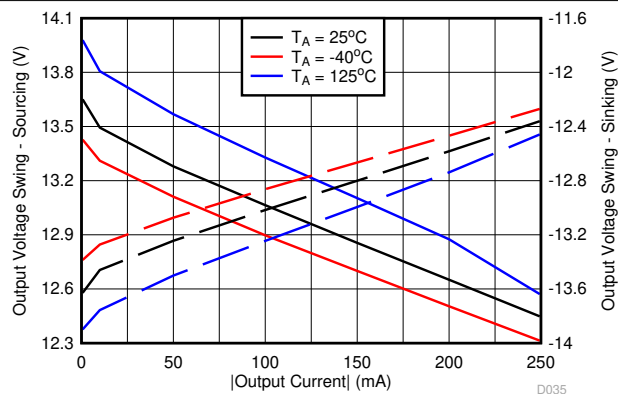
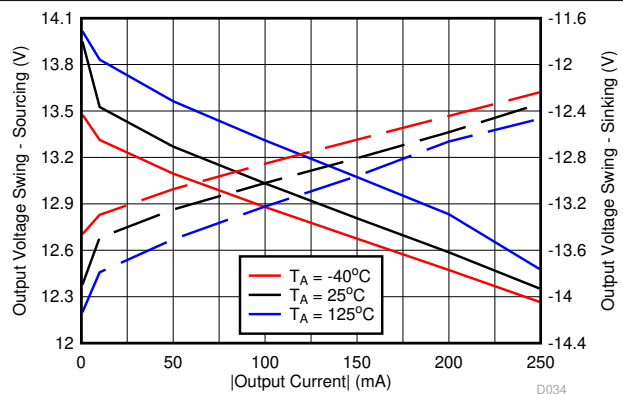

Figure 7-16. Short-Circuit Current vs Temperature



Wide-BW mode (solid lines indicate sourcing current, dashed lines indicate sinking current)

Figure 7-17. Output Voltage Swing vs Output Current



Low- I_Q mode (solid lines indicate sourcing current, dashed lines indicate sinking current)

Figure 7-18. Output Voltage Swing vs Output Current

7.7 Typical Characteristics (continued)

At $T_A = 25^\circ\text{C}$, $V_S = \pm 15\text{ V}$, $R_S = 50\ \Omega$, and $R_L = 100\ \Omega$ (unless otherwise noted).

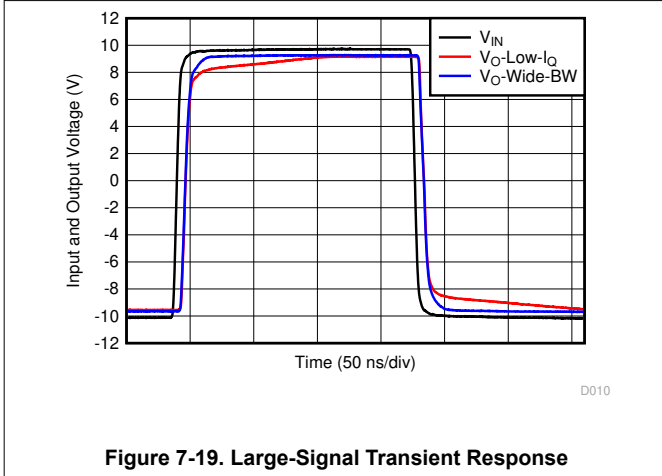

Figure 7-19. Large-Signal Transient Response

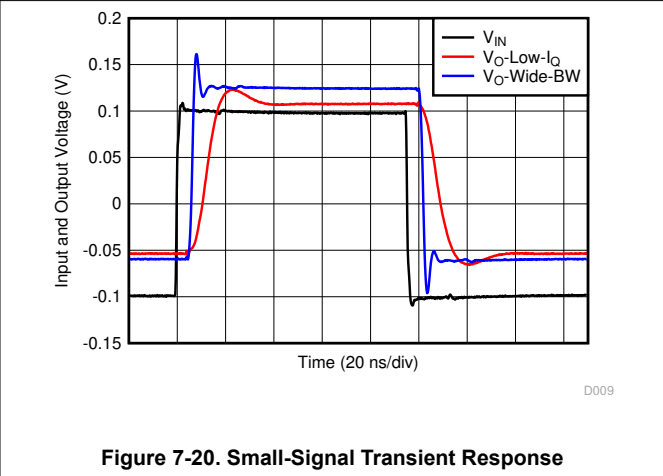

Figure 7-20. Small-Signal Transient Response

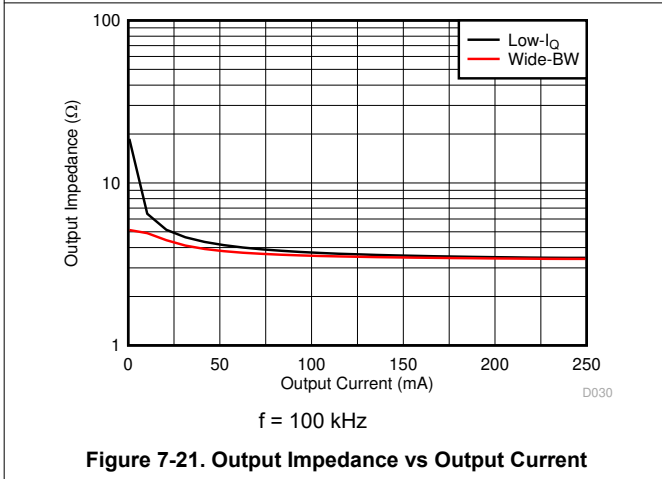

Figure 7-21. Output Impedance vs Output Current

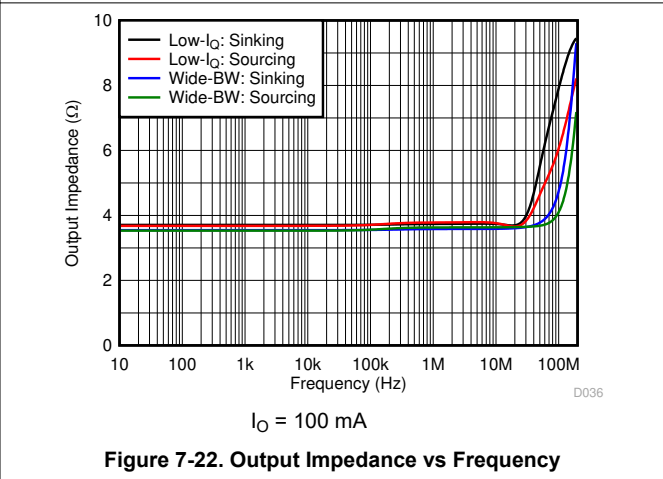

Figure 7-22. Output Impedance vs Frequency

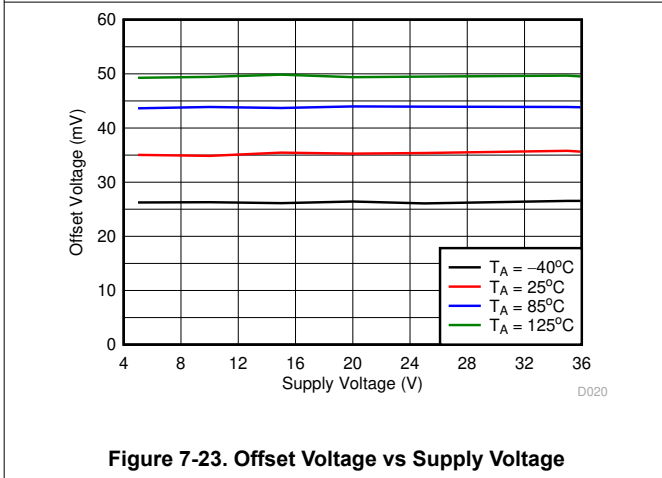

Figure 7-23. Offset Voltage vs Supply Voltage

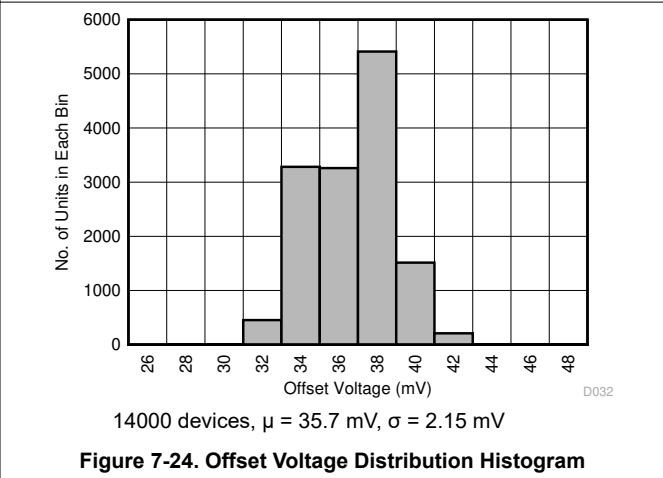

Figure 7-24. Offset Voltage Distribution Histogram

7.7 Typical Characteristics (continued)

At $T_A = 25^\circ\text{C}$, $V_S = \pm 15\text{ V}$, $R_S = 50\ \Omega$, and $R_L = 100\ \Omega$ (unless otherwise noted).

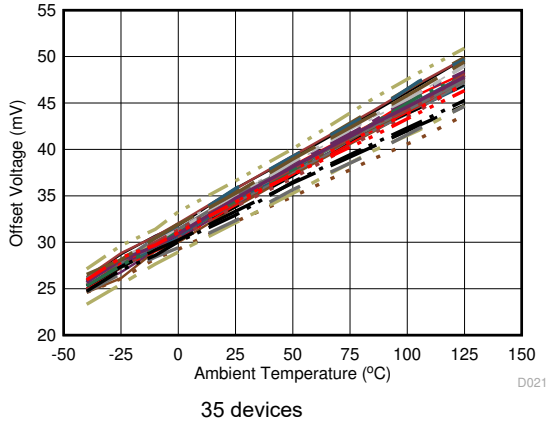

Figure 7-25. Offset Voltage vs Temperature

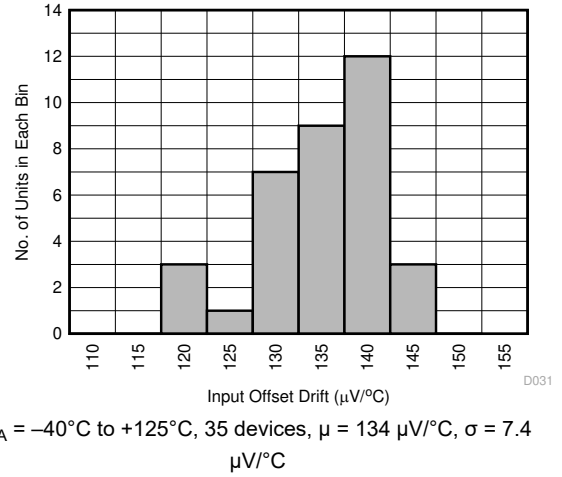

Figure 7-26. Offset Voltage Drift Distribution Histogram

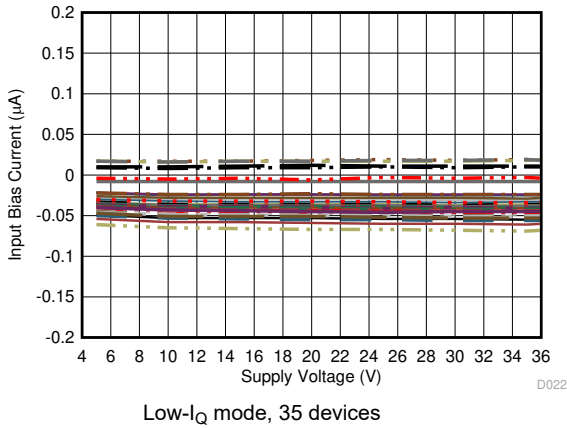

Figure 7-27. Input Bias Current vs Supply Voltage

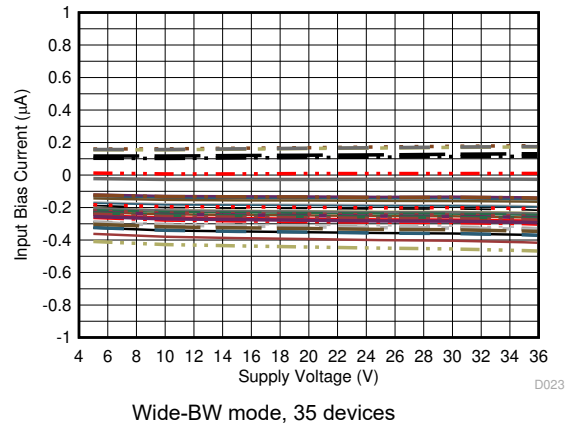

Figure 7-28. Input Bias Current vs Supply Voltage

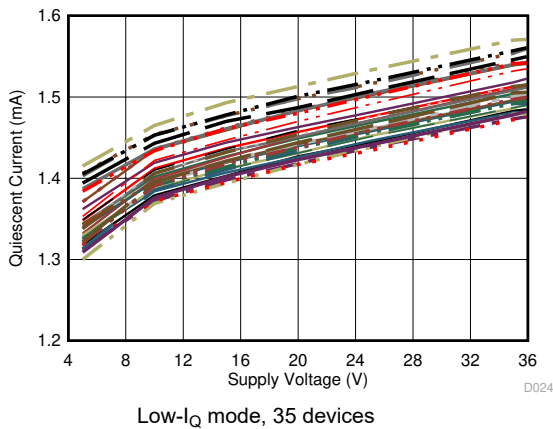

Figure 7-29. Quiescent Current vs Supply Voltage

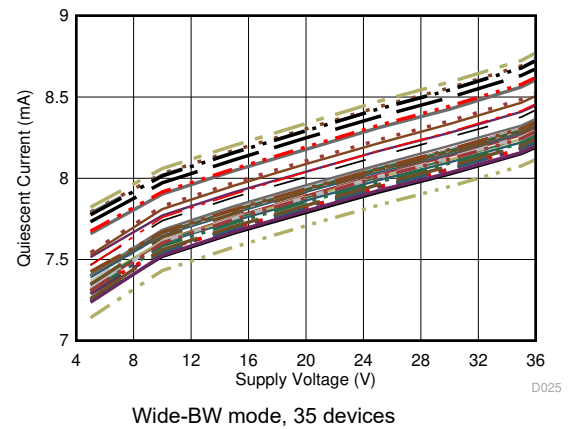

Figure 7-30. Quiescent Current vs Supply Voltage

7.7 Typical Characteristics (continued)

At $T_A = 25^\circ\text{C}$, $V_S = \pm 15\text{ V}$, $R_S = 50\ \Omega$, and $R_L = 100\ \Omega$ (unless otherwise noted).

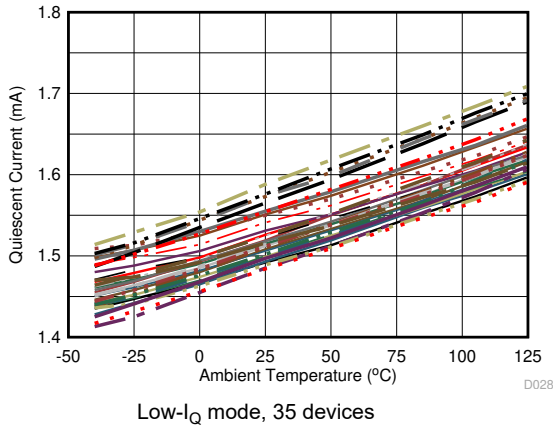

Figure 7-31. Quiescent Current vs Temperature

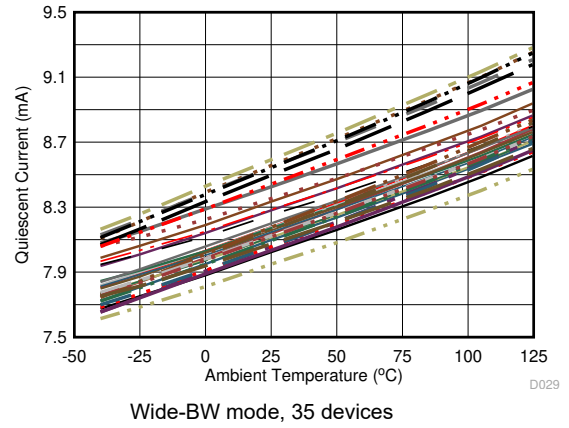

Figure 7-32. Quiescent Current vs Temperature

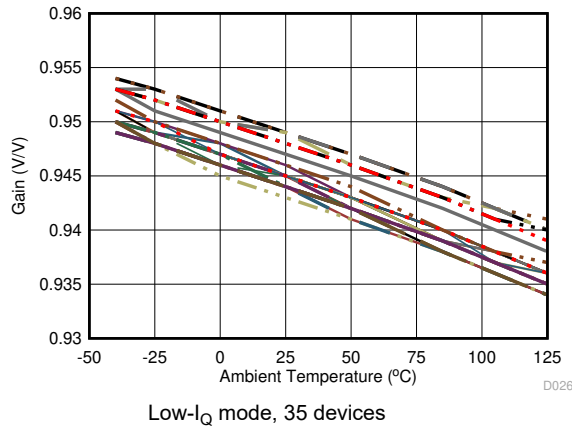

Figure 7-33. Buffer Gain vs Temperature

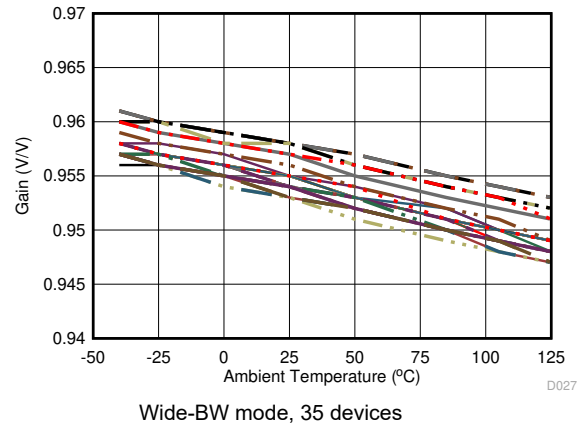

Figure 7-34. Buffer Gain vs Temperature

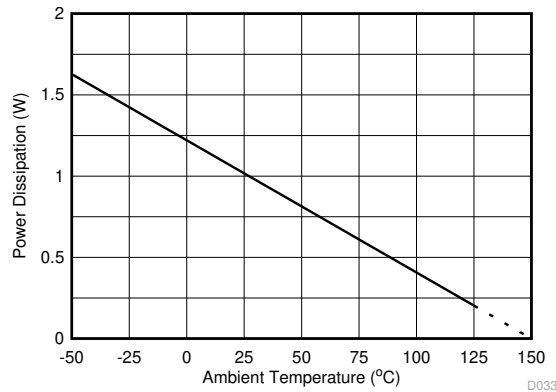

Figure 7-35. Maximum Power Dissipation vs Temperature

8 Detailed Description

8.1 Overview

The BUF634A device is a high-speed, unity-gain, open-loop buffer that can be used in a wide range of applications requiring large output current drive or large slew rates. The BUF634A can operate on power supplies ranging from 4.5 V to 36 V and includes an internal output current limiting feature and thermal shutdown, thereby making the device rugged and easy to use.

The bandwidth of the BUF634A can be adjusted by connecting a resistor between the V⁻ and BW pins. Its power scaling with bandwidth makes the device suitable for use in portable battery-powered applications. See the [Section 8.4.1](#) for a description of the relationship between bandwidth adjustment resistance and the device –3-dB bandwidth.

The BUF634A can be used in a composite loop (inside the feedback loop of op amps) to increase output current, eliminate thermal feedback, and improve capacitive load drive. See [Figure 9-7](#) for this circuit. Decoupling the high-power output current stage from the precision amplifier gives high precision performance by eliminating thermal effects on input offset of the composite circuit. With a large slew rate of 3750 V/μs, the BUF634A can quickly reproduce its input signal at its output without adding considerable delay when used in a composite loop. When used in a composite loop, the outer amplifier controls the circuit precision and distortion performance and the buffer augments the circuit output current drive capability.

See the [Section 8.2](#) for a simplified circuit diagram of the open-loop complementary follower design of the BUF634A.

8.2 Functional Block Diagram

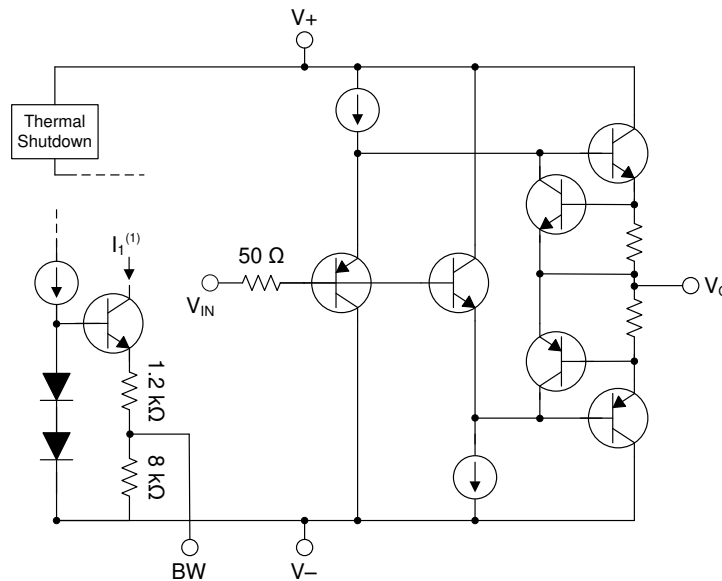

Stage currents are set by I_1 .

8.3 Feature Description

8.3.1 Output Current

The BUF634A can deliver up to ± 250 -mA continuous output current. Internal circuitry limits the output current to approximately ± 350 mA. Care must be taken to limit the output voltage swing for a given load resistance to avoid limiting the output current and degrading linearity; see [Figure 9-8](#). For many applications, however, the continuous output current is limited by thermal effects. The output voltage swing capability varies with junction temperature and output current; see [Figure 7-17](#) and [Figure 7-18](#). Care must be taken to operate the device below the maximum-recommended junction temperature in applications using this buffer in wide-bandwidth mode with a wide supply voltage and large output current to avoid permanent damage to the device.

8.3.2 Thermal Shutdown

Power dissipated in the BUF634A causes the junction temperature to rise. A thermal protection circuit in the BUF634A disables the output when the junction temperature reaches approximately 180°C . When the thermal protection is activated, the output stage is disabled and the output current is limited, allowing the device to cool. Quiescent current is approximately 12 mA during thermal shutdown. When the junction temperature cools to approximately 160°C , the output circuitry is again enabled. This process can cause the protection circuit to cycle on and off with a period ranging from a fraction of a second to several minutes or more, depending on package type, signal, load, and thermal environment.

The thermal protection circuit is designed to prevent damage during abnormal conditions. Any tendency to activate the thermal protection circuit during normal operation is a sign of an inadequate heat sink or excessive power dissipation for the package type.

8.3.3 ESD Protection

As shown in [Figure 8-1](#), all device pins are protected with internal ESD protection diodes to the power supplies. These diodes provide moderate protection to input overdrive voltages above the supplies. The protection diodes can typically support 10-mA continuous currents. Current limiting series resistors must be added at the inputs if common-mode voltages higher than the supply voltages are possible. Keep these resistor values as low as possible because using high values degrades noise performance and frequency response. V_{IN} is a non fail-safe pin. Ensure $V+$ and $V-$ are powered up before applying a signal to the V_{IN} pin. Failure to do so results in current flowing through the ESD diode. Restrict any current flowing through the ESD diodes to less than 10 mA.

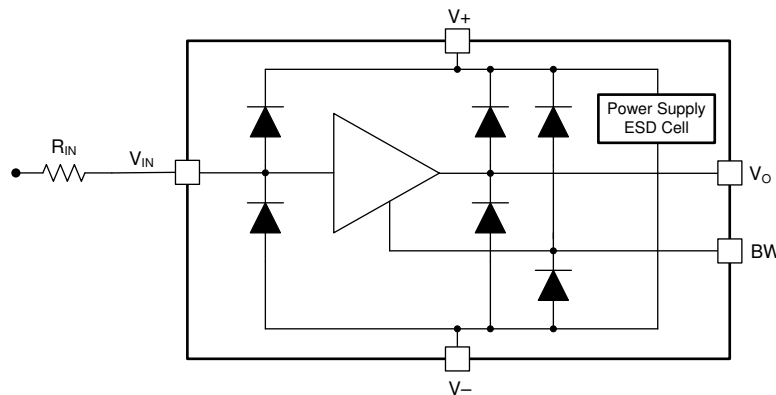

Figure 8-1. Internal ESD Protection

8.4 Device Functional Modes

8.4.1 Adjustable Bandwidth

The BUF634A –3-dB bandwidth can be adjusted from 35 MHz to 210 MHz for a 1-k Ω load resistance, as shown in Figure 8-2, by connecting a resistor between the V– and BW pins. The bandwidth is set to 210 MHz with the BW pin connected to V– and to 35 MHz with the BW pin left floating. The –3-dB bandwidth also changes with the value of the load resistance for a given bandwidth adjustment resistance. The device quiescent current varies from 1.5 mA (typical) to 8.5 mA (typical) with variation in bandwidth from 35 MHz to 210 MHz, respectively.

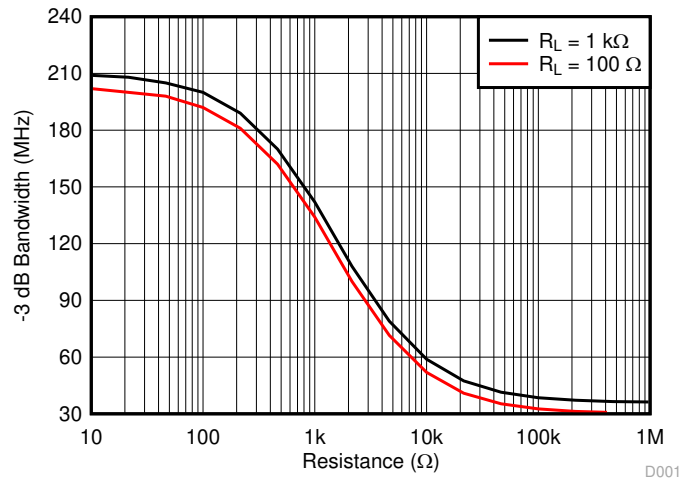

Figure 8-2. Small-Signal Bandwidth versus Bandwidth Adjustment Resistance

9 Application and Implementation

Note

Information in the following applications sections is not part of the TI component specification, and TI does not warrant its accuracy or completeness. TI's customers are responsible for determining suitability of components for their purposes. Customers should validate and test their design implementation to confirm system functionality.

9.1 Application Information

Figure 9-1 shows the BUF634A connected as an open-loop buffer. The source impedance and optional input resistor, R_S , influence the frequency response; see Figure 7-3. Bypass the power supplies with capacitors connected close to the device pins. Capacitor values as low as 0.1 μF assure stable operation in most applications, but high output current and fast output slewing can demand large current transients from the power supplies, requiring the use of solid tantalum 10- μF capacitors. High-frequency, open-loop applications benefit from special bypassing and layout considerations. See the Section 9.1.1 for more information. If the BUF634A input is left floating, the device output can swing to either of the supplies based on the input bias current polarity.

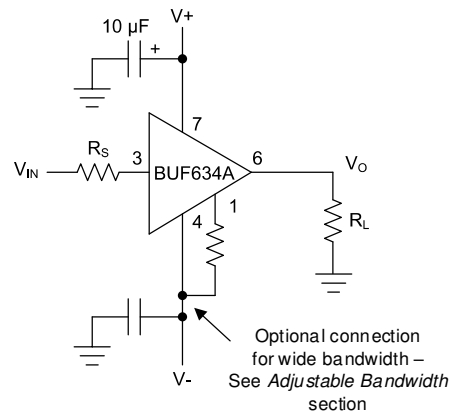

Figure 9-1. Buffer Connections

9.1.1 High-Frequency Applications

The excellent bandwidth and fast slew rate of the BUF634A are useful in a variety of high-frequency, open-loop applications. When operated in an open-loop application, printed circuit board (PCB) layout and bypassing techniques can affect dynamic performance. Figure 9-2 through Figure 9-6 illustrate various application circuit examples for the BUF634A.

For best results, use a ground-plane-type circuit board layout and bypass the power supplies with 0.1- μF ceramic chip capacitors at the device pins in parallel with solid tantalum 10- μF capacitors. Source resistance affects high-frequency peaking, step-response overshoot, and ringing. Best response is usually achieved with a series input resistor of 25 Ω to 200 Ω , depending on the signal source. Response with some loads (especially capacitive) can be improved with a resistor of 10 Ω to 150 Ω in series with the output. When driving multiple device under test (DUT) inputs in automatic test equipment (ATE) testers (large capacitive load), as illustrated in Figure 9-3, place an isolation resistor at the output of the BUF634A for adequate phase margin and stability.

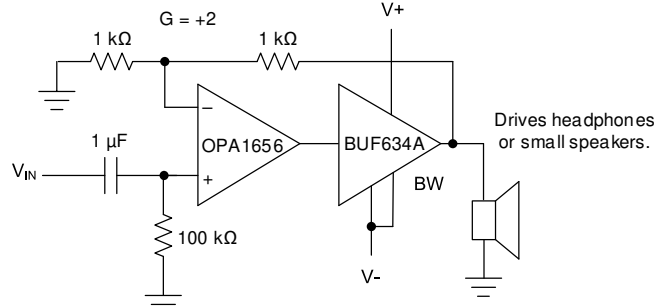

Figure 9-2. High-Performance Headphone Driver

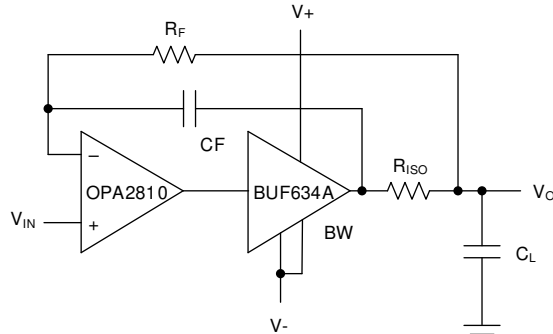

Figure 9-3. ATE and Test Pin Driver

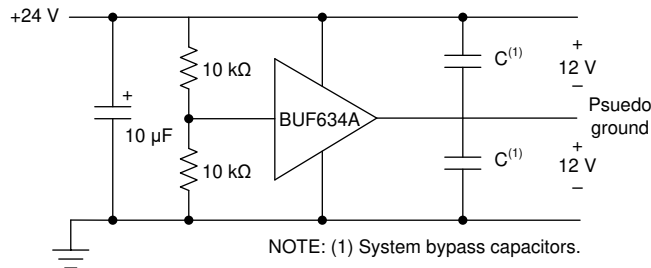

Figure 9-4. Pseudo-Ground Driver

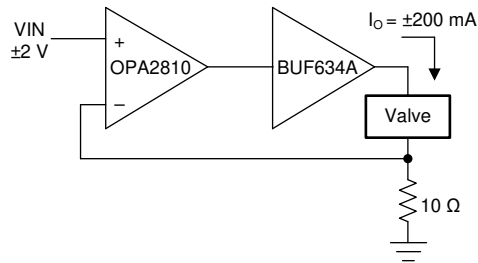

Figure 9-5. Current-Output Valve Driver

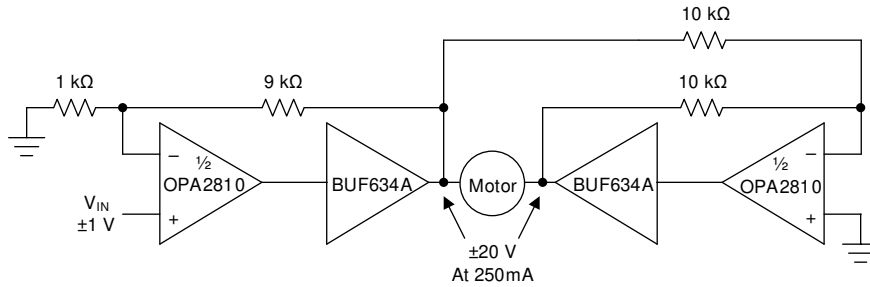
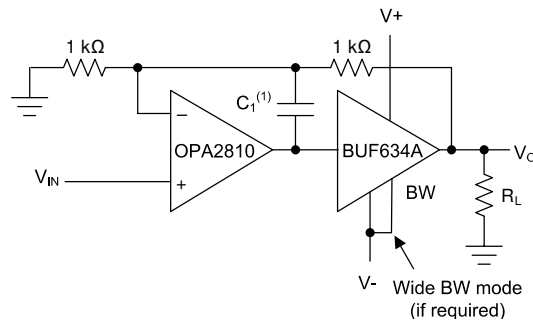

Figure 9-6. Bridge-Connected Motor Driver

9.2 Typical Application

The BUF634A device can be connected inside the feedback loop, as shown in [Figure 9-7](#), of most op amps to increase output current. When connected inside the feedback loop, the offset voltage of the BUF634A and other errors are corrected by the open-loop gain and feedback of the op amp.



C_1 is not required for most common op amps. Use C_1 with unity-gain stable, high-speed op amps.

Figure 9-7. Boosting Op Amp Output Current

9.2.1 Design Requirements

- Boost the output current of an [OPA2810](#)
- Operate from ± 12 -V power supplies
- Operate from -40°C to $+125^\circ\text{C}$
- Gain = 2 V/V
- Output current = ± 250 mA
- Bandwidth greater than 100 kHz

9.2.2 Detailed Design Procedure

To assure that the composite amplifier remains stable, the phase shift of the BUF634A must remain small throughout the loop gain of the circuit. For a $G = +1$ op-amp circuit, the BUF634A must contribute little additional phase shift (approximately 20° or less) at the unity-gain frequency of the op amp. Phase shift is affected by various operating conditions that can affect the stability of the op amp.

For the circuit in Figure 9-7, most general-purpose or precision op amps remain unity-gain stable with the BUF634A connected inside the feedback loop. Large capacitive loads may require the BUF634A to be connected for wide bandwidth for stable operation. High-speed or fast-settling op amps generally require wide-bandwidth mode to remain stable and to assure good dynamic performance. Check for oscillations or excessive ringing on signal pulses with the intended load and worst-case conditions that affect phase response of the buffer to determine stability with an op amp. Connect the circuit as shown in Figure 9-7. Choose resistors to provide a voltage gain of 2 V/V. Select the feedback resistor to be 1 k Ω . Choose the input resistor to be 1 k Ω and C_1 to be 10 pF. Figure 9-8 and Figure 9-9 illustrate the THD+N plots for the BUF634A used with the OPA2810 in a gain of

2-V/V composite loop. The THD+N performance is superior in a composite loop when compared with a standalone BUF634A because of the negative feedback and open-loop gain of the OPA2810. In Figure 9-8, the signal distortion degrades for large output voltages with 16- Ω and 32- Ω loads because of the device internal short-circuit protection.

9.2.3 Application Curves

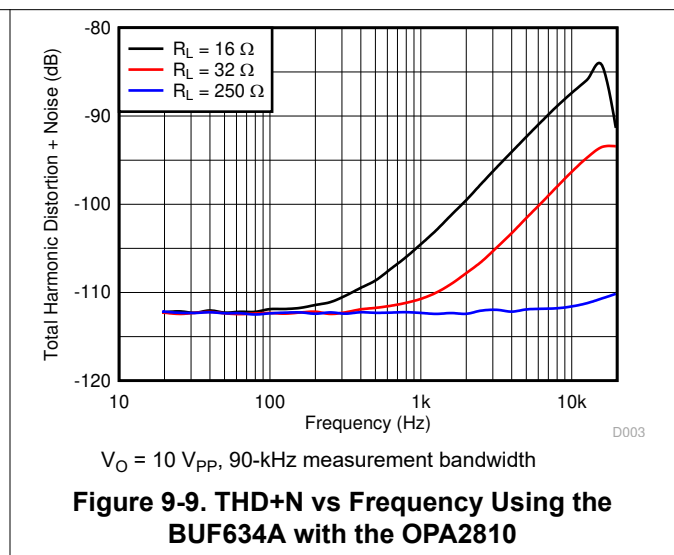
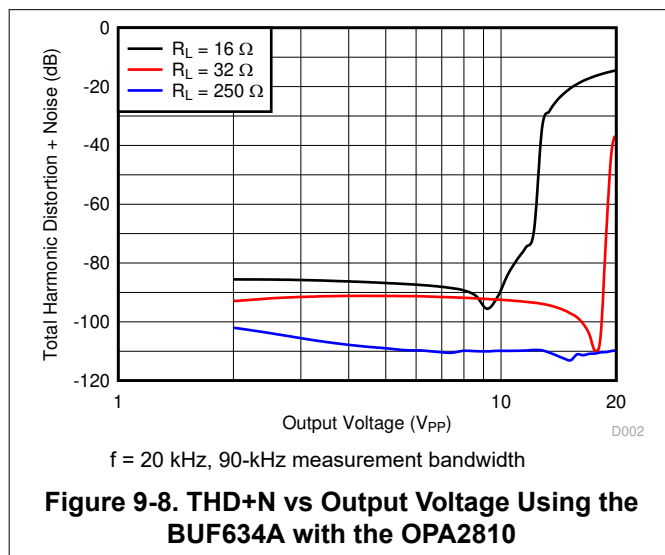

10 Power Supply Recommendations

The BUF634A is intended for operation on supplies ranging from 4.5 V to 36 V (± 2.25 V to ± 18 V). At low power-supply conditions, such as ± 2.25 V, the output swing may be limited. See the output voltage range specifications in the [Electrical Characteristics](#) tables for additional information. The BUF634A can be operated on single-sided supplies, split, and balanced bipolar supplies or unbalanced bipolar supplies. Operating from a single supply can have numerous advantages. With the negative supply at ground, the DC errors resulting from the $-PSRR$ term can be minimized. Minimize the distance (< 0.1 in.) from the power-supply pins to high-frequency, 0.1- μ F decoupling capacitors. A larger capacitor (10 μ F typical) is used along with a high-frequency, 0.1- μ F supply-decoupling capacitor at the device supply pins. For single-supply operation, only the positive supply has these capacitors. When a split-supply is used, use these capacitors from each supply to ground. If necessary, place the larger capacitors further from the device and share these capacitors among several devices in the same area of the PCB.

10.1 Power Dissipation and Thermal Considerations

The BUF634A includes automatic thermal shutoff protection. This protection circuitry shuts down the amplifier if the junction temperature exceeds approximately 180°C. When the junction temperature decreases to approximately 160°C, the buffer turns on again. The package and the PCB dictate the thermal characteristics of the device. Maximum power dissipation for a particular package is calculated using the following formula.

$$P_{Dmax} = \frac{T_{max} - T_A}{\theta_{JA}} \quad (1)$$

where

- P_{Dmax} is the maximum power dissipation in the amplifier (W).
- T_{max} is the absolute maximum junction temperature (°C).
- T_A is the ambient temperature (°C).
- $\theta_{JA} = \theta_{JC} + \theta_{CA}$
- θ_{JC} is the thermal coefficient from the silicon junctions to the case (°C/W).
- θ_{CA} is the thermal coefficient from the case to ambient air (°C/W).

The thermal coefficient for the thermal pad integrated circuit packages are substantially improved over the traditional SOIC package. The data for the thermal pad packages assume a board layout that follows the thermal pad package layout guidelines referenced above and detailed in the [PowerPAD™ Thermally Enhanced Package application report](#). If the thermal package integrated circuit package is not soldered to the PCB, the thermal impedance increases substantially and may cause serious heat and performance issues.

When determining whether or not the device satisfies the maximum power dissipation requirement, make sure to consider not only quiescent power dissipation, but dynamic power dissipation. Often times, this dissipation is difficult to quantify because the signal pattern is inconsistent, but an estimate of the RMS power dissipation provides visibility into a possible problem.

11 Layout

11.1 Layout Guidelines

11.1.1 SOIC Layout Guidelines (D Package Without a Thermal Pad)

For best operational performance of the device, use good PCB layout practices, including:

- Noise can propagate into analog circuitry through the power pins of the circuit. Bypass capacitors are used to reduce the coupled noise by providing low-impedance power sources local to the analog circuitry.
 - Connect low-ESR, 0.1- μ F ceramic bypass capacitors between each supply pin and ground, placed as close to the device as possible. A single bypass capacitor from V+ to ground is applicable for single-supply applications.
- Separate grounding for analog and digital portions of circuitry is one of the simplest and most effective methods of noise suppression. One or more layers on multilayer PCBs are usually devoted to ground planes. A ground plane helps distribute heat and reduces electromagnetic interference (EMI) noise pickup. Make sure to physically separate digital and analog grounds, paying attention to the flow of the ground current.
- In order to reduce parasitic coupling, run the input traces as far away from the supply or output traces as possible. If these traces cannot be kept separate, crossing the sensitive trace perpendicular is much better as opposed to in parallel with the noisy trace.
- Place the external components as close to the device as possible, as illustrated in [Figure 11-2](#).
- Keep the length of input traces as short as possible. Always remember that the input traces are the most sensitive part of the circuit.
- Cleaning the PCB following board assembly is recommended for best performance.
- Any precision integrated circuit can experience performance shifts resulting from moisture ingress into the plastic package. Following any aqueous PCB cleaning process, baking the PCB assembly is recommended to remove moisture introduced into the device packaging during the cleaning process. A low-temperature, post-cleaning bake at 85°C for 30 minutes is sufficient for most circumstances.

The SOIC-8 surface-mount package is excellent for applications requiring high output current with low average power dissipation. To achieve the best possible thermal performance with the SOIC-8 package, solder the device directly to a circuit board. Sockets degrade thermal performance because much of the heat is dissipated by conduction through the package pins. Use wide circuit board traces on all device pins, including pins that are not connected. For more information on designing the circuit board, see the [BUF634AD Evaluation module user's guide](#).

11.1.2 HSOIC Layout Guidelines (DDA Package With a Thermal Pad)

Figure 11-1 shows the DDA package top-side etch and via pattern.

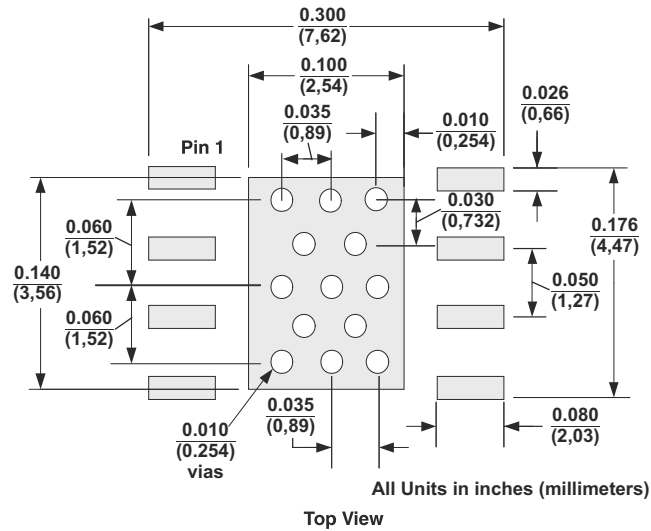

Figure 11-1. DDA Thermal Pad Integrated Circuit Package PCB Etch and Via Pattern

1. Use an etch for the leads and the thermal pad.
2. Place 13 vias in the thermal pad area. These vias must be 0.01 inch (0.254 mm) in diameter. Keep the vias small so that solder wicking through the vias is not a problem during reflow.
3. Additional vias may be placed anywhere along the thermal plane outside of the thermal pad area, and help dissipate the heat generated by the BUF634A. These additional vias may be larger than the 0.01-inch (0.254 mm) diameter vias directly under the thermal pad because they are not in the area that requires soldering. As a result, wicking is not a problem.
4. The thermal pad is internally connected with V-. Therefore, always short the thermal pad to the same potential as V- externally as well.
5. Connect all vias used under the thermal pad to remove heat to the V- plane.
6. When connecting these vias to the V- plane, do not use the typical web or spoke connection methodology. Web and spoke connections have a high thermal resistance that slows the heat transfer during soldering. The vias under the BUF634A thermal pad must connect to the internal thermal plane or thermal pour with a complete connection around the entire circumference of the plated-through hole.
7. The top-side solder mask must leave the pins of the package and the thermal pad area with the 13 vias exposed.
8. Apply solder paste to the exposed thermal pad area and all of the device pins.
9. With these preparatory steps in place, the device is placed in position and run through the solder reflow operation as any standard surface-mount component.

11.2 Layout Example

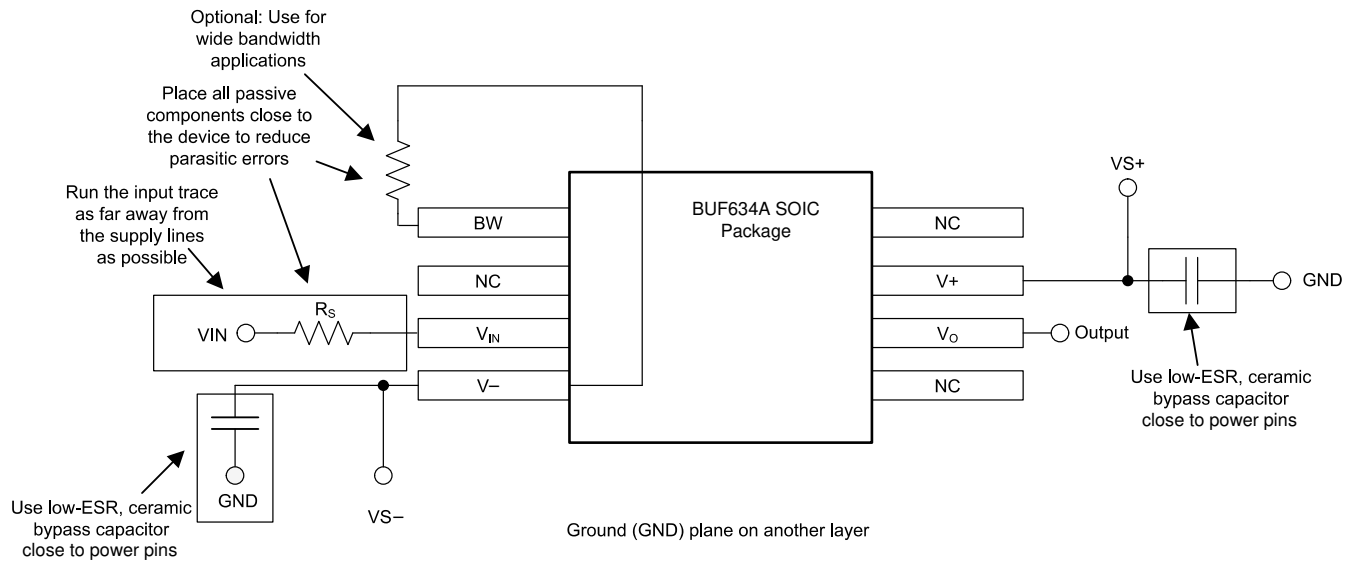

Figure 11-2. BUF634A Layout Example (SOIC)

12 Device and Documentation Support

12.1 Device Support

12.1.1 Third-Party Products Disclaimer

TI'S PUBLICATION OF INFORMATION REGARDING THIRD-PARTY PRODUCTS OR SERVICES DOES NOT CONSTITUTE AN ENDORSEMENT REGARDING THE SUITABILITY OF SUCH PRODUCTS OR SERVICES OR A WARRANTY, REPRESENTATION OR ENDORSEMENT OF SUCH PRODUCTS OR SERVICES, EITHER ALONE OR IN COMBINATION WITH ANY TI PRODUCT OR SERVICE.

12.1.2 Development Support

12.1.2.1 TINA-TI™ (Free Software Download)

TINA™ is a simple, powerful, and easy-to-use circuit simulation program based on a SPICE engine. TINA-TI is a free, fully-functional version of the TINA software, and is preloaded with a library of macromodels in addition to a range of both passive and active models. TINA-TI provides all the conventional DC, transient, and frequency domain analysis of SPICE, as well as additional design capabilities.

Available as a [free download](#) from the Analog eLab Design Center, TINA-TI offers extensive post-processing capability that allows users to format results in a variety of ways. Virtual instruments offer the ability to select input waveforms and probe circuit nodes, voltages, and waveforms, creating a dynamic quick-start tool.

Note

These files require that either the TINA software (from DesignSoft™) or TINA-TI software be installed. Download the free TINA-TI software from the [TINA-TI folder](#).

12.1.2.2 TI Precision Designs

The BUF634A is featured in several TI Precision Designs, available online at www.ti.com. TI Precision Designs are analog solutions created by TI's precision analog applications experts and offer the theory of operation, component selection, simulation, complete PCB schematic and layout, bill of materials, and measured performance of many useful circuits.

12.2 Documentation Support

12.2.1 Related Documentation

For related documentation see the following:

- Texas Instruments, [OPA2810 Dual-channel, 27-V, Rail-to-Rail Input/Output FET-Input Operational Amplifier data sheet](#)
- Texas Instruments, [BUF634AD Evaluation Module user's guide](#)
- Texas Instruments, [Combining An Amplifier with the BUF634 application note](#)
- Texas Instruments, [Add Current Limit to the BUF634 application note](#)
- Texas Instruments, [Power Amplifier Stress and Power Handling Limitations application note](#)
- Texas Instruments, [Shelf-Life Evaluation of Lead-Free Component Finishes application report](#)

12.3 Receiving Notification of Documentation Updates

To receive notification of documentation updates, navigate to the device product folder on ti.com. In the upper right corner, click on *Alert me* to register and receive a weekly digest of any product information that has changed. For change details, review the revision history included in any revised document.

12.4 Support Resources

TI E2E™ [support forums](#) are an engineer's go-to source for fast, verified answers and design help — straight from the experts. Search existing answers or ask your own question to get the quick design help you need.

Linked content is provided "AS IS" by the respective contributors. They do not constitute TI specifications and do not necessarily reflect TI's views; see TI's [Terms of Use](#).

12.5 Trademarks

TINA-TI™, TINA™, and TI E2E™ are trademarks of Texas Instruments.
DesignSoft™ is a trademark of DesignSoft, Inc.
All trademarks are the property of their respective owners.

12.6 Electrostatic Discharge Caution



This integrated circuit can be damaged by ESD. Texas Instruments recommends that all integrated circuits be handled with appropriate precautions. Failure to observe proper handling and installation procedures can cause damage.

ESD damage can range from subtle performance degradation to complete device failure. Precision integrated circuits may be more susceptible to damage because very small parametric changes could cause the device not to meet its published specifications.

12.7 Glossary

[TI Glossary](#) This glossary lists and explains terms, acronyms, and definitions.

13 Mechanical, Packaging, and Orderable Information

The following pages include mechanical, packaging, and orderable information. This information is the most current data available for the designated devices. This data is subject to change without notice and revision of this document. For browser-based versions of this data sheet, refer to the left-hand navigation.

EXAMPLE BOARD LAYOUT

DRB0008B

VSON - 1 mm max height

PLASTIC SMALL OUTLINE - NO LEAD

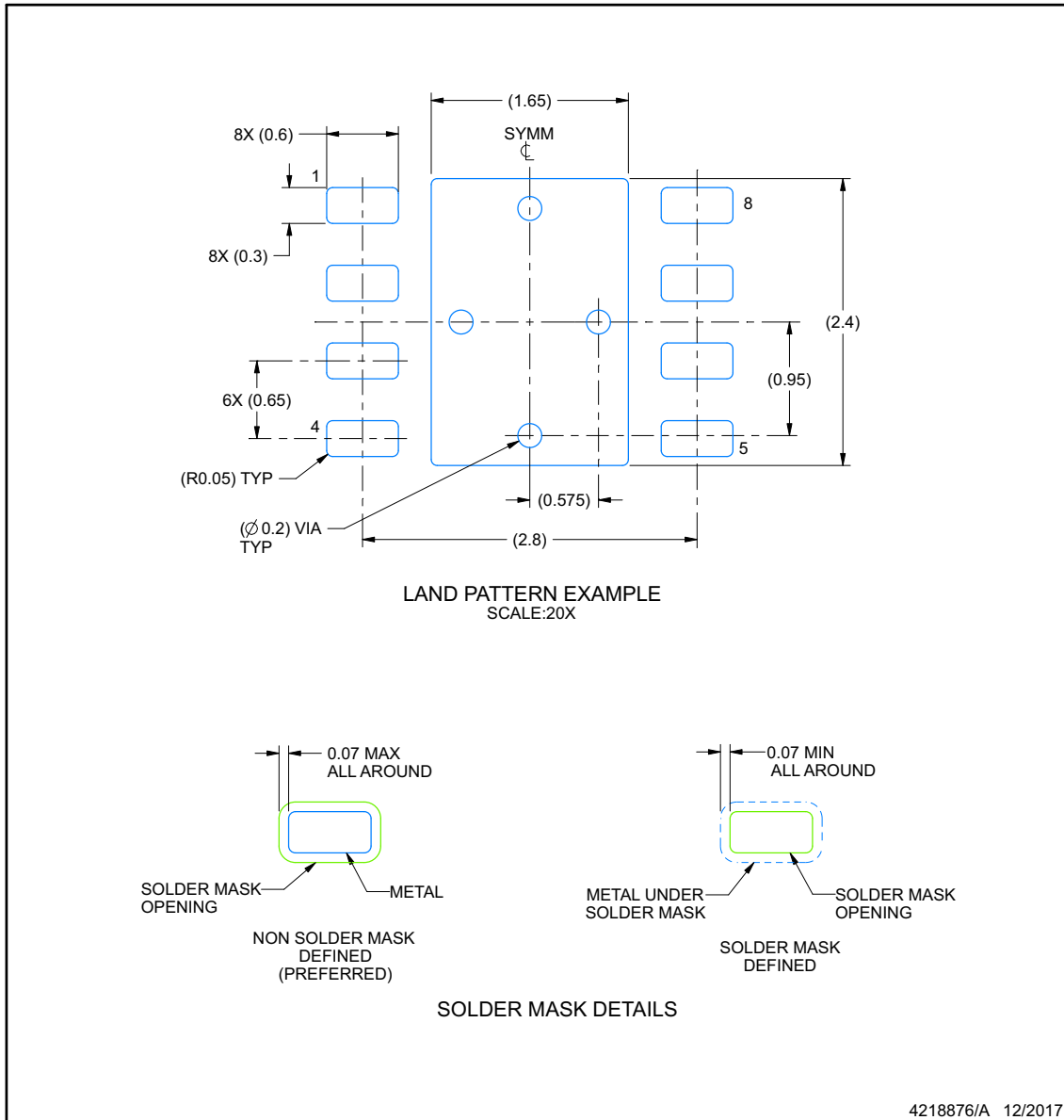

NOTES: (continued)

- This package is designed to be soldered to a thermal pad on the board. For more information, see Texas Instruments literature number SLUA271 (www.ti.com/lit/slua271).
- Vias are optional depending on application, refer to device data sheet. If any vias are implemented, refer to their locations shown on this view. It is recommended that vias under paste be filled, plugged or tented.

EXAMPLE STENCIL DESIGN

DRB0008B

VSON - 1 mm max height

PLASTIC SMALL OUTLINE - NO LEAD

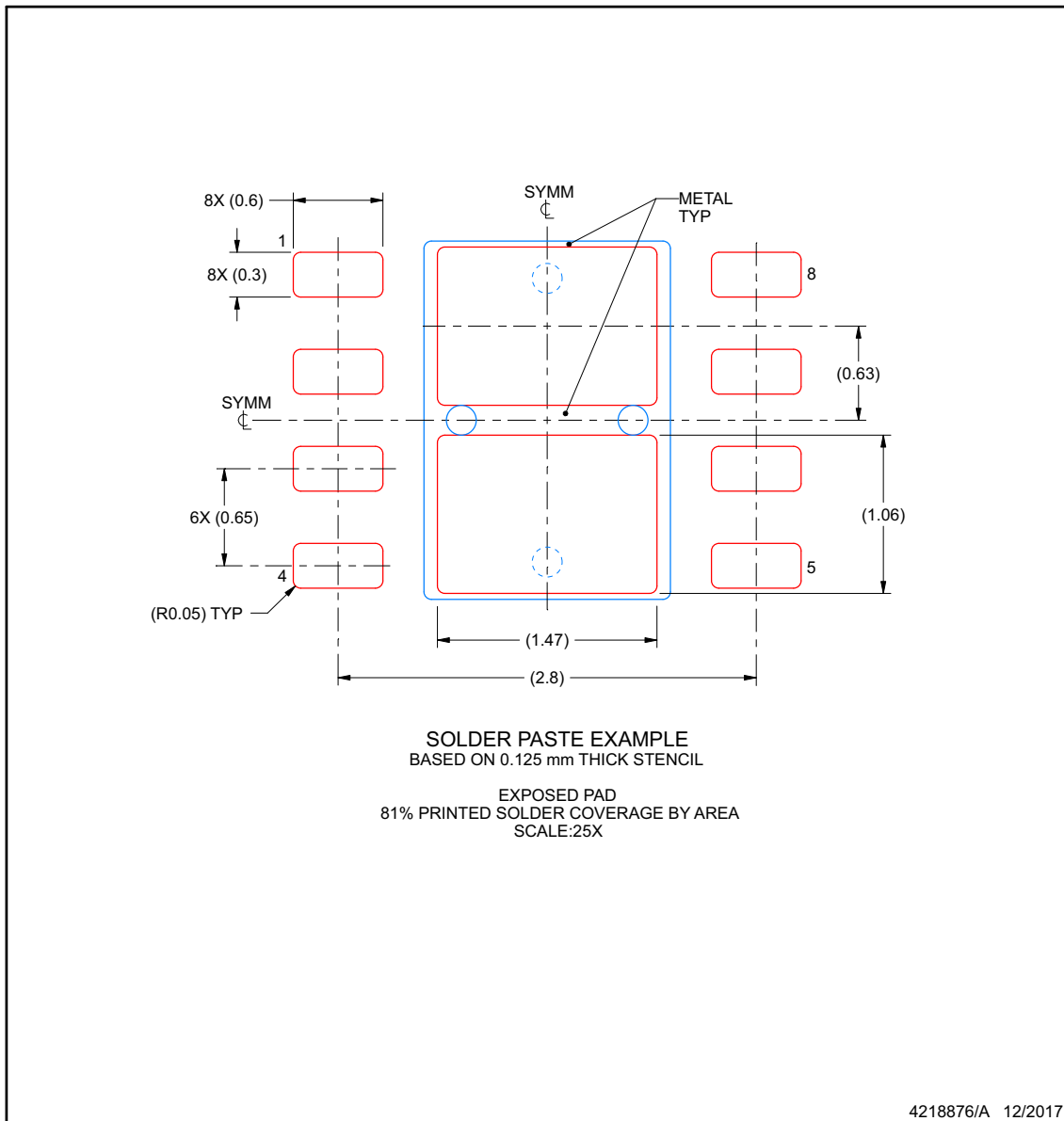

NOTES: (continued)

6. Laser cutting apertures with trapezoidal walls and rounded corners may offer better paste release. IPC-7525 may have alternate design recommendations.

PACKAGING INFORMATION

| Orderable Device | Status (1) | Package Type | Package Drawing | Pins | Package Qty | Eco Plan (2) | Lead finish/ Ball material (6) | MSL Peak Temp (3) | Op Temp (°C) | Device Marking (4/5) | Samples |
|------------------|---------------|--------------|-----------------|------|-------------|-----------------|--------------------------------------|----------------------|--------------|-------------------------|-------------------------|
| BUF634AIDDR | ACTIVE | SO PowerPAD | DDA | 8 | 2500 | RoHS & Green | NIPDAUAG | Level-2-260C-1 YEAR | -40 to 125 | BF634A | Samples |
| BUF634AIDR | ACTIVE | SOIC | D | 8 | 2500 | RoHS & Green | NIPDAU | Level-2-260C-1 YEAR | -40 to 125 | BF634A | Samples |
| BUF634AIDRBR | ACTIVE | SON | DRB | 8 | 3000 | RoHS & Green | NIPDAU | Level-1-260C-UNLIM | -40 to 125 | B634A | Samples |

(1) The marketing status values are defined as follows:

ACTIVE: Product device recommended for new designs.

LIFEBUY: TI has announced that the device will be discontinued, and a lifetime-buy period is in effect.

NRND: Not recommended for new designs. Device is in production to support existing customers, but TI does not recommend using this part in a new design.

PREVIEW: Device has been announced but is not in production. Samples may or may not be available.

OBSOLETE: TI has discontinued the production of the device.

(2) **RoHS:** TI defines "RoHS" to mean semiconductor products that are compliant with the current EU RoHS requirements for all 10 RoHS substances, including the requirement that RoHS substance do not exceed 0.1% by weight in homogeneous materials. Where designed to be soldered at high temperatures, "RoHS" products are suitable for use in specified lead-free processes. TI may reference these types of products as "Pb-Free".

RoHS Exempt: TI defines "RoHS Exempt" to mean products that contain lead but are compliant with EU RoHS pursuant to a specific EU RoHS exemption.

Green: TI defines "Green" to mean the content of Chlorine (Cl) and Bromine (Br) based flame retardants meet JS709B low halogen requirements of <=1000ppm threshold. Antimony trioxide based flame retardants must also meet the <=1000ppm threshold requirement.

(3) MSL, Peak Temp. - The Moisture Sensitivity Level rating according to the JEDEC industry standard classifications, and peak solder temperature.

(4) There may be additional marking, which relates to the logo, the lot trace code information, or the environmental category on the device.

(5) Multiple Device Markings will be inside parentheses. Only one Device Marking contained in parentheses and separated by a "~" will appear on a device. If a line is indented then it is a continuation of the previous line and the two combined represent the entire Device Marking for that device.

(6) Lead finish/Ball material - Orderable Devices may have multiple material finish options. Finish options are separated by a vertical ruled line. Lead finish/Ball material values may wrap to two lines if the finish value exceeds the maximum column width.

Important Information and Disclaimer:The information provided on this page represents TI's knowledge and belief as of the date that it is provided. TI bases its knowledge and belief on information provided by third parties, and makes no representation or warranty as to the accuracy of such information. Efforts are underway to better integrate information from third parties. TI has taken and continues to take reasonable steps to provide representative and accurate information but may not have conducted destructive testing or chemical analysis on incoming materials and chemicals. TI and TI suppliers consider certain information to be proprietary, and thus CAS numbers and other limited information may not be available for release.

In no event shall TI's liability arising out of such information exceed the total purchase price of the TI part(s) at issue in this document sold by TI to Customer on an annual basis.

TAPE AND REEL INFORMATION

QUADRANT ASSIGNMENTS FOR PIN 1 ORIENTATION IN TAPE

*All dimensions are nominal

| Device | Package Type | Package Drawing | Pins | SPQ | Reel Diameter (mm) | Reel Width W1 (mm) | A0 (mm) | B0 (mm) | K0 (mm) | P1 (mm) | W (mm) | Pin1 Quadrant |
|--------------|--------------|-----------------|------|------|--------------------|--------------------|---------|---------|---------|---------|--------|---------------|
| BUF634AIDDAR | SO PowerPAD | DDA | 8 | 2500 | 330.0 | 12.8 | 6.4 | 5.2 | 2.1 | 8.0 | 12.0 | Q1 |
| BUF634AIDR | SOIC | D | 8 | 2500 | 330.0 | 12.4 | 6.4 | 5.2 | 2.1 | 8.0 | 12.0 | Q1 |
| BUF634AIDRBR | SON | DRB | 8 | 3000 | 330.0 | 12.4 | 3.3 | 3.3 | 1.1 | 8.0 | 12.0 | Q2 |

TAPE AND REEL BOX DIMENSIONS

*All dimensions are nominal

| Device | Package Type | Package Drawing | Pins | SPQ | Length (mm) | Width (mm) | Height (mm) |
|--------------|--------------|-----------------|------|------|-------------|------------|-------------|
| BUF634AIDDAR | SO PowerPAD | DDA | 8 | 2500 | 366.0 | 364.0 | 50.0 |
| BUF634AIDR | SOIC | D | 8 | 2500 | 356.0 | 356.0 | 35.0 |
| BUF634AIDRBR | SON | DRB | 8 | 3000 | 367.0 | 367.0 | 35.0 |

DRB 8

GENERIC PACKAGE VIEW

VSON - 1 mm max height

PLASTIC SMALL OUTLINE - NO LEAD



Images above are just a representation of the package family, actual package may vary.
Refer to the product data sheet for package details.

4203482/L

EXAMPLE BOARD LAYOUT

DRB0008B

VSON - 1 mm max height

PLASTIC SMALL OUTLINE - NO LEAD



LAND PATTERN EXAMPLE
SCALE:20X



SOLDER MASK DETAILS

4218876/A 12/2017

NOTES: (continued)

4. This package is designed to be soldered to a thermal pad on the board. For more information, see Texas Instruments literature number SLUA271 (www.ti.com/lit/slue271).
5. Vias are optional depending on application, refer to device data sheet. If any vias are implemented, refer to their locations shown on this view. It is recommended that vias under paste be filled, plugged or tented.

EXAMPLE STENCIL DESIGN

DRB0008B

VSON - 1 mm max height

PLASTIC SMALL OUTLINE - NO LEAD



SOLDER PASTE EXAMPLE
BASED ON 0.125 mm THICK STENCIL

EXPOSED PAD
81% PRINTED SOLDER COVERAGE BY AREA
SCALE:25X

4218876/A 12/2017

NOTES: (continued)

6. Laser cutting apertures with trapezoidal walls and rounded corners may offer better paste release. IPC-7525 may have alternate design recommendations.

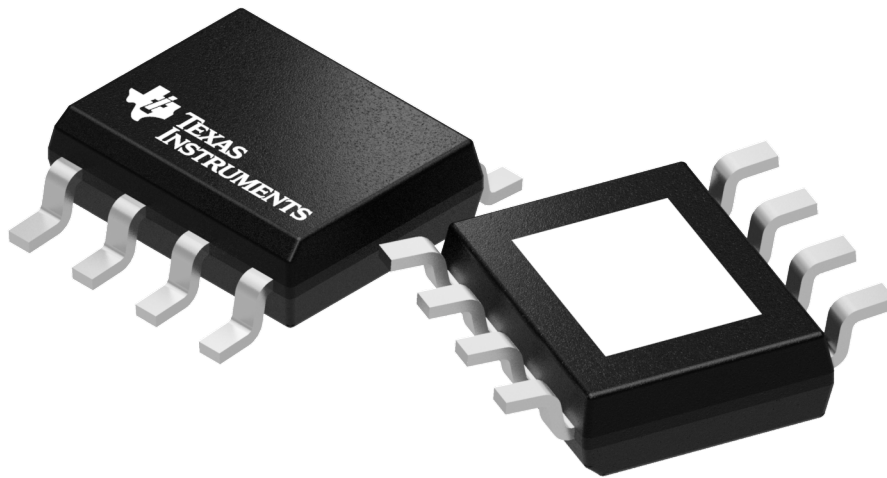

Images above are just a representation of the package family, actual package may vary.
Refer to the product data sheet for package details.

DDA0008J

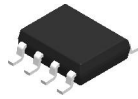

PACKAGE OUTLINE

PowerPAD™ SOIC - 1.7 mm max height

PLASTIC SMALL OUTLINE

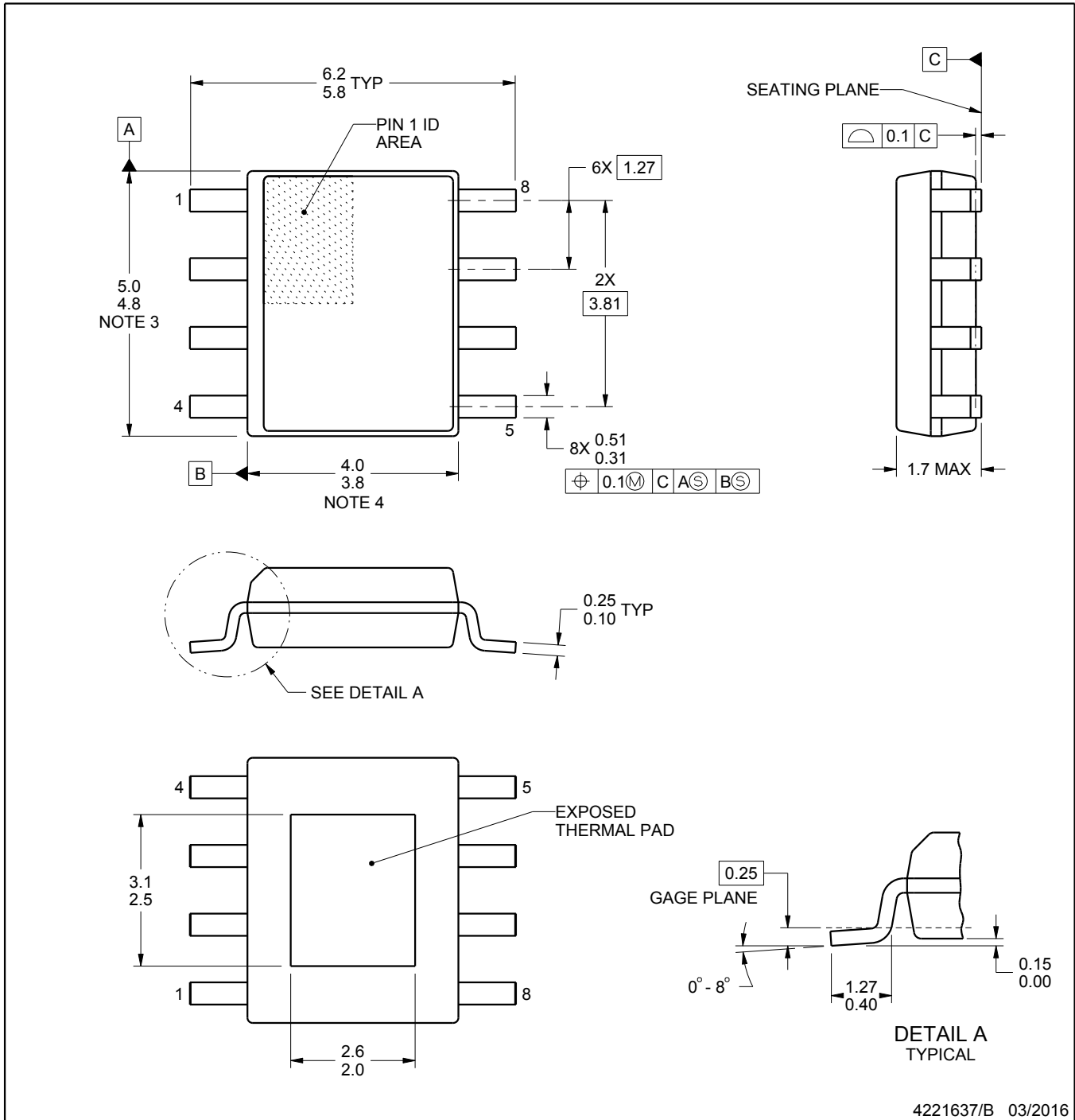

PowerPAD is a trademark of Texas Instruments.

NOTES:

1. All linear dimensions are in millimeters. Any dimensions in parenthesis are for reference only. Dimensioning and tolerancing per ASME Y14.5M.
2. This drawing is subject to change without notice.
3. This dimension does not include mold flash, protrusions, or gate burrs. Mold flash, protrusions, or gate burrs shall not exceed 0.15 mm per side.
4. This dimension does not include interlead flash. Interlead flash shall not exceed 0.25 mm per side.
5. Reference JEDEC registration MS-012, variation BA.

EXAMPLE STENCIL DESIGN

DDA0008J

PowerPAD™ SOIC - 1.7 mm max height

PLASTIC SMALL OUTLINE

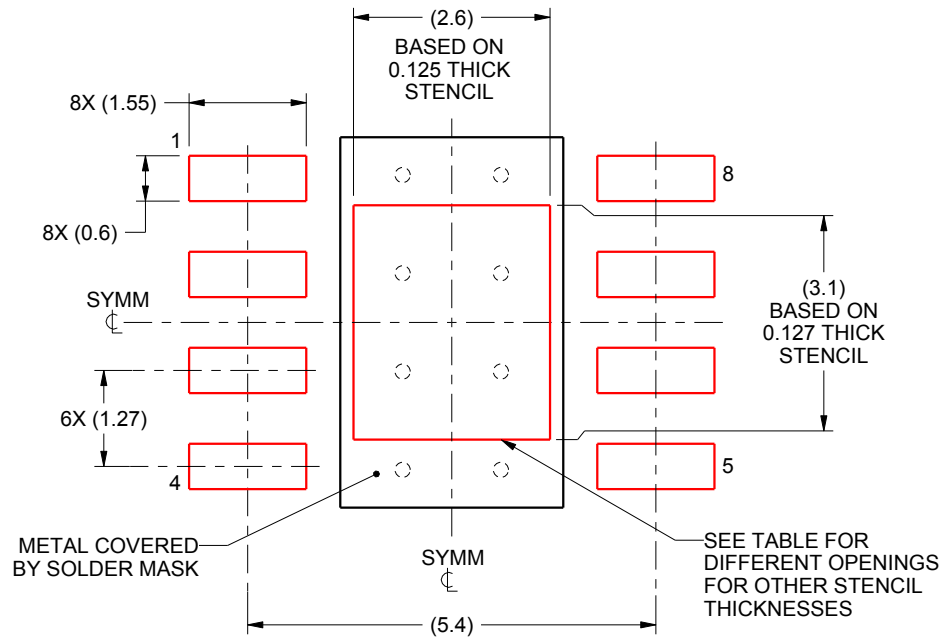

SOLDER PASTE EXAMPLE
 EXPOSED PAD
 100% PRINTED SOLDER COVERAGE BY AREA
 SCALE:10X

| STENCIL THICKNESS | SOLDER STENCIL OPENING |
|-------------------|------------------------|
| 0.1 | 2.91 X 3.47 |
| 0.125 | 2.6 X 3.1 (SHOWN) |
| 0.150 | 2.37 X 2.83 |
| 0.175 | 2.20 X 2.62 |

4221637/B 03/2016

NOTES: (continued)

- 10. Laser cutting apertures with trapezoidal walls and rounded corners may offer better paste release. IPC-7525 may have alternate design recommendations.
- 11. Board assembly site may have different recommendations for stencil design.



D0008A

PACKAGE OUTLINE

SOIC - 1.75 mm max height

SMALL OUTLINE INTEGRATED CIRCUIT



4214825/C 02/2019

NOTES:

- Linear dimensions are in inches [millimeters]. Dimensions in parenthesis are for reference only. Controlling dimensions are in inches. Dimensioning and tolerancing per ASME Y14.5M.
- This drawing is subject to change without notice.
- This dimension does not include mold flash, protrusions, or gate burrs. Mold flash, protrusions, or gate burrs shall not exceed $.006$ [0.15] per side.
- This dimension does not include interlead flash.
- Reference JEDEC registration MS-012, variation AA.

EXAMPLE BOARD LAYOUT

D0008A

SOIC - 1.75 mm max height

SMALL OUTLINE INTEGRATED CIRCUIT



LAND PATTERN EXAMPLE
 EXPOSED METAL SHOWN
 SCALE:8X



SOLDER MASK DETAILS

4214825/C 02/2019

NOTES: (continued)

- 6. Publication IPC-7351 may have alternate designs.
- 7. Solder mask tolerances between and around signal pads can vary based on board fabrication site.

EXAMPLE STENCIL DESIGN

D0008A

SOIC - 1.75 mm max height

SMALL OUTLINE INTEGRATED CIRCUIT



SOLDER PASTE EXAMPLE
BASED ON .005 INCH [0.125 MM] THICK STENCIL
SCALE:8X

4214825/C 02/2019

NOTES: (continued)

8. Laser cutting apertures with trapezoidal walls and rounded corners may offer better paste release. IPC-7525 may have alternate design recommendations.
9. Board assembly site may have different recommendations for stencil design.

IMPORTANT NOTICE AND DISCLAIMER

TI PROVIDES TECHNICAL AND RELIABILITY DATA (INCLUDING DATA SHEETS), DESIGN RESOURCES (INCLUDING REFERENCE DESIGNS), APPLICATION OR OTHER DESIGN ADVICE, WEB TOOLS, SAFETY INFORMATION, AND OTHER RESOURCES "AS IS" AND WITH ALL FAULTS, AND DISCLAIMS ALL WARRANTIES, EXPRESS AND IMPLIED, INCLUDING WITHOUT LIMITATION ANY IMPLIED WARRANTIES OF MERCHANTABILITY, FITNESS FOR A PARTICULAR PURPOSE OR NON-INFRINGEMENT OF THIRD PARTY INTELLECTUAL PROPERTY RIGHTS.

These resources are intended for skilled developers designing with TI products. You are solely responsible for (1) selecting the appropriate TI products for your application, (2) designing, validating and testing your application, and (3) ensuring your application meets applicable standards, and any other safety, security, regulatory or other requirements.

These resources are subject to change without notice. TI grants you permission to use these resources only for development of an application that uses the TI products described in the resource. Other reproduction and display of these resources is prohibited. No license is granted to any other TI intellectual property right or to any third party intellectual property right. TI disclaims responsibility for, and you will fully indemnify TI and its representatives against, any claims, damages, costs, losses, and liabilities arising out of your use of these resources.

TI's products are provided subject to [TI's Terms of Sale](#) or other applicable terms available either on [ti.com](https://www.ti.com) or provided in conjunction with such TI products. TI's provision of these resources does not expand or otherwise alter TI's applicable warranties or warranty disclaimers for TI products.

TI objects to and rejects any additional or different terms you may have proposed.

Mailing Address: Texas Instruments, Post Office Box 655303, Dallas, Texas 75265
Copyright © 2023, Texas Instruments Incorporated

Looking for pricing, stock, or lifecycle information?

Click below to explore more details on WIN SOURCE:

 [View BUF634AIDDAR](#) on WIN SOURCE

 [Texas Instruments](#) Information

Optimize Your Supply Chain with WIN SOURCE Solutions

-  Global Sourcing Solution
-  Obsolete Management
-  Cost Control Management
-  Shortage Management
-  Alternative Solution
-  Excess Inventory Management