



# THE DATASHEET OF G01N20LE



## N-Channel Enhancement Mode Power MOSFET

### Description

The G01N20LE uses advanced trench technology to provide excellent  $R_{DS(ON)}$ , low gate charge. It can be used in a wide variety of applications.

### General Features

- $V_{DS}$  200V
- $I_D$  (at  $V_{GS} = 10V$ ) 1.7A
- $R_{DS(ON)}$  (at  $V_{GS} = 10V$ ) <  $0.7\Omega$
- $R_{DS(ON)}$  (at  $V_{GS} = 4.5V$ ) <  $0.72\Omega$
- 100% Avalanche Tested
- RoHS Compliant
- ESD (HBM): 2KV

### Application

- Power switch
- DC/DC converters

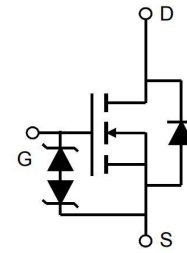

Schematic diagram

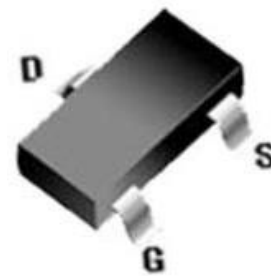

SOT-23-3L

### Ordering Information

Device	Package	Marking	Packaging
G01N20LE	SOT-23-3L	G01N20	3000pcs/Reel

### Absolute Maximum Ratings $T_C = 25^\circ C$ , unless otherwise noted

Parameter	Symbol	Value	Unit
Drain-Source Voltage	$V_{DS}$	200	V
Continuous Drain Current	$I_D$	1.7	A
Pulsed Drain Current (note1)	$I_{DM}$	6.8	A
Gate-Source Voltage	$V_{GS}$	$\pm 20$	V
Power Dissipation	$P_D$	1.5	W
Operating Junction and Storage Temperature Range	$T_J, T_{stg}$	-55 To 150	$^\circ C$

### Thermal Resistance

Parameter	Symbol	Value	Unit
Thermal Resistance, Junction-to-Ambient	$R_{thJA}$	83	$^\circ C/W$

Specifications $T_J = 25^\circ\text{C}$ , unless otherwise noted						
Parameter	Symbol	Test Conditions	Value			Unit
			Min.	Typ.	Max.	
<b>Static Parameters</b>						
Drain-Source Breakdown Voltage	$V_{(BR)DSS}$	$V_{GS} = 0V, I_D = 250\mu A$	200	--	--	V
Zero Gate Voltage Drain Current	$I_{DSS}$	$V_{DS} = 200V, V_{GS} = 0V$	--	--	1	$\mu A$
Gate-Source Leakage	$I_{GSS}$	$V_{GS} = \pm 20V$	--	--	$\pm 30$	$\mu A$
Gate-Source Threshold Voltage	$V_{GS(th)}$	$V_{DS} = V_{GS}, I_D = 250\mu A$	1.0	1.9	2.5	V
Drain-Source On-Resistance	$R_{DS(on)}$	$V_{GS} = 10V, I_D = 1A$	--	0.58	0.70	$\Omega$
		$V_{GS} = 4.5V, I_D = 1A$	--	0.59	0.72	
Forward Transconductance	$g_{FS}$	$V_{GS} = 5V, I_D = 1A$	--	8	--	S
<b>Dynamic Parameters</b>						
Input Capacitance	$C_{iss}$	$V_{GS} = 0V,$ $V_{DS} = 100V,$ $f = 1.0MHz$	--	515	--	pF
Output Capacitance	$C_{oss}$		--	16	--	
Reverse Transfer Capacitance	$C_{rss}$		--	11	--	
Total Gate Charge	$Q_g$	$V_{DD} = 100V,$ $I_D = 1A,$ $V_{GS} = 10V$	--	12	--	nC
Gate-Source Charge	$Q_{gs}$		--	2.5	--	
Gate-Drain Charge	$Q_{gd}$		--	3.8	--	
Turn-on Delay Time	$t_{d(on)}$	$V_{DD} = 100V,$ $I_D = 1A,$ $R_G = 2.5\Omega$	--	10	--	ns
Turn-on Rise Time	$t_r$		--	12	--	
Turn-off Delay Time	$t_{d(off)}$		--	15	--	
Turn-off Fall Time	$t_f$		--	15	--	
<b>Drain-Source Body Diode Characteristics</b>						
Continuous Body Diode Current	$I_S$	$T_C = 25^\circ\text{C}$	--	--	1.7	A
Body Diode Voltage	$V_{SD}$	$T_J = 25^\circ\text{C}, I_{SD} = 1A, V_{GS} = 0V$	--	--	1.2	V
Reverse Recovery Charge	$Q_{rr}$	$I_F = 1A, V_{GS} = 0V$ $di/dt = 100A/\mu s$	--	663	--	nC
Reverse Recovery Time	$T_{rr}$		--	201	--	ns

### Notes

1. Repetitive Rating: Pulse width limited by maximum junction temperature
2. Identical low side and high side switch with identical  $R_G$

### Gate Charge Test Circuit

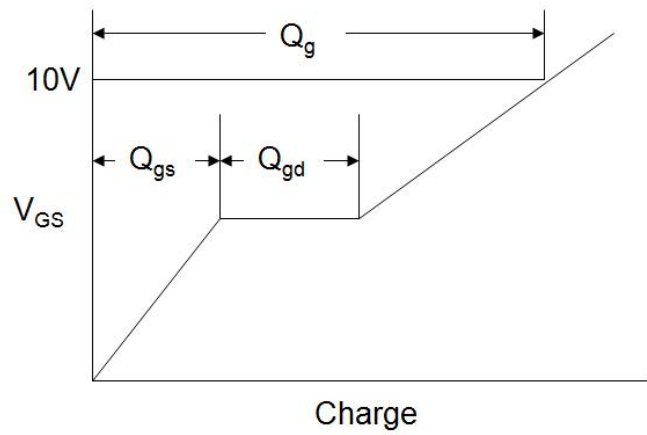
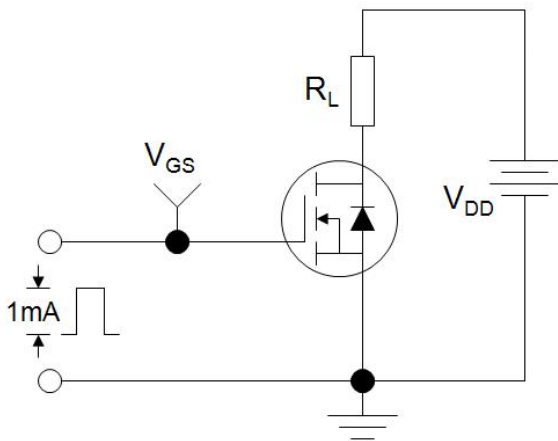

### Switch Time Test Circuit

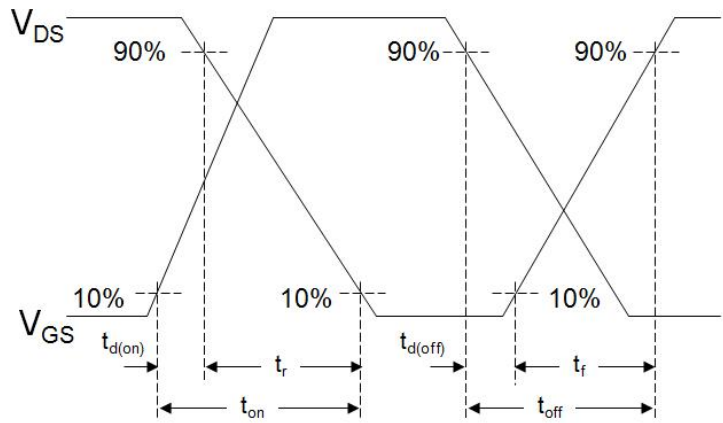
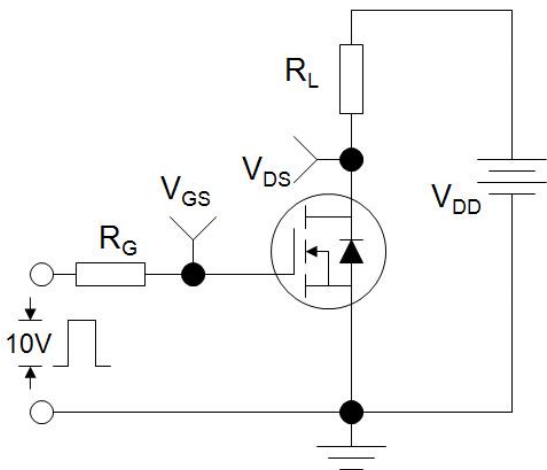

### EAS Test Circuit

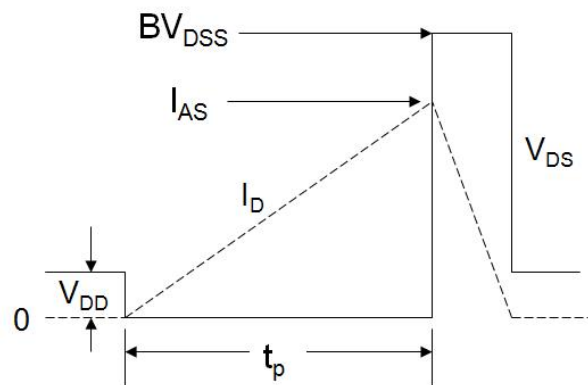
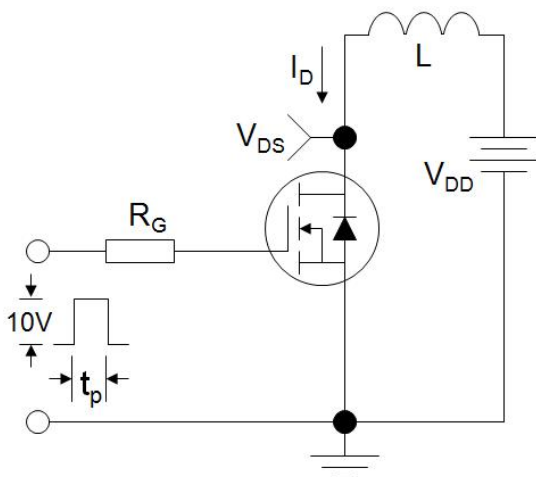

Typical Characteristics  $T_J = 25^\circ\text{C}$ , unless otherwise noted

**Figure 1. Output Characteristics**

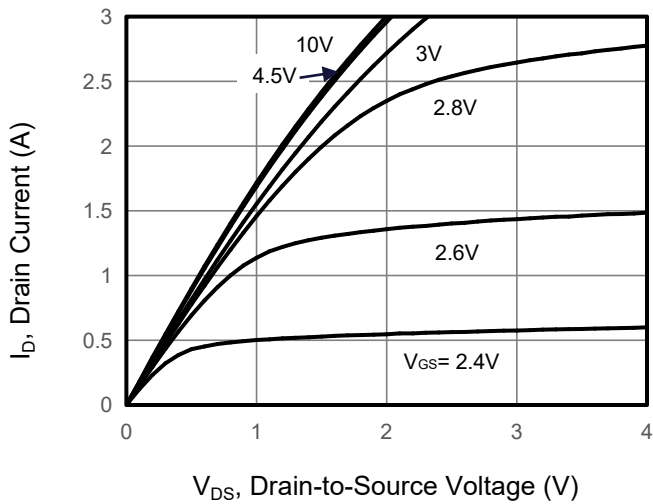

**Figure 2. Transfer Characteristics**

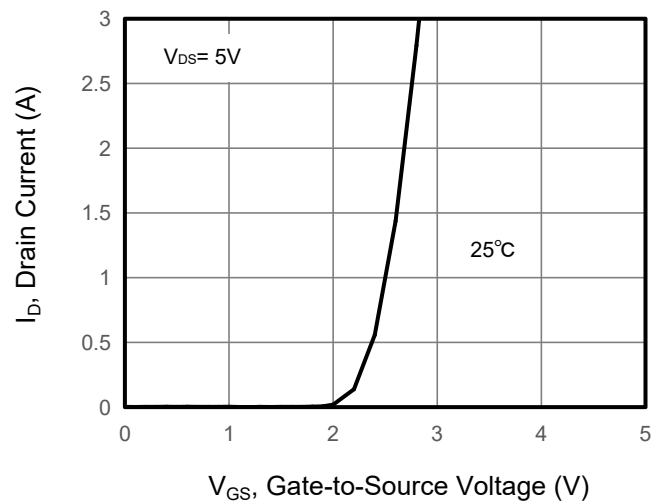

**Figure 3. Drain Source On Resistance**

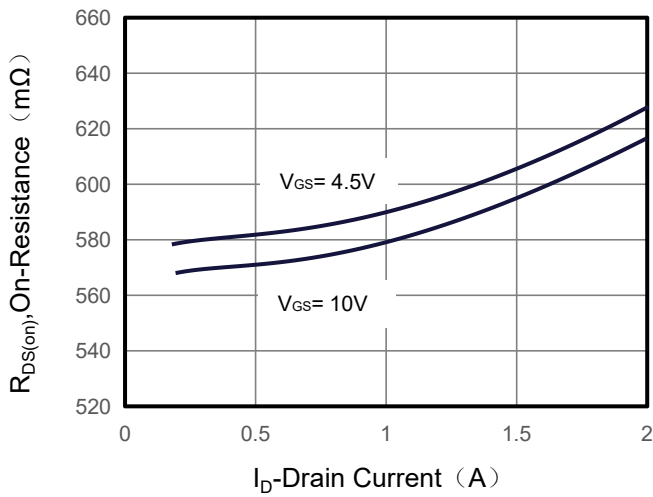

**Figure 4. Gate Charge**

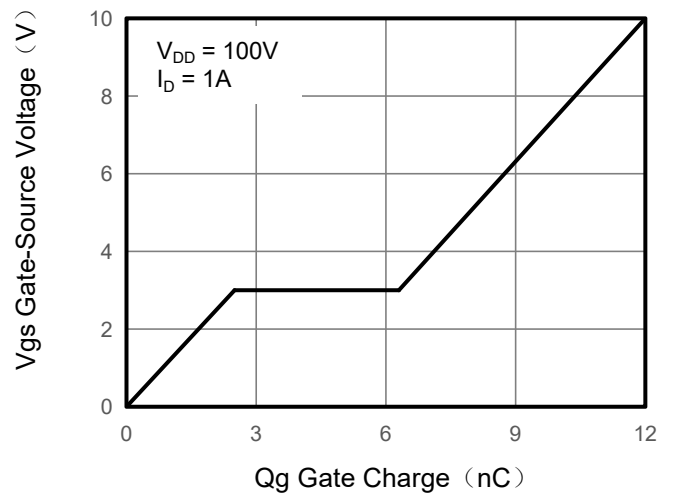

**Figure 5. Capacitance**

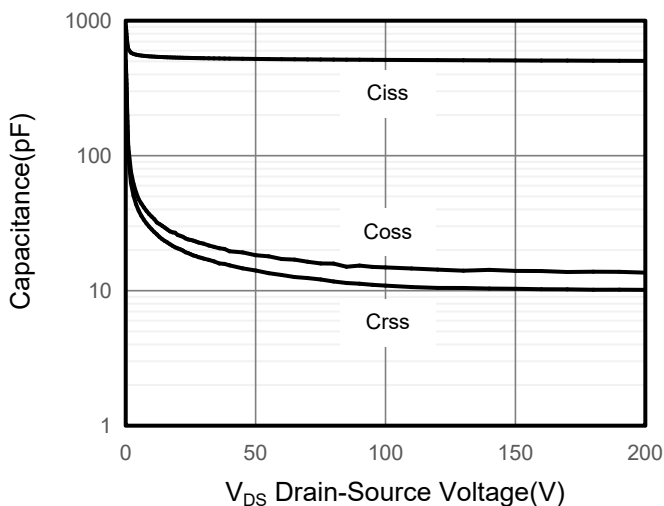

**Figure 6. Source-Drain Diode Forward**

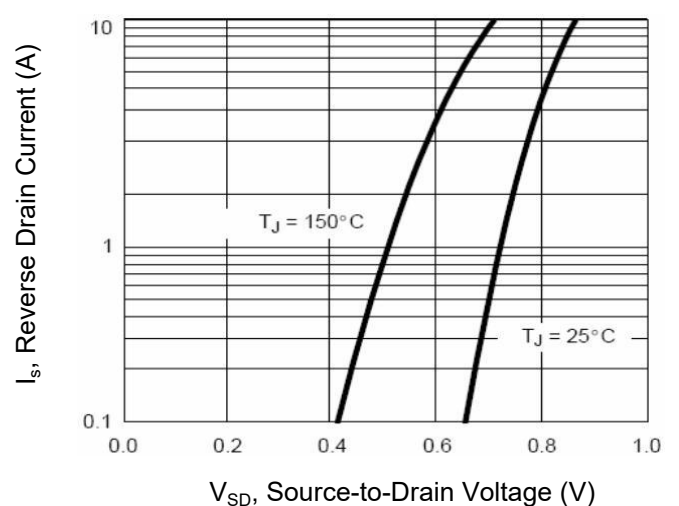

Typical Characteristics  $T_J = 25^\circ\text{C}$ , unless otherwise noted

Figure 7. Drain-Source On-Resistance

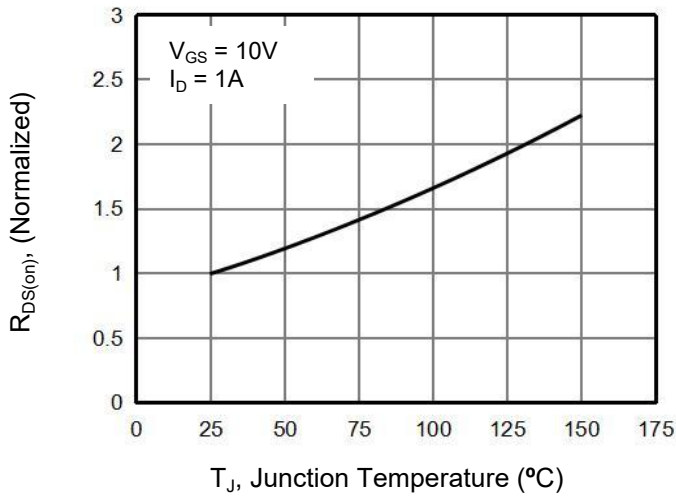

Figure 8. Safe Operation Area

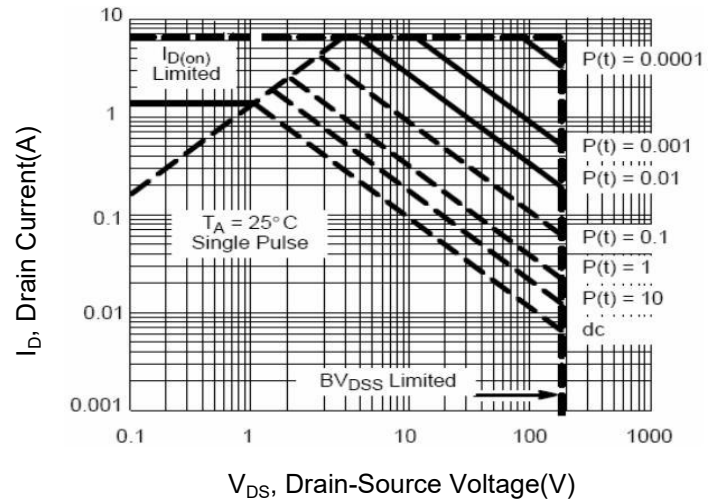
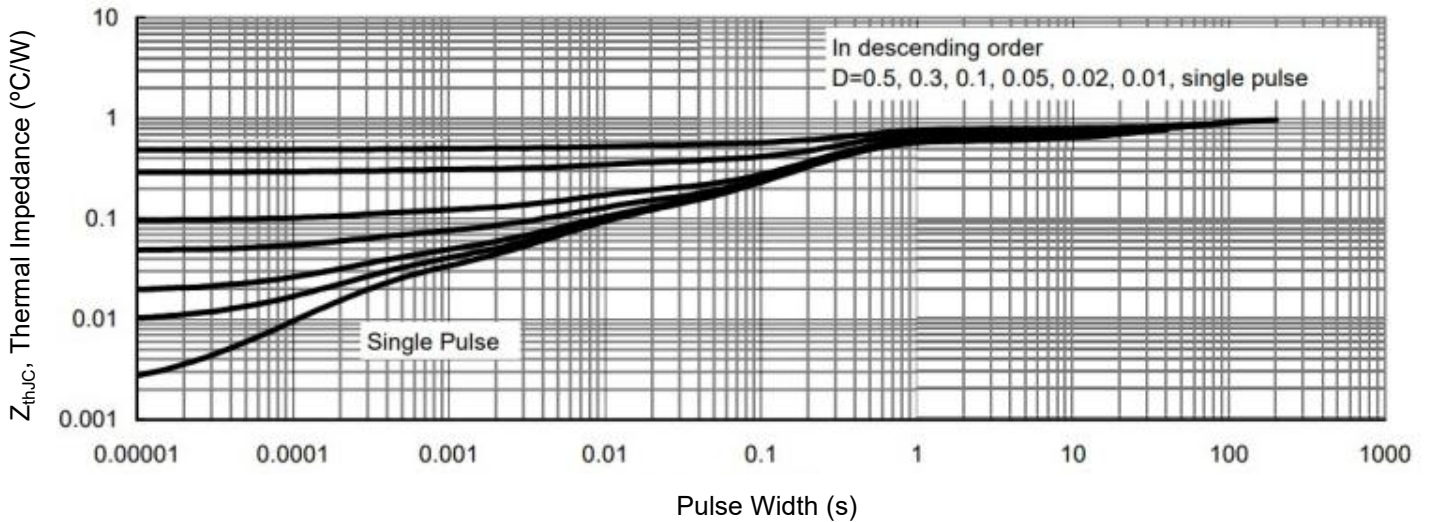
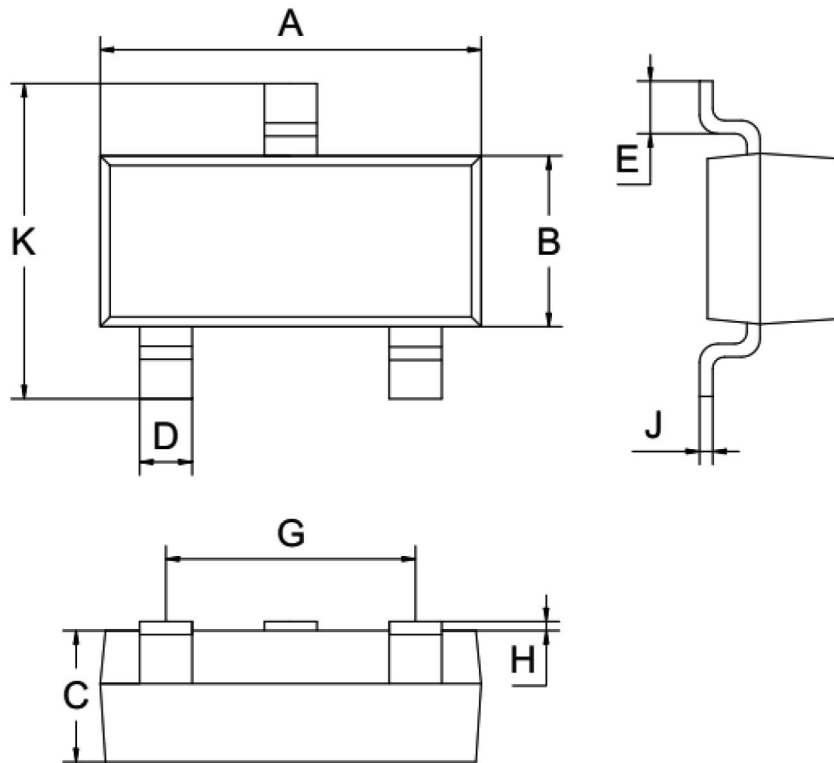

Figure 9. Normalized Maximum Transient Thermal Impedance





## SOT-23-3L Package Information



Symbol	Dimensions in Millimeters		
	MIN.	NOM.	MAX.
A	2.80	2.90	3.00
B	1.50	1.60	1.70
C	1.00	1.10	1.20
D	0.30	0.40	0.50
E	0.25	0.40	0.55
G	1.90		
H	0.00	-	0.10
J	0.047	0.127	0.207
K	2.60	2.80	3.00
All Dimensions in mm			

## Looking for pricing, stock, or lifecycle information?

Click below to explore more details on WIN SOURCE:

-  [View G01N20LE on WIN SOURCE](#)
-  [Goford Semiconductor Information](#)

## Optimize Your Supply Chain with WIN SOURCE Solutions

-  Global Sourcing Solution
-  Obsolete Management
-  Cost Control Management
-  Shortage Management
-  Alternative Solution
-  Excess Inventory Management