

Features

- Epitaxial Planar Die Construction
- Built-In Biasing Resistors
- Surface Mount Package Suited for Automated Assembly
- **Totally Lead-Free & Fully RoHS Compliant (Notes 1 & 2)**
- **Halogen and Antimony Free. "Green" Device (Note 3)**
- **For automotive applications requiring specific change control (i.e. parts qualified to AEC-Q100/101/104/200, PPAP capable, and manufactured in IATF 16949 certified facilities), please contact us or your local Diodes representative.**
<https://www.diodes.com/quality/product-definitions/>

Mechanical Data

- Package: SOT323
- Package Material: Molded Plastic, "Green" Molding Compound; UL Flammability Classification Rating 94V-0
- Moisture Sensitivity: Level 1 per J-STD-020
- Terminals: Finish – Matte Tin Plated Leads, Solderable per MIL-STD-202, Method 208 (Ⓒ3)
- Weight: 0.006 grams (Approximate)

Part Number	R1(NOM)	R2(NOM)
DDTC113ZUA	1kΩ	10kΩ
DDTC123YUA	2.2kΩ	10kΩ
DDTC123JUA	2.2kΩ	47kΩ
DDTC143XUA	4.7kΩ	10kΩ
DDTC143FUA	4.7kΩ	22kΩ
DDTC143ZUA	4.7kΩ	47kΩ
DDTC114YUA	10kΩ	47kΩ
DDTC114WUA	10kΩ	4.7kΩ
DDTC124XUA	22kΩ	47kΩ
DDTC144VUA	47kΩ	10kΩ
DDTC144WUA	47kΩ	22kΩ



Top View

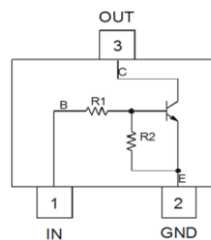

Device Schematic

Ordering Information (Note 4)

Orderable Part Number	Package	Marking	Reel Size (inches)	Tape Width (mm)	Packing	
					Quantity	Carrier
DDTC113ZUA-7-F	SOT323	N02	7	8	3,000	Reel
DDTC123YUA-7-F	SOT323	N05	7	8	3,000	Reel
DDTC123JUA-7-F	SOT323	N06	7	8	3,000	Reel
DDTC143XUA-7-F	SOT323	N09	7	8	3,000	Reel
DDTC143FUA-7-F	SOT323	N10	7	8	3,000	Reel
DDTC143ZUA-7-F	SOT323	N11	7	8	3,000	Reel
DDTC114YUA-7-F	SOT323	N14	7	8	3,000	Reel
DDTC114WUA-7-F	SOT323	N15	7	8	3,000	Reel
DDTC124XUA-7-F	SOT323	N18	7	8	3,000	Reel
DDTC144VUA-7-F	SOT323	N21	7	8	3,000	Reel
DDTC144WUA-7-F	SOT323	N22	7	8	3,000	Reel

- Notes:
1. No purposely added lead. Fully EU Directive 2002/95/EC (RoHS), 2011/65/EU (RoHS 2) & 2015/863/EU (RoHS 3) compliant.
 2. See <https://www.diodes.com/quality/lead-free/> for more information about Diodes Incorporated's definitions of Halogen- and Antimony-free, "Green" and Lead-free.
 3. Halogen- and Antimony-free "Green" products are defined as those which contain <900ppm bromine, <900ppm chlorine (<1500ppm total Br + Cl) and <1000ppm antimony compounds.
 4. For packaging details, go to our website at <https://www.diodes.com/design/support/packaging/diodes-packaging/>.

Marking Information

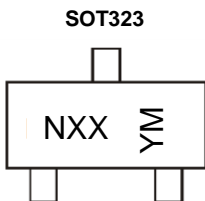

NXX = Product Type Marking Code
 YM = Date Code Marking
 Y or \bar{Y} = Year (ex: K = 2023)
 M = Month (ex: D = December)

Date Code Key

Year	2020	2023	2024	2025	2026	2027	2028	2029	2030	2031	2032
Code	H	K	L	M	N	P	R	S	T	U	V

Month	Jan	Feb	Mar	Apr	May	Jun	Jul	Aug	Sep	Oct	Nov	Dec
Code	1	2	3	4	5	6	7	8	9	O	N	D

Absolute Maximum Ratings NPN Section (@ $T_{amb} = +25^{\circ}\text{C}$, unless otherwise specified.)

Characteristic	Symbol	Value	Unit
Supply Voltage <Pin: (3) to (2)>	V_{CC}	50	V
Input Voltage <Pin: (1) to (2)>	V_{IN}	DDTC113ZUA	-5 to +10
		DDTC123YUA	-5 to +12
		DDTC123JUA	-5 to +12
		DDTC143XUA	-7 to +20
		DDTC143FUA	-6 to +30
		DDTC143ZUA	-5 to +30
		DDTC114YUA	-6 to +40
		DDTC114WUA	-10 to +30
		DDTC124XUA	-10 to +40
		DDTC144VUA	-15 to +40
DDTC144WUA	-10 to +40		
Output Current	I_{OUT}	DDTC113ZUA	100
		DDTC123YUA	100
		DDTC123JUA	100
		DDTC143XUA	100
		DDTC143FUA	100
		DDTC143ZUA	100
		DDTC114YUA	70
		DDTC114WUA	100
		DDTC124XUA	50
		DDTC144VUA	30
DDTC144WUA	30		
Output Current	I_C (max)	100	mA

Thermal Characteristics (@ $T_{amb} = +25^{\circ}\text{C}$, unless otherwise specified.)

Characteristic	Symbol	Value	Unit
Power Dissipation (Notes 5, 6)	P_D	200	mW
Thermal Resistance, Junction to Ambient Air (Note 5)	$R_{\theta JA}$	625	$^{\circ}\text{C}/\text{W}$
Operating and Storage Temperature Range	T_J, T_{STG}	-55 to +150	$^{\circ}\text{C}$

Notes: 5. Mounted on FR4 PC Board with minimum recommended pad layout.
 6. 150mW per element must not be exceeded.

Electrical Characteristics (@T_{amb} = +25°C, unless otherwise specified.)

Characteristic		Symbol	Min	Typ	Max	Unit	Test Condition	
Input Voltage	DDTC113ZUA	V _{IN(off)}	0.3	—	—	V	V _{CC} = 5V, I _{OUT} = 100μA	
	DDTC123YUA		0.3					
	DDTC123JUA		0.5					
	DDTC143XUA		0.3					
	DDTC143FUA		0.3					
	DDTC143ZUA		0.5					
	DDTC114YUA		0.3					
	DDTC114WUA		0.8					
	DDTC124XUA		0.4					
	DDTC144VUA		1.0					
	DDTC144WUA		0.8					
	DDTC113ZUA		V _{IN(on)}					—
	DDTC123YUA	3.0		V _{OUT} = 0.3V, I _{OUT} = 20mA				
	DDTC123JUA	1.1		V _{OUT} = 0.3V, I _{OUT} = 5mA				
	DDTC143XUA	2.5		V _{OUT} = 0.3V, I _{OUT} = 20mA				
	DDTC143FUA	1.3		V _{OUT} = 0.3V, I _{OUT} = 3mA				
	DDTC143ZUA	1.3		V _{OUT} = 0.3V, I _{OUT} = 5mA				
	DDTC114YUA	1.4		V _{OUT} = 0.3V, I _{OUT} = 1mA				
	DDTC114WUA	3.0		V _{OUT} = 0.3V, I _{OUT} = 2mA				
	DDTC124XUA	2.5		V _{OUT} = 0.3V, I _{OUT} = 2mA				
	DDTC144VUA	5.0		V _{OUT} = 0.3V, I _{OUT} = 2mA				
	DDTC144WUA	4.0		V _{OUT} = 0.3V, I _{OUT} = 2mA				
Output Voltage		V _{OUT(on)}		—	0.1	0.3	V	
Input Current	DDTC113ZUA	I _{IN}	—	—	7.2	mA	V _{IN} = 5V	
	DDTC123YUA				3.8			
	DDTC123JUA				3.6			
	DDTC143XUA				1.8			
	DDTC143FUA				1.8			
	DDTC143ZUA				1.8			
	DDTC114YUA				0.88			
	DDTC114WUA				0.88			
	DDTC124XUA				0.36			
	DDTC144VUA				0.16			
	DDTC144WUA				0.16			
	Output Current							I _{OUT(off)}
DC Current Gain	DDTC113ZUA	G _I	—	—	—	—	V _{OUT} = 5V, I _{OUT} = 5mA	
	DDTC123YUA						33	V _{OUT} = 5V, I _{OUT} = 10mA
	DDTC123JUA						80	V _{OUT} = 5V, I _{OUT} = 10mA
	DDTC143XUA						30	V _{OUT} = 5V, I _{OUT} = 10mA
	DDTC143FUA						68	V _{OUT} = 5V, I _{OUT} = 10mA
	DDTC143ZUA						80	V _{OUT} = 5V, I _{OUT} = 10mA
	DDTC114YUA						68	V _{OUT} = 5V, I _{OUT} = 5mA
	DDTC114WUA						24	V _{OUT} = 5V, I _{OUT} = 10mA
	DDTC124XUA						68	V _{OUT} = 5V, I _{OUT} = 5mA
	DDTC144VUA						33	V _{OUT} = 5V, I _{OUT} = 5mA
	DDTC144WUA						56	V _{OUT} = 5V, I _{OUT} = 5mA
	Input Resistor (R ₁) Tolerance							ΔR ₁
Resistance Ratio Tolerance		ΔR ₂ /R ₁	-20	—	+20	%	—	
Gain-Bandwidth Product		f _T	—	250	—	MHz	V _{CE} = 10V, I _E = 5mA, f = 100MHz	

Typical Curves – Total Device

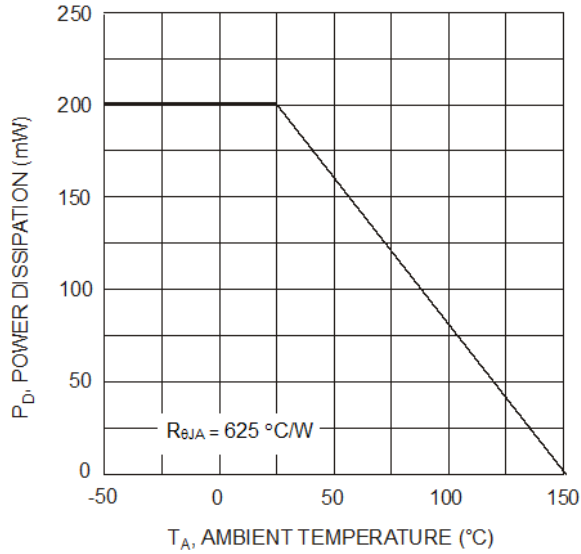

Figure 1. Derating Curve

Typical Curves – DDTC123JUA (@T_A = +25°C, unless otherwise specified.)

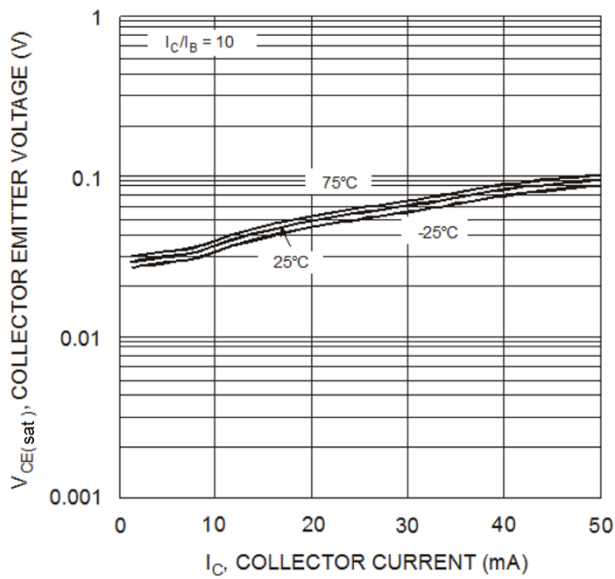

Figure 2. V_{CE(sat)} VS I_C

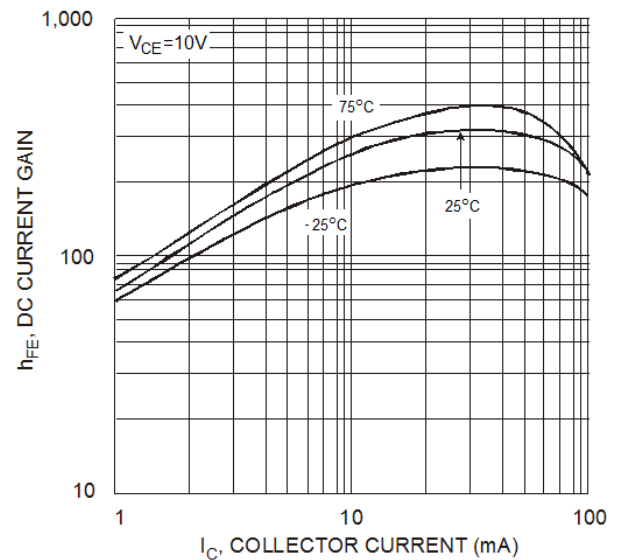

Figure 3. DC Current Gain

Typical Curves – DDTC123JUA (continued)

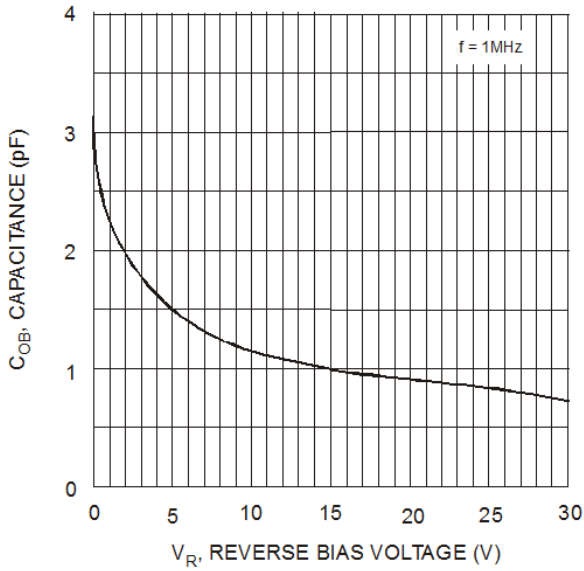

Figure 4. Output Capacitance

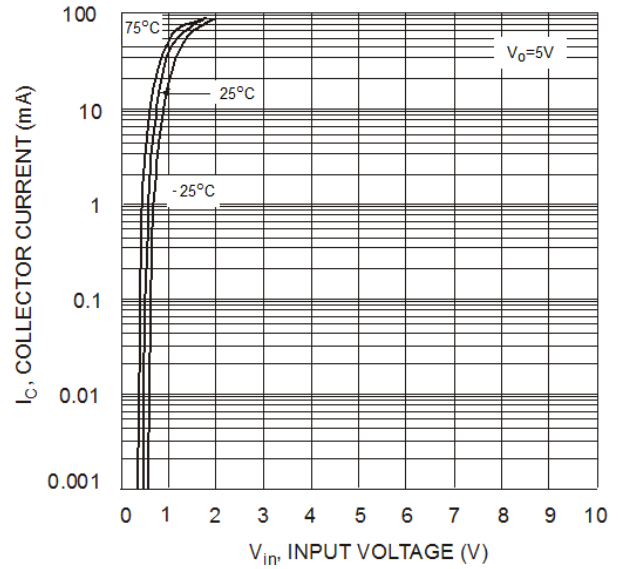

Figure 5. Collector Current vs Input Voltage

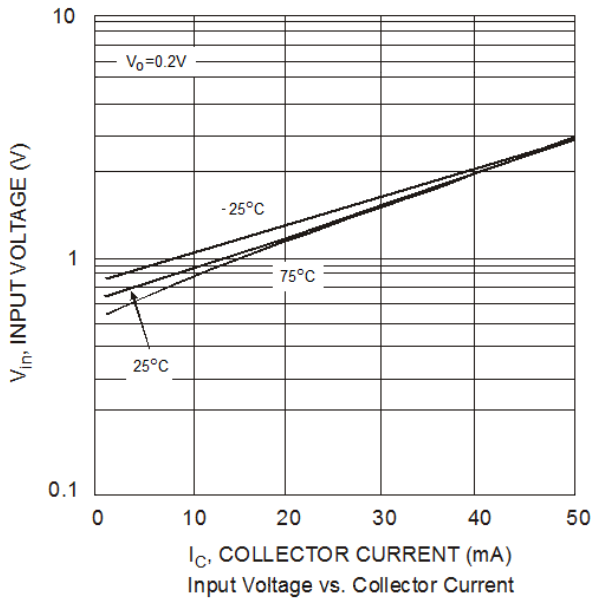
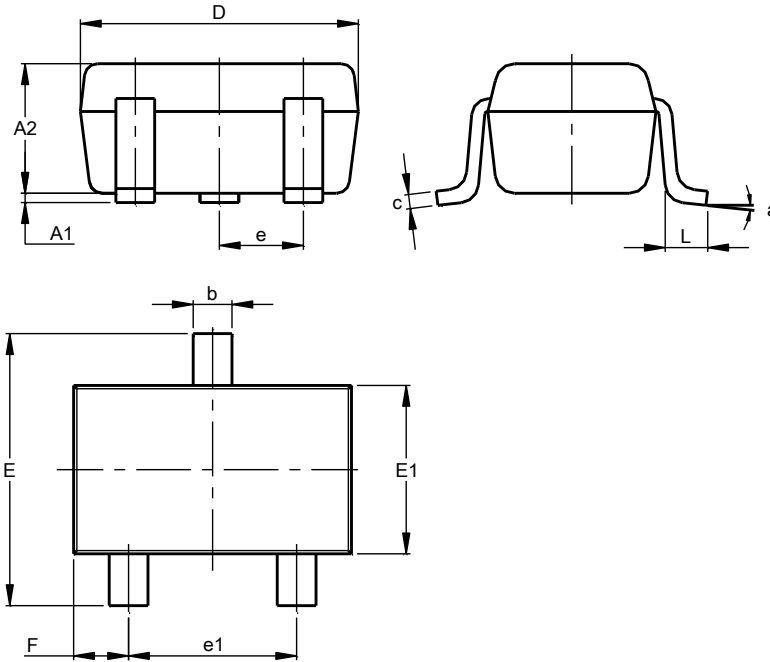

Figure 6. Input Voltage vs Collector Current

Package Outline Dimensions

Please see <http://www.diodes.com/package-outlines.html> for the latest version.

SOT323



SOT323			
Dim	Min	Max	Typ
A1	0.00	0.10	0.05
A2	0.90	1.00	0.95
b	0.25	0.40	0.30
c	0.10	0.18	0.11
D	1.80	2.20	2.15
E	2.00	2.20	2.10
E1	1.15	1.35	1.30
e	0.650 BSC		
e1	1.20	1.40	1.30
F	0.375	0.475	0.425
L	0.25	0.40	0.30
a	0°	8°	--
All Dimensions in mm			

Suggested Pad Layout

Please see <http://www.diodes.com/package-outlines.html> for the latest version.

SOT323

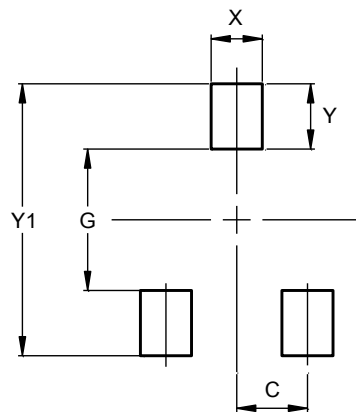

Dimensions	Value (in mm)
C	0.650
G	1.300
X	0.470
Y	0.600
Y1	2.500

IMPORTANT NOTICE

1. DIODES INCORPORATED (Diodes) AND ITS SUBSIDIARIES MAKE NO WARRANTY OF ANY KIND, EXPRESS OR IMPLIED, WITH REGARDS TO ANY INFORMATION CONTAINED IN THIS DOCUMENT, INCLUDING, BUT NOT LIMITED TO, THE IMPLIED WARRANTIES OF MERCHANTABILITY, FITNESS FOR A PARTICULAR PURPOSE OR NON-INFRINGEMENT OF THIRD PARTY INTELLECTUAL PROPERTY RIGHTS (AND THEIR EQUIVALENTS UNDER THE LAWS OF ANY JURISDICTION).
2. The Information contained herein is for informational purpose only and is provided only to illustrate the operation of Diodes' products described herein and application examples. Diodes does not assume any liability arising out of the application or use of this document or any product described herein. This document is intended for skilled and technically trained engineering customers and users who design with Diodes' products. Diodes' products may be used to facilitate safety-related applications; however, in all instances customers and users are responsible for (a) selecting the appropriate Diodes products for their applications, (b) evaluating the suitability of Diodes' products for their intended applications, (c) ensuring their applications, which incorporate Diodes' products, comply the applicable legal and regulatory requirements as well as safety and functional-safety related standards, and (d) ensuring they design with appropriate safeguards (including testing, validation, quality control techniques, redundancy, malfunction prevention, and appropriate treatment for aging degradation) to minimize the risks associated with their applications.
3. Diodes assumes no liability for any application-related information, support, assistance or feedback that may be provided by Diodes from time to time. Any customer or user of this document or products described herein will assume all risks and liabilities associated with such use, and will hold Diodes and all companies whose products are represented herein or on Diodes' websites, harmless against all damages and liabilities.
4. Products described herein may be covered by one or more United States, international or foreign patents and pending patent applications. Product names and markings noted herein may also be covered by one or more United States, international or foreign trademarks and trademark applications. Diodes does not convey any license under any of its intellectual property rights or the rights of any third parties (including third parties whose products and services may be described in this document or on Diodes' website) under this document.
5. Diodes' products are provided subject to Diodes' Standard Terms and Conditions of Sale (<https://www.diodes.com/about/company/terms-and-conditions/terms-and-conditions-of-sales/>) or other applicable terms. This document does not alter or expand the applicable warranties provided by Diodes. Diodes does not warrant or accept any liability whatsoever in respect of any products purchased through unauthorized sales channel.
6. Diodes' products and technology may not be used for or incorporated into any products or systems whose manufacture, use or sale is prohibited under any applicable laws and regulations. Should customers or users use Diodes' products in contravention of any applicable laws or regulations, or for any unintended or unauthorized application, customers and users will (a) be solely responsible for any damages, losses or penalties arising in connection therewith or as a result thereof, and (b) indemnify and hold Diodes and its representatives and agents harmless against any and all claims, damages, expenses, and attorney fees arising out of, directly or indirectly, any claim relating to any noncompliance with the applicable laws and regulations, as well as any unintended or unauthorized application.
7. While efforts have been made to ensure the information contained in this document is accurate, complete and current, it may contain technical inaccuracies, omissions and typographical errors. Diodes does not warrant that information contained in this document is error-free and Diodes is under no obligation to update or otherwise correct this information. Notwithstanding the foregoing, Diodes reserves the right to make modifications, enhancements, improvements, corrections or other changes without further notice to this document and any product described herein. This document is written in English but may be translated into multiple languages for reference. Only the English version of this document is the final and determinative format released by Diodes.
8. Any unauthorized copying, modification, distribution, transmission, display or other use of this document (or any portion hereof) is prohibited. Diodes assumes no responsibility for any losses incurred by the customers or users or any third parties arising from any such unauthorized use.
9. This Notice may be periodically updated with the most recent version available at <https://www.diodes.com/about/company/terms-and-conditions/important-notice>

The Diodes logo is a registered trademark of Diodes Incorporated in the United States and other countries.
All other trademarks are the property of their respective owners.
© 2023 Diodes Incorporated. All Rights Reserved.

www.diodes.com

Looking for pricing, stock, or lifecycle information?

Click below to explore more details on WIN SOURCE:

 [View DDTTC143ZUA-7 on WIN SOURCE](#)

 [Diodes Incorporated](#) Information

Optimize Your Supply Chain with WIN SOURCE Solutions

-  Global Sourcing Solution
-  Obsolete Management
-  Cost Control Management
-  Shortage Management
-  Alternative Solution
-  Excess Inventory Management