



THE DATASHEET OF BSS84-HF



P-Channel MOSFET

BSS84-HF

P-Channel
RoHS Device
Halogen Free

Features

- V_{DS} (V) = -50V
- I_D = -130 mA
- R_{DS(ON)} < 10Ω (V_{GS}= -5V)

Circuit diagram

- G : Gate
- S : Source
- D : Drain

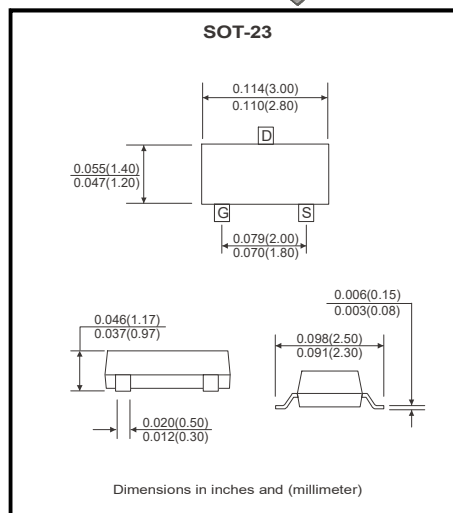
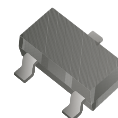
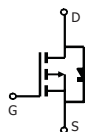

Maximum Ratings (at T_A=25°C unless otherwise noted)

Parameter	Symbol	Value	Unit
Drain-Source Voltage	V _{DS}	-50	V
Gate-Source Voltage	V _{GS}	±20	V
Continuous Drain Current	I _D	-0.13	A
Pulsed Drain Current @t _p <10 s	I _{DM}	-0.52	A
Power Dissipation	P _D	225	mW
Thermal Resistance from Junction to Ambient	R _{JA}	556	°C/W
Junction Temperature	T _J	150	°C
Storage Temperature	T _{STG}	-55~+150	°C

Electrical Characteristics (at T_A=25°C unless otherwise noted)

Parameter	Symbol	Test Conditions	Min	Typ	Max	Unit
Drain-Source Breakdown Voltage	V _{DSS}	I _D =-250μA, V _{GS} =0V	-50			V
Zero Gate Voltage Drain Current	I _{DSS}	V _{DS} =-25V, V _{GS} =0V			-0.1	A
		V _{DS} =-50V, V _{GS} =0V			-15	
Gate-Body Leakage Current	I _{GSS}	V _{DS} =0V, V _{GS} =±20V			±10	A
Gate Threshold Voltage	V _{GS(th)}	V _{DS} =V _{GS} , I _D =-1.0mA	-0.8		-2	V
Static Drain-Source On-Resistance	R _{DS(on)}	V _{GS} =-5V, I _D =-100mA			10	Ω
Forward Transconductance	g _{FS}	V _{DS} =-25V, I _D =-100mA, f=1.0KHz	50			mS
Input Capacitance	C _{iss}	V _{GS} =0V, V _{DS} =-5V, f=1MHz		30		pF
Output Capacitance	C _{oss}			10		
Reverse Transfer Capacitance	C _{rss}			5		
Turn-On DelayTime	t _{d(on)}	V _{DD} =-15V, I _D =-0.25A, R _L =50 ¹⁾		2.5		ns
Turn-On Rise Time	t _r			1		
Turn-Off DelayTime	t _{d(off)}			16		
Turn-Off Fall Time	t _f			8		
Gate Charge	Q _T			6000		PC
Maximum Body-Diode Continuous Current	I _S				-0.13	A
Maximum Body-Diode Pulsed Current	I _{SM}				-0.52	
Diode Forward Voltage	V _{SD}	I _{SD} =-130mA, V _{GS} =0V		-2.5		V

Notes :1) Switching Time is Essentially Independent of Operating Temperature.

Company reserves the right to improve product design , functions and reliability without notice.

REV:A

Typical characteristics (at $T_A=25^\circ\text{C}$ unless otherwise noted)

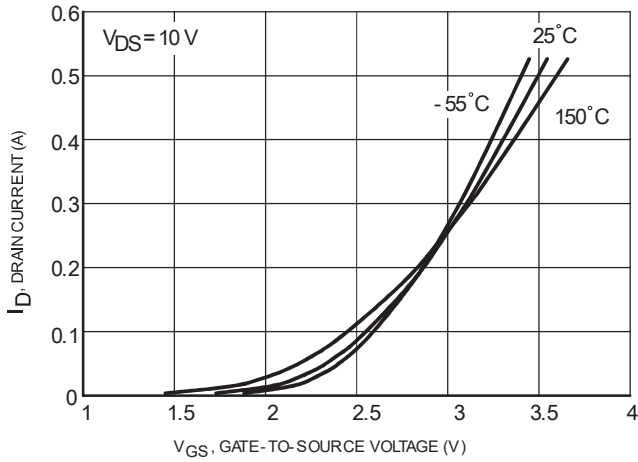

Fig1. Transfer Characteristics

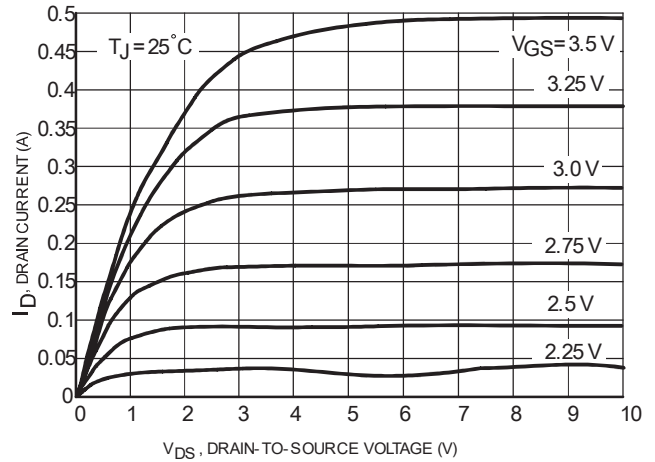

Fig2. On-Region Characteristics

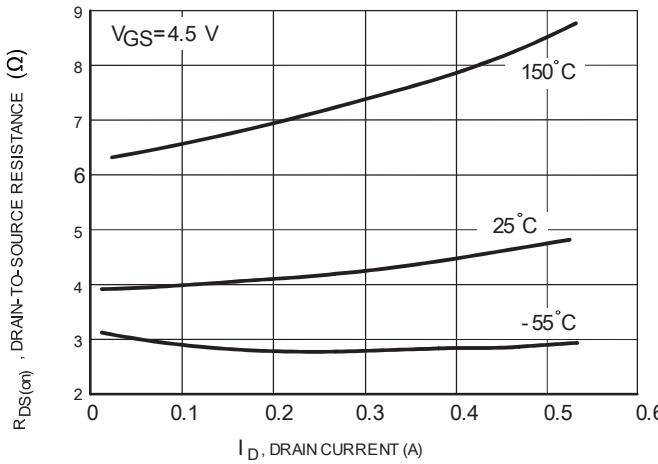

Fig3. On-Resistance versus Drain Current

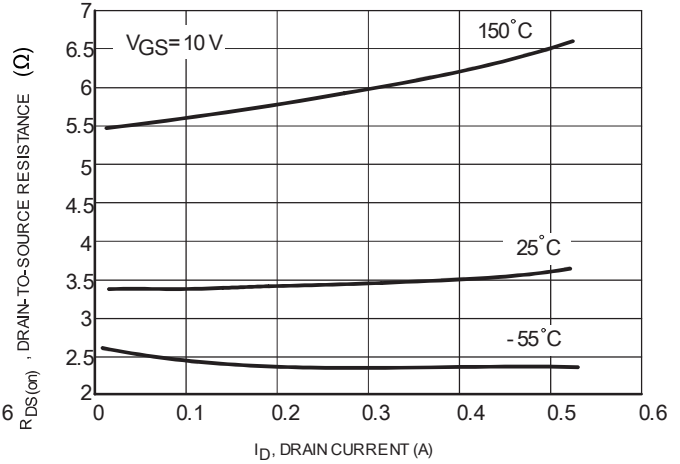

Fig4. On-Resistance versus Drain Current

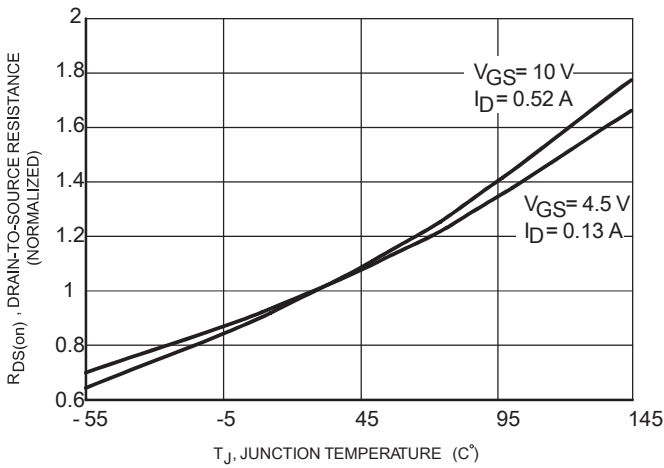

Fig5. On-Resistance Variation with Temperature

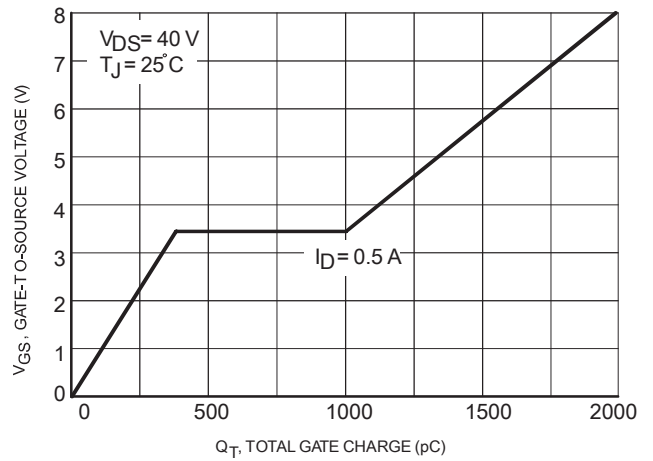
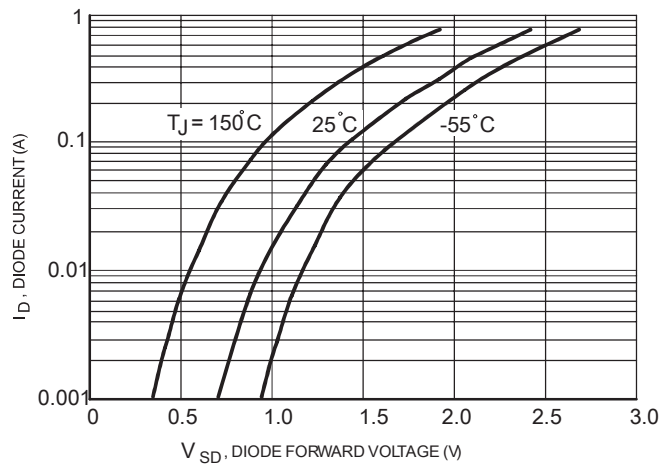
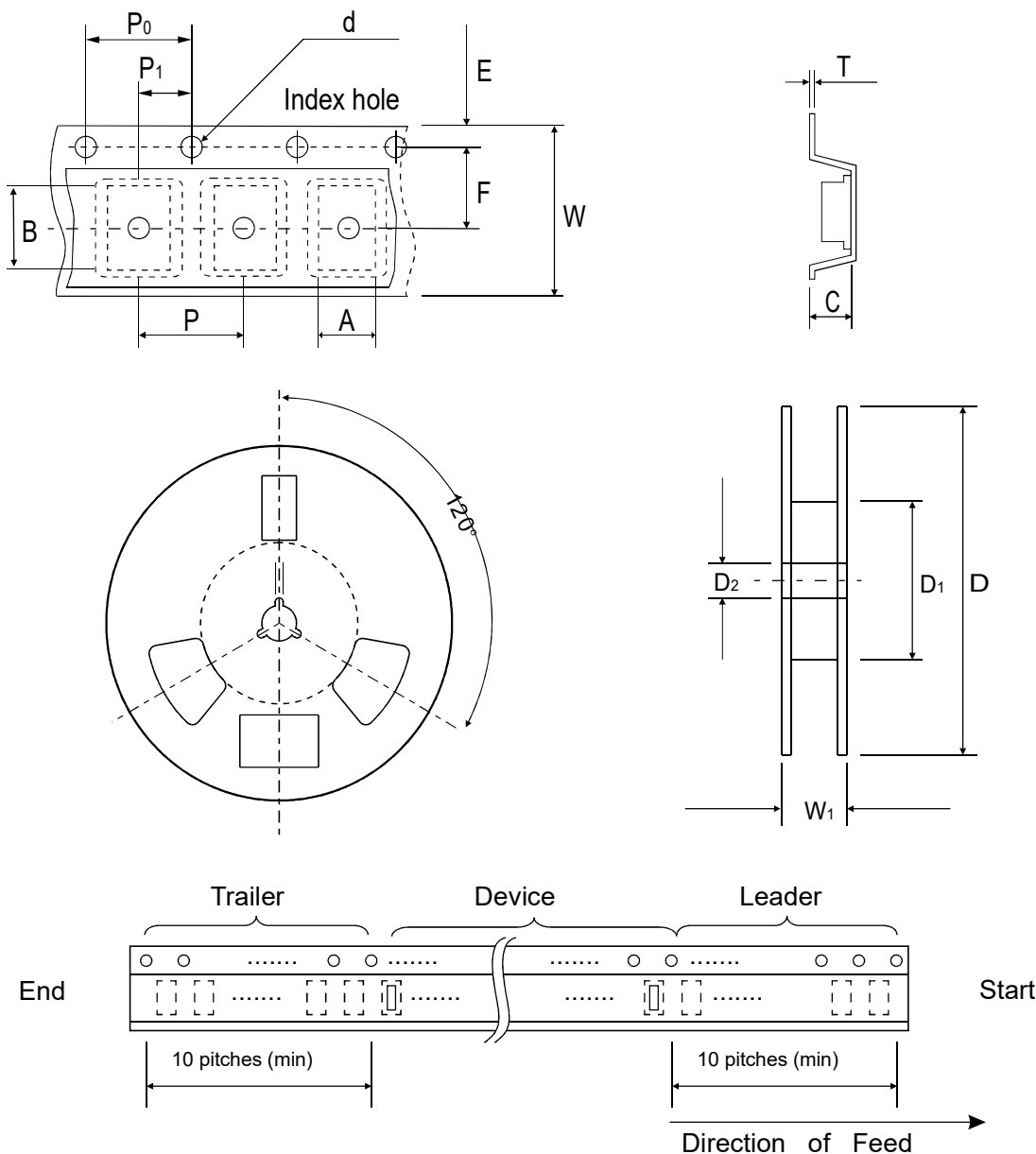

Fig6. Gate Charge



Reel Taping Specification



SOT-23	SYMBOL	A	B	C	d	D	D ₁	D ₂
	(mm)	3.10 ± 0.10	2.85 ± 0.10	1.40 ± 0.10	1.55 ± 0.10	178 ± 1	50.0 MIN.	13.0 ± 0.20
	(inch)	0.122 ± 0.004	0.112 ± 0.004	0.055 ± 0.004	0.061 ± 0.004	7.008 ± 0.04	1.969 MIN.	0.512 ± 0.008

SOT-23	SYMBOL	E	F	P	P ₀	P ₁	W	W ₁
	(mm)	1.75 ± 0.10	3.50 ± 0.05	4.00 ± 0.10	4.00 ± 0.10	2.00 ± 0.05	8.00 ± 0.30	14.4 MAX.
	(inch)	0.069 ± 0.004	0.138 ± 0.002	0.157 ± 0.004	0.157 ± 0.004	0.079 ± 0.002	0.315 ± 0.012	0.567 MAX.

Company reserves the right to improve product design, functions and reliability without notice.

REV:A

Marking Code

Part Number	Marking Code
BSS84-HF	PD

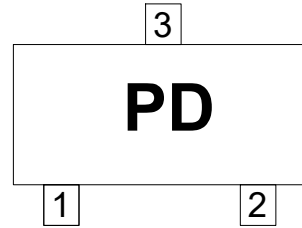

Suggested PAD Layout

SIZE	SOT-23	
	(mm)	(inch)
A	0.80	0.031
B	1.90	0.075
C	2.02	0.080
D	2.82	0.111

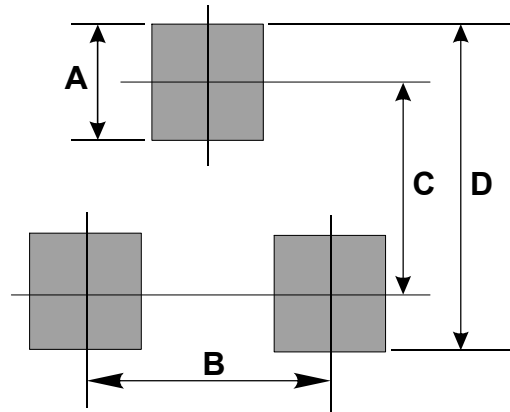



Standard Packaging





Case Type	Qty per Reel	Reel Size
	(Pcs)	(inch)
SOT-23	3000	7

Looking for pricing, stock, or lifecycle information?

Click below to explore more details on WIN SOURCE:

-  [View BSS84-HF on WIN SOURCE](#)
-  [Comchip Technology Information](#)

Optimize Your Supply Chain with WIN SOURCE Solutions

-  Global Sourcing Solution
-  Obsolete Management
-  Cost Control Management
-  Shortage Management
-  Alternative Solution
-  Excess Inventory Management