



# THE DATASHEET OF OPA1655DR



# OPA165x Ultra-Low-Noise, Low-Distortion, FET-Input, Burr-Brown™ Audio Operational Amplifiers



## 1 Features

- Ultra-low noise:
  - Voltage noise: 2.9 nV/√Hz at 10 kHz
  - Current noise: 6 fA/√Hz at 1 kHz
- Low distortion:
  - 0.000029% (–131 dB) at 1 kHz
  - 0.000035% (–129 dB) at 20 kHz
- High open-loop gain: 150 dB
- High output current: 100 mA
- Low input bias current: 10 pA
- Slew rate: 24 V/μs
- Gain bandwidth product: 53 MHz
- Rail-to-rail output
- Wide supply range: ±2.25 V to ±18 V or 4.5 V to 36 V
- Quiescent current: 3.9 mA per channel

## 2 Applications

- [Professional microphones and wireless systems](#)
- [Professional audio mixer/control surface](#)
- [Guitar amplifier and other music instrument amplifier](#)
- [A/V receiver](#)
- [Bookshelf stereo system](#)
- [Professional audio amplifier](#)
- [DJ equipment](#)
- [Turntable](#)
- [Special function module](#)

## 3 Description

The OPA1655 and OPA1656 (OPA165x) are Burr-Brown™ op amps designed specifically for audio and industrial applications, where maintaining signal fidelity is crucial. The FET-input architecture achieves a low 2.9-nV/√Hz voltage noise density and 6-fA/√Hz current noise density, allowing for very-low noise performance in a wide variety of circuits. The high bandwidth and high open-loop-gain design of the OPA165x delivers a low distortion of 0.000035% (–129 dB) at 20 kHz, and improves audio signal fidelity across the full audio bandwidth. These devices also feature excellent output current drive capability, offering rail-to-rail output swing to within 250 mV of the power supplies with a 2-kΩ load, and can deliver 100 mA of output current.

The OPA165x operate over a very wide supply range of ±2.25 V to ±18 V or (4.5 V to 36 V) on 3.9 mA of supply current to accommodate the power-supply constraints of many types of audio products. The temperature range is specified from –40°C to +125°C.

### Device Information

PART NUMBER	CHANNEL	PACKAGE <sup>(1)</sup>
OPA1655	Single	D (SOIC, 8)
		DBV (SOT-23, 5)
OPA1656	Dual	D (SOIC, (8)

- (1) For all available packages, see the package option addendum at the end of the data sheet.

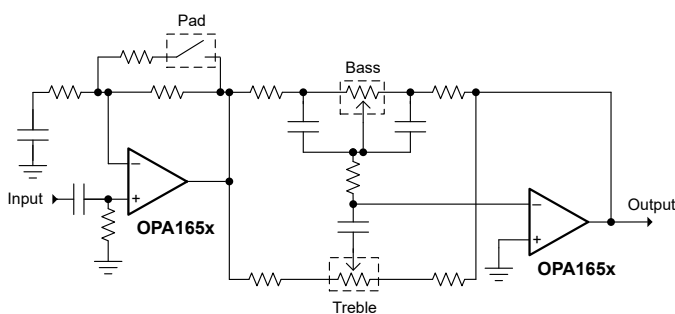

Active Baxandall Tone Control

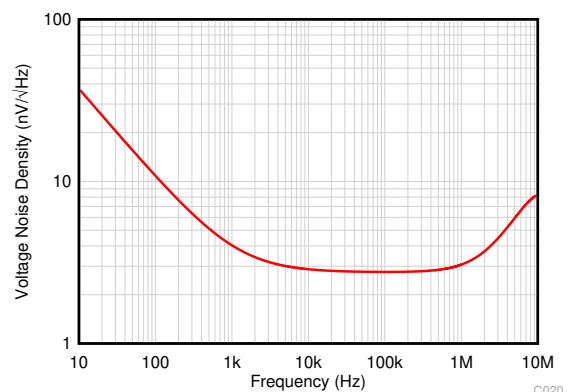

Ultra-Low Input Voltage Noise



## Table of Contents

<b>1 Features</b> .....	1	7.4 Device Functional Modes.....	18
<b>2 Applications</b> .....	1	<b>8 Application and Implementation</b> .....	19
<b>3 Description</b> .....	1	8.1 Application Information.....	19
<b>4 Revision History</b> .....	2	8.2 Typical Applications.....	20
<b>5 Pin Configuration and Functions</b> .....	3	8.3 Power Supply Recommendations.....	27
<b>6 Specifications</b> .....	4	8.4 Layout.....	27
6.1 Absolute Maximum Ratings.....	4	<b>9 Device and Documentation Support</b> .....	29
6.2 ESD Ratings.....	4	9.1 Device Support.....	29
6.3 Recommended Operating Conditions.....	4	9.2 Documentation Support.....	30
6.4 Thermal Information: OPA1655.....	5	9.3 Receiving Notification of Documentation Updates.....	30
6.5 Thermal Information: OPA1656.....	5	9.4 Support Resources.....	30
6.6 Electrical Characteristics.....	6	9.5 Trademarks.....	30
6.7 Typical Characteristics.....	8	9.6 Electrostatic Discharge Caution.....	30
<b>7 Detailed Description</b> .....	15	9.7 Glossary.....	30
7.1 Overview.....	15	<b>10 Mechanical, Packaging, and Orderable Information</b> .....	30
7.2 Functional Block Diagram.....	15		
7.3 Feature Description.....	15		

## 4 Revision History

NOTE: Page numbers for previous revisions may differ from page numbers in the current version.

<b>Changes from Revision B (December 2021) to Revision C (September 2022)</b>	<b>Page</b>
• Changed OPA1655 DBV (SOT-23, 5) package from preview to production data (active).....	1
<b>Changes from Revision A (July 2019) to Revision B (December 2021)</b>	<b>Page</b>
• Added OPA1655 production data (active) device and associated content.....	1
<b>Changes from Revision * (March 2019) to Revision A (July 2019)</b>	<b>Page</b>
• Changed device status from advanced information (preview) to production data (active).....	1

### 5 Pin Configuration and Functions

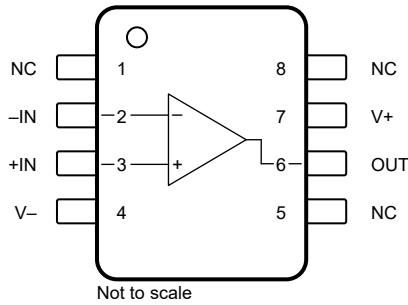

**Figure 5-1. OPA1655 D (8-Pin SOIC) Package, Top View**

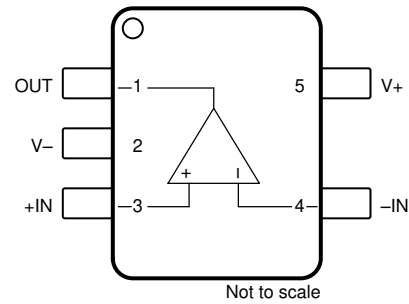

**Figure 5-2. OPA1655 DBV (5-Pin SOT-23) Package, Top View**

#### Pin Functions: OPA1655

NAME	PIN NO.		TYPE	DESCRIPTION
	D (SOIC)	DBV (SOT-23)		
-IN	2	4	Input	Inverting input
+IN	3	3	Input	Noninverting input
OUT	6	1	Output	Output
V-	4	2	Power	Negative (lowest) power supply
V+	7	5	Power	Positive (highest) power supply

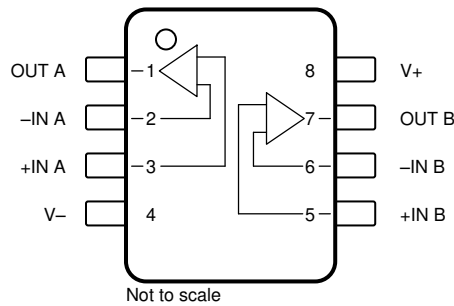

**Figure 5-3. OPA1656 D (8-Pin SOIC) Package, Top View**

#### Pin Functions: OPA1656

NAME	PIN NO.		TYPE	DESCRIPTION
	D (SOIC)	DBV (SOT-23)		
-IN A	2	4	Input	Inverting input, channel A
+IN A	3	3	Input	Noninverting input, channel A
-IN B	6	4	Input	Inverting input, channel B
+IN B	5	3	Input	Noninverting input, channel B
OUT A	1	1	Output	Output, channel A
OUT B	7	1	Output	Output, channel B
V-	4	2	Power	Negative (lowest) power supply
V+	8	5	Power	Positive (highest) power supply

## 6 Specifications

### 6.1 Absolute Maximum Ratings

over operating free-air temperature range (unless otherwise noted)<sup>(1)</sup>

		MIN	MAX	UNIT
Voltage	Supply voltage, $V_S = (V+) - (V-)$		40	V
	Input	$(V-) - 0.5$	$(V+) + 0.5$	V
Current	Input (all pins except power-supply pins)	-10	10	mA
	Output short-circuit <sup>(2)</sup>	Continuous		
Temperature	Operating, $T_A$	-55	125	°C
	Junction, $T_J$		150	°C
	Storage, $T_{stg}$	-65	150	°C

- (1) Operation outside the Absolute Maximum Ratings may cause permanent device damage. Absolute Maximum Ratings do not imply functional operation of the device at these or any other conditions beyond those listed under Recommended Operating Conditions. If used outside the Recommended Operating Conditions but within the Absolute Maximum Ratings, the device may not be fully functional, and this may affect device reliability, functionality, performance, and shorten the device lifetime.
- (2) Short-circuit to  $V_S / 2$  (ground/symmetrical dual-supply setups), one amplifier per package.

### 6.2 ESD Ratings

			VALUE	UNIT
$V_{(ESD)}$	Electrostatic discharge	Human-body model (HBM), per ANSI/ESDA/JEDEC JS-001 <sup>(1)</sup>	±2000	V
		Charged-device model (CDM), per JEDEC specification JESD22-C101 <sup>(2)</sup>	±1000	

- (1) JEDEC document JEP155 states that 500-V HBM allows safe manufacturing with a standard ESD control process.
- (2) JEDEC document JEP157 states that 250-V CDM allows safe manufacturing with a standard ESD control process.

### 6.3 Recommended Operating Conditions

over operating free-air temperature range (unless otherwise noted)

			MIN	NOM	MAX	UNIT
$V_S$	Supply voltage	Single supply	4.5		36	V
		Dual supply	±2.25		±18	
$T_A$	Operating temperature		-40		125	°C

## 6.4 Thermal Information: OPA1655

THERMAL METRIC <sup>(1)</sup>		OPA1655		UNIT
		D (SOIC)	DBV (SOT23)	
		8 PINS	5 PINS	
$R_{\theta JA}$	Junction-to-ambient thermal resistance	120.9	143.4	°C/W
$R_{\theta JC(top)}$	Junction-to-case (top) thermal resistance	58.9	68.4	°C/W
$R_{\theta JB}$	Junction-to-board thermal resistance	65.1	39.2	°C/W
$\Psi_{JT}$	Junction-to-top characterization parameter	13.5	20.4	°C/W
$\Psi_{JB}$	Junction-to-board characterization parameter	64.2	39.0	°C/W
$R_{\theta JC(bot)}$	Junction-to-case (bottom) thermal resistance	N/A	N/A	°C/W

(1) For more information about traditional and new thermal metrics, see the [Semiconductor and IC Package Thermal Metrics](#) application report.

## 6.5 Thermal Information: OPA1656

THERMAL METRIC <sup>(1)</sup>		OPA1656		UNIT
		D (SOIC)		
		8 PINS		
$R_{\theta JA}$	Junction-to-ambient thermal resistance	119.9		°C/W
$R_{\theta JC(top)}$	Junction-to-case (top) thermal resistance	51.8		°C/W
$R_{\theta JB}$	Junction-to-board thermal resistance	65.4		°C/W
$\Psi_{JT}$	Junction-to-top characterization parameter	10.0		°C/W
$\Psi_{JB}$	Junction-to-board characterization parameter	64.2		°C/W
$R_{\theta JC(bot)}$	Junction-to-case (bottom) thermal resistance	N/A		°C/W

(1) For more information about traditional and new thermal metrics, see the [Semiconductor and IC Package Thermal Metrics](#) application report.

## 6.6 Electrical Characteristics

at  $T_A = 25^\circ\text{C}$ ,  $V_S = \pm 18\text{ V}$ ,  $R_L = 2\text{ k}\Omega$ , and  $V_{CM} = V_{OUT} = V_S/2$  (unless otherwise noted)

PARAMETER		TEST CONDITIONS		MIN	TYP	MAX	UNIT
<b>AUDIO PERFORMANCE</b>							
THD+N	Total harmonic distortion + noise	G = 1, $R_L = 600\ \Omega$ , $V_O = 3.5\ V_{RMS}$ , f = 1 kHz, 80-kHz measurement bandwidth		0.000029%			
		G = 1, $R_L = 600\ \Omega$ , $V_O = 3.5\ V_{RMS}$ , f = 20 kHz, 80-kHz measurement bandwidth		–131			dB
		G = 1, $R_L = 600\ \Omega$ , $V_O = 3.5\ V_{RMS}$ , f = 1 kHz, 80-kHz measurement bandwidth		0.0001%			
		G = 1, $R_L = 600\ \Omega$ , $V_O = 3.5\ V_{RMS}$ , f = 20 kHz, 80-kHz measurement bandwidth		–120			dB
THD+N	Total harmonic distortion + noise	G = 1, $R_L = 2\text{ k}\Omega$ , $V_O = 3.5\ V_{RMS}$ , f = 1 kHz, 80-kHz measurement bandwidth		0.000029%			
		G = 1, $R_L = 2\text{ k}\Omega$ , $V_O = 3.5\ V_{RMS}$ , f = 1 kHz, 80-kHz measurement bandwidth		–131			dB
		G = 1, $R_L = 2\text{ k}\Omega$ , $V_O = 3.5\ V_{RMS}$ , f = 20 kHz, 80-kHz measurement bandwidth		0.000035%			
		G = 1, $R_L = 2\text{ k}\Omega$ , $V_O = 3.5\ V_{RMS}$ , f = 20 kHz, 80-kHz measurement bandwidth		–129			dB
IMD	Intermodulation distortion	G = 1 $V_O = 3.5\ V_{RMS}$	SMPTE/DIN two-tone, 4:1 (60 Hz and 7 kHz)	0.000018%			
			CCIF twin-tone (19 kHz and 20 kHz)	–135			dB
				0.000020%			
				–134			dB
<b>FREQUENCY RESPONSE</b>							
GBW	Gain-bandwidth product	G = 100			53		MHz
	Unity gain bandwidth	G = 1			20		MHz
SR	Slew rate	G = –1, 10-V step			24		V/ $\mu\text{s}$
	Full-power bandwidth <sup>(1)</sup>	$V_O = 1\ V_P$			3.8		MHz
	Overload recovery time	G = –10			100		ns
	Channel separation	f = 1 kHz			–135		dB
	Settling time	0.01%, G = –1, 10-V step			800		ns
<b>NOISE</b>							
	Input voltage noise	f = 20 Hz to 20 kHz			0.53		$\mu\text{V}_{RMS}$
		f = 0.1 Hz to 10 Hz			1.9		$\mu\text{V}_{PP}$
$e_n$	Input voltage noise density	f = 100 Hz			11.8		nV/ $\sqrt{\text{Hz}}$
		f = 1 kHz			4.3		nV/ $\sqrt{\text{Hz}}$
		f = 10 kHz			2.9		nV/ $\sqrt{\text{Hz}}$
$i_n$	Input current noise density	f = 1 kHz			6		fA/ $\sqrt{\text{Hz}}$
<b>OFFSET VOLTAGE</b>							
$V_{OS}$	Input offset voltage	$V_S = \pm 2.25\text{ V to } \pm 18\text{ V}$			$\pm 0.5$	$\pm 1$	mV
$dV_{OS}/dT$	Input offset voltage drift <sup>(2)</sup>	$V_S = \pm 2.25\text{ V to } \pm 18\text{ V}$ $T_A = -40^\circ\text{C to } +125^\circ\text{C}$			0.3	2	$\mu\text{V}/^\circ\text{C}$
PSRR	Power-supply rejection ratio	$V_S = \pm 2.25\text{ V to } \pm 18\text{ V}$			0.3	5	$\mu\text{V}/\text{V}$
<b>INPUT BIAS CURRENT</b>							
$I_B$	Input bias current <sup>(3)</sup>	$V_{CM} = 0\text{ V}$	OPA1655		$\pm 10$		pA
			OPA1656		$\pm 10$	$\pm 20$	
$I_{OS}$	Input offset current	$V_{CM} = 0\text{ V}$	OPA1655		$\pm 10$		pA
			OPA1656		$\pm 10$	$\pm 20$	
<b>INPUT VOLTAGE RANGE</b>							
$V_{CM}$	Common-mode voltage range			(V–)	(V+) – 2.25		V
CMRR	Common-mode rejection ratio	$(V–) \leq V_{CM} \leq (V+) - 2.25$		106	120		dB
<b>INPUT IMPEDANCE</b>							
	Differential				100    9.1		M $\Omega$    pF
	Common-mode				6    1.9		$10^{12}\ \Omega$    pF
<b>OPEN-LOOP GAIN</b>							
$A_{OL}$	Open-loop voltage gain	$(V–) + 1.3\text{ V} \leq V_O \leq (V+) - 1.3\text{ V}$ $R_L = 600\ \Omega$		134	150		dB
		$(V–) + 0.5\text{ V} \leq V_O \leq (V+) - 0.5\text{ V}$ $R_L = 2\text{ k}\Omega$		134	154		

## 6.6 Electrical Characteristics (continued)

at  $T_A = 25^\circ\text{C}$ ,  $V_S = \pm 18\text{ V}$ ,  $R_L = 2\text{ k}\Omega$ , and  $V_{CM} = V_{OUT} = V_S/2$  (unless otherwise noted)

PARAMETER		TEST CONDITIONS	MIN	TYP	MAX	UNIT
<b>OUTPUT</b>						
$V_O$	Voltage output		(V-) + 0.25	(V+) – 0.25		V
$Z_O$	Open-loop output impedance	$f = 1\text{ MHz}$		26		$\Omega$
$I_{SC}$	Short-circuit current <sup>(4)</sup>			$\pm 100$		mA
$C_L$	Capacitive load drive			100		pF
<b>POWER SUPPLY</b>						
$I_Q$	Quiescent current (per channel)	$I_O = 0\text{ A}$ , $V_S = \pm 2.25\text{ V}$ to $\pm 18\text{ V}$		3.9	4.6	mA
		$I_O = 0\text{ A}$ , $T_A = -40^\circ\text{C}$ to $+125^\circ\text{C}$ <sup>(2)</sup>			5.0	

- (1) Full-power bandwidth =  $SR / (2\pi \times V_P)$ , where SR = slew rate.
- (2) Specified by design and characterization.
- (3) Input bias current test conditions can vary from nominal ambient conditions as a result of junction temperature differences.
- (4) One channel at a time.

## 6.7 Typical Characteristics

at  $T_A = 25^\circ\text{C}$ ,  $V_S = \pm 15\text{ V}$ ,  $R_L = 2\text{ k}\Omega$ , and  $V_{CM} = V_S/2$  (unless otherwise noted)

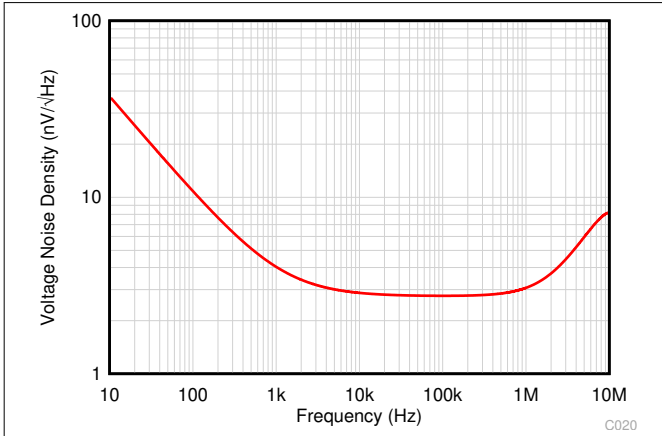

Figure 6-1. Input Voltage Noise Density vs Frequency

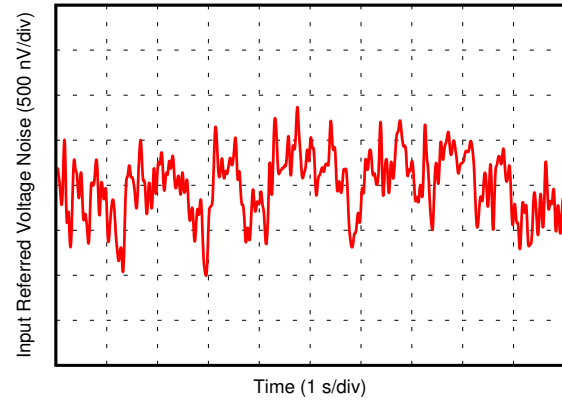

Figure 6-2. 0.1-Hz to 10-Hz Noise

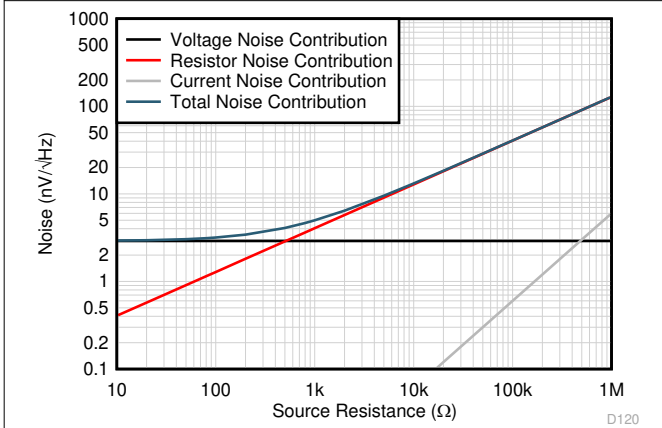

Figure 6-3. Voltage Noise vs Source Resistance

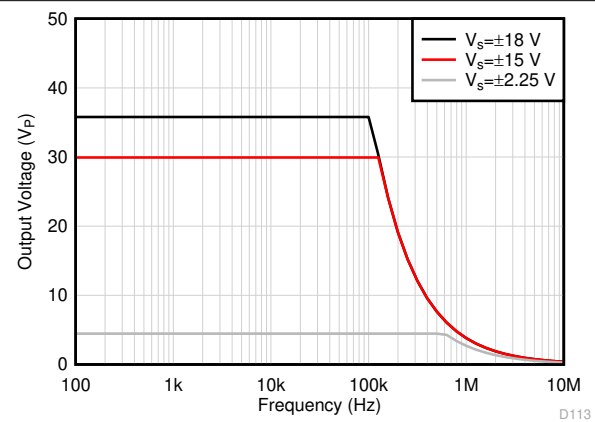

Figure 6-4. Maximum Output Voltage vs Frequency

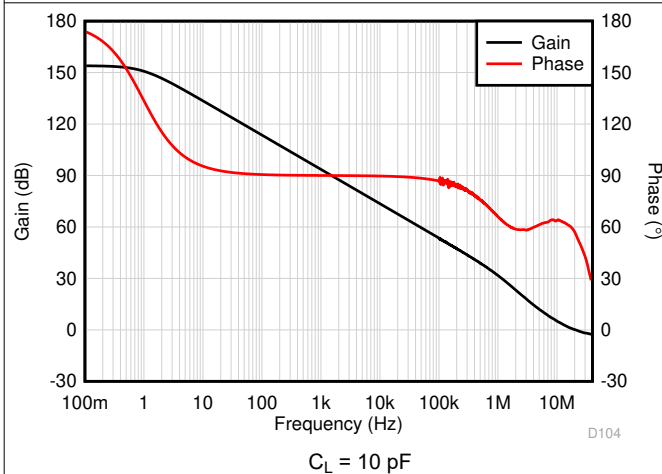

Figure 6-5. Open-Loop Gain and Phase vs Frequency

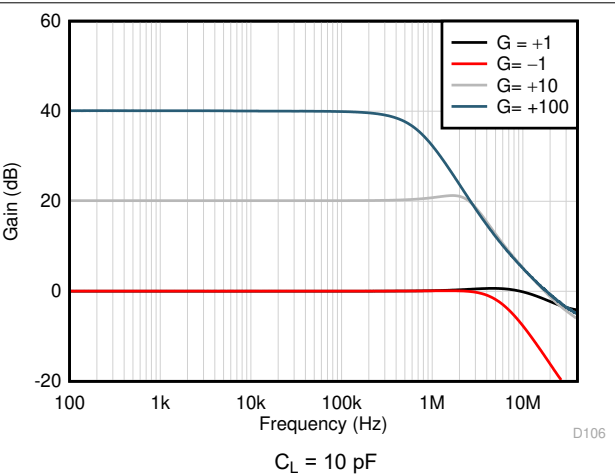
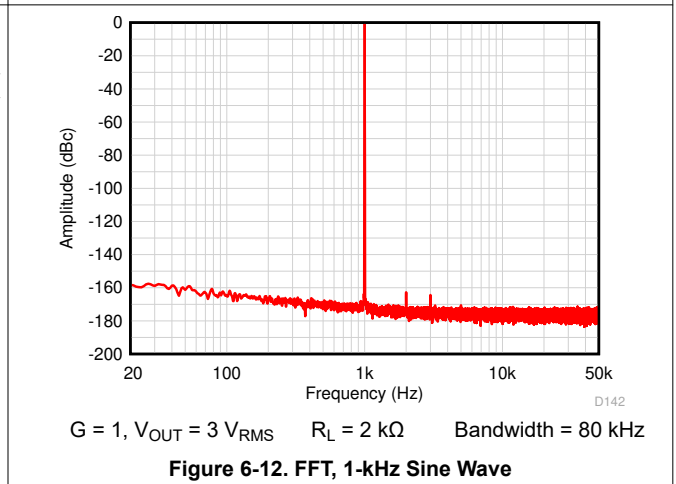
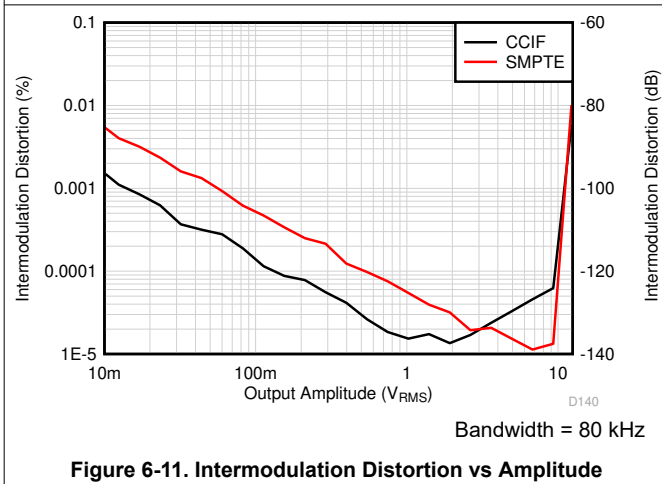
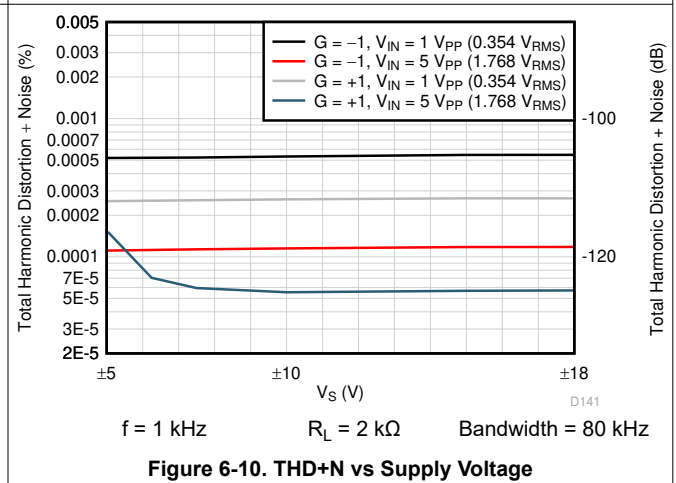
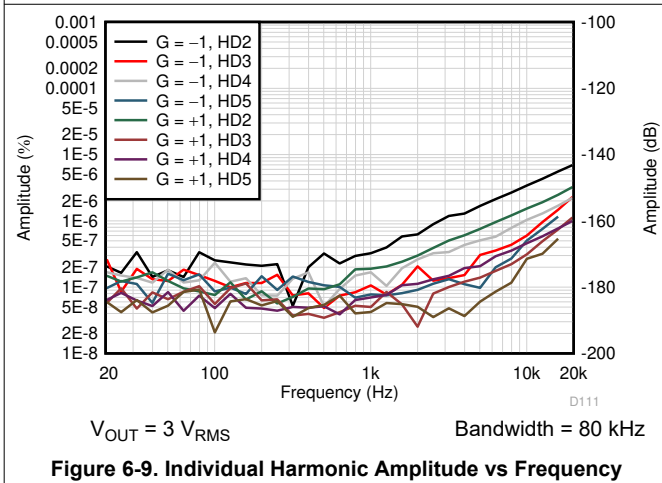
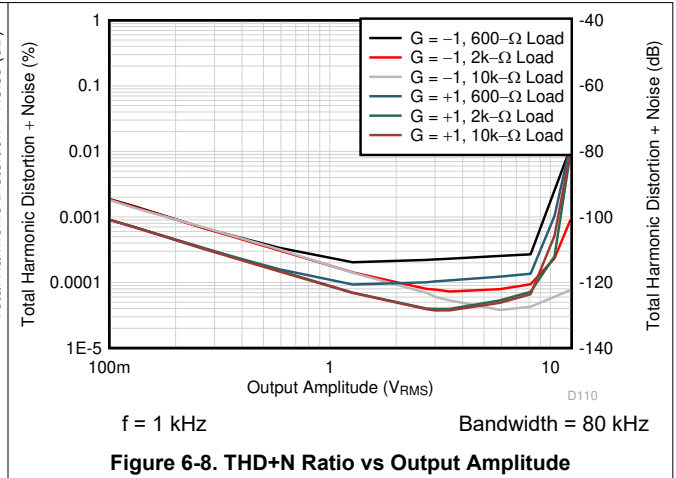
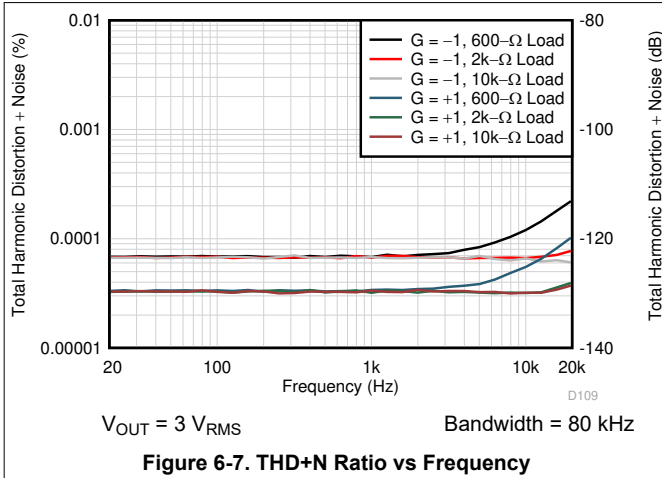

Figure 6-6. Closed-Loop Gain vs Frequency

### 6.7 Typical Characteristics (continued)

at  $T_A = 25^\circ\text{C}$ ,  $V_S = \pm 15\text{ V}$ ,  $R_L = 2\text{ k}\Omega$ , and  $V_{CM} = V_S/2$  (unless otherwise noted)



### 6.7 Typical Characteristics (continued)

at  $T_A = 25^\circ\text{C}$ ,  $V_S = \pm 15\text{ V}$ ,  $R_L = 2\text{ k}\Omega$ , and  $V_{CM} = V_S/2$  (unless otherwise noted)

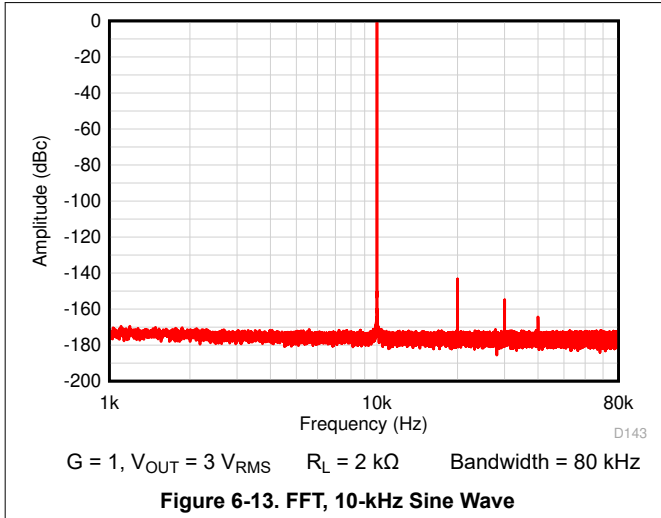

Figure 6-13. FFT, 10-kHz Sine Wave

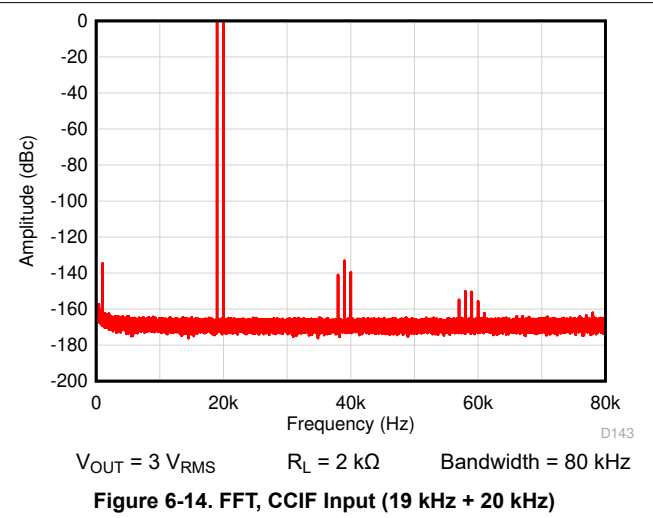

Figure 6-14. FFT, CCIF Input (19 kHz + 20 kHz)

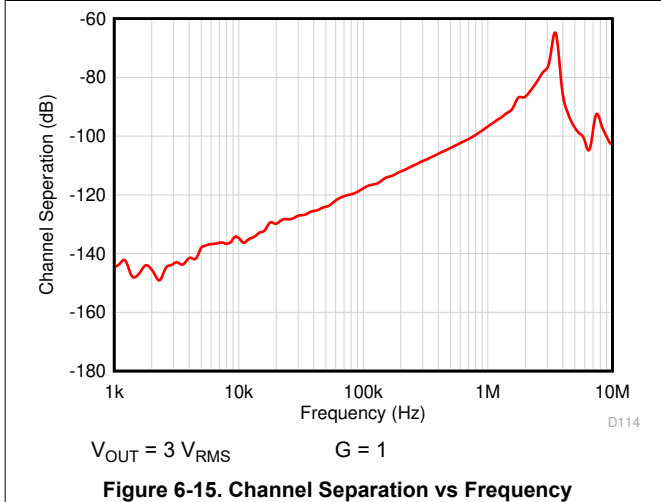

Figure 6-15. Channel Separation vs Frequency

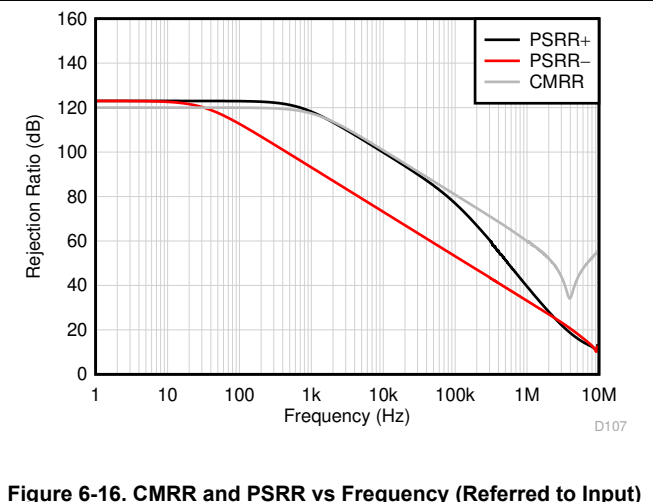

Figure 6-16. CMRR and PSRR vs Frequency (Referred to Input)

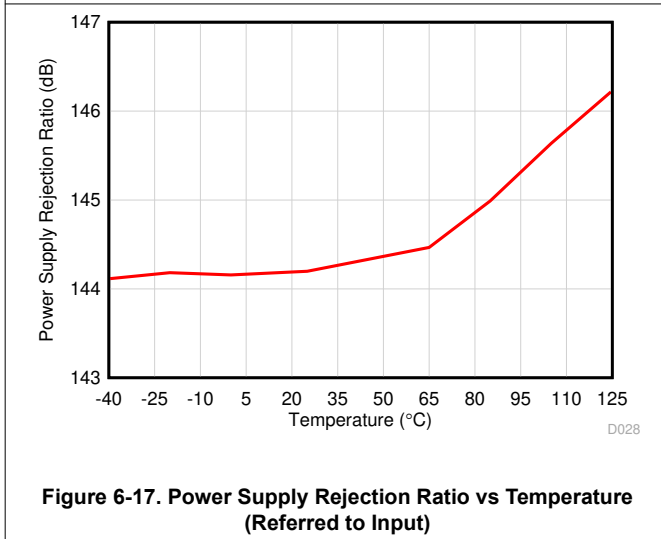

Figure 6-17. Power Supply Rejection Ratio vs Temperature (Referred to Input)

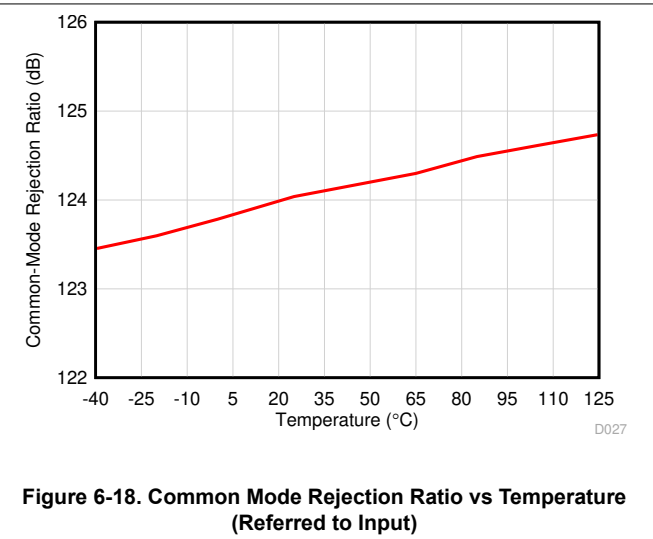

Figure 6-18. Common Mode Rejection Ratio vs Temperature (Referred to Input)

### 6.7 Typical Characteristics (continued)

at  $T_A = 25^\circ\text{C}$ ,  $V_S = \pm 15\text{ V}$ ,  $R_L = 2\text{ k}\Omega$ , and  $V_{CM} = V_S/2$  (unless otherwise noted)

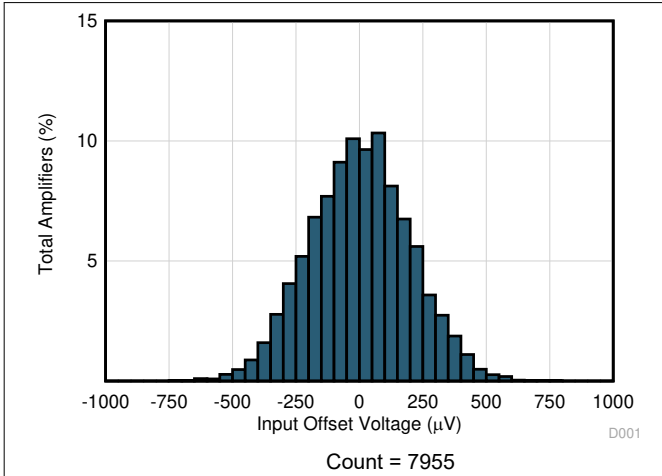

Figure 6-19. Input Offset Voltage Distribution

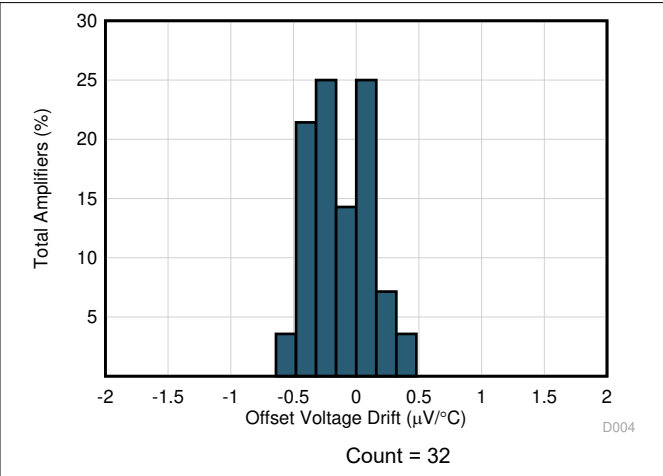

Figure 6-20. Input Offset Voltage Drift Distribution

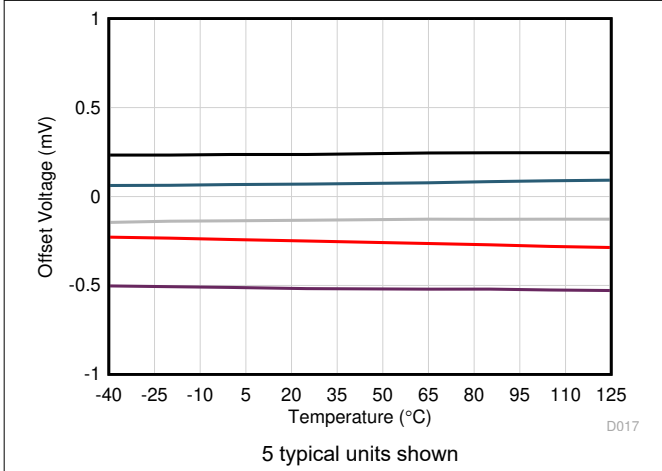

Figure 6-21. Input Offset vs Temperature

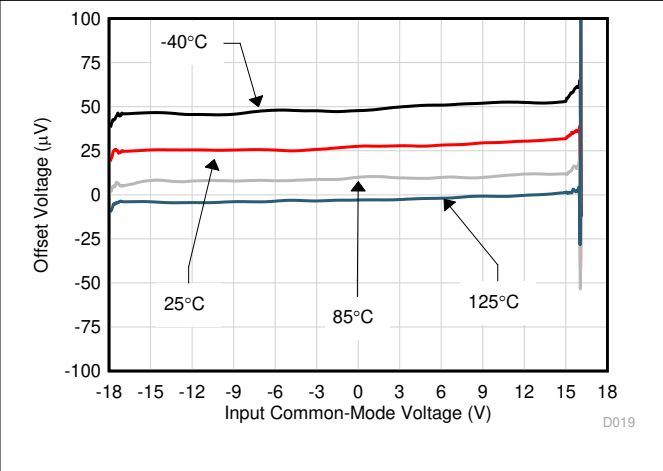

Figure 6-22. Input Offset vs Common Mode Voltage

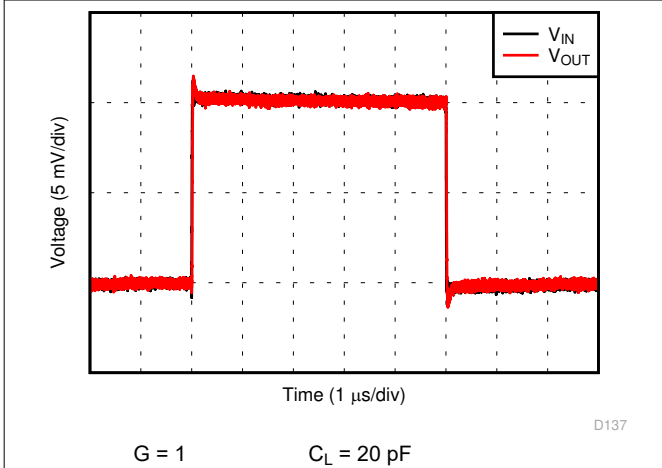

Figure 6-23. Small-Signal Step Response (100 mV)

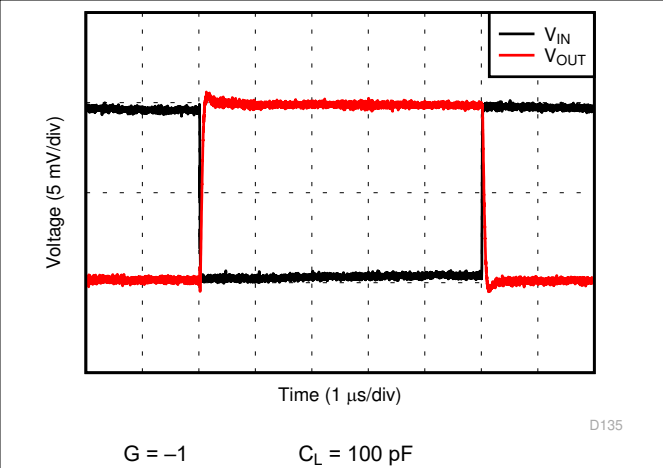
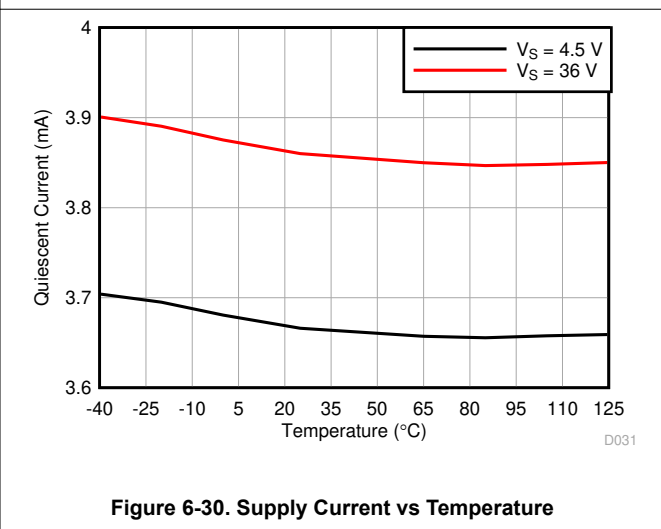
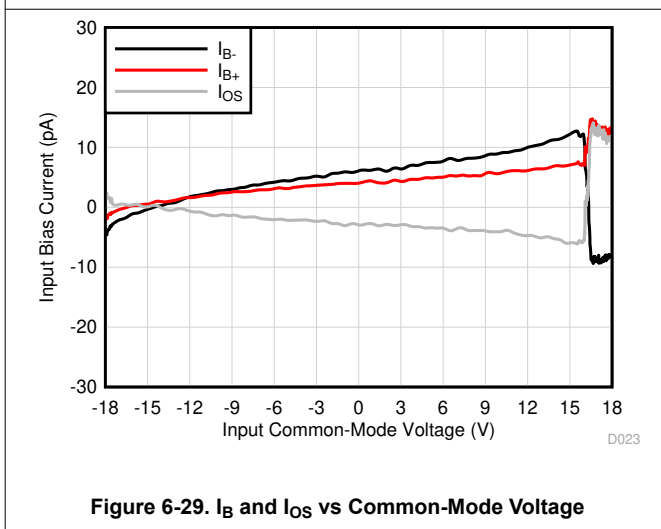
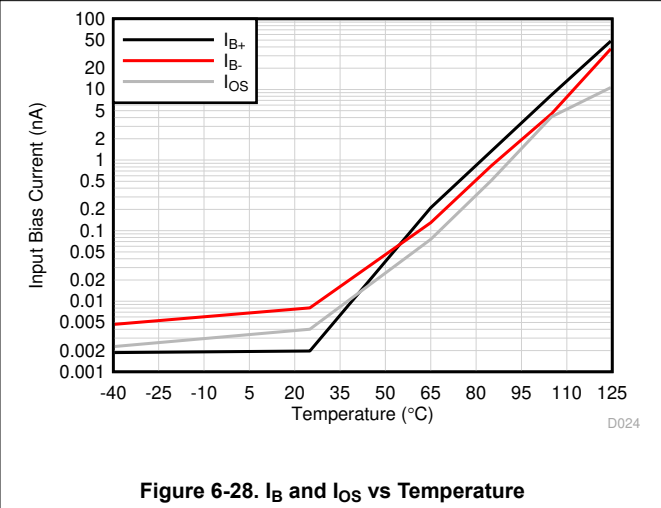
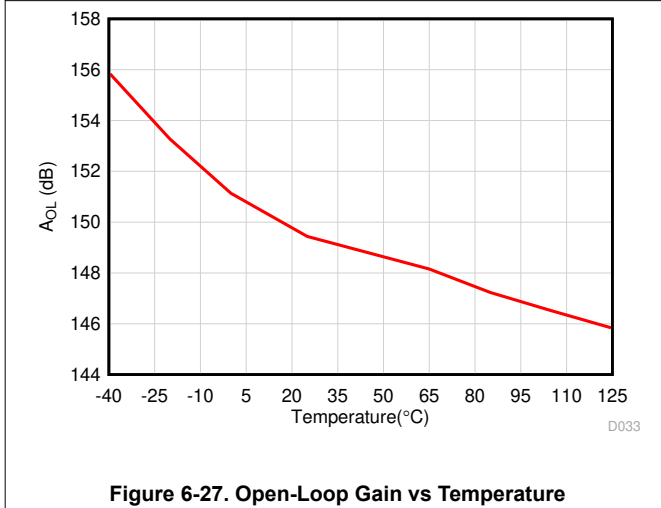
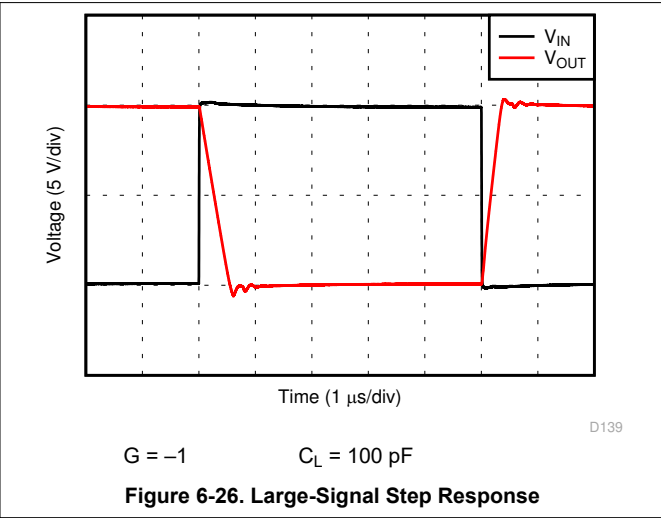
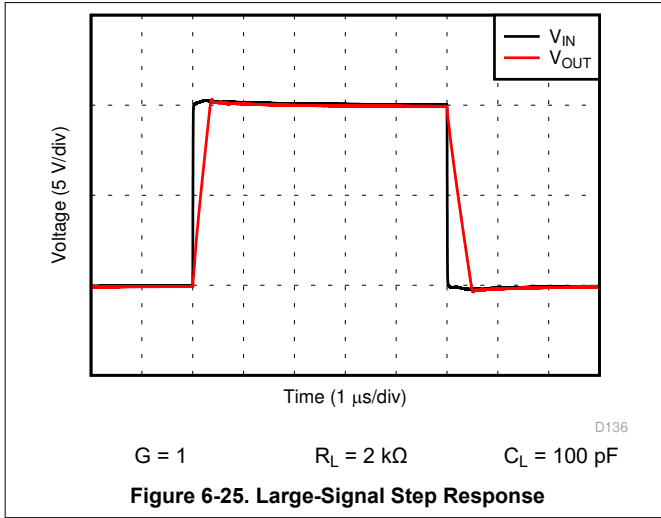

Figure 6-24. Small-Signal Step Response (100 mV)

### 6.7 Typical Characteristics (continued)

at  $T_A = 25^\circ\text{C}$ ,  $V_S = \pm 15\text{ V}$ ,  $R_L = 2\text{ k}\Omega$ , and  $V_{CM} = V_S/2$  (unless otherwise noted)



### 6.7 Typical Characteristics (continued)

at  $T_A = 25^\circ\text{C}$ ,  $V_S = \pm 15\text{ V}$ ,  $R_L = 2\text{ k}\Omega$ , and  $V_{CM} = V_S/2$  (unless otherwise noted)

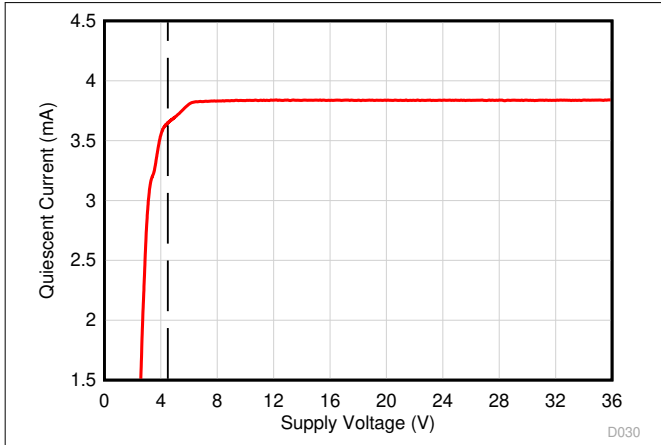

Figure 6-31. Supply Current vs Supply Voltage

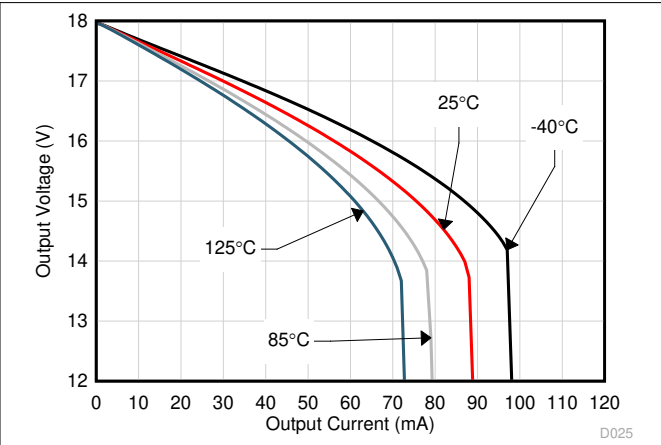

Figure 6-32. Output Voltage vs Output Current (Sourcing)

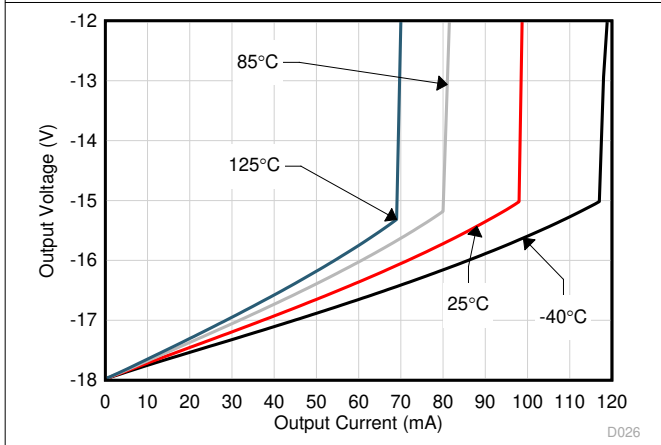

Figure 6-33. Output Voltage vs Output Current (Sinking)

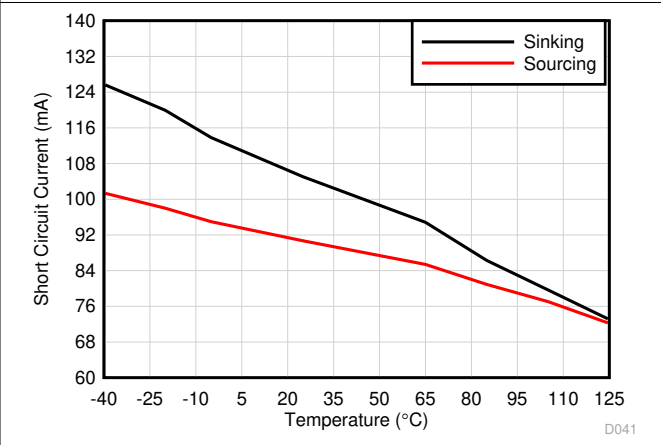

Figure 6-34. Short-Circuit Current vs Temperature

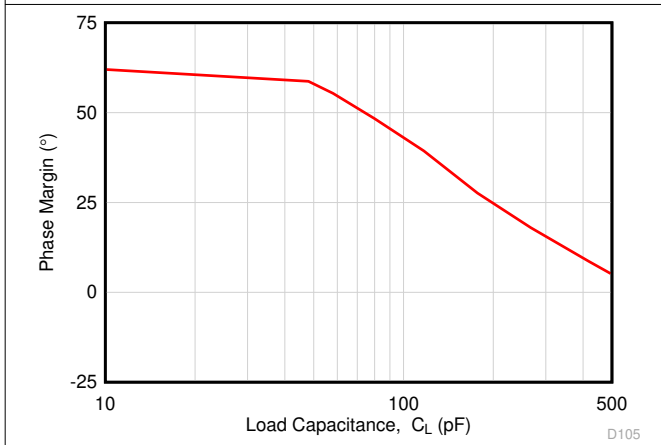

Figure 6-35. Phase Margin vs Capacitive Load

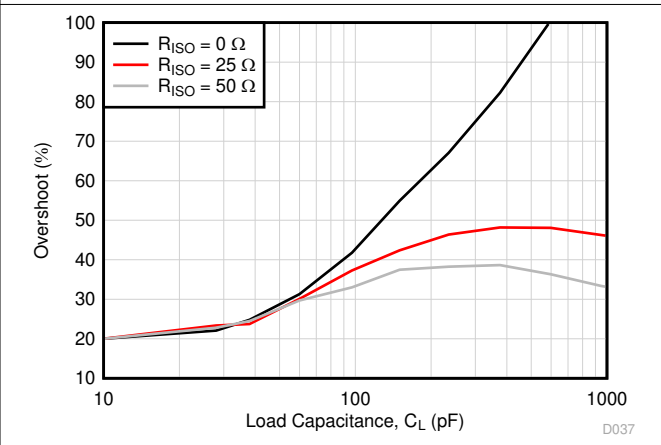

Figure 6-36. Percent Overshoot vs Capacitive Load

### 6.7 Typical Characteristics (continued)

at  $T_A = 25^\circ\text{C}$ ,  $V_S = \pm 15\text{ V}$ ,  $R_L = 2\text{ k}\Omega$ , and  $V_{CM} = V_S/2$  (unless otherwise noted)

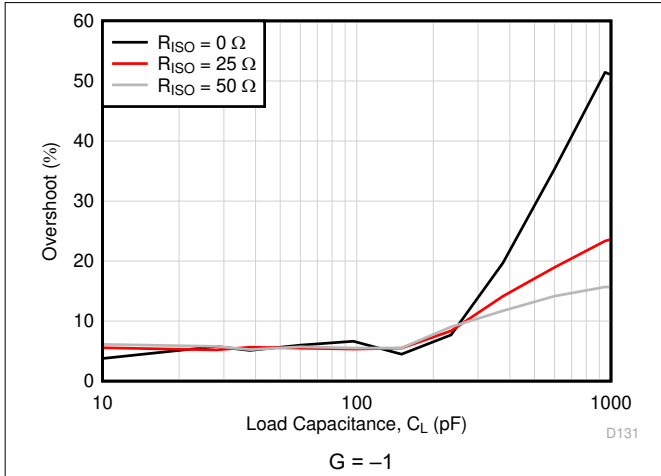

Figure 6-37. Percent Overshoot vs Capacitive Load

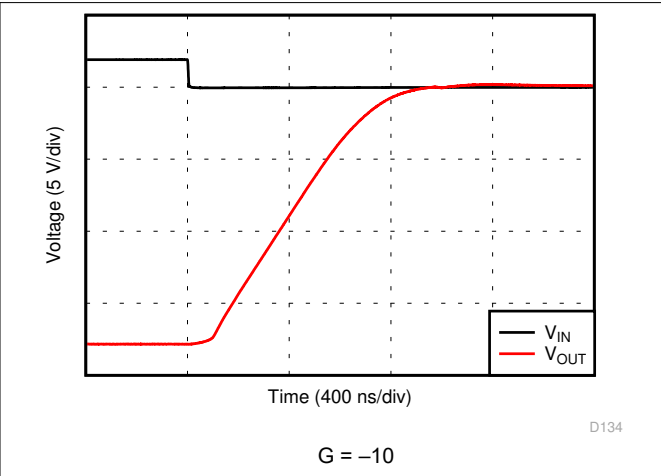

Figure 6-38. Negative Overload Recovery

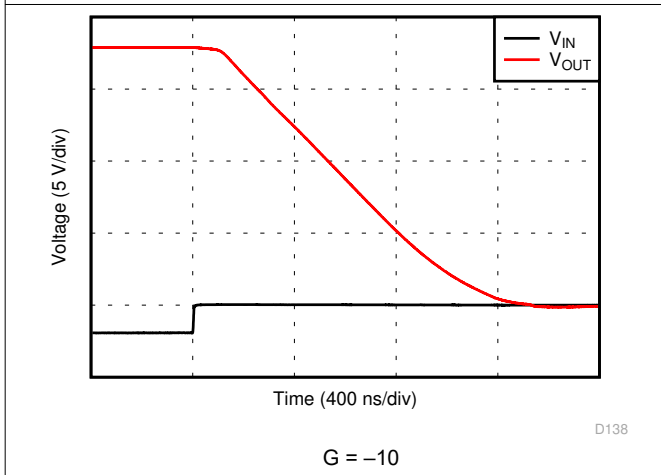

Figure 6-39. Positive Overload Recovery

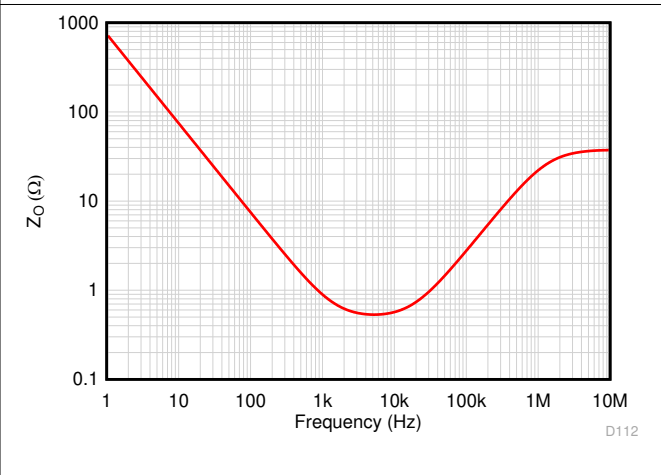

Figure 6-40. Open-Loop Output Impedance vs Frequency

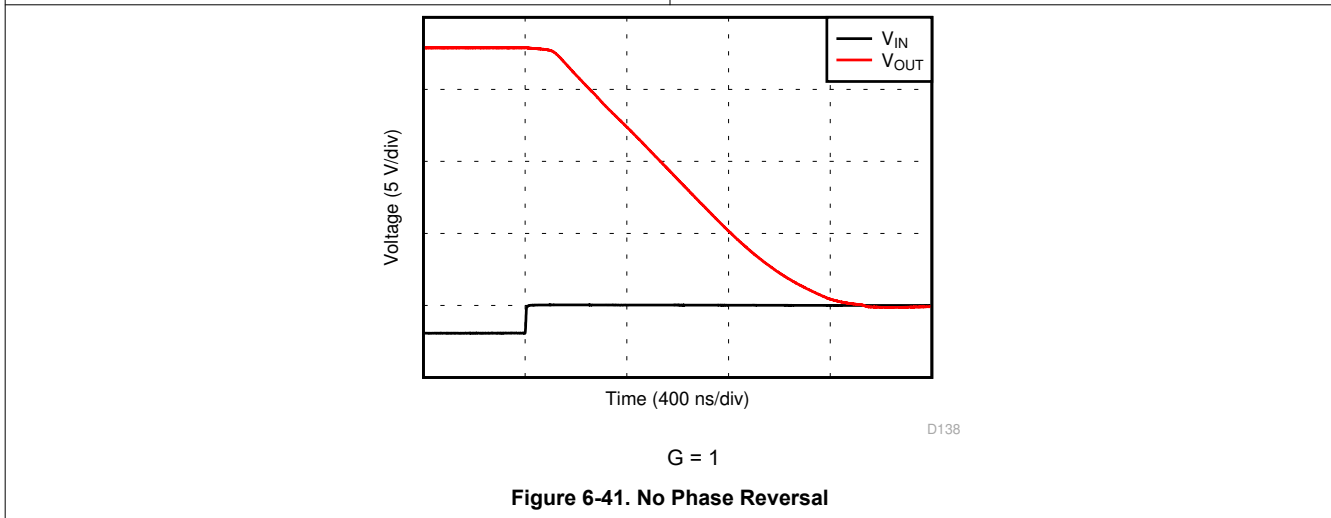

Figure 6-41. No Phase Reversal

## 7 Detailed Description

### 7.1 Overview

The OPA1655 and OPA1656 (OPA165x) use a three-gain-stage architecture to achieve very low noise and distortion. The *Functional Block Diagram* shows a simplified schematic of the OPA165x (one channel shown). The devices consist of a low-noise input stage and feedforward pathway coupled to a high-current output stage. This topology exhibits superior distortion performance under a wide range of loading conditions compared to other operational amplifiers.

### 7.2 Functional Block Diagram

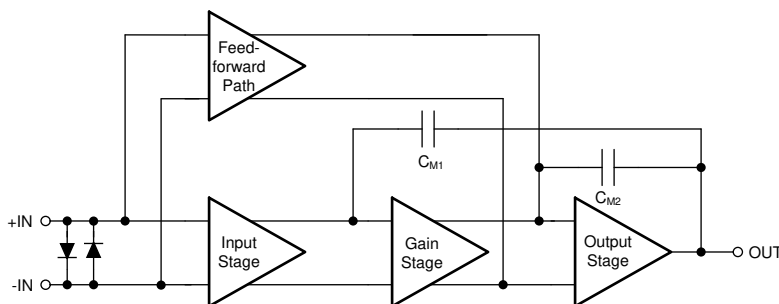

### 7.3 Feature Description

#### 7.3.1 Phase Reversal Protection

The OPA165x have internal phase-reversal protection. Many op amps exhibit phase reversal when the input is driven beyond the linear common-mode range. This condition is most often encountered in noninverting circuits when the input is driven beyond the specified common-mode voltage range, causing the output to reverse into the opposite rail. The input of the OPA165x prevents phase reversal with excessive common-mode voltage. Instead, the appropriate rail limits the output voltage. This performance is shown in [Figure 7-1](#).

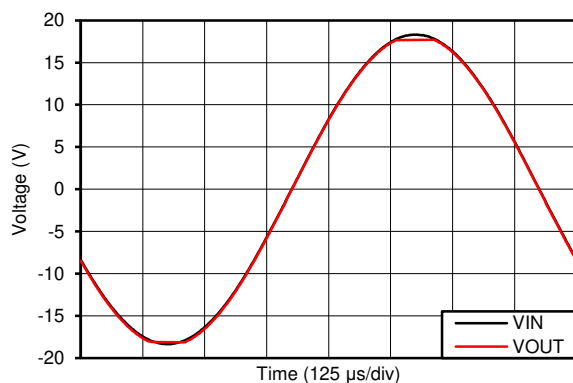
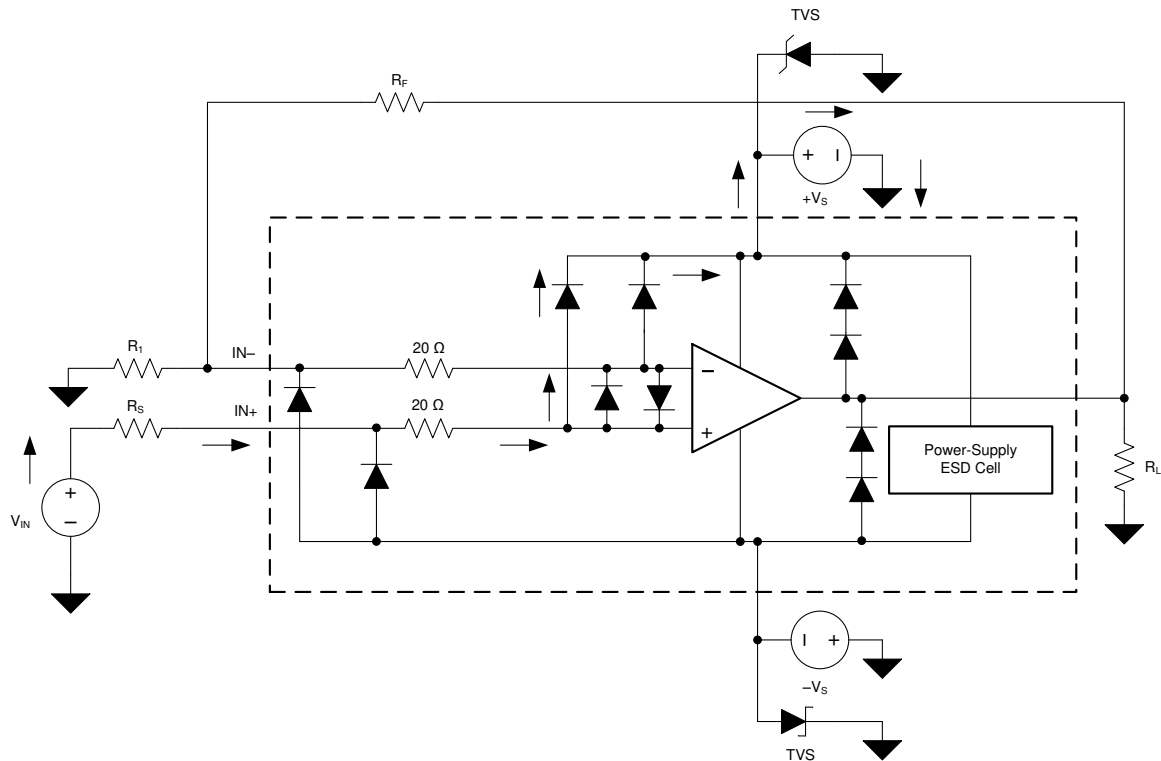

**Figure 7-1. Output Waveform Devoid of Phase Reversal During an Input Overdrive Condition**

#### 7.3.2 Electrical Overstress

Designers often ask questions about the capability of an operational amplifier to withstand electrical overstress. These questions tend to focus on the device inputs, but can involve the supply voltage pins or even the output pin. Each of these different pin functions have electrical stress limits determined by the voltage breakdown characteristics of the particular semiconductor fabrication process and specific circuits connected to the pin. Additionally, internal electrostatic discharge (ESD) protection is built into these circuits to protect them from accidental ESD events both before and during product assembly.

A good understanding of this basic ESD circuitry and the relevance to an electrical overstress event is helpful. Figure 7-2 illustrates the ESD circuits contained in the OPA165x (indicated by the dashed line area). The ESD protection circuitry involves several current-steering diodes connected from the input and output pins and routed back to the internal power-supply lines, where the diodes meet at an absorption device internal to the operational amplifier. This protection circuitry is intended to remain inactive during normal circuit operation.



**Figure 7-2. Equivalent Internal ESD Circuitry Relative to a Typical Circuit Application**

An ESD event produces a short-duration, high-voltage pulse that is transformed into a short-duration, high-current pulse when discharging through a semiconductor device. The ESD protection circuits are designed to provide a current path around the operational amplifier core to prevent damage. The energy absorbed by the protection circuitry is then dissipated as heat.

When an ESD voltage develops across two or more amplifier device pins, current flows through one or more steering diodes. Depending on the path that the current takes, the absorption device can activate. The absorption device has a trigger, or threshold voltage, that is above the normal operating voltage of the OPA165x but below the device breakdown voltage level. When this threshold is exceeded, the absorption device quickly activates and clamps the voltage across the supply rails to a safe level.

When the operational amplifier connects into a circuit, as shown in Figure 7-2, the ESD protection components are intended to remain inactive and do not become involved in the application circuit operation. However, circumstances may arise where an applied voltage exceeds the operating voltage range of a given pin. If this condition occurs, there is a risk that some internal ESD protection circuits can turn on and conduct current. Any such current flow occurs through steering-diode paths and rarely involves the absorption device.

Figure 7-2 shows a specific example where the input voltage ( $V_{IN}$ ) exceeds the positive supply voltage ( $V+$ ) by 500 mV or more. Much of what happens in the circuit depends on the supply characteristics. If  $V+$  can sink the current, one of the upper input steering diodes conducts and directs current to  $V+$ . Excessively high current levels can flow with increasingly higher  $V_{IN}$ . As a result, the data sheet specifications recommend that applications limit the input current to 10 mA.

If the supply is not capable of sinking the current,  $V_{IN}$  can begin sourcing current to the operational amplifier and then take over as the source of positive supply voltage. The danger in this case is that the voltage can rise to levels that exceed the operational amplifier absolute maximum ratings.

Another common question involves what happens to the amplifier if an input signal is applied to the input when the power supplies ( $V+$  or  $V-$ ) are at 0 V. Again, this question depends on the supply characteristic when at 0 V, or at a level below the input signal amplitude. If the supplies appear as high impedance, then the input source supplies the operational amplifier current through the current-steering diodes. This state is not a normal bias condition; most likely, the amplifier does not operate normally. If the supplies are low impedance, then the current through the steering diodes can become quite high. The current level depends on the ability of the input source to deliver current, and any resistance in the input path.

If there is any uncertainty about the ability of the supply to absorb this current, add external Zener diodes to the supply pins; see [Figure 7-2](#). Select the Zener voltage so that the diode does not turn on during normal operation. However, the Zener voltage must be low enough so that the Zener diode conducts if the supply pin begins to rise above the safe-operating, supply-voltage level.

### 7.3.3 EMI Rejection Ratio (EMIRR)

The electromagnetic interference (EMI) rejection ratio, or EMIRR, describes the EMI immunity of operational amplifiers. An adverse effect that is common to many operational amplifiers is a change in the offset voltage as a result of RF signal rectification. An operational amplifier that is more efficient at rejecting this change in offset as a result of EMI has a higher EMIRR and is quantified by a decibel value. Measuring EMIRR can be performed in many ways, but this document provides the EMIRR IN+, which specifically describes the EMIRR performance when the RF signal is applied to the noninverting input pin of the operational amplifier. In general, only the noninverting input is tested for EMIRR for the following three reasons:

- Operational amplifier input pins are known to be the most sensitive to EMI, and typically rectify RF signals better than the supply or output pins.
- The noninverting and inverting operational amplifier inputs have symmetrical physical layouts and exhibit nearly matching EMIRR performance.
- EMIRR is easier to measure on noninverting pins than on other pins because the noninverting input pin can be isolated on a printed-circuit-board (PCB). This isolation allows the RF signal to be applied directly to the noninverting input pin with no complex interactions from other components or connecting PCB traces.

A more formal discussion of the EMIRR IN+ definition and test method is provided in the [EMI Rejection Ratio of Operational Amplifiers application report](#), available for download at [www.ti.com](http://www.ti.com).

The EMIRR IN+ of the OPA165x is plotted versus frequency in [Figure 7-3](#). If available, any dual and quad operational amplifier device versions have nearly identical EMIRR IN+ performance. The OPA165x unity-gain bandwidth is 20 MHz. EMIRR performance below this frequency denotes interfering signals that fall within the operational amplifier bandwidth.

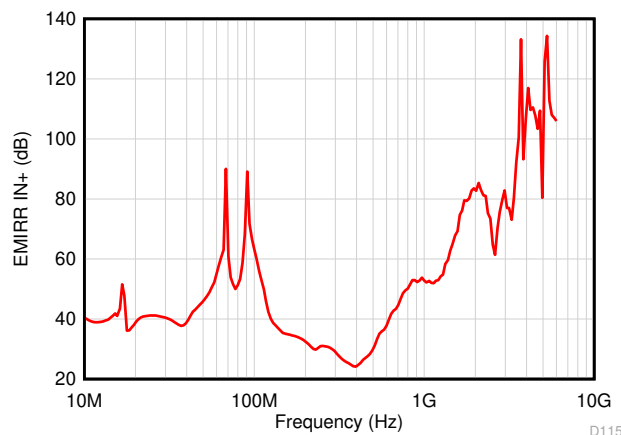

**Figure 7-3. OPA165x EMIRR vs Frequency**

Table 7-1 lists the EMIRR IN+ values for the OPA165x at particular frequencies commonly encountered in real-world applications. Applications listed in Table 7-1 can be centered on or operated near the particular frequency shown. This information can be of special interest to designers working with these types of applications, or working in other fields likely to encounter RF interference from broad sources, such as the industrial, scientific, and medical (ISM) radio band.

**Table 7-1. OPA165x EMIRR IN+ for Frequencies of Interest**

FREQUENCY	APPLICATION OR ALLOCATION	EMIRR IN+
400 MHz	Mobile radio, mobile satellite, space operation, weather, radar, UHF	36 dB
900 MHz	GSM, radio communication and navigation, GPS (to 1.6 GHz), ISM, aeronautical mobile, UHF	42 dB
1.8 GHz	GSM, mobile personal comm. broadband, satellite, L-band	52 dB
2.4 GHz	802.11b/g/n, Bluetooth® mobile personal comm., ISM, amateur radio and satellite, S-band	64 dB
3.6 GHz	Radiolocation, aero comm./nav., satellite, mobile, S-band	67 dB
5 GHz	802.11a/n, aero communication and navigation, mobile communication, space and satellite operation, C-band	77 dB

### 7.3.3.1 EMIRR IN+ Test Configuration

Figure 7-4 shows the circuit configuration for testing the EMIRR IN+. An RF source is connected to the operational amplifier noninverting input pin using a transmission line. The operational amplifier is configured in a unity-gain buffer topology with the output connected to a low-pass filter (LPF) and a digital multimeter (DMM). A large impedance mismatch at the operational amplifier input causes a voltage reflection; however, this effect is characterized and accounted for when determining the EMIRR IN+. The resulting dc offset voltage is sampled and measured by the multimeter. The LPF isolates the multimeter from residual RF signals that can interfere with multimeter accuracy. See the [EMI Rejection Ratio of Operational Amplifiers application report](#) for more details.

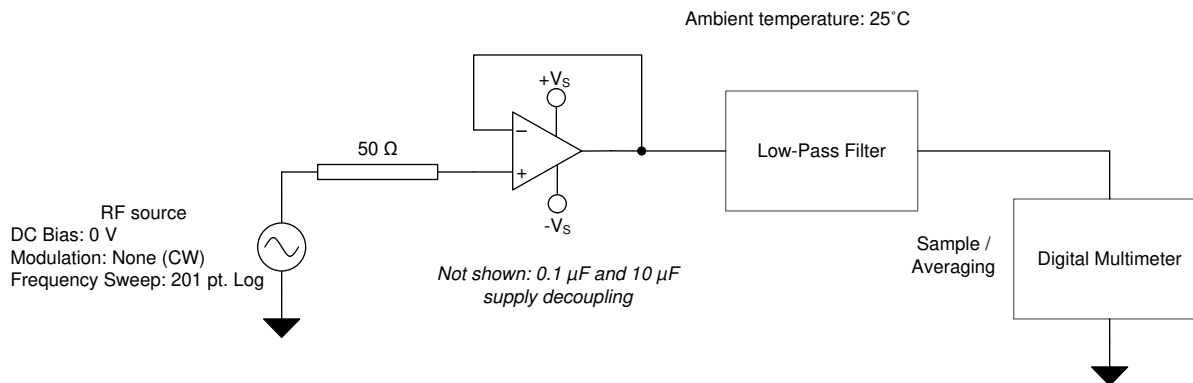

**Figure 7-4. EMIRR IN+ Test Configuration Schematic**

## 7.4 Device Functional Modes

The OPA165x have a single functional mode and are operational when the power-supply voltage is greater than 4.5 V. The maximum specified power-supply voltage for the OPA165x is 36 V.

In all cases, the common-mode voltage must be maintained within the specified range. In addition, key parameters are specified over the temperature range of  $T_A = -40^\circ\text{C}$  to  $+125^\circ\text{C}$ .

## 8 Application and Implementation

### Note

Information in the following applications sections is not part of the TI component specification, and TI does not warrant its accuracy or completeness. TI's customers are responsible for determining suitability of components for their purposes, as well as validating and testing their design implementation to confirm system functionality.

### 8.1 Application Information

#### 8.1.1 Basic Noise Calculations

Low-noise circuit design requires careful analysis of all noise sources. External noise sources can dominate in many cases; consider the effect of source resistance on overall op amp noise performance. Total noise of the circuit is the root-sum-square combination of all noise components.

Figure 8-1 shows noninverting (A) and inverting (B) op amp circuit configurations with gain. In circuit configurations with gain, the feedback network resistors contribute noise. In general, the current noise of the op amp reacts with the feedback resistors to create additional noise components.

The selected feedback resistor values make these noise sources negligible. Low impedance feedback resistors load the output of the amplifier. The equations for total noise are shown for both configurations.

(A) Noise in Noninverting Gain Configuration

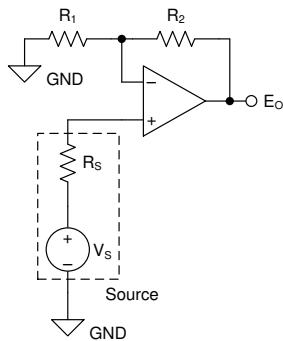

Noise at the output is given as  $E_O$ , where

$$(1) \quad E_O = \left(1 + \frac{R_2}{R_1}\right) \cdot \sqrt{(e_S)^2 + (e_N)^2 + (e_{R_1 \parallel R_2})^2 + (i_N \cdot R_S)^2 + \left(i_N \cdot \frac{R_1 \cdot R_2}{R_1 + R_2}\right)^2} \quad [V_{RMS}]$$

$$(2) \quad e_S = \sqrt{4 \cdot k_B \cdot T(K) \cdot R_S} \quad \left[\frac{V}{\sqrt{Hz}}\right] \quad \text{Thermal noise of } R_S$$

$$(3) \quad e_{R_1 \parallel R_2} = \sqrt{4 \cdot k_B \cdot T(K) \cdot \frac{R_1 \cdot R_2}{R_1 + R_2}} \quad \left[\frac{V}{\sqrt{Hz}}\right] \quad \text{Thermal noise of } R_1 \parallel R_2$$

$$(4) \quad k_B = 1.38065 \cdot 10^{-23} \quad \left[\frac{J}{K}\right] \quad \text{Boltzmann Constant}$$

$$(5) \quad T(K) = 237.15 + T(^{\circ}C) \quad [K] \quad \text{Temperature in kelvins}$$

(B) Noise in Inverting Gain Configuration

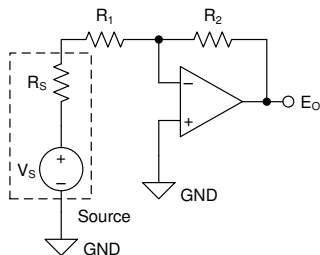

Noise at the output is given as  $E_O$ , where

$$(6) \quad E_O = \left(1 + \frac{R_2}{R_S + R_1}\right) \cdot \sqrt{(e_N)^2 + (e_{R_1 + R_S \parallel R_2})^2 + \left(i_N \cdot \frac{(R_S + R_1) \cdot R_2}{R_S + R_1 + R_2}\right)^2} \quad [V_{RMS}]$$

$$(7) \quad e_{R_1 + R_S \parallel R_2} = \sqrt{4 \cdot k_B \cdot T(K) \cdot \frac{(R_S + R_1) \cdot R_2}{R_S + R_1 + R_2}} \quad \left[\frac{V}{\sqrt{Hz}}\right] \quad \text{Thermal noise of } (R_1 + R_S) \parallel R_2$$

$$(8) \quad k_B = 1.38065 \cdot 10^{-23} \quad \left[\frac{J}{K}\right] \quad \text{Boltzmann Constant}$$

$$(9) \quad T(K) = 237.15 + T(^{\circ}C) \quad [K] \quad \text{Temperature in kelvins}$$

Copyright © 2017, Texas Instruments Incorporated

where

- $e_N$  is the voltage noise of the amplifier. For the OPA165x,  $e_N = 4.3 \text{ nV}/\sqrt{\text{Hz}}$  at 1 kHz.
- $i_N$  is the current noise of the amplifier. For the OPA165x,  $i_N = 6 \text{ fA}/\sqrt{\text{Hz}}$  at 1 kHz.

Note: For additional resources on noise calculations, see [TI's Precision Labs Series](#).

**Figure 8-1. Noise Calculation in Gain Configurations**

## 8.2 Typical Applications

### 8.2.1 Preamplifier Circuit for Vinyl Record Playback With Moving-Magnet Phono Cartridges

The noise and distortion performance of the OPA165x is exceptional in applications with high source impedances, which makes these devices an excellent choice in preamplifier circuits for moving magnet phono cartridges. The high source impedance of the cartridge, and high gain required by the RIAA playback curve at low frequency, requires an amplifier with both low input current noise and low input voltage noise.

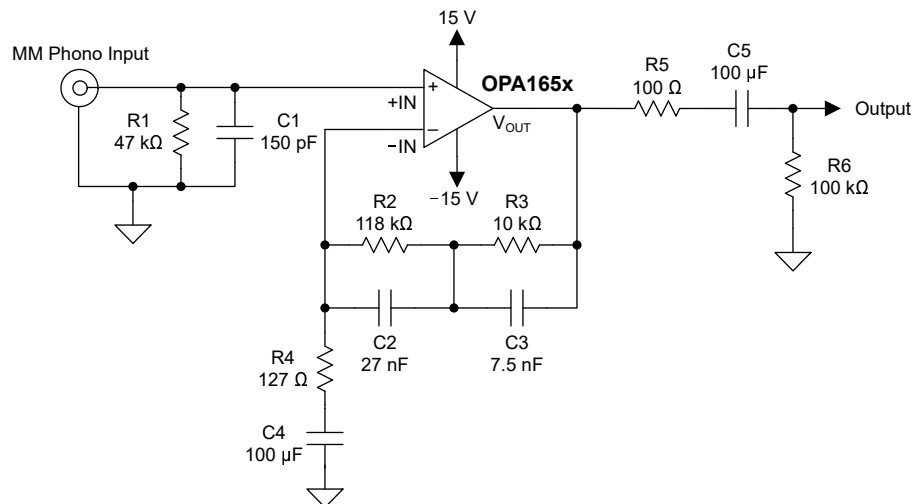

**Figure 8-2. Preamplifier Circuit for Vinyl Record Playback With Moving-Magnet Phono Cartridges (Single Channel Shown)**

#### 8.2.1.1 Design Requirements

- Gain: 40 dB (1 kHz)
- RIAA accuracy:  $\pm 0.5$  dB (100 Hz to 20 kHz)
- Power supplies:  $\pm 15$  V

### 8.2.1.2 Detailed Design Procedure

Vinyl records are recorded using an equalization curve specified by the Recording Institute Association of America (RIAA). The purpose of this equalization curve is to decrease the amount of space occupied by a groove on the record and therefore maximize the amount of information able to be stored. Proper playback of music stored on the record requires a preamplifier circuit that applies the inverse transfer function of the recording equalization curve. The combination of the recording equalization and the playback equalization results in a flat frequency response over the audio range, as Figure 8-3 shows.

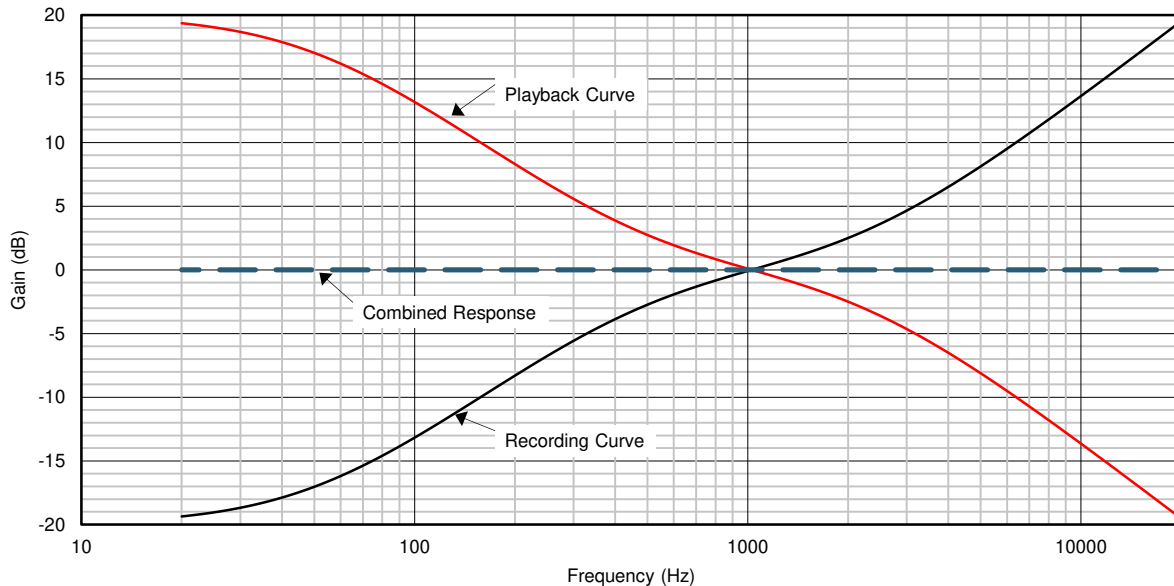

**Figure 8-3. RIAA Recording and Playback Curves Normalized at 1 kHz**

The basic RIAA playback curve implements three time constants: 75  $\mu$ s, 380  $\mu$ s, and 3180  $\mu$ s. An IEC amendment was later added to the playback curve and implements a pole in the curve at 20 Hz with the intent of protecting loudspeakers from excessive low frequency content. Rather than strictly adhering to the IEC amendment, this design moves this pole to a lower frequency to improve low frequency response and still provide protection for loudspeakers.

Resistor R1 and capacitor C1 are selected to provide the proper input impedance for the moving magnet cartridge. Cartridge loading is specified by the manufacturer in the cartridge datasheet and is absolutely crucial for proper response at high frequency. 47 k $\Omega$  is a common value for the input resistor, and the capacitive loading is usually specified from 200 pF to 300 pF per channel. This capacitive loading specification includes the capacitance of the cable connecting the turntable to the preamplifier, as well as any additional parasitic capacitances at the preamplifier input. Therefore, the value of C1 must be less than the loading specification to account for these additional capacitances.

The output network consisting of R5, R6, and C5 serves to ac couple the preamplifier circuit to any subsequent electronics in the signal path. 100- $\Omega$  resistor R5 limits in-rush current into coupling capacitor C5 and prevents parasitic capacitance from cabling from causing instability. R6 prevents charge accumulation on C5. Capacitor C5 is chosen to be the same value as C4; for simplicity however, the value of C5 must be large enough to avoid attenuating low-frequency information.

The feedback resistor elements must be selected to provide the correct response within the audio bandwidth. In order to achieve the correct frequency response, the passive components in [Figure 8-2](#) must satisfy [Equation 1](#), [Equation 2](#), and [Equation 3](#):

$$R_2 \times C_2 = 3180 \mu\text{s} \quad (1)$$

$$R_3 \times C_3 = 75 \mu\text{s} \quad (2)$$

$$(R_2 \parallel R_3) \times (C_2 + C_3) = 318 \mu\text{s} \quad (3)$$

R2, R3, and R4 must also be selected to meet the design requirements for gain. The gain at 1 kHz is determined by subtracting 20 dB from gain of the circuit at very low-frequency (near dc), as shown in [Equation 4](#):

$$A_{1\text{kHz}} = A_{\text{LF}} - 20 \text{ dB} \quad (4)$$

Therefore, the low frequency gain of the circuit must be 60 dB to meet the goal of 40 dB at 1 kHz and is determined by resistors R2, R3, and R4 as shown in [Equation 5](#):

$$A_{\text{LF}} = 1 + \frac{R_3 + R_2}{R_4} = 1000 \text{ (60 dB)} \quad (5)$$

Because there are multiple combinations of passive components that satisfy these equations, a spreadsheet or other software calculation tool is the easiest method to examine resistor and capacitor combinations.

Capacitor C4 forces the gain of the circuit to unity at dc in order to limit the offset voltage at the output of the preamplifier circuit. The high-pass corner frequency created by this capacitor is calculated by [Equation 6](#):

$$F_{\text{HP}} = \frac{1}{2\pi R_4 C_4} \quad (6)$$

The circuit described in [Figure 8-2](#) is constructed with 1% tolerance resistors and 5% tolerance NP0, C0G ceramic capacitors without any additional hand sorting. The large value of C4 typically requires an electrolytic type to be used. However, electrolytic capacitors have the potential to introduce distortion into the signal path. This circuit is constructed using a bipolar electrolytic capacitor specifically intended for audio applications.

### 8.2.1.3 Application Curves

The deviation from the ideal RIAA transfer function curve is shown in [Figure 8-4](#) and normalized to an ideal gain of 40 dB at 1 kHz. The measured gain at 1 kHz is 0.05 dB less than the design goal, and the maximum deviation from 100 Hz to 20 kHz is 0.18 dB. The deviation from the ideal curve can be improved by hand-sorting resistor and capacitor values to their ideal values. The value of C4 can also be increased to reduce the deviation at low frequency.

A spectrum of the preamplifier output signal is shown in [Figure 8-5](#) for a 10 mV<sub>RMS</sub>, 1-kHz input signal (1-V<sub>RMS</sub> output). All distortion harmonics are below the preamplifier noise floor.

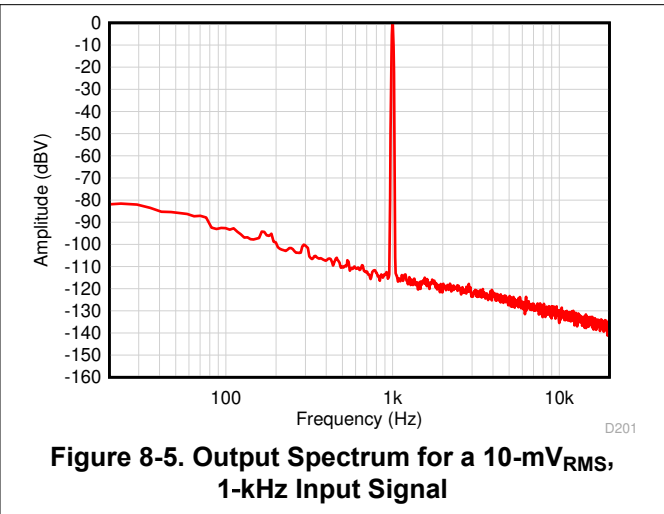
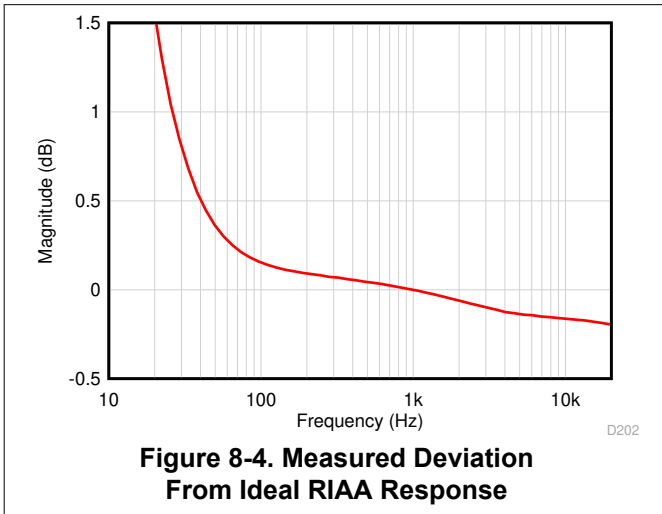

### 8.2.2 Composite Headphone Amplifier

Figure 8-6 shows the BUF634A buffer inside the feedback loop of the OPA165x to increase the available output current for low-impedance headphones. If the BUF634A is used in wide-bandwidth mode, no additional components beyond the feedback resistors are required to maintain loop stability.

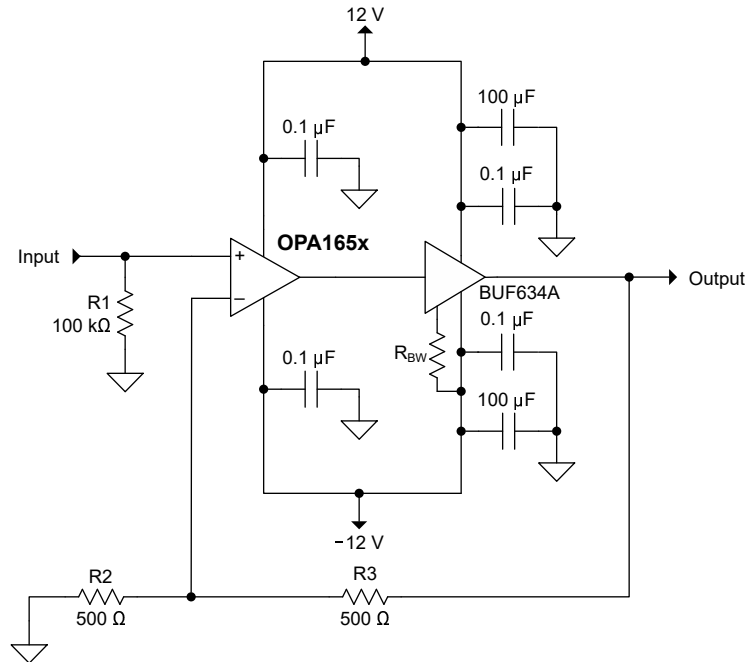

Figure 8-6. Composite Headphone Amplifier (Single-Channel Shown)

#### 8.2.2.1 Application Curves

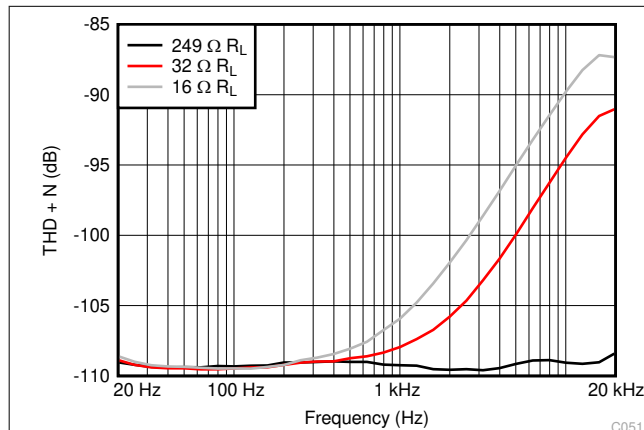

Figure 8-7. THD+N vs Frequency for a 5-V<sub>PP</sub> (1.77-V<sub>RMS</sub>) Input Signal

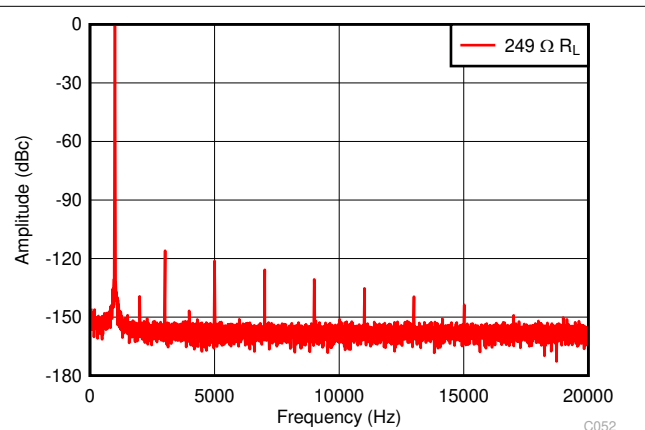

Figure 8-8. FFT for a 5-V<sub>PP</sub> (1.77-V<sub>RMS</sub>), 1-kHz Input Signal

### 8.2.3 Baxandall Tone Control

Figure 8-9 gives an example of ultra-low noise and THD tone control. This circuit provides 20 dB of gain at the first stage, followed by two separate tone controls for bass and treble. The passive circuit is designed to yield a flat gain response with the potentiometers both set to 50%.

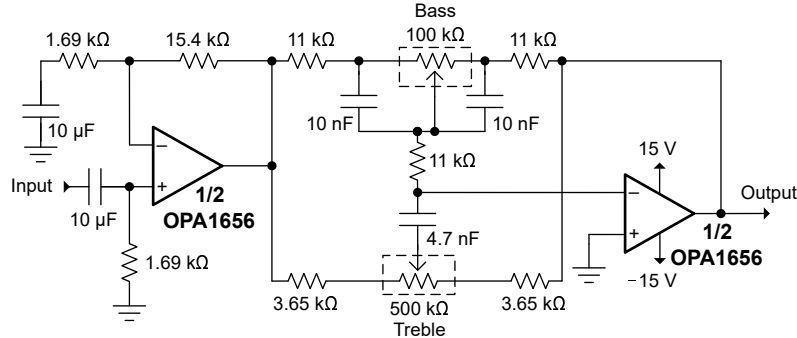

Figure 8-9. Dual Potentiometer Baxandall Tone Control

#### 8.2.3.1 Application Curves

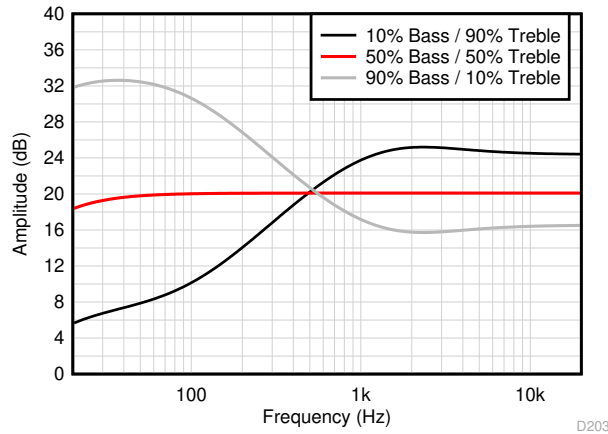

Figure 8-10. Amplitude vs Frequency for Various Tone-Control Settings

### 8.2.4 Guitar Input to XLR Output

The OPA165x are an excellent choice for guitar input circuits as a result of the high input impedance and ultra-low noise performance. Figure 8-11 gives an example of a basic guitar input circuit to differential XLR schematic. The logarithmic taper potentiometer shown in this circuit provides 6 dB of gain at 0%, and 40 dB of gain at 100%. The rail-to-rail output swing of the OPA165x allows for a high amplitude swing at the outputs of the differentially configured amplifiers, while maintaining very low distortion performance. A 10- $\mu$ F dc blocking capacitor is used in the feedback of the noninverting stage to remove any dc offset as a result of the amplifier offset voltage. However, this dc blocking capacitor can be eliminated for applications that are not sensitive to low dc offsets.

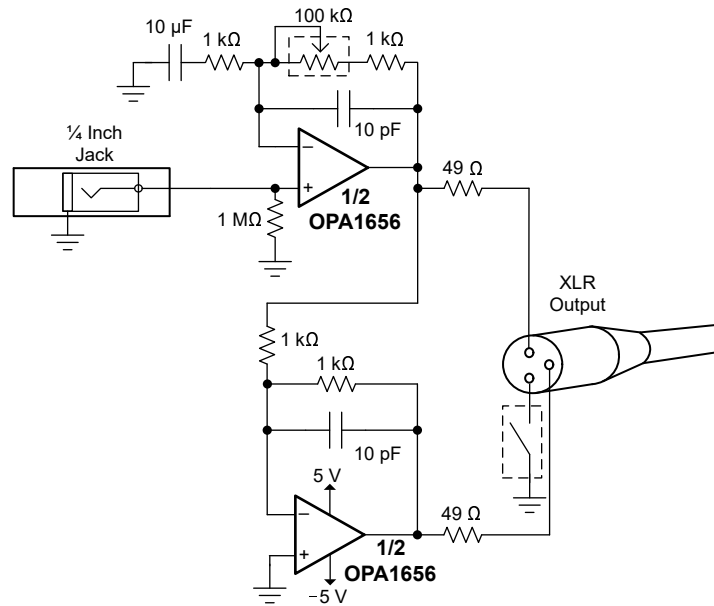

Figure 8-11. Guitar Input to XLR Output Schematic

#### 8.2.4.1 Application Curves

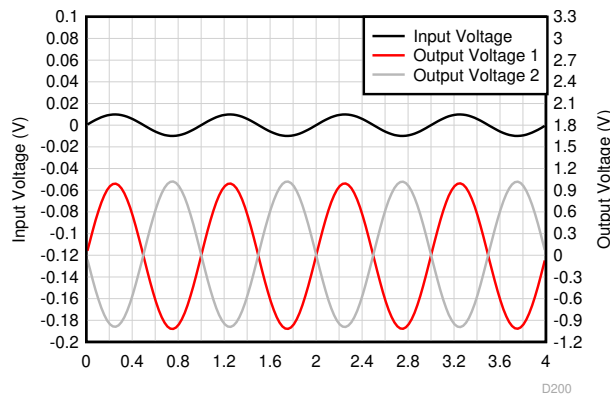

Figure 8-12. 1-kHz Input Signal Transient Simulation

## 8.3 Power Supply Recommendations

The OPA165x are specified for operation from 4.5 V to 36 V ( $\pm 2.25$  V to  $\pm 18$  V); many specifications apply from  $-40^{\circ}\text{C}$  to  $+125^{\circ}\text{C}$ . Parameters that can exhibit significant variance with regard to operating voltage or temperature are presented in the [Typical Characteristics](#) section.

The OPA165x operate with as little as 4.5 V between the supplies and with up to 36 V between the supplies. However, some applications do not require equal positive and negative output voltage swing. With the OPA165x, power-supply voltages are not required to be equal. For example, the positive supply can be set to 25 V with the negative supply at  $-5$  V.

## 8.4 Layout

### 8.4.1 Layout Guidelines

For best operational performance of the device, use good printed-circuit board (PCB) layout practices, including:

- Noise can propagate into analog circuitry through the power pins of the circuit as a whole and of op amp itself. Bypass capacitors are used to reduce the coupled noise by providing low-impedance power sources local to the analog circuitry.
  - Connect low-ESR, 0.1- $\mu\text{F}$  ceramic bypass capacitors between each supply pin and ground, placed as close to the device as possible. A single bypass capacitor from V+ to ground is applicable for single-supply applications.
- Separate grounding for analog and digital portions of circuitry is one of the simplest and most-effective methods of noise suppression. One or more layers on multilayer PCBs are usually devoted to ground planes. A ground plane helps distribute heat and reduces electromagnetic interference (EMI) noise pickup. Physically separate digital and analog grounds, observing the flow of the ground current.
- To reduce parasitic coupling, run the input traces as far away from the supply or output traces as possible. If these traces cannot be kept separate, crossing the sensitive trace perpendicular is much better as opposed to in parallel with the noisy trace.
- Place the external components as close to the device as possible. As illustrated in [Figure 8-13](#), keeping  $R_F$  and  $R_G$  close to the inverting input minimizes parasitic capacitance.
- Keep the length of input traces as short as possible. Always remember that the input traces are the most sensitive part of the circuit.
- Consider a driven, low-impedance guard ring around the critical traces. A guard ring can significantly reduce leakage currents from nearby traces that are at different potentials.
- Cleaning the PCB following board assembly is recommended for best performance.
- Any precision integrated circuit can experience performance shifts resulting from moisture ingress into the plastic package. Following any aqueous PCB cleaning process, baking the PCB assembly is recommended to remove moisture introduced into the device packaging during the cleaning process. A low-temperature, post-cleaning bake at  $85^{\circ}\text{C}$  for 30 minutes is sufficient for most circumstances.

#### 8.4.1.1 Power Dissipation

The OPA165x op amps are capable of driving 600- $\Omega$  loads with a power-supply voltage up to  $\pm 18$  V and full operating temperature range. Internal power dissipation increases when operating at high supply voltages. Copper leadframe construction used in the OPA165x improves heat dissipation compared to conventional materials. Circuit board layout can also help minimize junction temperature rise. Wide copper traces help dissipate the heat by acting as an additional heat sink. Temperature rise can be further minimized by soldering the devices to the circuit board rather than using a socket.

### 8.4.2 Layout Example

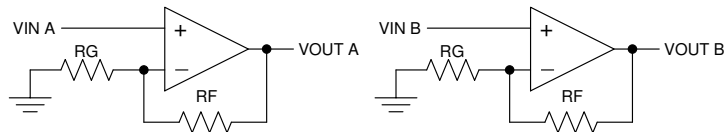

(Schematic Representation)

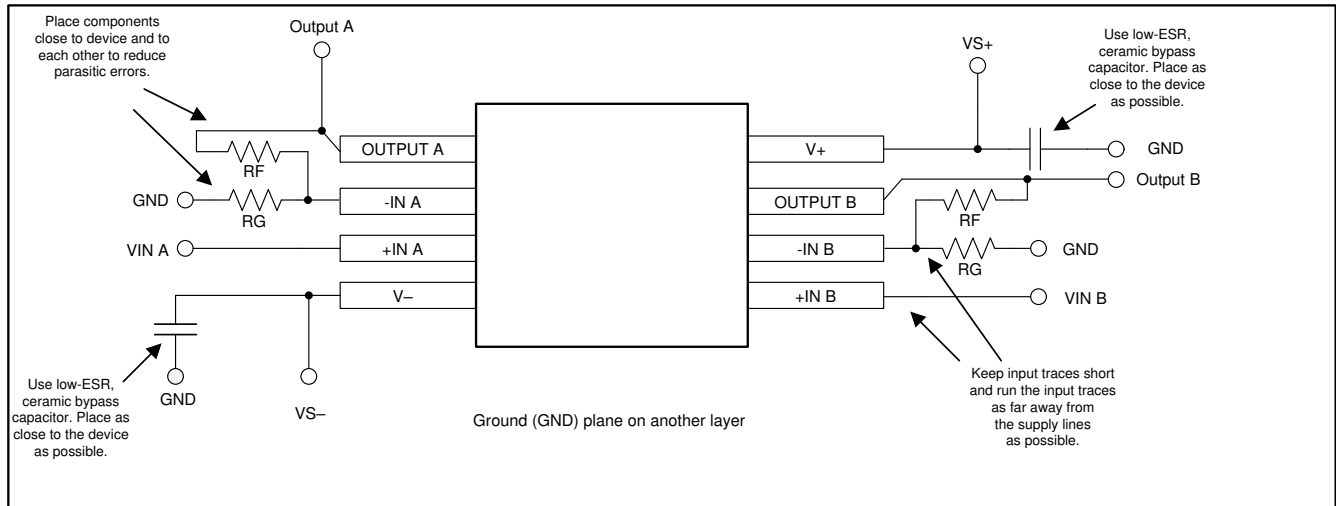

**Figure 8-13. Operational Amplifier Board Layout for Noninverting Configuration**

## 9 Device and Documentation Support

### 9.1 Device Support

#### 9.1.1 Development Support

##### 9.1.1.1 PSpice® for TI

PSpice® for TI is a design and simulation environment that helps evaluate performance of analog circuits. Create subsystem designs and prototype solutions before committing to layout and fabrication, reducing development cost and time to market.

##### 9.1.1.2 TINA-TI™ Simulation Software (Free Download)

TINA-TI™ simulation software is a simple, powerful, and easy-to-use circuit simulation program based on a SPICE engine. TINA-TI simulation software is a free, fully-functional version of the TINA™ software, preloaded with a library of macromodels, in addition to a range of both passive and active models. TINA-TI simulation software provides all the conventional dc, transient, and frequency domain analysis of SPICE, as well as additional design capabilities.

Available as a [free download](#) from the [Design tools and simulation](#) web page, TINA-TI simulation software offers extensive post-processing capability that allows users to format results in a variety of ways. Virtual instruments offer the ability to select input waveforms and probe circuit nodes, voltages, and waveforms, creating a dynamic quick-start tool.

---

#### Note

These files require that either the TINA software or TINA-TI software be installed. Download the free TINA-TI simulation software from the [TINA-TI™ software folder](#).

---

##### 9.1.1.3 DIP-Adapter-EVM

Speed up your op amp prototyping and testing with the [DIP-Adapter-EVM](#), which provides a fast, easy and inexpensive way to interface with small, surface-mount devices. Connect any supported op amp using the included Samtec terminal strips or wire them directly to existing circuits. The DIP-Adapter-EVM kit supports the following industry-standard packages: D or U (SOIC-8), PW (TSSOP-8), DGK (VSSOP-8), DBV (SOT-23-6, SOT-23-5 and SOT-23-3), DCK (SC70-6 and SC70-5), and DRL (SOT563-6).

##### 9.1.1.4 DIYAMP-EVM

The [DIYAMP-EVM](#) is a unique evaluation module (EVM) that provides real-world amplifier circuits, enabling the user to quickly evaluate design concepts and verify simulations. This EVM is available in three industry-standard packages (SC70, SOT23, and SOIC) and 12 popular amplifier configurations, including amplifiers, filters, stability compensation, and comparator configurations for both single and dual supplies.

##### 9.1.1.5 TI Reference Designs

TI reference designs are analog solutions created by TI's precision analog applications experts. TI reference designs offer the theory of operation, component selection, simulation, complete PCB schematic and layout, bill of materials, and measured performance of many useful circuits. TI reference designs are available online at <https://www.ti.com/reference-designs>.

##### 9.1.1.6 Filter Design Tool

The [filter design tool](#) is a simple, powerful, and easy-to-use active filter design program. The filter design tool allows the user to create optimized filter designs using a selection of TI operational amplifiers and passive components from TI's vendor partners.

Available as a web-based tool from the [Design tools and simulation](#) web page, the [filter design tool](#) allows the user to design, optimize, and simulate complete multistage active filter solutions within minutes.

## 9.2 Documentation Support

### 9.2.1 Related Documentation

The following documents are recommended for reference when using the OPA165x, and are available for download at [www.ti.com](http://www.ti.com).

- Texas Instruments, [Source Resistance and Noise Considerations in Amplifiers](#) technical brief
- Texas Instruments, [Single-Supply Operation of Operational Amplifiers](#) application bulletin
- Texas Instruments, [Op Amp Performance Analysis](#) application bulletin
- Texas Instruments, [Compensate Transimpedance Amplifiers Intuitively](#) application report
- Texas Instruments, [Tuning in Amplifiers](#) application bulletin
- Texas Instruments, [Feedback Plots Define Op Amp AC Performance](#) application bulletin
- Texas Instruments, [Active Volume Control for Professional Audio](#) design guide

### 9.3 Receiving Notification of Documentation Updates

To receive notification of documentation updates, navigate to the device product folder on [ti.com](http://ti.com). Click on *Subscribe to updates* to register and receive a weekly digest of any product information that has changed. For change details, review the revision history included in any revised document.

### 9.4 Support Resources

[TI E2E™ support forums](#) are an engineer's go-to source for fast, verified answers and design help — straight from the experts. Search existing answers or ask your own question to get the quick design help you need.

Linked content is provided "AS IS" by the respective contributors. They do not constitute TI specifications and do not necessarily reflect TI's views; see TI's [Terms of Use](#).

### 9.5 Trademarks

Burr-Brown™, TINA-TI™, and TI E2E™ are trademarks of Texas Instruments.

TINA™ is a trademark of DesignSoft, Inc.

Bluetooth® is a registered trademark of Bluetooth SIG, Inc.

PSpice® is a registered trademark of Cadence Design Systems, Inc.

All trademarks are the property of their respective owners.

### 9.6 Electrostatic Discharge Caution



This integrated circuit can be damaged by ESD. Texas Instruments recommends that all integrated circuits be handled with appropriate precautions. Failure to observe proper handling and installation procedures can cause damage.

ESD damage can range from subtle performance degradation to complete device failure. Precision integrated circuits may be more susceptible to damage because very small parametric changes could cause the device not to meet its published specifications.

### 9.7 Glossary

[TI Glossary](#) This glossary lists and explains terms, acronyms, and definitions.

## 10 Mechanical, Packaging, and Orderable Information

The following pages include mechanical, packaging, and orderable information. This information is the most current data available for the designated devices. This data is subject to change without notice and revision of this document. For browser-based versions of this data sheet, refer to the left-hand navigation.

**PACKAGING INFORMATION**

Orderable Device	Status (1)	Package Type	Package Drawing	Pins	Package Qty	Eco Plan (2)	Lead finish/ Ball material (6)	MSL Peak Temp (3)	Op Temp (°C)	Device Marking (4/5)	Samples
OPA1655DBVR	ACTIVE	SOT-23	DBV	5	3000	RoHS & Green	SN	Level-2-260C-1 YEAR	-40 to 125	2R8Q	<a href="#">Samples</a>
OPA1655DBVT	ACTIVE	SOT-23	DBV	5	250	RoHS & Green	SN	Level-2-260C-1 YEAR	-40 to 125	2R8Q	<a href="#">Samples</a>
OPA1655DR	ACTIVE	SOIC	D	8	3000	RoHS & Green	NIPDAU	Level-2-260C-1 YEAR	-40 to 125	OP1655	<a href="#">Samples</a>
OPA1656ID	ACTIVE	SOIC	D	8	75	RoHS & Green	NIPDAU	Level-2-260C-1 YEAR	-40 to 125	OP1656	<a href="#">Samples</a>
OPA1656IDR	ACTIVE	SOIC	D	8	2500	RoHS & Green	NIPDAU	Level-2-260C-1 YEAR	-40 to 125	OP1656	<a href="#">Samples</a>

(1) The marketing status values are defined as follows:

**ACTIVE:** Product device recommended for new designs.

**LIFEBUY:** TI has announced that the device will be discontinued, and a lifetime-buy period is in effect.

**NRND:** Not recommended for new designs. Device is in production to support existing customers, but TI does not recommend using this part in a new design.

**PREVIEW:** Device has been announced but is not in production. Samples may or may not be available.

**OBSELETE:** TI has discontinued the production of the device.

(2) **RoHS:** TI defines "RoHS" to mean semiconductor products that are compliant with the current EU RoHS requirements for all 10 RoHS substances, including the requirement that RoHS substance do not exceed 0.1% by weight in homogeneous materials. Where designed to be soldered at high temperatures, "RoHS" products are suitable for use in specified lead-free processes. TI may reference these types of products as "Pb-Free".

**RoHS Exempt:** TI defines "RoHS Exempt" to mean products that contain lead but are compliant with EU RoHS pursuant to a specific EU RoHS exemption.

**Green:** TI defines "Green" to mean the content of Chlorine (Cl) and Bromine (Br) based flame retardants meet JS709B low halogen requirements of <=1000ppm threshold. Antimony trioxide based flame retardants must also meet the <=1000ppm threshold requirement.

(3) MSL, Peak Temp. - The Moisture Sensitivity Level rating according to the JEDEC industry standard classifications, and peak solder temperature.

(4) There may be additional marking, which relates to the logo, the lot trace code information, or the environmental category on the device.

(5) Multiple Device Markings will be inside parentheses. Only one Device Marking contained in parentheses and separated by a "~" will appear on a device. If a line is indented then it is a continuation of the previous line and the two combined represent the entire Device Marking for that device.

(6) Lead finish/Ball material - Orderable Devices may have multiple material finish options. Finish options are separated by a vertical ruled line. Lead finish/Ball material values may wrap to two lines if the finish value exceeds the maximum column width.

**Important Information and Disclaimer:** The information provided on this page represents TI's knowledge and belief as of the date that it is provided. TI bases its knowledge and belief on information provided by third parties, and makes no representation or warranty as to the accuracy of such information. Efforts are underway to better integrate information from third parties. TI has taken and continues to take reasonable steps to provide representative and accurate information but may not have conducted destructive testing or chemical analysis on incoming materials and chemicals. TI and TI suppliers consider certain information to be proprietary, and thus CAS numbers and other limited information may not be available for release.

In no event shall TI's liability arising out of such information exceed the total purchase price of the TI part(s) at issue in this document sold by TI to Customer on an annual basis.

**TAPE AND REEL INFORMATION**

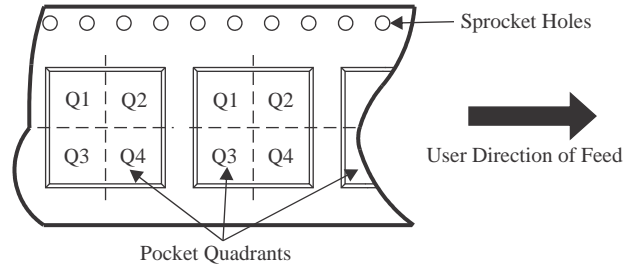
**QUADRANT ASSIGNMENTS FOR PIN 1 ORIENTATION IN TAPE**

\*All dimensions are nominal

Device	Package Type	Package Drawing	Pins	SPQ	Reel Diameter (mm)	Reel Width W1 (mm)	A0 (mm)	B0 (mm)	K0 (mm)	P1 (mm)	W (mm)	Pin1 Quadrant
OPA1655DBVR	SOT-23	DBV	5	3000	178.0	9.0	3.3	3.2	1.4	4.0	8.0	Q3
OPA1655DBVT	SOT-23	DBV	5	250	178.0	9.0	3.3	3.2	1.4	4.0	8.0	Q3
OPA1655DR	SOIC	D	8	3000	330.0	12.4	6.4	5.2	2.1	8.0	12.0	Q1
OPA1656IDR	SOIC	D	8	2500	330.0	12.4	6.4	5.2	2.1	8.0	12.0	Q1

**TAPE AND REEL BOX DIMENSIONS**

\*All dimensions are nominal

Device	Package Type	Package Drawing	Pins	SPQ	Length (mm)	Width (mm)	Height (mm)
OPA1655DBVR	SOT-23	DBV	5	3000	190.0	190.0	30.0
OPA1655DBVT	SOT-23	DBV	5	250	190.0	190.0	30.0
OPA1655DR	SOIC	D	8	3000	356.0	356.0	35.0
OPA1656IDR	SOIC	D	8	2500	356.0	356.0	35.0

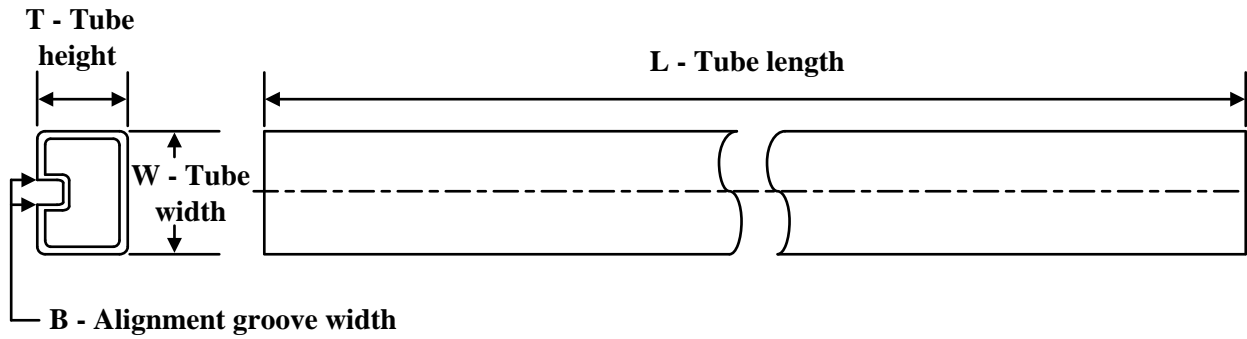
**TUBE**

\*All dimensions are nominal

Device	Package Name	Package Type	Pins	SPQ	L (mm)	W (mm)	T (μm)	B (mm)
OPA1656ID	D	SOIC	8	75	506.6	8	3940	4.32



# EXAMPLE BOARD LAYOUT

DBV0005A

SOT-23 - 1.45 mm max height

SMALL OUTLINE TRANSISTOR

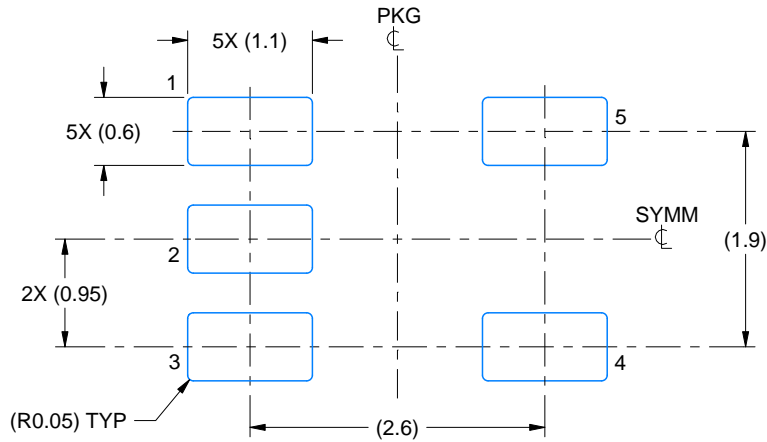

LAND PATTERN EXAMPLE  
EXPOSED METAL SHOWN  
SCALE:15X

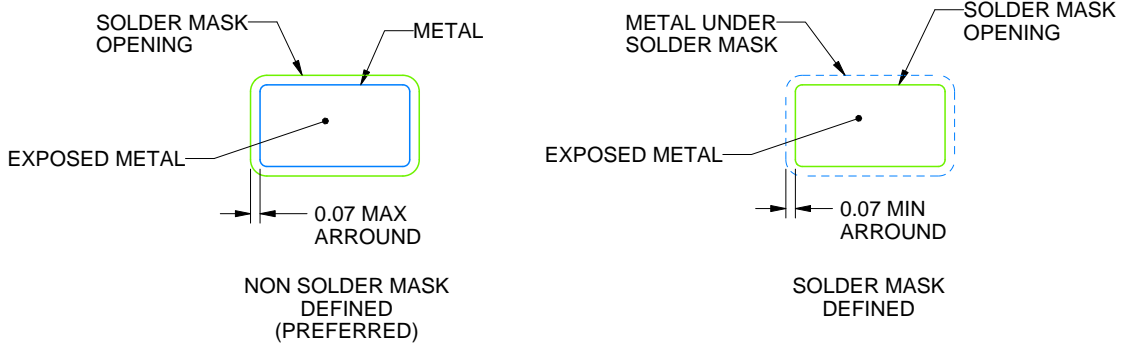

SOLDER MASK DETAILS

4214839/J 02/2024

NOTES: (continued)

- 6. Publication IPC-7351 may have alternate designs.
- 7. Solder mask tolerances between and around signal pads can vary based on board fabrication site.

# EXAMPLE STENCIL DESIGN

DBV0005A

SOT-23 - 1.45 mm max height

SMALL OUTLINE TRANSISTOR

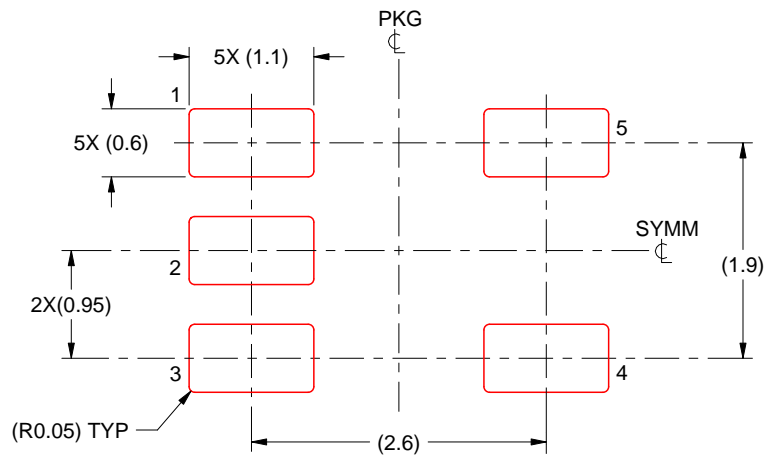

SOLDER PASTE EXAMPLE  
BASED ON 0.125 mm THICK STENCIL  
SCALE:15X

4214839/J 02/2024

NOTES: (continued)

8. Laser cutting apertures with trapezoidal walls and rounded corners may offer better paste release. IPC-7525 may have alternate design recommendations.
9. Board assembly site may have different recommendations for stencil design.



D0008A

# PACKAGE OUTLINE

SOIC - 1.75 mm max height

SMALL OUTLINE INTEGRATED CIRCUIT



4214825/C 02/2019

NOTES:

1. Linear dimensions are in inches [millimeters]. Dimensions in parenthesis are for reference only. Controlling dimensions are in inches. Dimensioning and tolerancing per ASME Y14.5M.
2. This drawing is subject to change without notice.
3. This dimension does not include mold flash, protrusions, or gate burrs. Mold flash, protrusions, or gate burrs shall not exceed  $.006$  [0.15] per side.
4. This dimension does not include interlead flash.
5. Reference JEDEC registration MS-012, variation AA.

# EXAMPLE BOARD LAYOUT

D0008A

SOIC - 1.75 mm max height

SMALL OUTLINE INTEGRATED CIRCUIT



LAND PATTERN EXAMPLE  
 EXPOSED METAL SHOWN  
 SCALE:8X



SOLDER MASK DETAILS

4214825/C 02/2019

NOTES: (continued)

- 6. Publication IPC-7351 may have alternate designs.
- 7. Solder mask tolerances between and around signal pads can vary based on board fabrication site.

# EXAMPLE STENCIL DESIGN

D0008A

SOIC - 1.75 mm max height

SMALL OUTLINE INTEGRATED CIRCUIT



SOLDER PASTE EXAMPLE  
BASED ON .005 INCH [0.125 MM] THICK STENCIL  
SCALE:8X

4214825/C 02/2019

NOTES: (continued)

8. Laser cutting apertures with trapezoidal walls and rounded corners may offer better paste release. IPC-7525 may have alternate design recommendations.
9. Board assembly site may have different recommendations for stencil design.

## IMPORTANT NOTICE AND DISCLAIMER

TI PROVIDES TECHNICAL AND RELIABILITY DATA (INCLUDING DATA SHEETS), DESIGN RESOURCES (INCLUDING REFERENCE DESIGNS), APPLICATION OR OTHER DESIGN ADVICE, WEB TOOLS, SAFETY INFORMATION, AND OTHER RESOURCES "AS IS" AND WITH ALL FAULTS, AND DISCLAIMS ALL WARRANTIES, EXPRESS AND IMPLIED, INCLUDING WITHOUT LIMITATION ANY IMPLIED WARRANTIES OF MERCHANTABILITY, FITNESS FOR A PARTICULAR PURPOSE OR NON-INFRINGEMENT OF THIRD PARTY INTELLECTUAL PROPERTY RIGHTS.

These resources are intended for skilled developers designing with TI products. You are solely responsible for (1) selecting the appropriate TI products for your application, (2) designing, validating and testing your application, and (3) ensuring your application meets applicable standards, and any other safety, security, regulatory or other requirements.

These resources are subject to change without notice. TI grants you permission to use these resources only for development of an application that uses the TI products described in the resource. Other reproduction and display of these resources is prohibited. No license is granted to any other TI intellectual property right or to any third party intellectual property right. TI disclaims responsibility for, and you will fully indemnify TI and its representatives against, any claims, damages, costs, losses, and liabilities arising out of your use of these resources.

TI's products are provided subject to [TI's Terms of Sale](#) or other applicable terms available either on [ti.com](https://www.ti.com) or provided in conjunction with such TI products. TI's provision of these resources does not expand or otherwise alter TI's applicable warranties or warranty disclaimers for TI products.

TI objects to and rejects any additional or different terms you may have proposed.

Mailing Address: Texas Instruments, Post Office Box 655303, Dallas, Texas 75265  
Copyright © 2024, Texas Instruments Incorporated

## Looking for pricing, stock, or lifecycle information?

Click below to explore more details on WIN SOURCE:

 [View OPA1655DR](#) on WIN SOURCE

 [Texas Instruments](#) Information

## Optimize Your Supply Chain with WIN SOURCE Solutions

-  Global Sourcing Solution
-  Obsolete Management
-  Cost Control Management
-  Shortage Management
-  Alternative Solution
-  Excess Inventory Management