



**THE DATASHEET OF
CY7C65211A-24LTXI**



USB-Serial single-channel (UART/I²C/SPI) bridge with CAPSENSE™ and BCD

Features

- USB 2.0-certified, Full-speed (12 Mbps)
 - Supports communication driver class (CDC), personal health care device class (PHDC), and vendor-device class
 - Battery charger detection (BCD) compliant with USB battery charging specification, Rev. 1.2 (Peripheral detect only)
 - Integrated USB termination resistors
- Single-channel configurable UART interface
 - Data rates up to 3 Mbps
 - 190 bytes for each transmit and receive buffer
 - Supports 2-pin, 4-pin and 6-pin UART interface
 - Data format:
 - 7 to 8 data bits
 - 1 to 2 stop bits
 - No parity, even, odd, mark, or space parity
 - Supports parity, overrun, and framing errors
 - Supports flow control using CTS, RTS, DTR, DSR
 - Supports UART break signal
 - CY7C65211 supports single channel RS232/RS422 interfaces whereas CY7C65211A supports RS232/RS422/RS485 interfaces
- Single-channel configurable SPI interface
 - Data rate up to 3 MHz for SPI master and 1 MHz for SPI slave
 - Data width: 4 bits to 16 bits
 - 256 bytes for each transmit and receive buffer
 - Supports Motorola, TI, and National SPI modes
- Single-channel configurable I²C interface
 - Master/slave up to 400 kHz
 - 256 bytes each transmit and receive buffer
 - Supports multi-master I²C
- CAPSENSE™
 - Smart sensing algorithm for Auto-Tuning is supported through a Infineon-supplied configuration utility
 - Max CAPSENSE™ buttons: 5
 - GPIOs linked to CAPSENSE™ buttons
- General-purpose input/output (GPIO) pins: 10
- Supports unique serial number feature for each device, which fixes the COM port number permanently when USB-serial bridge controller as CDC device plugs in
- 512-byte flash for storing configuration parameters

Applications

- Configuration utility (Windows) to configure the following:
 - Vendor ID (VID), Product ID (PID), and Product and Manufacturer descriptors
 - UART/I²C/SPI
 - CAPSENSE™
 - Charger detection
 - GPIO
- Driver support for VCOM and DLL
 - Windows 10: 32- and 64-bit versions
 - Windows 8.1: 32- and 64-bit versions
 - Windows 8: 32- and 64-bit versions
 - Windows 7: 32- and 64-bit versions
 - Windows Vista: 32- and 64-bit versions
 - Windows XP: 32- and 64-bit versions
 - Windows CE
 - Mac OS-X: 10.6, 10.7
 - Linux: Kernel version 2.6.35 onwards
 - Android: Gingerbread and later versions
- Clocking: Integrated 48-MHz clock oscillator
- Supports bus-/self-powered configurations
- USB Suspend mode for low power
- Operating voltage: 1.71 V to 5.5 V
- Operating temperature:
 - Commercial: 0°C to 70°C
 - Industrial: -40°C to 85°C
 - Automotive: -40°C to 105°C
- ESD protection: 2.2 kV HBM
- RoHS-compliant package
 - 24-pin QFN (4.0 mm × 4.0 mm, 0.55 mm, 0.5 mm pitch)
- Ordering part number
 - CY7C65211-24LTXI
 - CY7C65211A-24LTXI
 - CY7C65211A-24LQXS
 - CY7C65211A-24LQXST

Applications

- Medical/healthcare devices
- Point-of-sale (POS) terminals
- Test and measurement system
- Gaming systems
- Set-top box PC-USB interface
- Industrial
- Automotive
- Networking
- Enabling USB connectivity in legacy peripherals

Table of contents

Features	1
Applications	2
Functional description	3
CY7C65211 and CY7C65211A features comparison	3
1 More information	4
Table of contents	5
2 Block diagram	7
3 Functional overview	8
3.1 USB and charger detect.....	8
3.1.1 USB	8
3.1.2 Charger detection	8
3.2 Serial communication	8
3.2.1 UART interface	8
3.2.2 UART flow control	9
3.2.3 SPI interface	9
3.2.4 I2C interface	9
3.3 CAPSENSE™	10
3.4 GPIO interface	10
3.5 Memory.....	10
3.6 System resources.....	11
3.6.1 Power system.....	11
3.6.2 Clock system	11
3.6.3 Internal 48-MHz oscillator	11
3.6.4 Internal 32-kHz oscillator	11
3.6.5 Reset.....	11
3.7 Suspend and resume	11
3.8 Wakeup.....	11
3.9 Software	12
3.9.1 Drivers for Linux operating systems.....	12
3.9.2 Android support.....	12
3.9.3 Drivers for Mac OSx.....	12
3.9.4 Drivers for Windows operating systems	12
3.9.5 Windows-CE support	12
3.10 Internal flash configuration.....	13
4 Electrical specifications	14
4.1 Absolute maximum ratings	14
4.2 Operating conditions.....	14
4.3 Device-level specifications	15
4.3.1 GPIO.....	16
4.3.2 nXRES.....	18
4.4 Digital peripherals.....	19
4.4.1 UART	19
4.4.2 SPI.....	19
4.4.3 I2C	21
4.5 CAPSENSE™	22
4.6 System resources.....	22
4.6.1 Memory.....	22
5 Pin description	23
6 USB power configurations	25
6.1 USB bus-powered configuration.....	25
6.2 Self-powered configuration	26

6.3 USB bus-powered with variable I/O voltage	27
7 Application examples	28
7.1 USB to RS232 bridge	28
7.2 USB to RS485 Bridge	29
7.3 Battery-operated, bus-powered USB to MCU with battery charge detection	30
7.4 CAPSENSE™	32
7.5 USB to I ² C bridge.....	33
7.6 USB to SPI Bridge	34
8 Ordering information	39
8.1 Ordering code definitions.....	39
9 Package information	40
10 Acronyms	41
11 Document conventions	42
11.1 Units of measure	42
12 Errata	43
Revision history	46

1 Functional description

For a complete list of related resources, click [here](#).

USB-compliant

The USB-Serial Single-Channel Bridge with CAPSENSE™ and BCD (CY7C65211/CY7C65211A) is fully compliant with the USB 2.0 specification and Battery Charging Specification v1.2, USB-IF Test-ID (TID) 40001521.

1.1 CY7C65211 and CY7C65211A features comparison

Table 1 CY7C65211 and CY7C65211A features comparison

Features	CY7C65211	CY7C65211A
USB Product ID	0x002	0x00FB
UART	Can be configured as Virtual COM port or USB vendor device	Can be configured as Virtual COM port or USB vendor device
I ² C	Can be configured as USB vendor device	Can be configured as Virtual COM port or USB vendor device
SPI	Can be configured as USB vendor device	Can be configured as Virtual COM port or USB vendor device
RS485 Support	No	Yes

2 Block diagram

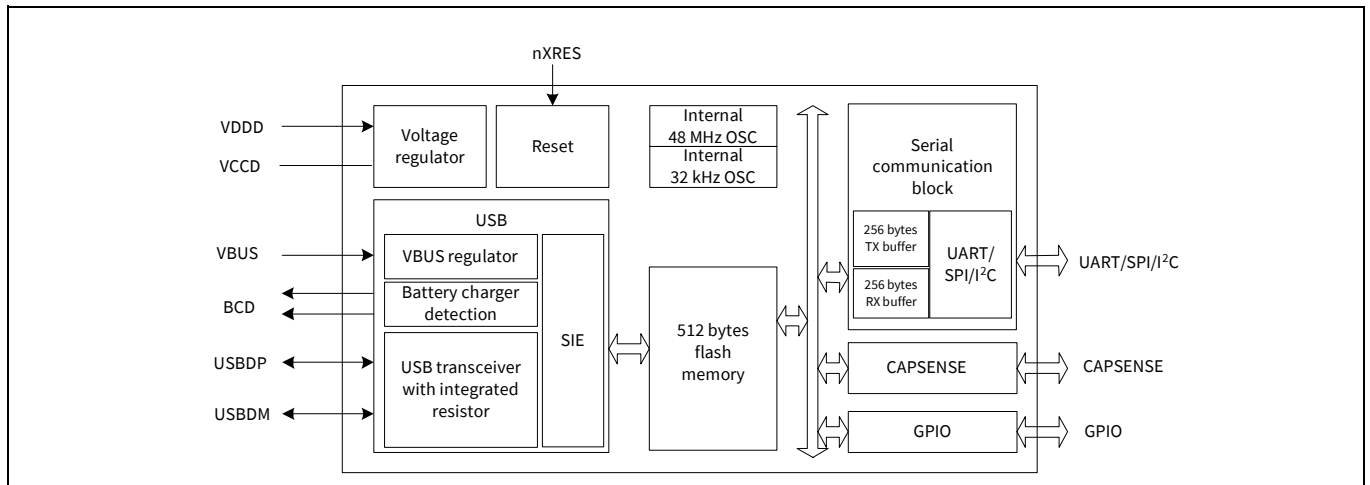

3 Functional overview

CY7C65211/CY7C65211A is a full-speed USB controller that enables seamless PC connectivity for peripherals with serial interfaces, such as UART, SPI, and I²C. CY7C65211/CY7C65211A also integrates CAPSENSE™ and BCD-compliant with the USB battery charging specification, rev. 1.2. It integrates a voltage regulator, an oscillator, and flash memory for storing configuration parameters, offering a cost-effective solution. CY7C65211 supports bus-powered and self-powered modes and enables efficient system power management with suspend and remote wake-up signals. It is available in a 24-pin QFN package.

3.1 USB and charger detect

3.1.1 USB

CY7C65211/CY7C65211A has a built-in USB 2.0 full-speed transceiver. The transceiver incorporates the internal USB series termination resistors on the USB data lines and a 1.5 kΩ pull-up resistor on USBDP.

3.1.2 Charger detection

CY7C65211/CY7C65211A supports BCD for peripheral detect only and complies with the USB battery charging specification, rev. 1.2. It supports the following charging ports:

- Standard downstream port (SDP): Allows the system to draw up to 500 mA current from the host
- Charging downstream port (CDP): Allows the system to draw up to 1.5 A current from the host
- Dedicated charging port (DCP): Allows the system to draw up to 1.5 A of current from the wall charger

3.2 Serial communication

CY7C65211/CY7C65211A has a serial communication block (SCB). Each SCB can implement UART, SPI, or I²C interface. A 256-byte buffer is available in both the TX and RX lines.

3.2.1 UART interface

The UART interface provides asynchronous serial communication with other UART devices operating at speeds of up to 3 Mbps. It supports 7 to 8 data bits, 1 to 2 stop bits, odd, even, mark, space, and no parity. The UART interface supports full-duplex communication with a signaling format that is compatible with the standard UART protocol. In CY7C65211, UART pins may be interfaced to industry standard RS232/RS422 transceivers whereas in CY7C65211A these UART pins may be interfaced to RS232/RS422/RS485.

Common UART functions, such as parity error and frame error, are supported. CY7C65211/CY7C65211A supports baud rates ranging from 300 baud to 3 Mbaud. The UART baud rates can be set using the configuration utility.

Notes:

- Parity error gets detected when UART transmitter device is configured for odd parity and UART receiver device is configured for even parity.
- Frame error gets detected when UART transmitter device is configured for 7 bits data width and 1 stop bit, whereas UART receiver device is configured for 8 bit data width and 2 stop bits.

3.2.2 UART flow control

CY7C65211 device supports UART hardware flow control using control signal pairs, such as request to send (RTS) / clear to send (CTS) and data terminal ready (DTR) / data set ready (DSR). Data flow control is enabled by default. Flow control can be disabled using the configuration utility.

The following section describes the flow control signals:

- CTS# (input) / RTS# (output)

CTS# can pause or resume data transmission over the UART interface. Data transmission can be paused by de-asserting the CTS signal and resumed with CTS# assertion. The pause and resume operation does not affect data integrity. With flow control enabled, receive buffer has a watermark level of 93%. After the data in the receive buffer reaches that level, the RTS# signal is de-asserted, instructing the transmitting device to stop data transmission. The start of data consumption by application reduces the device data backlog; when it reaches the 75% watermark level, the RTS# signal is asserted to resume data reception.

- DSR# (input) / DTR# (output)

The DSR#/DTR# signals are used to establish a communication link with the UART. These signals complement each other in their functionality, similar to CTS# and RTS#.

3.2.3 SPI interface

The SPI interface supports an SPI master and SPI slave. This interface supports the Motorola, TI, and National Microwire protocols. The maximum frequency of operation is 3 MHz in SPI master mode and 1 MHz in SPI slave mode. It can support transaction sizes ranging from 4 bits to 16 bits in length, SPI slave supports 4 bits to 8 bits and 12 bits to 16 bits data width at 1 MHz operation. Whereas, it supports 9 bits, 10 bits and 11 bits data width operation at 500 kHz operation. (see “[USB to SPI Bridge](#)” on page 33 for more details).

3.2.4 I²C interface

The I²C interface implements full multi-master/slave modes and supports up to 400 kHz. The configuration utility tool is used to set the I²C address in the slave mode. The tool enables only even slave addresses. For further details on the protocol, refer to the NXP I²C specification, rev. 5.

Notes:

- I²C ports are not tolerant of higher voltages. Therefore, they cannot be hot-swapped or powered up independently when chip is not powered.
- The minimum fall time of the SCL is met (as per NXP I2C specification rev. 5) when V_{DD} is between 1.71 V and 3.0 V. When V_{DD} is within the range of 3.0 V to 3.6 V, it is recommended to add a 50 pF capacitor on the SCL signal.

3.3 CAPSENSE™

CAPSENSE™ functionality is supported on all the GPIO pins. Any GPIO pin can be configured as a sense pin (CS0–CS7) using the configuration utility. When implementing CAPSENSE™ functionality, the GPIO_0 pin (configured as a modulator capacitor - Cmod) should be connected to ground through a 2.2 nF capacitor (see [Figure 13](#)).

CY7C65211 supports smart sensing algorithm for Auto-Tuning of the CAPSENSE™ parameters and does not require manual tuning. Smart sensing algorithm for Auto-tuning compensates for printed circuit board (PCB) variations and device process variations.

Optionally, any GPIO pin can be configured as a Cshield and connected to the shield of the CAPSENSE™ button, as shown in [Figure 13](#). Shield prevents false triggering of buttons due to water droplets and guarantees CAPSENSE™ operation (sensors respond to finger touch).

GPIOs can be linked to the CAPSENSE™ buttons to indicate the presence of a finger. CAPSENSE™ functionality can be configured using the configuration utility.

CY7C65211 supports up to five CAPSENSE™ buttons. For more information on CAPSENSE™, see [Getting Started with CAPSENSE™](#).

3.4 GPIO interface

CY7C65211/CY7C65211A has ten GPIOs. The maximum available GPIOs for configuration is ten if one two-pin (I2C/2-pin UART) serial interface is implemented. The configuration utility allows configuration of the GPIO pins. The configurable options are as follows:

- TRISTATE: GPIO tristated
- DRIVE 1: Output static 1
- DRIVE 0: Output static 0
- POWER#: Power control for bus power designs
- TXLED#: Drives LED during USB transmit
- RXLED#: Drives LED during USB receive
- TX or RX LED#: Drives LED during USB transmit or receive

GPIO can be configured to drive LED at 8 mA drive strength.

- BCD0/BCD1: Two-pin output to indicate the type of USB charger
- BUSDETECT: Connects the VBUS pin for USB host detection
- CS0–CS4: CAPSENSE™ button input (sense pin)
- CSout0–CSout2: Indicates which CapSense button is pressed
- Cmod: External modulator capacitor; connects a 2.2 nF capacitor ($\pm 10\%$) to ground (GPIO_0 only)
- Cshield: Shield for waterproofing

3.5 Memory

CY7C65211/CY7C65211A has a 512-byte flash. Flash is used to store USB parameters, such as VID/PID, serial number, product and manufacturer descriptors, which can be programmed by the configuration utility.

3.6 System resources

3.6.1 Power system

CY7C65211/CY7C65211A supports the USB Suspend mode to control power usage. CY7C65211 operates in bus-powered or self-powered modes over a range of 3.15 V to 5.5 V.

3.6.2 Clock system

CY7C65211/CY7C65211A has a fully integrated clock with no external components required. The clock system is responsible for providing clocks to all subsystems.

3.6.3 Internal 48-MHz oscillator

The internal 48-MHz oscillator is the primary source of internal clocking in CY7C65211.

3.6.4 Internal 32-kHz oscillator

The internal 32-kHz oscillator is primarily used to generate clocks for peripheral operation in the USB suspend mode.

3.6.5 Reset

The reset block ensures reliable power-on reset and brings the device back to the default known state. The nXRES (active low) pin can be used by the external devices to reset the CY7C65211/CY7C65211A.

3.7 Suspend and resume

CY7C65211/CY7C65211A device asserts the SUSPEND pin when the USB bus enters the suspend state. This helps in meeting the stringent suspend current requirement of the USB 2.0 specification, while using the device in bus-powered mode. The device resumes from the suspend state under either of the two following conditions:

- Any activity is detected on the USB bus
- The WAKEUP pin is asserted to generate remote wakeup to the host

3.8 Wakeup

The WAKEUP pin is used to generate the remote wakeup signal on the USB bus. The remote wakeup signal is sent only if the host enables this feature through the SET_FEATURE request. The device communicates support for the remote wakeup to the host through the configuration descriptor during the USB enumeration process. CY7C65211/CY7C65211A device allows enabling/disabling and polarity of the remote wakeup feature through the configuration utility.

3.9 Software

Infineon delivers a complete set of software drivers and a configuration utility to enable configuration of the product during system development.

3.9.1 Drivers for Linux operating systems

Infineon provides a User Mode USB driver library (*libcyusbserial.so*) that abstracts vendor commands for the UART interface and provides a simplified API interface for user applications. This library uses the standard open-source libUSB library to enable USB communication. The Cypress serial library supports the USB plug-and-play feature using the Linux ‘udev’ mechanism.

CY7C65211/CY7C65211A supports the standard USB CDC UART class driver, which is bundled with the Linux kernel.

3.9.2 Android support

CY7C65211/CY7C65211A solution includes an Android Java class–*CyUsbSerial.java*–which exposes a set of interface functions to communicate with the device.

3.9.3 Drivers for Mac OSx

Infineon delivers a dynamically linked shared library (*CyUSBSerial.dylib*) based on libUSB, which enables communication to the CY7C65211 device.

In addition, the CY7C65211 device also supports the native Mac OSx CDC UART driver, and CY7C65211A supports native Mac OSx CDC UART/SPI/I2C driver.

3.9.4 Drivers for Windows operating systems

For Windows operating systems (XP, Vista, Win7, Win 8, and Win 8.1), Infineon delivers a user-mode dynamically linked library–*CyUSBSerial.dll*–that abstracts a vendor-specific interface of the CY7C65211/CY7C65211A devices and provides convenient APIs to the user. It provides interface APIs for vendor-specific UART/SPI/I2C and class-specific APIs for PHDC.

USB-Serial Bridge Controller works with the Windows-standard USB CDC class driver, when either CY7C65211 is configured as CDC USB to UART device or when CY7C65211A is configured as CDC USB to UART/SPI/I2C device. A virtual COM port driver–*CyUSBSerial.sys*–is also delivered, which implements the USB CDC class driver. The Infineon Windows drivers are Windows hardware certification kit-compliant.

These drivers are bound to device through WU (Windows Update) services.

Infineon drivers also support Windows plug-and-play and power management and USB remote wake-up.

3.9.5 Windows-CE support

CY7C65211/CY7C65211A solution includes a CDC UART driver library for Windows-CE platforms.

Device configuration utility (Windows only)

A Windows-based configuration utility is available to configure device initialization parameters. This graphical user application provides an interactive interface to define the boot parameters stored in the device flash.

This utility allows the user to save a user-selected configuration to text or xml formats. It also allows users to load a selected configuration from text or xml formats. The configuration utility allows the following operations:

- View current device configuration
- Select and configure UART/I2C/SPI, CAPSENSE™, battery charging, and GPIOs
- Configure USB VID, PID, and string descriptors
- Save or Load configuration

You can download the free configuration utility and drivers at www.infineon.com.

3.10 Internal flash configuration

The internal flash memory can be used to store the configuration parameters shown in the following table. A free configuration utility is provided to configure the parameters listed in the table to meet application-specific requirements over the USB interface. The configuration utility can be downloaded at www.infineon.com/usbserial.

Table 2 Internal flash configuration for both CY7C65211 and CY7C65211A

Parameter	Default value	Description
USB configuration		
USB vendor ID (VID)	0x04B4	Default Infineon VID. Can be configured to customer VID.
USB product ID (PID)	0x0002 for CY7C65211 and 0x00FB for CY7C65211A	Default Infineon PID. Can be configured to customer PID.
Manufacturer string	Infineon	Can be configured with any string up-to 64 characters.
Product string	USB-Serial (single channel)	Can be configured with any string up-to 64 characters.
Serial string		Can be configured with any string up-to 64 characters.
Power mode	Bus powered	Can be configured to bus-powered or self-powered mode.
Max current draw	100 mA	Can be configured to any value from 0 mA to 500 mA. The configuration descriptor will be updated based on this.
Remote wakeup	Enabled	Can be disabled. Remote wakeup is initiated by asserting the WAKEUP pin.
USB interface protocol	CDC	Can be configured to function in CDC, PHDC, or Infineon vendor class.
BCD	Disabled	Charger detect is disabled by default. When BCD is enabled, three of the GPIOs must be configured for BCD.
GPIO configuration		
GPIO_0	TXLED#	GPIO can be configured as shown in Table 18 .
GPIO_1	RXLED#	
GPIO_2	DSR#	
GPIO_3	RTS#	
GPIO_4	CTS#	
GPIO_5	TxD	
GPIO_6	RxD	
GPIO_7	DTR#	
GPIO_8	TRISTATE	
GPIO_9	TRISTATE	
GPIO_10	TRISTATE	
GPIO_11	POWER#	

4 Electrical specifications

4.1 Absolute maximum ratings

Exceeding maximum ratings^[1] may shorten the useful life of the device.

Table 3 Absolute maximum ratings

Parameter	Maximum ratings
Storage temperature (Industrial, commercial)	-55°C to +100°C
Storage temperature (Automotive)	-55°C to +150°C
Ambient temperature with power supplied (Industrial, commercial)	-40°C to +85°C
Ambient temperature with power supplied (Automotive)	-40°C to +105°C
Supply voltage to ground potential	
V _{DDD}	6.0 V
V _{BUS}	6.0 V
V _{CCD}	1.95 V
V _{GPIO}	V _{DDD} + 0.5 V
Static discharge voltage ESD protection levels:	
HBM per JESD22-A114	2.2 kV
Latch-up current	140 mA
Current per GPIO	25 mA

4.2 Operating conditions

Table 4 Operating conditions

Parameter	Operating conditions
T _A (ambient temperature under bias)	
Industrial	-40°C to +85°C
Automotive	-40°C to +105°C
V _{BUS} supply voltage	3.15 V to 5.25 V
V _{DDD} supply voltage	1.71 V to 5.50 V
V _{CCD} supply voltage	1.71 V to 1.89 V

Note

- Usage above the absolute maximum conditions may cause permanent damage to the device. Exposure to absolute maximum conditions for extended periods of time may affect device reliability. When used below absolute maximum conditions but above normal operating conditions, the device may not operate to specification.

4.3 Device-level specifications

All specifications are valid for $-40^{\circ}\text{C} \leq T_A \leq 85^{\circ}\text{C}$, $T_J \leq 100^{\circ}\text{C}$, and 1.71 V to 5.50 V, except where noted.

Table 5 DC specifications

Parameter	Description	Min	Typ	Max	Unit	Details/conditions
V _{BUS}	V _{BUS} supply voltage	3.15	3.30	3.45	V	Set and configure the correct voltage range using a configuration utility for V _{BUS} . Default 5 V.
		4.35	5.00	5.25	V	
V _{DDD}	V _{DDD} supply voltage	1.71	1.80	1.89	V	Used to set I/O and core voltage. Set and configure the correct voltage range using a configuration utility for V _{DDD} . Default 3.3 V.
		2.0	3.3	5.5	V	
V _{CCD}	Output voltage (for core logic)	–	1.80	–	V	Do not use this supply to drive the external device. <ul style="list-style-type: none"> • 1.71 V ≤ V_{DDD} ≤ 1.89 V: Short the V_{CCD} pin with the V_{DDD} pin • V_{DDD} > 2 V – connect a 1-μF capacitor (C_{efc}) between the V_{CCD} pin and ground
C _{efc}	External regulator voltage bypass	1.00	1.30	1.60	μF	X5R ceramic or better
I _{DD1}	Operating supply current	–	20	–	mA	USB 2.0 FS, UART at 1-Mbps single channel, no GPIO switching.
I _{DD2}	USB Suspend supply current	–	5	–	μA	Does not include current through a pull-up resistor on USBDP. In USB Suspend mode, the D+ voltage can go up to a maximum of 3.8 V.

Table 6 AC specifications

Parameter	Description	Min	Typ	Max	Unit	Details/conditions
Z _{out}	USB driver output impedance	28	–	44	W	–
T _{wakeup}	Wakeup from USB Suspend mode	–	25	–	μs	–

4.3.1 GPIO

Table 7 GPIO DC specifications

Parameter	Description	Min	Typ	Max	Unit	Details/conditions
V _{IH} ^[2]	Input voltage high threshold	0.7 × V _{DDD}	–	–	V	CMOS input
V _{IL}	Input voltage low threshold	–	–	0.3 × V _{DDD}	V	CMOS input
V _{IH} ^[2]	LVTTL input, V _{DDD} < 2.7 V	0.7 × V _{DDD}	–	–	V	–
V _{IL}	LVTTL input, V _{DDD} < 2.7V	–	–	0.3 × V _{DDD}	V	–
V _{IH} ^[2]	LVTTL input, V _{DDD} ≥ 2.7V	2	–	–	V	–
V _{IL}	LVTTL input, V _{DDD} ≥ 2.7V	–	–	0.8	V	–
V _{OH}	CMOS output voltage high level	V _{DDD} – 0.4	–	–	V	I _{OH} = 4 mA, V _{DDD} = 5 V +/- 10%
V _{OH}	CMOS output voltage high level	V _{DDD} – 0.6	–	–	V	I _{OH} = 4 mA, V _{DDD} = 3.3 V +/- 10%
V _{OH}	CMOS output voltage high level	V _{DDD} – 0.5	–	–	V	I _{OH} = 1 mA, V _{DDD} = 1.8 V +/- 5%
V _{OL}	CMOS output voltage low level	–	–	0.4	V	I _{OL} = 8 mA, V _{DDD} = 5 V +/- 10%
V _{OL}	CMOS output voltage low level	–	–	0.6	V	I _{OL} = 8 mA, V _{DDD} = 3.3 V +/- 10%
V _{OL}	CMOS output voltage low level	–	–	0.6	V	I _{OL} = 4 mA, V _{DDD} = 1.8 V +/- 5%
R _{pullup}	Pull-up resistor	3.5	5.6	8.5	kΩ	–
R _{pulldown}	Pull-down resistor	3.5	5.6	8.5	kΩ	–
I _{IL}	Input leakage current (absolute value)	–	–	2	nA	25°C, V _{DDD} = 3.0 V
C _{IN}	Input capacitance	–	–	7	pF	–
V _{hystttl}	Input hysteresis LVTTL; V _{DDD} > 2.7 V	25	40	C	mV	–
V _{hyscmos}	Input hysteresis CMOS	0.05 × V _{DDD}	–	–	mV	–

Note

2. V_{IH} must not exceed V_{DDD} + 0.2 V.

Table 8 GPIO AC specifications

Parameter	Description	Min	Typ	Max	Unit	Details/conditions
T _{RiseFast1}	Rise Time in Fast mode	2	–	12	ns	V _{DDD} = 3.3 V/ 5.5 V, Cl _{oad} = 25 pF
T _{FallFast1}	Fall Time in Fast mode	2	–	12	ns	V _{DDD} = 3.3 V/ 5.5 V, Cl _{oad} = 25 pF
T _{RiseSlow1}	Rise Time in Slow mode	10	–	60	ns	V _{DDD} = 3.3 V/ 5.5 V, Cl _{oad} = 25 pF
T _{FallSlow1}	Fall Time in Slow mode	10	–	60	ns	V _{DDD} = 3.3 V/ 5.5 V, Cl _{oad} = 25 pF
T _{RiseFast2}	Rise Time in Fast mode	2	–	20	ns	V _{DDD} = 1.8 V, Cl _{oad} = 25 pF
T _{FallFast2}	Fall Time in Fast mode	20	–	100	ns	V _{DDD} = 1.8 V, Cl _{oad} = 25 pF
T _{RiseSlow2}	Rise Time in Slow mode	2	–	20	ns	V _{DDD} = 1.8 V, Cl _{oad} = 25 pF
T _{FallSlow2}	Fall Time in Slow mode	20	–	100	ns	V _{DDD} = 1.8 V, Cl _{oad} = 25 pF

4.3.2 nXRES

Table 9 nXRES DC specifications

Parameter	Description	Min	Typ	Max	Unit	Details/conditions
V _{IH}	Input voltage high threshold	0.7 × V _{DDD}	–	–	V	–
V _{IL}	Input voltage low threshold	–	–	0.3 × V _{DDD}	V	–
R _{pullup}	Pull-up resistor	3.5	5.6	8.5	kΩ	–
C _{IN}	Input capacitance	–	5	–	pF	–
V _{hysxres}	Input voltage hysteresis	–	100	–	mV	–

Table 10 nXRES AC specifications

Parameter	Description	Min	Typ	Max	Unit	Details/conditions
T _{resetwidth}	Reset pulse width	1	–	–	μs	–

4.4 Digital peripherals

4.4.1 UART

Table 11 UART AC specifications

Parameter	Description	Min	Typ	Max	Unit	Details/conditions
F _{UART}	UART bit rate	0.3	–	3000	kbps	–

4.4.2 SPI

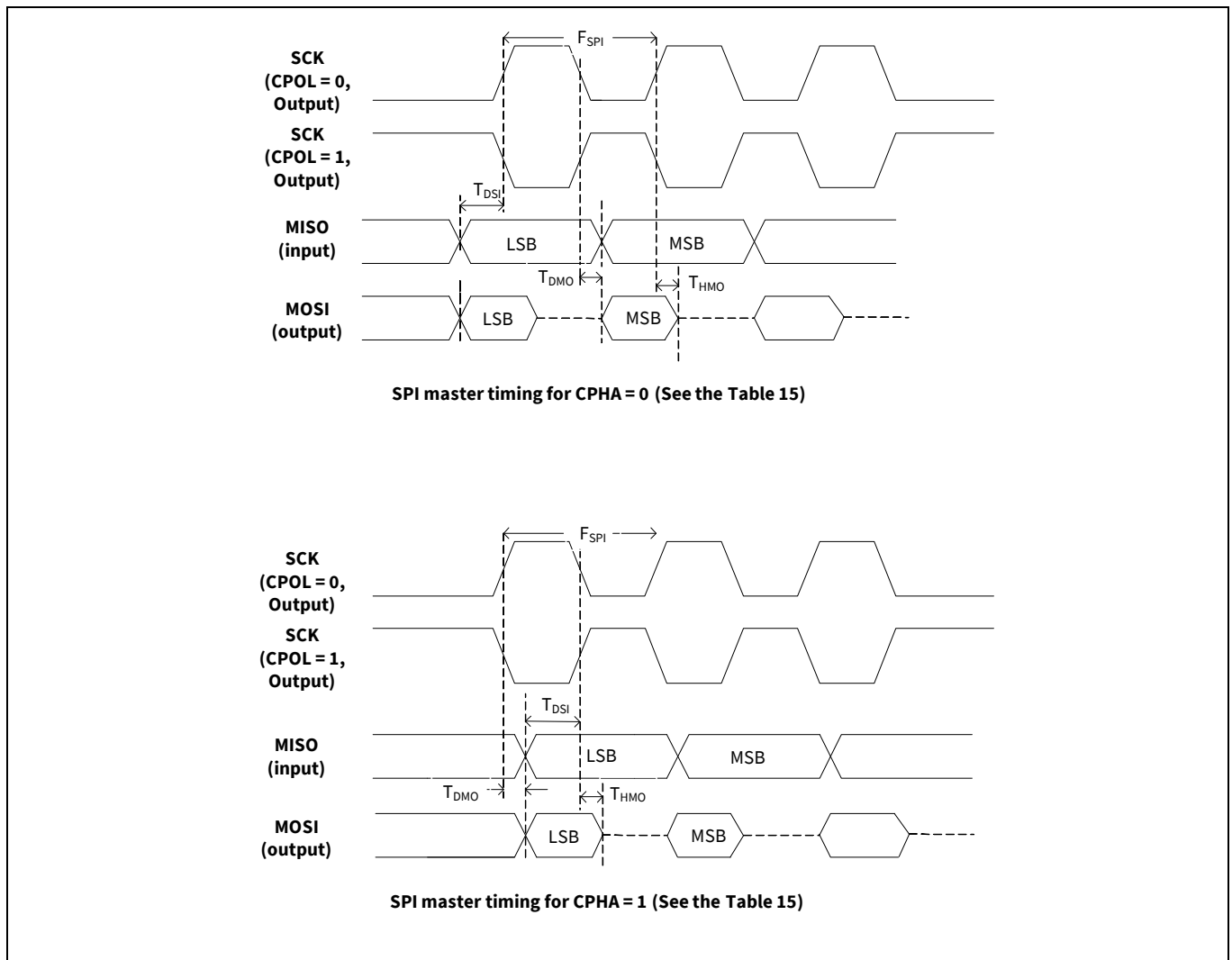

Figure 1 SPI master timing

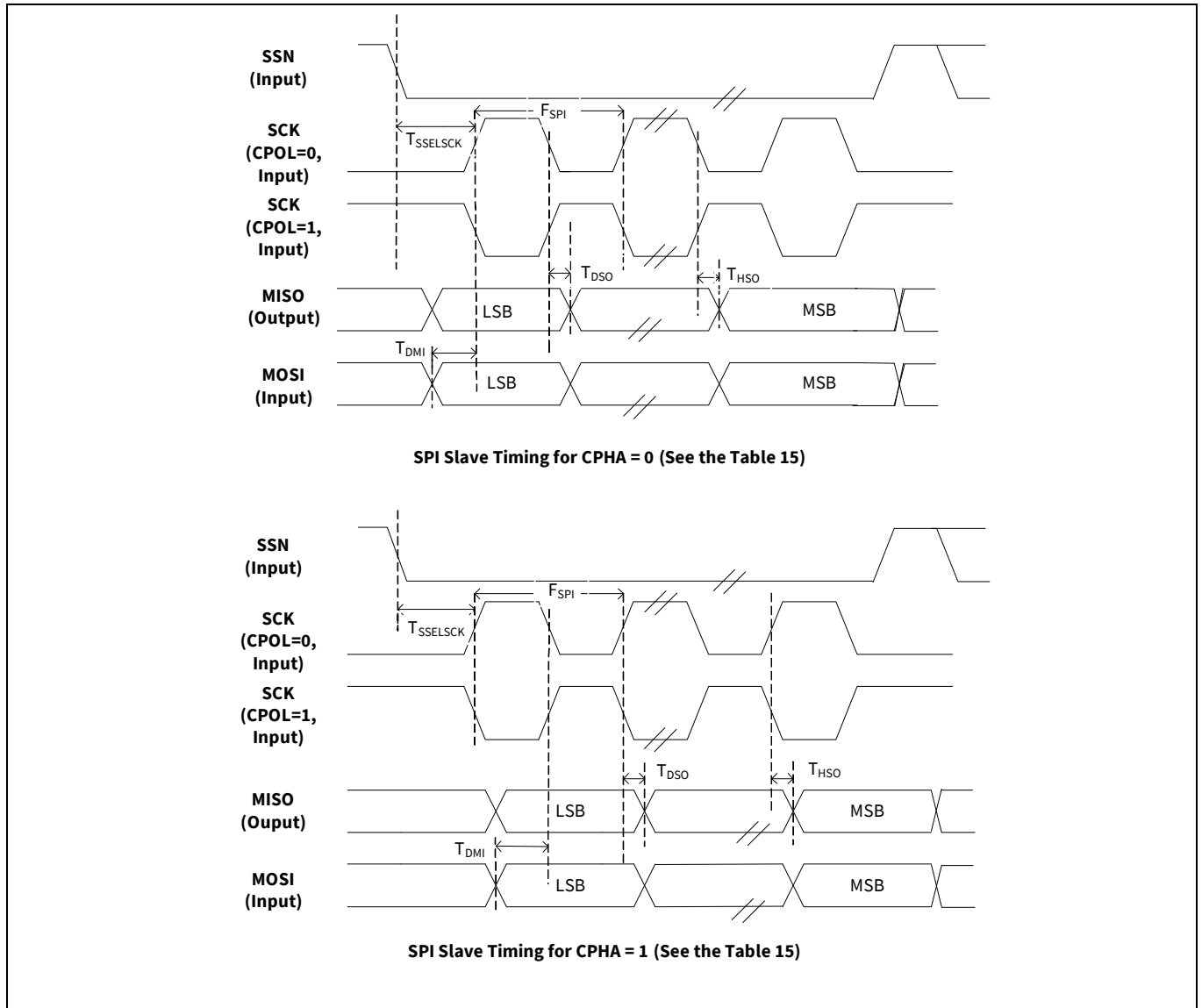

Figure 2 SPI slave timing

Table 12 SPI AC specifications

Parameter	Description	Min	Typ	Max	Unit	Details/conditions
F _{SPI}	SPI operating frequency (Master/Slave)	–	–	3	MHz	–
WL _{SPI}	SPI word length	4	–	16	bits	–
SPI Master mode						
T _{DMO}	MOSI valid after SClock driving edge	–	–	15	ns	–
T _{DSI}	MISO valid before SClock capturing edge	20	–	–	ns	–
T _{HMO}	Previous MOSI data hold time with respect to capturing edge at slave	0	–	–	ns	–
SPI Slave mode						
T _{DMI}	MOSI valid before Sclock capturing edge	40	–	–	ns	–
T _{DSO}	MISO valid after Sclock driving edge	–	–	104.4	ns	–
T _{HSO}	Previous MISO data hold time	0	–	–	ns	–
T _{SSELSCK}	SSEL valid to first SCK Valid edge	100	–	–	ns	–

4.4.3 I²C

Table 13 I²C AC specifications

Parameter	Description	Min	Typ	Max	Unit	Details/conditions
F _{I2C}	I ² C frequency	1	–	400	kHz	–

4.5 CAPSENSE™

Table 14 CAPSENSE™ AC specifications

Parameter	Description	Min	Typ	Max	Unit	Details/conditions
V _{CSD}	Voltage range of operation	1.71	–	5.50	V	–
SNR	Ratio of counts of finger to noise	5	–	–	Ratio	Sensor capacitance range of 9 pF to 35 pF; finger capacitance ≥ 0.1 pF sensitivity

4.6 System resources

4.6.1 Memory

Table 15 Flash memory specifications

Parameter	Description	Min	Typ	Max	Unit	Details/conditions
F _{end}	Flash endurance	100K	–	–	cycles	–
F _{ret}	Flash retention. T _A ≤ 85°C, 10K program/erase cycles	10	–	–	years	–

5 Pin description

Table 16 Pin description

Pin ^[3]	Type	Name	Default	Description	
1	SCB/GPIO	SCB_0	GPIO_6	RxD	SCB/GPIO. See Table 17 and Table 18 .
2	SCB/GPIO	SCB_5	GPIO_7	DTR#	SCB/GPIO. See Table 17 and Table 18 .
3	Power	VSSD	–	Digital ground	
4	GPIO	GPIO_8	TRISTATE	GPIO. See Table 18 .	
5	GPIO	GPIO_9	TRISTATE	GPIO. See Table 18 .	
6	GPIO	GPIO_10	TRISTATE	GPIO. See Table 18 .	
7	GPIO	GPIO_11	POWER#	GPIO. See Table 18 .	
8	Output	SUSPEND	–	Indicates device in suspend mode. Can be configured as active low/high using the configuration utility.	
9	Input	WAKEUP	–	Wakeup device from suspend mode. Can be configured as active low/high using the configuration utility.	
10	USBIO	USBDP	–	USB Data Signal Plus, integrates termination resistor and a 1.5-kΩ pull-up resistor	
11	USBIO	USBDM	–	USB Data Signal Minus, integrates termination resistor	
12	Power	VCCD	–	This pin should be decoupled to ground using a 1-μF capacitor or by connecting a 1.8-V supply.	
13	Power	VSSD	–	Digital ground	
14	nXRES	nXRES	–	Chip reset, active low. Can be left unconnected or have a pull-up resistor connected if not used.	
15	Power	VBUS	–	VBUS Supply, 3.15 V to 5.25 V	
16	Power	VSSD	–	Digital ground	
17	Power	VSSA	–	Analog ground	
18	GPIO	GPIO_0	TXLED#	GPIO. See Table 18 .	
19	GPIO	GPIO_1	RXLED#	GPIO. See Table 18 .	
20	SCB/GPIO	SCB_1	GPIO_2	DSR#	SCB/GPIO. See Table 17 and Table 18 .
21	SCB/GPIO	SCB_2	GPIO_3	RTS#	SCB/GPIO. See Table 17 and Table 18 .
22	SCB/GPIO	SCB_3	GPIO_4	CTS#	SCB/GPIO. See Table 17 and Table 18 .
23	SCB/GPIO	SCB_4	GPIO_5	TxD	SCB/GPIO. See Table 17 and Table 18 .
24	Power	VDDD	–	Supply to the device core and Interface, 1.71 V to 5.5 V	

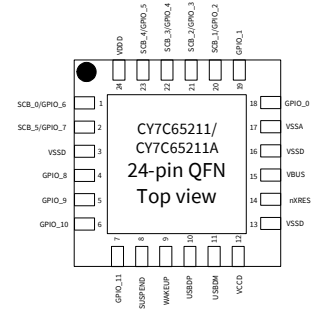

Note

3. Any pin acting as an Input pin should not be left unconnected.

Pin description

Table 17 Serial communication block configuration

Pin	Serial Port	Mode 0 ^[4]	Mode 1	Mode 2	Mode 3	Mode 4	Mode 5	Mode 6
		6-pin UART	4-pin UART	2-pin UART	SPI Master	SPI Slave	I2C Master	I2C Slave
1	SCB_0	RxD	RxD	RxD	GPIO_6	GPIO_6	GPIO_6	GPIO_6
20	SCB_1	DSR#	GPIO_2	GPIO_2	SSEL_OUT	SSEL_IN	GPIO_2	GPIO_2
21	SCB_2	RTS#	RTS#	GPIO_3	MISO_IN	MISO_OUT	SCL_OUT	SCL_IN
22	SCB_3	CTS#	CTS#	GPIO_4	MOSI_OUT	MOSI_IN	SDA	SDA
23	SCB_4	TxD	TxD	TxD	SCLK_OUT	SCLK_IN	GPIO_5	GPIO_5
2	SCB_5	DTR#	GPIO_7	GPIO_7	GPIO_7	GPIO_7	GPIO_7	GPIO_7

Note

4. The device is configured in Mode 0 as the default. Other modes can be configured using the configuration utility provided by Infineon.

Table 18 GPIO configuration

GPIO configuration option	Description
TRISTATE	I/O tristated
DRIVE 1	Output static 1
DRIVE 0	Output static 0
POWER#	This output is used to control power to an external logic through a switch to cut power off during an unconfigured USB device and USB Suspend. 0 - USB device in Configured state 1 - USB device in Unconfigured state or during USB Suspend mode
TXLED#	Drives LED during USB transmit
RXLED#	Drives LED during USB receive
TX or RX LED#	Drives LED during USB transmit or receive
BCD0 BCD1	Configurable battery charger detect pins to indicate the type of USB charger (SDP, CDP, or DCP) Configuration example: 00 - Draw up to 100 mA (unconfigured state) 01 - SDP (up to 500 mA) 10 - CDP/DCP (up to 1.5 A) 11 - Suspend (up to 2.5 mA) This truth table can be configured using a configuration utility
BUSDETECT	VBUS detection. Connect the VBUS to this pin through a resistor network for VBUS detection when using the BCD feature.
CS0, CS1, CS2, CS3, CS4	CAPSENSE™ button input (max up to 5)
CSout0, CSout1, CSout2	Indicates which CAPSENSE™ button is pressed
CMOD (Available on GPIO_0 only)	External modulator capacitor, connect a 2.2 nF capacitor (±10%) to ground
Cshield (optional)	Shield for waterproofing

Note: These signal options can be configured on any of the available GPIO pins using the configuration utility provided by Infineon.

6 USB power configurations

The following section describes possible USB power configurations for the CY7C65211/CY7C65211A. See the “[Pin description](#)” on page 22 for signal details.

6.1 USB bus-powered configuration

Figure 3 shows an example of the CY7C65211/CY7C65211A in a bus-powered design. The VBUS is connected directly to the CY7C65211 because it has an internal regulator.

The USB bus-powered system must comply with the following requirements:

- The system should not draw more than 100 mA prior to USB enumeration (Unconfigured state)
- The system should not draw more than 2.5 mA during the USB Suspend mode
- A high-power bus-powered system (can draw more than 100 mA when operational) must use POWER# (configured over GPIO) to keep the current consumption below 100 mA prior to USB enumeration, and 2.5 mA during USB Suspend state
- The system should not draw more than 500 mA from the USB host

The configuration descriptor in the CY7C65211/CY7C65211A flash should be updated to indicate bus power and the maximum current required by the system using the configuration utility.

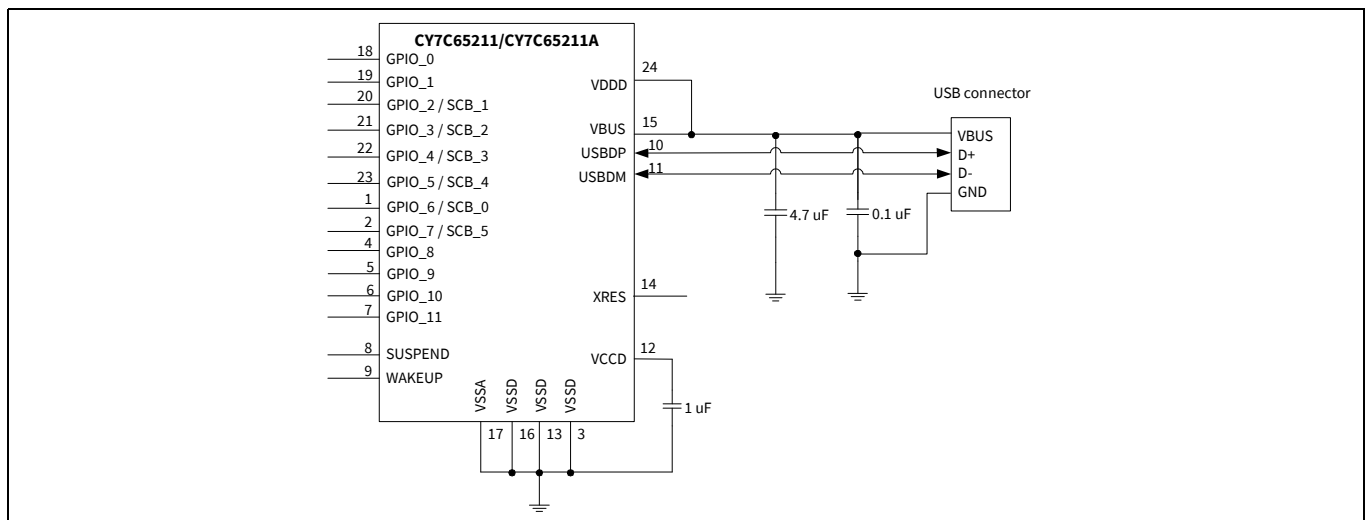

Figure 3 Bus-powered configuration

6.2 Self-powered configuration

Figure 4 shows an example of CY7C65211/CY7C65211A in a self-powered design. A self-powered system does not use the VBUS from the host to power the system, but it has its own power supply. A self-powered system has no restriction on current consumption because it does not draw any current from the VBUS.

When the VBUS is present, CY7C65211/CY7C65211A enables an internal, 1.5-kΩ pull-up resistor on USBDP. When the VBUS is absent (USB host is powered down), CY7C65211/CY7C65211A removes the 1.5-kΩ pull-up resistor on USBDP. This ensures that no current flows from the USBDP to the USB host through a 1.5-kΩ pull-up resistor, to comply with the USB 2.0 specification.

When reset is asserted to CY7C65211/CY7C65211A, all the I/O pins are tristated.

The configuration descriptor in the CY7C65211/CY7C65211A flash should be updated to indicate self-power using the configuration utility.

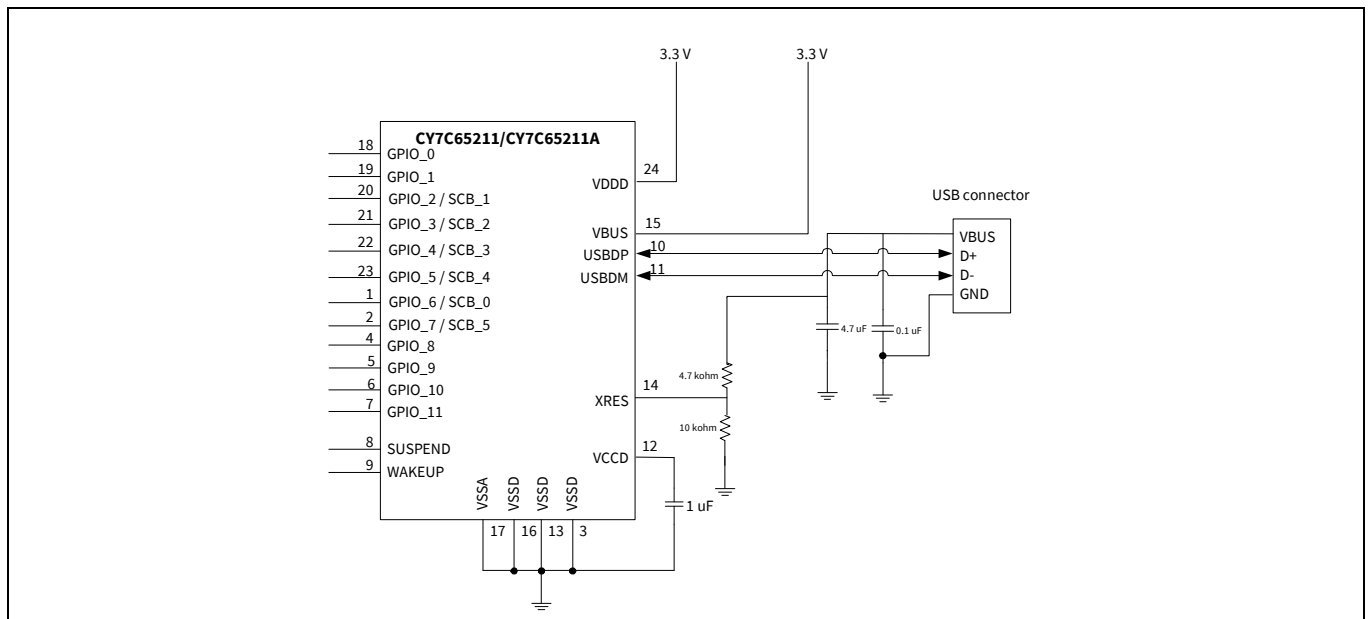

Figure 4 Self-powered configuration

6.3 USB bus-powered with variable I/O voltage

Figure 5 shows CY7C65211/CY7C65211A in a bus-powered system with variable I/O voltage. A low dropout (LDO) regulator is used to supply 1.8 V or 3.3 V, using a jumper switch the input of which is 5 V from the VBUS. Another jumper switch is used to select 1.8/3.3 V or 5 V from the VBUS for the VDDD pin of CY7C65211. This allows I/O voltage and supply to external logic to be selected among 1.8 V, 3.3 V, or 5 V.

The USB bus-powered system must comply with the following conditions:

- The system should not draw more than 100 mA prior to USB enumeration (unconfigured state)
- The system should not draw more than 2.5 mA during USB Suspend mode
- A high-power bus-powered system (can draw more than 100 mA when operational) must use POWER# (configured over GPIO) to keep the current consumption below 100 mA prior to USB enumeration and 2.5 mA during the USB Suspend state

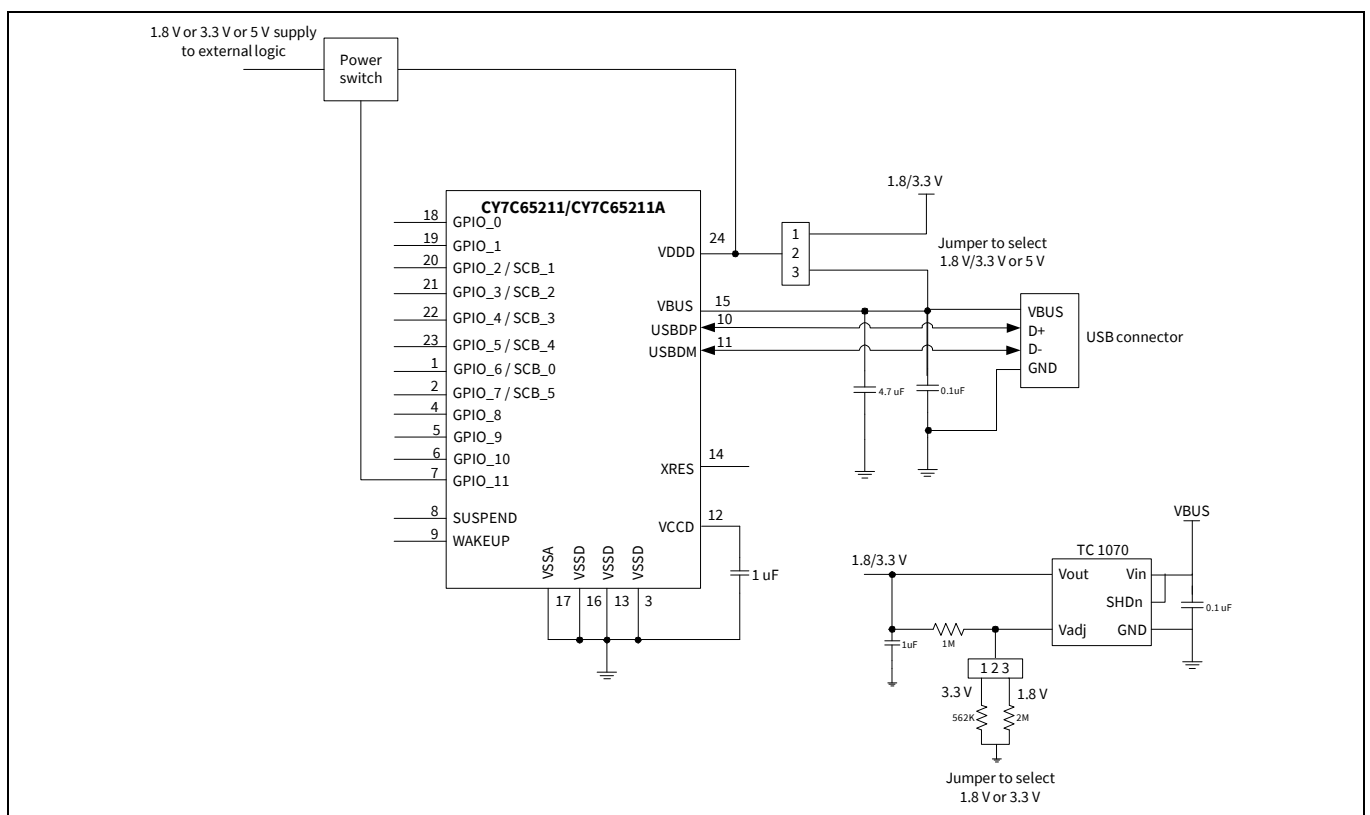

Figure 5 USB bus-powered with 1.8-V, 3.3-V, or 5-V variable I/O voltage [5]

Note

1. $1.71 \text{ V} \leq \text{VDDD} \leq 1.89 \text{ V}$ - Short VCCD pin with VDDD pin; $\text{VDDD} > 2 \text{ V}$ - connect a 1-μF decoupling capacitor to the VCCD pin.

7 Application examples

The following section provides CY7C65211/CY7C65211A application examples.

7.1 USB to RS232 bridge

CY7C65211/CY7C65211A can connect any embedded system, with a serial port, to a host PC through USB. CY7C65211/CY7C65211A enumerates as a COM port on the host PC.

The RS232 protocol follows bipolar signaling – that is, the output signal toggles between negative and positive polarity. The valid RS232 signal is either in the -3 V to -15 V range or in the $+3\text{ V}$ to $+15\text{ V}$ range, and the range between -3 V to $+3\text{ V}$ is invalid. In the RS232, Logic 1 is called “Mark” and it corresponds to a negative voltage range. Logic 0 is called “Space” and it corresponds to a positive voltage range. The RS232 level converter facilitates this polarity inversion and the voltage-level translation between the CY7C65211/CY7C65211A’s UART interface and RS232 signaling.

In this application, as shown in **Figure 6**, SUSPEND is connected to the SHDN# pin of the RS232-level converter to indicate USB suspend or USB not enumerated.

GPIO8 and GPIO9 are configured as RXLED# and TXLED# to drive two LEDs, indicating data transmit and receive.

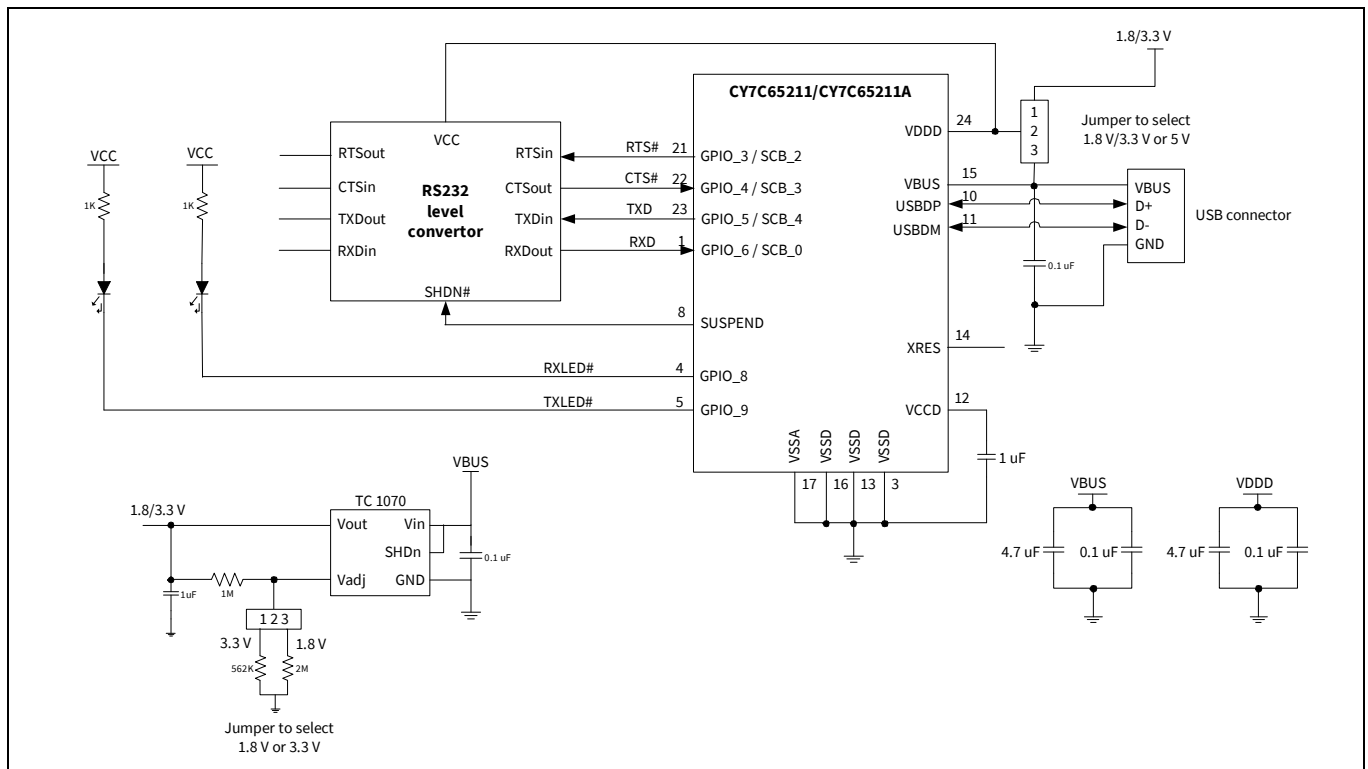

Figure 6 USB to RS232 bridge

7.3 Battery-operated, bus-powered USB to MCU with battery charge detection

Figure 9 illustrates CY7C65211/CY7C65211A as a USB-to-microcontroller interface. The TXD and RXD lines are used for data transfer, and the RTS# and CTS# lines are used for handshaking. The SUSPEND pin indicates to the MCU if the device is in USB Suspend, and the WAKEUP pin is used to wake up CY7C65211/CY7C65211A, which in turn issues a remote wakeup to the USB host.

This application illustrates a battery-operated system, which is bus-powered. CY7C65211/CY7C65211A implements the battery charger detection functionality based on the USB battery charging specification, rev. 1.2. Battery-operated bus power systems must comply with the following conditions:

- The system can be powered from the battery (if not discharged) and can be operational if the VBUS is not connected or powered down
- The system should not draw more than 100 mA from the VBUS prior to USB enumeration and USB Suspend
- The system should not draw more than 500 mA for SDP and 1.5 A for CDP/DCP

To comply with the first requirement, the VBUS from the USB host is connected to the battery charger as well as to CY7C65211, as shown in **Figure 9**. When the VBUS is connected, CY7C65211 initiates battery charger detection and indicates the type of USB charger over BCD0 and BCD1. If the USB charger is SDP or CDP, CY7C65211 enables a 1.5-K Ω pull-up resistor on the USBDP for Full-Speed enumeration. When the VBUS is disconnected, CY7C65211 indicates an absence of the USB charger over BCD0 and BCD1, and removes the 1.5-K Ω pull-up resistor on USBDP. Removing this resistor ensures that no current flows from the supply to the USB host through the USBDP, to comply with the USB 2.0 specification.

To comply with the second and third requirements, two signals (BCD0 and BCD1) are configured over GPIO to communicate the type of USB host charger and the amount of current it can draw from the battery charger. BCD0 and BCD1 signals can be configured using the configuration utility.

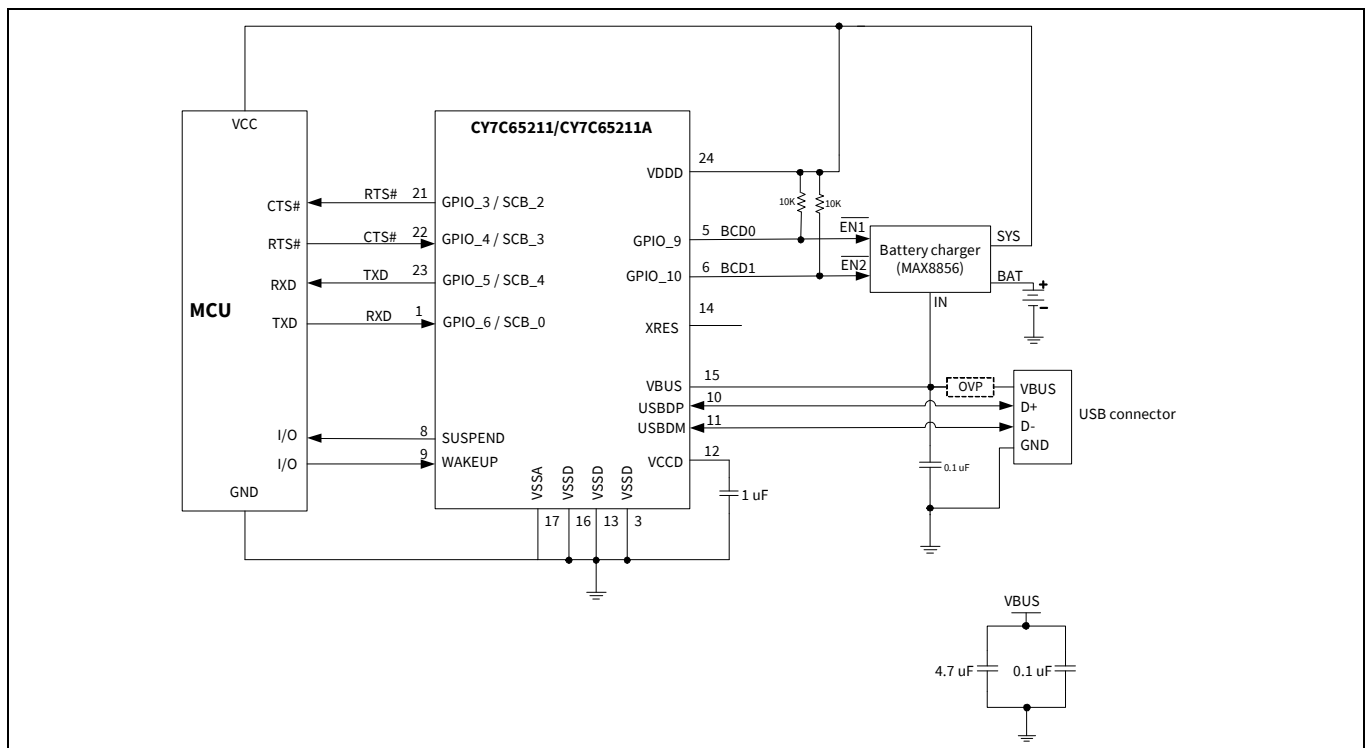

Figure 9 USB to MCU interface with battery charge detection [6]

Note

6. Add a 100-k Ω pull-down resistor on the V_{BUS} pin for quick discharge.

In a battery charger system, a 9 V spike on the VBUS is possible. The CY7C65211 VBUS pin is intolerant to voltage above 6 V. In the absence of over-voltage protection (OVP) on the VBUS line, the VBUS should be connected to BUSDETECT (GPIO configured) using the resistive network and the output of the battery charger to the VBUS pin of CY7C65211, as shown in **Figure 10**.

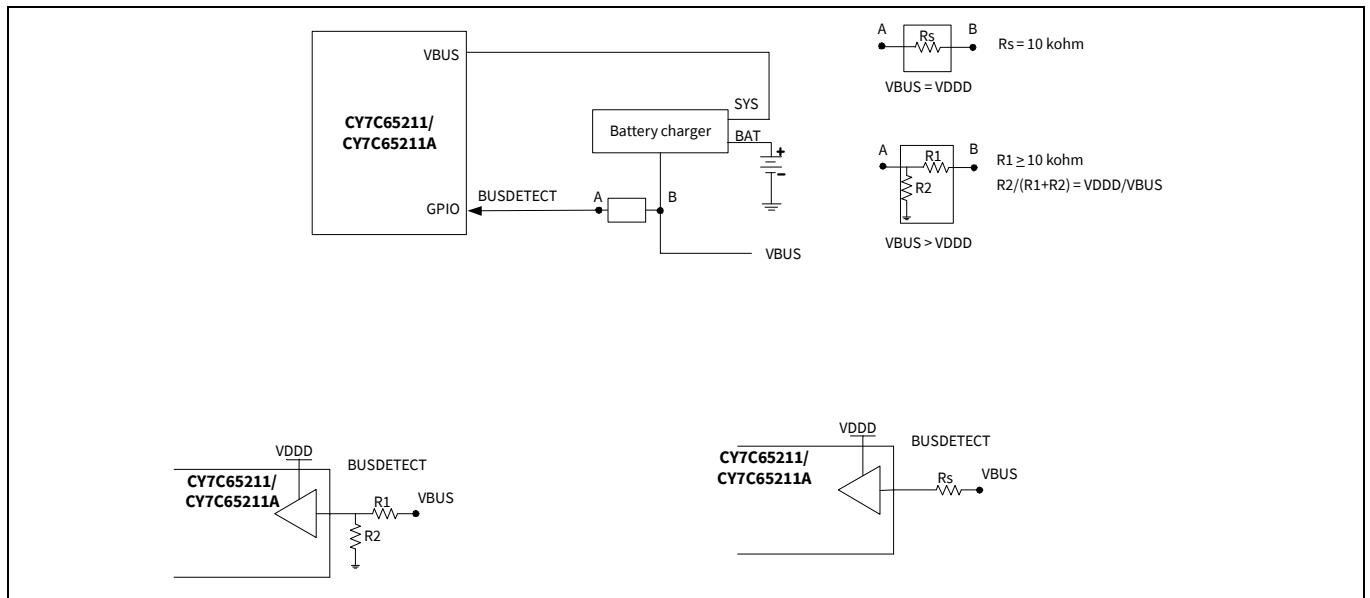

Figure 10 9 V tolerant

When the VBUS and VDDD are at the same voltage potential, the VBUS can be connected to the GPIO using a series resistor (R_s). This is shown in **Figure 11**. If there is a charger failure and the VBUS becomes 9 V, then the 10-k Ω resistor plays two roles. It reduces the amount of current flowing into the forward-biased diodes in the GPIO, and it reduces the voltage seen on the pad.

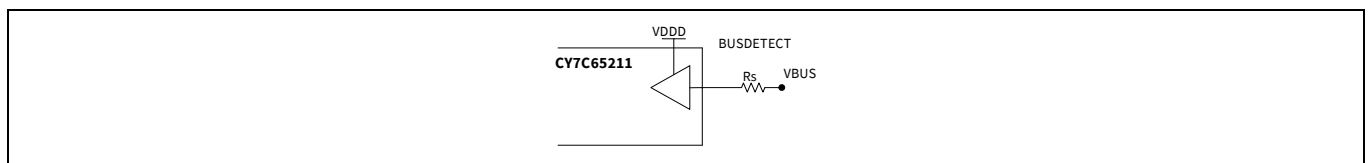

Figure 11 GPIO VBUS detection, VBUS = VDDD

When the VBUS > VDDD, a resistor voltage divider is required to reduce the voltage from the VBUS down to VDDD for the GPIO sensing the VBUS voltage. This is shown in **Figure 12**. The resistors should be sized as follows:

- $R_1 \geq 10 \text{ k}\Omega$
- $R_2 / (R_1 + R_2) = V_{DDD} / V_{BUS}$

The first condition limits the voltage and current for the charger failure situation, as described in the previous paragraph, while the second condition allows for normal-operation VBUS detection.

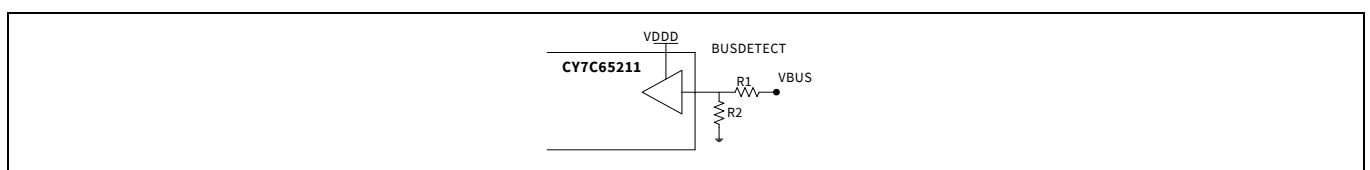

Figure 12 GPIO VBUS detection, VBUS > VDDD

7.4 CAPSENSE™

In **Figure 13**, CY7C65211 is configured to support four CAPSENSE™ buttons. Three GPIOs are configured to indicate which CAPSENSE™ button is pressed by the finger (as shown in the table next to the schematic). If two CAPSENSE™ buttons are implemented, then two GPIOs (CSout0 and CSout1) are configured to indicate which CAPSENSE™ button is pressed.

A 2.2 nF (10%) capacitor (Cmod) must be connected on the GPIO_0 pin for proper CAPSENSE™ operation.

Optionally, the GPIO_7 pin is configured as Cshield and connected to the shield of the CAPSENSE™ button, as shown in **Figure 13**.

Shield prevents false triggering of buttons due to water droplets, and guarantees CAPSENSE™ operation (the sensors respond to finger touch).

For further information on CAPSENSE™, see **Getting Started with CAPSENSE™**.

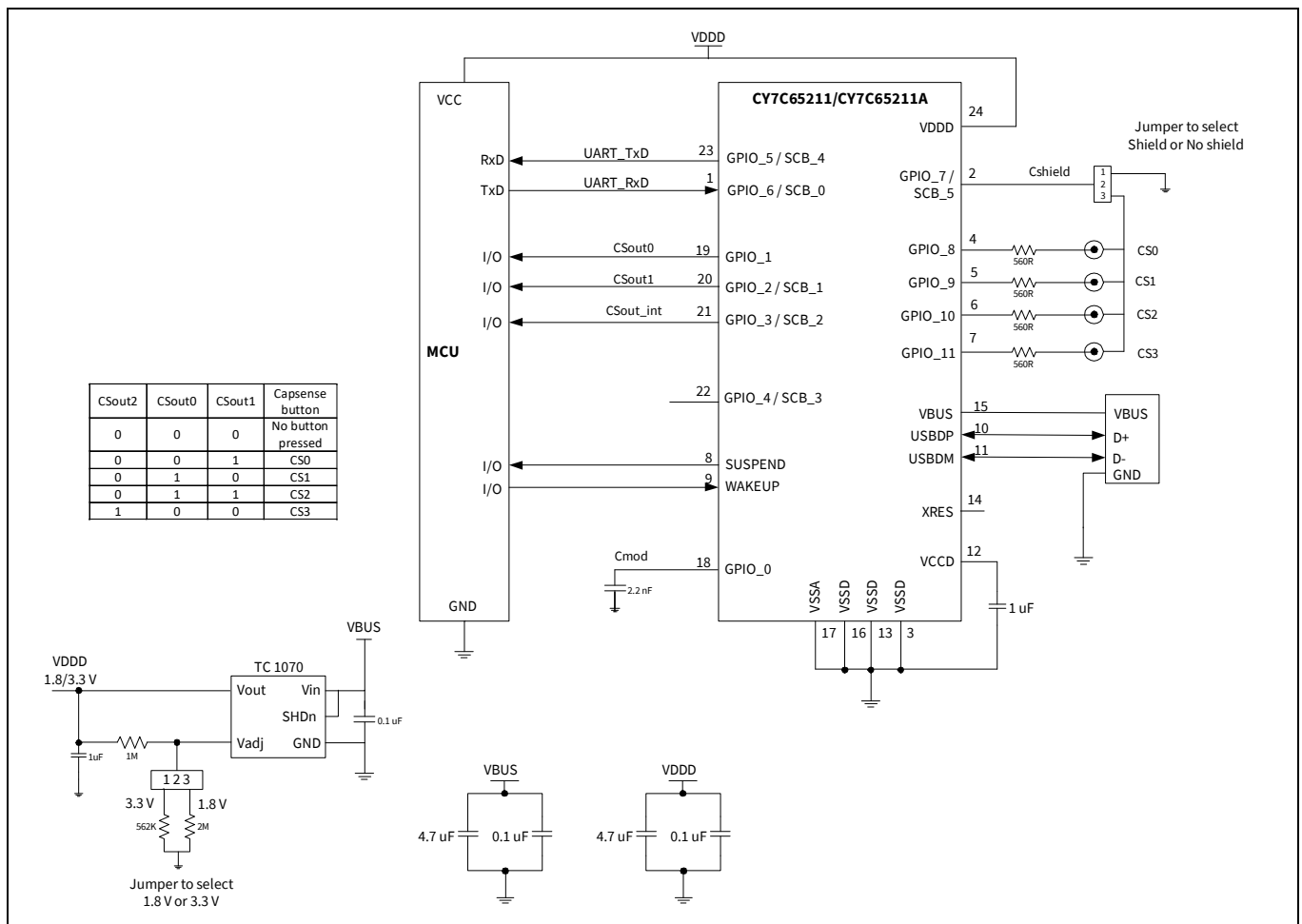

Figure 13 CAPSENSE™ schematic

7.5 USB to I²C bridge

In **Figure 14**, CY7C65211 is configured as a USB to I²C bridge. The CY7C65211 I²C can be configured as a master or a slave using the configuration utility. CY7C65211 supports I²C data rates up to 100 kbps in the standard mode (SM) and 400 kbps in the fast mode (FM).

In the Master mode, SCL is output from CY7C65211. In the slave mode, SCL is input to CY7C65211. The I²C slave address for CY7C65211 can be configured using the configuration utility. The SDA data line is bi-directional in the master/slave modes. The drive modes of the SCL and SDA port pins are always open drain.

GPIO8 and GPIO9 are configured as RXLED# and TXLED# to drive two LEDs to indicate USB receive and transmit. See the NXP I²C specification for further details on the protocol.

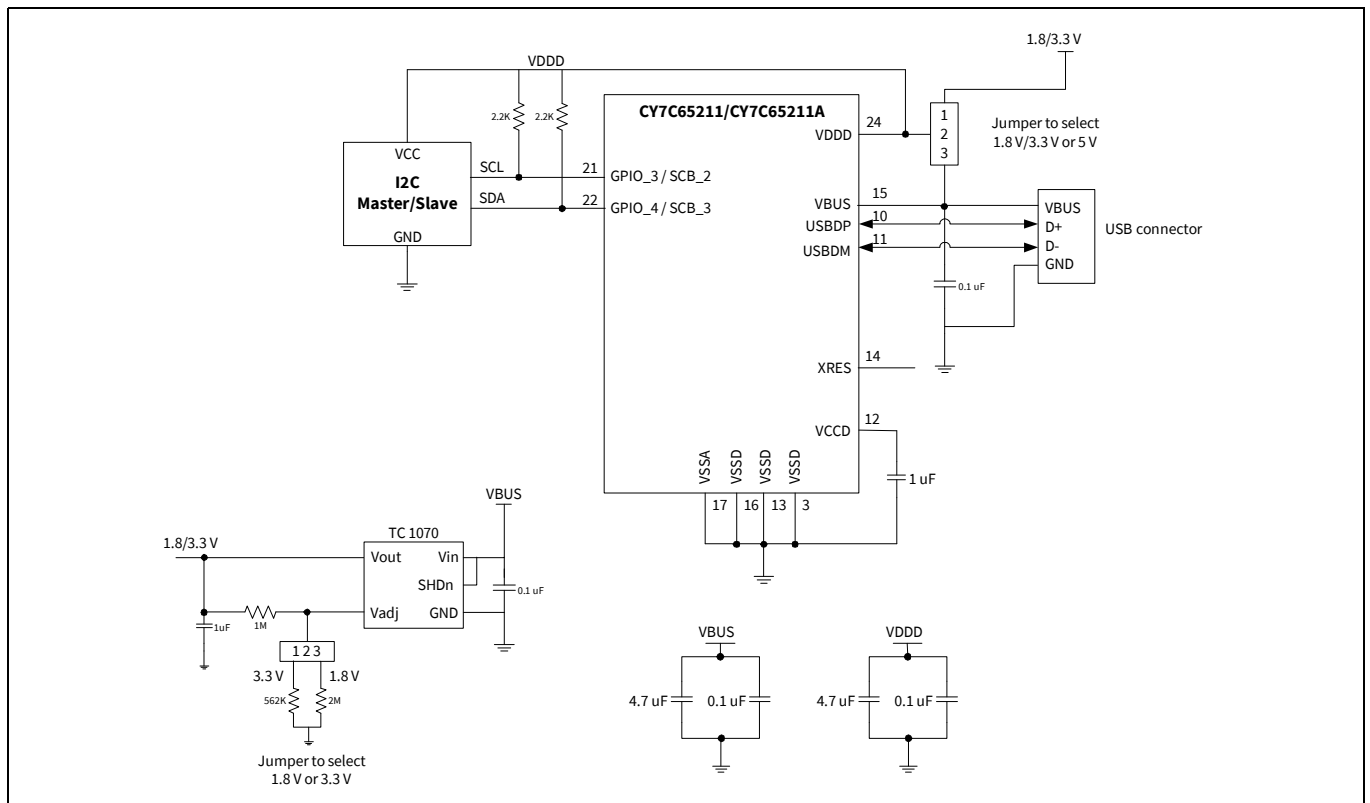

Figure 14 USB to I²C bridge

7.6 USB to SPI Bridge

In **Figure 15**, CY7C65211 is configured as a USB to SPI Bridge. The CY7C65211 SPI can be configured as a master or a slave using the configuration utility. CY7C65211 supports SPI master frequency up to 3 MHz and SPI slave frequency up to 1 MHz. It can support transaction sizes ranging from 4 bits to 16 bits, which can be configured using the configuration utility.

In the Master mode, the SCLK, MOSI, and SSEL lines act as outputs and MISO acts as an input. In the slave mode, the SCL, SCLK, MOSI, and SSEL lines act as inputs and MISO acts as an output.

GPIO8 and GPIO9 are configured as RXLED# and TXLED# to drive two LEDs to indicate USB receive and transmit.

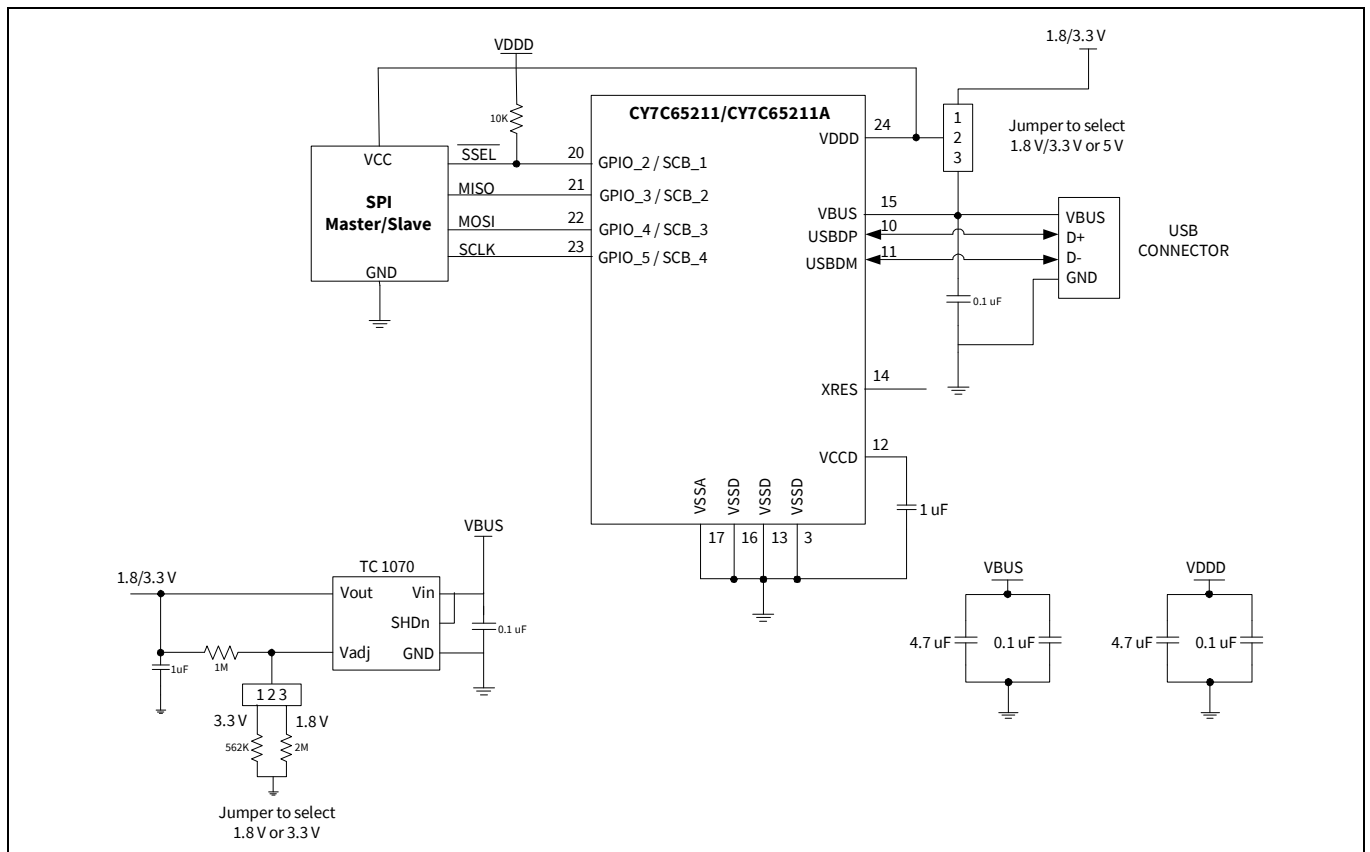

Figure 15 USB to SPI bridge

CY7C65211 supports three versions of the SPI protocol:

- Motorola - This is the original SPI protocol.
- Texas Instruments - A variation of the original SPI protocol in which the data frames are identified by a pulse on the SSEL line.
- National Semiconductors - A half-duplex variation of the original SPI protocol.

Motorola

The original SPI protocol is defined by Motorola. It is a full-duplex protocol: transmission and reception occur at the same time.

A single (full-duplex) data transfer follows these steps: The master selects a slave by driving its SSEL line to '0'. It then drives the data on its MOSI line and it drives a clock on its SCLK line. The slave uses the edges of the transmitted clock to capture the data on the MOSI line. The slave drives data on its MISO line. The master captures the data on the MISO line. Repeat the process for all bits in the data transfer.

Multiple data transfers may happen without the SSEL line changing from '0' to '1' and back from '1' to '0' in between the individual transfers. As a result, slaves must keep track of the progress of data transfers to separate individual transfers.

When not transmitting data, the SSEL line is '1' and the SCLK is typically off.

The Motorola SPI protocol has four modes that determine how data is driven and captured on the MOSI and MISO lines. These modes are determined by clock polarity (CPOL) and clock phase (CPHA). The clock polarity determines the value of the SCLK line when not transmitting data:

- CPOL is '0': SCLK is '0' when not transmitting data.
- CPOL is '1': SCLK is '1' when not transmitting data.

The clock phase determines when data is driven and captured. It is dependent on the value of CPOL:

Table 19 SPI protocol modes

Mode	CPOL	CPHA	Description
0	0	0	Data is driven on a falling edge of SCLK. Data is captured on a rising edge of SCLK.
1	0	1	Data is driven on a rising edge of SCLK. Data is captured on a falling edge of SCLK.
2	1	0	Data is driven on a rising edge of SCLK. Data is captured on a falling edge of SCLK.
3	1	1	Data is driven on a falling edge of SCLK. Data is captured on a rising edge of SCLK.

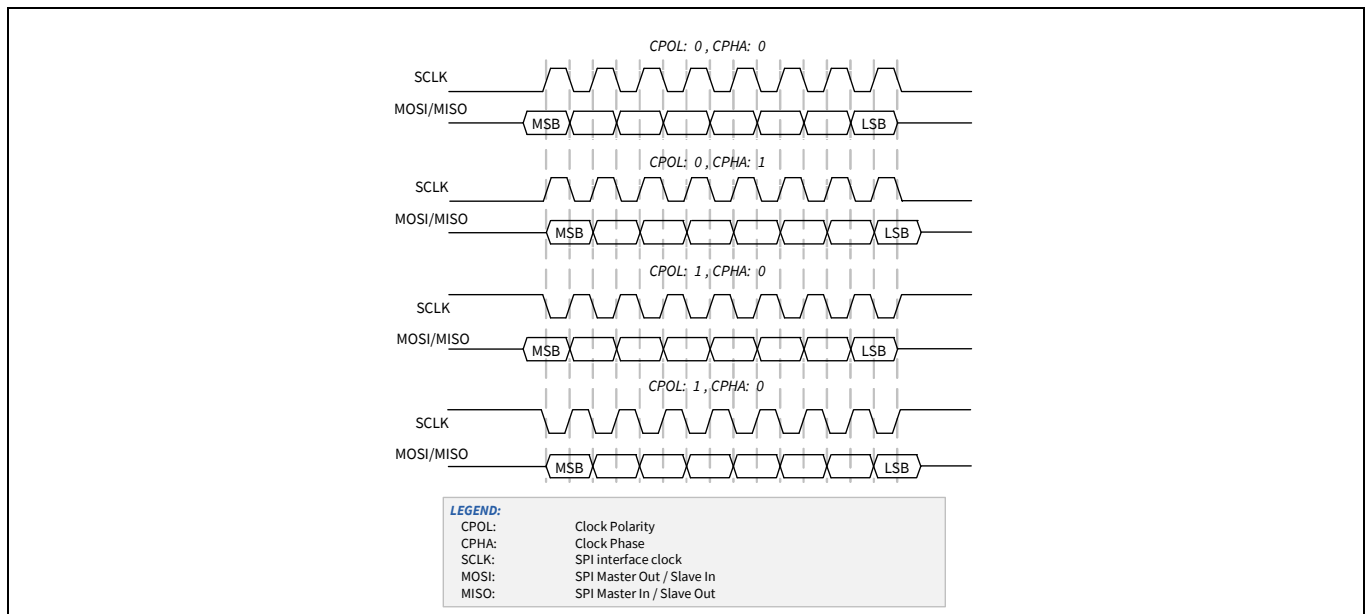

Figure 16 Driving and capturing MOSI/MISO data as a function of CPOL and CPHA

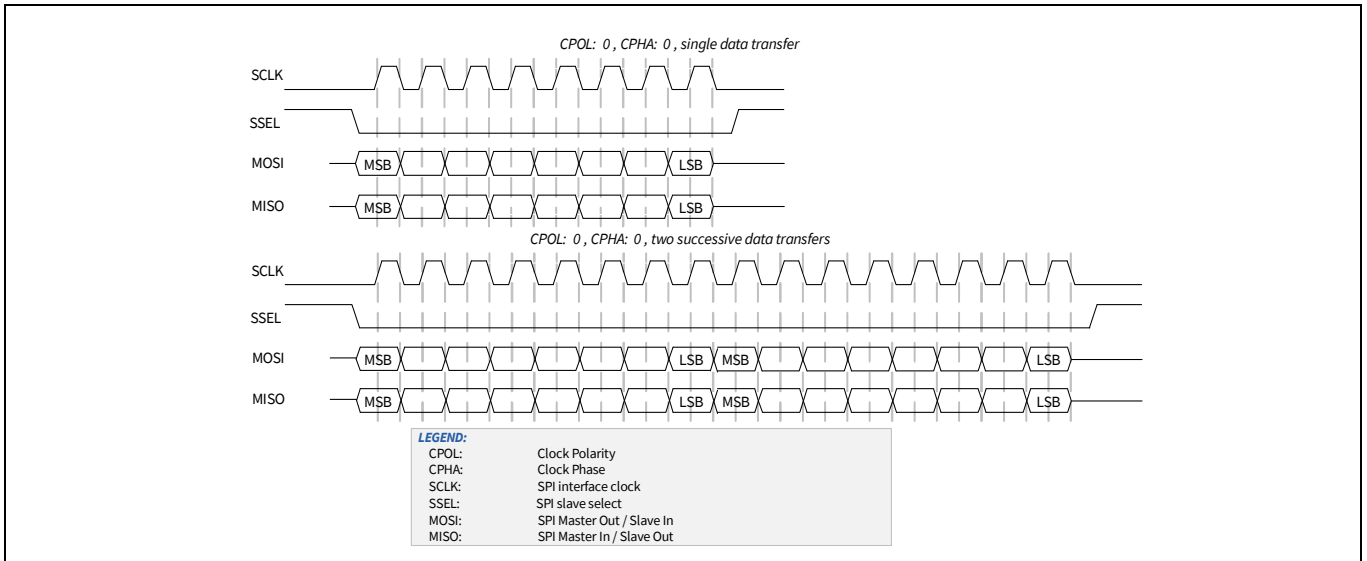

Figure 17 Single 8-bit data transfer and two successive 8-bit data transfers in Mode 0 (CPOL is '0', CPHA is '0')

Texas Instruments

Texas Instruments' SPI protocol redefines the use of the SSEL signal. It uses the signal to indicate the start of a data transfer, rather than a low, active slave-select signal. The start of a transfer is indicated by a high, active pulse of a single-bit transfer period. This pulse may occur one cycle before the transmission of the first data bit, or it may coincide with the transmission of the first data bit. The transmitted clock SCLK is a free-running clock. The TI SPI protocol only supports mode 1 (CPOL is '0' and CPHA is '1'): Data is driven on a rising edge of SCLK and data is captured on a falling edge of SCLK.

Figure 18 illustrates a single 8-bit data transfer and two successive 8-bit data transfers. The SSEL pulse precedes the first data bit. Note how the SSEL pulse of the second data transfer coincides with the last data bit of the first data transfer.

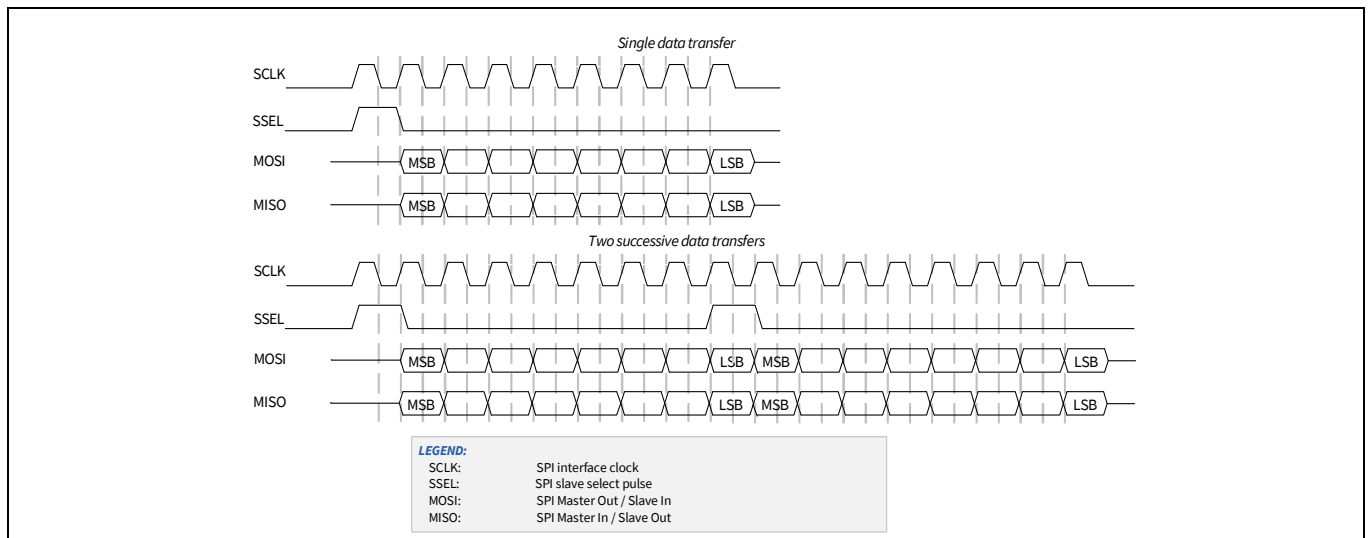

Figure 18 Single 8-bit data transfer and two successive 8-bit data transfers

Figure 19 illustrates a single 8-bit data transfer and two successive 8-bit data transfers. The SSEL pulse coincides with the first data bit.

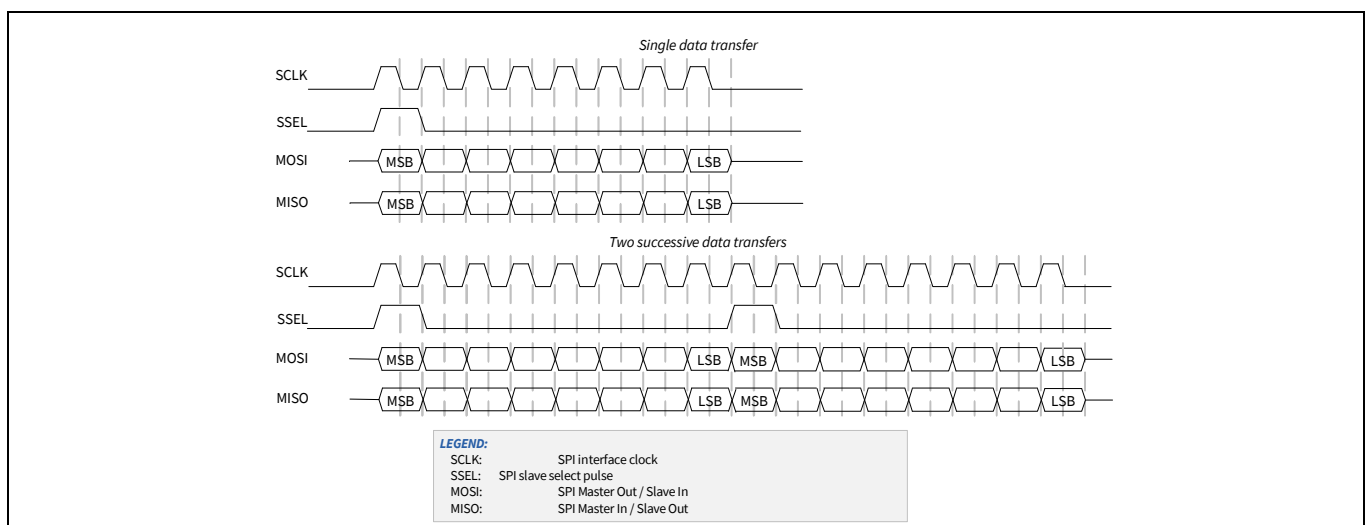

Figure 19 Single 8-bit data transfer and two successive 8-bit data transferst

National Semiconductor

National Semiconductor’s SPI protocol is a half-duplex protocol. Rather than transmission and reception occurring at the same time, they take turns (transmission happens before reception). A single “idle” bit transfer period separates transmission from reception.

Note: Successive data transfers are NOT separated by an “idle” bit transfer period.

The transmission data transfer size and reception data transfer size may differ. National Semiconductor’s SPI protocol supports only mode 0: Data is driven on a falling edge of SCLK, and data is captured on a rising edge of SCLK.

Figure 20 illustrates a single data transfer and two successive data transfers. In both cases, the transmission data transfer size is 8 bits and the reception transfer size is 4 bits.

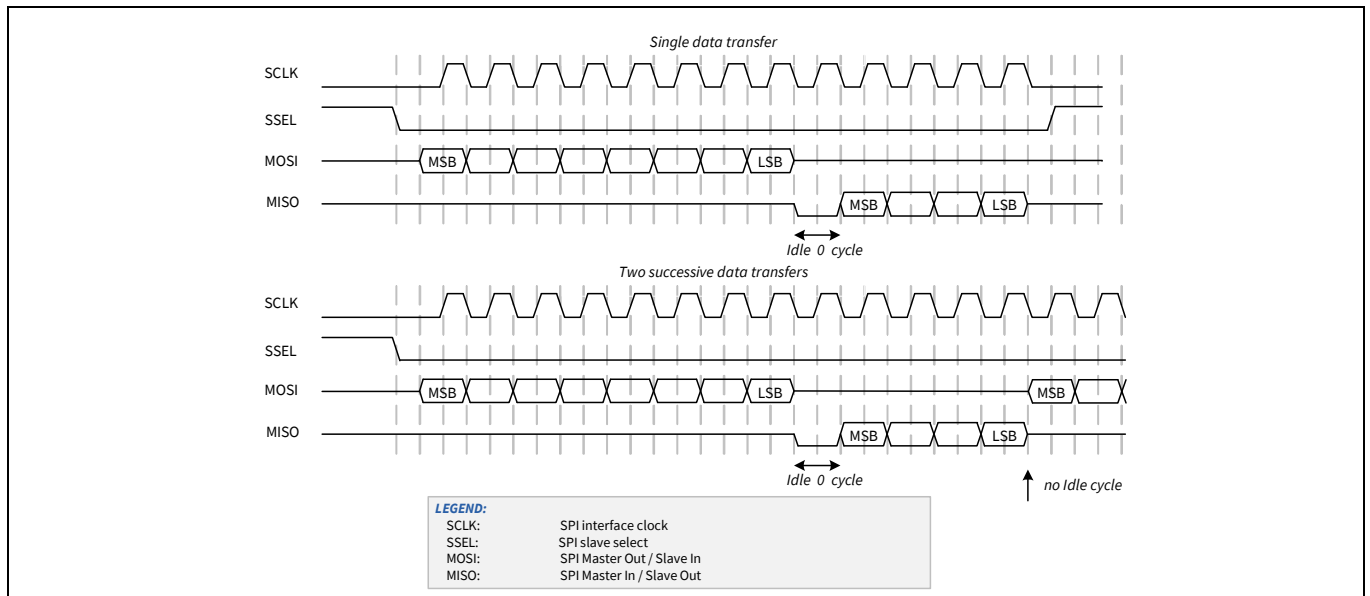

Figure 20 Single data transfer and two successive data transfers

Note: The above figure defines MISO and MOSI as undefined when the lines are considered idle (not carrying valid information). It will drive the outgoing line values to ‘0’ during idle time (to satisfy the requirements of specific master devices (NXP LPC17xx) and specific slave devices (MicroChip EEPROM)).

8 Ordering information

Table 20 lists the key package features and ordering codes of the CY7C65211. For more information, contact your local sales representative.

Table 20 Key features and ordering information

Package	Product	Operating range
24-lead QFN (4.00 × 4.00 × 0.55 mm, 0.5 mm pitch) (Pb-free)	CY7C65211-24LTXI	Industrial
24-lead QFN (4.00 × 4.00 × 0.55 mm, 0.5 mm pitch) (Pb-free) – tape and reel	CY7C65211-24LTXIT	Industrial
24-lead QFN (4.00 × 4.00 × 0.55 mm, 0.5 mm pitch) (Pb-free)	CY7C65211A-24LTXI	Industrial
24-lead QFN (4.00 × 4.00 × 0.55 mm, 0.5 mm pitch) (Pb-free) – tape and reel	CY7C65211A-24LTXIT	Industrial
24-lead QFN (4.00 × 4.00 × 0.55 mm, 0.5 mm pitch) (Pb-free)	CY7C65211A-24LQXS	Automotive
24-lead QFN (4.00 × 4.00 × 0.55 mm, 0.5 mm pitch) (Pb-free) – tape and reel	CY7C65211A-24LQXST	Automotive

8.1 Ordering code definitions

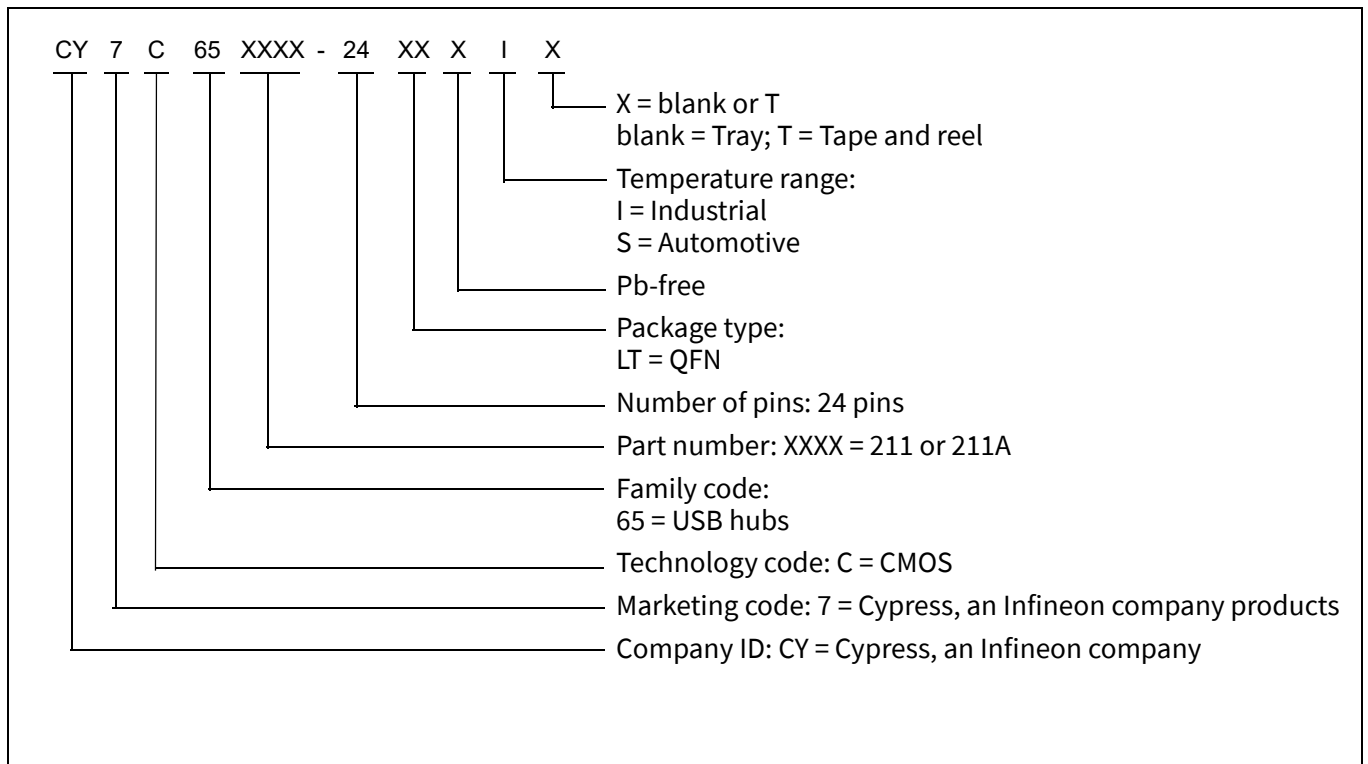

9 Package information

Support currently is planned for the 24-lead QFN package.

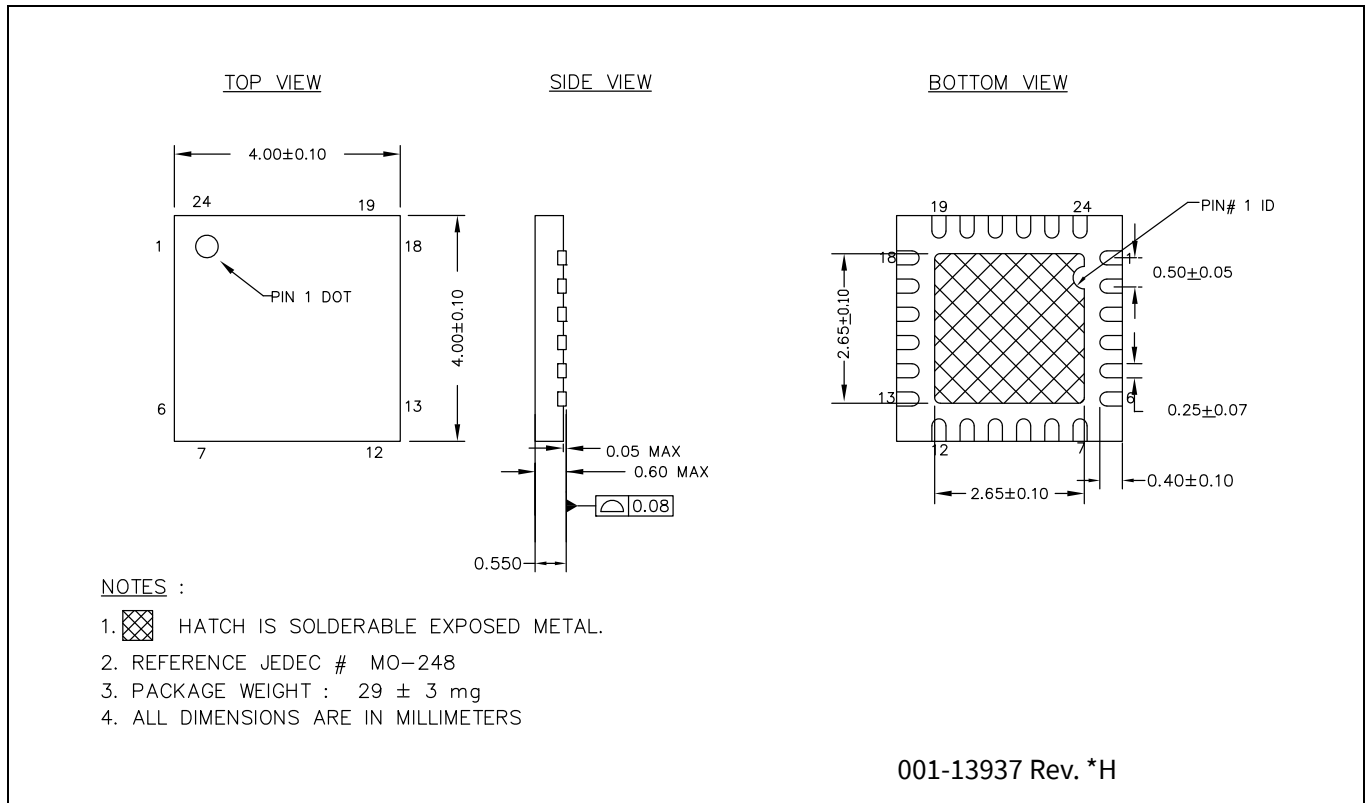

Figure 21 24-Lead QFN ((4 × 4 × 0.60 mm) LQ24A/LQ24B 2.65 × 2.65 E-Pad (Sawn)) package outline (PG-VQFN-24), 001-13937

Table 21 Package characteristics

Parameter	Description	Min	Typ	Max	Unit
T _A	Operating ambient temperature (Industrial)	-40	25	85	°C
T _A	Operating ambient temperature (Automotive)	-40	25	105	°C
T _{HJ}	Package θ _{JA}	-	18.4	-	°C/W

Table 22 Solder reflow peak temperature

Package	Maximum peak temperature	Maximum time at peak temperature
24-lead QFN	260°C	30 s

Table 23 Package moisture sensitivity level (MSL), IPC/JEDEC J-STD-2

Package	MSL
24-lead QFN	MSL 3

10 Acronyms

Table 24 Acronyms used in this document

Acronym	Description
BCD	battery charger detection
CDC	communication driver class
CDP	charging downstream port
DCP	dedicated charging port
DLL	dynamic link library
ESD	electrostatic discharge
GPIO	general purpose input/output
HBM	human-body model
I ² C	inter-integrated circuit
MCU	microcontroller unit
OSC	oscillator
PHDC	personal health care device class
PID	product identification
SCB	serial communication block
SCL	I ² C serial clock
SDA	I ² C serial data
SDP	standard downstream port
SIE	serial interface engine
SPI	serial peripheral interface
VCOM	virtual communication port
USB	Universal Serial Bus
UART	universal asynchronous receiver transmitter
VID	vendor identification

More information

11 More information

Infineon provides a wealth of data at www.infineon.com to help you to select the right device for your design, and to help you to quickly and effectively integrate the device into your design. For a comprehensive list of resources, see the product brief: [EZ-USB™ serial bridge controller](#).

- Overview: [USB portfolio](#), [Product selection guide](#)
- USB 2.0 product selectors: [USB 2.0 Peripheral Controllers](#), [EZ-USB™ serial bridge controller](#)
- Knowledge base articles: Infineon offers a large number of USB knowledge base articles covering a broad range of topics, from basic to advanced level. Recommended knowledge base articles for getting started with USB-Serial Bridge Controller are:
 - [KBA85909](#) – Key features of the Infineon USB-Serial Bridge Controller
 - [KBA85920](#) – USB-UART and USB-Serial
 - [KBA85921](#) – Replacing FT232R with CY7C65213 USB-UART LP Bridge Controller
 - [KBA85913](#) – Voltage supply range for USB-Serial
 - [KBA89355](#) – USB Serial Infineon Default VID and PID
 - [KBA92641](#) – USB-Serial Bridge Controller Managing I/Os using API
 - [KBA92442](#) – Non-Standard Baud Rates in USB-Serial Bridge Controllers
 - [KBA91366](#) – Binding a USB-Serial Device to a Microsoft® CDC Driver
 - [KBA92551](#) – Testing a USB-Serial Bridge Controller Configured as USB-UART with Linux®
 - [KBA91299](#) – Interfacing an External I2C Device with the CYUSBS234/236 DVK

For complete list of knowledge base articles, click [here](#).

- Code examples: [USB Full-Speed](#)
- Development kits:
 - [CYUSBS232](#), Infineon USB-UART LP Reference Design Kit
 - [CYUSBS234](#), Infineon USB-Serial (Single Channel) Development Kit
 - [CYUSBS236](#), Infineon USB-Serial (Dual Channel) Development Kit
- Models: [IBIS](#)
Infineon USB-Serial (Single Channel) Development Kit

12 Document conventions

12.1 Units of measure

Table 25 Units of measure

Symbol	Unit of measure
°C	degree celsius
DMIPS	Dhrystone million instructions per second
kΩ	kilo-ohm
KB	kilobyte
kHz	kilohertz
kV	kilovolt
Mbps	megabits per second
MHz	megahertz
mm	millimeter
V	volt

13 Errata

This section describes the errata for the CY7C65211/CY7C65211A USB-Serial family. Details include errata trigger conditions, scope of impact, and available workaround.

Contact your local Infineon Sales Representative if you have questions.

Part numbers affected

Part number	Device characteristics
CY7C65211	All variants
CY7C65211A	All variants

Qualification status

Production

Errata summary

The following table defines the errata applicability to available USB-Serial devices.

Items	Affected part numbers	Fix status
[1] The measured I²C Master clock (SCL) frequency is different from the configured clock frequency	CY7C65211	Fixed in CY7C65211A
[2] Data loss during SPI communication at data rate of 3 Mbps	CY7C65211	Fixed in CY7C65211A
[3] USB-Serial as I²C Master reads one extra byte of data than requested by the USB host	CY7C65211	Fixed in CY7C65211A
[4] I²C Reads are slower when USB-Serial is configured as I²C master	CY7C65211 CY7C65211A	No fix
[5] USB-Serial does not report UART frame errors	CY7C65211 CY7C65211A	No fix
[6] USB-Serial does not report MARK or SPACE parity errors	CY7C65211 CY7C65211A	No fix

1. The measured I²C Master clock (SCL) frequency is different from the configured clock frequency

Problem definition	The measured I ² C clock frequency is 20 percent less than the configured SCL frequency.
Parameters affected	NA
Trigger condition(s)	NA
Scope of impact	I ² C read and write operations will be slower than the configured rate.
Workaround	No workaround
Fix status	Fixed in CY7C65211A

2. Data loss during SPI communication at data rate of 3 Mbps	
Problem definition	Data loss is observed when using SPI at data rate of 3 Mbps
Parameters affected	NA
Trigger condition(s)	Data rate of 3 Mbps triggers the data loss during SPI communication
Scope of impact	Data loss will be observed at 3 Mbps during SPI communication
Workaround	No workaround
Fix status	Fixed in CY7C65211A

3. USB-Serial as I²C Master reads one extra byte of data than requested by the USB host	
Problem definition	USB-Serial configured as an I ² C Master reads an extra byte of data than requested from an I ² C Slave. However, only the requested number of bytes are returned to the USB host.
Parameters affected	NA
Trigger condition(s)	No specific trigger condition. An extra byte of data is read from the slave by the master on every I ² C read.
Scope of impact	I ² C slave may enter an unrecoverable state and hold the SCL line indefinitely, eventually resulting in data loss.
Workaround	No workaround
Fix status	Fixed in CY7C65211A

4. I²C Reads are slower when USB-Serial is configured as I²C master	
Problem definition	I ² C reads done by USB-Serial configured as I ² C master are observed to be slower. This is because of significant delay between the I ² C read initiation and the reception of data from the I ² C Slave.

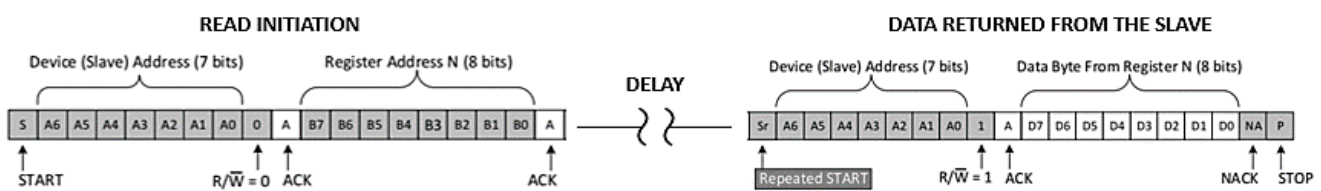

Parameters affected	NA
Trigger condition(s)	No specific trigger condition. The delay is observed between every I ² C Read initiation from the master and reception of slave data.
Scope of impact	I ² C read operations from the master are slower
Workaround	KBA227320 mentions the steps needed to be taken for reducing this delay
Fix status	No fix. Workaround is proven.

5. USB-Serial does not report UART frame errors

Problem definition	USB-Serial does not report UART frame errors while receiving UART data when the number of stop bits is set as '1'
Parameters affected	NA
Trigger condition(s)	USB-Serial fails to report a UART Frame error when the number of stop bits is set as '1'. It correctly reports the error when the stop bits is not '1'.
Scope of impact	No impact
Workaround	No workaround. In general, applications using UART will have to include checksum or CRC in the data to ensure frame integrity.
Fix status	No fix

6. USB-Serial does not report MARK or SPACE parity errors

Problem definition	USB-Serial does not report UART parity error while receiving the data when configured for MARK or SPACE parity.
Parameters affected	NA
Trigger condition(s)	USB Serial fails to report UART parity errors while receiving data when configured for MARK or SPACE parity. Note that USB-Serial detects parity errors when configured for ODD or EVEN parity settings.
Scope of impact	No impact
Workaround	No workaround. In general, applications using UART will have to include checksum or CRC in the data to ensure frame integrity.
Fix status	No fix

Revision history

Document revision	Date	Description of changes
*F	2014-02-21	Updated Ordering information : Updated part numbers.
*G	2015-01-19	Added More information . Updated to new template.
*H	2015-06-23	Updated Features : Updated description. Updated Functional overview : Updated Serial communication : Updated UART interface : Updated description. Updated I2C interface : Updated description. Updated System resources : Updated Power system : Updated description. Updated Internal 32-kHz oscillator : Updated description. Updated Reset : Updated description. Updated Software : Updated Drivers for Windows operating systems : Updated description. Updated Windows-CE support : Updated description. Updated Electrical specifications : Updated Operating conditions : Updated details corresponding to V _{BUS} supply voltage. Updated Device-level specifications : Updated Table 5 : Changed maximum value of V _{BUS} parameter from 5.25 V to 5.5 V. Updated Table 6 : Removed F1 parameter and its details. Removed F2 parameter and its details. Updated Pin description : Updated details in “Description” column of pin 15. Updated USB power configurations : Updated Self-powered configuration : Updated Figure 4 . Updated Application examples : Updated USB to SPI Bridge : Updated description. Updated Package information : spec 001-13937 – Changed revision from *E to *F. Updated to new template. Completing Sunset Review.

Revision history

Document revision	Date	Description of changes
*I	2015-12-24	<p>Updated Document Title to read as “CY7C65211/CY7C65211A, USB-Serial single-channel (UART/I²C/SPI) bridge with CAPSENSE™ and BCD”.</p> <p>Included details of CY7C65211A part number in all instances across the document.</p> <p>Updated Features: Updated description. Added CY7C65211 and CY7C65211A features comparison.</p> <p>Updated More information: Updated description.</p> <p>Updated Functional overview: Updated Serial communication: Updated UART interface: Updated description.</p> <p>Updated UART flow control: Updated description.</p> <p>Updated SPI interface: Updated description.</p> <p>Updated Internal flash configuration: Updated Table 2: Updated details in “Default Value” column corresponding to USB Product ID (PID) parameter.</p> <p>Updated Electrical specifications: Updated Operating conditions: Updated details corresponding to “V_{BUS} supply voltage”.</p> <p>Updated Device-level specifications: Updated Table 5: Changed maximum value of V_{BUS} parameter from 5.5 V to 5.25 V.</p> <p>Updated details in “Details/Conditions” column corresponding to I_{DD2} parameter.</p> <p>Updated Pin description: Updated details in “Description” column corresponding to V_{BUS} pin.</p> <p>Updated USB power configurations: Updated USB bus-powered configuration: Updated Figure 3. Updated Self-powered configuration: Updated Figure 4. Updated USB bus-powered with variable I/O voltage: Updated Figure 5.</p> <p>Updated Application examples: Updated USB to RS232 bridge: Updated Figure 6. Added USB to RS485 Bridge. Updated Battery-operated, bus-powered USB to MCU with battery charge detection: Updated Figure 9. Updated Figure 10.</p> <p>Updated CAPSENSE™: Updated Figure 13. Updated USB to I²C bridge: Updated Figure 14. Updated USB to SPI Bridge: Updated Figure 15.</p> <p>Updated Ordering information: Updated part numbers. Updated Ordering code definitions.</p>
*J	2017-05-03	Updated Cypress Logo and Copyright.

Revision history

Document revision	Date	Description of changes
*K	2018-03-21	Updated Ordering information : No change in part numbers. Replaced “Tube” with “Tray” in Ordering code definitions .
*L	2019-06-11	Added Errata . Updated to new template.
*M	2024-03-27	Added Automotive temperature range related information in all instances across the document. Updated Features : Updated description. Updated Applications : Updated description. Updated More information : Updated description. Updated hyperlinks. Updated Functional overview : Updated CAPSENSE™ : Updated description. Updated Software : Updated Drivers for Windows operating systems : Updated hyperlinks. Updated Internal flash configuration : Updated hyperlinks. Updated Ordering information : Updated part numbers. Updated Ordering code definitions . Migrated to Infineon template.

Trademarks

All referenced product or service names and trademarks are the property of their respective owners.

Edition 2024-03-27

Published by

**Infineon Technologies AG
81726 Munich, Germany**

**© 2024 Infineon Technologies AG.
All Rights Reserved.**

Do you have a question about this document?

Email:

erratum@infineon.com

Document reference

001-82042 Rev. *M

IMPORTANT NOTICE

The information given in this document shall in no event be regarded as a guarantee of conditions or characteristics ("Beschaffenheitsgarantie").

With respect to any examples, hints or any typical values stated herein and/or any information regarding the application of the product, Infineon Technologies hereby disclaims any and all warranties and liabilities of any kind, including without limitation warranties of non-infringement of intellectual property rights of any third party.

In addition, any information given in this document is subject to customer's compliance with its obligations stated in this document and any applicable legal requirements, norms and standards concerning customer's products and any use of the product of Infineon Technologies in customer's applications.

The data contained in this document is exclusively intended for technically trained staff. It is the responsibility of customer's technical departments to evaluate the suitability of the product for the intended application and the completeness of the product information given in this document with respect to such application.



WARNINGS

Due to technical requirements products may contain dangerous substances. For information on the types in question please contact your nearest Infineon Technologies office.

Except as otherwise explicitly approved by Infineon Technologies in a written document signed by authorized representatives of Infineon Technologies, Infineon Technologies' products may not be used in any applications where a failure of the product or any consequences of the use thereof can reasonably be expected to result in personal injury.

Looking for pricing, stock, or lifecycle information?

Click below to explore more details on WIN SOURCE:

-  [View CY7C65211A-24LTXI on WIN SOURCE](#)
-  [Infineon Technologies Information](#)

Optimize Your Supply Chain with WIN SOURCE Solutions

-  Global Sourcing Solution
-  Obsolete Management
-  Cost Control Management
-  Shortage Management
-  Alternative Solution
-  Excess Inventory Management