



# THE DATASHEET OF DRV8301DCAR



# DRV8301 Three-Phase Gate Driver With Dual Current Shunt Amplifiers and Buck Regulator

## 1 Features

- 6-V to 60-V Operating Supply Voltage Range
- 1.7-A Source and 2.3-A Sink Gate Drive Current Capability
- Slew Rate Control for EMI Reduction
- Bootstrap Gate Driver With 100% Duty Cycle Support
- 6- or 3-PWM Input Modes
- Dual Integrated Current Shunt Amplifiers With Adjustable Gain and Offset
- Integrated 1.5-A Buck Converter
- 3.3-V and 5-V Interface Support
- SPI
- Protection Features:
  - Programmable Dead Time Control (DTC)
  - Programmable Overcurrent Protection (OCP)
  - PVDD and GVDD Undervoltage Lockout (UVLO)
  - GVDD Overvoltage Lockout (OVLO)
  - Overtemperature Warning/Shutdown (OTW/OTS)
  - Reported Through nFAULT, nOCTW, and SPI Registers

## 2 Applications

- 3-Phase BLDC and PMSM Motors
- CPAPs and Pumps
- E-bikes
- Power Tools
- Robotics and RC Toys
- Industrial Automation

## 3 Description

The DRV8301 is a gate driver IC for three-phase motor drive applications. The device provides three half-bridge drivers, each capable of driving two N-channel MOSFETs. The DRV8301 supports up to 1.7-A source and 2.3-A peak current capability. The DRV8301 can operate off of a single power supply with a wide range from 6-V to 60-V. The device uses a bootstrap gate driver architecture with trickle charge circuitry to support 100% duty cycle. The DRV8301 uses automatic handshaking when the high-side or low-side MOSFET is switching to prevent flow of current. Integrated VDS sensing of the high-side and low-side MOSFETs is used to protect the external power stage against overcurrent conditions.

The DRV8301 includes two current shunt amplifiers for accurate current measurement. The amplifiers support bidirectional current sensing and provide an adjustable output offset up to 3 V.

The DRV8301 also includes an integrated switching mode buck converter with adjustable output and switching frequency. The buck converter can provide up to 1.5 A to support MCU or additional system power needs.

The SPI provides detailed fault reporting and flexible parameter settings such as gain options for the current shunt amplifiers and slew rate control of the gate drivers.

### Device Information<sup>(1)</sup>

PART NUMBER	PACKAGE	BODY SIZE (NOM)
DRV8301	HTSSOP (56)	14.00 mm x 8.10 mm

(1) For all available packages, see the orderable addendum at the end of the data sheet.

### Simplified Schematic

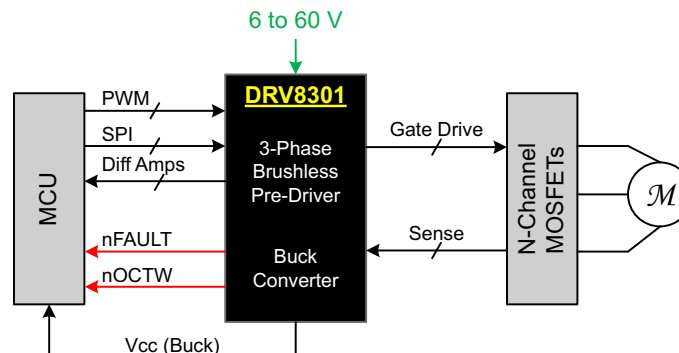

## Table of Contents

<b>1 Features</b> .....	1	7.3 Feature Description.....	15
<b>2 Applications</b> .....	1	7.4 Device Functional Modes .....	20
<b>3 Description</b> .....	1	7.5 Programming.....	21
<b>4 Revision History</b> .....	2	7.6 Register Maps .....	22
<b>5 Pin Configuration and Functions</b> .....	3	<b>8 Application and Implementation</b> .....	24
<b>6 Specifications</b> .....	6	8.1 Application Information.....	24
6.1 Absolute Maximum Ratings .....	6	8.2 Typical Application .....	25
6.2 ESD Ratings.....	6	<b>9 Power Supply Recommendations</b> .....	28
6.3 Recommended Operating Conditions.....	7	9.1 Bulk Capacitance .....	28
6.4 Thermal Information .....	7	<b>10 Layout</b> .....	29
6.5 Electrical Characteristics.....	8	10.1 Layout Guidelines .....	29
6.6 Current Shunt Amplifier Characteristics.....	9	10.2 Layout Example .....	30
6.7 Buck Converter Characteristics .....	10	<b>11 Device and Documentation Support</b> .....	31
6.8 SPI Timing Requirements (Slave Mode Only) .....	10	11.1 Documentation Support .....	31
6.9 Gate Timing and Protection Switching Characteristics .....	11	11.2 Community Resources.....	31
6.10 Typical Characteristics .....	12	11.3 Trademarks .....	31
<b>7 Detailed Description</b> .....	13	11.4 Electrostatic Discharge Caution.....	31
7.1 Overview .....	13	11.5 Glossary .....	31
7.2 Functional Block Diagram .....	14	<b>12 Mechanical, Packaging, and Orderable Information</b> .....	31

## 4 Revision History

NOTE: Page numbers for previous revisions may differ from page numbers in the current version.

Changes from Revision E (October 2015) to Revision F	Page
<ul style="list-style-type: none"> <li>Changed <math>V_{EN\_BUCK}</math> in <a href="#">Buck Converter Characteristics</a> From: MIN = 0.9 V and MAX = 1.55 V To: MIN = 1.11 V and MAX = 1.36 V. ....</li> </ul>	10

Changes from Revision D (August 2015) to Revision E	Page
<ul style="list-style-type: none"> <li>Corrected table note for dead time programming definition .....</li> <li>Updated description of gate driver power-up sequencing errata .....</li> <li>Fixed connections for pin 25 in <a href="#">Figure 7</a> .....</li> </ul>	11 24 25

Changes from Revision C (January 2015) to Revision D	Page
<ul style="list-style-type: none"> <li><math>V_{PVD}</math> absolute max voltage rating reduced from 70 V to 65 V .....</li> <li>Clarification made on how the OCP status bits report in <a href="#">Overcurrent Protection and Reporting (OCP)</a> .....</li> <li>Update to PVDD1 undervoltage protection in <a href="#">Undervoltage Protection (PVDD_UV and GVDD_UV)</a> describing specific transient brownout issue. ....</li> <li>Update to EN_GATE pin functional description in <a href="#">EN_GATE</a> clarifying proper EN_GATE reset pulse lengths. ....</li> <li>Added gate driver power-up sequencing errata .....</li> <li>Added <a href="#">Community Resources</a> .....</li> </ul>	6 17 18 20 24 31

Changes from Revision B (August 2013) to Revision C	Page
<ul style="list-style-type: none"> <li>Added <a href="#">ESD Ratings</a> table, <a href="#">Feature Description</a> section, <a href="#">Device Functional Modes</a>, <a href="#">Application and Implementation</a> section, <a href="#">Power Supply Recommendations</a> section, <a href="#">Layout</a> section, <a href="#">Device and Documentation Support</a> section, and <a href="#">Mechanical, Packaging, and Orderable Information</a> section .....</li> </ul>	6

## 5 Pin Configuration and Functions

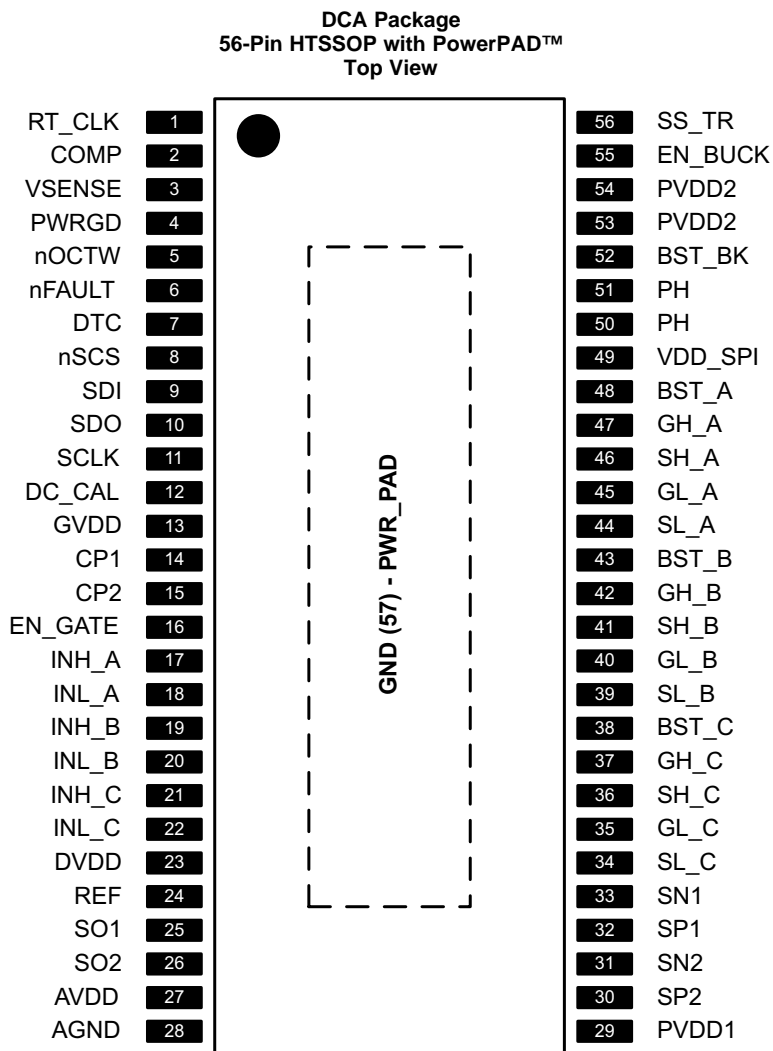

### Pin Functions

PIN		TYPE <sup>(1)</sup>	DESCRIPTION
NAME	NO.		
RT_CLK	1	I	Resistor timing and external clock for buck regulator. Resistor should connect to GND (PowerPAD™) with very short trace to reduce the potential clock jitter due to noise.
COMP	2	O	Buck error amplifier output and input to the output switch current comparator.
VSENSE	3	I	Buck output voltage sense pin. Inverting node of error amplifier.
PWRGD	4	O	An open-drain output with external pullup resistor required. Asserts low if buck output voltage is low due to thermal shutdown, dropout, overvoltage, or EN_BUCK shut down
nOCTW	5	O	Overcurrent and/or overtemperature warning indicator. This output is open drain with external pullup resistor required. Programmable output mode via SPI registers.
nFAULT	6	O	Fault report indicator. This output is open drain with external pullup resistor required.
DTC	7	I	Dead-time adjustment with external resistor to GND
nSCS	8	I	SPI chip select
SDI	9	I	SPI input
SDO	10	O	SPI output

(1) KEY: I = Input, O = Output, P = Power

**Pin Functions (continued)**

PIN		TYPE <sup>(1)</sup>	DESCRIPTION
NAME	NO.		
SCLK	11	I	SPI clock signal
DC_CAL	12	I	When DC_CAL is high, device shorts inputs of shunt amplifiers and disconnects loads. DC offset calibration can be done through external microcontroller.
GVDD	13	P	Internal gate driver voltage regulator. GVDD cap should connect to GND
CP1	14	P	Charge pump pin 1, ceramic capacitor should be used between CP1 and CP2
CP2	15	P	Charge pump pin 2, ceramic capacitor should be used between CP1 and CP2
EN_GATE	16	I	Enable gate driver and current shunt amplifiers. Control buck through EN_BUCK pin.
INH_A	17	I	PWM input signal (high side), half-bridge A
INL_A	18	I	PWM input signal (low side), half-bridge A
INH_B	19	I	PWM input signal (high side), half-bridge B
INL_B	20	I	PWM input signal (low side), half-bridge B
INH_C	21	I	PWM input signal (high side), half-bridge C
INL_C	22	I	PWM input signal (low side), half-bridge C
DVDD	23	P	Internal 3.3-V supply voltage. DVDD cap should connect to AGND. This is an output, but not specified to drive external circuitry.
REF	24	I	Reference voltage to set output of shunt amplifiers with a bias voltage which equals to half of the voltage set on this pin. Connect to ADC reference in microcontroller.
SO1	25	O	Output of current amplifier 1
SO2	26	O	Output of current amplifier 2
AVDD	27	P	Internal 6-V supply voltage, AVDD cap should always be installed and connected to AGND. This is an output, but not specified to drive external circuitry.
AGND	28	P	Analog ground pin. Connect directly to GND (PowerPAD).
PVDD1	29	P	Power supply pin for gate driver, current shunt amplifier, and SPI communication. PVDD1 is independent of buck power supply, PVDD2. PVDD1 cap should connect to GND
SP2	30	I	Input of current amplifier 2 (connecting to positive input of amplifier). Recommend to connect to ground side of the sense resistor for the best common mode rejection.
SN2	31	I	Input of current amplifier 2 (connecting to negative input of amplifier).
SP1	32	I	Input of current amplifier 1 (connecting to positive input of amplifier). Recommend to connect to ground side of the sense resistor for the best common mode rejection.
SN1	33	I	Input of current amplifier 1 (connecting to negative input of amplifier).
SL_C	34	I	Low-Side MOSFET source connection, half-bridge C. Low-side $V_{DS}$ measured between this pin and SH_C.
GL_C	35	O	Gate drive output for low-side MOSFET, half-bridge C
SH_C	36	I	High-side MOSFET source connection, half-bridge C. High-side $V_{DS}$ measured between this pin and PVDD1.
GH_C	37	O	Gate drive output for high-side MOSFET, half-bridge C
BST_C	38	P	Bootstrap cap pin for half-bridge C
SL_B	39	I	Low-side MOSFET source connection, half-bridge B. Low-side $V_{DS}$ measured between this pin and SH_B.
GL_B	40	O	Gate drive output for low-side MOSFET, half-bridge B
SH_B	41	I	High-side MOSFET source connection, half-bridge B. High-side $V_{DS}$ measured between this pin and PVDD1.
GH_B	42	O	Gate drive output for high-side MOSFET, half-bridge B
BST_B	43	P	Bootstrap cap pin for half-bridge B
SL_A	44	I	Low-side MOSFET source connection, half-bridge A. Low-side $V_{DS}$ measured between this pin and SH_A.
GL_A	45	O	Gate drive output for low-side MOSFET, half-bridge A
SH_A	46	I	High-side MOSFET source connection, half-bridge A. High-side $V_{DS}$ measured between this pin and PVDD1.
GH_A	47	O	Gate drive output for high-side MOSFET, half-bridge A

**Pin Functions (continued)**

PIN		TYPE <sup>(1)</sup>	DESCRIPTION
NAME	NO.		
BST_A	48	P	Bootstrap cap pin for half-bridge A
VDD_SPI	49	I	SPI supply pin to support 3.3-V or 5-V logic. Connect to the same supply that the MCU uses for SPI operation.
PH	50, 51	O	The source of the internal high side MOSFET of buck converter
BST_BK	52	P	Bootstrap cap pin for buck converter
PVDD2	53, 54	P	Power supply pin for buck converter, PVDD2 cap should connect to GND.
EN_BUCK	55	I	Enable buck converter. Internal pullup current source. Pull below 1.2 V to disable. Float to enable. Adjust the input undervoltage lockout with two resistors
SS_TR	56	I	Buck soft-start and tracking. An external capacitor connected to this pin sets the output rise time. Because the voltage on this pin overrides the internal reference, it can be used for tracking and sequencing. Cap should connect to GND
GND (PowerPAD)	57	P	GND pin. The exposed power pad must be electrically connected to ground plane through soldering to PCB for proper operation and connected to bottom side of PCB through vias for better thermal spreading.

## 6 Specifications

### 6.1 Absolute Maximum Ratings

 see <sup>(1)</sup>

			MIN	MAX	UNIT
V <sub>PVDD</sub>	Supply voltage	Relative to PGND	-0.3	65	V
	Maximum supply voltage ramp rate	Voltage rising up to PVDD <sub>MAX</sub>		1	V/μS
V <sub>PGND</sub>	Maximum voltage between PGND and GND		-0.3	0.3	V
I <sub>IN_MAX</sub>	Maximum current for all digital and analog inputs (INH_A, INL_A, INH_B, INL_B, INH_C, INL_C, SCLK, SCS, SDI, EN_GATE, DC_CAL, DTC)		-1	1	mA
I <sub>SINK_MAX</sub>	Maximum sinking current for open-drain pins (nFAULT and nOCTW Pins)			7	mA
V <sub>OPA_IN</sub>	Voltage for SPx and SNx pins		-0.6	0.6	V
V <sub>LOGIC</sub>	Input voltage range for logic/digital pins (INH_A, INL_A, INH_B, INL_B, INH_C, INL_C, EN_GATE, SCLK, SDI, SCS, DC_CAL)		-0.3	7	V
V <sub>GVDD</sub>	Maximum voltage for GVDD pin			13.2	V
V <sub>AVDD</sub>	Maximum voltage for AVDD pin			8	V
V <sub>DVDD</sub>	Maximum voltage for DVDD pin			3.6	V
V <sub>VDD_SPI</sub>	Maximum voltage for VDD_SPI pin			7	V
V <sub>SDO</sub>	Maximum voltage for SDO pin			VDD_SPI + 0.3	V
V <sub>REF</sub>	Maximum reference voltage for current amplifier			7	V
I <sub>REF</sub>	Maximum current for REF pin			100	μA
T <sub>J</sub>	Maximum operating junction temperature		-40	150	°C
T <sub>stg</sub>	Storage temperature		-55	150	°C

(1) Stresses beyond those listed under *Absolute Maximum Ratings* may cause permanent damage to the device. These are stress ratings only, and functional operation of the device at these or any other conditions beyond those indicated under *Recommended Operating Conditions* is not implied. Exposure to absolute-maximum-rated conditions for extended periods may affect device reliability.

### 6.2 ESD Ratings

			VALUE	UNIT
V <sub>(ESD)</sub>	Electrostatic discharge	Human body model (HBM), per ANSI/ESDA/JEDEC JS-001, all pins <sup>(1)</sup>	±2000	V
		Charged device model (CDM), per JEDEC specification JESD22-C101, all pins <sup>(2)</sup>	±500	

(1) JEDEC document JEP155 states that 500-V HBM allows safe manufacturing with a standard ESD control process.

(2) JEDEC document JEP157 states that 250-V CDM allows safe manufacturing with a standard ESD control process.

### 6.3 Recommended Operating Conditions

			MIN	MAX	UNIT
V <sub>PVDD1</sub>	DC supply voltage PVDD1 for normal operation	Relative to PGND	6	60	V
V <sub>PVDD2</sub>	DC supply voltage PVDD2 for buck converter		3.5	60	V
I <sub>DIN_EN</sub>	Input current of digital pins when EN_GATE is high			100	μA
I <sub>DIN_DIS</sub>	Input current of digital pins when EN_GATE is low			1	μA
C <sub>O_OPA</sub>	Maximum output capacitance on outputs of shunt amplifier			20	pF
R <sub>DTC</sub>	Dead time control resistor range. Time range is 50 ns (-GND) to 500 ns (150 kΩ) with a linear approximation.		0	150	kΩ
I <sub>FAULT</sub>	nFAULT pin sink current, open-drain	V = 0.4 V		2	mA
I <sub>OCTW</sub>	nFAULT pin sink current, open-drain	V = 0.4 V		2	mA
V <sub>REF</sub>	External voltage reference voltage for current shunt amplifiers		2	6	V
f <sub>gate</sub>	Operating switching frequency of gate driver	Q <sub>g(TOT)</sub> = 25 nC or total 30-mA gate drive average current		200	kHz
I <sub>gate</sub>	Total average gate drive current			30	mA
T <sub>A</sub>	Ambient temperature		-40	125	°C

### 6.4 Thermal Information

THERMAL METRIC <sup>(1)</sup>		DRV8301	UNIT
		DCA (HTSSOP)	
		56 PINS	
R <sub>θJA</sub>	Junction-to-ambient thermal resistance	30.3	°C/W
R <sub>θJC(top)</sub>	Junction-to-case (top) thermal resistance	33.5	°C/W
R <sub>θJB</sub>	Junction-to-board thermal resistance	17.5	°C/W
ψ <sub>JT</sub>	Junction-to-top characterization parameter	0.9	°C/W
ψ <sub>JB</sub>	Junction-to-board characterization parameter	7.2	°C/W
R <sub>θJC(bot)</sub>	Junction-to-case (bottom) thermal resistance	0.9	°C/W

(1) For more information about traditional and new thermal metrics, see the *Semiconductor and IC Package Thermal Metrics* application report, [SPRA953](#).

## 6.5 Electrical Characteristics

 PVDD = 6 to 60 V, T<sub>C</sub> = 25°C, unless specified under test condition

PARAMETER		TEST CONDITIONS	MIN	TYP	MAX	UNIT
<b>INPUT PINS: INH_X, INL_X, nSCS, SDI, SCLK, EN_GATE, DC_CAL</b>						
V <sub>IH</sub>	High input threshold		2			V
V <sub>IL</sub>	Low input threshold				0.8	V
<b>RPULL_DOWN – INTERNAL PULLDOWN RESISTOR FOR GATE DRIVER INPUTS</b>						
R <sub>EN_GATE</sub>	Internal pulldown resistor for EN_GATE			100		kΩ
R <sub>INH_X</sub>	Internal pulldown resistor for high-side PWMs (INH_A, INH_B, and INH_C)	EN_GATE high		100		kΩ
R <sub>INL_X</sub>	Internal pulldown resistor for low-side PWMs (INL_A, INL_B, and INL_C)	EN_GATE high		100		kΩ
R <sub>nSCS</sub>	Internal pulldown resistor for nSCS	EN_GATE high		100		kΩ
R <sub>SDI</sub>	Internal pulldown resistor for SDI	EN_GATE high		100		kΩ
R <sub>DC_CAL</sub>	Internal pulldown resistor for DC_CAL	EN_GATE high		100		kΩ
R <sub>SCLK</sub>	Internal pulldown resistor for SCLK	EN_GATE high		100		kΩ
<b>OUTPUT PINS: nFAULT AND nOCTW</b>						
V <sub>OL</sub>	Low output threshold	I <sub>O</sub> = 2 mA			0.4	V
V <sub>OH</sub>	High output threshold	External 47 kΩ pullup resistor connected to 3-5.5 V	2.4			V
I <sub>OH</sub>	Leakage Current on Open-Drain Pins When Logic High nFAULT and nOCTW)				1	μA
<b>GATE DRIVE OUTPUT: GH_A, GH_B, GH_C, GL_A, GL_B, GL_C</b>						
V <sub>GX_NORM</sub>	Gate driver V <sub>gs</sub> voltage	PVDD = 8 to 60 V, I <sub>gate</sub> = 30 mA, C <sub>CP</sub> = 22 nF	9.5		11.5	V
		PVDD = 8 to 60 V, I <sub>gate</sub> = 30 mA, C <sub>CP</sub> = 220 nF	9.5		11.5	
V <sub>GX_MIN</sub>	Gate driver V <sub>gs</sub> voltage	PVDD = 6 to 8 V, I <sub>gate</sub> = 15 mA, C <sub>CP</sub> = 22 nF		8.8		V
		PVDD = 6 to 8 V, I <sub>gate</sub> = 30 mA, C <sub>CP</sub> = 220 nF		8.3		
I <sub>oso1</sub>	Maximum source current setting 1, peak	V <sub>gs</sub> of FET equals to 2 V. REG 0x02		1.7		A
I <sub>osi1</sub>	Maximum sink current setting 1, peak	V <sub>gs</sub> of FET equals to 8 V. REG 0x02		2.3		A
I <sub>oso2</sub>	Source current setting 2, peak	V <sub>gs</sub> of FET equals to 2 V. REG 0x02		0.7		A
I <sub>osi2</sub>	Sink current setting 2, peak	V <sub>gs</sub> of FET equals to 8 V. REG 0x02		1		A
I <sub>oso3</sub>	Source current setting 3, peak	V <sub>gs</sub> of FET equals to 2 V. REG 0x02		0.25		A
I <sub>osi3</sub>	Sink current setting 3, peak	V <sub>gs</sub> of FET equals to 8 V. REG 0x02		0.5		A
R <sub>gate_off</sub>	Gate output impedance during standby mode when EN_GATE low (pins GH_x, GL_x)		1.6		2.4	kΩ
<b>SUPPLY CURRENTS</b>						
I <sub>PVDD1_STB</sub>	PVDD1 supply current, standby	EN_GATE is low. PVDD1 = 8 V.		20	50	μA
I <sub>PVDD1_OP</sub>	PVDD1 supply current, operating	EN_GATE is high, no load on gate drive output, switching at 10 kHz, 100 nC gate charge		15		mA
I <sub>PVDD1_HIZ</sub>	PVDD1 Supply current, Hi-Z	EN_GATE is high, gate not switching	2	5	10	mA
<b>INTERNAL REGULATOR VOLTAGE</b>						
A <sub>VDD</sub>	AVDD voltage	PVDD = 8 to 60 V	6	6.5	7	V
		PVDD = 6 to 60 V	5.5		6	
D <sub>VDD</sub>	DVDD voltage		3	3.3	3.6	V
<b>VOLTAGE PROTECTION</b>						
V <sub>PVDD_UV</sub>	Undervoltage protection limit, PVDD	PVDD falling			5.9	V
		PVDD rising			6	
V <sub>GVDD_UV</sub>	Undervoltage protection limit, GVDD	GVDD falling			8	V

## Electrical Characteristics (continued)

PVDD = 6 to 60 V, T<sub>C</sub> = 25°C, unless specified under test condition

PARAMETER		TEST CONDITIONS	MIN	TYP	MAX	UNIT
V <sub>GVDD_OV</sub>	Overvoltage protection limit, GVDD			16		V
<b>CURRENT PROTECTION, (VDS SENSING)</b>						
V <sub>DS_OC</sub>	Drain-source voltage protection limit	PVDD = 8 to 60 V	0.125		2.4	V
		PVDD = 6 to 8 V <sup>(1)</sup>	0.125		1.491	
T <sub>oc</sub>	OC sensing response time			1.5		μs
T <sub>OC_PULSE</sub>	nOCTW pin reporting pulse stretch length for OC event			64		μs
<b>TEMPERATURE PROTECTION</b>						
OTW_CLR	Junction temperature for resetting overtemperature warning			115		°C
OTW_SET/O TSD_CLR	Junction temperature for overtemperature warning and resetting over temperature shut down			130		°C
OTSD_SET	Junction temperature for overtemperature shut down			150		°C

(1) Reduced A<sub>VDD</sub> voltage range results in limitations on settings for overcurrent protection. See [Table 13](#).

## 6.6 Current Shunt Amplifier Characteristics

T<sub>C</sub> = 25°C unless otherwise specified

PARAMETER		TEST CONDITIONS	MIN	TYP	MAX	UNIT
G1	Gain option 1	T <sub>C</sub> = –40°C to 125°C	9.5	10	10.5	V/V
G2	Gain option 2	T <sub>C</sub> = –40°C to 125°C	18	20	21	V/V
G3	Gain Option 3	T <sub>C</sub> = –40°C to 125°C	38	40	42	V/V
G4	Gain Option 4	T <sub>C</sub> = –40°C to 125°C	75	80	85	V/V
t <sub>settling</sub>	Settling time to 1%	T <sub>C</sub> = 0 to 60°C, G = 10, Vstep = 2 V		300		ns
t <sub>settling</sub>	Settling time to 1%	T <sub>C</sub> = 0 to 60°C, G = 20, Vstep = 2 V		600		ns
t <sub>settling</sub>	Settling time to 1%	T <sub>C</sub> = 0 to 60°C, G = 40, Vstep = 2 V		1.2		μs
t <sub>settling</sub>	Settling time to 1%	T <sub>C</sub> = 0 to 60°C, G = 80, Vstep = 2 V		2.4		μs
V <sub>swing</sub>	Output swing linear range		0.3		5.7	V
Slew rate		G = 10		10		V/μs
DC_offset	Offset error RTI	G = 10 with input shorted			4	mV
Drift_offset	Offset drift RTI			10		μV/C
I <sub>bias</sub>	Input bias current				100	μA
V <sub>in_com</sub>	Common input mode range		–0.15		0.15	V
V <sub>in_dif</sub>	Differential input range		–0.3		0.3	V
V <sub>o_bias</sub>	Output bias	With zero input current, Vref up to 6 V	–0.5%	0.5 × Vref	0.5%	V
CMRR_OV	Overall CMRR with gain resistor mismatch	CMRR at DC, gain = 10	70	85		dB

## 6.7 Buck Converter Characteristics

 $T_C = 25^\circ\text{C}$  unless otherwise specified

PARAMETER		TEST CONDITIONS	MIN	TYP	MAX	UNIT
$V_{UVLO}$	Internal undervoltage lockout threshold	No voltage hysteresis, rising and falling		2.5		V
$I_{SD(PVDD2)}$	Shutdown supply current	EN = 0 V, 25°C, 3.5 V ≤ VIN ≤ 60 V		1.3	4	μA
$I_{NON\_SW(PVDD2)}$	Operating: nonswitching supply current	VSENSE = 0.83 V, VIN = 12 V		116	136	μA
$V_{EN\_BUCK}$	Enable threshold voltage	No voltage hysteresis, rising and falling	1.11	1.25	1.36	V
$R_{DS\_ON}$	On-resistance	VIN = 3.5 V, BOOT-PH = 3 V		300		mΩ
$I_{LIM}$	Current limit threshold	VIN = 12 V, T <sub>J</sub> = 25°C	1.8	2.7		A
OTSD_BK	Thermal shutdown			182		°C
$F_{sw}$	Switching frequency	RT = 200 kΩ	450	581	720	kHz
PWRGD	VSENSE threshold	VSENSE falling		92%		
		VSENSE rising		94%		
		VSENSE rising		109%		
		VSENSE falling		107%		
	Hysteresis	VSENSE falling		2%		
	Output high leakage	VSENSE = VREF, V(PWRGD) = 5.5 V, 25°C		10		nA
	On resistance	I(PWRGD) = 3 mA, VSENSE < 0.79 V		50		Ω

## 6.8 SPI Timing Requirements (Slave Mode Only)

PARAMETER		TEST CONDITIONS	MIN	NOM	MAX	UNIT
$t_{SPL\_READY}$	SPI ready after EN_GATE transitions to HIGH	PVDD > 6 V		5	10	ms
$t_{CLK}$	Minimum SPI clock period		100			ns
$t_{CLKH}$	Clock high time	See <a href="#">Figure 1</a>	40			
$t_{CLKL}$	Clock low time	See <a href="#">Figure 1</a>	40			
$t_{SU\_SDI}$	SDI input data setup time		20			ns
$t_{HD\_SDI}$	SDI input data hold time		30			ns
$t_{D\_SDO}$	SDO output data delay time, CLK high to SDO valid	C <sub>L</sub> = 20 pF			20	ns
$t_{HD\_SDO}$	SDO output data hold time	See <a href="#">Figure 1</a>	40			
$t_{SU\_SCS}$	SCS setup time	See <a href="#">Figure 1</a>	50			ns
$t_{HD\_SCS}$	SCS hold time		50			ns
$t_{HL\_SCS}$	SCS minimum high time before SCS active low		40			ns
$t_{ACC}$	SCS access time, SCS low to SDO out of high impedance			10		ns
$t_{DIS}$	SCS disable time, SCS high to SDO high impedance			10		ns

## 6.9 Gate Timing and Protection Switching Characteristics

over operating free-air temperature range (unless otherwise noted)

PARAMETER	TEST CONDITIONS	MIN	TYP	MAX	UNIT
<b>TIMING, OUTPUT PINS</b>					
$t_{pd,lf-O}$	Positive input falling to GH_x falling		45		ns
$t_{pd,lr-O}$	Positive input rising to GL_x falling		45		ns
$t_{d\_min}$	Minimum dead time after hand shaking <sup>(1)</sup>			50	ns
$t_{dtp}$	Dead time	With R <sub>DTC</sub> set to different values	50	500	ns
$t_{GDr}$	Rise time, gate drive output	CL = 1 nF, 10% to 90%	25		ns
$t_{GDF}$	Fall time, gate drive output	CL = 1 nF, 90% to 10%	25		ns
$t_{ON\_MIN}$	Minimum on pulse	Not including handshake communication. Hi-Z to on state, output of gate driver		50	ns
$t_{pd\_match}$	Propagation delay matching between high side and low side			5	ns
$t_{dt\_match}$	Deadtime matching			5	ns
<b>TIMING, PROTECTION, AND CONTROL</b>					
$t_{pd,R\_GATE-OP}$	Start-up time, from EN_GATE active high to device ready for normal operation	PVDD is up before start-up, all charge pump caps and regulator caps as in recommended condition	5	10	ms
$t_{pd,R\_GATE-Quick}$	If EN_GATE goes from high to low and back to high state within quick reset time, it will only reset all faults and gate driver without powering down charge pump, current amp, and related internal voltage regulators.	Maximum low pulse time		10	μs
$t_{pd,E-L}$	Delay, error event to all gates low		200		ns
$t_{pd,E-FAULT}$	Delay, error event to nFAULT low		200		ns

(1) Dead time programming definition: Adjustable delay from GH\_X falling edge to GL\_X rising edge, and GL\_X falling edge to GH\_X rising edge. In 6-PWM input mode, this adjustable value is added to the timing delay between inputs as set by the microcontroller externally.

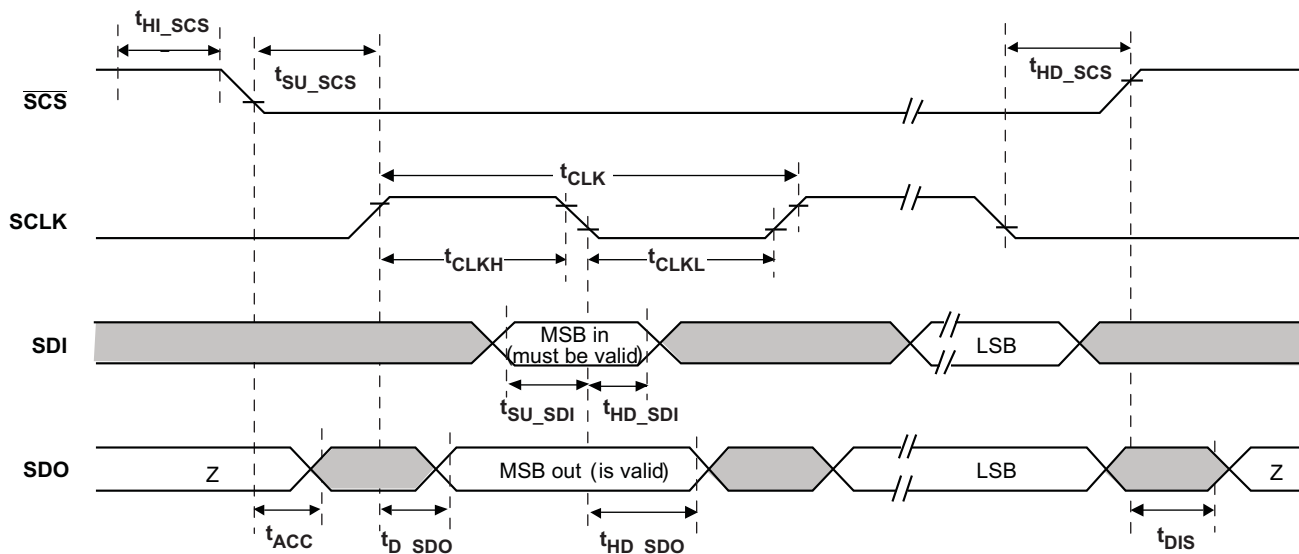

Figure 1. SPI Slave Mode Timing Definition

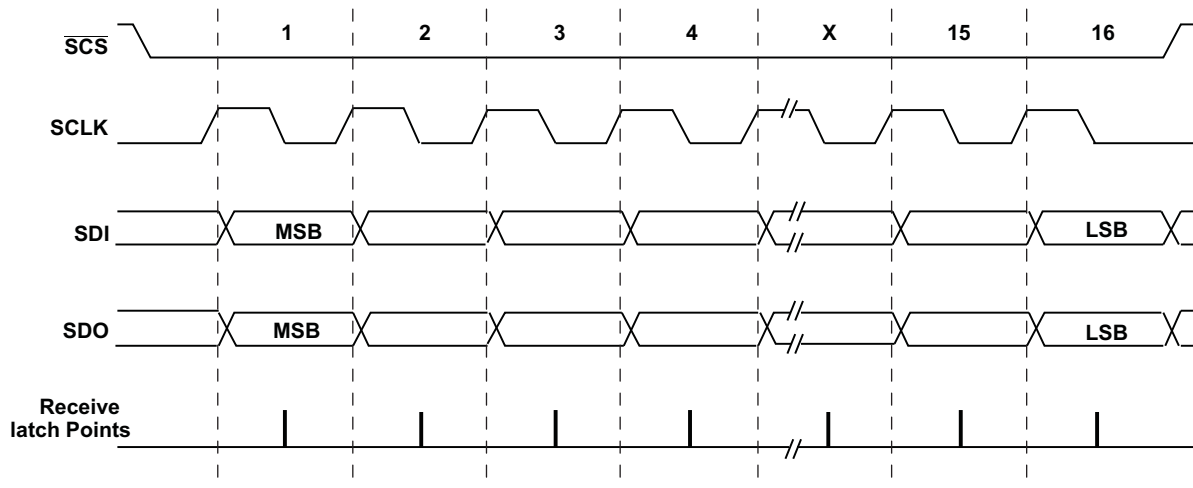

Figure 2. SPI Slave Mode Timing Diagram

### 6.10 Typical Characteristics

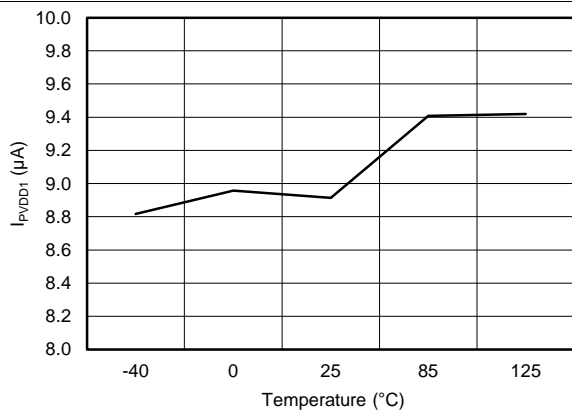

Figure 3. I<sub>PVDD1</sub> vs Temperature (PVDD1 = 8 V, EN\_GATE = LOW)

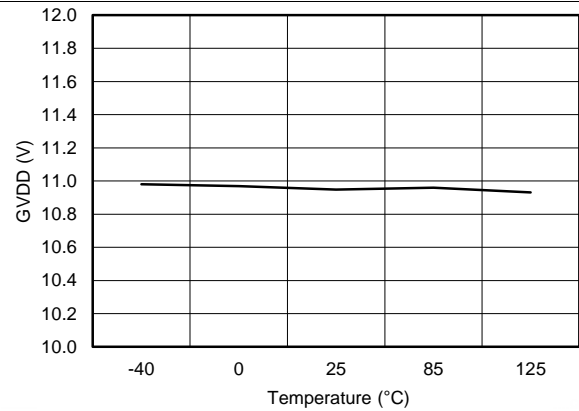

Figure 4. GVDD vs Temperature (PVDD1 = 8 V, EN\_GATE = HIGH)

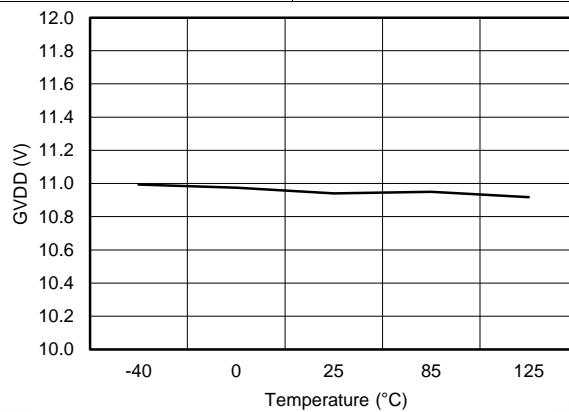

Figure 5. GVDD vs Temperature (PVDD1 = 60 V, EN\_GATE = HIGH)

## 7 Detailed Description

### 7.1 Overview

The DRV8301 is a 6-V to 60-V gate driver IC for three-phase motor drive applications. This device reduces external component count by integrating three half-bridge drivers, two current shunt amplifiers, and a switching buck converter. The DRV8301 provides overcurrent, overtemperature, and undervoltage protection. Fault conditions are indicated through the nFAULT and nOCTW pins in addition to the SPI registers.

Adjustable dead time control and peak gate drive current allows for finely tuning the switching of the external MOSFETs. Internal hand-shaking is used to prevent flow of current.

VDS sensing of the external MOSFETs allows for the DRV8301 to detect overcurrent conditions and respond appropriately. Individual MOSFET overcurrent conditions are reported through the SPI status registers.

The highly configurable buck converter can support a wide range of output options. This allows the DRV8301 to provide a power supply rail for the controller and lower voltage components.

## 7.2 Functional Block Diagram

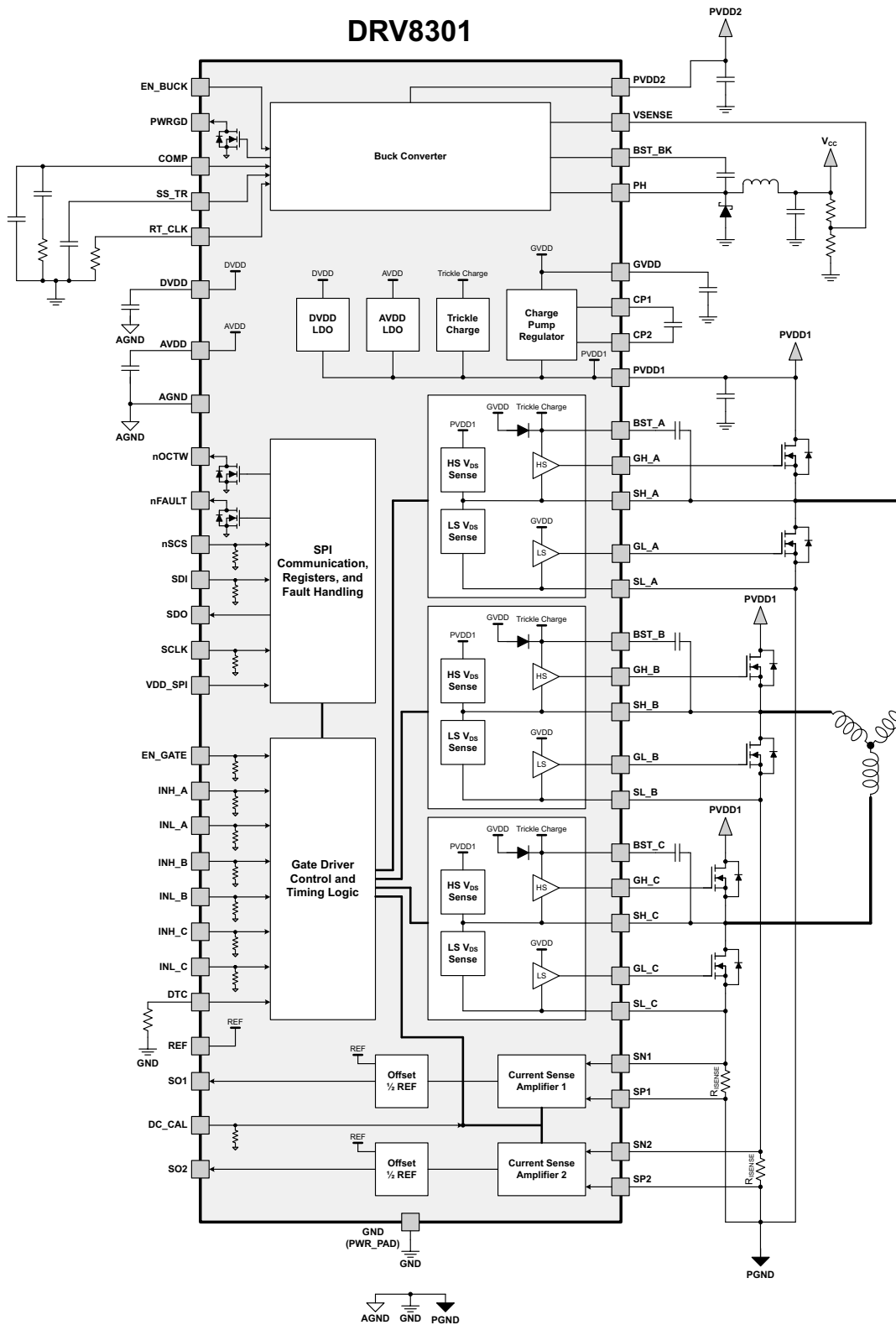

## 7.3 Feature Description

### 7.3.1 Three-Phase Gate Driver

The half-bridge drivers use a bootstrap configuration with a trickle charge pump to support 100% duty cycle operation. Each half-bridge is configured to drive two N-channel MOSFETs, one for the high-side and one for the low-side. The half-bridge drivers can be used in combination to drive a 3-phase motor or separately to drive various other loads.

The peak gate drive current and internal dead times are adjustable to accommodate a variety of external MOSFETs and applications. The peak gate drive current is set through a register setting and the dead time is adjusted with an external resistor on the DTC pin. Shorting the DTC pin to ground will provide the minimum dead time (50ns). There is an internal hand shake between the high side and low side MOSFETs during switching transitions to prevent current shoot through.

The three-phase gate driver can provide up to 30mA of average gate drive current. This will support switching frequencies up to 200 kHz when the MOSFET  $Q_g = 25\text{nC}$ .

Each MOSFET gate driver has a VDS sensing circuit for overcurrent protection. The sense circuit measures the voltage from the drain to the source of the external MOSFETs while the MOSFET is enabled. This voltage is compared against the programmed trip point to determine if an overcurrent event has occurred. The high-side sense is between the PVDD1 and SH\_X pins. The low-side sense is between the SH\_X and SL\_X pins. Ensuring a differential, low impedance connection to the external MOSFETs for these lines will help provide accurate VDS sensing.

The DRV8301 allows for both 6-PWM and 3-PWM control through a register setting.

**Table 1. 6-PWM Mode**

INL_X	INH_X	GL_X	GH_X
0	0	L	L
0	1	L	H
1	0	H	L
1	1	L	L

**Table 2. 3-PWM Mode**

INL_X	INH_X	GL_X	GH_X
X	0	H	L
X	1	L	H

**Table 3. Gate Driver External Components**

NAME	PIN 1	PIN 2	RECOMMENDED
R <sub>nOCTW</sub>	nOCTW	V <sub>CC</sub> <sup>(1)</sup>	≥10 kΩ
R <sub>nFAULT</sub>	nFAULT	V <sub>CC</sub> <sup>(1)</sup>	≥10 kΩ
R <sub>DTC</sub>	DTC	GND (PowerPAD)	0 to 150 kΩ (50 ns to 500 ns)
C <sub>GVDD</sub>	GVDD	GND (PowerPAD)	2.2 μF (20%) ceramic, ≥ 16 V
C <sub>CP</sub>	CP1	CP2	0.022 μF (20%) ceramic, rated for PVDD1
C <sub>DVDD</sub>	DVDD	AGND	1 μF (20%) ceramic, ≥ 6.3 V
C <sub>AVDD</sub>	AVDD	AGND	1 μF (20%) ceramic, ≥ 10 V
C <sub>PVDD1</sub>	PVDD1	GND (PowerPAD)	≥4.7 μF (20%) ceramic, rated for PVDD1
C <sub>BST_X</sub>	BST_X	SH_X	0.1 μF (20%) ceramic, ≥ 16 V

(1) V<sub>CC</sub> is the logic supply to the MCU

### 7.3.2 Current Shunt Amplifiers

The DRV8301 includes two high-performance current shunt amplifiers to accurate low-side, inline current measurement.

The current shunt amplifiers have four programmable GAIN settings through the SPI registers. These are 10, 20, 40, and 80 V/V.

The current shunt amplifiers provide output offset up to 3V to support bidirectional current sensing. The offset is set to half the voltage on the reference pin (REF).

To minimize DC offset and drift overtemperature, a calibration method is provided through either the DC\_CAL pin or SPI register. When DC calibration is enabled, the device will short the input of the current shunt amplifier and disconnect the load. DC calibration can be done at any time, even during MOSFET switching, because the load is disconnected. For the best results, perform the DC calibration during the switching OFF period, when no load is present, to reduce the potential noise impact to the amplifier.

The output of the current shunt amplifier can be calculated as:

$$V_O = \frac{V_{REF}}{2} - G \times (SN_x - SP_x)$$

where

- $V_{REF}$  is the reference voltage (REF pin)
- $G$  is the gain of the amplifier (10, 20, 40, or 80 V/V)
- $SN_x$  and  $SP_x$  are the inputs of channel  $x$ .  $SP_x$  should connect to the ground side of the sense resistor for the best common mode rejection. (1)

Figure 6 shows the current shunt amplifier simplified block diagram.

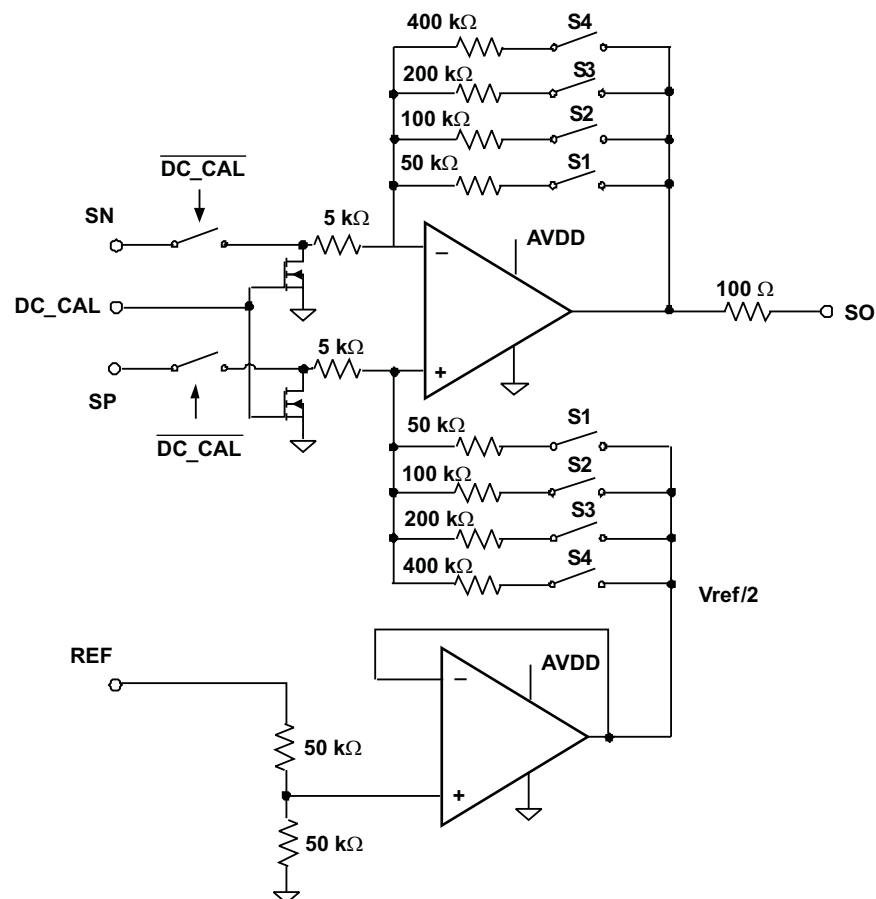

**Figure 6. Current Shunt Amplifier Simplified Block Diagram**

### 7.3.3 Buck Converter

**Table 4. Buck Regulator External Components**

NAME	PIN 1	PIN 2	RECOMMENDED
R <sub>RT_CLK</sub>	RT_CLK	GND (PowerPAD)	See <a href="#">Buck Converter</a>
C <sub>COMP</sub>	COMP	GND (PowerPAD)	See <a href="#">Buck Converter</a>
R <sub>C_COMP</sub>	COMP	GND (PowerPAD)	See <a href="#">Buck Converter</a>
R <sub>VSENSE1</sub>	PH (Filtered)	VSENSE	See <a href="#">Buck Converter</a>
R <sub>VSENSE2</sub>	VSENSE	GND (PowerPAD)	See <a href="#">Buck Converter</a>
R <sub>PWRGD</sub>	PWRGD	V <sub>CC</sub> <sup>(1)</sup>	≥ 10 kΩ
L <sub>PH</sub>	PH	PH (Filtered)	See <a href="#">Buck Converter</a>
D <sub>PH</sub>	PH	GND (PowerPAD)	See <a href="#">Buck Converter</a>
C <sub>PH</sub>	PH (Filtered)	GND (PowerPAD)	See <a href="#">Buck Converter</a>
C <sub>BST_BK</sub>	BST_BK	PH	See <a href="#">Buck Converter</a>
C <sub>PVDD2</sub>	PVDD2	GND (PowerPAD)	≥4.7 μF (20%) ceramic, rated for PVDD2
C <sub>SS_TR</sub>	SS_TR	GND (PowerPAD)	See <a href="#">Buck Converter</a>

(1) V<sub>CC</sub> is the logic supply to the MCU

### 7.3.4 Protection Features

#### 7.3.4.1 Overcurrent Protection and Reporting (OCP)

To protect the power stage from damage due to excessive currents, V<sub>DS</sub> sensing circuitry is implemented in the DRV8301. Based on the R<sub>DS(on)</sub> of the external MOSFETs and the maximum allowed I<sub>DS</sub>, a voltage threshold can be determined to trigger the overcurrent protection features when exceeded. The voltage threshold is programmed through the SPI registers. Overcurrent protection should be used as a protection scheme only; it is not intended as a precise current regulation scheme. There can be up to a 20% tolerance across channels for the V<sub>DS</sub> trip point.

$$V_{DS} = I_{DS} \times R_{DS(on)} \quad (2)$$

The V<sub>DS</sub> sense circuit measures the voltage from the drain to the source of the external MOSFET while the MOSFET is enabled. The high-side sense is between the PVDD1 and SH\_X pins. The low-side sense is between the SH\_X and SL\_X pins. Ensuring a differential, low impedance connection to the external MOSFETs for these lines will help provide accurate V<sub>DS</sub> sensing.

Four different overcurrent modes (OC\_MODE) can be set through the SPI registers. The OC status bits operate in latched mode. When an overcurrent condition occurs the corresponding OC status bit will latch in the DRV8301 registers until the next SPI read command. After the read command the OC status bit will clear from the register until another overcurrent condition occurs.

#### 1. Current limit mode

In current limit mode the device uses current limiting instead of device shutdown during an overcurrent event. In this mode the device reports overcurrent events through the nOCTW pin. The nOCTW pin will be held low for a maximum 64-μs period (internal timer) or until the next PWM cycle. If another overcurrent event is triggered from another MOSFET, during a previous overcurrent event, the reporting will continue for another 64-μs period (internal timer will restart) or until both PWM signals cycle. The associated status bit will be asserted for the MOSFET in which the overcurrent was detected.

There are two current control settings in current limit mode. These are set by one bit in the SPI registers. The default mode is cycle by cycle (CBC).

- Cycle by cycle mode (CBC): In CBC mode, the MOSFET on which overcurrent has been detected on will shut off until the next PWM cycle.
- Off-Time Control Mode: In Off-Time mode, the MOSFET in which overcurrent has been detected is disabled for a 64-μs period (set by internal timer). If overcurrent is detected in another MOSFET, the timer will be reset for another 64-μs period and both MOSFETs will be disabled for the duration. During this period, normal operation can be restored for a specific MOSFET with a corresponding PWM cycle.

#### 2. OC latch shut down mode

When an overcurrent event occurs, both the high-side and low-side MOSFETs will be disabled in the corresponding half-bridge. The nFAULT pin and nFAULT status bits will be asserted along with the associated status bit for the MOSFET in which the overcurrent was detected. The OC status bit will latch until the next SPI read command. The nFAULT pin and nFAULT status bit will latch until a reset is received through the GATE\_RESET bit or a quick EN\_GATE reset pulse.

### 3. Report only mode

No protective action will be taken in this mode when an overcurrent event occurs. The overcurrent event will be reported through the nOCTW pin (64- $\mu$ s pulse) and SPI status register. The external MCU should take action based on its own control algorithm.

### 4. OC disabled mode

The device will ignore and not report all overcurrent detections.

#### 7.3.4.2 Undervoltage Protection (PVDD\_UV and GVDD\_UV)

To protect the power output stage during start-up, shutdown, and other possible undervoltage conditions, the DRV8301 provides undervoltage protection by driving the gate drive outputs (GH\_X, GL\_X) low whenever PVDD or GVDD are below their undervoltage thresholds (PVDD\_UV/GVDD\_UV). This will put the external MOSFETs in a high impedance state. When the device is in PVDD\_UV it will not respond to SPI commands and the SPI registers will revert to their default settings.

A specific PVDD1 undervoltage transient brownout from 13  $\mu$ s to 15  $\mu$ s can cause the DRV8301 to become unresponsive to external inputs until a full power cycle. The transient condition consists of having PVDD1 greater than the PVDD\_UV level and then PVDD1 dropping below the PVDD\_UV level for a specific period of 13  $\mu$ s to 15  $\mu$ s. Transients shorter or longer than 13 to 15  $\mu$ s will not affect the normal operation of the undervoltage protection. Additional bulk capacitance can be added to PVDD1 to reduce undervoltage transients.

#### 7.3.4.3 Overvoltage Protection (GVDD\_OV)

The device will shut down both the gate driver and charge pump if the GVDD voltage exceeds the GVDD\_OV threshold to prevent potential issues related to the GVDD pin or the charge pump (e.g. short of external GVDD cap or charge pump). The fault is a latched fault and can only be reset through a reset transition on the EN\_GATE pin.

#### 7.3.4.4 Overtemperature Protection

A two-level overtemperature detection circuit is implemented:

- Level 1: Overtemperature warning (OTW)  
OTW is reported through the nOCTW pin (overcurrent and/or overtemperature warning) for default settings. OCTW pin can be set to report OTW or OCW only through the SPI registers. See SPI Register section.
- Level 2: Over Temperature Latched Shut Down of Gate Driver and Charge Pump (OTSD\_GATE)  
OTSD\_GATE is reported through the nFAULT pin. This is a latched shut down, so the gate driver will not recover automatically, even if the overtemperature condition is not present anymore. An EN\_GATE reset or SPI (RESET\_GATE) is required to recover the gate driver to normal operation after the temperature goes below a preset value,  $t_{OTSD\_CLR}$ .

SPI operation is still available and register settings will be remaining in the device during OTSD operation as long as PVDD1 is within the defined operation range.

#### 7.3.4.5 Fault and Protection Handling

The nFAULT pin indicates when a shutdown event has occurred. These events include overcurrent, overtemperature, overvoltage, or undervoltage. Note that nFAULT is an open-drain signal. nFAULT will go high when the gate driver is ready for PWM inputs during start-up.

The nOCTW pin indicates when an overcurrent event or over temperature event has occurred. These events are not necessarily related to a shutdown.

[Table 5](#) provides a summary of all the protection features and their reporting structure.

**Table 5. Fault and Warning Reporting and Handling**

EVENT	ACTION	LATCH	REPORTING ON nFAULT PIN	REPORTING ON nOCTW PIN	REPORTING IN SPI STATUS REGISTER
PVDD undervoltage	External FETs Hi-Z; Weak pulldown of all gate driver output	N	Y	N	Y
DVDD undervoltage	External FETs Hi-Z; Weak pulldown of all gate driver output; When recovering, reset all status registers	N	Y	N	N
GVDD undervoltage	External FETs Hi-Z; Weak pulldown of all gate driver output	N	Y	N	Y
GVDD overvoltage	External FETs Hi-Z; Weak pull down of all gate driver output Shut down the charge pump Won't recover and reset through SPI reset command or quick EN_GATE toggling	Y	Y	N	Y
OTW	None	N	N	Y (in default setting)	Y
OTSD_GATE	Gate driver latched shut down. Weak pulldown of all gate driver output to force external FETs Hi-Z Shut down the charge pump	Y	Y	Y	Y
OTSD_BUCK	OTSD of Buck	Y	N	N	N
Buck output undervoltage	UVLO_BUCK: auto-restart	N	Y (PWRGD pin)	N	N
Buck overload	Buck current limiting (Hi-Z high side until current reaches zero and then auto-recovering)	N	N	N	N
External FET overload – current limit mode	External FETs current Limiting (only OC detected FET)	N	N	Y	Y
External FET overload – Latch mode	Weak pulldown of gate driver output and PWM logic "0" of LS and HS in the same phase. External FETs Hi-Z	Y	Y	Y	Y
External FET overload – reporting only mode	Reporting only	N	N	Y	Y

### 7.3.5 Start-up and Shutdown Sequence Control

During power up all gate drive outputs are held low. Normal operation of gate driver and current shunt amplifiers can be initiated by toggling EN\_GATE from a low state to a high state. If no errors are present, the DRV8301 is ready to accept PWM inputs. Gate driver always has control of the power FETs even in gate disable mode as long as PVDD is within functional region.

There is an internal diode from SDO to VDD\_SPI, so VDD\_SPI is required to be powered to the same power level as other SPI devices (if there is any SDO signal from other devices) all the time. VDD\_SPI supply should be powered up first before any signal appears at SDO pin and powered down after completing all communications at SDO pin.

## 7.4 Device Functional Modes

### 7.4.1 EN\_GATE

EN\_GATE low is used to put gate driver, charge pump, current shunt amplifier, and internal regulator blocks into a low-power consumption mode to save energy. SPI communication is not supported during this state and the SPI registers will revert to their default settings after a full EN\_GATE reset. The device will put the MOSFET output stage to high-impedance mode as long as PVDD is still present.

When the EN\_GATE pin goes low to high, it will go through a power-up sequence, and enable gate driver, current amplifiers, charge pump, internal regulator, and so forth and reset all latched faults related to gate driver block. The EN\_GATE will also reset status registers in the SPI table. All latched faults can be reset when EN\_GATE is toggled after an error event unless the fault is still present.

When EN\_GATE goes from high to low, it will shut down gate driver block immediately, so gate output can put external FETs in high impedance mode. It will then wait for 10  $\mu$ s before completely shutting down the rest of the blocks. A quick fault reset mode can be done by toggling EN\_GATE pin for a very short period (less than 10  $\mu$ s). This will prevent the device from shutting down the other functional blocks such as charge pump and internal regulators and bring a quicker and simple fault recovery. SPI will still function with such a quick EN\_GATE reset mode. To perform a full reset, EN\_GATE should be toggled for longer than 20  $\mu$ s. This allows for all of the blocks to completely shut down and reach known states.

An EN\_GATE reset pulse (high  $\rightarrow$  low  $\rightarrow$  high) from 10 to 20  $\mu$ s should not be applied to the EN\_GATE pin. The DRV8301 has a transition area from the quick to full reset modes that can cause the device to become unresponsive to external inputs until a full power cycle. An RC filter can be added externally to the pin if reset pulses with this period are expected to occur on the EN\_GATE pin.

The other way to reset all of the faults is to use SPI command (RESET\_GATE), which will only reset gate driver block and all the SPI status registers without shutting down the other functional blocks.

One exception is to reset a GVDD\_OV fault. A quick EN\_GATE quick fault reset or SPI command reset will not work with GVDD\_OV fault. A complete EN\_GATE with low level holding longer than 20  $\mu$ s is required to reset GVDD\_OV fault. TI highly recommends to inspect the system and board when GVDD\_OV occurs.

### 7.4.2 DTC

Dead time can be programmed through DTC pin. A resistor should be connected from DTC to ground to control the dead time. Dead time control range is from 50 ns to 500 ns. Short DTC pin to ground will provide minimum dead time (50 ns). Resistor range is 0 to 150 k $\Omega$ . Dead time is linearly set over this resistor range.

Current shoot through prevention protection will be enabled in the device all time independent of dead time setting and input mode setting.

### 7.4.3 VDD\_SPI

VDD\_SPI is the power supply to power SDO pin. It has to be connected to the same power supply (3.3 V or 5 V) that MCU uses for its SPI operation.

During power up or down transient, VDD\_SPI pin could be zero voltage shortly. During this period, no SDO signal should be present at SDO pin from any other devices in the system because it causes a parasitic diode in the DRV8301 conducting from SDO to VDD\_SPI pin as a short. This should be considered and prevented from system power sequence design.

## 7.5 Programming

### 7.5.1 SPI Communication

#### 7.5.1.1 SPI

The DRV8301 SPI operates as a slave. The SPI input (SDI) data format consists of a 16 bit word with 1 read/write bit, 4 address bits, and 11 data bits. The SPI output (SDO) data format consists of a 16 bit word with 1 frame fault bit, 4 address bits, and 11 data bits. When a frame is not valid, frame fault bit will set to 1 and the remaining bits will shift out as 0.

A valid frame must meet following conditions:

- Clock must be low when nSCS goes low.
- Should have 16 full clock cycles.
- Clock must be low when nSCS goes high.

When nSCS is asserted high, any signals at the SCLK and SDI pins are ignored and SDO is forced into a high impedance state. When nSCS transitions from HIGH to LOW, SDO is enabled and the SDO response word loads into the shift register based on the previous SPI input word.

The SCLK pin must be low when nSCS transitions low. While nSCS is low, at each rising edge of the clock the response word is serially shifted out on the SDO pin with the MSB shifted out first.

While SCS is low, at each falling edge of the clock the new input word is sampled on the SDI pin. The SPI input word is decoded to determine the register address and access type (read or write). The MSB will be shifted in first. Any amount of time may pass between bits, as long as nSCS stays active low. This allows two 8-bit words to be used. If the input word sent to SDI is less than 16 bits or more than 16 bits, it is considered a frame error. If it is a write command, the data will be ignored. The fault bit in the next SDO response word will then report 1. After the 16th clock cycle or when nSCS transitions from LOW to HIGH, the SDI shift register data is transferred into a latch where the input word is decoded.

For a READ command (Nth cycle) sent to SDI, SDO will respond with the data at the specified address in the next cycle. (N+1)

For a WRITE command (Nth cycle) sent to SDI, SDO will respond with the data in Status Register 1 (0x00) in the next cycle (N+1). This feature is intended to maximize SPI communication efficiency when having multiple write commands.

#### 7.5.1.2 SPI Format

The SDI input data word is 16 bits long and consists of:

- 1 read/write bit W [15]
- 4 address bits A [14:11]
- 11 data bits D [10:0]

The SDO output data word is 16 bits long and consists of:

- 1 fault frame bit F [15]
- 4 address bits A [14:11]
- 11 data bits D [10:0]

The SDO output word (Nth cycle) is in response to the previous SDI input word (N-1 cycle).

Therefore each SPI Query/Response pair requires two full 16 bit shift cycles to complete.

**Table 6. SPI Input Data Control Word Format**

	R/W	ADDRESS				DATA										
Word Bit	B15	B14	B13	B12	B11	B10	B9	B8	B7	B6	B5	B4	B3	B2	B1	B0
Command	W0	A3	A2	A1	A0	D10	D9	D8	D7	D6	D5	D4	D3	D2	D1	D0

**Table 7. SPI Output Data Response Word Format**

	R/W	DATA														
Word Bit	B15	B14	B13	B12	B11	B10	B9	B8	B7	B6	B5	B4	B3	B2	B1	B0
Command	F0	A3	A2	A1	A0	D10	D9	D8	D7	D6	D5	D4	D3	D2	D1	D0

## 7.6 Register Maps

### 7.6.1 Read / Write Bit

The MSB bit of the SDI input word (W0) is a read/write bit. When W0 = 0, the input word is a write command. When W0 = 1, input word is a read command.

### 7.6.2 Address Bits

**Table 8. Register Address**

REGISTER TYPE	ADDRESS [A3..A0]				REGISTER NAME	DESCRIPTION	READ AND WRITE ACCESS
Status Register	0	0	0	0	Status Register 1	Status register for device faults	R
	0	0	0	1	Status Register 2	Status register for device faults and ID	R
Control Register	0	0	1	0	Control Register 1		R/W
	0	0	1	1	Control Register 2		R/W

### 7.6.3 SPI Data Bits

#### 7.6.3.1 Status Registers

**Table 9. Status Register 1 (Address: 0x00) (All Default Values are Zero)**

ADDRESS	REGISTER NAME	D10	D9	D8	D7	D6	D5	D4	D3	D2	D1	D0
0x00	Status Register 1	FAULT	GVDD_UV	PVDD_UV	OTSD	OTW	FETHA_OC	FETLA_OC	FETHB_OC	FETLB_OC	FETHC_OC	FETLC_OC

**Table 10. Status Register 2 (Address: 0x01) (All Default Values are Zero)**

ADDRESS	REGISTER NAME	D10	D9	D8	D7	D6	D5	D4	D3	D2	D1	D0
0x01	Status Register 2				GVDD_OV				Device ID [3]	Device ID [2]	Device ID [1]	Device ID [0]

#### 7.6.3.2 Control Registers

**Table 11. Control Register 1 for Gate Driver Control (Address: 0x02)<sup>(1)</sup>**

ADDRESS	NAME	DESCRIPTION	D10	D9	D8	D7	D6	D5	D4	D3	D2	D1	D0	
0x02	GATE_CURRENT	Gate drive peak current 1.7 A										0 <sup>(1)</sup>	0 <sup>(1)</sup>	
		Gate drive peak current 0.7 A										0	1	
		Gate drive peak current 0.25 A										1	0	
		Reserved										1	1	
	GATE_RESET	Normal mode										0 <sup>(1)</sup>		
		Reset gate driver latched faults (reverts to 0)										1		
	PWM_MODE	6 PWM inputs (see Table 1)									0 <sup>(1)</sup>			
		3 PWM inputs (see Table 2)									1			
	OCP_MODE	Current limit							0 <sup>(1)</sup>	0 <sup>(1)</sup>				
		OC latch shut down							0	1				
		Report only							1	0				
		OC disabled							1	1				
OC_ADJ_SET	See OC_ADJ_SET table		X	X	X	X	X							

(1) Default value

**Table 12. Control Register 2 for Current Shunt Amplifiers and Misc Control (Address: 0x03)<sup>(1)</sup>**

ADDRESS	NAME	DESCRIPTION	D10	D9	D8	D7	D6	D5	D4	D3	D2	D1	D0	
0x03	OCTW_MODE	Report both OT and OC at nOCTW pin										0 <sup>(1)</sup>	0 <sup>(1)</sup>	
		Report OT only										0	1	
		Report OC only										1	0	
		Report OC only (reserved)										1	1	
	GAIN	Gain of shunt amplifier: 10 V/V									0 <sup>(1)</sup>	0 <sup>(1)</sup>		
		Gain of shunt amplifier: 20 V/V									0	1		
		Gain of shunt amplifier: 40 V/V									1	0		
		Gain of shunt amplifier: 80 V/V									1	1		
	DC_CAL_CH1	Shunt amplifier 1 connects to load through input pins								0 <sup>(1)</sup>				
		Shunt amplifier 1 shorts input pins and disconnects from load for external calibration								1				
	DC_CAL_CH2	Shunt amplifier 2 connects to load through input pins							0 <sup>(1)</sup>					
		Shunt amplifier 2 shorts input pins and disconnects from load for external calibration							1					
	OC_TOFF	Cycle by cycle						0 <sup>(1)</sup>						
		Off-time control						1						
	Reserved													

(1) Default value

### 7.6.3.3 Overcurrent Adjustment

**Table 13. OC\_ADJ\_SET Table**

Control Bit (D6–D10) (0xH)	0	1	2	3	4	5	6	7
Vds (V)	0.060	0.068	0.076	0.086	0.097	0.109	0.123	0.138
Control Bit (D6–D10) (0xH)	8	9	10	11	12	13	14	15
Vds (V)	0.155	0.175	0.197	0.222	0.250	0.282	0.317	0.358
Control Bit (D6–D10) (0xH)	16	17	18	19	20	21	22	23
Vds (V)	0.403	0.454	0.511	0.576	0.648	0.730	0.822	0.926
Code Number (0xH)	24	25	26	27	28	29	30	31
Vds (V)	1.043	1.175	1.324	1.491	1.679 <sup>(1)</sup>	1.892 <sup>(1)</sup>	2.131 <sup>(1)</sup>	2.400 <sup>(1)</sup>

(1) Do not use settings 28, 29, 30, 31 for V<sub>DS</sub> sensing if the IC is expected to operate in the 6-V to 8-V range.

## 8 Application and Implementation

---

### NOTE

Information in the following applications sections is not part of the TI component specification, and TI does not warrant its accuracy or completeness. TI's customers are responsible for determining suitability of components for their purposes. Customers should validate and test their design implementation to confirm system functionality.

---

### 8.1 Application Information

The DRV8301 is a gate driver designed to drive a 3-phase BLDC motor in combination with external power MOSFETs. The device provides a high level of integration with three half-bridge gate drivers, two current shunt amplifiers, and overcurrent protection.

#### 8.1.1 Gate Driver Power-Up Sequencing Errata

The DRV8301 gate drivers may not correctly power up if a voltage greater than 8.5 V is present on any SH\_X pin when EN\_GATE is brought logic high (device enabled) after PVDD1 power is applied ( $PVDD1 > PVDD_{UV}$ ). This sequence should be avoided by ensuring the voltage levels on the SH\_X pins are less than 8.5 V when the DRV8301 is enabled through EN\_GATE.



## Typical Application (continued)

### 8.2.1 Design Requirements

Table 14 shows the design parameters for this application.

**Table 14. Design Parameters**

DESIGN PARAMETER	REFERENCE	VALUE
Supply voltage	PVDD	24 V
Motor winding resistance	$M_R$	0.5 $\Omega$
Motor winding inductance	$M_L$	0.28 mH
Motor poles	$M_P$	16 poles
Motor rated RPM	$M_{RPM}$	4000 RPM
Target full-scale current	$I_{MAX}$	14 A
Sense resistor	$R_{SENSE}$	0.01 $\Omega$
MOSFET $Q_g$	$Q_g$	29 nC
MOSFET $R_{DS(on)}$	$R_{DS(on)}$	4.7 m $\Omega$
VDS trip level	OC_ADJ_SET	0.123 V
Switching frequency	$f_{SW}$	45 kHz
Series gate resistance	$R_{GATE}$	10 $\Omega$
Amplifier reference	$V_{REF}$	3.3 V
Amplifier gain	Gain	10 V/V

### 8.2.2 Detailed Design Procedure

#### 8.2.2.1 Gate Drive Average Current Load

The gate drive supply (GVDD) of the DRV8301 can deliver up to 30 mA (RMS) of current to the external power MOSFETs. Use Equation 3 to determine the approximate RMS load on the gate drive supply:

$$\text{Gate Drive RMS Current} = \text{MOSFET } Q_g \times \text{Number of Switching MOSFETs} \times \text{Switching Frequency} \quad (3)$$

Example:

$$7.83 \text{ mA} = 29 \text{ nC} \times 6 \times 45 \text{ kHz} \quad (4)$$

This is a rough approximation only.

#### 8.2.2.2 Overcurrent Protection Setup

The DRV8301 provides overcurrent protection for the external power MOSFETs through the use of  $V_{DS}$  monitors for both the high side and low side MOSFETs. These are intended for protecting the MOSFET in overcurrent conditions and not for precise current regulation.

The overcurrent protection works by monitoring the  $V_{DS}$  voltage of the external MOSFET and comparing it against the OC\_ADJ\_SET register value. If the  $V_{DS}$  exceeds the OC\_ADJ\_SET value the DRV8301 takes action according to the OC\_MODE register.

$$\text{Overcurrent Trip} = \text{OC\_ADJ\_SET} / \text{MOSFET } R_{DS(on)} \quad (5)$$

Example:

$$26.17 \text{ A} = 0.123 \text{ V} / 4.7 \text{ m}\Omega \quad (6)$$

MOSFET  $R_{DS(on)}$  changes with temperature and this will affect the overcurrent trip level.

#### 8.2.2.3 Sense Amplifier Setup

The DRV8301 provides two bidirectional low-side current shunt amplifiers. These can be used to sense a sum of the three half-bridges, two of the half-bridges individually, or in conjunction with an additional shunt amplifier to sense all three half-bridges individually.

1. Determine the peak current that the motor will demand ( $I_{MAX}$ ). This will be dependent on the motor parameters and your specific application.  $I_{MAX}$  in this example is 14 A.
2. Determine the available voltage range for the current shunt amplifier. This will be  $\pm$  half of the amplifier

reference voltage ( $V_{REF}$ ). In this case the available range is  $\pm 1.65$  V.

- Determine the sense resistor value and amplifier gain settings. There are common tradeoffs for both the sense resistor value and amplifier gain. The larger the sense resistor value, the better the resolution of the half-bridge current. This comes at the cost of additional power dissipated from the sense resistor. A larger gain value will allow you to decrease the sense resistor, but at the cost of increased noise in the output signal. This example uses a  $0.01 \Omega$  sense resistor and the minimum gain setting of the DRV8301 (10 V/V). These values allow the current shunt amplifiers to measure  $\pm 16.5$  A (some additional margin on the 14 A requirement).

### 8.2.3 Application Curves

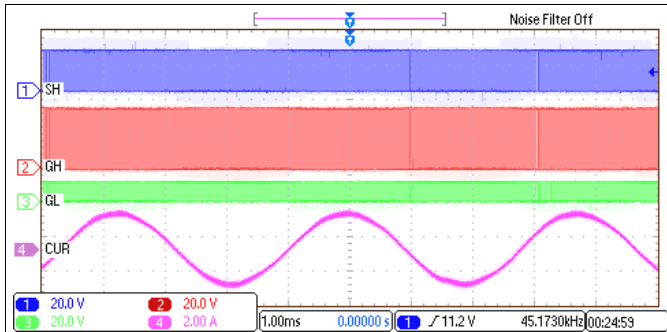

Figure 8. Motor Spinning 2000 RPM

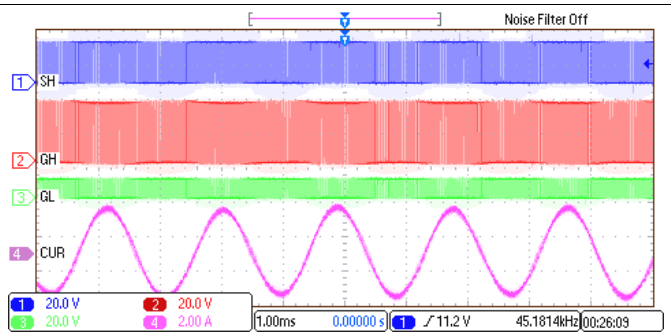

Figure 9. Motor Spinning 4000 RPM

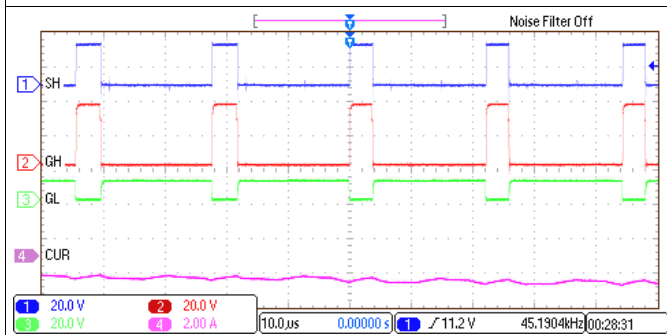

Figure 10. Gate Drive 20% Duty Cycle

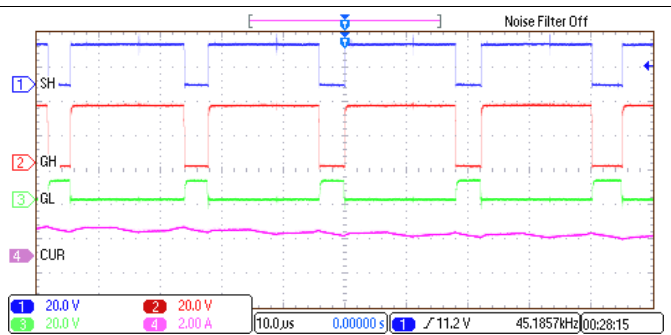

Figure 11. Gate Drive 80% Duty Cycle

## 9 Power Supply Recommendations

### 9.1 Bulk Capacitance

Having appropriate local bulk capacitance is an important factor in motor drive system design. It is generally beneficial to have more bulk capacitance, while the disadvantages are increased cost and physical size.

The amount of local capacitance needed depends on a variety of factors, including:

- The highest current required by the motor system
- The capacitance of the power supply and its ability to source or sink current
- The amount of parasitic inductance between the power supply and motor system
- The acceptable voltage ripple
- The type of motor used (brushed DC, brushless DC, stepper)
- The motor braking method

The inductance between the power supply and motor drive system will limit the rate current can change from the power supply. If the local bulk capacitance is too small, the system will respond to excessive current demands or dumps from the motor with a change in voltage. When adequate bulk capacitance is used, the motor voltage remains stable and high current can be quickly supplied.

The data sheet generally provides a recommended value, but system-level testing is required to determine the appropriate sized bulk capacitor.

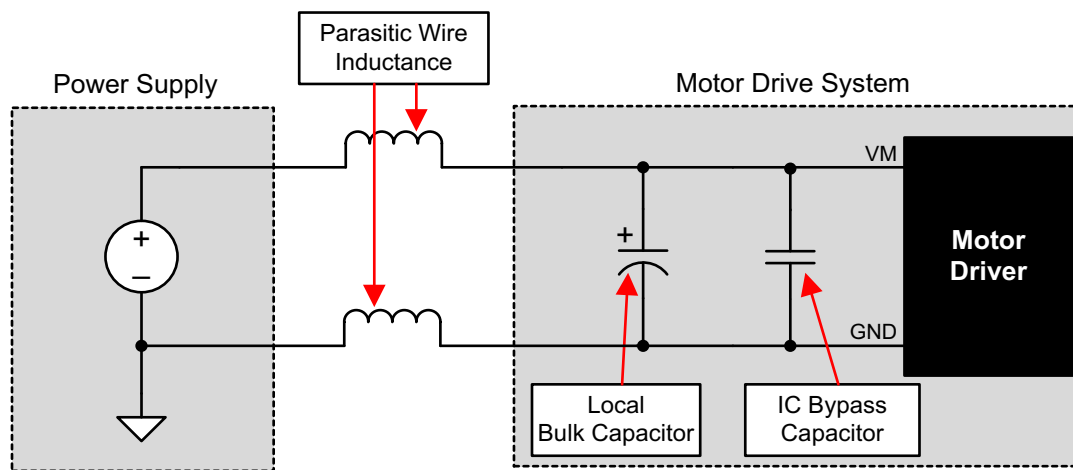

**Figure 12. Example Setup of Motor Drive System With External Power Supply**

The voltage rating for bulk capacitors should be higher than the operating voltage, to provide margin for cases when the motor transfers energy to the supply.

## 10 Layout

### 10.1 Layout Guidelines

Use these layout recommendations when designing a PCB for the DRV8301.

- The DRV8301 makes an electrical connection to GND through the PowerPAD. Always check to ensure that the PowerPAD has been properly soldered (See *PowerPAD™ Thermally Enhanced Package* application report, [SLMA002](#)).
- PVDD bypass capacitors should be placed close to their corresponding pins with a low impedance path to device GND (PowerPAD).
- GVDD bypass capacitor should be placed close its corresponding pin with a low impedance path to device GND (PowerPAD).
- AVDD and DVDD bypass capacitors should be placed close to their corresponding pins with a low-impedance path to the AGND pin. It is preferable to make this connection on the same layer.
- AGND should be tied to device GND (PowerPAD) through a low impedance trace/copper fill.
- Add stitching vias to reduce the impedance of the GND path from the top to bottom side.
- Try to clear the space around and underneath the DRV8301 to allow for better heat spreading from the PowerPAD.

## 10.2 Layout Example

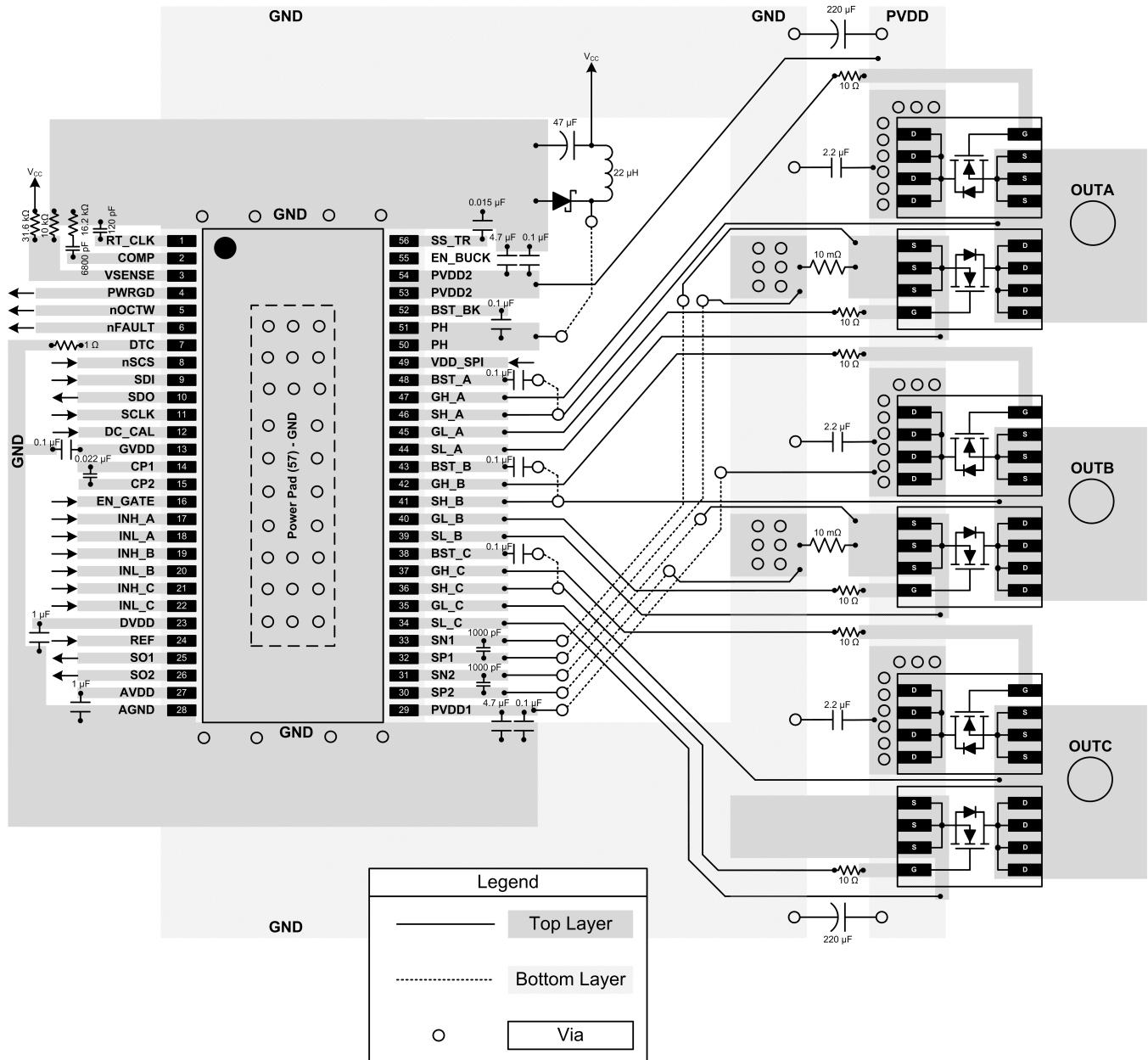

Figure 13. Top and Bottom Layer Layout Schematic

## 11 Device and Documentation Support

### 11.1 Documentation Support

#### 11.1.1 Related Documentation

For related documentation see the following:

- *Semiconductor and IC Package Thermal Metrics* application report, [SPRA953](#)
- *PowerPAD™ Thermally Enhanced Package* application report, [SLMA002](#)

### 11.2 Community Resources

The following links connect to TI community resources. Linked contents are provided "AS IS" by the respective contributors. They do not constitute TI specifications and do not necessarily reflect TI's views; see TI's [Terms of Use](#).

**TI E2E™ Online Community** *TI's Engineer-to-Engineer (E2E) Community*. Created to foster collaboration among engineers. At [e2e.ti.com](#), you can ask questions, share knowledge, explore ideas and help solve problems with fellow engineers.

**Design Support** *TI's Design Support* Quickly find helpful E2E forums along with design support tools and contact information for technical support.

### 11.3 Trademarks

PowerPAD, E2E are trademarks of Texas Instruments.  
All other trademarks are the property of their respective owners.

### 11.4 Electrostatic Discharge Caution



These devices have limited built-in ESD protection. The leads should be shorted together or the device placed in conductive foam during storage or handling to prevent electrostatic damage to the MOS gates.

### 11.5 Glossary

[SLYZ022](#) — *TI Glossary*.

This glossary lists and explains terms, acronyms, and definitions.

## 12 Mechanical, Packaging, and Orderable Information

The following pages include mechanical, packaging, and orderable information. This information is the most current data available for the designated devices. This data is subject to change without notice and revision of this document. For browser-based versions of this data sheet, refer to the left-hand navigation.

**PACKAGING INFORMATION**

Orderable Device	Status (1)	Package Type	Package Drawing	Pins	Package Qty	Eco Plan (2)	Lead finish/ Ball material (6)	MSL Peak Temp (3)	Op Temp (°C)	Device Marking (4/5)	Samples
DRV8301DCA	ACTIVE	HTSSOP	DCA	56	35	RoHS & Green	NIPDAU	Level-3-260C-168 HR	-40 to 125	DRV8301	<a href="#">Samples</a>
DRV8301DCAR	ACTIVE	HTSSOP	DCA	56	2000	RoHS & Green	NIPDAU	Level-3-260C-168 HR	-40 to 125	DRV8301	<a href="#">Samples</a>

(1) The marketing status values are defined as follows:

**ACTIVE:** Product device recommended for new designs.

**LIFEBUY:** TI has announced that the device will be discontinued, and a lifetime-buy period is in effect.

**NRND:** Not recommended for new designs. Device is in production to support existing customers, but TI does not recommend using this part in a new design.

**PREVIEW:** Device has been announced but is not in production. Samples may or may not be available.

**OBSOLETE:** TI has discontinued the production of the device.

(2) **RoHS:** TI defines "RoHS" to mean semiconductor products that are compliant with the current EU RoHS requirements for all 10 RoHS substances, including the requirement that RoHS substance do not exceed 0.1% by weight in homogeneous materials. Where designed to be soldered at high temperatures, "RoHS" products are suitable for use in specified lead-free processes. TI may reference these types of products as "Pb-Free".

**RoHS Exempt:** TI defines "RoHS Exempt" to mean products that contain lead but are compliant with EU RoHS pursuant to a specific EU RoHS exemption.

**Green:** TI defines "Green" to mean the content of Chlorine (Cl) and Bromine (Br) based flame retardants meet JS709B low halogen requirements of <=1000ppm threshold. Antimony trioxide based flame retardants must also meet the <=1000ppm threshold requirement.

(3) MSL, Peak Temp. - The Moisture Sensitivity Level rating according to the JEDEC industry standard classifications, and peak solder temperature.

(4) There may be additional marking, which relates to the logo, the lot trace code information, or the environmental category on the device.

(5) Multiple Device Markings will be inside parentheses. Only one Device Marking contained in parentheses and separated by a "~" will appear on a device. If a line is indented then it is a continuation of the previous line and the two combined represent the entire Device Marking for that device.

(6) Lead finish/Ball material - Orderable Devices may have multiple material finish options. Finish options are separated by a vertical ruled line. Lead finish/Ball material values may wrap to two lines if the finish value exceeds the maximum column width.

**Important Information and Disclaimer:**The information provided on this page represents TI's knowledge and belief as of the date that it is provided. TI bases its knowledge and belief on information provided by third parties, and makes no representation or warranty as to the accuracy of such information. Efforts are underway to better integrate information from third parties. TI has taken and continues to take reasonable steps to provide representative and accurate information but may not have conducted destructive testing or chemical analysis on incoming materials and chemicals. TI and TI suppliers consider certain information to be proprietary, and thus CAS numbers and other limited information may not be available for release.

In no event shall TI's liability arising out of such information exceed the total purchase price of the TI part(s) at issue in this document sold by TI to Customer on an annual basis.

**OTHER QUALIFIED VERSIONS OF DRV8301 :**

- Automotive: [DRV8301-Q1](#)

## NOTE: Qualified Version Definitions:

- Automotive - Q100 devices qualified for high-reliability automotive applications targeting zero defects

**TAPE AND REEL INFORMATION**

**QUADRANT ASSIGNMENTS FOR PIN 1 ORIENTATION IN TAPE**



\*All dimensions are nominal

Device	Package Type	Package Drawing	Pins	SPQ	Reel Diameter (mm)	Reel Width W1 (mm)	A0 (mm)	B0 (mm)	K0 (mm)	P1 (mm)	W (mm)	Pin1 Quadrant
DRV8301DCAR	HTSSOP	DCA	56	2000	330.0	24.4	8.6	15.6	1.8	12.0	24.0	Q1

**TAPE AND REEL BOX DIMENSIONS**

\*All dimensions are nominal

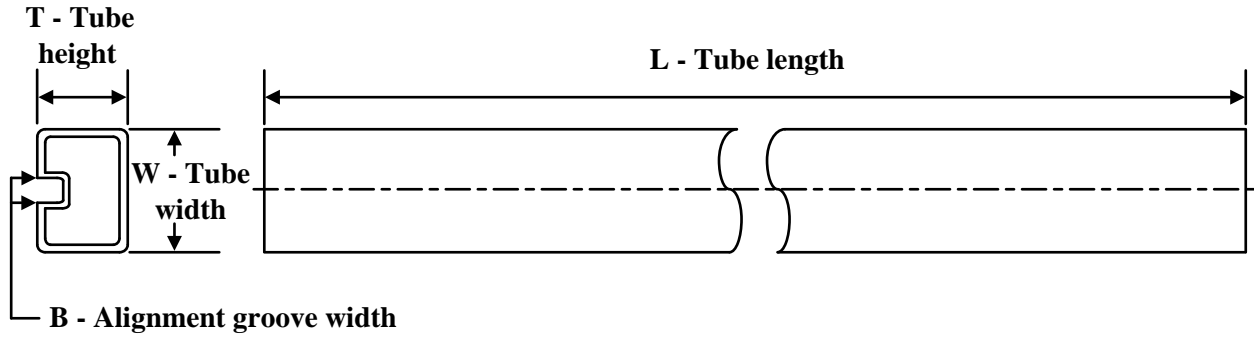
Device	Package Type	Package Drawing	Pins	SPQ	Length (mm)	Width (mm)	Height (mm)
DRV8301DCAR	HTSSOP	DCA	56	2000	350.0	350.0	43.0

**TUBE**

\*All dimensions are nominal

Device	Package Name	Package Type	Pins	SPQ	L (mm)	W (mm)	T (μm)	B (mm)
DRV8301DCA	DCA	HTSSOP	56	35	530	11.89	3600	4.9

# MECHANICAL DATA

DCA (R-PDSO-G56)

PowerPAD™ PLASTIC SMALL-OUTLINE

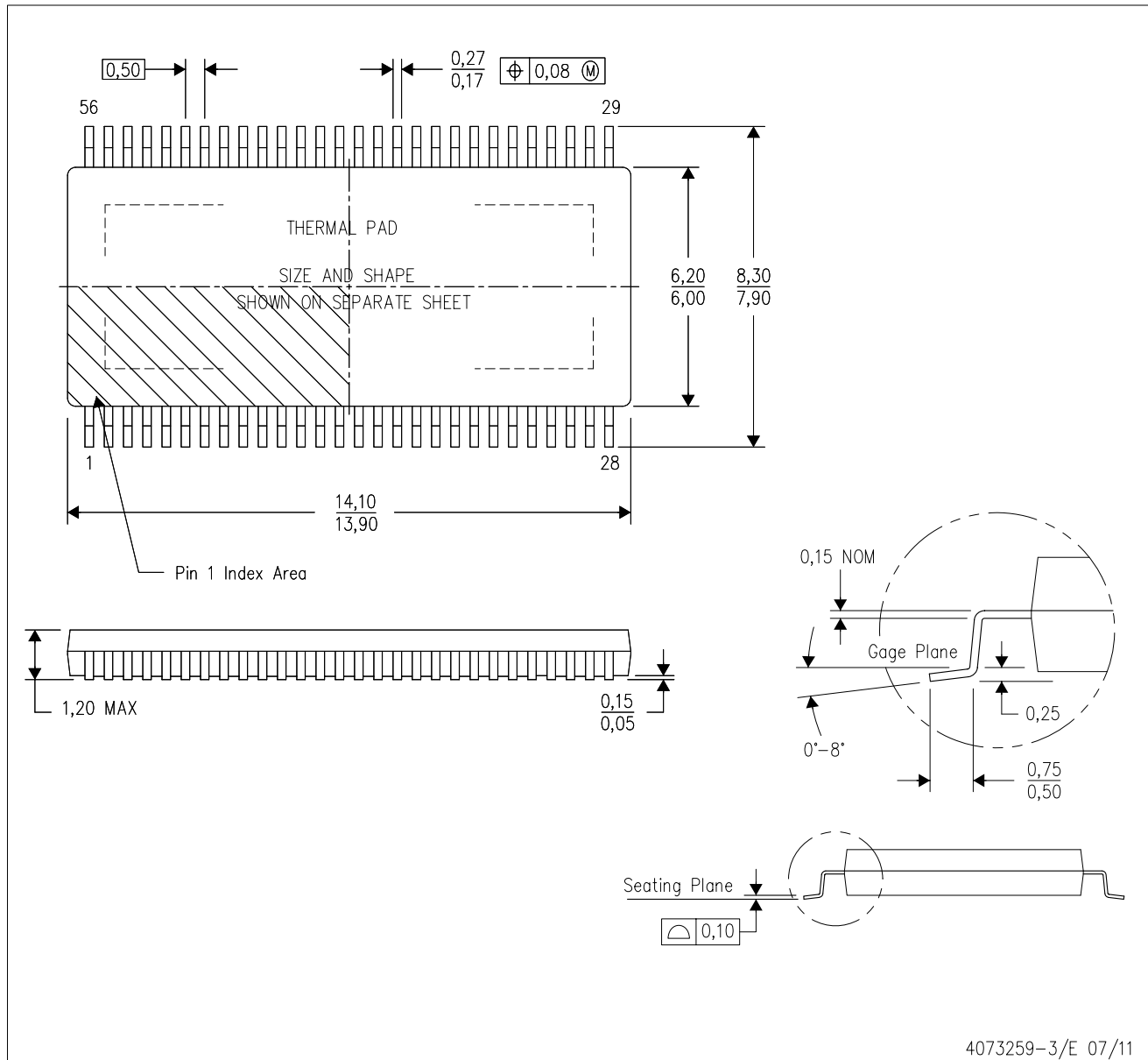

- NOTES:
- All linear dimensions are in millimeters. Dimensioning and tolerancing per ASME Y14.5M-1994.
  - This drawing is subject to change without notice.
  - Body dimensions do not include mold flash or protrusion not to exceed 0,15.
  - This package is designed to be soldered to a thermal pad on the board. Refer to Technical Brief, PowerPad Thermally Enhanced Package, Texas Instruments Literature No. SLMA002 for information regarding recommended board layout. This document is available at [www.ti.com](http://www.ti.com) <<http://www.ti.com>>.
  - See the additional figure in the Product Data Sheet for details regarding the exposed thermal pad features and dimensions.
  - Falls within JEDEC MO-153

PowerPAD is a trademark of Texas Instruments.

# THERMAL PAD MECHANICAL DATA

DCA (R-PDSO-G56)

PowerPAD™ PLASTIC SMALL OUTLINE

## THERMAL INFORMATION

This PowerPAD™ package incorporates an exposed thermal pad that is designed to be attached to a printed circuit board (PCB). The thermal pad must be soldered directly to the PCB. After soldering, the PCB can be used as a heatsink. In addition, through the use of thermal vias, the thermal pad can be attached directly to the appropriate copper plane shown in the electrical schematic for the device, or alternatively, can be attached to a special heatsink structure designed into the PCB. This design optimizes the heat transfer from the integrated circuit (IC).

For additional information on the PowerPAD package and how to take advantage of its heat dissipating abilities, refer to Technical Brief, PowerPAD Thermally Enhanced Package, Texas Instruments Literature No. SLMA002 and Application Brief, PowerPAD Made Easy, Texas Instruments Literature No. SLMA004. Both documents are available at [www.ti.com](http://www.ti.com).

The exposed thermal pad dimensions for this package are shown in the following illustration.

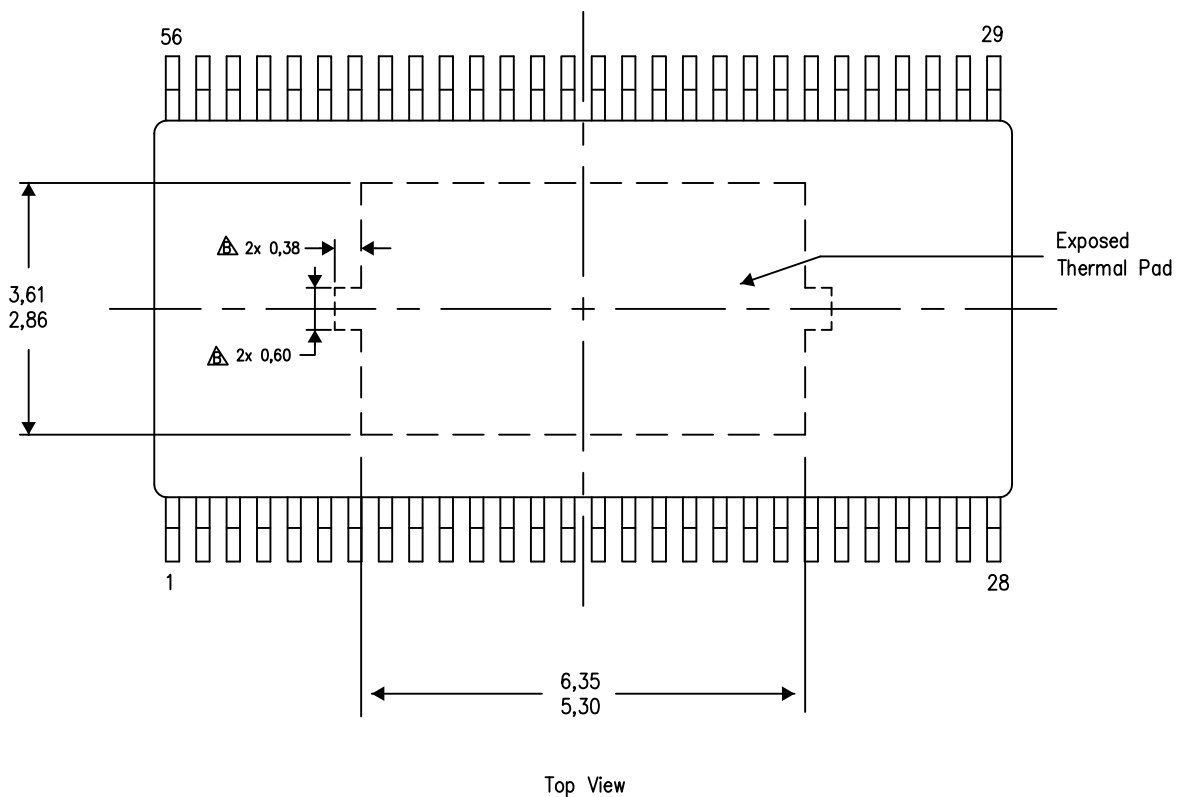

Exposed Thermal Pad Dimensions

4206320-15/S 11/14

NOTES: A. All linear dimensions are in millimeters

- △ Keep-out features are identified to prevent board routing interference. These exposed metal features may vary within the identified area or completely absent on some devices.

PowerPAD is a trademark of Texas Instruments.

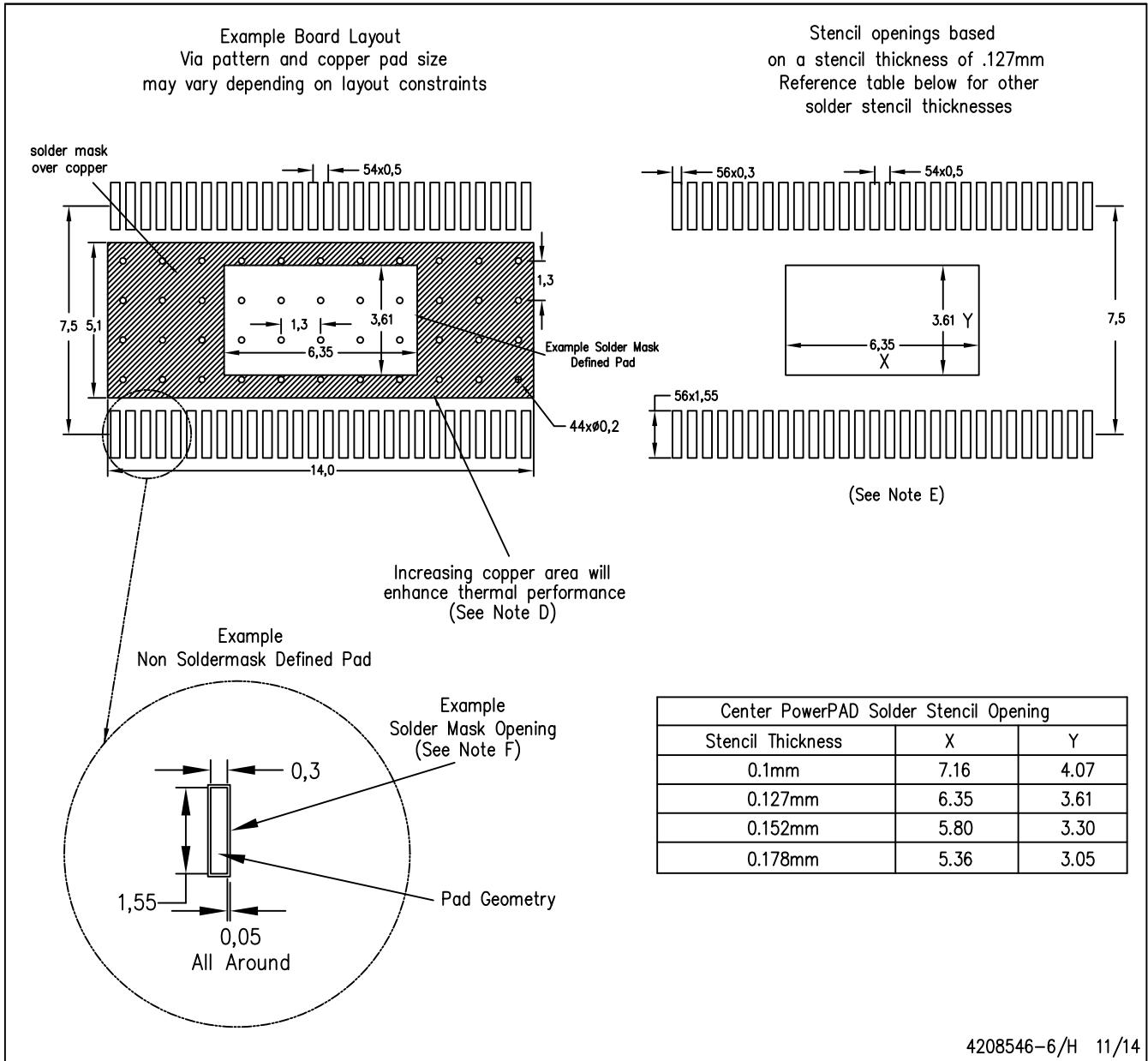

4208546-6/H 11/14

- NOTES:
- A. All linear dimensions are in millimeters.
  - B. This drawing is subject to change without notice.
  - C. Customers should place a note on the circuit board fabrication drawing not to alter the center solder mask defined pad.
  - D. This package is designed to be soldered to a thermal pad on the board. Refer to Technical Brief, PowerPAD Thermally Enhanced Package, Texas Instruments Literature No. SLMA002, SLMA004, and also the Product Data Sheets for specific thermal information, via requirements, and recommended board layout. These documents are available at [www.ti.com](http://www.ti.com) <<http://www.ti.com>>. Publication IPC-7351 is recommended for alternate designs.
  - E. Laser cutting apertures with trapezoidal walls and also rounding corners will offer better paste release. Customers should contact their board assembly site for stencil design recommendations. Example stencil design based on a 50% volumetric metal load solder paste. Refer to IPC-7525 for other stencil recommendations.
  - F. Customers should contact their board fabrication site for solder mask tolerances between and around signal pads.

## IMPORTANT NOTICE AND DISCLAIMER

TI PROVIDES TECHNICAL AND RELIABILITY DATA (INCLUDING DATA SHEETS), DESIGN RESOURCES (INCLUDING REFERENCE DESIGNS), APPLICATION OR OTHER DESIGN ADVICE, WEB TOOLS, SAFETY INFORMATION, AND OTHER RESOURCES "AS IS" AND WITH ALL FAULTS, AND DISCLAIMS ALL WARRANTIES, EXPRESS AND IMPLIED, INCLUDING WITHOUT LIMITATION ANY IMPLIED WARRANTIES OF MERCHANTABILITY, FITNESS FOR A PARTICULAR PURPOSE OR NON-INFRINGEMENT OF THIRD PARTY INTELLECTUAL PROPERTY RIGHTS.

These resources are intended for skilled developers designing with TI products. You are solely responsible for (1) selecting the appropriate TI products for your application, (2) designing, validating and testing your application, and (3) ensuring your application meets applicable standards, and any other safety, security, regulatory or other requirements.

These resources are subject to change without notice. TI grants you permission to use these resources only for development of an application that uses the TI products described in the resource. Other reproduction and display of these resources is prohibited. No license is granted to any other TI intellectual property right or to any third party intellectual property right. TI disclaims responsibility for, and you will fully indemnify TI and its representatives against, any claims, damages, costs, losses, and liabilities arising out of your use of these resources.

TI's products are provided subject to [TI's Terms of Sale](#) or other applicable terms available either on [ti.com](https://www.ti.com) or provided in conjunction with such TI products. TI's provision of these resources does not expand or otherwise alter TI's applicable warranties or warranty disclaimers for TI products.

TI objects to and rejects any additional or different terms you may have proposed.

Mailing Address: Texas Instruments, Post Office Box 655303, Dallas, Texas 75265  
Copyright © 2023, Texas Instruments Incorporated

## Looking for pricing, stock, or lifecycle information?

Click below to explore more details on WIN SOURCE:

 [View DRV8301DCAR on WIN SOURCE](#)

 [Texas Instruments](#) Information

## Optimize Your Supply Chain with WIN SOURCE Solutions

-  Global Sourcing Solution
-  Obsolete Management
-  Cost Control Management
-  Shortage Management
-  Alternative Solution
-  Excess Inventory Management