



**THE DATASHEET OF
NLV32T-3R9J-EFD**



9-CHANNEL RS-422 / RS-485 TRANSCEIVER

FEATURES

- **Designed to Operate at up to 20 Million Data Transfers per Second on Each RS-422/RS-485 Channel**
- **SN65HVD09 Packaged in Thin Shrink Small-Outline Package with 0.5-mm Pin Pitch**
- **ESD Protection on Bus Pins Exceeds 12kV**
- **Low Disabled Supply Current 8 mA Typ**
- **Thermal Shutdown Protection**
- **Positive- and Negative-Current Limiting**
- **Power-Up/Down Glitch Protection**

DESCRIPTION

The SN65HVD09 is a 9-channel RS-422 / RS-485 transceiver suitable for industrial applications. It offers improved switching performance, a small package, and high ESD protection. The precise skew limits ensures that the propagation delay times, not only from channel-to-channel but from device-to-device, are closely matched for the tight skew budgets associated with high-speed parallel data buses.

Patented thermal enhancements are used in the thin shrink, small-outline package (TSSOP), allowing operation over the industrial temperature range. The TSSOP package offers very small board area requirements while reducing the package height to 1 mm. This provides more board area and allows component mounting to both sides of the printed circuit boards for low-profile, space-restricted applications such as small form-factor hard disk drives.

The HVD09 can withstand electrostatic discharges exceeding 12 kV using the human-body model, and 600 V using the machine model on the RS-485 I/O terminals. This provides protection from the noise that can be coupled into external cables. The other terminals of the device can withstand discharges exceeding 4 kV and 400 V respectively.

Each of the nine half-duplex channels of the HVD09 is designed to operate with either RS-422 or RS-485 communication networks.

The SN65HVD09 is characterized for operation over an ambient air temperature range of -40°C to 85°C .

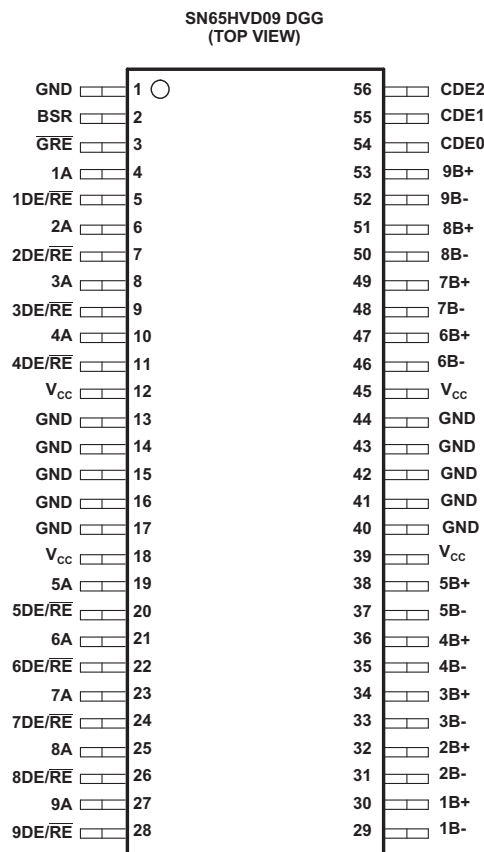

Terminals 13 through 17, and 40 through 44 are connected together to the package lead frame and signal ground.

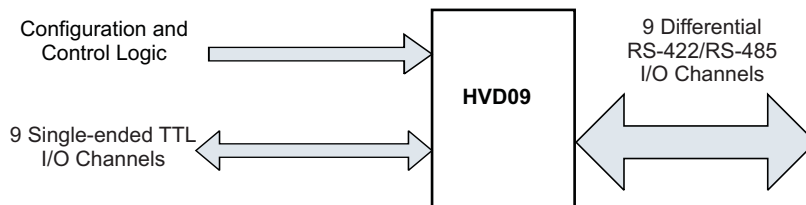

Please be aware that an important notice concerning availability, standard warranty, and use in critical applications of Texas Instruments semiconductor products and disclaimers thereto appears at the end of this data sheet.



These devices have limited built-in ESD protection. The leads should be shorted together or the device placed in conductive foam during storage or handling to prevent electrostatic damage to the MOS gates.

PIN FUNCTIONS

PIN		LOGIC LEVEL	I/O	TERMINATION	DESCRIPTION
NAME	NO.				
1A to 9A	4,6,8,10, 19,21,23, 25,27	TTL	I/O	Pullup	1A to 9A carry data to and from the communication controller.
1B– to 9B–	29,31,33, 35,37,46 , 48,50,52	RS-485	I/O	Pulldown	1B– to 9B– are the inverted data signals of the balanced pair to/from the bus.
1B+ to 9B+	30,32,34, 36,38,47, 49,51,53	RS-485	I/O	Pullup	1B+ to 9B+ are the noninverted data signals of the balanced pair to/from the bus.
BSR	2	TTL	Input	Pullup	BSR is the bit significant response. BSR disables receivers 1 through 8 and enables wired-OR drivers when BSR and DE/RE and CDE1 or CDE2 are high. Channel 9 is placed in a high-impedance state with BSR high.
CDE0	54	TTL	Input	Pulldown	CDE0 is the common driver enable 0. Its input signal enables all drivers when CDE0 and 1DE/RE – 9DE/RE are high.
CDE1	55	TTL	Input	Pulldown	CDE1 is the common driver enable 1. Its input signal enables drivers 1 to 4 when CDE1 is high and BSR is low.
CDE2	56	TTL	Input	Pulldown	CDE2 is the common driver enable 2. When CDE2 is high and BSR is low, drivers 5 to 8 are enabled.
CRE	3	TTL	Input	Pullup	CRE is the common receiver enable. When high, CRE disables receiver channels 5 to 9.
1DE/RE to 9DE/RE	5,7,9,11, 20,22,24, 26,28	TTL	Input	Pullup	1DE/RE–9DE/RE are direction controls that transmit data to the bus when it and CDE0 are high. Data is received from the bus when 1DE/RE–9DE/RE and CRE and BSR are low and CDE1 and CDE2 are low.
GND	1,13,14, 15,16,17, 40,41,42, 43,44	NA	Power	NA	GND is the circuit ground. All GND terminals except terminal 1 are physically tied to the die pad for improved thermal conductivity. ⁽¹⁾
V _{CC}	12,18,39, 45	NA	Power	NA	Supply voltage

(1) Terminal 1 must be connected to signal ground for proper operation.

LOGIC DIAGRAM (POSITIVE LOGIC)

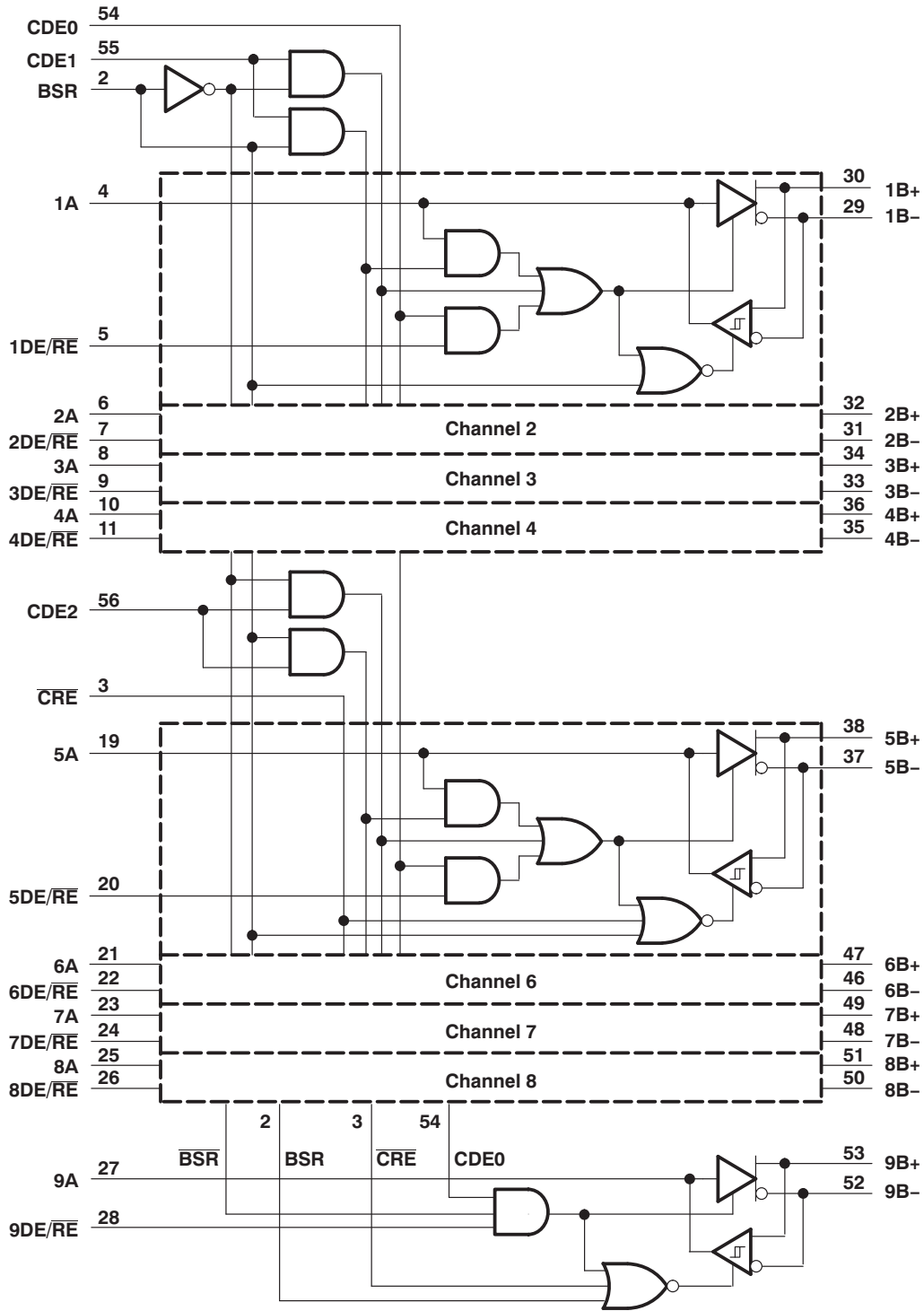

SN65HVD09

SLLS941–DECEMBER 2008

www.ti.com

ABSOLUTE MAXIMUM RATINGS⁽¹⁾

		VALUE	UNIT
V_{CC}	Supply voltage range ⁽²⁾	–0.3 to 6	V
	Bus voltage range	–10 to 15	V
	Data I/O and control (A side) voltage range	–0.3 to $V_{CC} + 0.5$	V
I_O	Receiver output current	±40	mA
Electrostatic discharge	B side and GND, Class 3, A ⁽³⁾	12	kV
	B side and GND, Class 3, B ⁽³⁾	400	V
	All terminals, Class 3, A	4	kV
	All terminals, Class 3, B	400	V
Continuous total power dissipation ⁽⁴⁾		Internally Limited	

- (1) Stresses beyond those listed under *absolute maximum ratings* may cause permanent damage to the device. These are stress ratings only, and functional operation of the device at these or any other conditions beyond those indicated under *recommended operating conditions* is not implied. Exposure to absolute-maximum-rated conditions for extended periods may affect device reliability.
- (2) All voltage values are with respect to the GND terminals.
- (3) This absolute maximum rating is tested in accordance with MIL-PRF-38535, Method 3015.7.
- (4) The maximum operating junction temperature is internally limited. Use the Dissipation Rating Table to operate below this temperature.

DISSIPATION RATINGS

PACKAGE	$T_A \leq 25^\circ\text{C}$	OPERATING FACTOR ⁽¹⁾ ABOVE $T_A = 25^\circ\text{C}$	$T_A = 70^\circ\text{C}$ POWER RATING	$T_A = 85^\circ\text{C}$ POWER RATING
DGG	2500 mW	20 mW/°C	1600 mW	1300 mW

- (1) This is the inverse of the junction-to-ambient thermal resistance when board-mounted and with no air flow.

PACKAGE THERMAL CHARACTERISTICS

			MIN	NOM	MAX	UNIT
θ_{JA}	Junction-to-ambient thermal resistance	DGG, board-mounted, no air flow		50		°C/W
θ_{JC}	Junction-to-case thermal resistance	DGG		27		°C/W
T_{SD}	Thermal shutdown temperature			165		°C

RECOMMENDED OPERATING CONDITIONS

			MIN	NOM	MAX	UNIT
V_{CC}	Supply voltage		4.75	5	5.25	V
V_{IH}	High-level input voltage	Except nB+, nB– ⁽¹⁾	2			V
V_{IL}	Low-level input voltage				0.8	V
V_O , V_I , or V_{IC}	Voltage at any bus terminal (separately or common-mode)	nB+ or nB–	–7		12	V
I_O	Output current	Driver	–60		60	mA
		Receiver	–8		8	mA
T_A	Ambient temperature	SN65HVD09	–40		85	°C

- (1) $n = 1 - 9$

ELECTRICAL CHARACTERISTICS

over operating free-air temperature range (unless otherwise noted)

PARAMETER	TEST CONDITIONS		SN65HVD09			UNIT
			MIN	TYP ⁽¹⁾	MAX	
V _{OD} Driver differential output voltage magnitude	RS-422 load, R _L = 100 Ω	See Figure 1	1	1.6		V
	RS-485 load, R _L = 54 Ω			1.4		
	Pull-Up Pull-Down Load	See Figure 2	1	1.5		
V _{OH} High-level output voltage	A side, I _{OH} = -8 mA, V _{ID} = 200 mV,	See Figure 4	4	4.5		V
	B side,	See Figure 2		3		V
V _{OL} Low-level output voltage	A side, I _{OH} = 8 mA, V _{ID} = -200 mV,	See Figure 4		0.6	0.8	V
	B side,	See Figure 2		1		V
V _{IT+} Receiver positive-going differential input threshold voltages	I _{OH} = -8 mA,	See Figure 4			0.2	V
V _{IT-} Receiver negativegoing differential input threshold voltage	I _{OL} = 8 mA,	See Figure 4	-0.2			V
V _{hys} Receiver input hysteresis (V _{IT+} - V _{IT-})	V _{CC} = 5 V, T _A = 25°C		24	45		mV
I _i Bus input current	V _{IH} = 12 V, V _{CC} = 5 V,	Other input at 0 V			1	mA
	V _{IH} = 12 V, V _{CC} = 0,				1	mA
	V _{IH} = -7 V, V _{CC} = 5 V,		-0.8	-0.4		mA
	V _{IH} = -7 V, V _{CC} = 0,		-0.8	-0.3		mA
I _{IH} High-level input current	nA, BSR, DE/ \overline{RE} , and \overline{CRE} ,	V _{IH} = 2 V	-100			μA
	CDE0, CDE1, and CDE2,	V _{IH} = 2V		100		μA
I _{IL} Low-level input current	nA, BSR, DE/ \overline{RE} , and \overline{CRE} ,	V _{IL} = 0.8 V	-100			μA
	CDE1, CDE1, and CDE2,	V _{IL} = 0.8 V		100		μA
I _{OS} Short circuit output current	nB+ or nB-				±260	mA
I _{OZ} High-impedance-state output current	nA		See I _{IH} and I _{IL}			
	nB+ or nB-		See I _{Ii}			
I _{CC} Supply current	Disabled				10	mA
	All drivers enabled, no load				60	
	All receivers enabled, no load				45	
C _O Output capacitance	nB+ or nB- to GND		18	25		pF
C _{pd} Power dissipation capacitance ⁽²⁾	Receiver		40			pF
	Driver		100			

 (1) All typical values are at V_{CC} = 5 V, T_A = 25°C.

 (2) C_{pd} determines the no-load dynamic supply current consumption, I_S = C_{PD} × V_{CC} × f + I_{CC}

DRIVER SWITCHING CHARACTERISTICS

over recommended operating conditions (unless otherwise noted)

PARAMETER	TEST CONDITIONS	SN65HVD09			UNIT
		MIN	TYP ⁽¹⁾	MAX	
t_{pd} Propagation delay time, t_{PHL} or t_{PLH} (see Figure 2 and Figure 3)		2.5		13.5	ns
$t_{sk(p)}$ Pulse skew, $ t_{PHL} - t_{PLH} $				4	ns
t_f Fall time	S1 to B, See Figure 3		4		ns
t_r Rise time	See Figure 3		8		ns
t_{en} Enable time, control inputs to active output				50	ns
t_{dis} Disable time, control inputs to high-impedance output				100	ns
t_{PHZ} Propagation delay time, high-level to high-impedance output	See Figure 6 and Figure 7		17	100	ns
t_{PLZ} Propagation delay time, low-level to high-impedance output			25	100	ns
t_{PZH} Propagation delay time, high-impedance to high-level output			17	50	ns
t_{PZL} Propagation delay time, high-impedance to low-level output			17	50	ns

 (1) All typical values are at $V_{CC} = 5\text{ V}$, $T_A = 25^\circ\text{C}$.

RECEIVER SWITCHING CHARACTERISTICS

over recommended operating conditions (unless otherwise noted)

PARAMETER	TEST CONDITIONS	SN65HVD09			UNIT
		MIN	TYP ⁽¹⁾	MAX	
t_{pd} Propagation delay time, t_{PHL} or t_{PLH} (see Figure 2 and Figure 3)		8.5		14.5	ns
$t_{sk(lim)}$ Skew limit, maximum t_{pd} – minimum t_{pd} ⁽²⁾				5	ns
$t_{sk(p)}$ Pulse skew, $ t_{PHL} - t_{PLH} $			0.6	4	ns
t_t Transition time (t_r or t_f)	See Figure 5		2		ns
t_{en} Enable time, control inputs to active output				50	ns
t_{dis} Disable time, control inputs to high-impedance output				60	ns
t_{PHZ} Propagation delay time, high-level to high-impedance output	See Figure 8 and Figure 9			60	ns
t_{PLZ} Propagation delay time, low-level to high-impedance output				50	ns
t_{PZH} Propagation delay time, high-impedance to high-level output				50	ns
t_{PZL} Propagation delay time, high-impedance to low-level output				50	ns

 (1) All typical values are at $V_{CC} = 5\text{ V}$, $T_A = 25^\circ\text{C}$.

 (2) This parameter is applicable at one V_{CC} and operating temperature within the recommended operating conditions and to any two devices.

PARAMETER MEASUREMENT INFORMATION

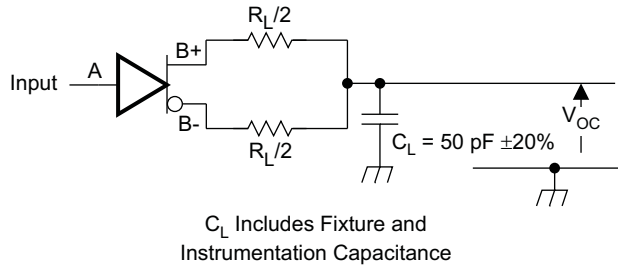
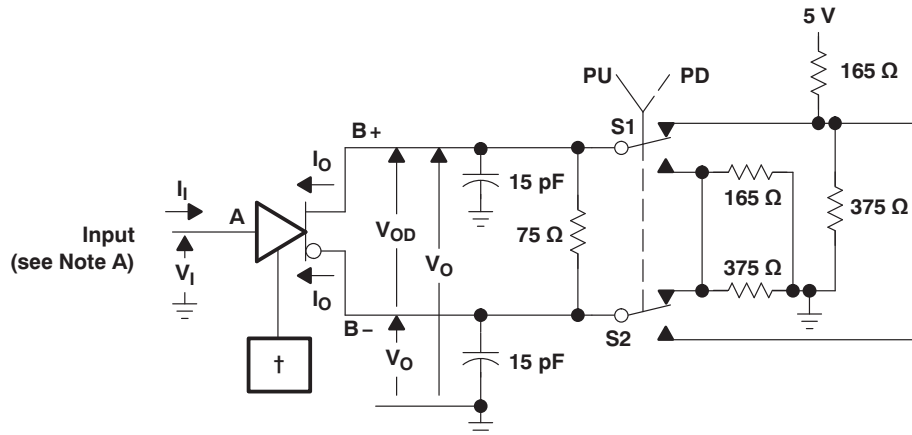

Figure 1. Driver Test Circuit, RS-422 and RS-485 Loading



† CDEO and DE/RE are at 2 V, BSR is at 0.8V, and all others are open.
‡ All nine drivers are enabled, similarly loaded, and switching.

Figure 2. Driver Test Circuit, Pull-Up and Pull-Down Loading[†]

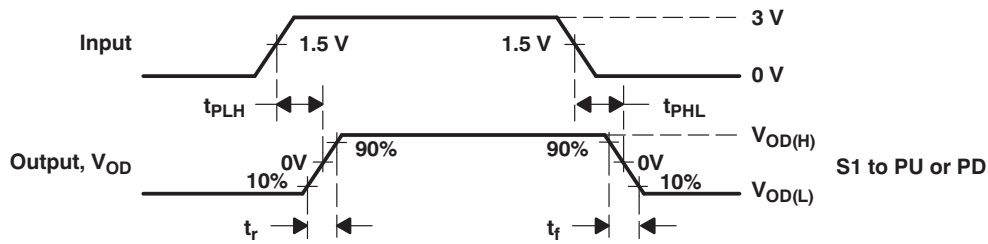
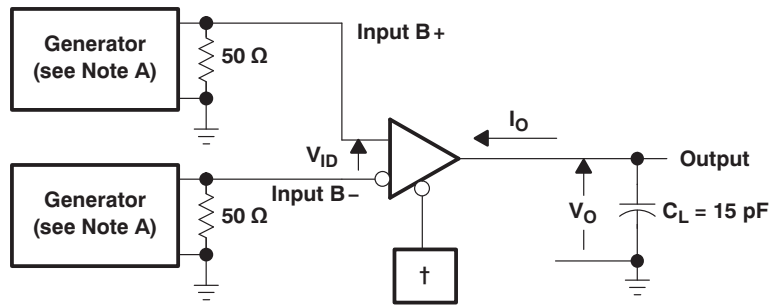

Figure 3. Driver Delay and Transition Time Test Waveforms

PARAMETER MEASUREMENT INFORMATION (continued)



† CDE0, CDE1, CDE2, BSR, CRE, and DE/RE at 0.8 V

‡ All nine receivers are enabled and switching.

Figure 4. Receiver Propagation Delay and Transition Time Test Circuit

- A. All input pulses are supplied by a generator having the following characteristics: $t_r \leq 6$ ns, $t_f \leq 6$ ns, PRR ≤ 1 MHz, duty cycle = 50%, $Z_O = 50 \Omega$.
- B. All resistances are in Ω and $\pm 5\%$, unless otherwise indicated.
- C. All capacitances are in pF and $\pm 10\%$, unless otherwise indicated.
- D. All indicated voltages are ± 10 mV.

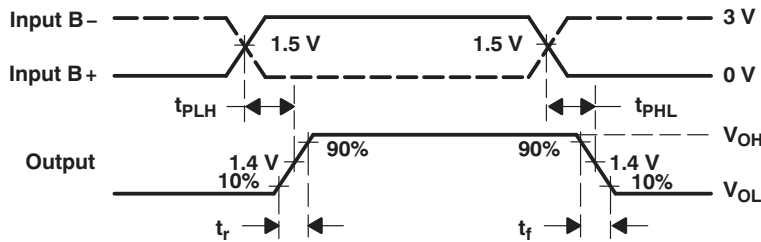
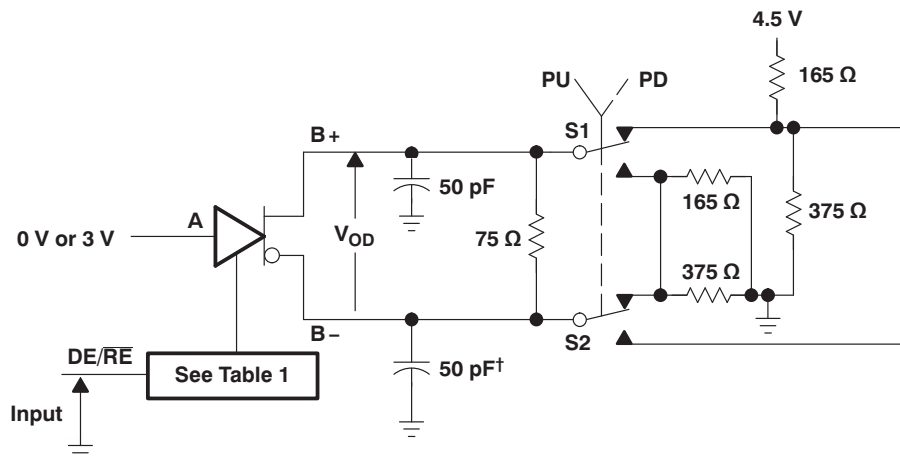

Figure 5. Receiver Delay and Transition Time Waveforms



† Includes probe and jig capacitance in two places.

Figure 6. Driver Enable and Disable Time Test Circuit

Table 1. Enabling for Driver Enable and Disable Time

DRIVER	BSR	CDE0	CDE1	CDE2	$\overline{\text{CRE}}$
1–8	H	H	L	L	X
9	L	H	H	H	H

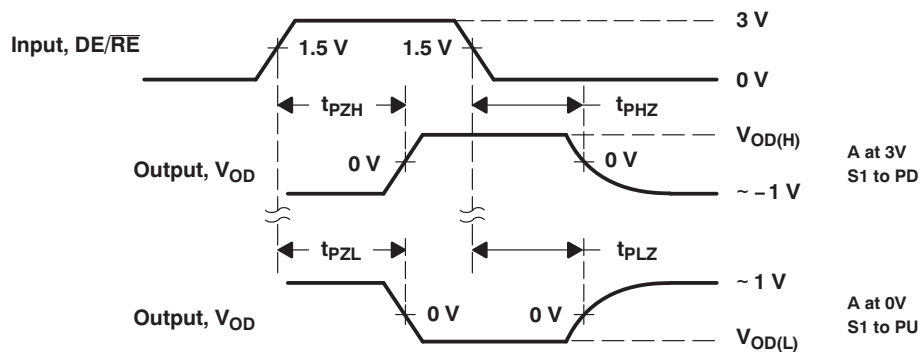
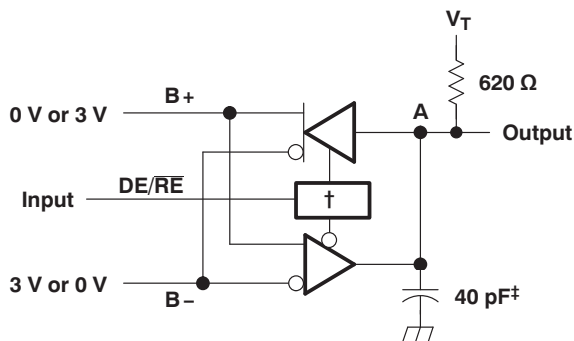

Figure 7. Driver Enable Time Waveforms

- NOTES:
- A. All input pulses are supplied by a generator having the following characteristics: $t_r \leq 6$ ns, $t_f \leq 6$ ns, PRR ≤ 1 MHz, duty cycle = 50%, $Z_0 = 50 \Omega$.
 - B. All resistances are in Ω and $\pm 5\%$, unless otherwise indicated.
 - C. All capacitances are in pF and $\pm 10\%$, unless otherwise indicated.
 - D. All indicated voltages are ± 10 mV.



† CDE0 is high, CDE1, CDE2, BSR, and $\overline{\text{CRE}}$ are low, all others are open.

‡ Includes probe and jig capacitance.

Figure 8. Receiver Enable and Disable Time Test Circuit

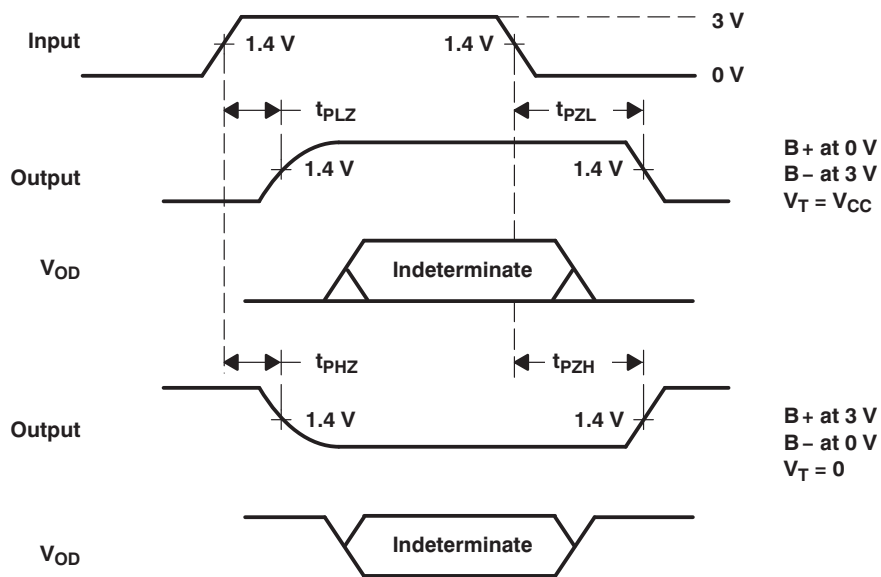
Figure 9. Receiver Enable and Disable Time Waveforms

- NOTES:
- All input pulses are supplied by a generator having the following characteristics: $t_r \leq 6$ ns, $t_f \leq 6$ ns, PRR ≤ 1 MHz, duty cycle = 50%, $Z_O = 50$ Ω .
 - All resistances are in Ω and $\pm 5\%$, unless otherwise indicated.
 - All capacitances are in pF and $\pm 10\%$, unless otherwise indicated.
 - All indicated voltages are ± 10 mV.

TYPICAL CHARACTERISTICS

AVERAGE SUPPLY CURRENT
VS
FREQUENCY

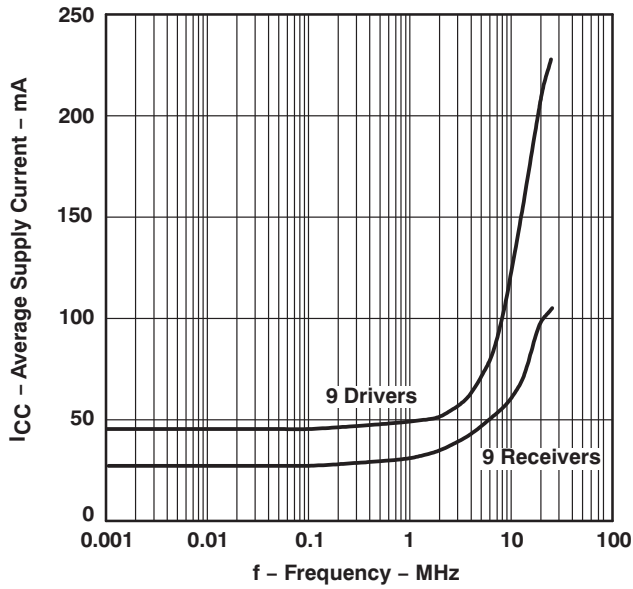

Figure 10.

LOGIC INPUT CURRENT
VS
INPUT VOLTAGE

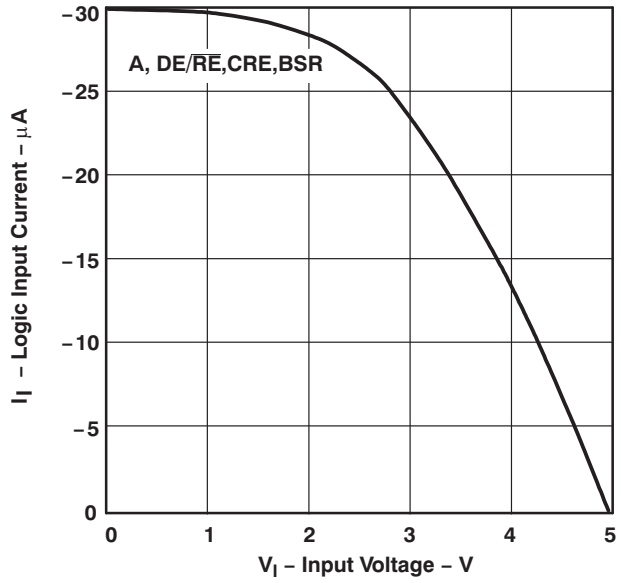

Figure 11.

BUS
INPUT CURRENT
VS
INPUT VOLTAGE

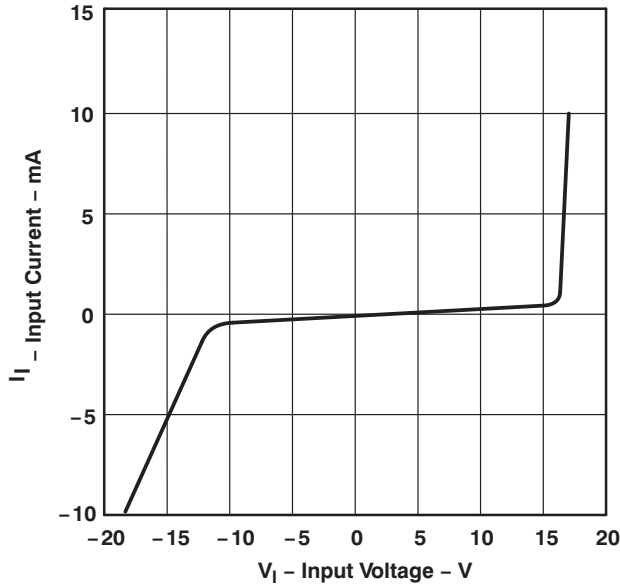

Figure 12.

DRIVER
LOW-LEVEL OUTPUT VOLTAGE
VS
LOW-LEVEL OUTPUT CURRENT

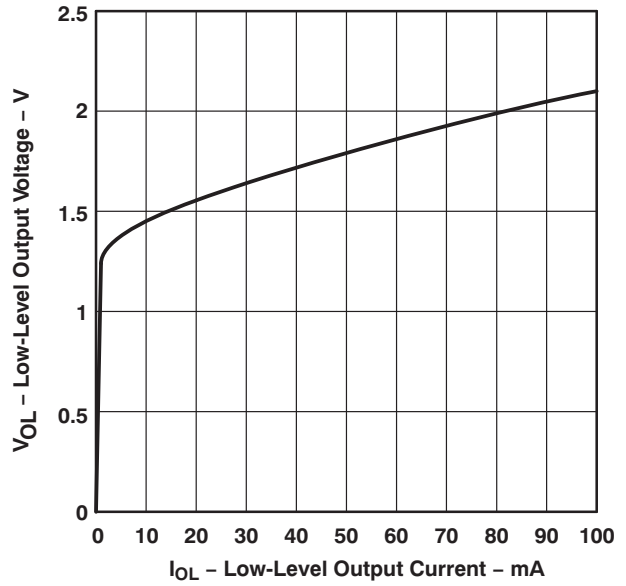

Figure 13.

TYPICAL CHARACTERISTICS (continued)

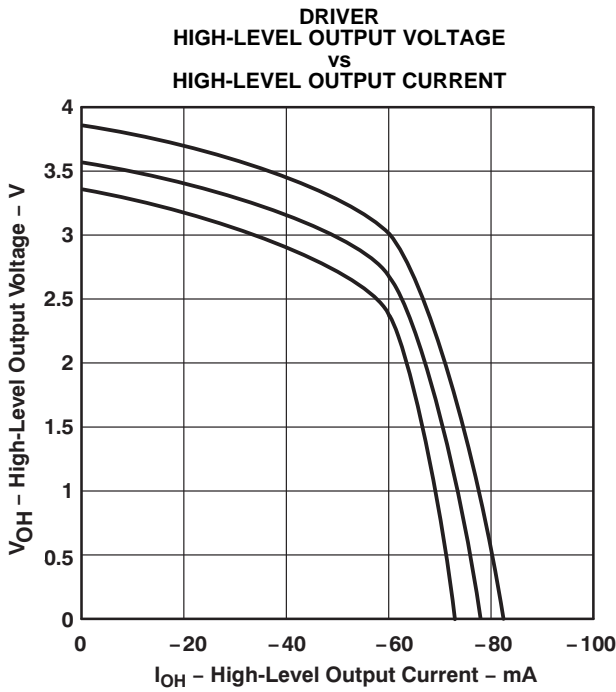

Figure 14.

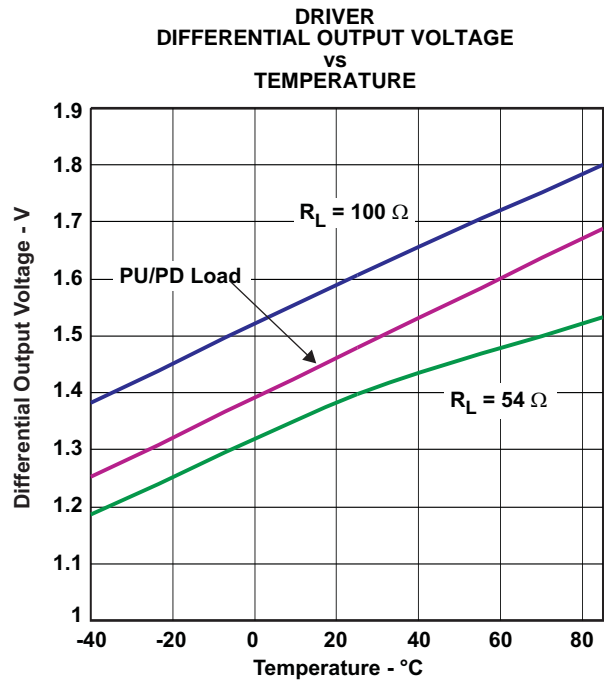

Figure 15.

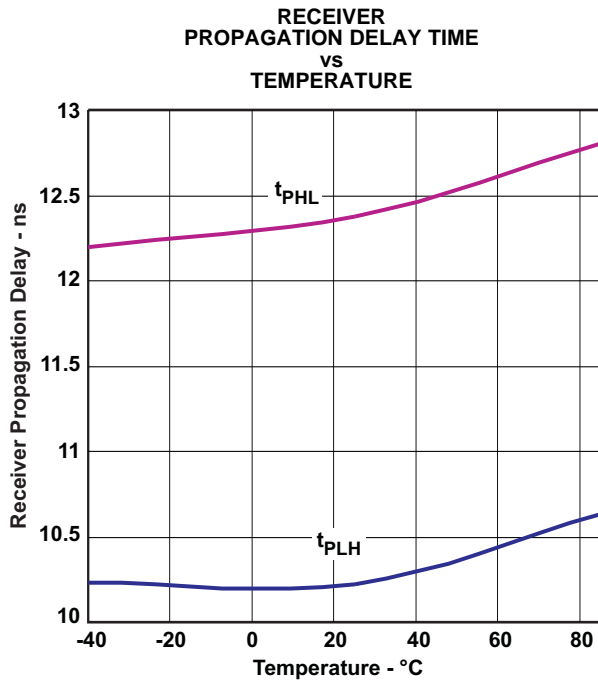

Figure 16.

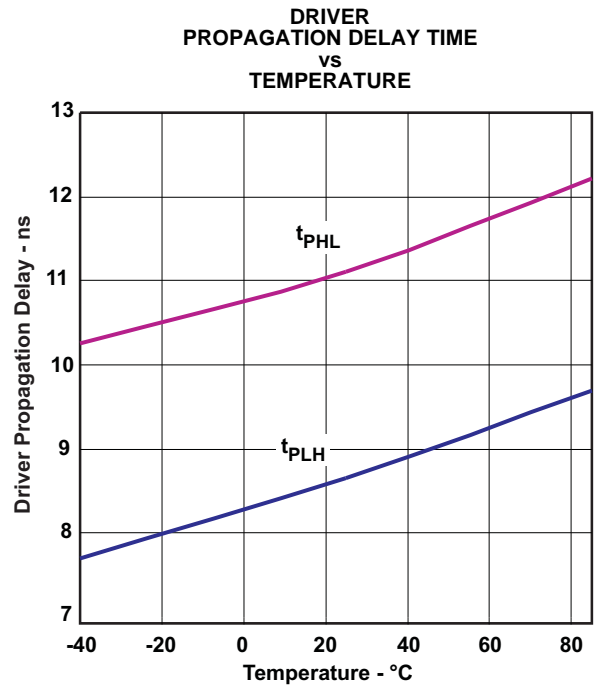

Figure 17.

TYPICAL CHARACTERISTICS (continued)

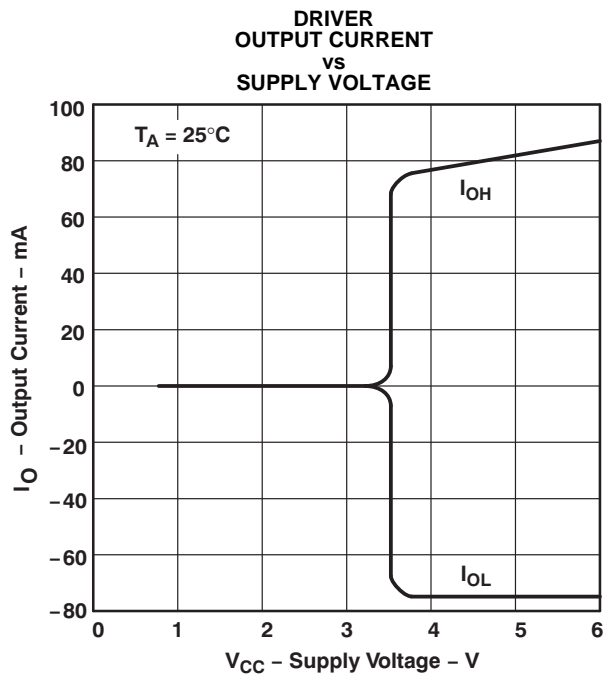
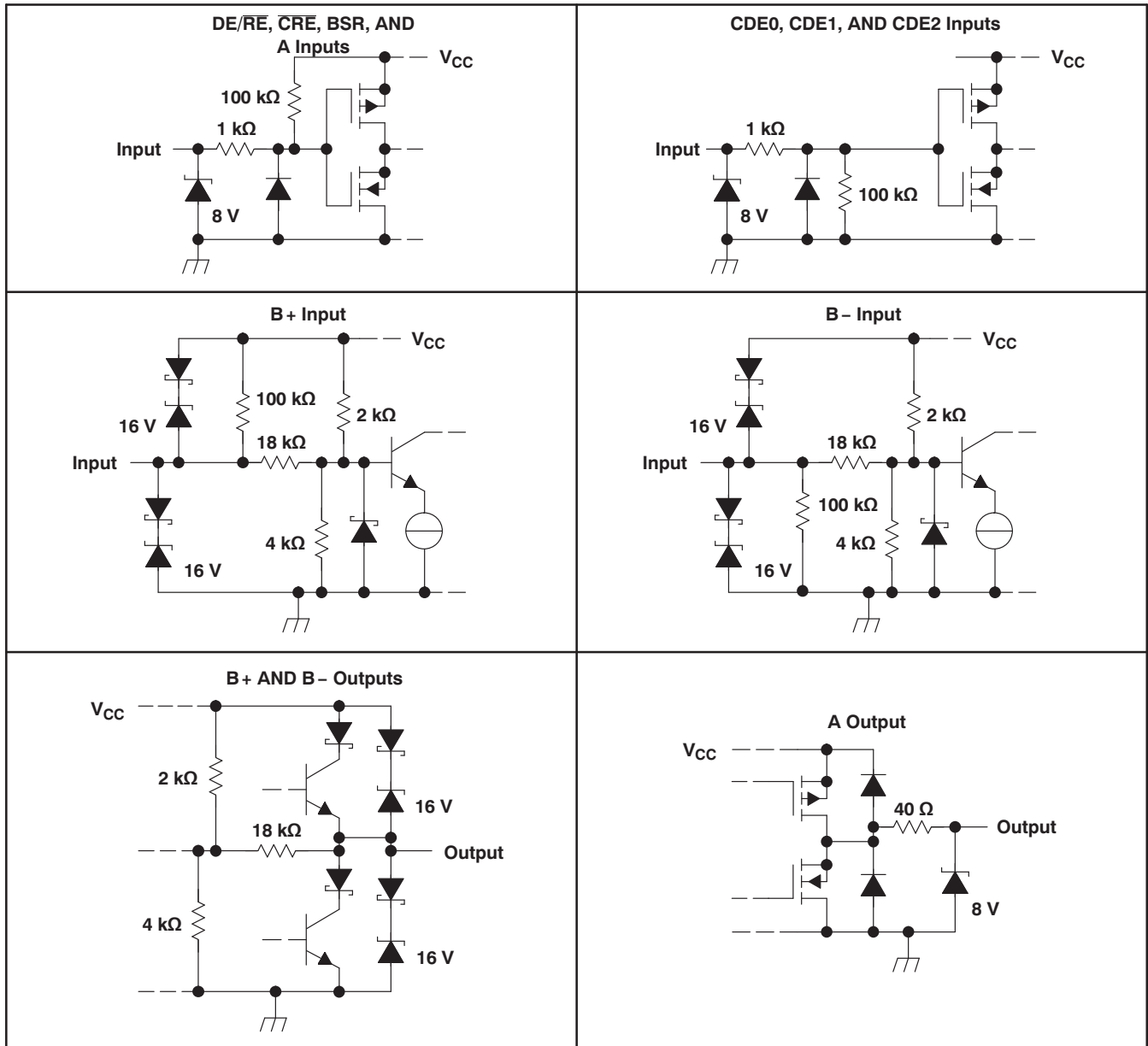

Figure 18.

TYPICAL CHARACTERISTICS (continued)

SCHEMATICS OF INPUTS AND OUTPUTS



APPLICATION INFORMATION

FUNCTION TABLES

RECEIVER

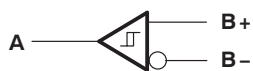

INPUTS		OUTPUT A
B+ ¹	B- ¹	
L	H	L
H	L	H

DRIVER



INPUT A	OUTPUTS	
	B+	B-
L	L	H
H	H	L

TRANSCEIVER

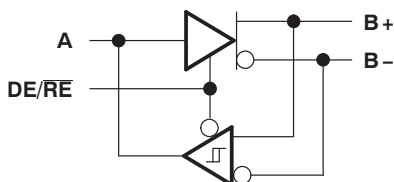

DE/RE	INPUTS			OUTPUTS		
	A	B+ ¹	B- ¹	A	B+	B-
L	-	L	H	L	-	-
L	-	H	L	H	-	-
H	L	-	-	-	L	H
H	H	-	-	-	H	L

DRIVER WITH ENABLE

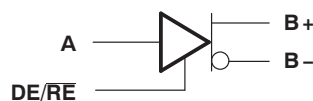

DE/RE	INPUTS		OUTPUTS	
	A	B+	B+	B-
L	L	Z	Z	Z
L	H	Z	Z	Z
H	L	L	H	H
H	H	H	L	L

WIRED-OR DRIVER

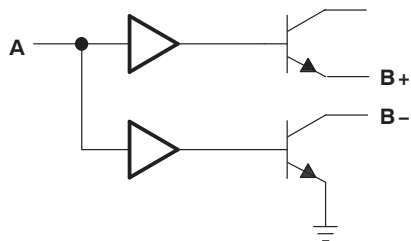

INPUT A	OUTPUTS	
	B+	B-
L	Z	Z
H	H	L

TWO-ENABLE INPUT DRIVER

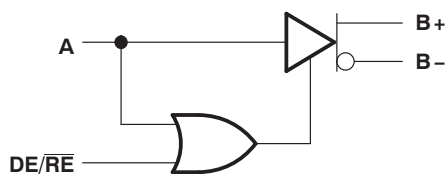

DE/RE	INPUTS		OUTPUTS	
	A	B+	B+	B-
L	L	Z	Z	Z
L	H	H	L	L
H	L	L	H	H
H	H	H	L	L

NOTE: H = high level, L = low level, X = irrelevant, Z = high impedance (off)

- (1) An H in this column represents a voltage of 200 mV or higher than the other bus input. An L represents a voltage of 200 mV or lower than the other bus input. Any voltage less than 200 mV results in an indeterminate receiver output.

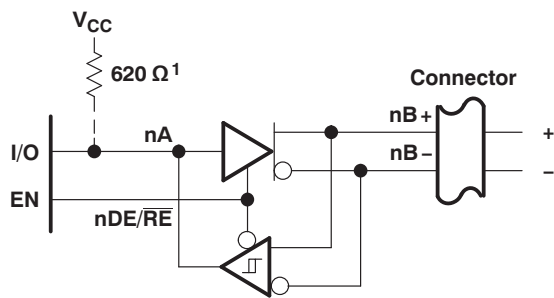

(a) ACTIVE-HIGH BIDIRECTIONAL I/O WITH SEPARATE ENABLE

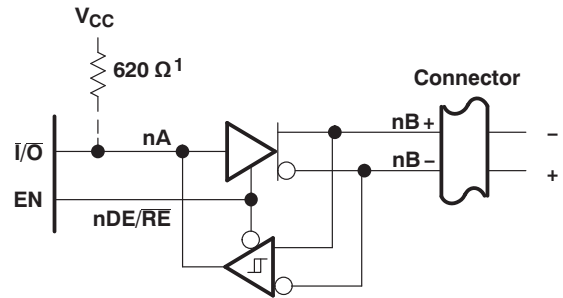

(b) ACTIVE-LOW BIDIRECTIONAL I/O WITH SEPARATE ENABLE

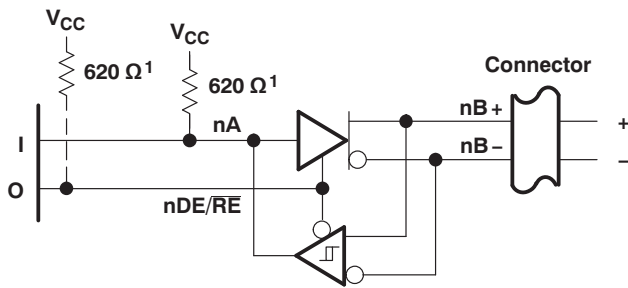

(c) WIRED-OR DRIVER AND ACTIVE-HIGH INPUT

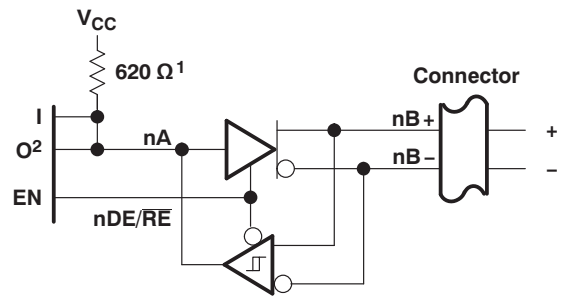

(d) SEPARATE ACTIVE-HIGH INPUT, OUTPUT, AND ENABLE

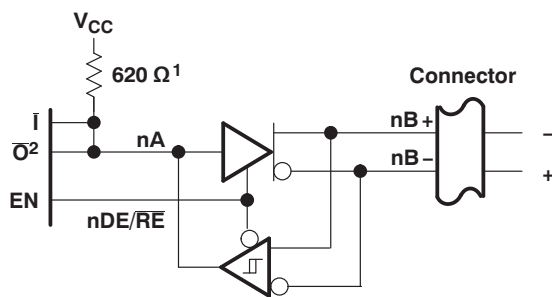

(e) SEPARATE ACTIVE-LOW INPUT AND OUTPUT AND ACTIVE-HIGH ENABLE

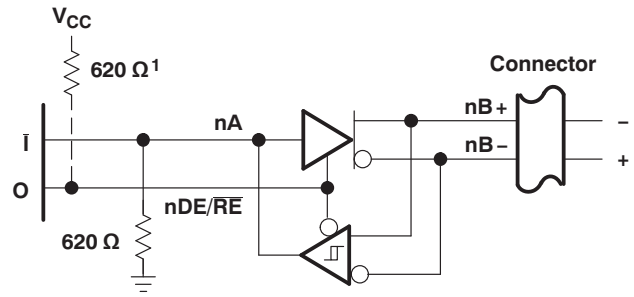

(f) WIRED-OR DRIVER AND ACTIVE-LOW INPUT

1: When 0 is open drain
 2: Must be open-drain or 3-state output

- (1) When 0 is open drain
- (2) Must be open-drain or 3-state output

NOTE: The BSR, $\overline{\text{CRE}}$, A, and $\text{DE}/\overline{\text{RE}}$ inputs have internal pullup resistors. CDE0, CDE1, and CDE2 have internal pulldown resistors.

Figure 19. Typical Transceiver Connections

CHANNEL LOGIC CONFIGURATIONS WITH CONTROL INPUT LOGIC

The following logic diagrams show the positive-logic representation for all combinations of control inputs. The control inputs are from MSB to LSB; the BSR, CDE0, CDE1, CDE2, and CRE bit values are shown below the diagrams. Channel 1 is at the top of the logic diagrams; channel 9 is at the bottom of the logic diagrams.

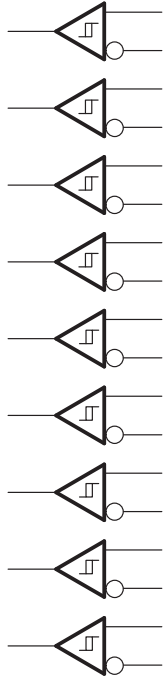

Figure 19. 00000

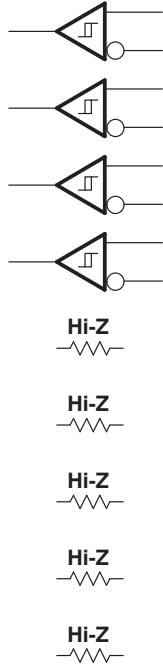

Figure 20. 00001

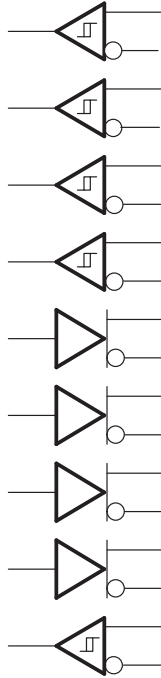

Figure 21. 00010

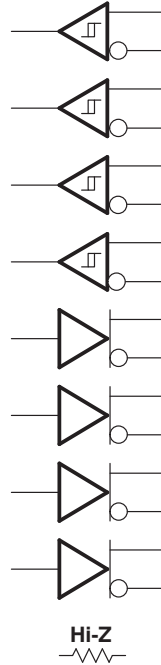

Figure 22. 00011

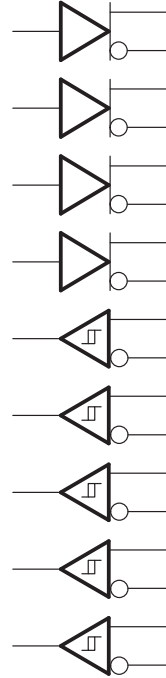

Figure 23. 00100

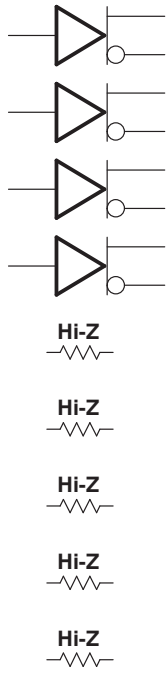

Figure 24. 00101

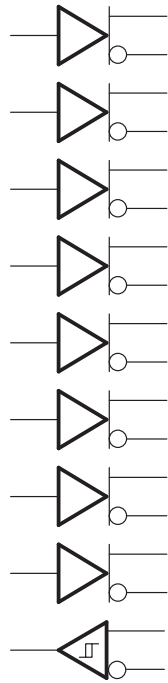

Figure 25. 00110

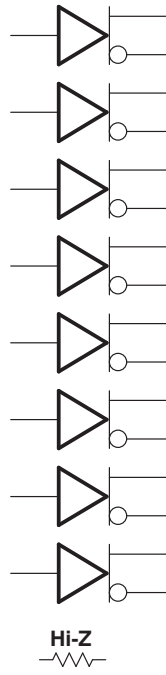

Figure 26. 00111

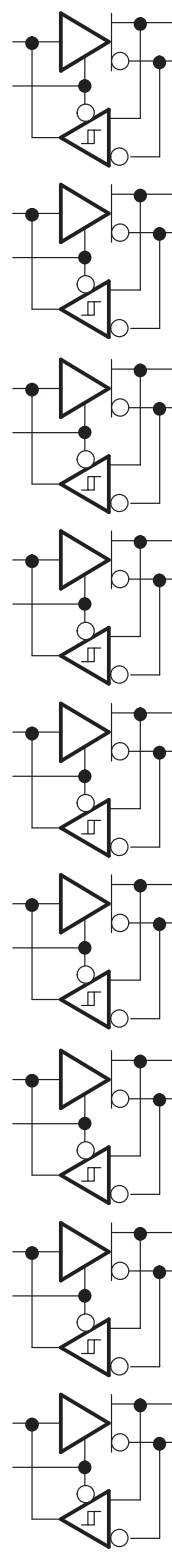

Figure 27. 01000

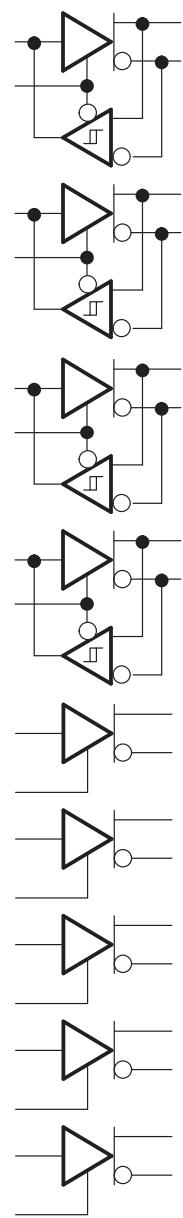

Figure 28. 01001

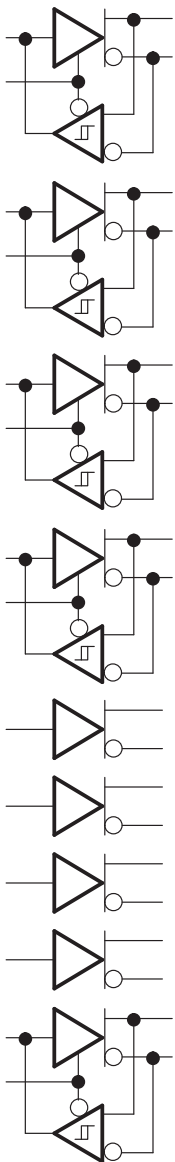

Figure 29. 01010

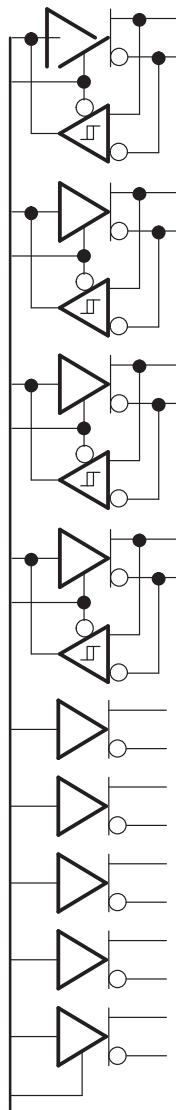

Figure 30. 01011

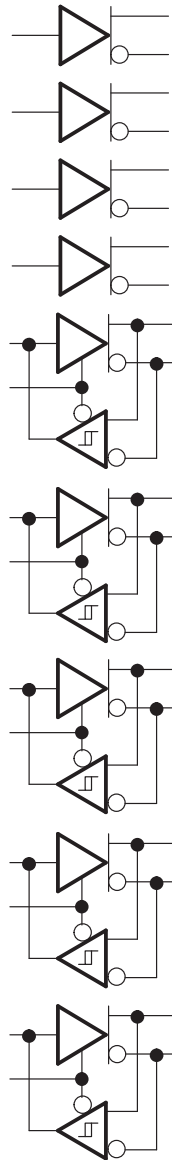

Figure 31. 01100

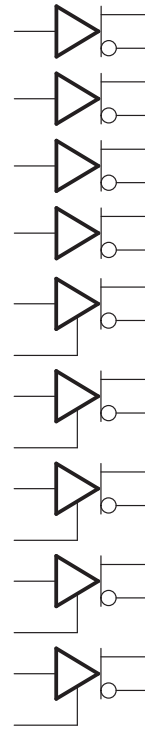

Figure 32. 01101

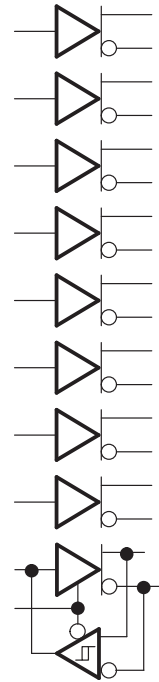

Figure 33. 01110

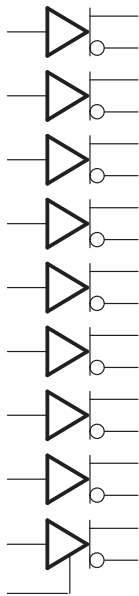

Figure 34. 01111



Figure 35. 10000 and 10001

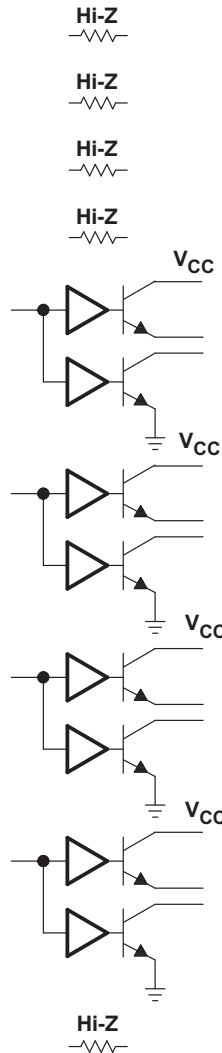

Figure 36. 10010 and 10011

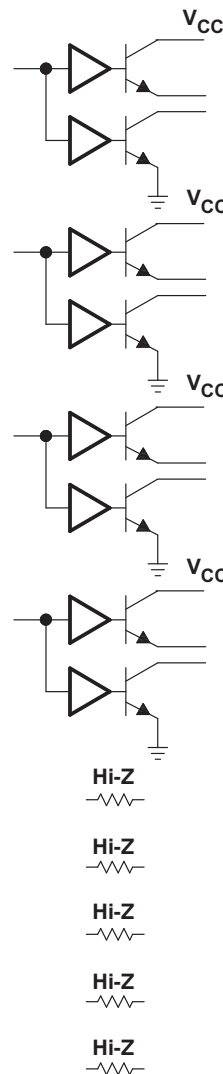

Figure 37. 10100 and 10101

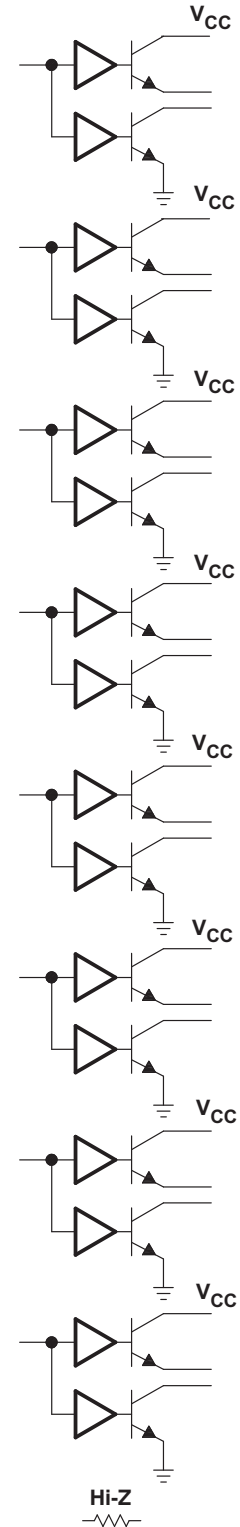

Figure 38. 10110 and 10111

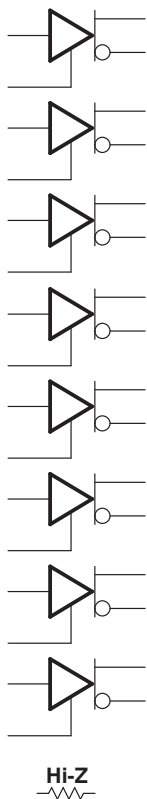

Figure 39. 11000 and 11001

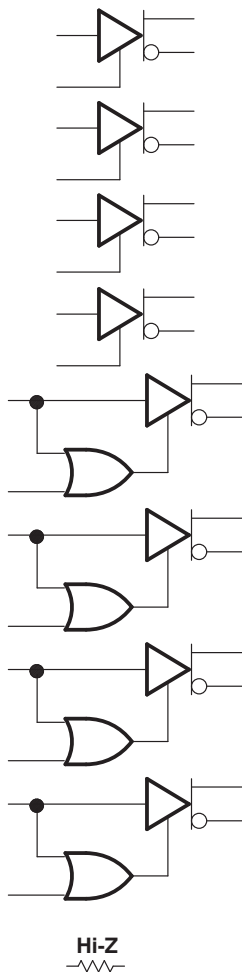

Figure 40. 11010 and 11011

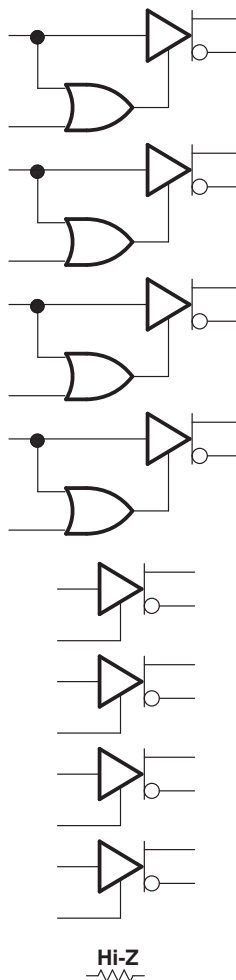

Figure 41. 11100 and 11101

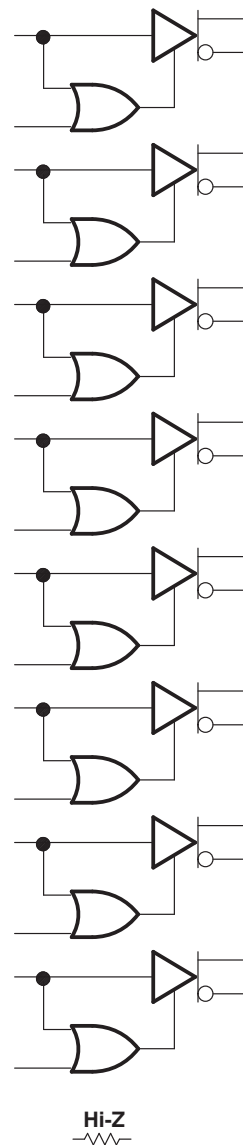

Figure 42. 11110 and 11111

TAPE AND REEL INFORMATION

QUADRANT ASSIGNMENTS FOR PIN 1 ORIENTATION IN TAPE

*All dimensions are nominal

Device	Package Type	Package Drawing	Pins	SPQ	Reel Diameter (mm)	Reel Width W1 (mm)	A0 (mm)	B0 (mm)	K0 (mm)	P1 (mm)	W (mm)	Pin1 Quadrant
SN65HVD09DGGR	TSSOP	DGG	56	2000	330.0	24.4	8.6	15.6	1.8	12.0	24.0	Q1

TAPE AND REEL BOX DIMENSIONS



*All dimensions are nominal

Device	Package Type	Package Drawing	Pins	SPQ	Length (mm)	Width (mm)	Height (mm)
SN65HVD09DGGR	TSSOP	DGG	56	2000	367.0	367.0	45.0

DGG0056A



PACKAGE OUTLINE

TSSOP - 1.2 mm max height

SMALL OUTLINE PACKAGE

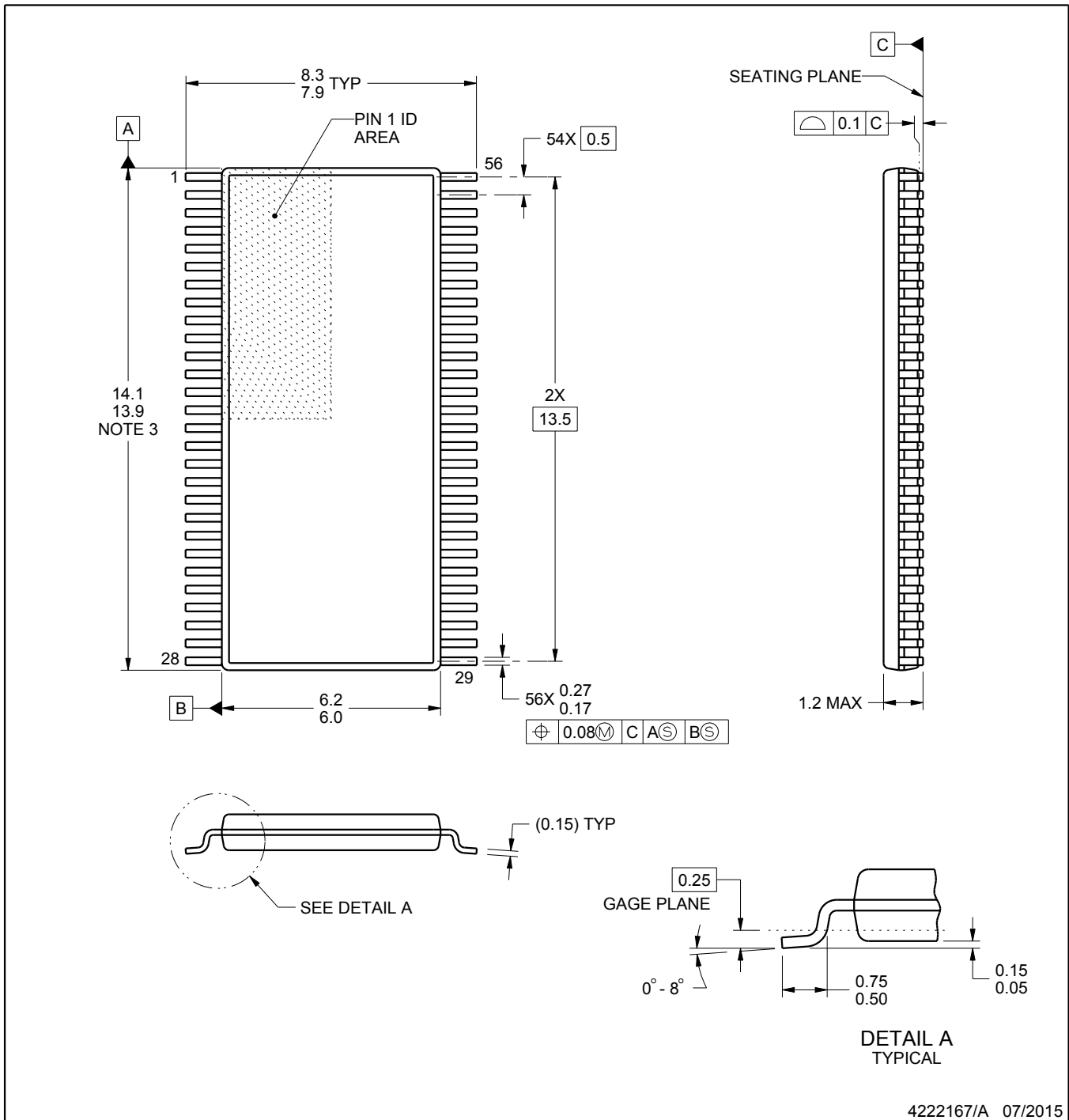

NOTES:

1. All linear dimensions are in millimeters. Any dimensions in parenthesis are for reference only. Dimensioning and tolerancing per ASME Y14.5M.
2. This drawing is subject to change without notice.
3. This dimension does not include mold flash, protrusions, or gate burrs. Mold flash, protrusions, or gate burrs shall not exceed 0.15 mm per side.
4. Reference JEDEC registration MO-153.

EXAMPLE BOARD LAYOUT

DGG0056A

TSSOP - 1.2 mm max height

SMALL OUTLINE PACKAGE

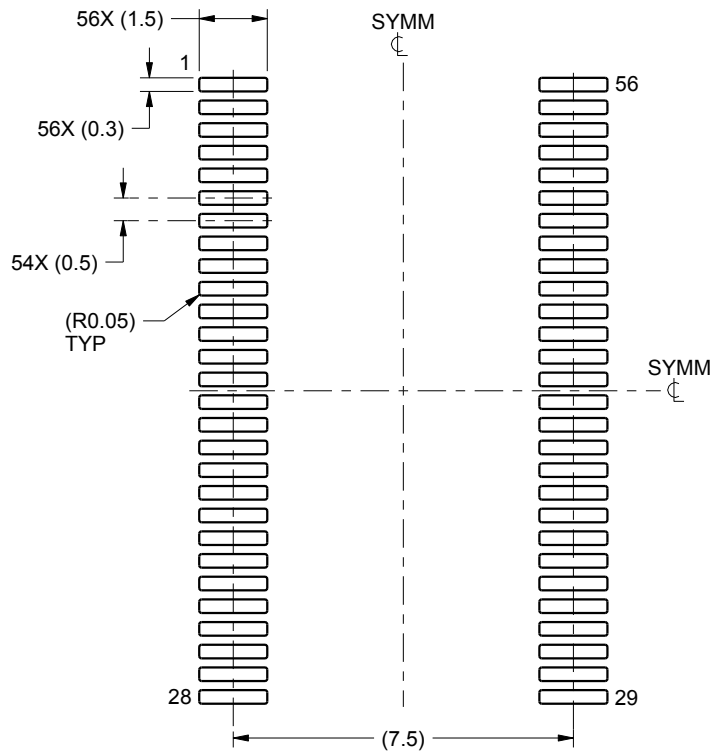

LAND PATTERN EXAMPLE
SCALE:6X

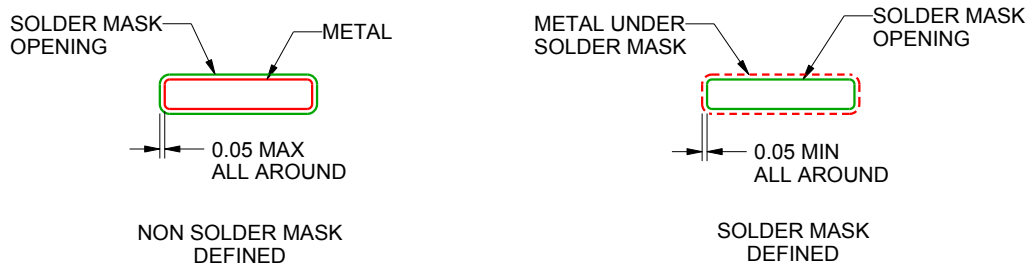

SOLDER MASK DETAILS

4222167/A 07/2015

NOTES: (continued)

- 5. Publication IPC-7351 may have alternate designs.
- 6. Solder mask tolerances between and around signal pads can vary based on board fabrication site.

EXAMPLE STENCIL DESIGN

DGG0056A

TSSOP - 1.2 mm max height

SMALL OUTLINE PACKAGE

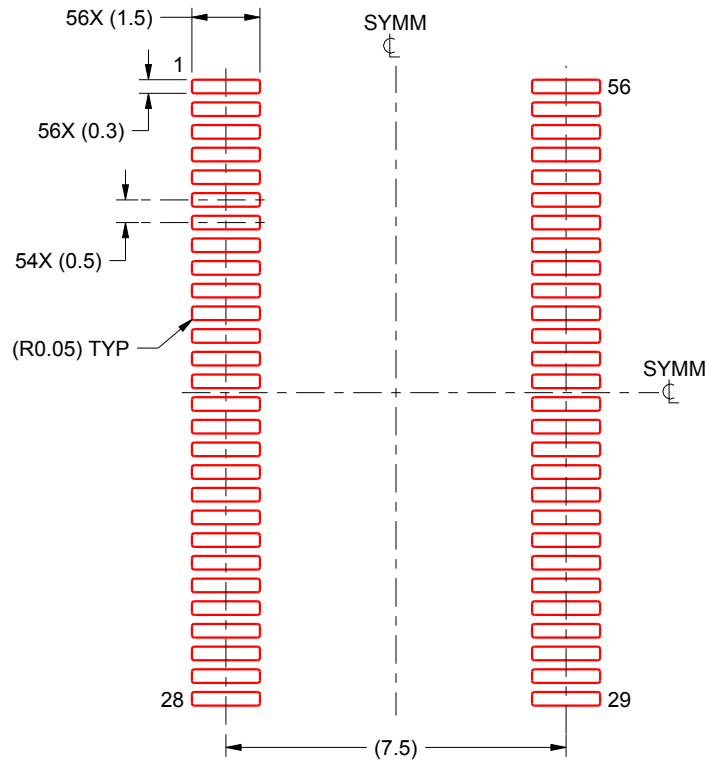

SOLDER PASTE EXAMPLE
BASED ON 0.125 mm THICK STENCIL
SCALE:6X

4222167/A 07/2015

NOTES: (continued)

7. Laser cutting apertures with trapezoidal walls and rounded corners may offer better paste release. IPC-7525 may have alternate design recommendations.
8. Board assembly site may have different recommendations for stencil design.

IMPORTANT NOTICE AND DISCLAIMER

TI PROVIDES TECHNICAL AND RELIABILITY DATA (INCLUDING DATA SHEETS), DESIGN RESOURCES (INCLUDING REFERENCE DESIGNS), APPLICATION OR OTHER DESIGN ADVICE, WEB TOOLS, SAFETY INFORMATION, AND OTHER RESOURCES "AS IS" AND WITH ALL FAULTS, AND DISCLAIMS ALL WARRANTIES, EXPRESS AND IMPLIED, INCLUDING WITHOUT LIMITATION ANY IMPLIED WARRANTIES OF MERCHANTABILITY, FITNESS FOR A PARTICULAR PURPOSE OR NON-INFRINGEMENT OF THIRD PARTY INTELLECTUAL PROPERTY RIGHTS.

These resources are intended for skilled developers designing with TI products. You are solely responsible for (1) selecting the appropriate TI products for your application, (2) designing, validating and testing your application, and (3) ensuring your application meets applicable standards, and any other safety, security, regulatory or other requirements.

These resources are subject to change without notice. TI grants you permission to use these resources only for development of an application that uses the TI products described in the resource. Other reproduction and display of these resources is prohibited. No license is granted to any other TI intellectual property right or to any third party intellectual property right. TI disclaims responsibility for, and you will fully indemnify TI and its representatives against, any claims, damages, costs, losses, and liabilities arising out of your use of these resources.



TI's products are provided subject to [TI's Terms of Sale](#) or other applicable terms available either on [ti.com](https://www.ti.com) or provided in conjunction with such TI products. TI's provision of these resources does not expand or otherwise alter TI's applicable warranties or warranty disclaimers for TI products.

TI objects to and rejects any additional or different terms you may have proposed.

Mailing Address: Texas Instruments, Post Office Box 655303, Dallas, Texas 75265
Copyright © 2024, Texas Instruments Incorporated

Looking for pricing, stock, or lifecycle information?

Click below to explore more details on WIN SOURCE:

-  [View NLV32T-3R9J-EFD on WIN SOURCE](#)
-  [TDK Corporation Information](#)

Optimize Your Supply Chain with WIN SOURCE Solutions

-  Global Sourcing Solution
-  Obsolete Management
-  Cost Control Management
-  Shortage Management
-  Alternative Solution
-  Excess Inventory Management