



**THE DATASHEET OF
RP08-11015SAW**



Features

- 4:1 wide input voltage range
- 1.6kVDC isolation
- UL/IEC/EN60950-1, EN50155 certified
- Efficiency up to 88%
- Protected outputs
- High input voltage range (110VDC)

Regulated Converter



RP08-AW

8 Watt
DIP24/SMD
 Single and Dual
 Output



Description

The RP08-AW series wide range input DC/DC converters are certified to UL60950-1 and cUL 60950-1. This makes them ideal for all telecom and industrial applications where approved safety standards are required. The 24V and 110VDC input versions have been especially designed for railway applications. The DIP24 package is available in both pinned and SMD case styles and meets military standards for thermal shock and vibration tolerance.

Selection Guide

Part Number	Input Voltage Range [VDC]	Output Voltage [VDC]	Output Current [mA]	Input ⁽¹⁾ Current [mA]	Efficiency ⁽¹⁾ typ. [%]	Max. Capacitive Load ⁽²⁾ [µF]
RP08-243.3SAW ⁽³⁾	9-36	3.3	2400	388	85	1330
RP08-2405SAW ⁽³⁾	9-36	5	1600	383	87	1330
RP08-2412SAW ⁽³⁾	9-36	12	666	387	86	288
RP08-2415SAW ⁽³⁾	9-36	15	533	387	86	200
RP08-483.3SAW ⁽³⁾	18-75	3.3	2400	194	85	1330
RP08-4805SAW ⁽³⁾	18-75	5	1600	192	87	1330
RP08-4812SAW ⁽³⁾	18-75	12	666	191	87	288
RP08-4815SAW ⁽³⁾	18-75	15	533	189	88	200
RP08-1103.3SAW ⁽³⁾	43-160	3.3	2400	86	84	1330
RP08-11005SAW ⁽³⁾	43-160	5	1600	86	85	1330
RP08-11012SAW ⁽³⁾	43-160	12	666	84	86	288
RP08-11015SAW ⁽³⁾	43-160	15	533	85	86	200
RP08-2405DAW ⁽³⁾	9-36	±5	±800	397	84	±900
RP08-2412DAW ⁽³⁾	9-36	±12	±333	387	86	±133
RP08-2415DAW ⁽³⁾	9-36	±15	±267	388	86	±90
RP08-4805DAW ⁽³⁾	18-75	±5	±800	198	84	±900
RP08-4812DAW ⁽³⁾	18-75	±12	±333	191	87	±133
RP08-4815DAW ⁽³⁾	18-75	±15	±267	192	87	±90
RP08-11005DAW ⁽³⁾	43-160	±5	±800	89	82	±900
RP08-11012DAW ⁽³⁾	43-160	±12	±333	85	85	±133
RP08-11015DAW ⁽³⁾	43-160	±15	±267	86	85	±90

Notes:

- Note1: Maximum values at nominal input voltage and full load
- Note2: Max. Cap load is tested at minimum Input and constant resistive load

Model Numbering

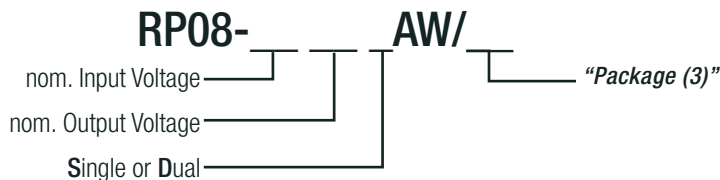

Notes:

- Note3: no suffix for standard DIP24 package
 add suffix "/SMD" for SMD package

Ordering Examples

- RP08-4805SAW/SMD = 48V Input, 5V Output, Single, SMD Package
- RP08-2405DAW = 24V Input, 5V Output, Dual, DIP24 Package

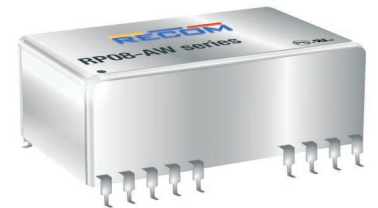

UL60950-1 certified
 IEC/EN60950-1 certified
 EN50155 certified
 EN50121-3-2 compliant
 EN55032 compliant



https://www.recom-power.com/pdf/Powerline_DC-DC/RSPxxx-168.pdf

Specifications (measured @ Ta= 25°C, nom. Vin, full load and after warm-up unless otherwise stated)

BASIC CHARACTERISTICS

Parameter	Condition		Min.	Typ.	Max.
Input Filter			Pi-Type		
Input Voltage Range	nom. Vin = 24VDC nom. Vin = 48VDC nom. Vin = 110VDC		9VDC 18VDC 43VDC	24VDC 48VDC 110VDC	36VDC 75VDC 160VDC
Input Surge Voltage	100ms max.	nom. Vin = 24VDC nom. Vin = 48VDC nom. Vin = 110VDC			50VDC 100VDC 170VDC
Under Voltage Lockout (UVLO)	nom. Vin = 24VDC	DC-DC ON DC-DC OFF		8VDC	9VDC
	nom. Vin = 48VDC	DC-DC ON DC-DC OFF		16VDC	18VDC
	nom. Vin = 110VDC	DC-DC ON DC-DC OFF		40VDC	43VDC
Input Reflected Ripple Current				20mA _{p-p}	
Start-up time	Power up ON/OFF CTRL			450ms 5ms	
Operating Frequency Range			270kHz	300kHz	330kHz
Minimum Load			0%		
ON/OFF CTRL ⁽⁴⁾	Positive Logic	DC-DC ON DC-DC OFF	Open or 3.0VDC < V _{CTRL} < 12VDC Short or 0VDC < V _{CTRL} < 1.2VDC		
Input Current of CTRL pin	DC-DC ON		-0.5mA		+0.5mA
Standby Current	DC-DC OFF			2.5mA	
Ripple and Noise	20MHz BW	nom. Vin = 24VDC, 48VDC nom. Vin = 110VDC		50mV _{p-p} 75mV _{p-p}	

Notes:

Note4: The ON/OFF control pin voltage is referenced to -Vin pin

RP08-2405SAW

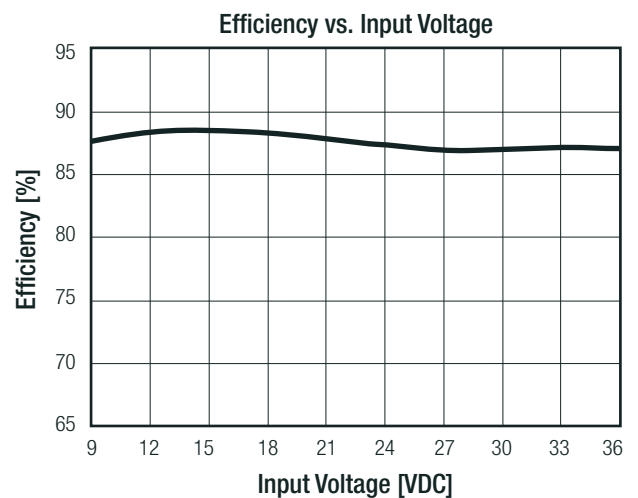
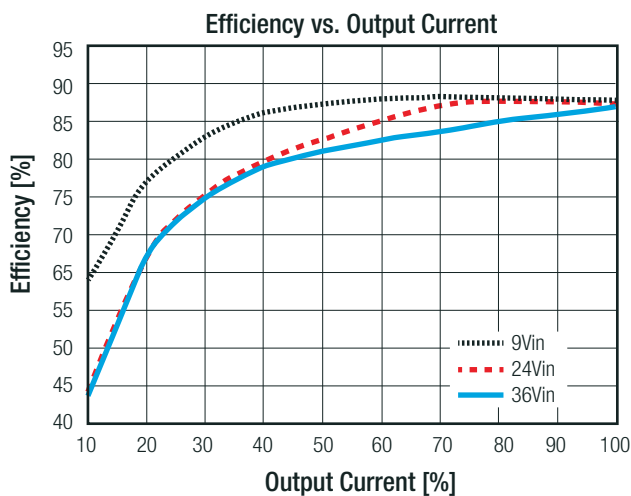

continued on next page

Specifications (measured @ Ta= 25°C, nom. Vin, full load and after warm-up unless otherwise stated)

RP08-4805SAW

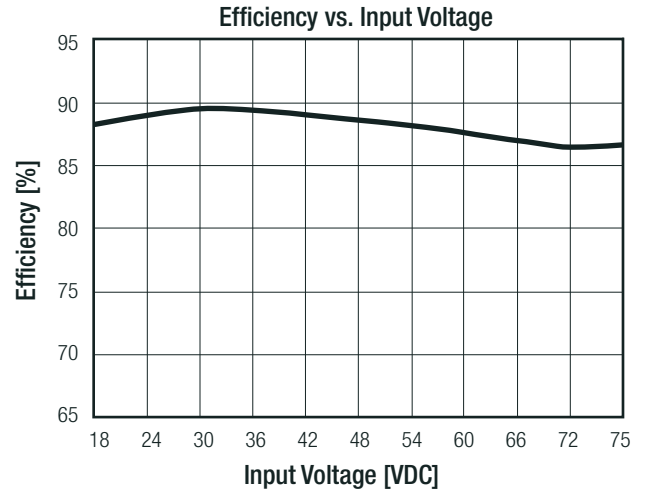
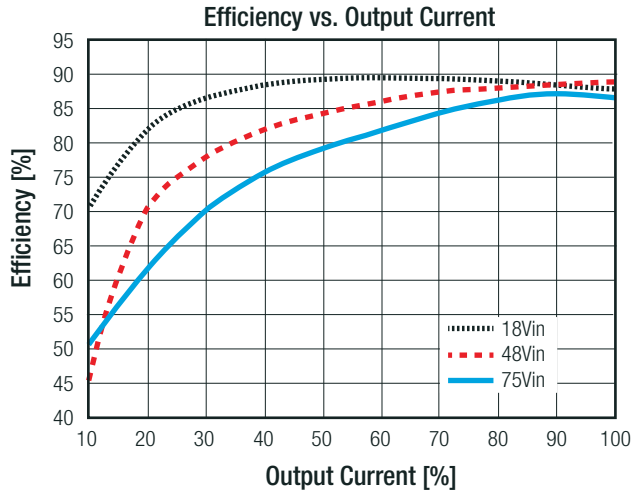

RP08-11005SAW

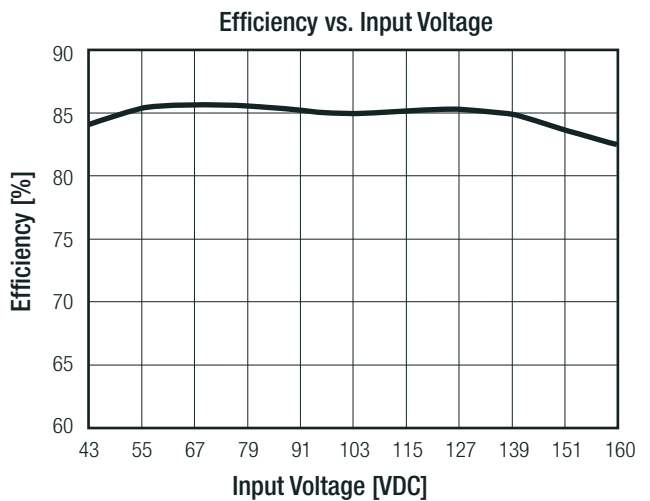
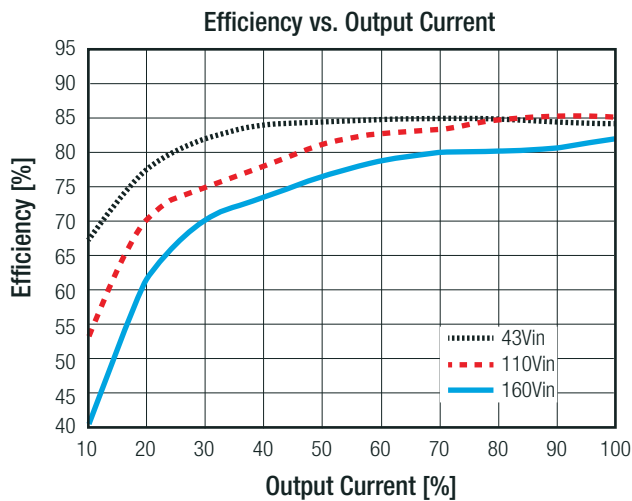

REGULATIONS

Parameter	Condition			Value
Output Accuracy				±1.0%
Line Regulation	low line to high line, full load			±0.2%
Load Regulation	0% to 100% load	DIP24	Single Dual	±0.5% ±1.0%
		SMD	Single, Dual	±1.0%
	10% to 90% load	DIP24	Single Dual	±0.3% ±0.8%
		SMD	Single, Dual	±0.8%
Cross Regulation	asymmetrical 25%<->100% load			±5.0%
Transient Response Recovery Time	25% load step change			250µs typ.

Specifications (measured @ Ta= 25°C, nom. Vin, full load and after warm-up unless otherwise stated)

PROTECTIONS			
Parameter	Condition		Value
Short Circuit Protection (SCP)			continuous, automatic recovery
Over Voltage Protection (OVP)	Single Output	3.3Vout	3.9VDC typ.
		5Vout	6.2VDC typ.
		12Vout	15VDC typ.
		15Vout	18VDC typ.
Over Load Protection (OLP)	% of Iout rated		150% typ.
Isolation Voltage ⁽⁶⁾	DIP24	I/P to O/P, I/P (O/P) to case	1.6kVDC/1 minute
	SMD	I/P to O/P I/P (O/P) to case	1.6kVDC/1 minute 1.0kVDC/1 minute
Isolation Resistance	Viso= 500VDC		1GΩ min.
Isolation Capacitance			1500pF max.
Insulation Grade			functional
Notes: Note5: For repeat Hi-Pot testing, reduce the time and/or the test voltage Note6: This power module is not internally fused. An input line fuse must always be used Recom suggests: 24Vin=T2A; 48Vin=T1A; 110Vin=T0.5A slow blow			

ENVIRONMENTAL			
Parameter	Condition		Value
Operating Temperature Range ⁽⁷⁾	without derating		-40°C to +85°C
	with derating		-40°C to +105°C
Maximum Case Temperature			+105°C
Temperature Coefficient			±0.02%/K max.
Thermal Impedance	@ natural convection 0.1m/s		20K/W
Operating Altitude			4000m
Operating Humidity	non-condensing		5% - 95% RH
Pollution Degree			PD2
Shock			according to MIL-STD-810F
Thermal Shock			according to MIL-STD-810F
Vibration			according to MIL-STD-810F
Fire protection on railway vehicles			according to EN45545-2:2013 standard
MTBF	MIL-HDBK-217F, G.B.		2832 x 10 ³ hours
	Bellcore-TR-NWT-000332 ⁽⁸⁾		2350 x 10 ³ hours

Derating Graph ⁽⁹⁾

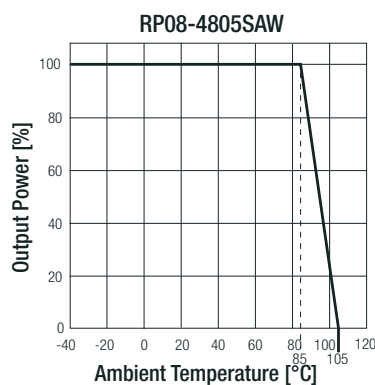

Notes:

- Note7: Converter can meet the railway T2 and TX temperature requirement
- Note8: BELLCORE TR-NWT-000332. Case 1: 50% Stress, Temperature at 40°C (Ground Benign and controlled environment)
MIL-HDBK-217F, G.B., Notice 2, full load, 25°C, Ground Benign
- Note9: Derating graphs are valid only for the shown part numbers. If you need detailed derating-information about a part-number not shown here please contact RECOM Techsupport for detailed information

Specifications (measured @ Ta= 25°C, nom. Vin, full load and after warm-up unless otherwise stated)

SAFETY AND CERTIFICATIONS		
Certificate Type (Safety)	Report / File Number	Standard
Information Technology Equipment, General Requirements for Safety	E196683	UL60950-1, 2nd Edition, 2014 C22.2 No. 60950-1-07, 2nd Edition, 2014
Information Technology Equipment, General Requirements for Safety (LVD)	TW1708010-001	IEC60950-1:2005, 2nd Edition + A2:2013 EN60950-1:2006 + A2:2013
EAC	RU-AT.49.09571	TP TC 004/2011
RoHS 2		RoHS-2011/65/EU + AM-2015/863
Railways	Condition	Standard / Criterion
Railway Applications - Electrical Equipment used on rolling stock	15A100701E-C	EN50155:2007
Environmental testing Part 2-1: Tests – Test A: Cold	Temperature: -25°C, Dwell Time: 2 hours	EN60068-2-1:2007
Environmental testing Part 2-2: Tests – Test B: Dry heat	Temperature: +70°C, Dwell Time: 6 hours	EN60068-2-2:2007
Environmental testing Part 2-30: Tests - Test Db: Damp heat, cyclic (12 h + 12 h cycle)	Temperature: +25 to +55°C Humidity: 90% to 100%RH Test Duration: 24 hours/cycle, 2 cycles	EN60068-2-30:2005
Railway applications - Fire protection on railway vehicles Part2: Requirements for fire behaviour of materials and components		EN45545-2:2013
Fire hazard testing Part 2-11: Glowing/hot-wire based test methods – Glow-wire flammability test method for end-products	glow-wire test	EN60695-2-11
Fire hazard testing Part 11-10: Test flames – 50 W horizontal and vertical flame test methods	vertical flame test	EN60695-11-10
EMC Compliance Railway	Condition	Standard / Criterion
Railway applications - Electromagnetic compatibility		EN50121-3-2:2006
Industrial, scientific and medical equipment – Radio frequency disturbance characteristics – Limits and methods of measurement		EN55011
ESD Electrostatic discharge immunity test	Air ±2, 4,8kV, Contact ±2, 4, 6kV	EN61000-4-2, Criteria A
Radiated, radio-frequency, electromagnetic field immunity test	20V/m (80-1000MHz) 10V/m (1400-2100MHz) 5V/m (2100-2500MHz)	EN61000-4-3, Criteria A
Fast Transient and Burst Immunity	DC Power Port: ±2kV	EN61000-4-4, Criteria A
Surge Immunity	DC Power Port: Line-Line ±0.5, 1kV DC Power Port: Line-Earth ±0.5, 1.2kV	EN61000-4-5, Criteria A
Immunity to conducted disturbances, induced by radio-frequency fields	DC Power Port 10V	EN61000-4-6, Criteria A
Power Magnetic Field Immunity	100A/m continuous; 1000A/m 1s	EN61000-4-8, Criteria A
EMC Compliance Multimedia and IT	Condition	Standard / Criterion
Electromagnetic compatibility of multimedia equipment - Emission requirements	with external filter refer to “EMC Filtering Suggestions”	EN55032, Class A and B
Information technology equipment - Immunity characteristics - Limits and methods of measurement		EN55024:2010 + A1:2015
ESD Electrostatic discharge immunity test	Air ±2, 4, 8kV, Contact ±2, 4, 6kV	IEC61000-4-2:2008, Criteria A
Radiated, radio-frequency, electromagnetic field immunity test	20V/m (80-1000MHz)	IEC61000-4-3:2006+A1:2007 + A2:2010, Criteria A
Fast Transient and Burst Immunity	DC Power Port: ±2kV	IEC61000-4-4:2012, Criteria A
Surge Immunity	DC Power Port: ±2kV	IEC61000-4-5:2014, Criteria A
Immunity to conducted disturbances, induced by radio-frequency fields	DC Power Port 10V	IEC61000-4-6:2013, Criteria A
Power Magnetic Field Immunity	50Hz 100A 1min, 50Hz 1000A 1s	IEC61000-4-8:2009, Criteria A
<p>Notes:</p> <p>Note10: An external input filter capacitor is required if the module has to meet EN61000-4-4, EN61000-4-5 Recom suggests Nippon chemi-con KY series 24Vin, 48Vin=220µF/100V or 110Vin=150µF/200V</p> <p style="text-align: center;">continued on next page</p>		

Specifications (measured @ Ta= 25°C, nom. Vin, full load and after warm-up unless otherwise stated)

EMC Filtering Suggestions according to EN55032

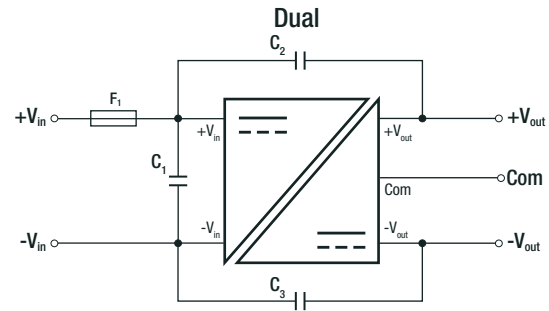
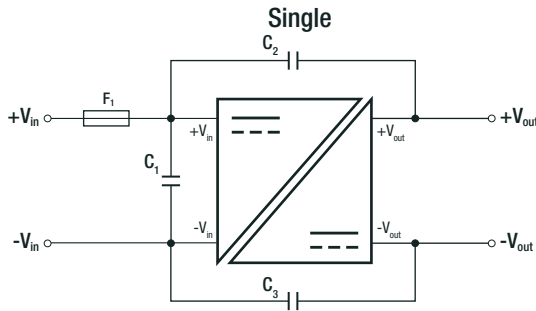

Component List Class A

MODEL	C1	C2	C3
RP08-24xxS_DAW RP08-24xxS_DAW/SMD	1.0µF/50V, 1210MLCC	N/A	1000pF/2kV, 1206 MLCC
RP08-48xxS_DAW RP08-48xxS_DAW/SMD	0.47µF/100V, 1810MLCC	N/A	1000pF/2kV, 1206 MLCC
RP08-110xxS_DAW RP08-110xxS_DAW/SMD	1µF/250V, 1812 MLCC	1µF/250V, 1812 MLCC	1000pF/2kV, 1206 MLCC

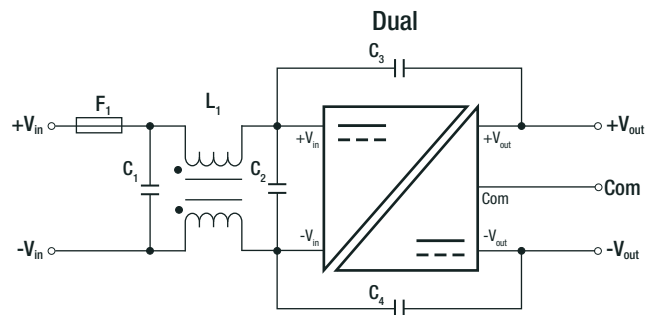
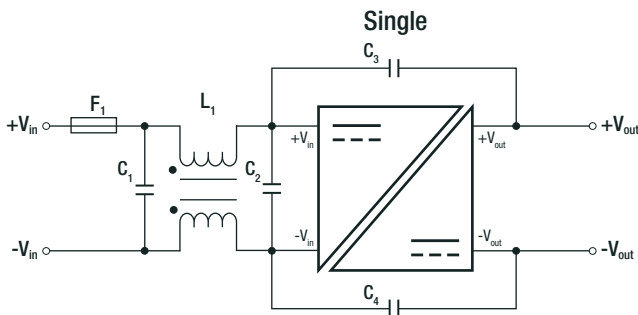

Component List Class B

MODEL	C1	C2	C3/C4	L1
RP08-24xxS_DAW RP08-24xxS_DAW/SMD	4.7µF/50V, 1812 MLCC	N/A	1000pF/2kV, 1206 MLCC	CMC: 325µH ref.: WE 744290321 or CMC-06
RP08-48xxS_DAW RP08-48xxS_DAW/SMD	1.5µF/100V, 1812 MLCC	1.5µF/100V, 1812 MLCC	1000pF/2kV, 1206 MLCC	CMC: 325µH ref.: WE 744290321 or CMC-06
RP08-110xxS_DAW RP08-110xxS_DAW/SMD	1µF/250V, 1812 MLCC	N/A	1000pF/2kV, 1206 MLCC	CMC: 497µH ref.: WE 7448013501

DIMENSIONS and PHYSICAL CHARACTERISTICS

Parameter	Type	Value
Material	case	nickel coated copper
	base	non-conductive black plastic (UL94 V-2)
	potting	epoxy (UL94 V-0)
Dimensions (LxWxH)	DIP24	31.8 x 20.3 x 10.2mm
	SMD	32.0 x 20.3 x 11.2mm
Weight	DIP24	18g
	SMD	20g

continued on next page

Specifications (measured @ Ta= 25°C, nom. Vin, full load and after warm-up unless otherwise stated)

DIP24 Dimension Drawing (mm)

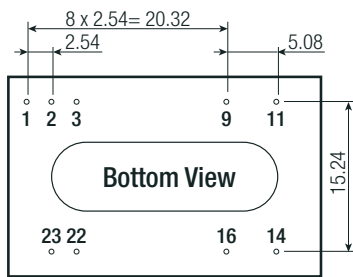
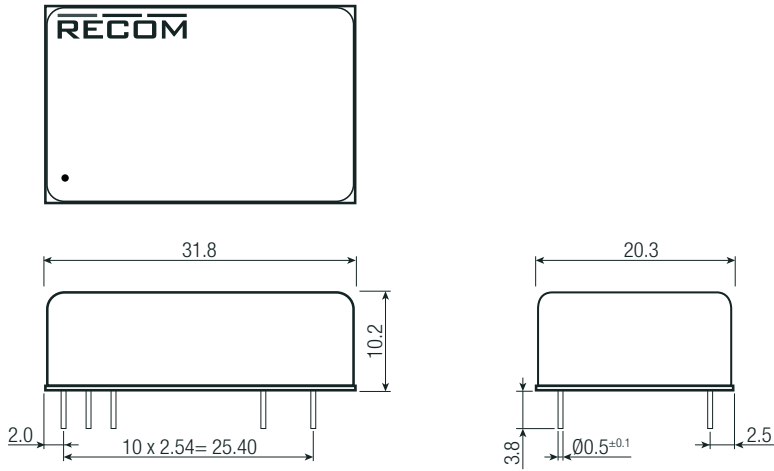
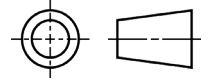

Recommended Footprint Details

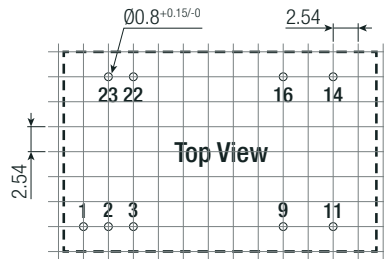

Pin Connections DIP24

Pin #	Single	Dual
1	CTRL	CTRL
2	-Vin	-Vin
3	-Vin	-Vin
9	NC	Com
11	NC	-Vout
14	+Vout	+Vout
16	-Vout	Com
22	+Vin	+Vin
23	+Vin	+Vin

NC = No Connection
Pin Pitch Tolerance $\pm 0.25\text{mm}$
xx.x = $\pm 0.5\text{mm}$
xx.xx = $\pm 0.25\text{mm}$

SMD Dimension Drawing (mm)

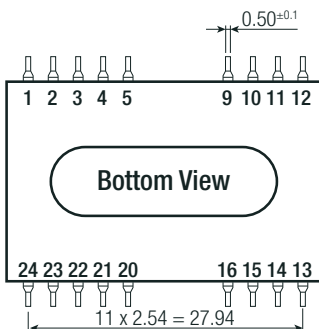
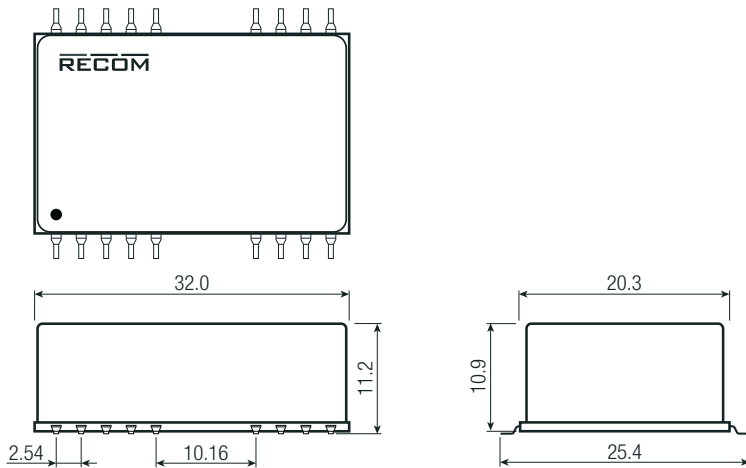

Recommended Footprint Details

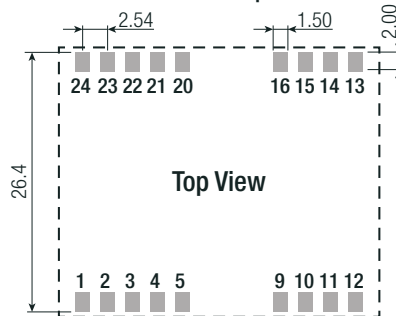

Pin Connections SMD

Pin #	Single	Dual
1	CTRL	CTRL
2	-Vin	-Vin
3	-Vin	-Vin
9	NC	Com
11	NC	-Vout
14	+Vout	+Vout
16	-Vout	Com
22	+Vin	+Vin
23	+Vin	+Vin
Others	NC	NC

NC = No Connection
Pin Pitch Tolerance $\pm 0.25\text{mm}$
xx.x = $\pm 0.5\text{mm}$
xx.xx = $\pm 0.25\text{mm}$

Specifications (measured @ Ta= 25°C, nom. Vin, full load and after warm-up unless otherwise stated)

PACKAGING INFORMATION			
Parameter	Type		Value
Packaging Dimension (LxWxH)	tube	DIP24	255.0 x 23.0 x 19.0mm
		SMD	255.0 x 32.0 x 16.0mm
Packaging Quantity	DIP24, SMD		7pcs
Storage Temperature Range			-55°C to +125°C
Storage Humidity	non-condensing		5% - 95% RH

The product information and specifications may be subject to changes even without prior written notice. The product has been designed for various applications; its suitability lies in the responsibility of each customer. The products are not authorized for use in safety-critical applications without RECOM's explicit written consent. A safety-critical application is an application where a failure may reasonably be expected to endanger or cause loss of life, inflict bodily harm or damage property. The applicant shall indemnify and hold harmless RECOM, its affiliated companies and its representatives against any damage claims in connection with the unauthorized use of RECOM products in such safety-critical applications.

Looking for pricing, stock, or lifecycle information?

Click below to explore more details on WIN SOURCE:

- ⊖ [View RP08-11015SAW](#) on WIN SOURCE
- ⊖ [Recom Power](#) Information

Optimize Your Supply Chain with WIN SOURCE Solutions

- ✓ Global Sourcing Solution
- ✓ Obsolete Management
- ✓ Cost Control Management
- ✓ Shortage Management
- ✓ Alternative Solution
- ✓ Excess Inventory Management