



THE DATASHEET OF
843004AG-01LF



GENERAL DESCRIPTION

The 843004-01 is a 4 output LVPECL synthesizer optimized to generate Ethernet reference clock frequencies and is a member of the family of high performance clock solutions from IDT. Using a 25MHz 18pF parallel resonant crystal, the following frequencies can be generated based on the settings of 2 frequency select pins (F_SEL[1:0]): 156.25MHz, 125MHz, 62.5MHz. The 843004-01 uses IDT's 3rd generation low phase noise VCO technology and can achieve 1ps or lower typical rms phase jitter, easily meeting Ethernet jitter requirements. The 843004-01 is packaged in a small 24-pin TSSOP package.

FEATURES

- Four 3.3V LVPECL outputs
- Selectable crystal oscillator interface or LVCMOS/LVTTL single-ended input
- Supports the following output frequencies: 156.25MHz, 125MHz and 62.5MHz
- VCO range: 560MHz - 680MHz
- RMS phase jitter @ 156.25MHz, using a 25MHz crystal (1.875MHz - 20MHz): 0.57ps (typical)
- RMS phase noise at 156.25MHz (typical)

Phase noise:

Offset	Noise Power
100Hz	-95.5 dBc/Hz
1kHz	-118 dBc/Hz
10kHz	-126 dBc/Hz
100kHz	-126.6 dBc/Hz

- Full 3.3V supply mode
- -30°C to 85°C ambient operating temperature
- Available in lead-free RoHS compliant package

FREQUENCY SELECT FUNCTION TABLE

Inputs					Output Frequency (25MHz Ref.)
F_SEL1	F_SEL0	M Divider Value	N Divider Value	M/N Divider Value	
0	0	25	4	6.25	156.25
0	1	25	5	5	125
1	0	25	10	2.5	62.5
1	1	25	not used		not used

BLOCK DIAGRAM

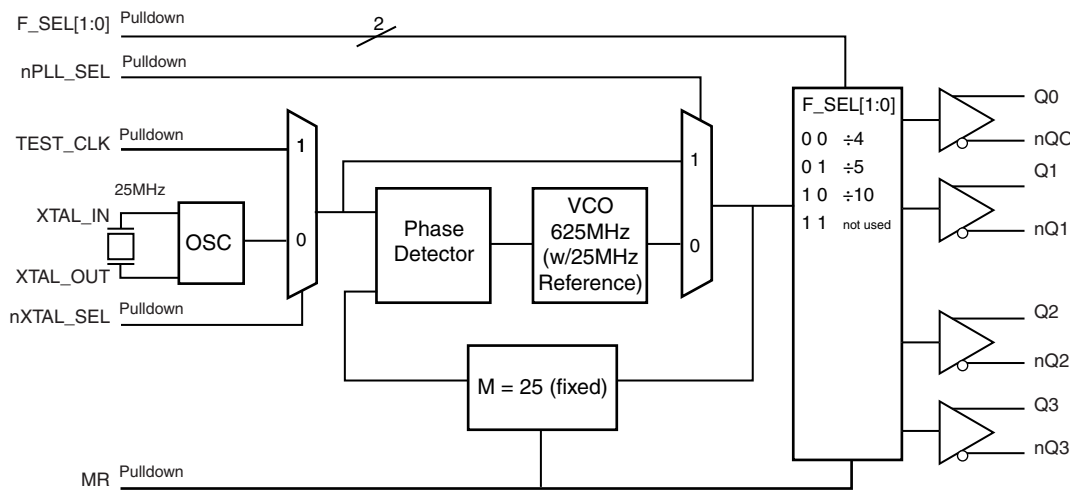

PIN ASSIGNMENT

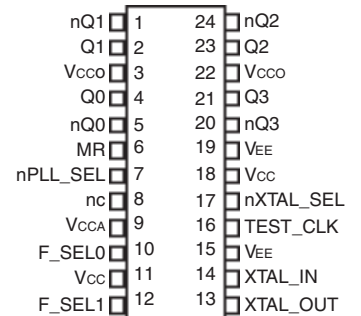

843004-01

24-Lead TSSOP

4.40mm x 7.8mm x 0.92mm
package body
G Package
Top View

TABLE 1. PIN DESCRIPTIONS

Number	Name	Type		Description
1, 2	nQ1, Q1	Output		Differential output pair. LVPECL interface levels.
3, 22	V _{CC0}	Power		Output supply pins.
4, 5	Q0, nQ0	Output		Differential output pair. LVPECL interface levels.
6	MR	Input	Pulldown	Active HIGH Master Reset. When logic HIGH, the internal dividers are reset causing the true outputs Qx to go low and the inverted outputs nQx to go high. When logic LOW, the internal dividers and the outputs are enabled. LVCMOS/LVTTL interface levels.
7	nPLL_SEL	Input	Pulldown	Selects between the PLL and TEST_CLK as input to the dividers. When LOW, selects PLL (PLL Enable). When HIGH, deselects the reference clock (PLL Bypass). LVCMOS/LVTTL interface levels.
8	nc	Unused		No connect.
9	V _{CCA}	Power		Analog supply pin.
10, 12	F_SEL0, F_SEL1	Input	Pulldown	Frequency select pins. LVCMOS/LVTTL interface levels.
11, 18	V _{CC}	Power		Core supply pin.
13, 14	XTAL_OUT, XTAL_IN	Input		Parallel resonant crystal interface. XTAL_OUT is the output, XTAL_IN is the input.
15, 19	V _{EE}	Power		Negative supply pins.
16	TEST_CLK	Input	Pulldown	LVCMOS/LVTTL clock input.
17	nXTAL_SEL	Input	Pulldown	Selects between crystal or TEST_CLK inputs as the the PLL Reference source. Selects XTAL inputs when LOW. Selects TEST_CLK when HIGH. LVCMOS/LVTTL interface levels.
20, 21	nQ3, Q3	Output		Differential output pair. LVPECL interface levels.
23, 24	Q2, nQ2	Output		Differential output pair. LVPECL interface levels.

NOTE: refers to internal input resistors. See Table 2, Pin Characteristics, for typical values.

TABLE 2. PIN CHARACTERISTICS

Symbol	Parameter	Test Conditions	Minimum	Typical	Maximum	Units
C _{IN}	Input Capacitance			4		pF
R _{PULLDOWN}	Input Pulldown Resistor			51		kΩ

ABSOLUTE MAXIMUM RATINGS

Supply Voltage, V_{CC}	4.6V
Inputs, V_I	-0.5V to $V_{CC} + 0.5V$
Outputs, I_O	
Continuous Current	50mA
Surge Current	100mA
Package Thermal Impedance, θ_{JA}	70°C/W (0 mps)
Storage Temperature, T_{STG}	-65°C to 150°C

NOTE: Stresses beyond those listed under Absolute Maximum Ratings may cause permanent damage to the device. These ratings are stress specifications only. Functional operation of product at these conditions or any conditions beyond those listed in the *DC Characteristics* or *AC Characteristics* is not implied. Exposure to absolute maximum rating conditions for extended periods may affect product reliability.

TABLE 3A. POWER SUPPLY DC CHARACTERISTICS, $V_{CC} = V_{CCA} = V_{CCO} = 3.3V \pm 5\%$, $T_A = -30^\circ C$ TO $85^\circ C$

Symbol	Parameter	Test Conditions	Minimum	Typical	Maximum	Units
V_{CC}	Core Supply Voltage		3.135	3.3	3.465	V
V_{CCA}	Analog Supply Voltage		3.135	3.3	3.465	V
V_{CCO}	Output Supply Voltage		3.135	3.3	3.465	V
I_{EE}	Power Supply Current				135	mA
I_{CCA}	Analog Supply Current	Included in I_{EE}			15	mA

TABLE 3B. LVCMOS / LVTTTL DC CHARACTERISTICS, $V_{CC} = V_{CCA} = V_{CCO} = 3.3V \pm 5\%$, $T_A = -30^\circ C$ TO $85^\circ C$

Symbol	Parameter	Test Conditions	Minimum	Typical	Maximum	Units
V_{IH}	Input High Voltage		2		$V_{CC} + 0.3$	V
V_{IL}	Input Low Voltage	nPLL_SEL, nXTAL_SEL, F_SEL0, F_SEL1, MR	-0.3		0.8	V
		TEST_CLK	-0.3		1.3	V
I_{IH}	Input High Current	TEST_CLK, MR, nPLL_SEL, nXTAL_SEL, F_SEL0, F_SEL1 $V_{CC} = V_{IN} = 3.465V$			150	μA
I_{IL}	Input Low Current	TEST_CLK, MR, nPLL_SEL, nXTAL_SEL, F_SEL0, F_SEL1 $V_{CC} = 3.465V, V_{IN} = 0V$	-5			μA

TABLE 3C. LVPECL DC CHARACTERISTICS, $V_{CC} = V_{CCA} = V_{CCO} = 3.3V \pm 5\%$, $T_A = -30^\circ C$ TO $85^\circ C$

Symbol	Parameter	Test Conditions	Minimum	Typical	Maximum	Units
V_{OH}	Output High Voltage; NOTE 1		$V_{CCO} - 1.4$		$V_{CCO} - 0.9$	V
V_{OL}	Output Low Voltage; NOTE 1		$V_{CCO} - 2.0$		$V_{CCO} - 1.7$	V
V_{SWING}	Peak-to-Peak Output Voltage Swing		0.6		1.0	V

NOTE 1: Outputs terminated with 50 to $V_{CCO} - 2V$.

TABLE 4. CRYSTAL CHARACTERISTICS

Parameter	Test Conditions	Minimum	Typical	Maximum	Units
Mode of Oscillation		Fundamental			
Frequency			25		MHz
Equivalent Series Resistance (ESR)				50	Ω
Shunt Capacitance				7	pF

NOTE: Characterized using an 18pF parallel resonant crystal.

TABLE 5. AC CHARACTERISTICS, $V_{CC} = V_{CCA} = V_{CCO} = 3.3V \pm 5\%$, $T_A = -30^\circ C$ TO $85^\circ C$

Symbol	Parameter	Test Conditions	Minimum	Typical	Maximum	Units
f_{OUT}	Output Frequency	F_SEL[1:0] = 00	140		170	MHz
		F_SEL[1:0] = 01	112		136	MHz
		F_SEL[1:0] = 10	56		68	MHz
tsk(o)	Output Skew; NOTE 1, 2			30	ps	
tjit(\emptyset)	RMS Phase Jitter; NOTE 3	156.25MHz (1.875MHz - 20MHz)		0.57		ps
		125MHz (1.875MHz - 20MHz)		0.63		ps
		62.5MHz (1.875MHz - 20MHz)		0.81		ps
t_R / t_F	Output Rise/Fall Time	20% to 80%	300		600	ps
odc	Output Duty Cycle		49		51	%

NOTE 1: Defined as skew between outputs at the same supply voltages and with equal load conditions. Measured at $V_{CCO}/2$.

NOTE 2: This parameter is defined in accordance with JEDEC Standard 65.

NOTE 3: Phase jitter is dependent on the input source used.

TYPICAL PHASE NOISE AT 62.5MHz

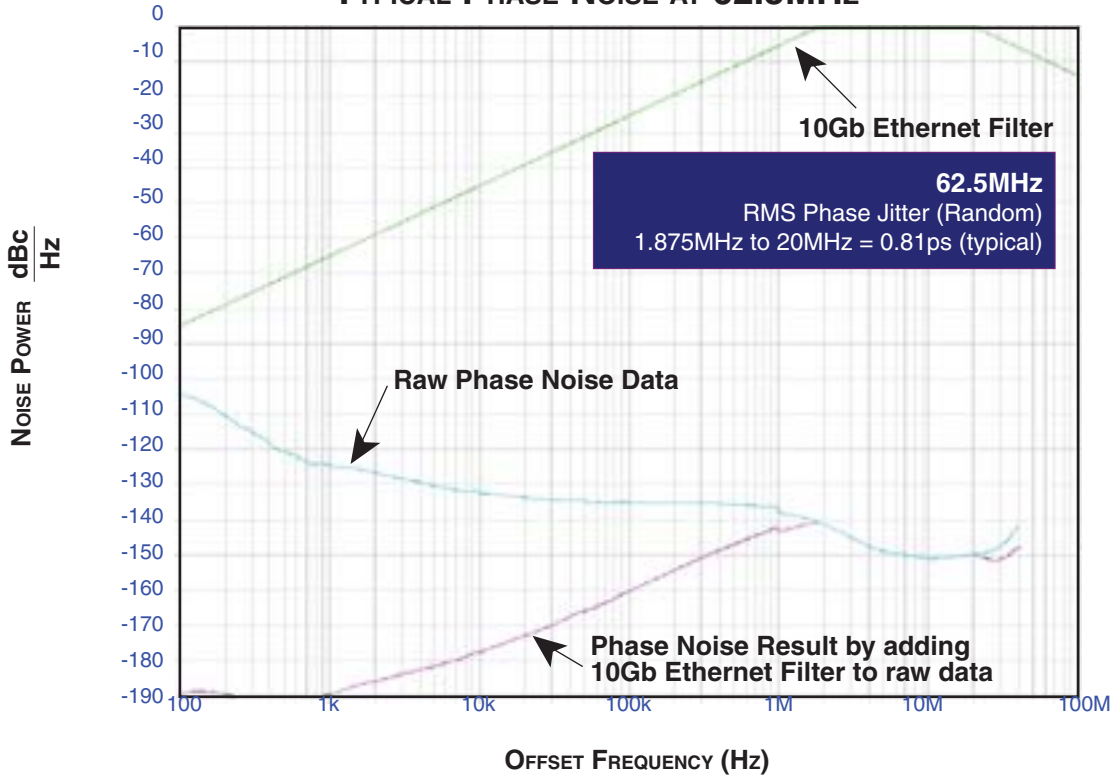

TYPICAL PHASE NOISE AT 125MHz

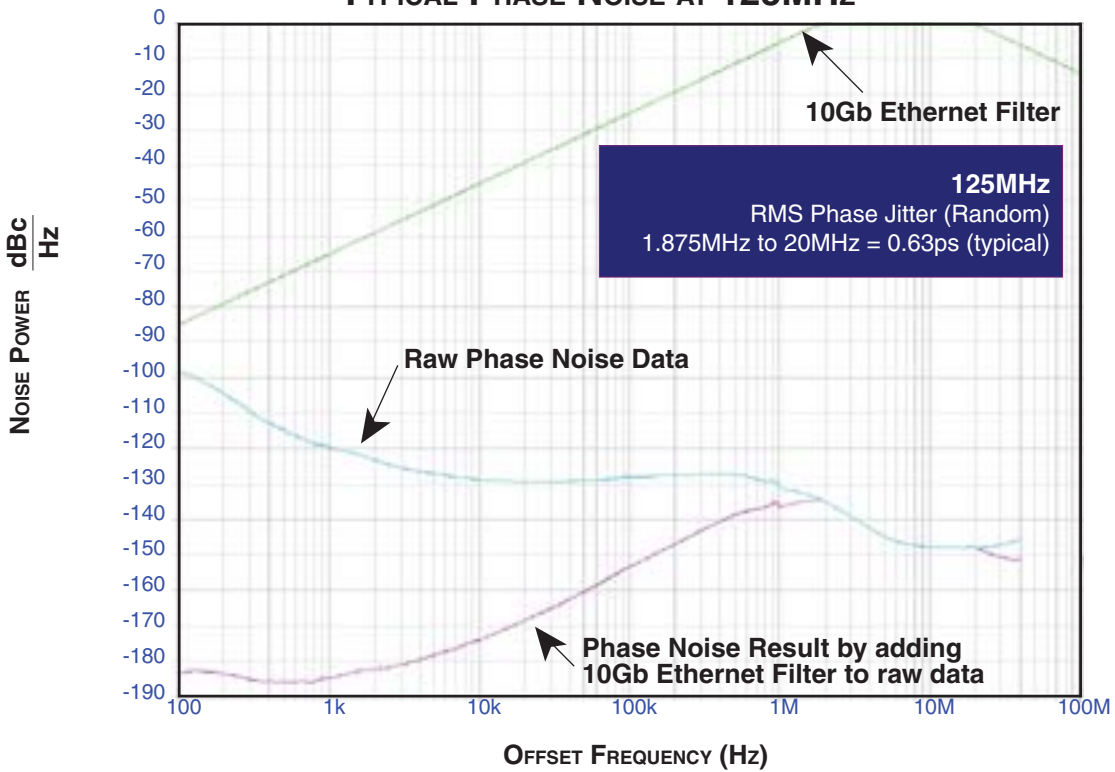

TYPICAL PHASE NOISE AT 156.25MHz

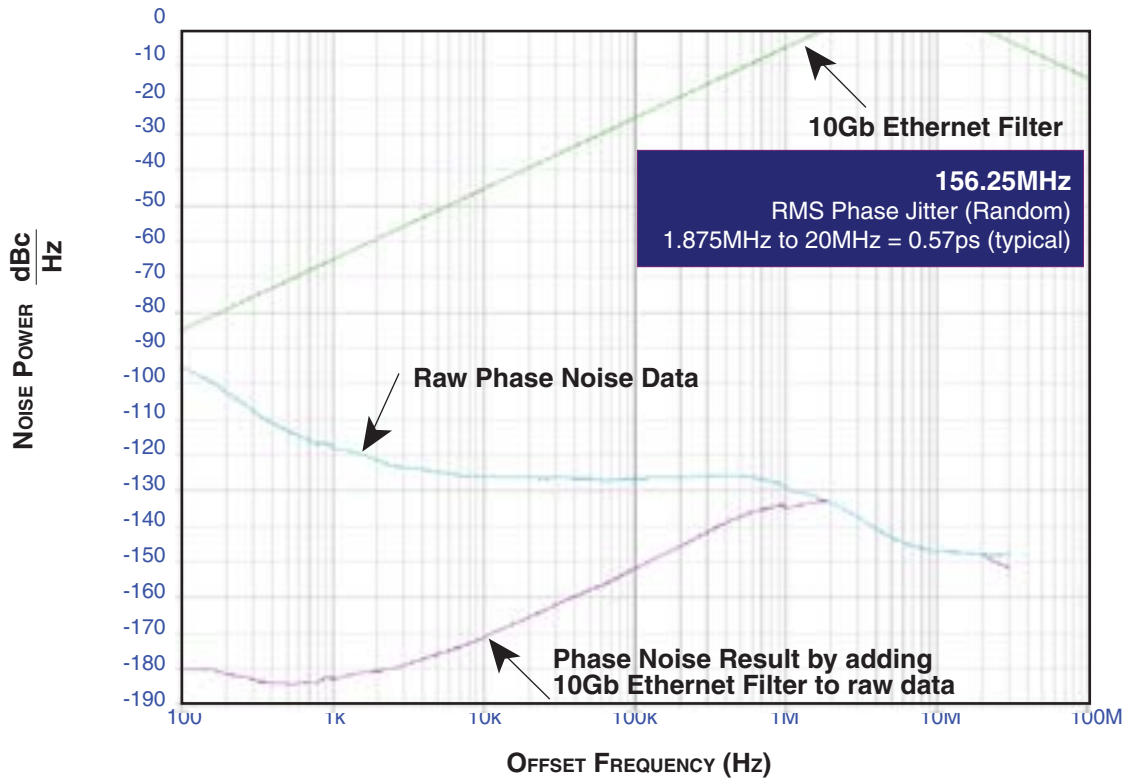

PARAMETER MEASUREMENT INFORMATION

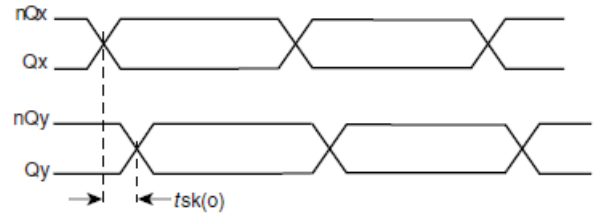
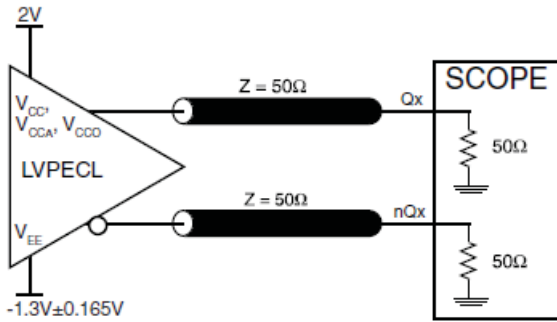

3.3V CORE/3.3V OUTPUT LOAD AC TEST CIRCUIT

OUTPUT SKEW

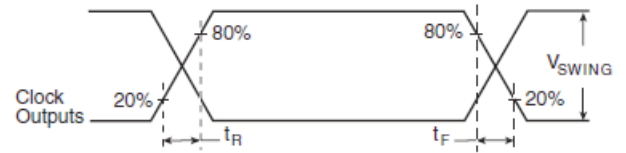
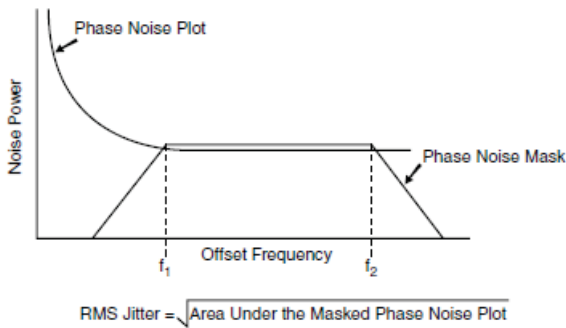

RMS PHASE JITTER

OUTPUT RISE/FALL TIME

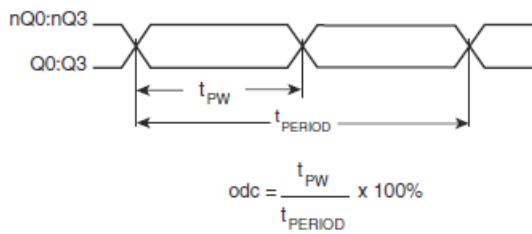

OUTPUT DUTY CYCLE/PULSE WIDTH/PERIOD

APPLICATION INFORMATION

POWER SUPPLY FILTERING TECHNIQUES

As in any high speed analog circuitry, the power supply pins are vulnerable to random noise. The 843004-01 provides separate power supplies to isolate any high switching noise from the outputs to the internal PLL. V_{CC} , V_{CCA} , and V_{CCO} should be individually connected to the power supply plane through vias, and bypass capacitors should be used for each pin. To achieve optimum jitter performance, power supply isolation is required. *Figure 1* illustrates how a 10Ω resistor along with a $10\mu\text{F}$ and a $.01\mu\text{F}$ bypass capacitor should be connected to each V_{CCA} .

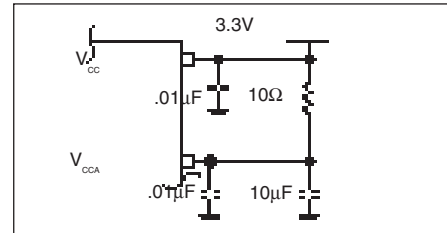

FIGURE 1. POWER SUPPLY FILTERING

RECOMMENDATIONS FOR UNUSED INPUT AND OUTPUT PINS

INPUTS:

CRYSTAL INPUT:

For applications not requiring the use of the crystal oscillator input, both XTAL_IN and XTAL_OUT can be left floating. Though not required, but for additional protection, a $1\text{k}\Omega$ resistor can be tied from XTAL_IN to ground.

TEST_CLK INPUT:

For applications not requiring the use of the test clock, it can be left floating. Though not required, but for additional protection, a $1\text{k}\Omega$ resistor can be tied from the TEST_CLK to ground.

LVC MOS CONTROL PINS:

All control pins have internal pull-ups or pull-downs; additional resistance is not required but can be added for additional protection. A $1\text{k}\Omega$ resistor can be used.

OUTPUTS:

LVPECL OUTPUT

All unused LVPECL outputs can be left floating. We recommend that there is no trace attached. Both sides of the differential output pair should either be left floating or terminated.

CRYSTAL INPUT INTERFACE

The 843004-01 has been characterized with 18pF parallel resonant crystals. The capacitor values shown in *Figure 2* below were

determined using a 25MHz , 18pF parallel resonant crystal and were chosen to minimize the ppm error.

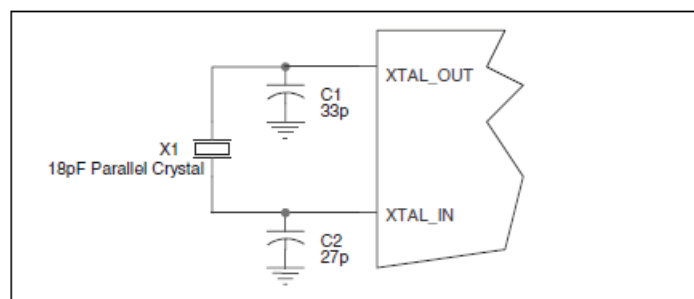

Figure 2. CRYSTAL INPUT INTERFACE

LVC MOS TO XTAL INTERFACE

The XTAL_IN input can accept a single-ended LVC MOS signal through an AC coupling capacitor. A general interface diagram is shown in *Figure X*. The XTAL_OUT pin can be left floating. The input edge rate can be as slow as 10ns. For LVC MOS inputs, it is recommended that the amplitude be reduced from full swing to half swing in order to prevent signal interference with the power rail and to reduce noise. This configuration requires that the output

impedance of the driver (R_o) plus the series resistance (R_s) equals the transmission line impedance. In addition, matched termination at the crystal input will attenuate the signal in half. This can be done in one of two ways. First, R_1 and R_2 in parallel should equal the transmission line impedance. For most 50Ω applications, R_1 and R_2 can be 100Ω . This can also be accomplished by removing R_1 and making R_2 50Ω .

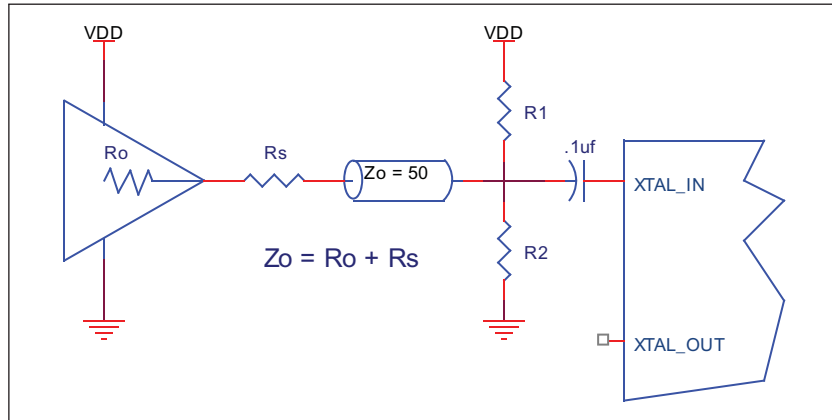

FIGURE 3. GENERAL DIAGRAM FOR LVC MOS DRIVER TO XTAL INPUT INTERFACE

TERMINATION FOR 3.3V LVPECL OUTPUT

The clock layout topology shown below is a typical termination for LVPECL outputs. The two different layouts mentioned are recommended only as guidelines.

FOUT and nFOUT are low impedance follower outputs that generate ECL/LVPECL compatible outputs. Therefore, terminating resistors (DC current path to ground) or current sources must be used for functionality. These outputs are designed to drive 50Ω transmission

lines. Matched impedance techniques should be used to maximize operating frequency and minimize signal distortion. *Figures 4A and 4B* show two different layouts which are recommended only as guidelines. Other suitable clock layouts may exist and it would be recommended that the board designers simulate to guarantee compatibility across all printed circuit and clock component process variations.

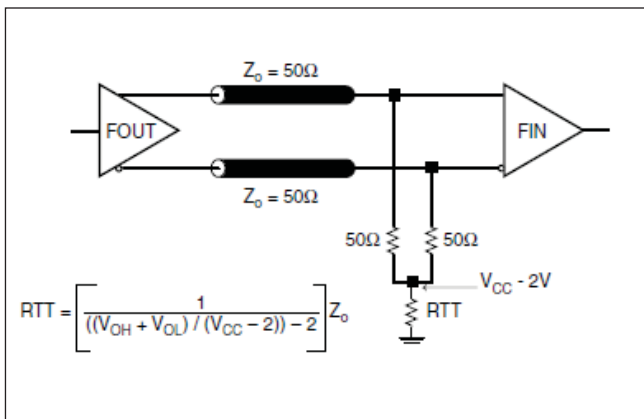

FIGURE 4A. LVPECL OUTPUT TERMINATION

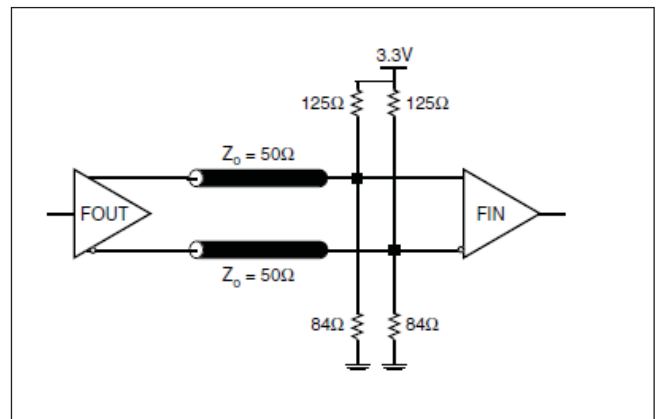

FIGURE 4B. LVPECL OUTPUT TERMINATION

LAYOUT GUIDELINE

Figure 5 shows a schematic example of the 843004-01. An example of LVEPCL termination is shown in this schematic. Additional LVPECL termination approaches are shown in the LVPECL Termination Application Note. In this example, an 18pF parallel

resonant 25MHz crystal is used. The C1=27pF and C2=33pF are recommended for frequency accuracy. For different board layout, the C1 and C2 may be slightly adjusted for optimizing frequency accuracy.

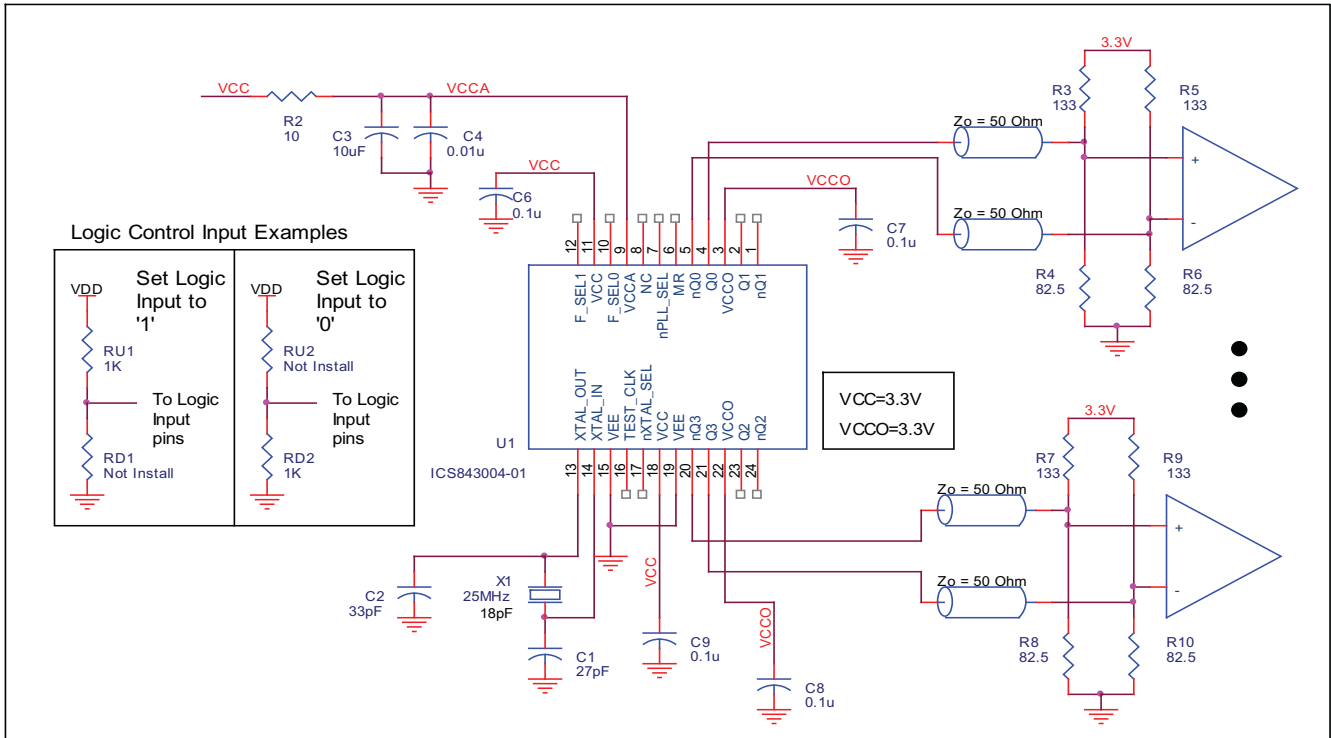

FIGURE 5. 843004-01 SCHEMATIC EXAMPLE

POWER CONSIDERATIONS

This section provides information on power dissipation and junction temperature for the 843004-01. Equations and example calculations are also provided.

1. Power Dissipation.

The total power dissipation for the 843004-01 is the sum of the core power plus the power dissipated in the load(s). The following is the power dissipation for $V_{CC} = 3.3V + 5\% = 3.465V$, which gives worst case results.

NOTE: Please refer to Section 3 for details on calculating power dissipated in the load.

- Power (core)_{MAX} = $V_{CC_MAX} * I_{EE_MAX} = 3.465V * 135mA = 467.8mW$
- Power (outputs)_{MAX} = **30mW/Loaded Output pair**
If all outputs are loaded, the total power is $4 * 30mW = 120mW$

Total Power_{MAX} (3.465V, with all outputs switching) = $467.8mW + 120mW = 587.8mW$

2. Junction Temperature.

Junction temperature, T_j, is the temperature at the junction of the bond wire and bond pad and directly affects the reliability of the device. The maximum recommended junction temperature for HiPerClockS™ devices is 125°C.

The equation for T_j is as follows: $T_j = \theta_{JA} * Pd_total + T_A$

T_j = Junction Temperature

θ_{JA} = Junction-to-Ambient Thermal Resistance

Pd_{total} = Total Device Power Dissipation (example calculation is in section 1 above)

T_A = Ambient Temperature

In order to calculate junction temperature, the appropriate junction-to-ambient thermal resistance θ_{JA} must be used. Assuming a moderate air flow of 1 meter per second and a multi-layer board, the appropriate value is 65°C/W per Table 6 below.

Therefore, T_j for an ambient temperature of 85°C with all outputs switching is:
 $85°C + 0.588W * 65°C/W = 123.2°C$. This is below the limit of 125°C.

This calculation is only an example. T_j will obviously vary depending on the number of loaded outputs, supply voltage, air flow, and the type of board (single layer or multi-layer).

TABLE 6. THERMAL RESISTANCE θ_{JA} FOR 24-PIN TSSOP, FORCED CONVECTION

θ_{JA} by Velocity (Meters per Second)			
	0	1	2.5
Multi-Layer PCB, JEDEC Standard Test Boards	70°C/W	65°C/W	62°C/W

3. Calculations and Equations.

The purpose of this section is to derive the power dissipated into the load.

LVPECL output driver circuit and termination are shown in Figure 6.

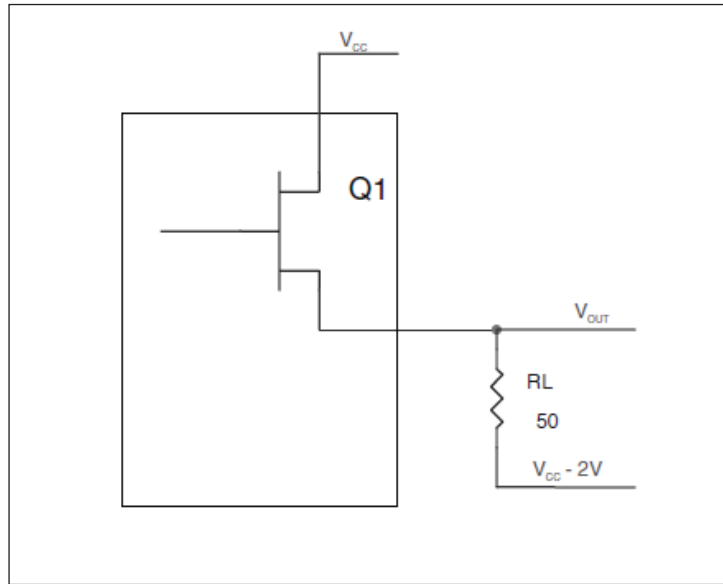

FIGURE 6. LVPECL DRIVER CIRCUIT AND TERMINATION

To calculate worst case power dissipation into the load, use the following equations which assume a 50Ω load, and a termination voltage of $V_{cc} - 2V$.

- For logic high, $V_{OUT} = V_{OH_MAX} = V_{CC_MAX} - 0.9V$

$$(V_{CC_MAX} - V_{OH_MAX}) = 0.9V$$

- For logic low, $V_{OUT} = V_{OL_MAX} = V_{CC_MAX} - 1.7V$

$$(V_{CC_MAX} - V_{OL_MAX}) = 1.7V$$

Pd_H is power dissipation when the output drives high.

Pd_L is the power dissipation when the output drives low.

$$Pd_H = [(V_{OH_MAX} - (V_{CC_MAX} - 2V))/R_L] * (V_{CC_MAX} - V_{OH_MAX}) = [(2V - (V_{CC_MAX} - V_{OH_MAX}))/R_L] * (V_{CC_MAX} - V_{OH_MAX}) = [(2V - 0.9V)/50\Omega] * 0.9V = 19.8mW$$

$$Pd_L = [(V_{OL_MAX} - (V_{CC_MAX} - 2V))/R_L] * (V_{CC_MAX} - V_{OL_MAX}) = [(2V - (V_{CC_MAX} - V_{OL_MAX}))/R_L] * (V_{CC_MAX} - V_{OL_MAX}) = [(2V - 1.7V)/50\Omega] * 1.7V = 10.2mW$$

$$\text{Total Power Dissipation per output pair} = Pd_H + Pd_L = 30mW$$

RELIABILITY INFORMATION

TABLE 7. θ_{JA} VS. AIR FLOW TABLE FOR 24 LEAD TSSOP

θ_{JA} by Velocity (Meters per Second)			
	0	1	2.5
Multi-Layer PCB, JEDEC Standard Test Boards	70°C/W	65°C/W	62°C/W

TRANSISTOR COUNT

The transistor count for 843004-01 is: 3183

PACKAGE OUTLINE - G SUFFIX FOR 24 LEAD TSSOP

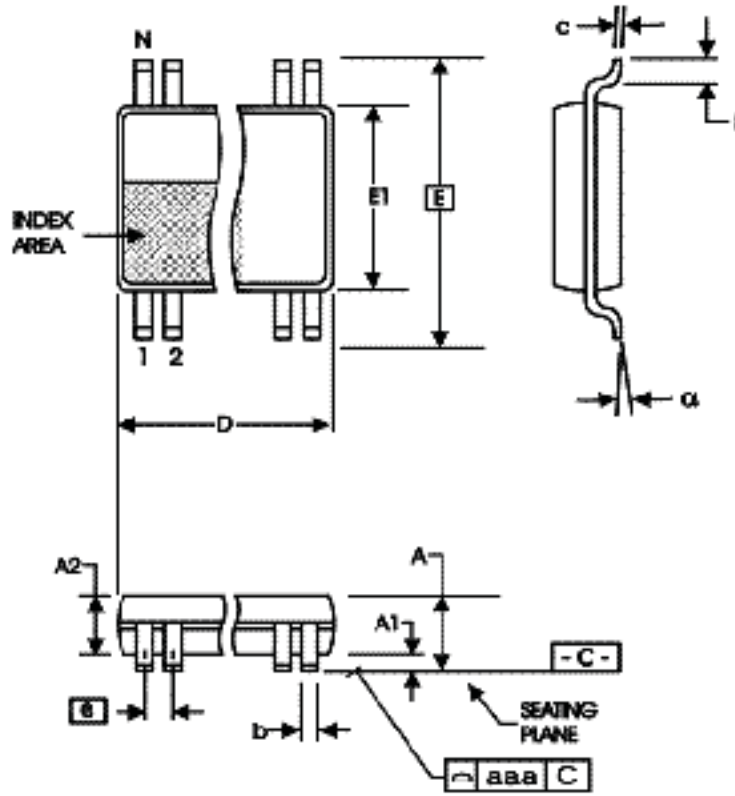

TABLE 8. PACKAGE DIMENSIONS

SYMBOL	Millimeters	
	Minimum	Maximum
N	24	
A	--	1.20
A1	0.05	0.15
A2	0.80	1.05
b	0.19	0.30
c	0.09	0.20
D	7.70	7.90
E	6.40 BASIC	
E1	4.30	4.50
e	0.65 BASIC	
L	0.45	0.75
α	0°	8°
aaa	--	0.10

Reference Document: JEDEC Publication 95, MO-153

TABLE 9. ORDERING INFORMATION

Part/Order Number	Marking	Package	Shipping Packaging	Temperature
843004AG-01LF	ICS43004A01L	24 Lead "Lead-Free" TSSOP	tube	-30°C to 85°C
843004AG-01LFT	ICS43004A01L	24 Lead "Lead-Free" TSSOP	tape & reel	-30°C to 85°C

REVISION HISTORY SHEET				
Rev	Table	Page	Description of Change	Date
B	T5	4	AC Characteristics Table - deleted Propagation Delay row.	5/6/05
B	T9	1	Features Section - added lead-free bullet.	6/30/06
		9 15	Added - LVCMOS to XTAL Interface and Recommendations for Unused Input and Output Pins sections. Ordering Information Table - added lead-free part number, marking and note.	
B	T9	15	Ordering Information Table - removed leaded devices - PDN CQ-13-02 expired. Updated datasheet format.	12/9/14
B	T9	1	General Description - Removed Hiperlocks and changed ICS to IDT.	1/18/16
		15	Ordering Information - Removed ICS in the Part/Order number and removed LF note below the table. Updated data sheet header and footer.	

IMPORTANT NOTICE AND DISCLAIMER

RENESAS ELECTRONICS CORPORATION AND ITS SUBSIDIARIES (“RENESAS”) PROVIDES TECHNICAL SPECIFICATIONS AND RELIABILITY DATA (INCLUDING DATASHEETS), DESIGN RESOURCES (INCLUDING REFERENCE DESIGNS), APPLICATION OR OTHER DESIGN ADVICE, WEB TOOLS, SAFETY INFORMATION, AND OTHER RESOURCES “AS IS” AND WITH ALL FAULTS, AND DISCLAIMS ALL WARRANTIES, EXPRESS OR IMPLIED, INCLUDING, WITHOUT LIMITATION, ANY IMPLIED WARRANTIES OF MERCHANTABILITY, FITNESS FOR A PARTICULAR PURPOSE, OR NON-INFRINGEMENT OF THIRD-PARTY INTELLECTUAL PROPERTY RIGHTS.

These resources are intended for developers who are designing with Renesas products. You are solely responsible for (1) selecting the appropriate products for your application, (2) designing, validating, and testing your application, and (3) ensuring your application meets applicable standards, and any other safety, security, or other requirements. These resources are subject to change without notice. Renesas grants you permission to use these resources only to develop an application that uses Renesas products. Other reproduction or use of these resources is strictly prohibited. No license is granted to any other Renesas intellectual property or to any third-party intellectual property. Renesas disclaims responsibility for, and you will fully indemnify Renesas and its representatives against, any claims, damages, costs, losses, or liabilities arising from your use of these resources. Renesas' products are provided only subject to Renesas' Terms and Conditions of Sale or other applicable terms agreed to in writing. No use of any Renesas resources expands or otherwise alters any applicable warranties or warranty disclaimers for these products.

(Disclaimer Rev.1.01 Jan 2024)

Corporate Headquarters

TOYOSU FORESIA, 3-2-24 Toyosu,
Koto-ku, Tokyo 135-0061, Japan
www.renesas.com

Trademarks

Renesas and the Renesas logo are trademarks of Renesas Electronics Corporation. All trademarks and registered trademarks are the property of their respective owners.

Contact Information

For further information on a product, technology, the most up-to-date version of a document, or your nearest sales office, please visit www.renesas.com/contact-us/.

Looking for pricing, stock, or lifecycle information?

Click below to explore more details on WIN SOURCE:

-  [View 843004AG-01LF on WIN SOURCE](#)
-  [Renesas Electronics America](#) Information

Optimize Your Supply Chain with WIN SOURCE Solutions

-  Global Sourcing Solution
-  Obsolete Management
-  Cost Control Management
-  Shortage Management
-  Alternative Solution
-  Excess Inventory Management