



**THE DATASHEET OF  
HEL-776-A-U-1**



# Honeywell

## Interactive Catalog Replaces Catalog Pages

Honeywell Sensing and Control has replaced the PDF product catalog with the new **Interactive Catalog**. The **Interactive Catalog** is a power search tool that makes it easier to find product information. It includes more installation, application, and technical information than ever before.



Click this icon to try the new Interactive Catalog.

---

**Sensing and Control**  
Honeywell Inc.  
11 West Spring Street  
Freeport, Illinois 61032



# Temperature Sensors

## Platinum RTDs

HEL-776/HEL-777



### FEATURES

- Linear resistance vs temperature
- Accurate and interchangeable
- Excellent stability
- Small size
- Printed circuit mountable
- Ceramic SIP package

### TYPICAL APPLICATIONS

- HVAC – room, duct and refrigerant equipment
- Instrument and probe assemblies
- Electronic assemblies – temperature compensation
- Process control – temperature regulation

HEL-776 and HEL-777 platinum RTDs are designed to measure temperatures from  $-55^{\circ}\text{C}$  to  $+150^{\circ}\text{C}$  ( $-67^{\circ}$  to  $302^{\circ}\text{F}$ ) in printed circuit boards, temperature probes, or other lower temperature applications. Solderable leads in 0.050" or 0.100" spacing provide strong connections for wires or printed circuits.

The 1000Ω, 375 alpha version, provides 10x greater sensitivity and signal-to-noise. Both are ideal for air temperature sensing.

### ORDER GUIDE

HEL-776-A	Molded SIP pkg. 0.100" lead spacing
HEL-777-A	Molded SIP pkg. 0.100" lead spacing
-U	1000Ω, 0.00375 Ω/Ω/°C
-T	100Ω, 0.00385 Ω/Ω/°C
-0	±0.2% Resistance Trim (Standard)
-1	±0.1% Resistance Trim (Optional)

### MOUNTING DIMENSIONS (for reference only) mm/in.

#### HEL-776-A

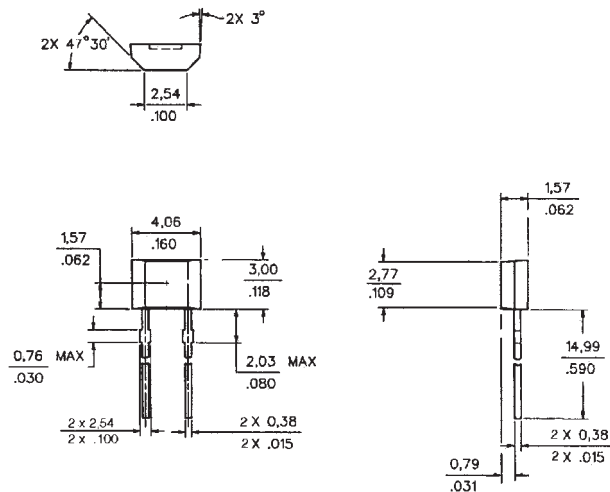

#### HEL-777-A

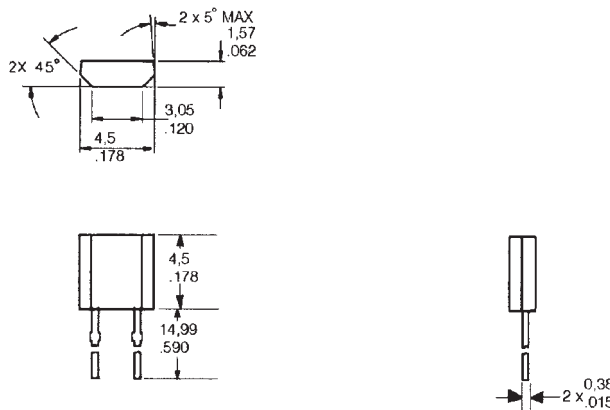

Fig. 1: Wheatstone Bridge 2-Wire Interface

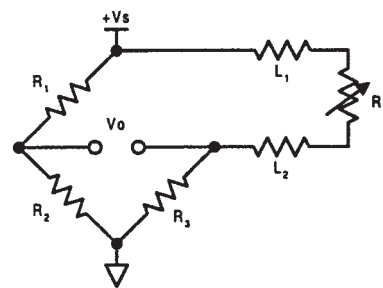

Fig. 2: Linear Output Voltage

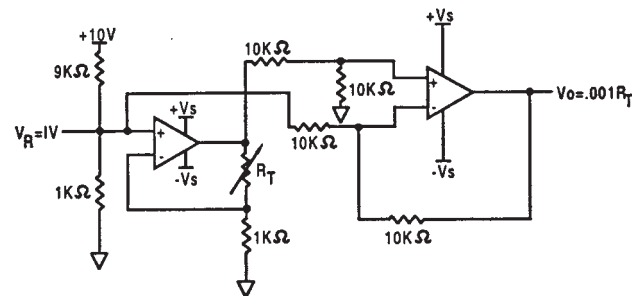
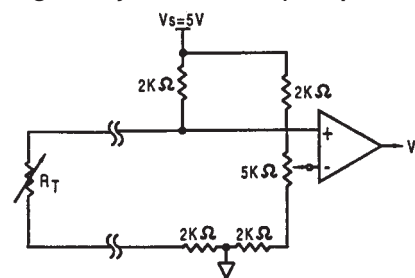

Fig. 3: Adjustable Point (Comparator) Interface



### CAUTION PRODUCT DAMAGE

The inherent design of this component causes it to be sensitive to electrostatic discharge (ESD). To prevent ESD-induced damage and/or degradation, take normal ESD precautions when handling this product.

Temperature

## Platinum RTDs

### FUNCTIONAL BEHAVIOR

$$R_T = R_0(1 + AT + BT^2 - 100CT^3 + CT^4)$$

$R_T$  = Resistance ( $\Omega$ ) at temperature  $T$  ( $^{\circ}\text{C}$ )

$R_0$  = Resistance ( $\Omega$ ) at  $0^{\circ}\text{C}$

$T$  = Temperature in  $^{\circ}\text{C}$

$$A = \alpha + \frac{\alpha \delta}{100} \quad B = \frac{-\alpha \delta}{100^2} \quad C_{T < 0} = \frac{-\alpha \beta}{100^4}$$

### CONSTANTS

<b>Alpha, <math>\alpha</math> (<math>^{\circ}\text{C}^{-1}</math>)</b>	0.00375 $\pm 0.000029$	0.003850 $\pm 0.000010$
<b>Delta, <math>\delta</math> (<math>^{\circ}\text{C}</math>)</b>	$1.605 \pm 0.009$	$1.4999 \pm 0.007$
<b>Beta, <math>\beta</math> (<math>^{\circ}\text{C}</math>)</b>	0.16	0.10863
<b>A (<math>^{\circ}\text{C}^{-1}</math>)</b>	$3.81 \times 10^{-3}$	$3.908 \times 10^{-3}$
<b>B (<math>^{\circ}\text{C}^{-2}</math>)</b>	$-6.02 \times 10^{-7}$	$-5.775 \times 10^{-7}$
<b>C (<math>^{\circ}\text{C}^{-4}</math>)</b>	$-6.0 \times 10^{-12}$	$-4.183 \times 10^{-12}$

Both  $\beta = 0$  and  $C = 0$  for  $T > 0^{\circ}\text{C}$

### ACCURACY VS TEMPERATURE

Temperature ( $^{\circ}\text{C}$ )	Standard $\pm 0.2\%$		Optional $\pm 0.1\%$		
	Tolerance	$\pm \Delta R^*$ ( $\Omega$ )	$\pm \Delta T$ ( $^{\circ}\text{C}$ )	$\pm \Delta R^*$ ( $\Omega$ )	$\pm \Delta T$ ( $^{\circ}\text{C}$ )
-200		6.8	1.6	5.1	1.2
-100		2.9	0.8	2.4	0.6
0		2.0	0.5	1.0	0.3
100		2.9	0.8	2.2	0.6
200		5.6	1.6	4.3	1.2
300		8.2	2.4	6.2	1.8
400		11.0	3.2	8.3	2.5
500		12.5	4.0	9.6	3.0
600		15.1	4.8	10.4	3.3

\* 1000 $\Omega$  RTD. Divide  $\Delta R$  by 10 for 100 $\Omega$  RTD.

### RESISTANCE VS TEMPERATURE CURVE

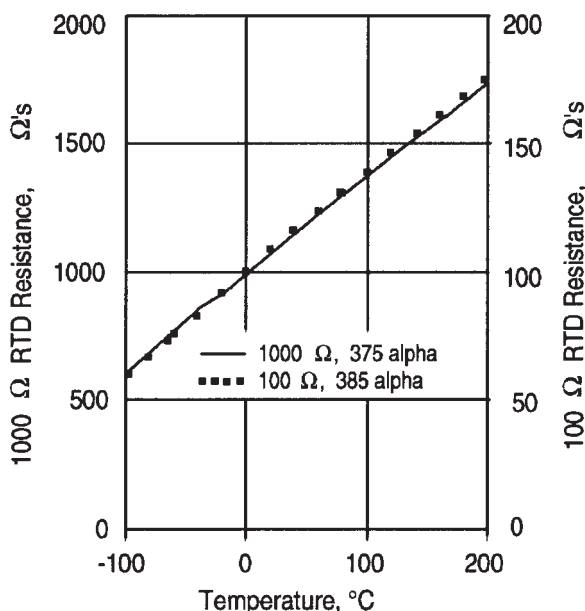

### SPECIFICATIONS

Sensor Type	Thin film platinum RTD: $R_0 = 1000 \Omega @ 0^{\circ}\text{C}$ ; $\alpha = 0.00375 \Omega/\Omega/^{\circ}\text{C}$ $R_0 = 100 \Omega @ 0^{\circ}\text{C}$ ; $\alpha = 0.00385 \Omega/\Omega/^{\circ}\text{C}$
Temperature Range	$-55^{\circ}$ to $+150^{\circ}\text{C}$ ( $-76^{\circ}$ to $+302^{\circ}\text{F}$ )
Temperature Accuracy	$\pm 0.5^{\circ}\text{C}$ or 0.8% of temperature $^{\circ}\text{C}$ ( $R_0 \pm 0.2\%$ trim), whichever is greater $\pm 0.3^{\circ}\text{C}$ or 0.6% of temperature $^{\circ}\text{C}$ ( $R_0 \pm 0.1\%$ trim), whichever is greater (optional)
Base Resistance and Interchangeability, $R_0 \pm \Delta R_0$	$1000 \pm 2 \Omega$ ( $\pm 0.2\%$ ) @ $0^{\circ}\text{C}$ or $100 \pm 0.2 \Omega$ ( $\pm 0.2\%$ ) @ $0^{\circ}\text{C}$ $1000 \pm 1 \Omega$ ( $\pm 0.1\%$ ) @ $0^{\circ}\text{C}$ or $100 \pm 0.1 \Omega$ ( $\pm 0.1\%$ ) @ $0^{\circ}\text{C}$ (optional)
Linearity	$\pm 0.1\%$ of full scale for temperatures spanning $-40^{\circ}$ to $125^{\circ}\text{C}$
Time Constant	<10 seconds in air at 10 ft/sec
Operating Current	2 mA maximum for self heating errors of $< 1^{\circ}\text{C}$ ; 1 mA recommended
Stability	$< 0.25^{\circ}\text{C}/\text{year}$ ; $0.05^{\circ}\text{C}$ per 5 years in occupied environments
Self Heating	$< 15\text{mW}/^{\circ}\text{C}$ typical
Insulation Resistance	$> 50 \text{M}\Omega @ 50 \text{VDC} @ 25^{\circ}\text{C}$
Construction	Plastic case, PLASKON 3300SH
Lead Material	Copper alloy 194 solder dipped tin silver

## Looking for pricing, stock, or lifecycle information?

Click below to explore more details on WIN SOURCE:

 [View HEL-776-A-U-1 on WIN SOURCE](#)

 [Honeywell Information](#)

## Optimize Your Supply Chain with WIN SOURCE Solutions

-  Global Sourcing Solution
-  Obsolete Management
-  Cost Control Management
-  Shortage Management
-  Alternative Solution
-  Excess Inventory Management