



**THE DATASHEET OF  
74AHC164T14-13**



## Description

The 74AHC164 is a serial input 8-bit edge-triggered shift register that has outputs from each of eight stages.

### SERIAL DATA INPUT PINS

The serial input data is entered at pin SDA or pin SDB as these are logically ANDED. Either input could be used as an active HIGH enable with data entry on the other pin. If a single input is desired, the pins can be tied together or the unused input can be tied HIGH.

### DATA ENTRY

Data is shifted into Q0 from the serial input pins on each LOW to HIGH transition of the CP pin. Also during the CP edge the data is transferred from each Qn to Qn+1. The serial data on pins DSA and DSB must be stable before and after the CP rising edge to meet the set-up and hold timing requirements.

### RESET

When asserted LOW the Master Reset ( $\overline{MR}$ ) pin sets all Qn to LOW. This action does not depend on the condition of serial input or clock pins. The  $\overline{MR}$  must be asserted HIGH for a recovery time before the next CP positive edge pulse.

## Features

- Wide Supply Voltage Range from 2.0V to 5.5V
- Sinks or Sources 8mA at  $V_{CC} = 4.5V$
- CMOS Low Power Consumption
- Schmitt Trigger Action at All Inputs
- ESD Protection Exceeds JESD 22
  - 200-V Machine Model (A115)
  - 2000-V Human Body Model (A114)
  - Exceeds 1000-V Charged Device Model (C101)
- Range of Package Options SO-14 and TSSOP-14
- **Totally Lead-Free & Fully RoHS Compliant (Notes 1 & 2)**
- **Halogen and Antimony Free. "Green" Device (Note 3)**

Notes:

1. No purposely added lead. Fully EU Directive 2002/95/EC (RoHS) & 2011/65/EU (RoHS 2) compliant.
2. See [http://www.diodes.com/quality/lead\\_free.html](http://www.diodes.com/quality/lead_free.html) for more information about Diodes Incorporated's definitions of Halogen- and Antimony-free, "Green" and Lead-free.
3. Halogen- and Antimony-free "Green" products are defined as those which contain <900ppm bromine, <900ppm chlorine (<1500ppm total Br + Cl) and <1000ppm antimony compounds.

**Device ordering information is on page 7**

## Pin Assignments

(Top View)

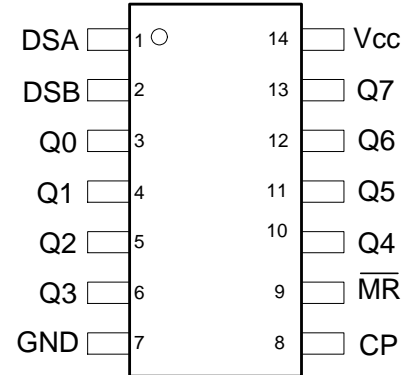

**SO-14 / TSSOP-14 / PDIP-14**

## Applications

- General Purpose Logic
- Wide Array of Products Such as:
  - PCs, Networking, Notebooks, Netbooks
  - Computer Peripherals, Hard Drives, CD/DVD ROMs
  - TVs, DVDs, DVRs, Set-Top Boxes

## Pin Descriptions

Pin Number	Pin Name	Function
1	DSA	Serial Data Input
2	DSB	Serial Data Input
3	Q0	Data Output
4	Q1	Data Output
5	Q2	Data Output
6	Q3	Data Output
7	GND	Ground
8	CP	Clock Pulse –Positive Edge Triggered
9	$\overline{\text{MR}}$	Master Reset - Asynchronous
10	Q4	Data Output
11	Q5	Data Output
12	Q6	Data Output
13	Q7	Data Output
14	V <sub>CC</sub>	Supply Voltage

## Function Table (Note 4)

Mode	Input				Output	
	$\overline{\text{MR}}$	CP	DSA	DSB	Q0	Q1-Q7
Reset	L	X	X	X	L	L
Shift	H	↑	L	X	L	Q <sub>n</sub> ←Q <sub>n-1</sub> (n= 1 to7)
	H	↑	X	L	L	Q <sub>n</sub> ←Q <sub>n-1</sub> (n= 1 to7)
	H	↑	H	H	H	Q <sub>n</sub> ←Q <sub>n-1</sub> (n= 1 to7)

Note: 4. Signals asserted on DSA and DSB must be in place longer than T<sub>su</sub> (set up time) before CP occurs and remain in place T<sub>hold</sub> (hold time) after CP.

**Logic Diagram**

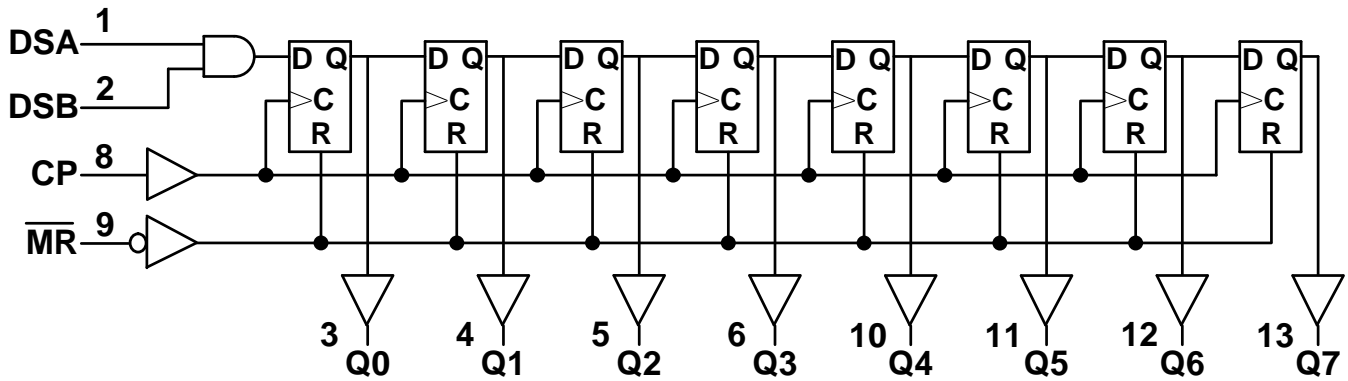

**Timing Diagram**

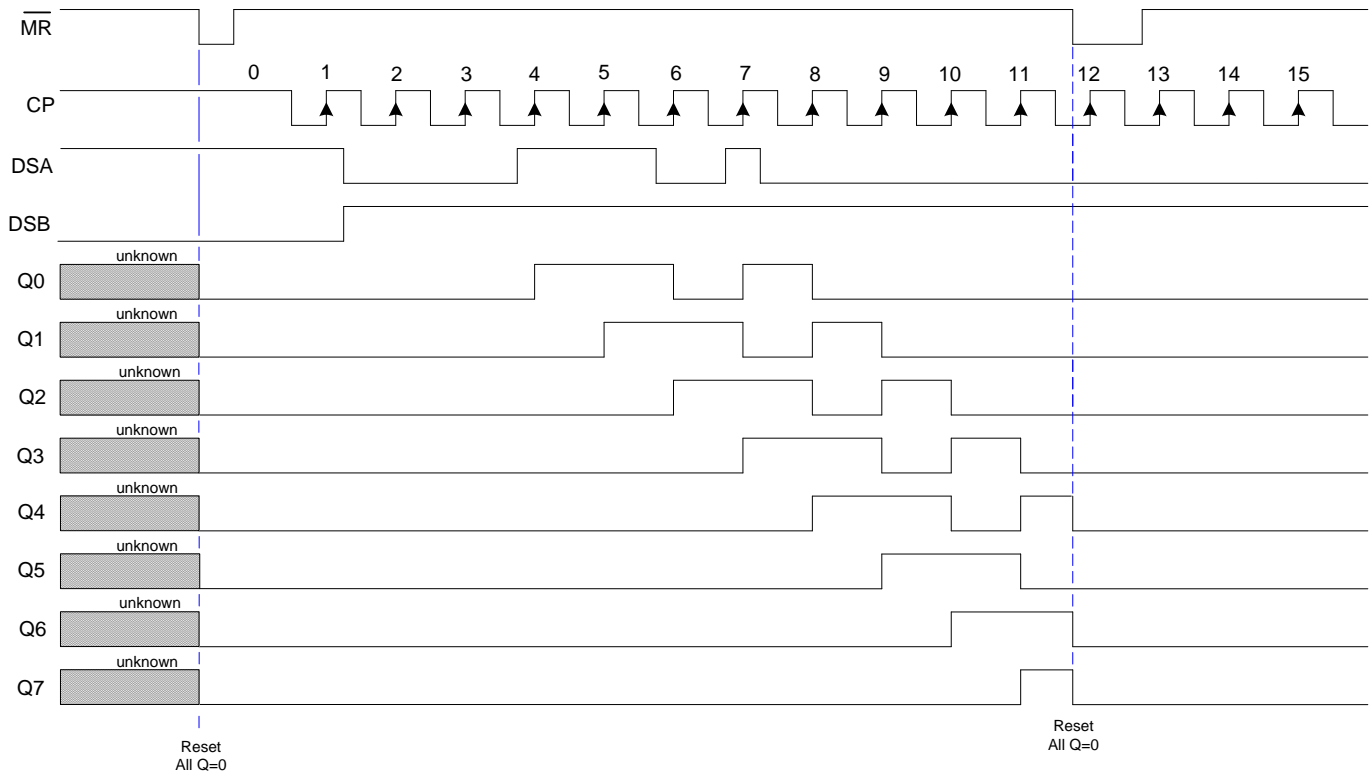

- Notes:
5. All Q values are reset to LOW when  $\overline{MR}$  goes low.  $\overline{MR}$  is asynchronous and overrides all other signals.
  6. Serial data supplied at DSA and DSB is ANDED and transferred to Q0 on positive edge of CP.

### Absolute Maximum Ratings (Note 7) ( $T_A = +25^\circ\text{C}$ , unless otherwise specified.)

Symbol	Description	Rating	Unit
ESD HBM	Human Body Model ESD Protection	2	kV
ESD CDM	Charged Device Model ESD Protection	1	kV
ESD MM	Machine Model ESD Protection	200	V
$V_{CC}$	Supply Voltage Range	-0.5 to +7.0	V
$V_I$	Input Voltage Range (Note 8)	-0.5 to +7.0	V
$I_{IK}$	Input Clamp Current $V_I < -0.5\text{V}$	-20	mA
$I_{OK}$	Output Clamp Current $V_O < -0.5\text{V}$ or $V_O > V_{CC} + 0.5\text{V}$	$\pm 20$	mA
$I_O$	Continuous Output Current $-0.5\text{V} < V_O < V_{CC} + 0.5\text{V}$	$\pm 25$	mA
$I_{CC}$	Continuous Current Through $V_{CC}$	75	mA
$I_{GND}$	Continuous Current Through GND	-75	mA
$T_J$	Operating Junction Temperature	-40 to +150	$^\circ\text{C}$
$T_{STG}$	Storage Temperature	-65 to +150	$^\circ\text{C}$
$P_{TOT}$	Total Power Dissipation	500	mW

Notes: 7. Stresses beyond the absolute maximum may result in immediate failure or reduced reliability. These are stress values and device operation should be within recommend values.  
 8. Input Voltage cannot exceed  $V_{CC}$  to the extent the Maximum clamp current is exceeded.

### Recommended Operating Conditions (Note 9) ( $T_A = +25^\circ\text{C}$ , unless otherwise specified.)

Symbol	Parameter	Conditions	Min	Max	Unit
$V_{CC}$	Supply Voltage	-	2.0	5.5	V
$V_I$	Input Voltage	-	0	5.5	V
$V_O$	Output Voltage	-	0	$V_{CC}$	V
$\Delta t/\Delta V$	Input Transition Rise or Fall Rate	$V_{CC} = 3.0\text{V}$ to $3.6\text{V}$	-	100	ns/V
		$V_{CC} = 4.5\text{V}$ to $5.5\text{V}$	-	20	
$T_A$	Operating Free-Air Temperature	-	-40	+125	$^\circ\text{C}$

Note: 9. Unused inputs should be held at  $V_{CC}$  or Ground.

**Electrical Characteristics** ( $T_A = +25^\circ\text{C}$ , unless otherwise specified.)

Symbol	Parameter	Test Conditions	V <sub>CC</sub>	T <sub>A</sub> = +25°C			T <sub>A</sub> = -40°C to +85°C		T <sub>A</sub> = -40°C to +125°C		Unit	
				Min.	Typ.	Max.	Min.	Max.	Min.	Max.		
V <sub>IH</sub>	High-Level Input Voltage	-	2.0V	1.5	-	-	1.5	-	1.5	-	V	
			3.0V	2.1	-	-	2.1	-	2.1	-		
			5.5V	3.85	-	-	3.85	-	3.85	-		
V <sub>IL</sub>	Low-Level Input Voltage	-	2.0V	-	-	0.5	-	0.5	-	0.5	V	
			3.0V	-	-	0.9	-	0.9	-	0.9		
			5.5V	-	-	1.65	-	1.65	-	1.65		
V <sub>OH</sub>	High-Level Output Voltage	-	I <sub>OH</sub> = -50μA	2.0V	1.9	2.0	-	1.9	-	1.9	-	V
			I <sub>OH</sub> = -50μA	3.0V	2.9	3.0	-	2.9	-	2.9	-	
			I <sub>OH</sub> = -50μA	4.5V	4.4	4.5	-	4.4	-	4.4	-	
			I <sub>OH</sub> = -4.0mA	3.0V	2.58	-	-	2.48	-	2.40	-	
			I <sub>OH</sub> = -8mA	4.5V	3.94	-	-	3.80	-	3.70	-	
V <sub>OL</sub>	Low-Level Output Voltage	-	I <sub>OL</sub> = 50μA	2.0V	-	0	0.1	-	0.1	-	0.1	V
			I <sub>OL</sub> = 50μA	3.0V	-	0	0.1	-	0.1	-	0.1	
			I <sub>OL</sub> = 50μA	4.5V	-	0	0.1	-	0.1	-	0.1	
			I <sub>OL</sub> = 4mA	3.0V	-	0.15	0.36	-	0.44	-	0.55	
			I <sub>OL</sub> = 8mA	4.5V	-	0.15	0.36	-	0.44	-	0.55	
I <sub>I</sub>	Input Current	V <sub>I</sub> = GND or 5.5V	0V or 5.5V	-	-	±0.1	-	±1	-	±2	μA	
I <sub>CC</sub>	Supply Current	V <sub>I</sub> = GND or V <sub>CC</sub> , I <sub>O</sub> = 0A	5.5V	-	-	4.0	-	40	-	80	μA	

**Switching Characteristics**

Symbol / Parameter	Pins	Test Conditions Figure 1	V <sub>CC</sub>	T <sub>A</sub> = +25°C			-40°C to +85°C		-40°C to +125°C		Unit
				Min	Typ.	Max	Min	Max	Min	Max	
f <sub>MAX</sub> Maximum Frequency	CP	C <sub>L</sub> = 15pF	3.0V to	80	125	-	65	-	50	-	MHz
		C <sub>L</sub> = 50pF	3.6V	50	75	-	45	-	35	-	
		C <sub>L</sub> = 15pF	4.5V to	125	175	-	105	-	85	-	
		C <sub>L</sub> = 50pF	5.0V	85	115	-	75	-	65	-	
t <sub>w</sub> Pulse Width	CP HIGH or LOW	-	3.0V to 3.6V	5.0	-	-	5.0	-	5.0	-	ns
		-	4.5V to 5.0V	5.0	-	-	5.0	-	5.0	-	
	MR LOW	-	3.0V to 3.6V	5.0	-	-	5.0	-	5.0	-	ns
		-	4.5V to 5.0V	5.0	-	-	5.0	-	5.0	-	
t <sub>SU</sub> Set-up Time	DSA or DSB to CP	-	3.0V to 3.6V	5.0	-	-	6.0	-	6.0	-	ns
		-	4.5V to 5.0V	4.5	-	-	4.5	-	4.5	-	
t <sub>H</sub> Hold Time	DSA or	-	3.0V to 3.6V	1.5	-	-	1.5	-	1.5	-	ns
		-	4.5V to 5.0V	2.0	-	-	2.0	-	2.0	-	
t <sub>rec</sub> Recovery Time	MR to CP	-	3.0V to 3.6V	2.5	-	-	2.5	-	2.5	-	ns
		-	4.5V to 5.0V	2.5	-	-	2.5	-	2.5	-	
t <sub>PD</sub> Propagation Delay	CP to Qn	C <sub>L</sub> = 15pF	3.0V to	-	6.5	12.8	1.0	15.0	1.0	16.0	ns
		C <sub>L</sub> = 50pF	3.6V	-	9.3	16.3	1.0	18.5	1.0	20.5	
		C <sub>L</sub> = 15pF	4.5V to	-	4.5	9.0	1.0	10.5	1.0	11.5	
		C <sub>L</sub> = 50pF	5.0V	-	6.4	11.0	1.0	12.5	1.0	14.0	
	MR to Qn	C <sub>L</sub> = 15pF	3.0V to	-	5.3	12.8	1.0	15.0	1.0	16.0	ns
		C <sub>L</sub> = 50pF	3.6V	-	7.6	16.3	1.0	18.5	1.0	20.5	
		C <sub>L</sub> = 15pF	4.5V to	-	4.0	8.6	1.0	10.0	1.0	11.0	
		C <sub>L</sub> = 50pF	5.0V	-	5.8	10.6	1.0	12.0	1.0	13.5	

**Operating Characteristics** (T<sub>A</sub> = +25°C, unless otherwise specified.)

Parameter		Test Conditions	V <sub>CC</sub> = 5.5V		Unit
			Typ	Maximum	
C <sub>pd</sub>	Power Dissipation Capacitance per Gate	f = 1 MHz	51	-	pF
C <sub>I</sub>	Input Capacitance	V <sub>I</sub> = V <sub>CC</sub> or GND	3	10	pF

**Parameter Measurement Information**

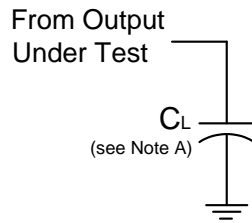

V <sub>CC</sub>	Inputs		V <sub>M</sub>	C <sub>L</sub>
	V <sub>I</sub>	t <sub>r</sub> /t <sub>f</sub>		
3.0V-3.6V	V <sub>CC</sub>	≤3ns	V <sub>CC</sub> /2	15pF,50pF
4.5V-5.5V	V <sub>CC</sub>	≤3ns	V <sub>CC</sub> /2	15pF,50pF

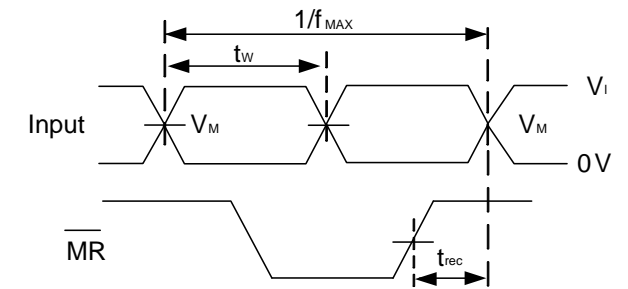

**Voltage Waveform  
Pulse Duration and Recovery Time**

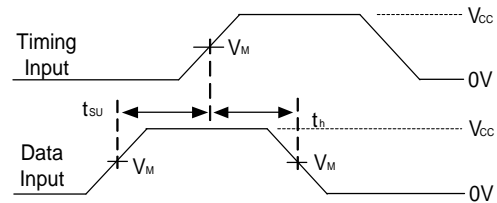

**Voltage Waveform  
Set-up and Hold Times**

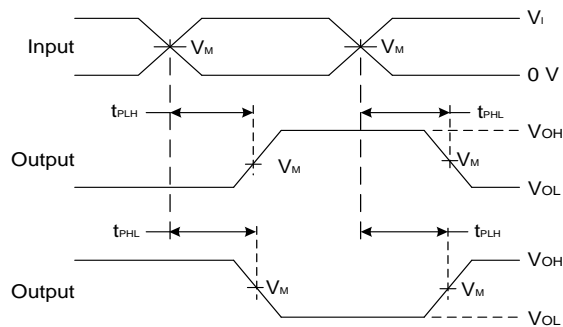

**Voltage Waveform  
Propagation Delay Times  
Inverting and Non Inverting Outputs**

- Notes:
- A. Includes test lead and test apparatus capacitance.
  - B. All pulses are supplied at pulse repetition rate ≤10 MHz.
  - C. Inputs are measured separately one transition per measurement.
  - D. t<sub>PLH</sub> and t<sub>PHL</sub> are the same as t<sub>PD</sub>.

**Figure 1 Load Circuit and Voltage Waveforms**

**Ordering Information**

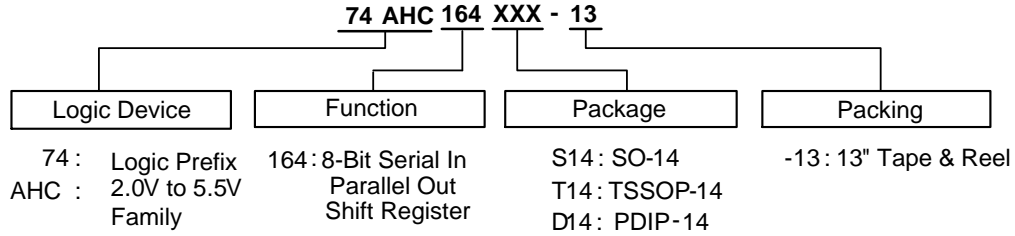

Device	Package Code	Packaging	Packing	
			Quantity	Part Number Suffix
74AHC164S14-13	S14	SO-14	2,500/Tape & Reel	-13
74AHC164T14-13	T14	TSSOP-14	2,500/Tape & Reel	-13
74AHC164D14	D14	PDIP-14	Tube	

**Marking Information**

(1) SO-14, TSSOP-14, PDIP-14

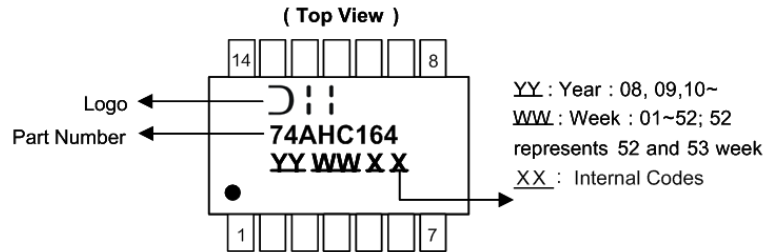

Part Number	Package
74AHC164S14-13	SO-14
74AHC164T14-13	TSSOP-14
74AHC164D14	PDIP-14

**Package Outline Dimensions** (All dimensions in mm.)

Please see AP02002 at <http://www.diodes.com/datasheets/ap02002.pdf> for the latest version.

**Package Type: SO-14**

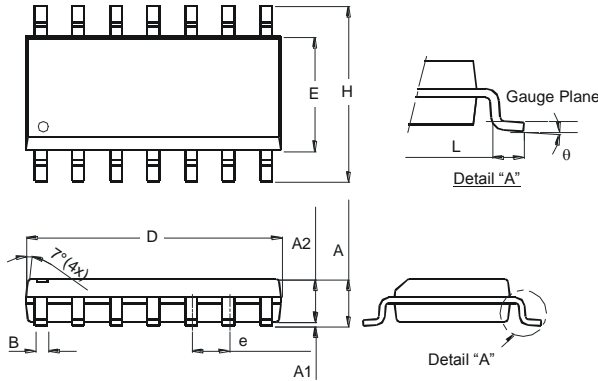

SO-14		
Dim	Min	Max
A	1.47	1.73
A1	0.10	0.25
A2	1.45 Typ	
B	0.33	0.51
D	8.53	8.74
E	3.80	3.99
e	1.27 Typ	
H	5.80	6.20
L	0.38	1.27
θ	0°	8°
All Dimensions in mm		

**Package Type: TSSOP-14**

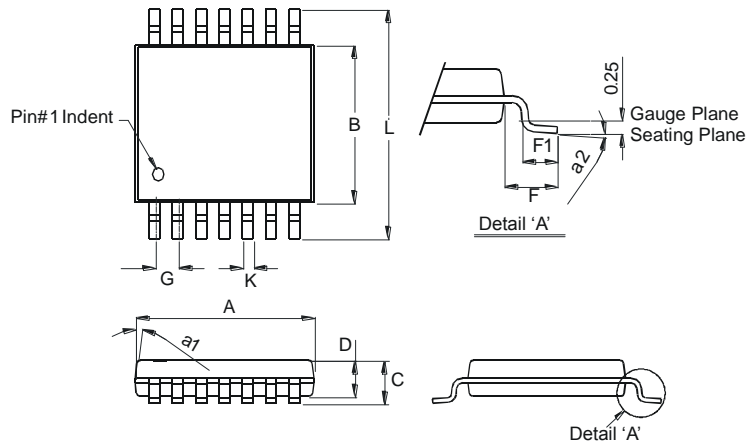

TSSOP-14		
Dim	Min	Max
a1	7° (4X)	
a2	0°	8°
A	4.9	5.10
B	4.30	4.50
C	—	1.2
D	0.8	1.05
F	1.00 Typ	
F1	0.45	0.75
G	0.65 Typ	
K	0.19	0.30
L	6.40 Typ	
All Dimensions in mm		

**Package Type: PDIP-14**

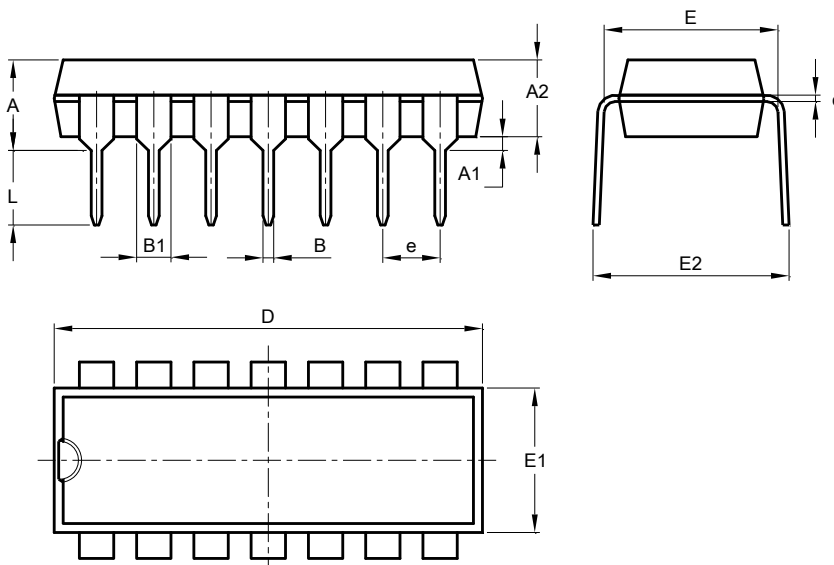

PDIP-14		
Dim	Min	Max
A	3.710	4.310
A1	0.510	-
A2	3.200	3.600
B	0.380	0.570
B1	1.524 (BSC)	
c	0.204	0.360
D	18.800	19.200
E	6.200	6.600
E1	7.320	7.920
E2	8.400	9.000
e	2.540 (BSC)	
L	3.000	3.600
All Dimensions in mm		

**Suggested Pad Layout**

Please see AP02001 at <http://www.diodes.com/datasheets/ap02001.pdf> for the latest version.

**Package Type: SO-14**

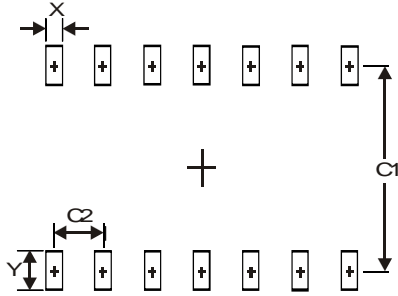

Dimensions	Value (in mm)
X	0.60
Y	1.50
C1	5.4
C2	1.27

**Package Type: TSSOP-14**

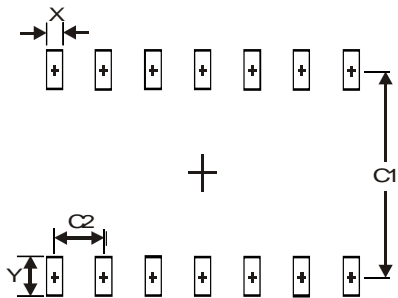

Dimensions	Value (in mm)
X	0.45
Y	1.45
C1	5.9
C2	0.65

**IMPORTANT NOTICE**

DIODES INCORPORATED MAKES NO WARRANTY OF ANY KIND, EXPRESS OR IMPLIED, WITH REGARDS TO THIS DOCUMENT, INCLUDING, BUT NOT LIMITED TO, THE IMPLIED WARRANTIES OF MERCHANTABILITY AND FITNESS FOR A PARTICULAR PURPOSE (AND THEIR EQUIVALENTS UNDER THE LAWS OF ANY JURISDICTION).

Diodes Incorporated and its subsidiaries reserve the right to make modifications, enhancements, improvements, corrections or other changes without further notice to this document and any product described herein. Diodes Incorporated does not assume any liability arising out of the application or use of this document or any product described herein; neither does Diodes Incorporated convey any license under its patent or trademark rights, nor the rights of others. Any Customer or user of this document or products described herein in such applications shall assume all risks of such use and will agree to hold Diodes Incorporated and all the companies whose products are represented on Diodes Incorporated website, harmless against all damages.

Diodes Incorporated does not warrant or accept any liability whatsoever in respect of any products purchased through unauthorized sales channel. Should Customers purchase or use Diodes Incorporated products for any unintended or unauthorized application, Customers shall indemnify and hold Diodes Incorporated and its representatives harmless against all claims, damages, expenses, and attorney fees arising out of, directly or indirectly, any claim of personal injury or death associated with such unintended or unauthorized application.

Products described herein may be covered by one or more United States, international or foreign patents pending. Product names and markings noted herein may also be covered by one or more United States, international or foreign trademarks.

This document is written in English but may be translated into multiple languages for reference. Only the English version of this document is the final and determinative format released by Diodes Incorporated.

**LIFE SUPPORT**

Diodes Incorporated products are specifically not authorized for use as critical components in life support devices or systems without the express written approval of the Chief Executive Officer of Diodes Incorporated. As used herein:

A. Life support devices or systems are devices or systems which:

1. are intended to implant into the body, or
2. support or sustain life and whose failure to perform when properly used in accordance with instructions for use provided in the labeling can be reasonably expected to result in significant injury to the user.

B. A critical component is any component in a life support device or system whose failure to perform can be reasonably expected to cause the failure of the life support device or to affect its safety or effectiveness.

Customers represent that they have all necessary expertise in the safety and regulatory ramifications of their life support devices or systems, and acknowledge and agree that they are solely responsible for all legal, regulatory and safety-related requirements concerning their products and any use of Diodes Incorporated products in such safety-critical, life support devices or systems, notwithstanding any devices- or systems-related information or support that may be provided by Diodes Incorporated. Further, Customers must fully indemnify Diodes Incorporated and its representatives against any damages arising out of the use of Diodes Incorporated products in such safety-critical, life support devices or systems.

Copyright © 2015, Diodes Incorporated

[www.diodes.com](http://www.diodes.com)

## Looking for pricing, stock, or lifecycle information?

Click below to explore more details on WIN SOURCE:

- ⊖ [View 74AHC164T14-13 on WIN SOURCE](#)
- ⊖ [Diodes Incorporated Information](#)

## Optimize Your Supply Chain with WIN SOURCE Solutions

- ✓ Global Sourcing Solution
- ✓ Obsolete Management
- ✓ Cost Control Management
- ✓ Shortage Management
- ✓ Alternative Solution
- ✓ Excess Inventory Management