



**THE DATASHEET OF
FX16F-21P-HC**



0.5mm pitch, Next Generation High Speed Wire-to-Board Connectors

FX16 Series



"V-by-One® HS" is a trade mark of Thine Electronics, Inc.

■ Features

1. Supports next-generation high speed transmissions

FX16 Series supports next-generation high-speed signals including signal transmission of up to 6Gbps. The FX16 series delivers exceptional impedance-matching, even at sharp signal rise times of $T_r=50ps$ (10 - 90%). (Fig.1)

2. V-by-One® HS compatible connector

The FX16 Series connector is recommended by Thine Electronics, Inc. for their V-By-One® HS next-generation panel interface, due to the connector's outstanding signal integrity performance at 3.75Gb/s - the top data rate of the interface. As shown in Fig.2 on the right, the eye pattern remains wide open at 3.75Gbps. (Please refer to the transmission property data shown on Page 4.)

3. A patented flip-lock harness simplifies FFC applications.

We have incorporated our proprietary patented flip-lock design that greatly simplifies FFC assembly by eliminating the need for costly cable soldering (Fig.3).

4. Vertical cable plug

The vertical plug mating style simplifies the assembly process. In addition, it offers a lower profile by limiting the mated height to only 8mm (Fig.4).

5. Multiple variations of plug style, cable type and number of positions available

The series features a common plug for shielded FFC and micro coaxial cable. Available plug variations include right-angle, vertical style for batch harness assembly and direct plugin styles. Multiple position sizes are available (please see page 5 for variations).

6. RoHS compliant

All materials and substances used to produce these parts fully comply with RoHS standards.

Supports next generation high-speed transmission

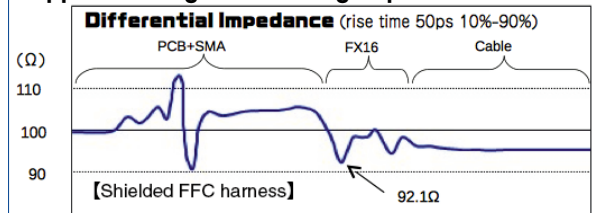

Fig.1

V-by-One® HS compatible connector

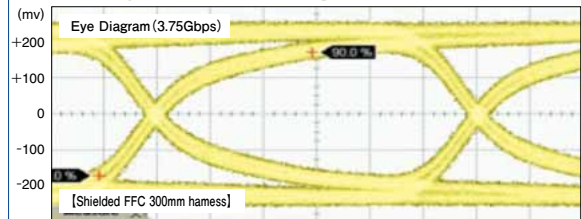

Fig.2

Simplified FFC harness assembly with a flip-lock system

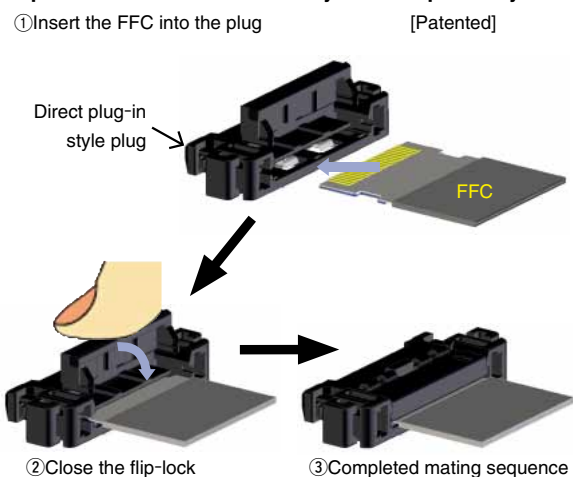

Fig.3

Vertical mating, horizontal wiring

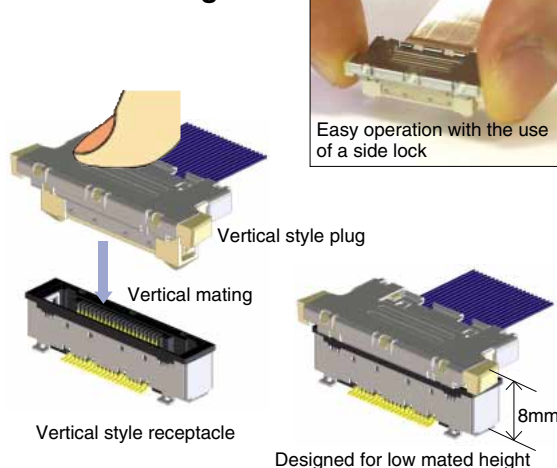

Fig.4

Product Specifications

Ratings	Current Rating 0.5A	Voltage Rating AC60V
	Operating Temperature Range : -55 to 85°C (Note 1) (Note 2)	Operating Humidity Range : relative humidity of no more than 85% (Note 2) (Note 4)
	Storage Temperature Range : -10 to 60°C (Note 3)	Operating Humidity Range : relative humidity of no more than 70% (Note 3) (Note 4)

Items	Specifications	Conditions
1.Contact resistance	80mΩ max (Note 5)	Measured at 1mA
2.Insulation resistance	500MΩ minimum	Measured at DC 100V
3.Withstand voltage	No flashover or breakdown	AC 200V is applied for 1 minute
4.Overall push-pull force	Inserting force (0.5 × number of pos.) : no more than 1N Extracting force (0.05 × number of pos.) : no less than 1N	Measured by using applicable connectors
5.Durability	Contact resistance : variation from the initial state : no more than 20mΩ	50 mating cycles
6. Vibration	No electrical discontinuity of 1μ or greater	Frequency 10 - 55Hz, half amplitude 0.75mm, 2 hours for 3 axial directions
7.Shock	No electrical discontinuity of 1μ or greater	Accelerated velocity : 490m/s ² , for 11ms, half-sine in 3 directions, 3 times for each of the three directions (axes)
8. Humidity resistance	Contact resistance : variation from the initial state : 20mΩ max Insulation resistance : minimum of 500MΩ	96 hours at 40°C temperature and the humidity range from 90 to 95%
9. Temperature cycles	Contact resistance : variation from the initial state : 20mΩ max Insulation resistance : 500MΩ min	Temperature : -55 → 5 to 35 → 85 → 5 to 35°C 5 cycles of the testing time period of 30 → 5 → 30 → 5 minutes

Note 1 : Includes temperature rise caused by current flow.

Note 2 : The operating temperature range when the operating humidity is above 80% shall be -55 to 40°C.

Note 3 : The term "storage" refers to the long-term storage condition of unused products before PCB mounting.

Note 4 : No condensation allowed.

Note 5 : The conductor resistance of connected cables is not included.

Materials / Finish

●Receptacle

Part	Materials	Finish	Remarks
Insulator	FX16 : LCP resin FX16M2 : Polyamide resin	Black color	UL94V-0
Contact	Copper alloy	Gold plating	—————
Shell	Copper alloy	Pure tin-plating	—————

●Plug

Part	Materials	Finish	Remarks
Insulator	FX16-SD/SDL : Polyamide resin FX16F-HC : PC resin FX16M2-HC : PBT resin	FX16-SD/SDL : Beige color FX16F-HC : Black color FX16M2-HC : Black color	UL94V-0
Contact (FX16-SD/SDL only)	Copper alloy	Contact interface area : gold plating Termination area : pure tin-plating	—————
Shell	FX16-SD/SDL : Stainless steel FX16F-HC : Stainless steel FX16M2-HC : Copper alloy	FX16-SD/SDL : Nickel plating FX16F-HC : Nickel plating FX16M2-HC : Pure tin-plating	—————

●Accessories

Part	Materials	Finish	Remarks
Cover shell	Stainless steel	—————	—————

Product Number Structure

Refer to the chart below when determining the product specifications from the product number.
Please select from the product numbers listed in this catalog when placing orders.

●Receptacle

FX 16 M2 - 51 S - 0.5 SH ()**

① ② ③ ④ ⑤ ⑥ ⑦ ⑩

●Plug

FX 16 M2 - 51 P - HC

① ② ③ ④ ⑤ ⑧

●Accessories (Cover shell)

FX 16 - 31 P - GND

① ② ④ ⑤ ⑨

① Series Name	: FX
② Series No.	: 16
③ Shape designation	None/F/M2 : Hirose control identification code
④ Number of positions	
⑤ Contact type	S : female contact P : male contact
⑥ Contact pitch	0.5 : 0.5mm pitch None : No contact
⑦ Product type (Receptacle)	SH : right-angle type SV : vertical type
⑧ Product type(Plug)	SD : Right-angle batch cable assembly type (Micro coaxial cable) SDL : Vertical batch cable assembly type (Micro coaxial cable) HC : FFC holder type
⑨ Product type (Accessories)	GND : Right-angle type cover for micro coaxial cables GNDL : Vertical type cover for micro coaxial cables
⑩ Packaging	None : embossed tape package (1,000pcs/reel) (30) : embossed tape package (100pcs/reel)

Transmission properties

Differential impedance [Rise time: Tr=100ps]

A differential impedance of $100\Omega \pm 10\%$ is maintained at signal rise time of 100ps. (*Notes), This specification is met by way of an impedance-matching design based on SI simulation.

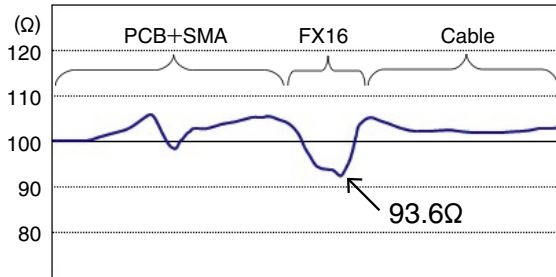
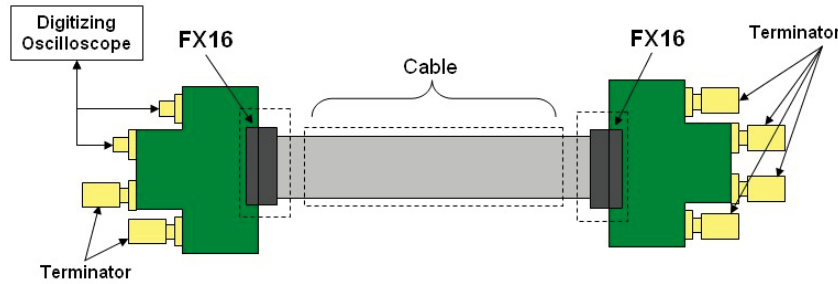

[Micro coax cable harness product]

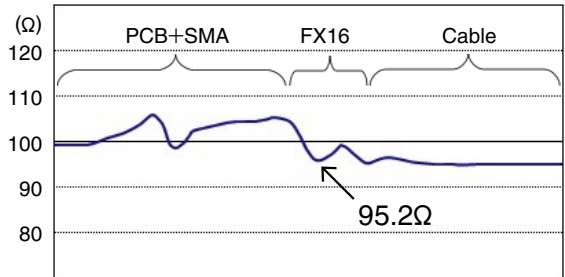

[Shielded FFC type harness product]

Eye diagram

The FX16 Series connector shows outstanding performance at 3.75Gbps, the maximum speed of V-By-One® HS developed by Thine Electronics, Inc.

Testing with actual V-by-One® HS signals shows that the eye pattern is wide open at these signal speeds. (*Notes)

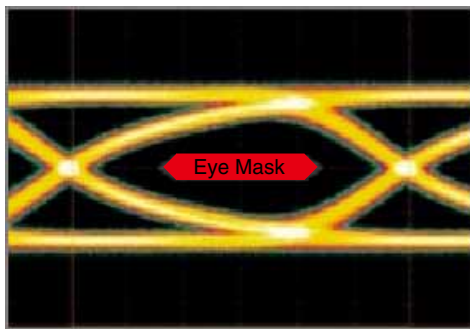
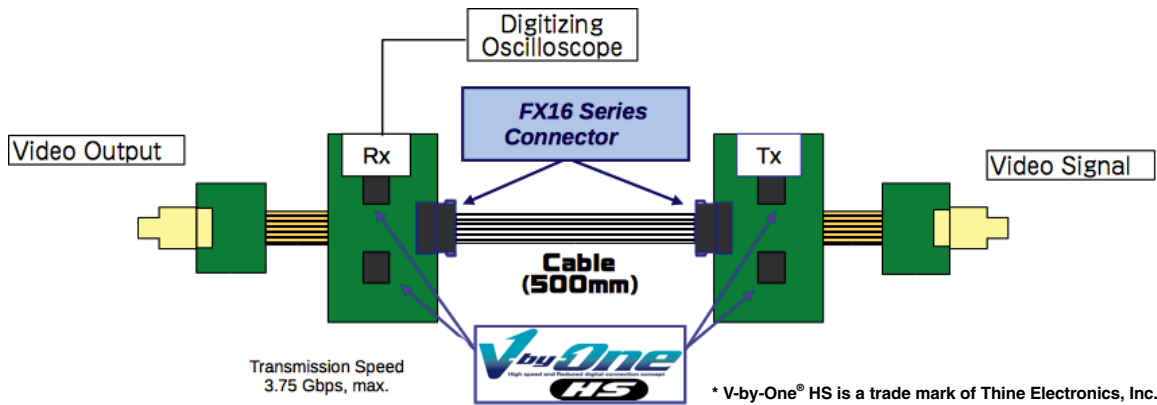

[Micro coax cable harness 500mm product]

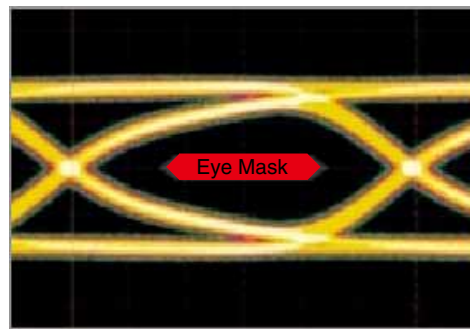

[Shielded FFC type harness 500mm product]

*Note) Results may vary depending on the length and properties of the cables used.

◆ Diagram of FX16 Series variations and mating table

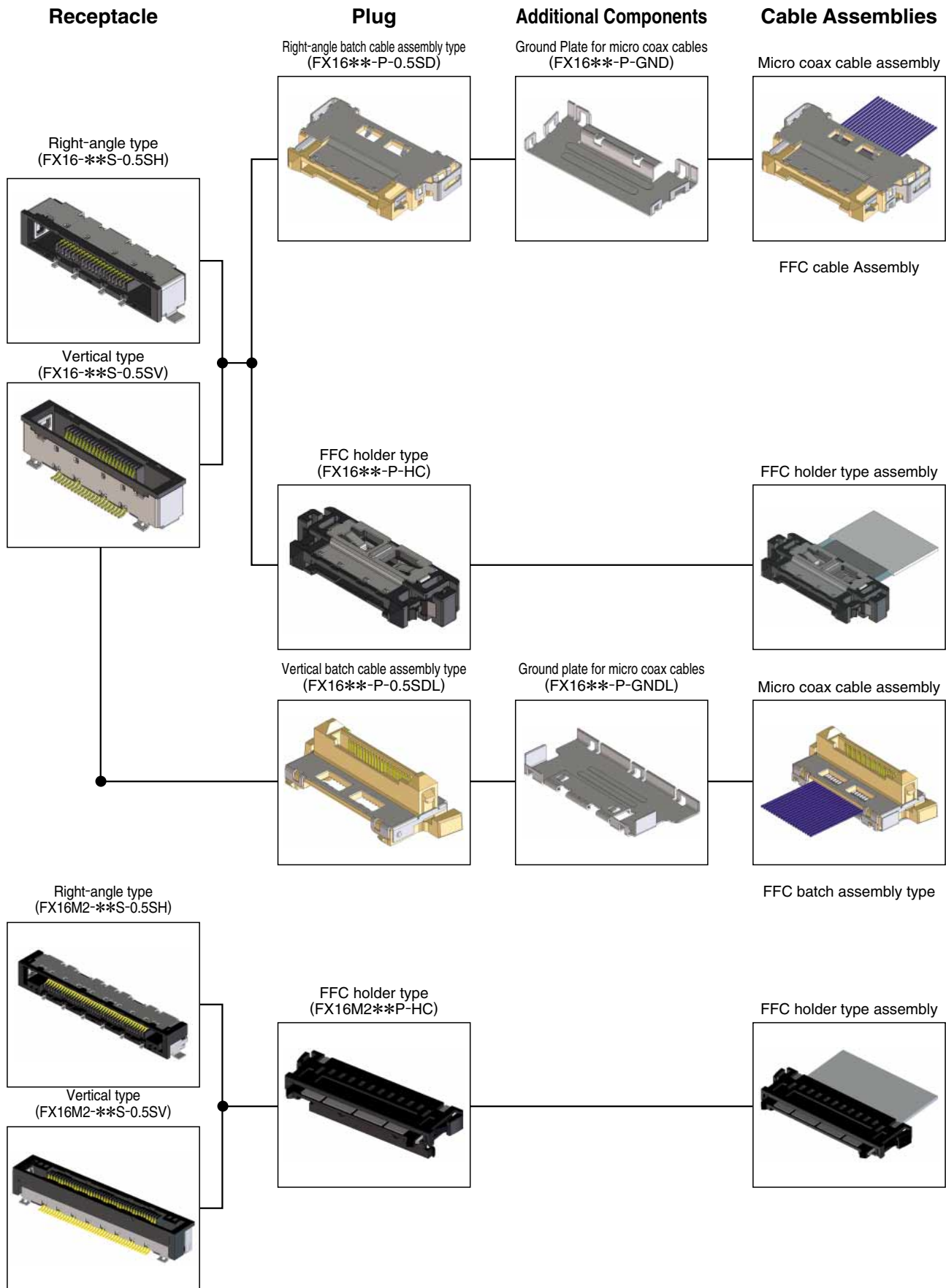

Jun. 1. 2024 Copyright 2024 HIROSE ELECTRIC CO., LTD. All Rights Reserved.

◆ FX16 Series mating dimensions (Reference dimensions)

Receptacle

Plug

Mated condition

Right-angle, PCB mount type
(FX16-**-S-0.5SH)

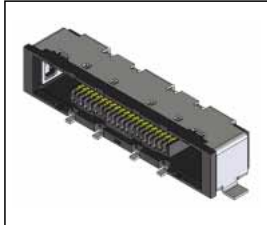

Right-angle type micro coaxial cable harness
(FX16**-P-SD)

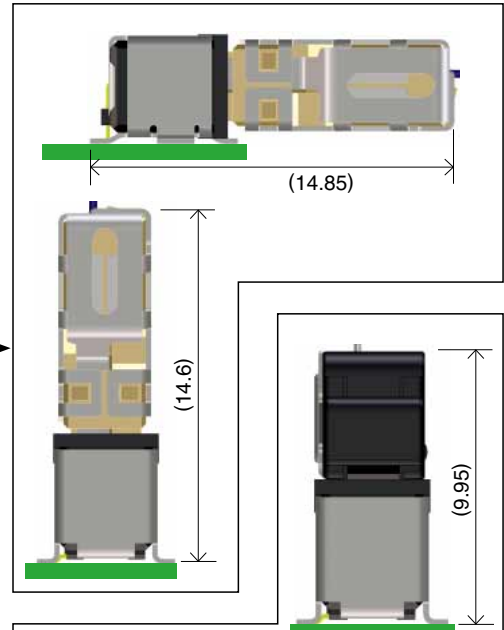

Vertical, PCB mount type
(FX16-**-S-0.5SV)



Holder FFC type assembly
(FX16**-P-HC)

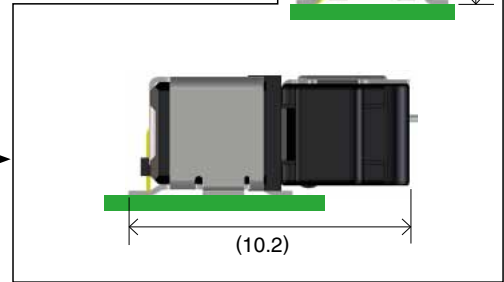
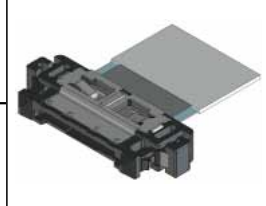

Vertical type micro coaxial cable harness
(FX16**-P-SDL)

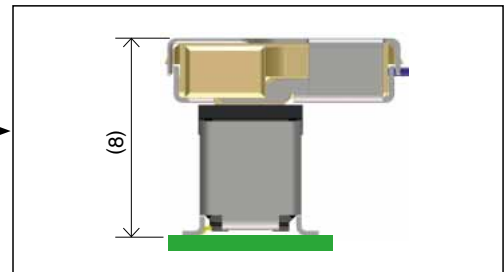
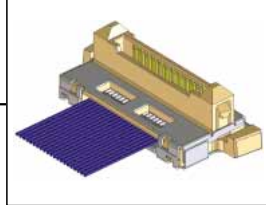

Right-angle, PCB mount type
(FX16M2-**-S-0.5SH)



Holder FFC type assembly
(FX16M2-**-P-HC)

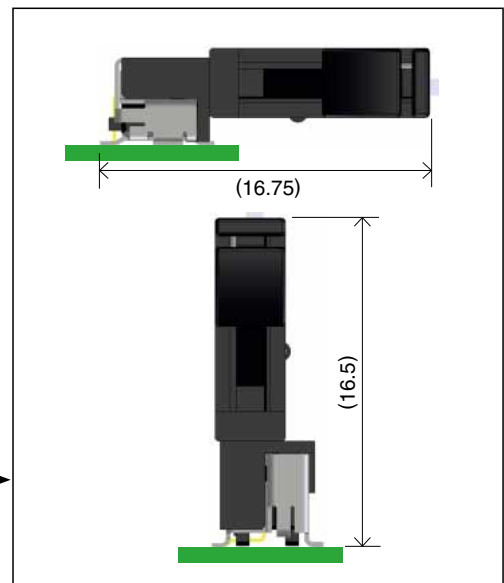
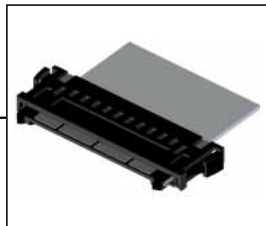

(Unit : mm)

■ Receptacle

● Right-angle type (FX16-**-S-0.5SH)

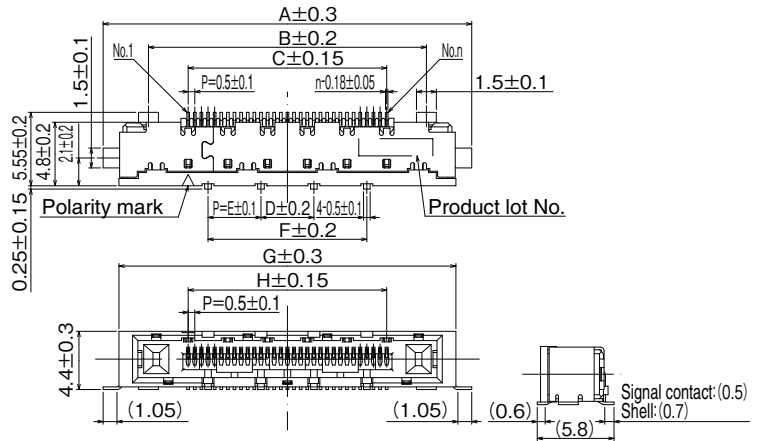
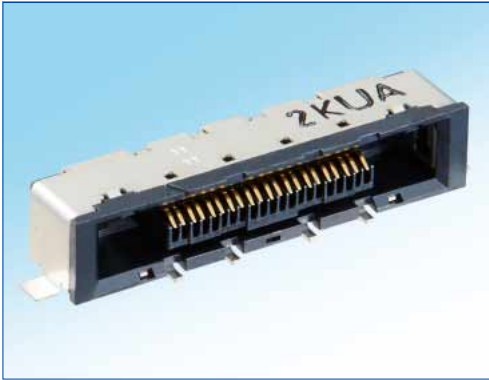

● Right-angle type (FX16M2-**-S-0.5SH)

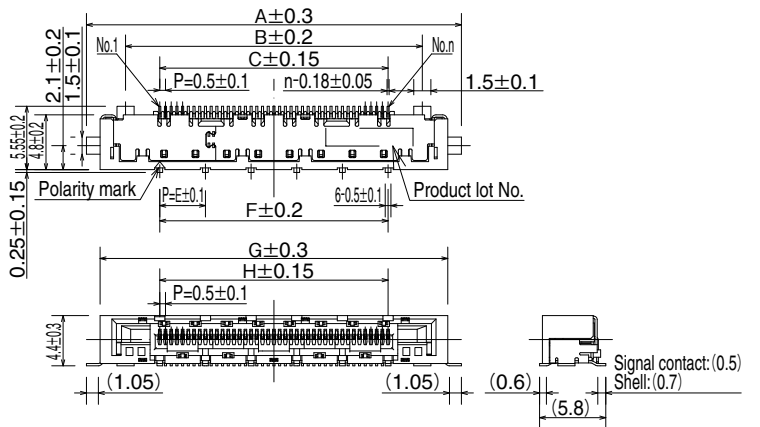
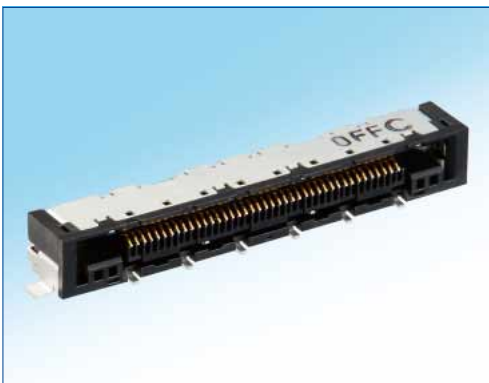

◆ Recommended PCB layout (Metal mask dimension)

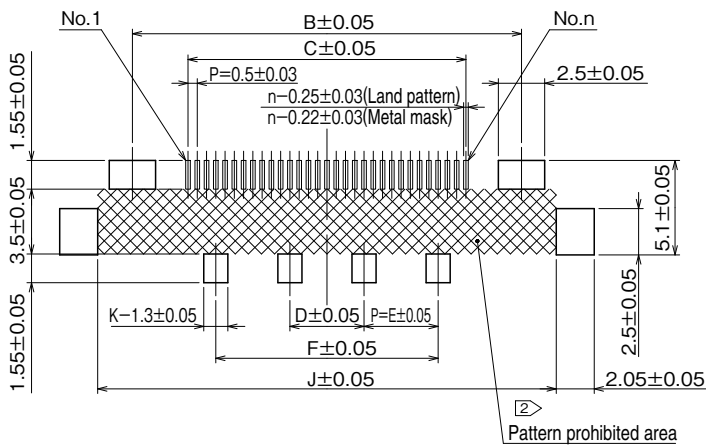

Notes:

- 1 The co-planarity of the contact and shell of this product is 0.1mm max.
- 2 Insulation measures such as the pattern prohibited area or resist processing are required in the area identified by  inside the land pattern.
- 3 () is a reference dimension.
- 4 During the manufacturing process, products may incur some minor cosmetic damage (dents/scratches), but this will not affect their performance.
- 5 This product is delivered in an embossed reel packaging; the packaged quantity for one reel is 1,000 pieces for standard articles (00) and 100 pieces for the specification of (30).

Unit : mm

Part No.	HRS No.	No. of Contacts (n)	A	B	C	D	E	F	G	H	J	K	RoHS
FX16-21S-0.5SH(**)	575-3411-5 **	21	22.85	16	10	4	—	10	20.46	10	19.75	4	○
FX16-31S-0.5SH(**)	575-3412-8 **	31	27.85	21	15	—	4	12	25.46	15	24.75	4	
FX16M2-41S-0.5SH(**)	575-3003-9 **	41	32.85	26	20	—	4	20	30.46	20	29.75	6	
FX16M2-51S-0.5SH(**)	575-3004-1 **	51	37.85	31	25	—	5	25	35.46	25	34.75	6	

(00) : Embossed package (1,000pcs/reel), (30) : Embossed package (100pcs/reel)

●Vertical type (FX16-**S-0.5SV)

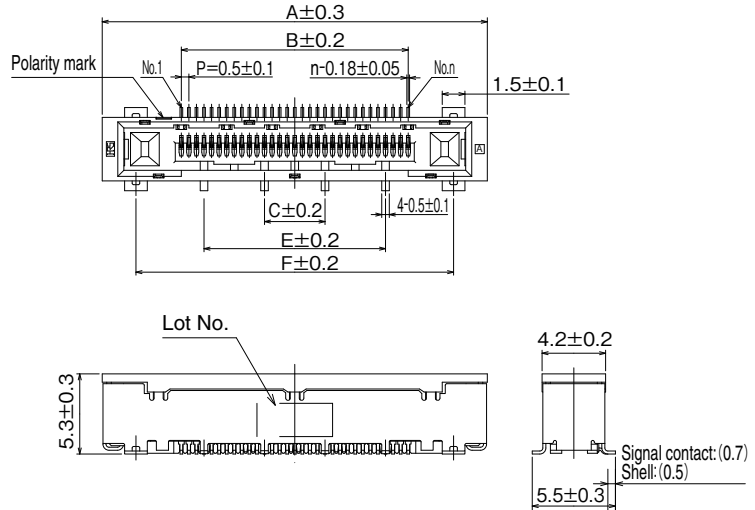

●Vertical type (FX16M2-**S-0.5SV)

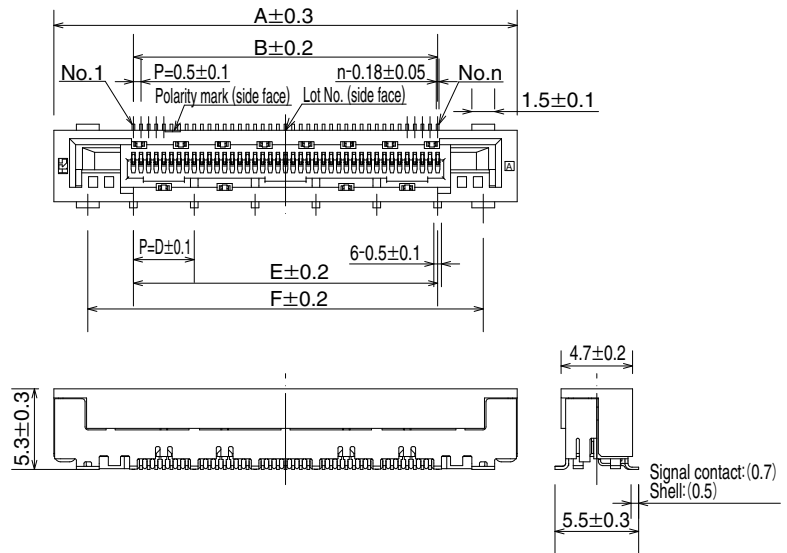

◆Recommended PCB layout (Metal mask dimension)

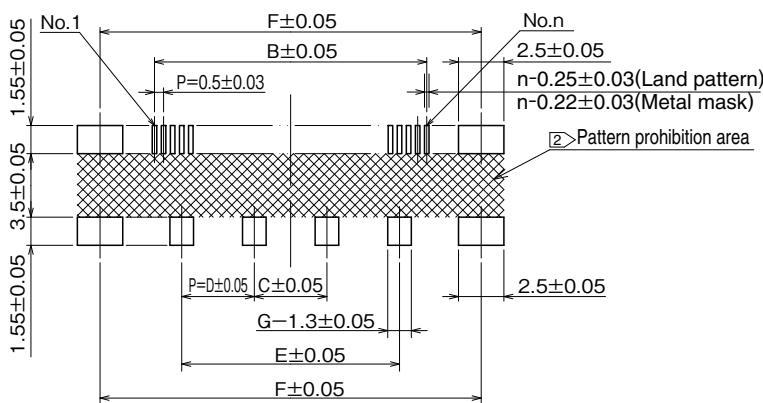

Notes :

- 1 The co-planarity of the contact and shell should measure no more than 0.1 (mm).
- 2 Insulation measures such as the pattern prohibited area or resist processing are required in the area identified by inside the land pattern.
- 3 () is a reference dimension.
- 4 During the manufacturing process, products may incur some minor cosmetic damage (dents/scratches), but this will not affect their performance.
- 5 This product is delivered in an embossed package; the packaged quantity in one reel is 1,000 pieces for standard articles (00) and 100 pieces for the specification of (30).

Unit : mm

Part No.	HRS No.	No. of Contacts (n)	A	B	C	D	E	F	G	RoHS
FX16-21S-0.5SV(**)	575-3401-1 **	21	20.46	10	4	-	10	16	4	○
FX16-31S-0.5SV(**)	575-3402-4 **	31	25.46	15	-	4	12	21		
FX16M2-41S-0.5SV(**)	575-3002-6 **	41	30.46	20	-		20	26	6	

(00) : Embossed package (1,000pcs/reel), (30) : Embossed package (100pcs/reel)

◆ Emboss carrier dimensions (receptacles only)

● Horizontal type (FX16-***S-0.5SH / FX16M2-***S-0.5SH)

Unit : mm

Part No.	HRS No.	No. of Contacts (n)	A	B	C	D	W
FX16-21S-0.5SH(**)	575-3411-5 **	21	44	40.4	20.2	23.76	44.5
FX16-31S-0.5SH(**)	575-3412-8 **	31				28.76	
FX16M2-41S-0.5SH(**)	575-3003-9 **	41	56	52.4	26.2	33.76	56.5
FX16M2-51S-0.5SH(**)	575-3004-1 **	51				38.76	

(00) : Embossed package (1,000pcs/reel), (30) : Embossed package (100pcs/reel)

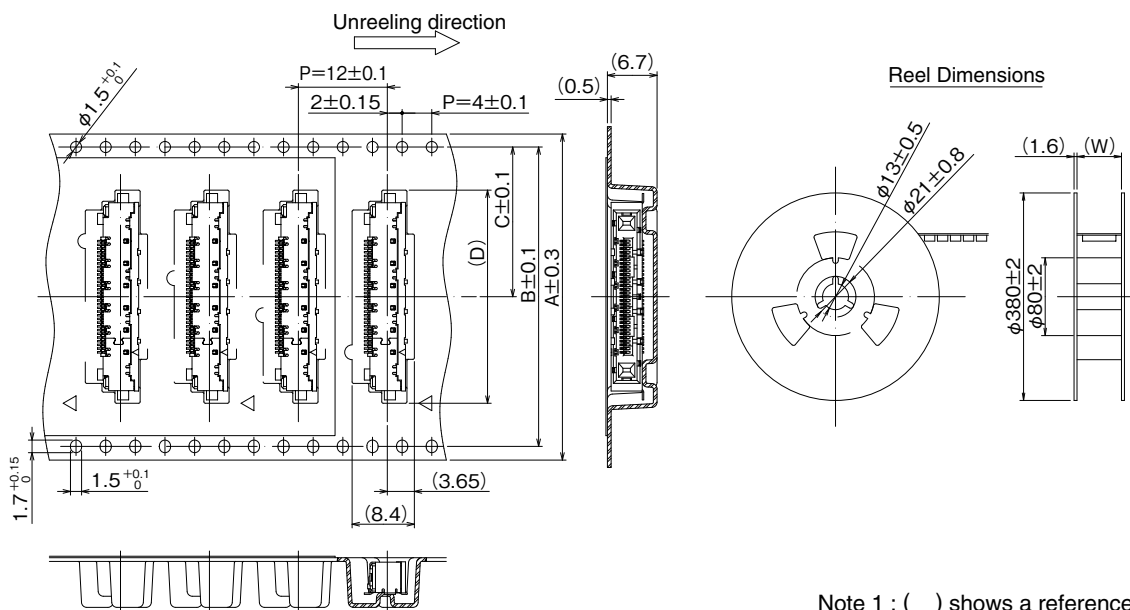

Note 1 : () shows a reference dimension.

● Vertical type (FX16-***S-0.5SV / FX16M2-***S-0.5SV)

Unit : mm

Part No.	HRS No.	No. of Contacts (n)	A	B	C	D	E	W
FX16-21S-0.5SV(**)	575-3401-1 **	21	44	40.4	20.2	20.57	6.9	44.5
FX16-31S-0.5SV(**)	575-3402-4 **	31				25.57		
FX16M2-41S-0.5SV(**)	575-3002-6 **	41				30.57	7	

(00) : Embossed package (1,000pcs/reel), (30) : Embossed package (100pcs/reel)

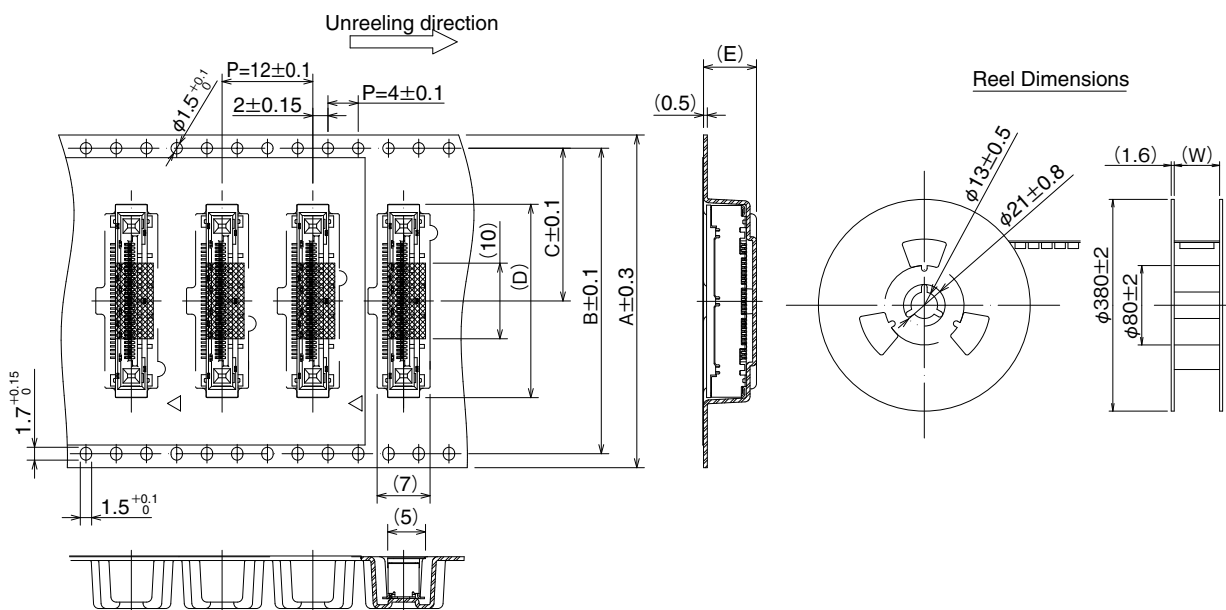

Note 1 : () shows a reference dimension.

◆ Recommended Temperature Profile

This temperature profile is a reference based on the following conditions. Since your actual conditions may vary, please check your process before mounting the connectors.

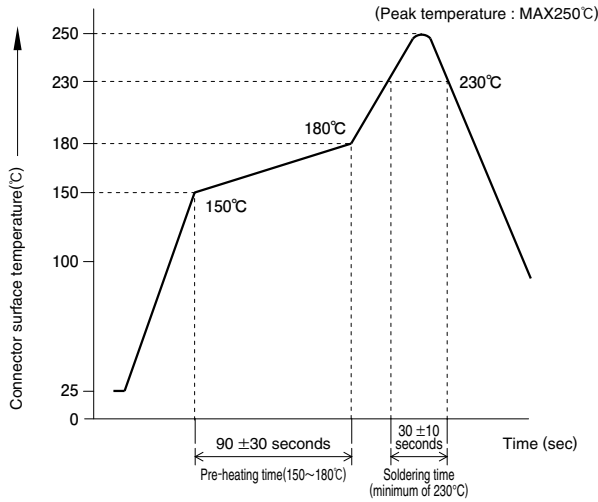

(Applicable Conditions)

Test PCB Dimensions : 40×30×1(mm)
 Reflow method Material : glass epoxy
 Solder Composition : Sn-3 Ag-0.5 Cn
 (flux component : 10.5wt%)
 Metal mask thickness : 0.12mm

- Note 1 : This temperature profile is a recommended value.
 Note 2 : The reflow process should not be conducted more than two times.
 Note 3 : The values may show a slight variance due to solder paste type and thickness.

◆ Cleaning Conditions

Cleaning with organic solvents

Solvent	Clean at normal temperature	Heated cleaning
IPA (Isopropyl alcohol)	○	○

Water cleaning

If wet cleaning is necessary, please select the proper cleaning agent (terpene, alkali saponification agent etc.) based on the reaction it will have on the metals and resins of the connector. This information is issued by the manufacturer of the cleaning agent. Additionally, please make sure not to apply an excessive amount of the cleaning agent.

Points to note during cleaning

When using organic solvents or wet cleaning agents, please ensure proper rinsing is done to eliminate the possibility of deterioration in electrical performance caused by flux or cleaning agents remaining in the connector.

Plug

Right-angle batch cable assembly type

Unit : mm

Part No.	HRS No.	No. of Contacts (n)	A	B	C	D	RoHS
FX16-21P-0.5SD	575-3301-7	21	21.9	19.6	17.57	10	○
FX16-31P-0.5SD	575-3302-0	31	26.9	24.6	22.57	15	

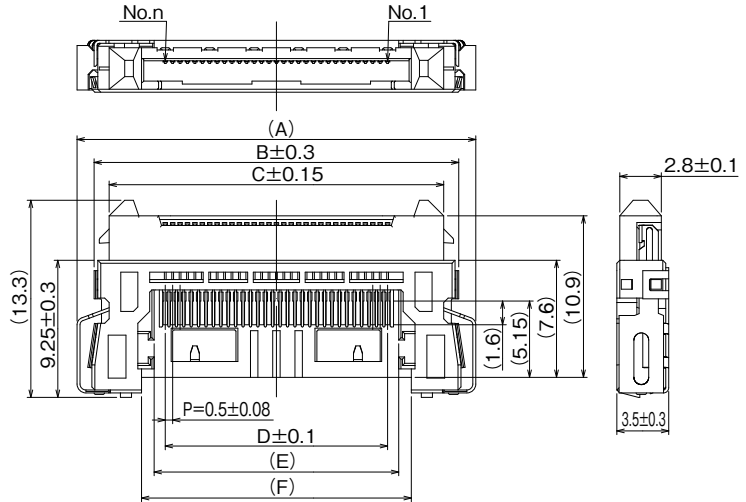

Notes :

- () shows a reference dimension.
- During the manufacturing process, products may incur some minor cosmetic damage (dents/scratches) or black spots in the resin, but these small imperfections will not affect their performance.
- This product is delivered in a tray package.

Right-angle-type cover shell for micro axial cables

Unit : mm

Part No.	HRS No.	No. of Contacts (n)	A	B	C	RoHS
FX16-21P-GND	575-3311-0	21	19.2	13.2	20.06	○
FX16-31P-GND	575-3312-3	31	24.2	18.2	25.06	

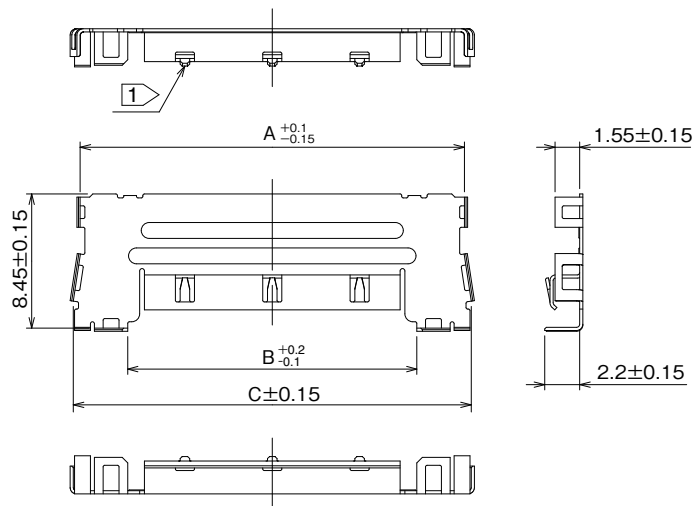
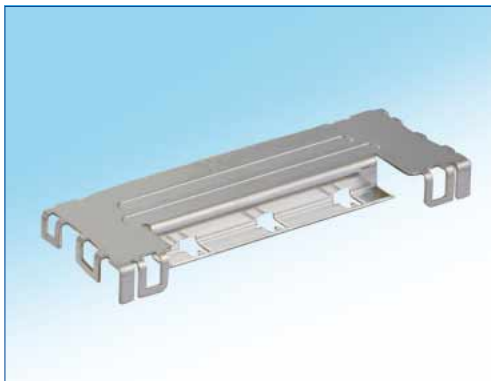

Notes :

- During the manufacturing process, products may incur some minor cosmetic damage (dents/scratches), but this will not affect their performance.
- This product is delivered packaged on a 2500pcs/reel.
- This product is an accessory to the separately sold item "Right angle batch cable connection type plug (FX16-**-P-0.5SD)". Please be sure to use them together.

●Vertical batch cable connection type

Unit : mm

Part No.	HRS No.	No. of Contacts (n)	A	B	C	D	E	F	RoHS
FX16-21P-0.5SDL	575-3321-4	21	18.07	13.7	11.5	10	23.6	17.57	○
FX16-31P-0.5SDL	575-3322-7	31	23.07	18.7	16.5	15	28.6	22.57	

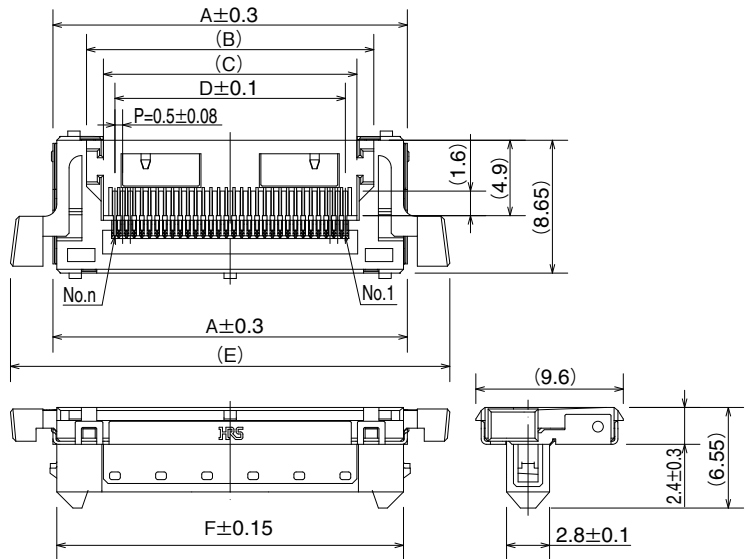

Notes :

1. () shows a reference dimension.
2. During the manufacturing process, products may incur some minor cosmetic damage (dents/scratches) or black spots in the resin, but these small imperfections will not affect their performance.
3. This product is delivered in a tray package.

●Vertical type cover shell for micro coaxial cables

Unit : mm

Part No.	HRS No.	No. of Contacts (n)	A	B	C	RoHS
FX16-21P-GNDL	575-3331-8	21	20.37	11.47	18.17	○
FX16-31P-GNDL	575-3332-0	31	25.37	16.47	23.17	

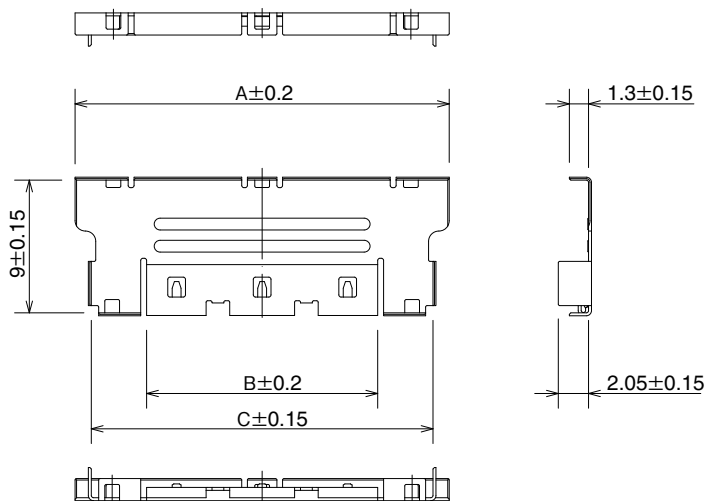
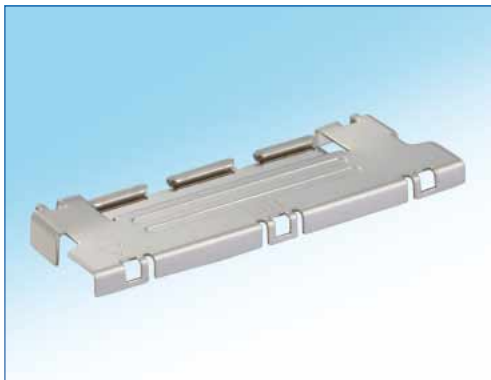

Notes :

1. During the manufacturing process, products may incur some minor cosmetic damage (dents/scratches), but this will not affect their performance.
2. This product is delivered packaged on a 2000pcs/reel.
3. This product is a compliment to the separately sold item "vertical batch cable assembly type plug (FX16-***P-0.5SDL)". Please be sure to use them together.

◆ Applicable wires

● Micro coaxial cables

Applicable conductor size (core structure)	Insulation diameter
36 AWG# (7pcs/0.05mm)	φ0.3~φ0.5mm
38 AWG# (7pcs/0.04mm)	
40 AWG# (7pcs/0.03mm)	

No. of Contacts (n)	Applicable connectors	A	B	C
21	FX16-21P-0.5SD	13.1	10	4.55
	FX16-21P-0.5SDL			4.3
31	FX16-31P-0.5SD	18.1	15	4.55
	FX16-31P-0.5SDL			4.3

Recommended micro coaxial cable dimensions

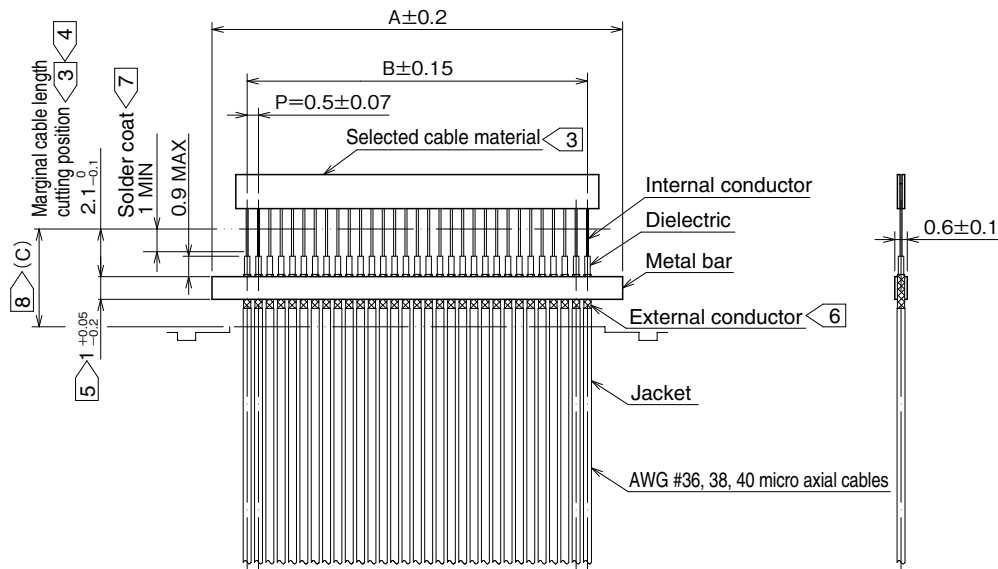

Notes :

- 1 () shows a reference dimension.
- 2 Pulse heat batch soldering is recommended to affix the harness to the connector
- 3 To prevent any conductor deformation prior to harnessing, please use the cable material immediately after cutting
- 4 After confirming that the soldered state has no problems, departure from recommended values is permissible
- 5 Use of out-of-spec dimension cables may hinder the correct attachment to the connector. Additionally, use of excessive force during cable connection may cause faults such as unsoldered areas and disconnects.
- 6 The protrusion of the external conductor from the metal bar should be minimized.
- 7 Apply a solder coat (pre-tinning) on the internal conductor.
- 8 Shows the position at which the connector should be connected and the cable inserted into the connector when the cable has been stripped at the recommended length.
If cable is stripped at a different length, the amount of cable insertion will need to be changed as well.

●FFC holder type (FX16F-**P-HC)

Unit : mm

Part No.	HRS No.	No. of Contacts (n)	A	B	C	RoHS
FX16F-21P-HC	575-3265-5	21	22.4	17.57	20.4	○
FX16F-31P-HC	575-3266-8	31	27.4	22.57	25.4	

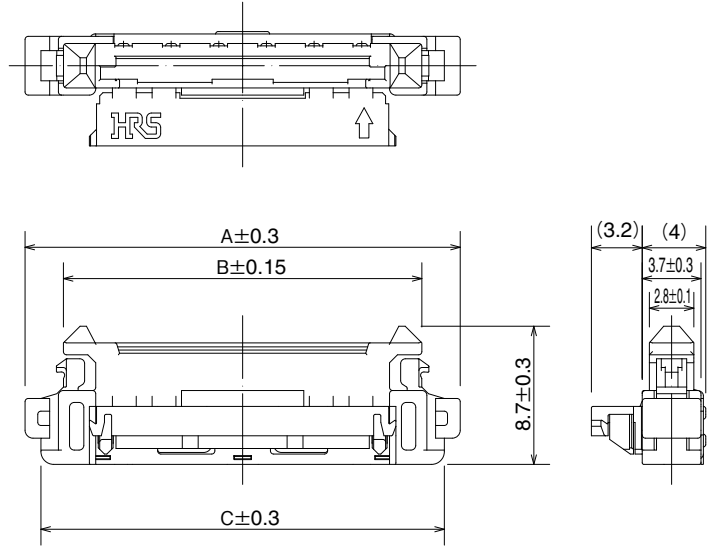

Notes :

- () shows a reference dimension.
- During the manufacturing process, products may incur some minor cosmetic damage (dents/scratches). But this will not affect their performance. Additionally there may be mold sinks present.
- This product is delivered in a tray package.

●FFC holder type (FX16M2-**P-HC)

Unit : mm

Part No.	HRS No.	No. of Contacts (n)	A	B	RoHS
FX16M2-41P-HC	575-3262-7	41	35.4	27.57	○
FX16M2-51P-HC	575-3263-0	51	40.4	32.57	

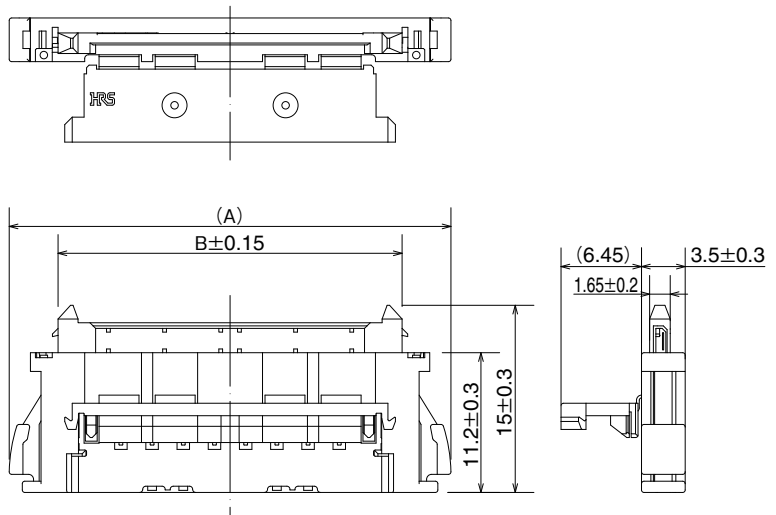

Notes :

- () shows a reference dimension.
- During the manufacturing process, products may incur some minor cosmetic damage (dents/scratches), but this will not affect their performance. Additionally there may be mold sinks present.
- This product is delivered in a tray package.

Jun. 1. 2024 Copyright 2024 HIROSE ELECTRIC CO., LTD. All Rights Reserved.

◆ Applicable wires

● Completely shielded FFC for holder type

Unit : mm

No. of Contacts (n)	Applicable connectors	A	B	C	D	E	F
21	FX16F-21P-HC	13.2	12.8	11.2	10	12.8	10.7
31	FX16F-31P-HC	18.2	17.8	16.2	15	17.8	15.7

Recommended FFC dimensions

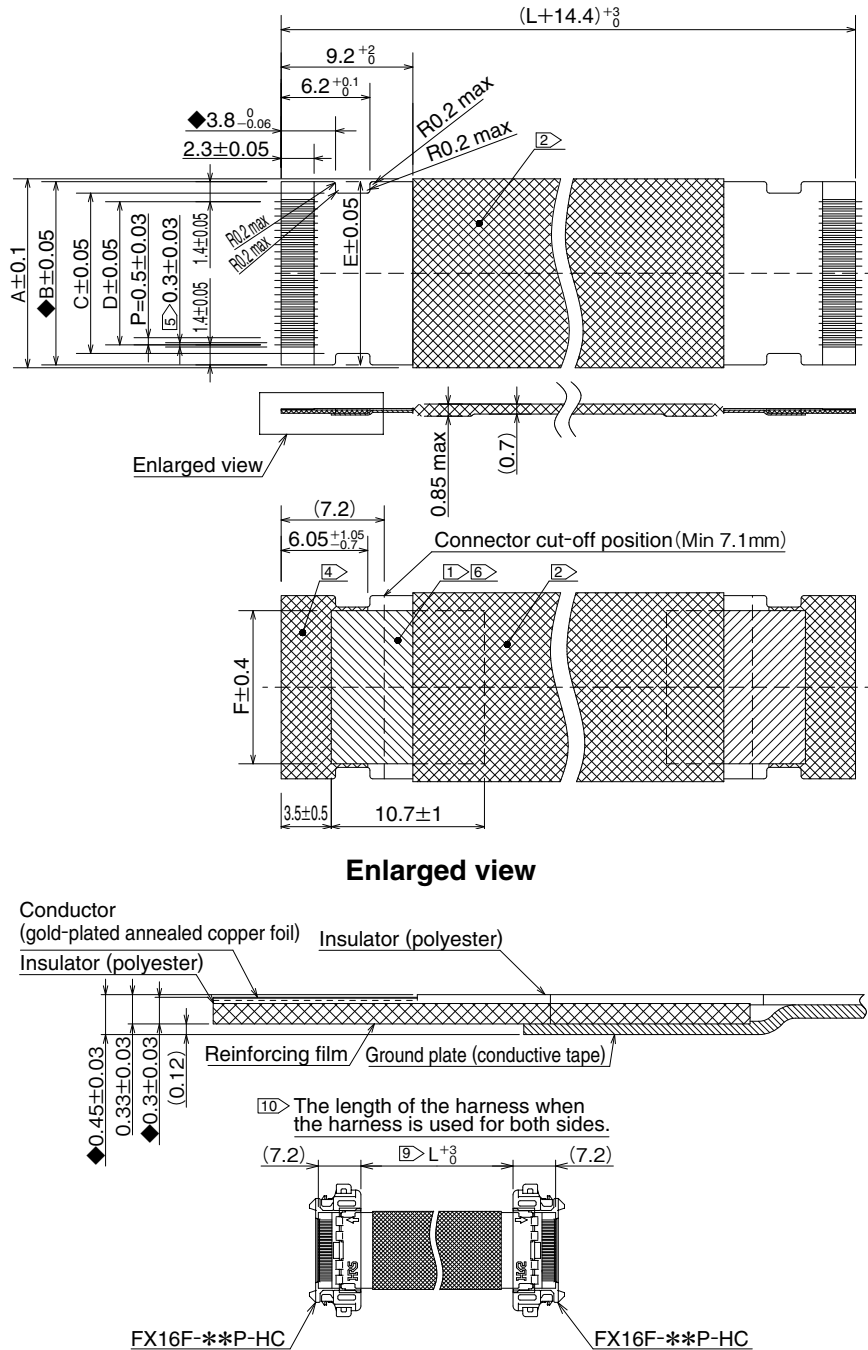

Notes :

- ① The plating on the ground plate (tape) must be at least $1.5\mu\text{m}$ of Sn plating, with the first 1 to $5\mu\text{m}$ of Ni plating + at least $0.2\mu\text{m}$ of Au plating on the pad surface as well as C-2000-equivalent sealing.
- ② denotes the shielded area. (both sides are shielded).
- ③ denotes the area for the ground plate (conductive tape).
- ④ denotes the area for the reinforcing film.
- ⑤ The width of the conductor must be $0.3 \pm 0.03\text{mm}$.
- ⑥ The ground plate (tape) and shield must overlap each other. This will allow a conductive path to be established through both ground plates and on both sides.
- ⑦ FFC must be made to satisfy the differential impedance value of $100\Omega \pm 7\%$.
- ⑧ () denotes the reference dimension and ◆ mark denotes important dimensions.
- ⑨ The L dimension is the length of the harness from one end face to the other end face of the connector cable port.

Precautions of use

◆Plug (Vertical/horizontal batch cable connection type)

[Precautions for soldering]

[1] Recommended soldering iron

Wire solder with flux (lead-free type: Sn-3Au-0.5Cu)

When using micro coax cables.....φ0.15 Length : number of pos. ×0.5mm

Be careful not use an excessive amount of flux, especially when using a wire solder that contains flux. Doing so may cause the flux to run up to the contact portion which can lead to contact failure.

[2] Prior to fixing the cables to the connector, make sure that the conductor is placed correctly in the center of the contact.

Fix the cable at the metal bar guide on the connector.

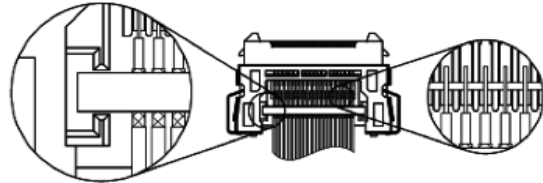

[3] Before you solder down the cables onto the connector, please check for the following issues :

- Deformation of the conductor
- Pitch deviations to the conductor relative to the contact
- Extreme uplift of the conductor tip end

This feature can lead to unsoldered spaces or solder bridges.

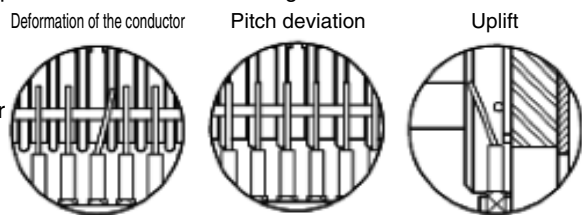

[4] Recommended pulse heat conditions

Conditions will vary depending on the length/type of cable used, type of solder, etc...

Please reference the recommended profile conditions when setting up your working conditions.

Pressure on the iron tip	13-17N
--------------------------	--------

Main heating	
Temperature (Y)	275±5°C
Hold time (X)	2 ±0.5 seconds

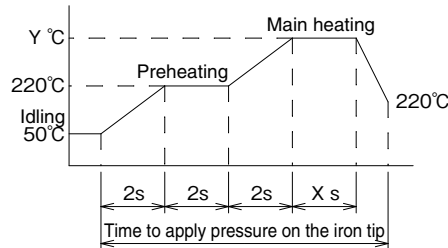

[5] Please check the soldered part after soldering to ensure no deformities were made. The illustrations below depict some examples of correct parts and some examples of incorrectly soldered parts.

Example of a correctly soldered part



The conductor is located at the center of the contact, and the whole area is uniformly soldered.

Examples of incorrectly soldered parts



Solder bridge

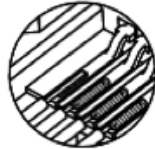

Insufficient amount of solder used

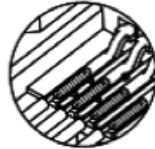

Scattered solder balls



Floating



Uplift of the conductor

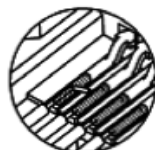

The conductor is located too close to the extended contact.

Precautions of use

[Precautions for resin sealing]

- [1] To prevent insulation failure due to foreign materials, cable disconnection during the routing of the cable and other failures, we recommend that the soldered area be protected with an ultraviolet curable resin or another equivalent material. Recommended resin sealing material : Ultraviolet curable resin 3033 manufactured by ThreeBond Co., Ltd.
- [2] Please refer to the resin manufacturer's directions for recommended usage conditions.
- [3] Ensure that the complete soldering area of the conductor is covered with resin. Be careful not to let the applied resin flow into or stick to the connector contacts.

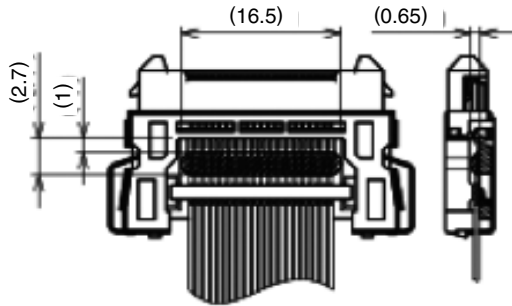

- [4] Please pay close attention to the load (e.g. tension, stress.) placed on the soldered part after soldering. Poor handling could cause cable disconnection.

[How to mount the cover shell]

- [1] After connecting the cables, mount the separately sold cover shell (for micro coax cables : FX16-31P-GND).
- [2] Place the cover shell over the connector from above, set it on the connector while holding it with your fingers.

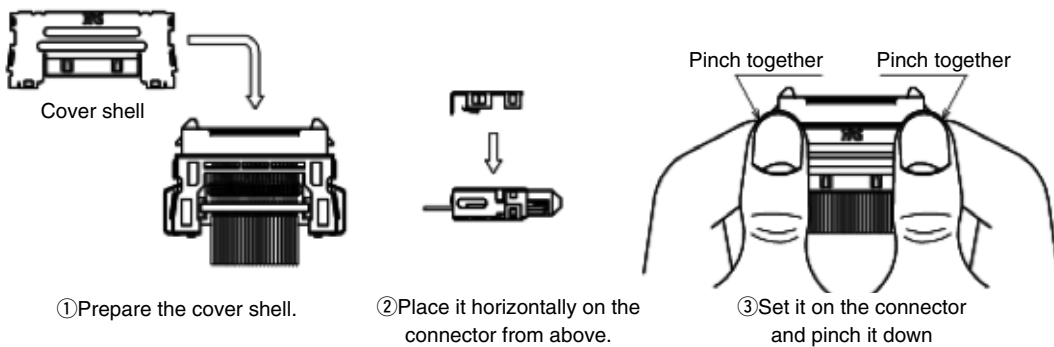

- [3] After applying it to the connector, check to see if all six "joining point" locations are correctly in place.



Illustration showing proper joining

(cross-section of the joining point).

The cover shell is locked into place and is seated correctly.

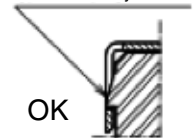

The cover shell is not locked and is still incomplete.

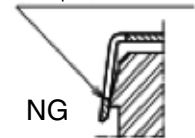

Precautions of use

[Ground soldering of the connector to the cable]

[1] Soldering the metal bar of the cable and the connector shell will enhance the shielding properties and provide additional cable strain relief.

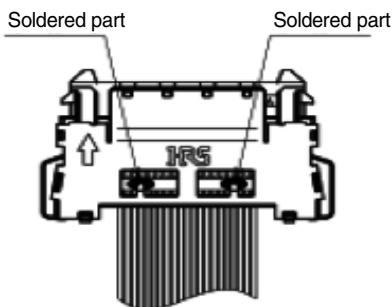

[2] Do not apply too much solder as this can lead to deformation/melting of the cable/connector due to the heat generated while soldering.

◆Plug (FFC holder type)

[Precautions during harness work]

[1] Inserting FFC

Insert the FFC straight along the guide rib of the mold, as shown in the following figure. It cannot be inserted in different directions. Please be careful not to deform FFC or damage the case or spring contact.

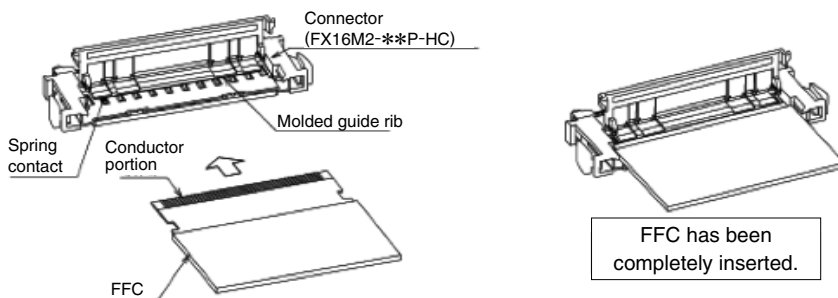

[2] Confirming the insertion of the FFC

Check if the FFC has been inserted correctly by observing the tip end of the FFC from above the connector.
 * If the FFC was inserted correctly, the tip of the FFC will meet up with the wall of the connector.

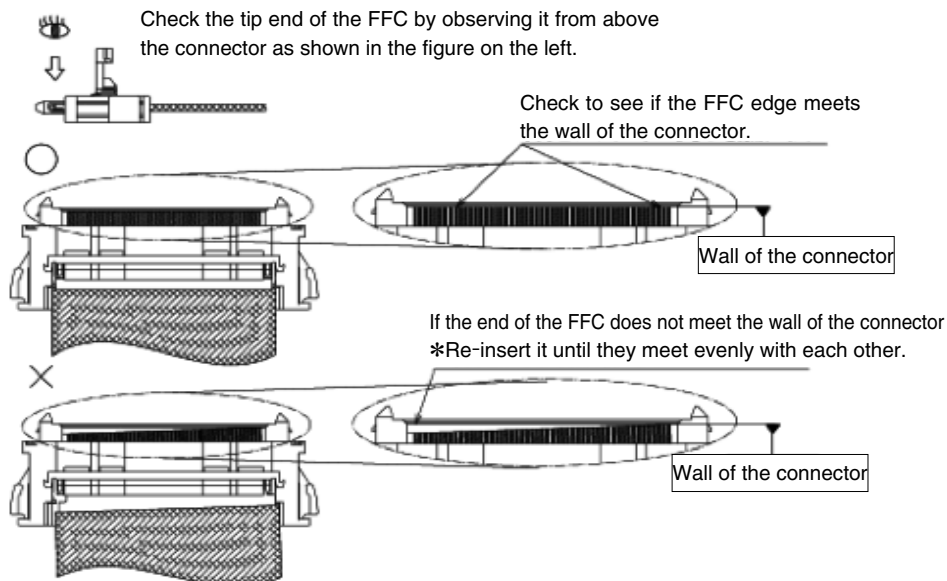

Precautions of use

[3] Fixing the FFC

As shown in the figure below, hold the connector in both hands and push the lock straight with both thumbs. At this time, verify the hooks are tightly attached to each other on both sides. Additionally, after closing the lock, verify that the FFC cannot be easily pulled out, and that the hooks on both sides are tightly attached to each other by holding both ends of the assembly and pulling the FFC in the drawing direction with a force of 3 to 5 N

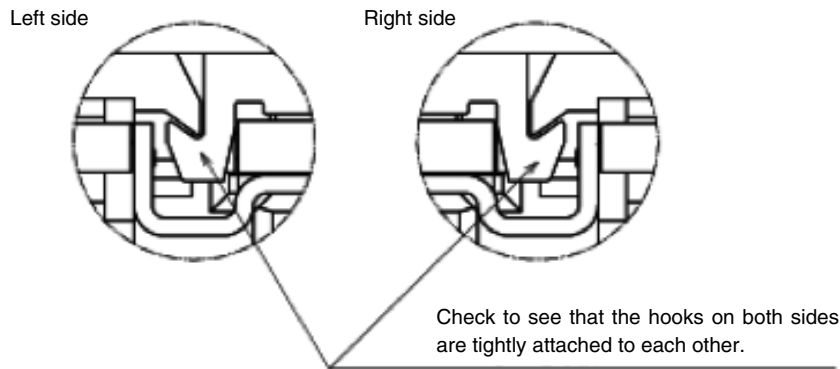
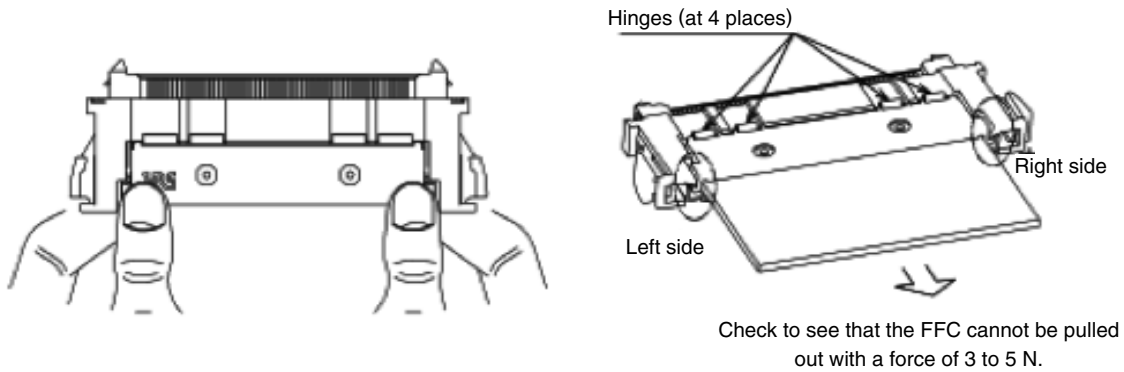

[4] Other cautions

- ① From the time of opening the package until the assembly process, please do not handle the product in the manner which will cause the lock of the connector to be pushed down. If the lock gets deflected in the direction shown in the figure below, discard the connector.

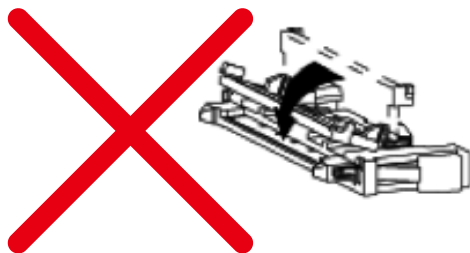

- ② Once FFC has been removed from the connector, do not reuse the connector.
- ③ At the time of packing the harness, be careful not to let the connector be damaged or deformed.

Precautions of use

◆General cautions

[Cautions for handling]

[1] Insertion into the connector on the side of PCB

The mating direction of this connector has been specified. Mating should be done with the mark facing the direction shown in the figure below. Additionally, insertion should be done until the locks on both sides are set.

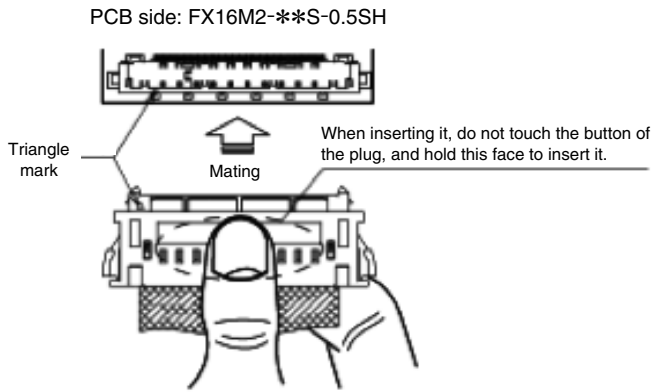

Although this connector is designed to prevent reverse insertion, the connector could be damaged if it were mated forcibly with a force exceeding 25 N. Avoid forced mating, and please verify the triangle mark position before mating.

Do not pull it out at an angle as shown in the figure below. This could damage the connector.

[2] Unmating the connector mounted on a PCB

This connector is structured to lock on both ends when mated. When unmating the connector, pull it out straight while pushing on both sides with your fingers to unlock it. Please do not pull out FFC with a strong force.

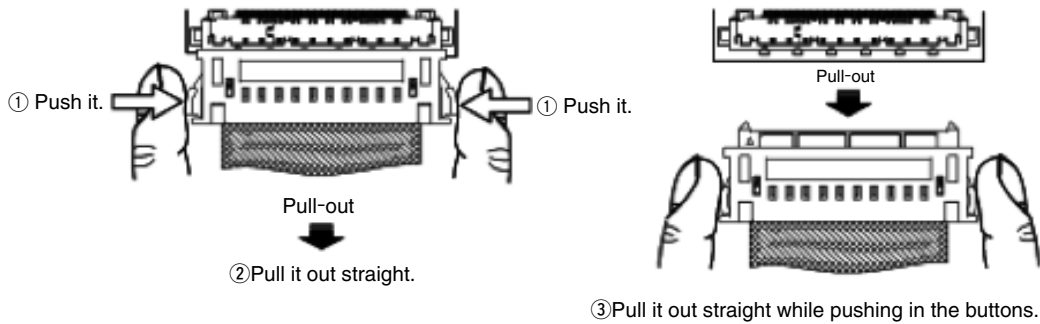

Do not pull it out at an angle as shown in the figure below. This could damage the connector.

<Incorrect insertion method>



Precautions of use

<Incorrect pull-out method>

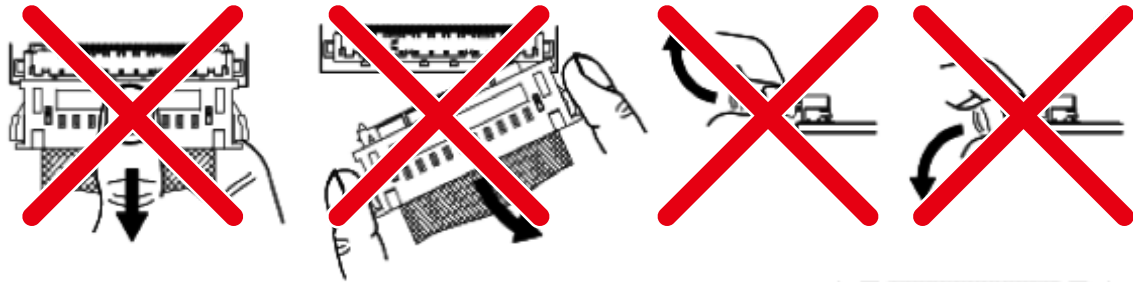

[3] In the case when the connector has been unmated forcibly.
 If the connector has been unmated forcibly, push it back once to the completely mated condition, from this state, pull the plug by the "correct pull-out method".



Be sure to push it once to the completely mated condition.

[4] In the case when you have pulled it out with one side locked
 If the plug has been pulled out with one side locked, the locked part could be damaged if you pull it out forcibly.
 In such a situation, do not try to unlock it forcibly, but mate the plug again as it is, and pull out the plug by the "correct pull-out method" again with both sides locked.

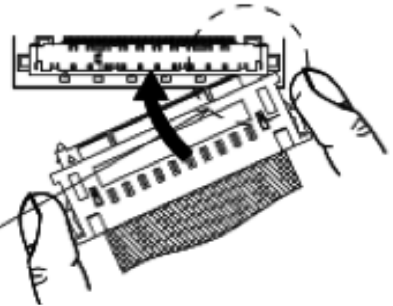

If the plug has been pulled out with one side locked, be sure to mate them again.

[5] Handling after mating
 After mating, be careful not to apply load to the connector during cable routing.
 The connector could be damaged if you pull the cable with a force of 20 N or more. Additionally, it could cause cable disconnection.
 Please make sure that you do not pull the cable forcibly.

Repeated strain could also cause cable disconnection.
 Avoid any use which involves repeated strain.

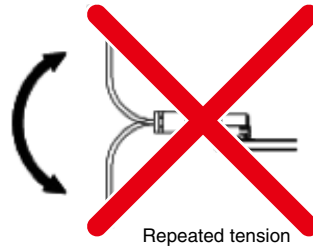

When you use a cable that is folded back from the connector base, please maintain a large bend radius or keep the folding position away from the connector base in order minimize the load on the connector.

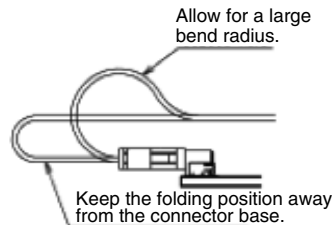

Using the cable in a folded state.

USA:

HIROSE ELECTRIC (U.S.A.), INC. HEADQUARTERS CHICAGO OFFICE
 2300 Warrenville Road, Suite 150,
 Downers Grove, IL 60515
 Phone : +1-630-282-6700
<http://www.hirose.com/us/>

USA:

HIROSE ELECTRIC (U.S.A.), INC. SAN JOSE OFFICE
 2841 Junction Ave, Suite 200
 San Jose, CA. 95134
 Phone : +1-408-253-9640
 Fax : +1-408-253-9641
<http://www.hirose.com/us/>

USA:

HIROSE ELECTRIC (U.S.A.), INC. DETROIT OFFICE (AUTOMOTIVE)
 17197 N. Laurel Park Drive, Suite 253,
 Livonia, MI 48152
 Phone : +1-734-542-9963
 Fax : +1-734-542-9964
<http://www.hirose.com/us/>

USA:

HIROSE ELECTRIC (U.S.A.), INC. BOSTON OFFICE
 300 Brickstone Square Suite 201,
 Andover, MA 01810
 Phone : +1-978-662-5255

THE NETHERLANDS:

HIROSE ELECTRIC EUROPE B.V.
 Hogehillweg #8 1101 CC Amsterdam Z-0
 Phone : +31-20-6557460
 Fax : +31-20-6557469
<http://www.hirose.com/eu/>

GERMANY:

HIROSE ELECTRIC EUROPE B.V. GERMAN BRANCH
 Schoenbergstr. 20, 73760 ostfildern
 Phone : +49-711-456002-1
 Fax : +49-711-456002-299
<http://www.hirose.com/eu/>

GERMANY:

HIROSE ELECTRIC EUROPE B.V. NUREMBERG OFFICE
 Neumeyerstrasse 22-26, 90411 Nurnberg
 Phone : +49-911 32 68 89 63
 Fax : +49-911 32 68 89 69
<http://www.hirose.com/eu/>

GERMANY:

HIROSE ELECTRIC EUROPE B.V. HANOVER OFFICE
 Bayernstr. 3, Haus C 30855 Langenhagen, Germany
 Phone : +49-511 97 82 61 30
 Fax : +49-511 97 82 61 35
<http://www.hirose.com/eu/>

FRANCE:

HIROSE ELECTRIC EUROPE B.V. PARIS OFFICE
 130 Avenue Joseph Kessel, Bat E, 78960
 Voisins le Bretonneux, France
 Phone : +33-1-85764886
 Fax : +33-1-85764823
<http://www.hirose.com/eu/>

UNITED KINGDOM:

HIROSE ELECTRIC EUROPE BV (UK BRANCH)
 4 Newton Court, Kelvin Drive, Knowlhill,
 Milton Keynes, MK5 8NH
 Phone : +44-1908 202050
 Fax : +44-1908 202058
<http://www.hirose.com/eu/>

CHINA:

HIROSE ELECTRIC (SHANGHAI) CO., LTD.
 18, Enterprise Center Tower 2, 209# Gong He
 Road, Jing'an District, Shanghai, CHINA 200070
 Phone : +86-21-6391-3355
 Fax : +86-21-6391-3335
<http://www.hirose.com/cn/>

CHINA:

HIROSE ELECTRIC (SHANGHAI) CO.,LTD. BEIJING BRANCH
 A1001, Ocean International Center, Building 56# East 4th
 Ring Middle Road, ChaoYang District, Beijing, 100025
 Phone : +86-10-5165-9332
 Fax : +86-10-5908-1381
<http://www.hirose.com/cn/>

CHINA:

HIROSE ELECTRIC TECHNOLOGIES (SHENZHEN) CO., LTD.
 Room 09-13, 19/F, Office Tower Shun Hing Square, Di Wang Commercial Centre,
 5002 Shen Nan Dong Road, Shenzhen City, Guangdong Province, 518008
 Phone : +86-755-8207-0851
 Fax : +86-755-8207-0873
<http://www.hirose.com/cn/>

HONG KONG:

HIROSE ELECTRIC HONGKONG TRADING CO., LTD.
 Room 1001, West Wing, Tsim Sha Tsui Centre, 66
 Mody Road, Tsim Sha Tsui East, Kowloon, Hong Kong
 Phone : +852-2803-5338
 Fax : +852-2591-6560
<http://www.hirose.com/hk/>

TAIWAN:

HIROSE ELECTRIC TAIWAN CO., LTD.
 103 8F, No.87, Zhengzhou Rd., Taipei
 Phone : +886-2-2555-7377
 Fax : +886-2-2555-7355
<http://www.hirose.com/tw/>

KOREA:

HIROSE KOREA CO.,LTD.
 143, Gongdan 1-daero, Siheung-si,
 Gyeonggi-do, 15084, Korea
 Phone : +82-31-496-7000
 Fax : +82-31-496-7100
<http://www.hirose.co.kr/>

SINGAPORE:

HIROSE ELECTRIC SINGAPORE PTE. LTD.
 03, Anson Road, #20-01, Springleaf Tower,
 Singapore 079909
 Phone : +65-6324-6113
 Fax : +65-6324-6123
<http://www.hirose.com/sg/>

INDIA:

HIROSE ELECTRIC SINGAPORE PTE. LTD. DELHI LIAISON OFFICE
 Office NO.552, Regus-Green Boulevard, Level5, Tower C,
 Sec62, Plot B-9A, Block B, Noida, 201301, Uttar Pradesh, India
 Phone : +91-12-660-8018
 Fax : +91-120-4804949
<http://www.hirose.com/sg/>

INDIA:

HIROSE ELECTRIC SINGAPORE PTE. LTD. BANGALORE LIAISON OFFICE
 Unit No-403, 4th Floor, No-84, Barton Centre, Mahatma
 Gandhi (MG) Road, Bangalore 560 001, Karnataka, India
 Phone : +91-80-4120 1907
 Fax : +91-80-4120 9908
<http://www.hirose.com/sg/>

MALAYSIA:

PENANG REPRESENTATIVE OFFICE
 73-3-1, Ideal@The One, Jalan Mahsuri, Bayan
 Lepas Penang, 11950, Malaysia
 Phone : +604-648-5536
<http://www.hirose.com/sg/>

THAILAND:

BANGKOK OFFICE (REPRESENTATIVE OFFICE)
 Unit 4703, 47th FL., 1 Empire Tower, South Sathorn
 Road, Yannawa, Sathorn, Bangkok 10120 Thailand
 Phone : +66-2-686-1255
 Fax : +66-2-686-3433
<http://www.hirose.com/sg/>





HIROSE ELECTRIC CO.,LTD.

2-6-3,Nakagawa Chuoh,Tsuzuki-Ku,Yokohama-Shi 224-8540,JAPAN
 TEL: +81-45-620-3526 Fax: +81-45-591-3726
<http://www.hirose.com>
<http://www.hirose-connectors.com>

Looking for pricing, stock, or lifecycle information?

Click below to explore more details on WIN SOURCE:

-  [View FX16F-21P-HC on WIN SOURCE](#)
-  [Hirose Electric Co Ltd Information](#)

Optimize Your Supply Chain with WIN SOURCE Solutions

-  Global Sourcing Solution
-  Obsolete Management
-  Cost Control Management
-  Shortage Management
-  Alternative Solution
-  Excess Inventory Management