



**THE DATASHEET OF
LTC3879IMSE#PBF**



Fast, Wide Operating Range No R_{SENSE} Step-Down Controller

FEATURES

- Wide V_{IN} Range: 4V to 38V
- ±1% 0.6V Voltage Reference
- Extremely Fast Transient Response
- t_{ON(MIN)}: 43ns
- No R_{SENSE}[™] Valley Current Mode Control
- Stable with Low ESR Ceramic C_{OUT}
- Supports Smooth Start-Up in Pre-Biased Output
- Optimized for High Step-Down Ratios
- Adjustable Output Voltage Soft-Start or Tracking
- Power Good Output Voltage Monitor
- Dual N-Channel MOSFET Synchronous Drive
- Adjustable Switching Frequency
- Programmable Current Limit with Foldback
- Output Overvoltage Protection
- 16-Pin MSOP and 3mm × 3mm QFN Packages

APPLICATIONS

- Distributed Power Systems
- Embedded Computing
- Communications Infrastructure

LT, LT, LTC and LTM are registered trademarks of Linear Technology Corporation.
 No R_{SENSE} is a trademark of Linear Technology Corporation.
 All other trademarks are the property of their respective owners.
 Protected by U.S. Patents, including 5481178, 6100678, 6580258, 5847554, 6304066.

DESCRIPTION

The LTC[®]3879 is a synchronous step-down switching regulator controller optimized for high switching frequency and fast transient response. The constant on-time valley current mode architecture allows for a wide input range, including very low duty factor operation. No external sense resistor or slope compensation is required. System flexibility is offered through a user-programmable soft-start pin and independent RUN pin. The voltage ramping soft-start function can be programmed with a capacitor or made to track an external reference source.

Operating frequency is set by an external resistor and compensated for variations in V_{IN} to offer excellent line stability. Discontinuous mode operation provides high efficiency during light load conditions. A forced continuous control pin allows the user to reduce noise and RF interference. Safety features include output overvoltage protection and programmable current limit with foldback. The current limit is user programmable.

The LTC3879 allows operation from 4V to 38V at the input and from 0.6V to 90% V_{IN} at the output. The LTC3879 is available in a small 16-pin thermally enhanced MSOP or 3mm × 3mm QFN packages.

TYPICAL APPLICATION

High Efficiency Step-Down Converter

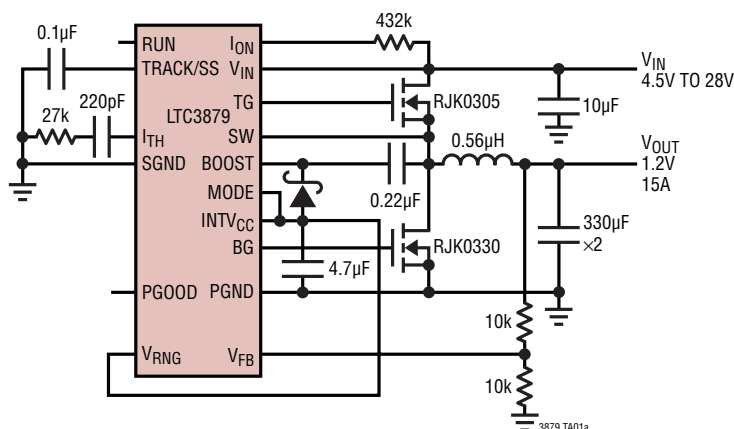

Efficiency vs Load Current

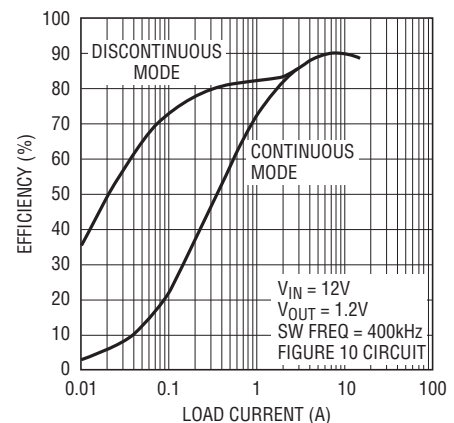

ABSOLUTE MAXIMUM RATINGS (Note 1)

Input Supply Voltage (V_{IN})	-0.3V to 40V	V_{FB} , I_{TH} Voltages	-0.3V to 2.7V
I_{ON} Voltage	-0.3V to 40V	Operating Temperature Range (Note 4)....	-40°C to 85°C
BOOST Voltage	-0.3V to 46V	Junction Temperature (Note 2)	125°C
SW Voltage	-5V to 40V	Storage Temperature Range.....	-65°C to 150°C
INTV _{CC} , (BOOST-SW), TRACK/SS, RUN, PGOOD Voltages	-0.3V to 6V	Lead Temperature (Soldering, 10 sec) MSOP Only	300°C
MODE, V_{RNG} Voltages	-0.3V to INTV _{CC} + 0.3V		

PIN CONFIGURATION

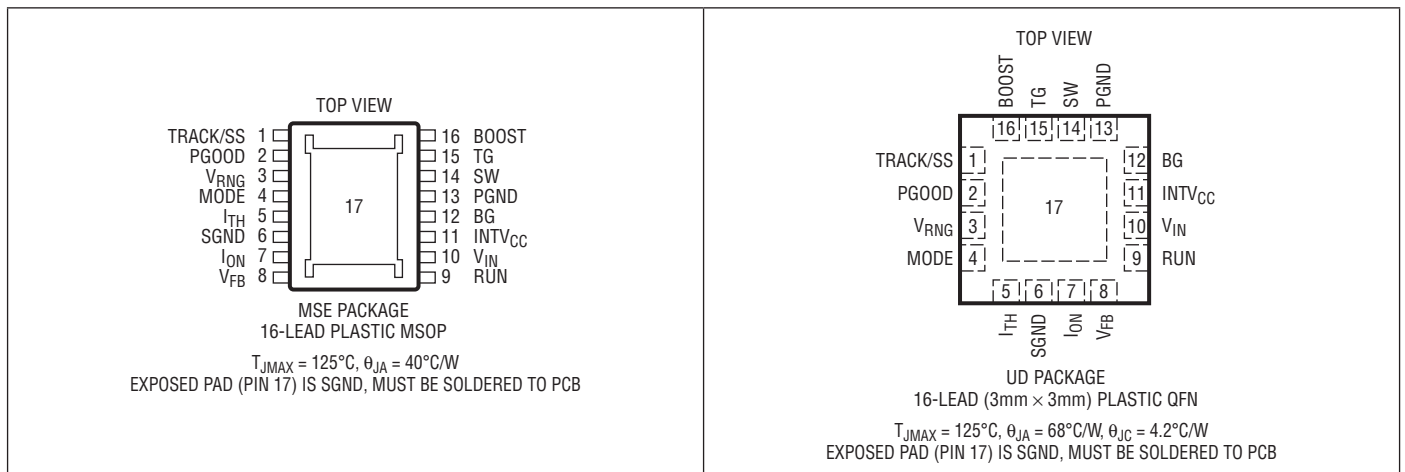

ORDER INFORMATION

LEAD FREE FINISH	TAPE AND REEL	PART MARKING*	PACKAGE DESCRIPTION	TEMPERATURE RANGE
LTC3879EMSE#PBF	LTC3879EMSE#TRPBF	3879	16-Lead Plastic MSOP	-40°C to 85°C (Note 4)
LTC3879IMSE#PBF	LTC3879IMSE#TRPBF	3879	16-Lead Plastic MSOP	-40°C to 85°C (Note 4)
LTC3879EUD#PBF	LTC3879EUD#TRPBF	LDTM	16-Lead (3mm x 3mm) Plastic QFN	-40°C to 85°C (Note 4)
LTC3879IUD#PBF	LTC3879IUD#TRPBF	LDTM	16-Lead (3mm x 3mm) Plastic QFN	-40°C to 85°C (Note 4)

Consult LTC Marketing for parts specified with wider operating temperature ranges. *The temperature grade is identified by a label on the shipping container. Consult LTC Marketing for information on non-standard lead based finish parts.

For more information on lead free part marking, go to: <http://www.linear.com/leadfree/>

For more information on tape and reel specifications, go to: <http://www.linear.com/tapeandreel/>

ELECTRICAL CHARACTERISTICS

The ● denotes the specifications which apply over the full operating temperature range, otherwise specifications are at $T_A = 25^\circ\text{C}$. $V_{IN} = 15\text{V}$, unless otherwise noted.

SYMBOL	PARAMETER	CONDITIONS	MIN	TYP	MAX	UNITS
Main Control Loop						
	Input Operating Voltage Range		4		38	V
I_Q	Input DC Supply Current Normal			1350	2000	μA
	Shutdown Supply Current			18	35	μA
V_{FBREF}	Feedback Reference Voltage	$I_{TH} = 1.2\text{V}$ (Note 3)	● 0.594	0.6	0.606	V
	Feedback Voltage Line Regulation	$V_{IN} = 4\text{V to } 30\text{V}$, $I_{TH} = 1.2\text{V}$ (Note 3)		0.005		%/V
	Feedback Voltage Load Regulation	$I_{TH} = 0.5\text{V to } 1.9\text{V}$ (Note 3)	●	-0.05	-0.3	%
I_{FB}	Feedback Input Current	$V_{FB} = 0.6\text{V}$		-5	± 50	nA
$g_{m(EA)}$	Error Amplifier Transconductance	$I_{TH} = 1.2\text{V}$ (Note 3)	1.4	1.7	2	mS
V_{MODE}	MODE Threshold		0.76	0.8	0.84	V
	MODE Pin Current	$V_{MODE} = 0.8\text{V}$		0	± 1	μA
t_{ON}	On-Time	$I_{ON} = 30\mu\text{A}$	198	233	268	ns
		$I_{ON} = 15\mu\text{A}$	370	440	510	ns
$t_{ON(MIN)}$	Minimum On-Time	$I_{ON} = 180\mu\text{A}$		43	75	ns
$t_{OFF(MIN)}$	Minimum Off-Time	$I_{ON} = 30\mu\text{A}$		220	300	ns
$V_{SENSE(MAX)}$	Valley Current Sense Threshold $V_{PGND} - V_{SW}$ Peak Current = Valley + Ripple	$V_{RNG} = 1\text{V}$, $V_{FB} = 0.56\text{V}$	● 108	133	165	mV
		$V_{RNG} = 0\text{V}$, $V_{FB} = 0.56\text{V}$	● 22	30	48	mV
		$V_{RNG} = INTV_{CC}$, $V_{FB} = 0.56\text{V}$	● 62	75	98	mV
$V_{SENSE(MIN)}$	Minimum Current Sense Threshold $V_{PGND} - V_{SW}$ Force Continuous Operation	$V_{RNG} = 1\text{V}$, $V_{FB} = 0.64\text{V}$		-61		mV
		$V_{RNG} = 0\text{V}$, $V_{FB} = 0.64\text{V}$		-12		mV
		$V_{RNG} = INTV_{CC}$, $V_{FB} = 0.64\text{V}$		-33		mV
V_{RUN}	RUN On Threshold	V_{RUN} Rising	1.3	1.5	1.7	V
I_{RUN}	RUN Pull-Up Current	$V_{RUN} = 0\text{V}$		-1.2		μA
$I_{TRACK/SS}$	Soft-Start Charging Current	$V_{TRACK/SS} = 0\text{V}$	-0.45	-1	-2	μA
	INTV _{CC} Undervoltage Lockout	Falling	●	3.3	3.9	V
	INTV _{CC} Undervoltage Lockout Release	Rising	●	3.6	4	V
	TG Driver Pull-Up On-Resistance	TG High		2.5		Ω
	TG Driver Pull-Down On-Resistance	TG Low		1.2		Ω
	BG Driver Pull-Up On-Resistance	BG High		2.5		Ω
	BG Driver Pull-Down On-Resistance	BG Low		0.7		Ω
	TG Rise Time	$C_{LOAD} = 3300\text{pF}$ (Note 5)		20		ns
	TG Fall Time	$C_{LOAD} = 3300\text{pF}$ (Note 5)		20		ns
	BG Rise Time	$C_{LOAD} = 3300\text{pF}$ (Note 5)		20		ns
	BG Fall Time	$C_{LOAD} = 3300\text{pF}$ (Note 5)		20		ns
	Top Gate Off to Bottom Gate On Delay Synchronous Switch-On Delay Time	$C_{LOAD} = 3300\text{pF}$ Each Driver (Note 5)		15		ns
	Bottom Gate Off to Top Gate On Delay Top Switch-On Delay Time	$C_{LOAD} = 3300\text{pF}$ Each Driver (Note 5)		15		ns

ELECTRICAL CHARACTERISTICS

The ● denotes the specifications which apply over the full operating temperature range, otherwise specifications are at $T_A = 25^\circ\text{C}$. $V_{IN} = 15\text{V}$, unless otherwise noted.

SYMBOL	PARAMETER	CONDITIONS	MIN	TYP	MAX	UNITS
Internal V_{CC} Regulator						
	Internal V_{CC} Voltage	$6\text{V} < V_{IN} < 38\text{V}$	5.15	5.3	5.45	V
	Internal V_{CC} Load Regulation	$I_{CC} = 0\text{mA}$ to 20mA		-0.1	± 2	%
PGOOD Output						
	PGOOD Upper Threshold	V_{FB} Rising	7.8	10	12.2	%
	PGOOD Lower Threshold	V_{FB} Falling	-7.8	-10	-12.2	%
	PGOOD Hysteresis	V_{FB} Returning		2	3.8	%
	PGOOD Low Voltage	$I_{PGOOD} = 5\text{mA}$		0.15	0.4	V
	PGOOD Turn-On Delay			12		μs

Note 1: Stresses beyond those listed under Absolute Maximum Ratings may cause permanent damage to the device. Exposure to any Absolute Maximum Rating condition for extended periods may affect device reliability and lifetime.

Note 2: T_J is calculated from the ambient temperature T_A and power dissipation P_D , as follows:

$$T_J = T_A + (P_D \cdot \theta_{JA})$$

Note 3: The LTC3879 is tested in a feedback loop that adjusts V_{FB} to achieve a specified error amplifier output voltage (I_{TH}).

Note 4: The LTC3879E is guaranteed to meet specifications from 0°C to 85°C . Specifications over the -40°C to 85°C operating temperature range are assured by design, characterization and correlation with statistical process controls. The LTC3879I is guaranteed to meet specifications over the full -40°C to 85°C operating temperature range.

Note 5: Rise and fall time are measured using 10% and 90% levels. Delay times are measured using 50% levels.

TYPICAL PERFORMANCE CHARACTERISTICS

**Transient Response FCM
(Forced Continuous Mode)**

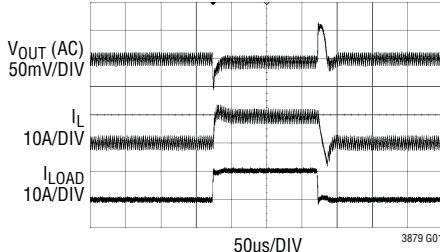

LOAD STEP 0A TO 10A TO 0A
 $V_{IN} = 12V$
 $V_{OUT} = 1.2V$
 $MODE = 0V$
 $SW\ FREQ = 400kHz$
 FIGURE 10 CIRCUIT

**Transient Response FCM
Positive Load Step**

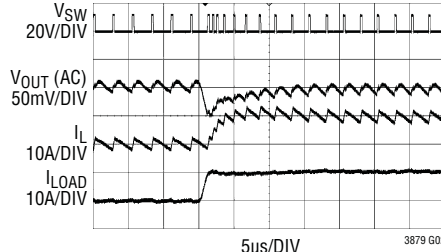

LOAD STEP 0A TO 10A
 $V_{IN} = 12V$
 $V_{OUT} = 1.2V$
 $MODE = 0V$
 $SW\ FREQ = 400kHz$
 FIGURE 10 CIRCUIT

**Transient Response FCM
Negative Load Step**

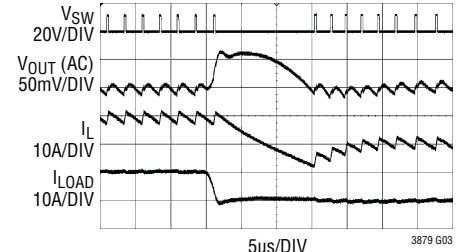

LOAD STEP 10A TO 0A
 $V_{IN} = 12V$
 $V_{OUT} = 1.2V$
 $MODE = 0V$
 $SW\ FREQ = 400kHz$
 FIGURE 10 CIRCUIT

**Transient Response DCM
(Discontinuous Mode)**

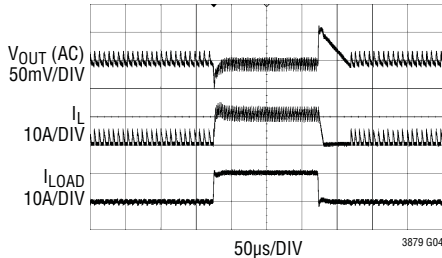

LOAD STEP 1A TO 11A TO 1A
 $V_{IN} = 12V$
 $V_{OUT} = 1.2V$
 $MODE = INTV_{CC}$
 $SW\ FREQ = 400kHz$
 FIGURE 10 CIRCUIT

**Normal Start-Up, RUN Pin
Released from GND**

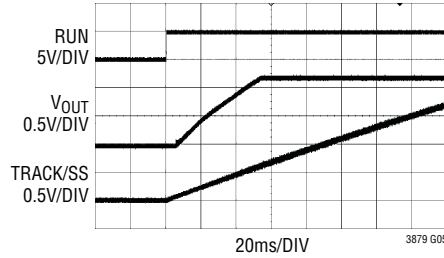

$V_{IN} = 12V$
 $V_{OUT} = 1.2V$
 $SW\ FREQ = 400kHz$
 FIGURE 10 CIRCUIT

**Start-Up Into a Pre-Biased Output
RUN Pin Released from GND**

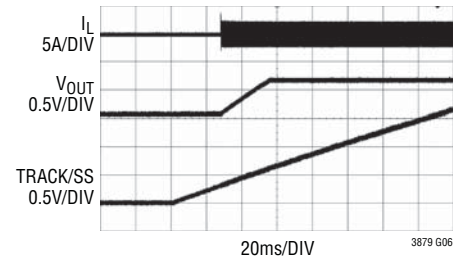

$V_{IN} = 12V$
 $V_{OUT} = 1.2V$
 $SW\ FREQ = 400kHz$
 FIGURE 10 CIRCUIT

**Start-Up After Input Undervoltage
 V_{IN} Cycled Low to High**

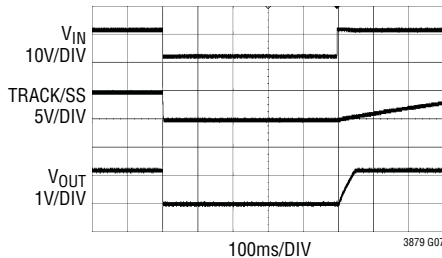

$V_{IN} = 12V$
 $V_{OUT} = 1.2V$
 $SW\ FREQ = 400kHz$
 FIGURE 10 CIRCUIT

**Coincident Rail Tracking 1.2V
 V_{OUT} Tracks External 1.8V Supply**

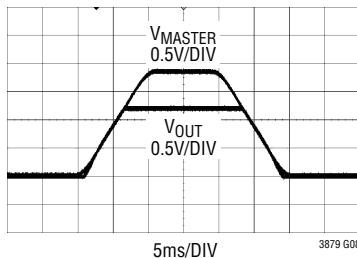

$V_{IN} = 12V$
 $V_{OUT} = 1.2V$
 $SW\ FREQ = 400kHz$
 FIGURE 10 CIRCUIT

Efficiency vs Load Current

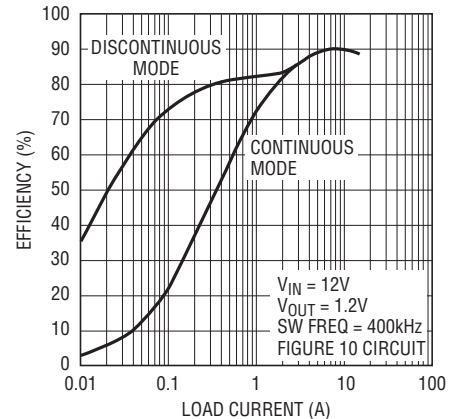

3879 G09

TYPICAL PERFORMANCE CHARACTERISTICS

Efficiency vs Input Voltage

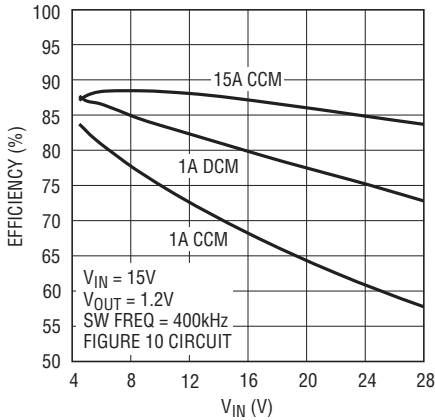

3879 G26

Frequency vs Input Voltage

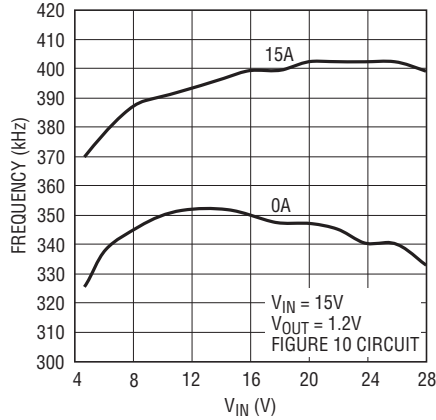

3879 G10

Frequency vs Load Current

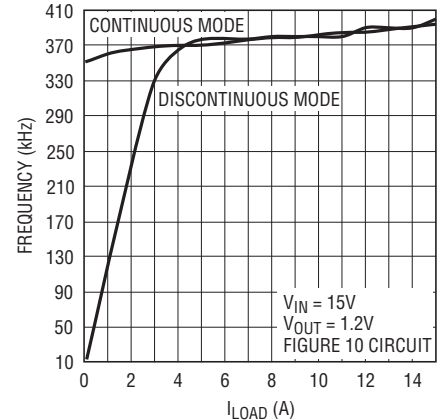

3879 G11

Current Sense Voltage vs I_{TH} Voltage

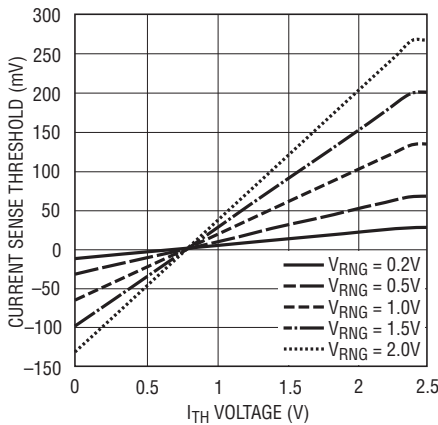

3879 G12

On-Time vs I_{ON} Current

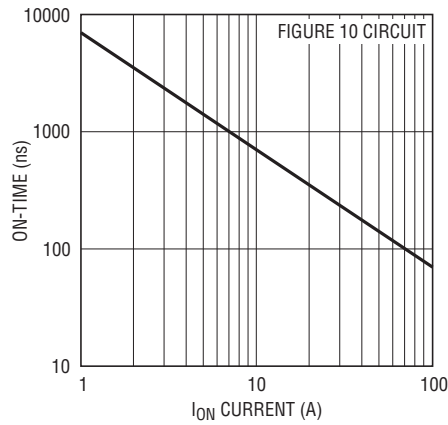

3879 G13

Current Limit Foldback

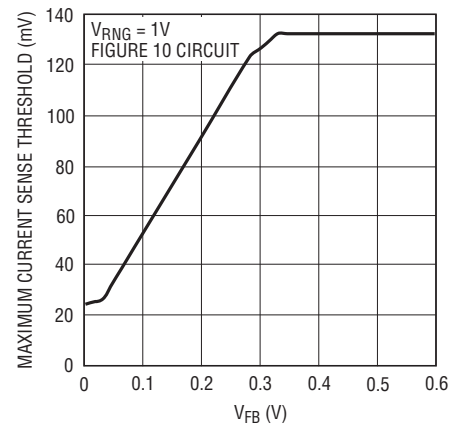

3879 G14

Maximum V_{DS} Current Sense Threshold vs V_{RNG} Voltage

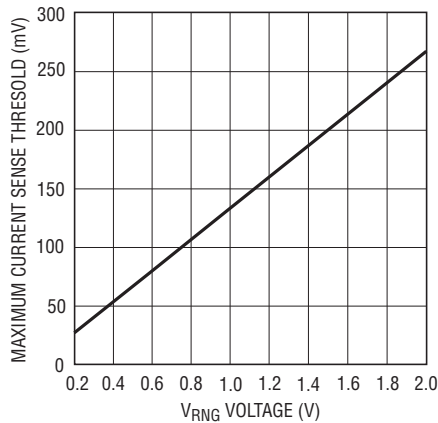

3879 G15

Load Regulation FCM

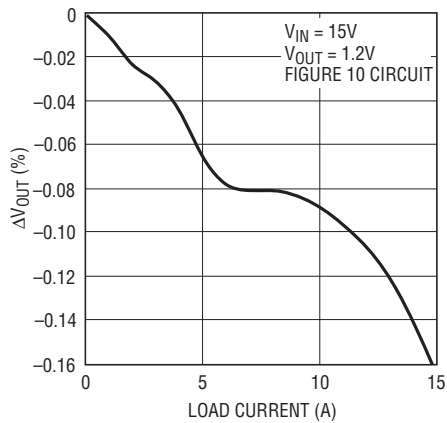

3879 G16

I_{TH} Voltage vs Load Current

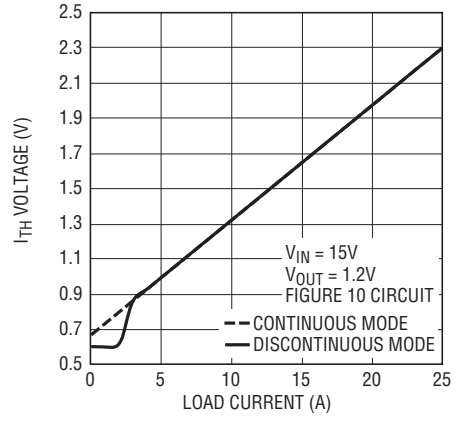

3879 G17

TYPICAL PERFORMANCE CHARACTERISTICS

Error Amplifier g_m vs Temperature

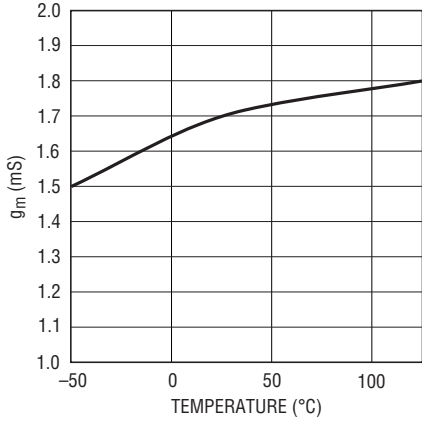

3879 G18

Shutdown Current vs Input Voltage

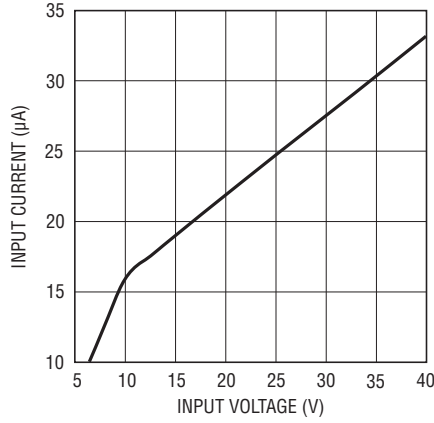

3879 G19

Quiescent Current vs INTV_{CC}

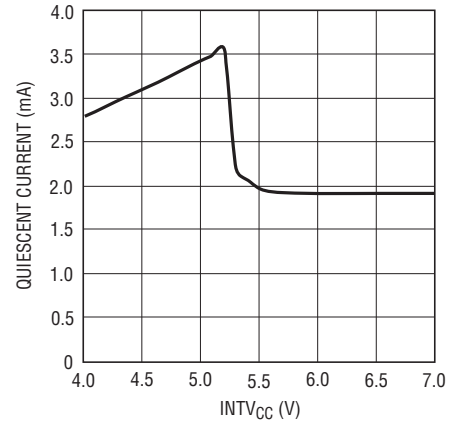

3879 G20

INTV_{CC} Load Regulation

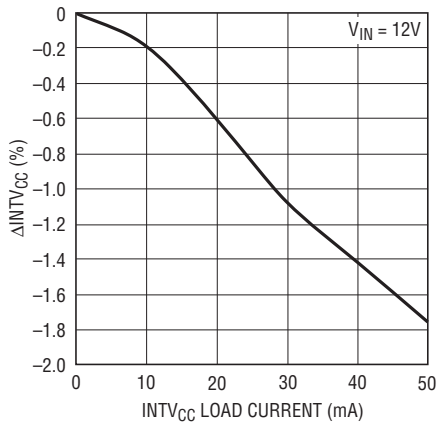

3879 G21

INTV_{CC} Dropout

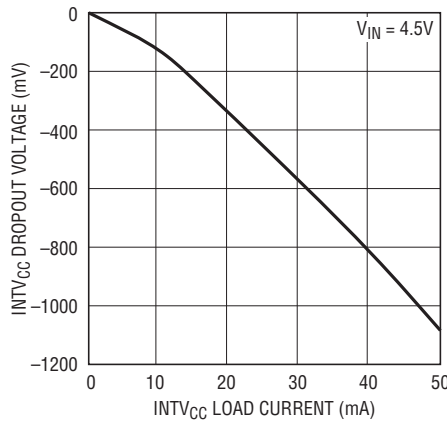

3879 G22

INTV_{CC} vs INTV_{CC} I_{LOAD}

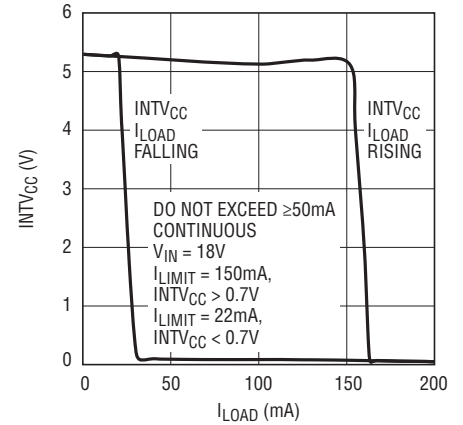

3879 G23

TRACK/SS Pin Current vs Temperature

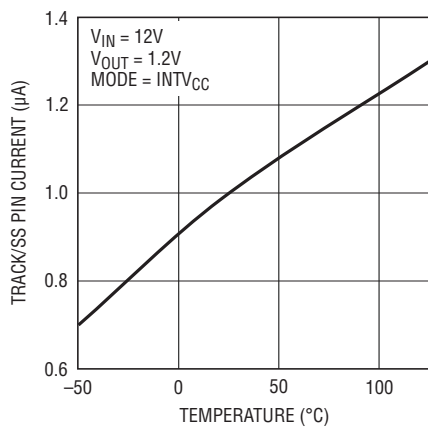

3879 G24

Feedback Reference Voltage vs Temperature

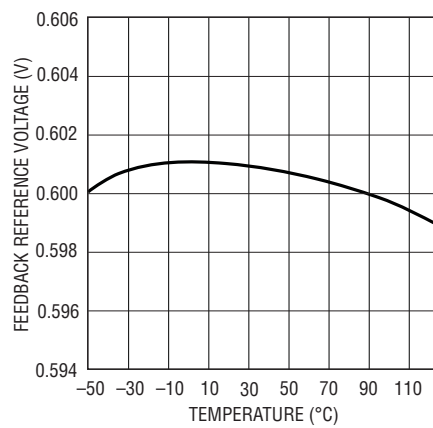

3879 G25

PIN FUNCTIONS

TRACK/SS (Pin 1): External Tracking and Soft-Start Input. The LTC3879 regulates V_{FB} to the smaller of 0.6V or the voltage on the TRACK/SS pin. An internal $1\mu\text{A}$ pull-up current source is connected to this pin. A capacitor to ground at this pin sets the ramp time to the final regulated output voltage. Alternatively, a resistor divider on another voltage supply connected to this pin allows the output to track the other supply during start-up.

PGOOD (Pin 2): Power Good Output. This open-drain logic output is pulled to ground when the output voltage is outside of a $\pm 10\%$ window around the regulation point.

V_{RNG} (Pin 3): V_{DS} Sense Voltage Range Input. The maximum allowed bottom MOSFET V_{DS} sense voltage between SW and PGND is equal to $(0.133)V_{RNG}$. The voltage applied to V_{RNG} can be any value between 0.2V and 2V. If V_{RNG} is tied to SGND, the device operates with a maximum valley current sense threshold of 30mV typical. If V_{RNG} is tied to INTV_{CC}, the device operates with a maximum valley current sense threshold of 75mV typical.

MODE (Pin 4): MODE Input. Connect this pin to INTV_{CC} to enable discontinuous mode for light load operation. Connect this pin to SGND to force continuous mode operation in all conditions.

I_{TH} (Pin 5): Current Control Threshold and Error Amplifier Compensation Point. The current comparator threshold increases with this control voltage. The voltage ranges from 0V to 2.4V, with 0.8V corresponding to zero sense voltage (zero current).

SGND (Pin 6): Signal Ground. All small-signal components should be connected to SGND. Connect SGND to PGND using a single PCB trace.

I_{ON} (Pin 7): On-Time Current Input. Tie a resistor from V_{IN} to this pin to set the one-shot timer current and thus the switching frequency.

V_{FB} (Pin 8): Error Amplifier Feedback Input. This pin connects the error amplifier to an external resistive divider from V_{OUT} .

RUN (Pin 9): Run Control Input. RUN below 1.5V disables switching by forcing TG and BG low. RUN less than 1.5V but greater than 0.7V enables all internal bias including the INTV_{CC} output. RUN below 0.7V shuts down all bias and places the LTC3879 into micropower shutdown mode of approximately $18\mu\text{A}$. There is an internal $1.2\mu\text{A}$ pull-up current source for operation with an open-collector RUN signal.

V_{IN} (Pin 10): Main Input Supply. The supply voltage can range from 4V to 38V. For increased noise immunity decouple this pin to PGND with an RC filter.

INTV_{CC} (Pin 11): Internal 5.3V Regulator Output. The driver and control circuits are powered from this voltage. Decouple this pin to PGND with a minimum of $1\mu\text{F}$, 10V X5R or X7R ceramic capacitor.

BG (Pin 12): Bottom Gate Drive. This pin drives the gate of the bottom N-Channel power MOSFET between PGND and INTV_{CC}.

PGND (Pin 13): Power Ground. Connect this pin as close as practical to the source of the bottom N-channel power MOSFET, the (–) terminal of C_{INTVCC} and the (–) terminal of C_{VIN} .

SW (Pin 14): Switch Node. The (–) terminal of the bootstrap capacitor, C_B , connects to this node. This pin swings from a diode voltage below ground up to V_{IN} .

TG (Pin 15): Top Gate Drive. This pin drives the gate of the top N-channel power MOSFET between SW and BOOST.

BOOST (Pin 16): Boosted Floating Driver Supply. The (+) terminal of the bootstrap capacitor, C_B , connects to this node. This node swings from $(INTV_{CC} - V_{SCHOTTKY})$ to $V_{IN} + (INTV_{CC} - V_{SCHOTTKY})$.

Exposed Pad (Pin 17): The Exposed Pad is SGND and must be soldered to the PCB.

FUNCTIONAL DIAGRAM

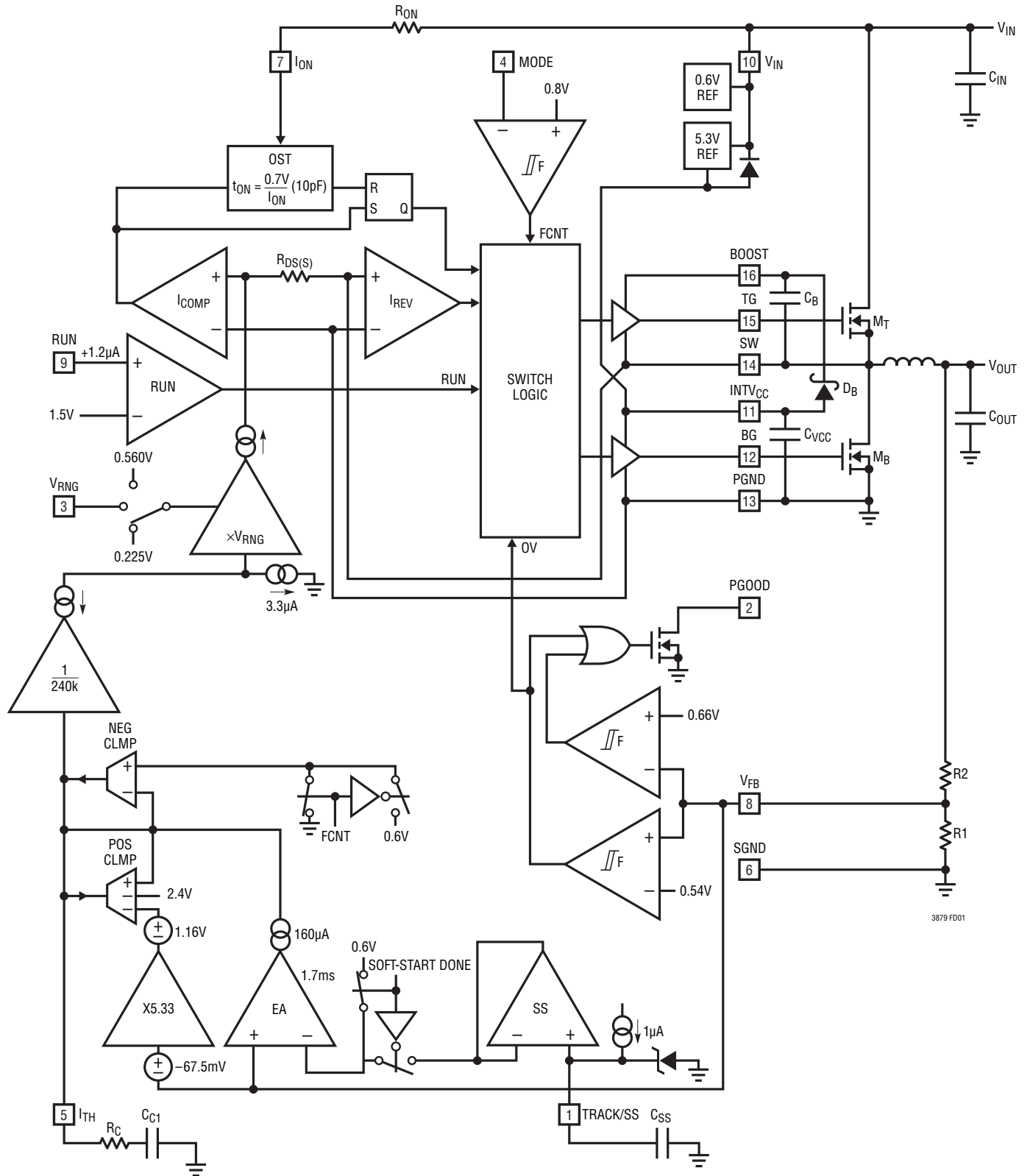

3879 FD01

OPERATION

Main Control Loop

The LTC3879 is a valley current mode controller IC for use in DC/DC step-down converters. In normal continuous operation, the top MOSFET is turned on for a fixed interval determined by a one-shot timer, OST. When the top MOSFET is turned off, the bottom MOSFET is turned on until the current comparator, I_{CMP} , trips, restarting the one-shot timer and initiating the next cycle. Inductor valley current is measured by sensing the voltage between the PGND and SW pins using the bottom MOSFET on-resistance. The voltage on the I_{TH} pin sets the comparator threshold corresponding to inductor valley current. The error amplifier EA adjusts this voltage by comparing the feedback signal V_{FB} from the output voltage to the feedback reference voltage V_{FBREF} . Increasing the load current causes a drop in the feedback voltage relative to the reference. The EA senses the feedback voltage drop and adjusts the I_{TH} voltage higher until the average inductor current matches the load current.

With DC current loads less than 1/2 of the peak-to-peak ripple the inductor current can drop to zero or become negative. In discontinuous operation, negative inductor current is detected and prevented by the current reversal comparator I_{REV} , which shuts off MB. Both switches remain off with the output capacitor supplying the load current until the EA moves the I_{TH} voltage above the zero current level (0.8V) to initiate another switching cycle. When the MODE pin is below the internal threshold reference, V_{MODE} ,

the regulator is forced to operate in continuous mode by disabling reversal comparator, I_{REV} , thereby allowing the inductor current to become negative.

The continuous mode operating frequency can be determined by dividing the calculated duty cycle, V_{OUT}/V_{IN} , by the fixed on-time. The OST generates an on-time proportional to the ideal duty cycle, thus holding the frequency approximately constant with changes in V_{IN} . The nominal frequency can be adjusted with an external resistor, R_{ON} .

Foldback current limiting is provided to protect against low impedance shorts. If the controller is in current limit and V_{OUT} drops to less 50% of regulation, the current limit set-point “folds back” to progressively lower values. To recover from foldback current limit, the excessive load or low impedance short needs to be removed.

When RUN is less than 0.7V, the LTC3879 is in the low power shutdown state with a nominal bias current of 18 μ A. When RUN is greater than 0.7V and less than 1.5V, $INTV_{CC}$ and all internal circuitry are enabled while TG and BG are forced low. When RUN is taken greater than 1.5V, switching begins and the TRACK/SS pin is released from ground. The output voltage follows the TRACK/SS input multiplied by feedback factor when TRACK/SS is less than 0.6V. Soft-start is complete when TRACK/SS exceeds the internal 0.6V reference voltage and regulates normally.

APPLICATIONS INFORMATION

The basic LTC3879 application circuit is shown on the first page of this data sheet. External component selection is largely determined by maximum load current and begins with the selection of sense resistance and power MOSFET switches. The LTC3879 uses the on-resistance of the synchronous power MOSFET to determine the inductor current. The desired ripple current and operating frequency largely determines the inductor value. Finally, C_{IN} is selected for its ability to handle the large RMS current into the converter, and C_{OUT} is chosen with low enough ESR to meet output voltage ripple and transient specifications.

Maximum V_{DS} Sense Voltage and V_{RNG} Pin

Inductor current is measured by sensing the bottom MOSFET V_{DS} voltage that appears between the PGND and SW pins. The maximum allowed V_{DS} sense voltage is set by the voltage applied to the V_{RNG} pin and is approximately equal to $(0.133)V_{RNG}$. The current mode control loop does not allow the inductor current valleys to exceed $(0.133)V_{RNG}$. In practice, one should allow margin, to account for variations in the LTC3879 and external component values. A good guide for setting V_{RNG} is:

$$V_{RNG} = 7.5 \cdot (\text{Maximum } V_{DS} \text{ Sense Voltage})$$

An external resistive divider from $INTV_{CC}$ can be used to set the voltage on the V_{RNG} pin between 0.2V and 2V, resulting in peak sense voltages between 26.6mV and 266mV. The wide peak voltage sense range allows for a variety of applications and MOSFET choices. The V_{RNG} pin can also be tied to either SGND or $INTV_{CC}$ to force internal defaults. When V_{RNG} is tied to SGND, the device operates at a valley current sense threshold of 30mV typical. If V_{RNG} is tied to $INTV_{CC}$, the device operates at a valley current sense threshold of 75mV typical.

Power MOSFET Selection

The LTC3879 requires two external N-channel power MOSFETs, one for the top (main) switch and one for the bottom (synchronous) switch. Important parameters for the power MOSFETs are the breakdown voltage $V_{BR(DSS)}$, threshold voltage $V_{GS(TH)}$, on-resistance $R_{DS(ON)}$, reverse transfer capacitance C_{RSS} and maximum current $I_{DS(MAX)}$.

The gate drive voltages are set by the 5.3V $INTV_{CC}$ supply. Consequently, logic-level threshold MOSFETs must be used in LTC3879 applications. If the input voltage is expected to drop below 5V, then sub-logic level threshold MOSFETs should be considered.

Using the bottom MOSFET as the current sense element requires particular attention be paid to its on-resistance. MOSFET on-resistance is typically specified with a maximum value $R_{DS(ON)(MAX)}$ at 25°C. In this case additional margin is required to accommodate the rise in MOSFET on-resistance with temperature.

$$R_{DS(ON)(MAX)} = \frac{\text{Max } V_{DS} \text{ Sense Voltage}}{I_0 \cdot \rho_T}$$

The ρ_T term is a normalization factor (unity at 25°C) accounting for the significant variation in on-resistance with temperature, typically about 0.4%/°C, as shown in Figure 1. For a maximum junction temperature of 100°C using a value of $\rho_T = 1.3$ is reasonable.

The power dissipated by the top and bottom MOSFETs depends upon their respective duty cycles and the load current. When the LTC3879 is operating in continuous mode, the duty cycles for the MOSFETs are:

$$D_{TOP} = \frac{V_{OUT}}{V_{IN}}$$

$$D_{BOT} = \frac{V_{IN} - V_{OUT}}{V_{IN}}$$

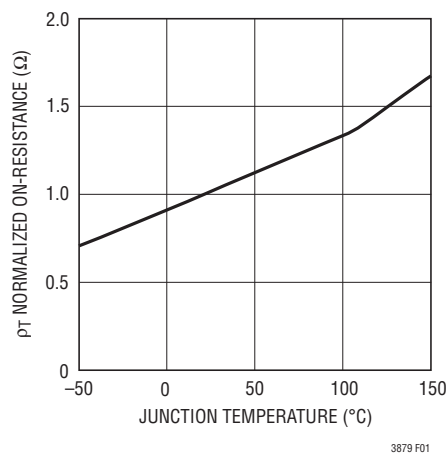

Figure 1. $R_{DS(ON)}$ vs Temperature

APPLICATIONS INFORMATION

The resulting power dissipation in the MOSFETs at maximum output current are:

$$P_{TOP} = D_{TOP} \cdot I_{OUT(MAX)}^2 \cdot \rho_{\tau(TOP)} \cdot R_{DS(ON)(MAX)} + V_{IN}^2 \left(\frac{I_{OUT(MAX)}}{2} \right) (C_{MILLER})$$

$$\left[\frac{DR_{TGHIGH}}{V_{INTVCC} - V_{MILLER}} + \frac{DR_{TGLow}}{V_{MILLER}} \right] f_{OSC}$$

$$P_{BOT} = D_{BOT} \cdot I_{OUT(MAX)}^2 \cdot \rho_{\tau(BOT)} \cdot R_{DS(ON)(MAX)}$$

DR_{TGHIGH} is pull-up driver resistance and DR_{TGLow} is the TG driver pull-down resistance. V_{MILLER} is the Miller effect V_{GS} voltage and is taken graphically from the power MOSFET data sheet.

MOSFET input capacitance is a combination of several components but can be taken from the typical “gate charge” curve included on the most data sheets (Figure 2). The curve is generated by forcing a constant input current into the gate of a common source, current source, loaded stage and then plotting the gate versus time. The initial slope is the effect of the gate-to-source and gate-to-drain capacitance. The flat portion of the curve is the result of the Miller multiplication effect of the drain-to-gate capacitance as the drain drops the voltage across the current source load. The upper sloping line is due to the drain-to-gate accumulation capacitance and the gate-to-source capacitance. The Miller charge (the increase in coulombs on the horizontal axis from a to b while the curve is flat) is specified from a given V_{DS} drain voltage, but can be adjusted for different V_{DS} voltages by multiplying by the ratio of the application V_{DS} to the curve specified V_{DS} values. A way to estimate the C_{MILLER} term is to take the change in gate charge from points a and b or the parameter Q_{GD} on a manufacturers data sheet and divide by the specified V_{DS} test voltage, $V_{DS(TEST)}$.

$$C_{MILLER} = \frac{Q_{GD}}{V_{DS(TEST)}}$$

C_{MILLER} is the most important selection criteria for determining the transition loss term in the top MOSFET but is not directly specified on MOSFET data sheets.

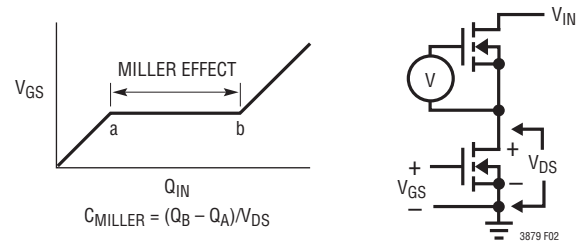

Figure 2. Gate Charge Characteristic

Both MOSFETs have I^2R power loss, and the top MOSFET includes an additional term for transition loss, which are highest at high input voltages. For $V_{IN} < 20V$, the high current efficiency generally improves with larger MOSFETs, while for $V_{IN} > 20V$, the transition losses rapidly increase to the point that the use of a higher $R_{DS(ON)}$ device with lower C_{MILLER} actually provides higher efficiency. The synchronous MOSFET losses are greatest at high input voltage when the top switch duty factor is low or during a short-circuit when the synchronous switch is on close to 100% of the period.

Operating Frequency

The choice of operating frequency is a tradeoff between efficiency and component size. Lowering the operating frequency improves efficiency by reducing MOSFET switching losses but requires larger inductance and/or capacitance to maintain low output ripple voltage. Conversely, raising the operating frequency degrades efficiency but reduces component size.

The operating frequency of LTC3879 applications is determined implicitly by the one-shot timer that controls the on-time, t_{ON} , of the top MOSFET switch. The on-time is set by the current into the I_{ON} pin according to:

$$t_{ON} = \frac{0.7V}{I_{ION}} (10pF)$$

Tying a resistor R_{ON} from V_{IN} to the I_{ON} pin yields an on-time inversely proportional to V_{IN} . For a step-down converter, this results in pseudo fixed frequency operation as the input supply varies.

$$f_{OP} = \frac{V_{OUT}}{0.7V \cdot R_{ON} (10pF)} [Hz]$$

APPLICATIONS INFORMATION

Figure 3 shows how R_{ON} relates to switching frequency for several common output voltages.

When designing for pseudo fixed frequency, there is systematic error because the I_{ON} pin voltage is approximately 0.7V, not zero. This causes the I_{ON} current to be inversely proportional to $(V_{IN} - 0.7V)$ and not V_{IN} . The I_{ON} current error increases as V_{IN} decreases. To correct this error, an additional resistor R_{ON2} can be connected from the I_{ON} pin to the 5.3V $INTV_{CC}$ supply.

$$R_{ON2} = \frac{5.3V - 0.7V}{0.7V} R_{ON}$$

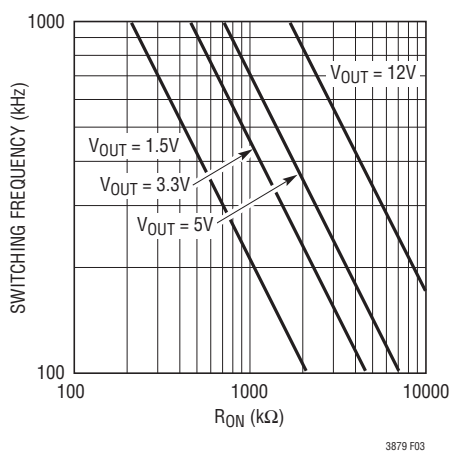

Figure 3. Switching Frequency vs R_{ON}

Minimum Off-Time and Dropout Operation

The minimum off-time, $t_{OFF(MIN)}$, is the shortest time required for the LTC3879 to turn on the bottom MOSFET, trip the current comparator and then turn off the bottom MOSFET. This time is typically about 220ns. The minimum off-time limit imposes a maximum duty cycle of $t_{ON} / (t_{ON} + t_{OFF(MIN)})$. If the maximum duty cycle is reached, due to a drooping input voltage for example, then the output will drop out of regulation. The minimum input voltage to avoid dropout is:

$$V_{IN(MIN)} = V_{OUT} \frac{t_{ON} + t_{OFF(MIN)}}{t_{ON}}$$

A plot of maximum duty cycle vs. frequency is shown in Figure 4.

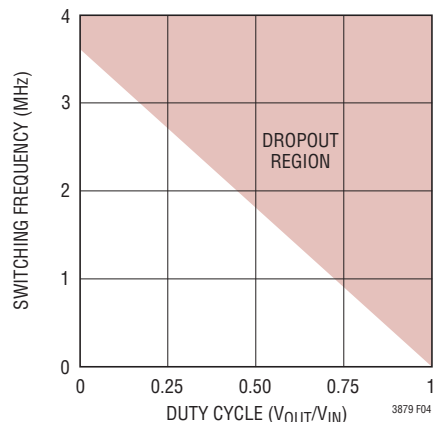

Figure 4. Maximum Switching Frequency vs Duty Cycle

Likewise, the maximum frequency of operation is determined by the fixed on-time, t_{ON} , and the minimum off-time, $t_{OFF(MIN)}$. The fixed on-time is determined by dividing the duty factor by the nominal frequency of operation:

$$f_{MAX} = \frac{1}{\frac{V_{OUT}}{V_{IN}} \cdot f_{OP} + t_{OFF(MIN)}} \text{ [Hz]}$$

The LTC3879 is a PFM (pulse frequency mode) regulator where pulse density is modulated, not pulse width. Consequently, frequency increases with a load step and decreases with a load release. The steady-state operating frequency, f_{OP} , should be set sufficiently below f_{MAX} to allow for device tolerances and transient response.

Inductor Value Calculation

Given the desired input and output voltages, the inductor value and operation frequency determine the ripple current:

$$\Delta I_L = \left(\frac{V_{OUT}}{f_{OP} \cdot L} \right) \left(1 - \frac{V_{OUT}}{V_{IN}} \right)$$

Lower ripple current reduces core losses in the inductor, ESR losses in the output capacitors and output voltage ripple. Highest efficiency operation is obtained at low frequency with small ripple current. However, achieving this requires a large inductor. There is a tradeoff between component size, efficiency and operating frequency.

APPLICATIONS INFORMATION

A reasonable starting point is to choose a ripple current that is about 40% of $I_{OUT(MAX)}$. The largest ripple current occurs at the highest V_{IN} . To guarantee that ripple current does not exceed a specified maximum, the inductance should be chosen according to:

$$L = \left(\frac{V_{OUT}}{f_{OP} \cdot \Delta I_{L(MAX)}} \right) \left(1 - \frac{V_{OUT}}{V_{IN(MAX)}} \right)$$

Once the value for L is known, the type of inductor must be selected. High efficiency converters generally cannot tolerate the core loss of low cost powdered iron cores, forcing the use of more expensive ferrite materials such as molypermalloy or Kool M μ ® cores. A variety of inductors designed for high current, low voltage applications are available from manufacturers such as Sumida, Panasonic, Coiltronics, Coilcraft, Toko, Vishay, Pulse and Würth.

Inductor Core Selection

Once the inductance value is determined, the type of inductor must be selected. Core loss is independent of core size for a fixed inductor value, but it is very dependent on inductance selected. As inductance increases, core losses go down. Unfortunately, increased inductance requires more turns of wire and therefore copper losses will increase.

Ferrite designs have very low core loss and are preferred at high switching frequencies, so design goals can concentrate on copper loss and preventing saturation. Ferrite core material saturates “hard,” which means that inductance collapses abruptly when the peak design current is exceeded. This results in an abrupt increase in inductor ripple current and consequent output voltage ripple. Do not allow the core to saturate!

C_{IN} and C_{OUT} Selection

The input capacitance C_{IN} is required to filter the square wave current at the drain of the top MOSFET. Use a low ESR capacitor sized to handle the maximum RMS current.

$$I_{RMS} \cong I_{OUT(MAX)} \cdot \frac{V_{OUT}}{V_{IN}} \cdot \sqrt{\frac{V_{IN}}{V_{OUT}} - 1}$$

This formula has a maximum at $V_{IN} = 2V_{OUT}$, where $I_{RMS} = I_{OUT(MAX)}/2$. This simple worst-case condition is commonly used for design because even significant deviations do not offer much relief. Note that ripple current ratings from capacitor manufacturers are often based on only 2000 hours of life, which makes it advisable to de-rate the capacitor.

The selection of C_{OUT} is primarily determined by the ESR required to minimize voltage ripple and load step transients. The ΔV_{OUT} is approximately bounded by:

$$\Delta V_{OUT} \leq \Delta I_L \left(ESR + \frac{1}{8 \cdot f_{OP} \cdot C_{OUT}} \right)$$

Since ΔI_L increases with input voltage, the output ripple is highest at maximum input voltage. Typically, once the ESR requirement is satisfied, the capacitance is adequate for filtering and has the necessary RMS current rating.

Multiple capacitors placed in parallel may be needed to meet the ESR and RMS current handling requirements. Dry tantalum, specialty polymer, aluminum electrolytic and ceramic capacitors are all available in surface mount packages. Specialty polymer capacitors offer very low ESR but have lower specific capacitance than other types. Tantalum capacitors have the highest specific capacitance but it is important to only use types that have been surge tested for use in switching power supplies. Aluminum electrolytic capacitors have significantly higher ESR, but can be used in cost-sensitive applications providing that consideration is given to ripple current ratings and long-term reliability. Ceramic capacitors have excellent low ESR characteristics but can have a high voltage coefficient and audible piezoelectric effects. The high Q of ceramic capacitors with trace inductance can also lead to significant ringing. When used as input capacitors, care must be taken to ensure that ringing from inrush currents and switching does not pose an overvoltage hazard to the power switches and controller. To dampen input voltage transients, add a small 5 μ F to 40 μ F aluminum electrolytic capacitor with an ESR in the range of 0.5 Ω to 2 Ω . High performance through-hole capacitors may also be used, but an additional ceramic capacitor in parallel is recommended to reduce the effect of lead inductance.

APPLICATIONS INFORMATION

Top MOSFET Driver Supply (C_B , D_B)

An external bootstrap capacitor, C_B , connected to the BOOST pin supplies the gate drive voltage for the topside MOSFET. This capacitor is charged through diode D_B from $INTV_{CC}$ when the switch node is low. When the top MOSFET turns on, the switch node rises to V_{IN} and the BOOST pin rises to approximately $V_{IN} + INTV_{CC}$. The boost capacitor needs to store approximately 100 times the gate charge required by the top MOSFET. In most applications 0.1 μ F to 0.47 μ F, X5R or X7R dielectric capacitor is adequate.

It is recommended that the BOOST capacitor be no larger than 10% of the $INTV_{CC}$ capacitor C_{VCC} , to ensure that the C_{VCC} can supply the upper MOSFET gate charge and BOOST capacitor under all operating conditions. Variable frequency in response to load steps offers superior transient performance but requires higher instantaneous gate drive. Gate charge demands are greatest in high frequency low duty factor applications under high di/dt load steps and at start-up.

Setting Output Voltage

The LTC3879 output voltage is set by an external feedback resistive divider carefully placed across the output, as shown in Figure 5. The regulated output voltage is determined by:

$$V_{OUT} = 0.6V \left(1 + \frac{R_B}{R_A} \right)$$

To improve the transient response, a feed-forward capacitor, C_{FF} , may be used. Great care should be taken to route the V_{FB} line away from noise sources, such as the inductor or the SW line.

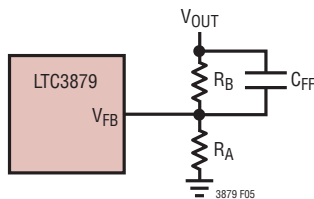

Figure 5. Setting Output Voltage

Discontinuous Mode Operation and MODE Pin

The MODE pin determines whether the LTC3879 operates in forced continuous mode or allows discontinuous conduction mode. Tying this pin above 0.8V enables discontinuous operation, where the bottom MOSFET turns off when the inductor current reverses polarity. The load current at which current reverses and discontinuous operation begins depends on the amplitude of the inductor ripple current and will vary with changes in V_{IN} . In steady-state operation, discontinuous conduction mode occurs for DC load currents less than 1/2 the peak-to-peak ripple current. Tying the MODE pin below the 0.8V threshold forces continuous switching, where inductor current is allowed to reverse at light loads and maintain synchronous switching.

In addition to providing a logic input to force continuous operation, the MODE pin provides a means to maintain a fly back winding output when the primary is operating in discontinuous mode. The secondary output V_{OUT2} is normally set as shown in Figure 6 by the turns ratio N of the transformer. However, if the controller goes into discontinuous mode and halts switching due to a light primary load current, then V_{OUT2} will droop. An external resistor divider from V_{OUT2} to the MODE pin sets a minimum voltage $V_{OUT2(MIN)}$ below which continuous operation is forced until V_{OUT2} has risen above its minimum.

$$V_{OUT2(MIN)} = 0.8V \left(1 + \frac{R_4}{R_3} \right)$$

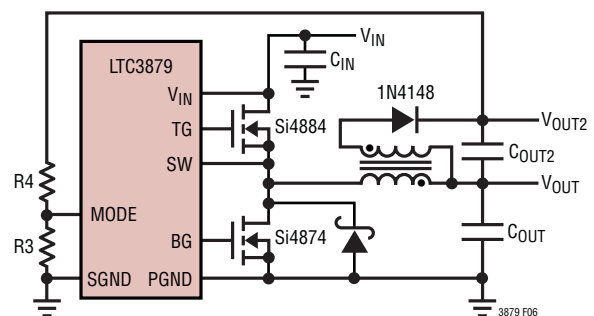

Figure 6. Secondary Output Loop

APPLICATIONS INFORMATION

Fault Conditions: Current Limit and Foldback

The maximum inductor current is inherently limited in a current mode controller by the maximum sense voltage. In the LTC3879, the maximum sense voltage is controlled by the voltage on the V_{RNG} pin. With valley current mode control, the maximum sense voltage and the sense resistance determine the maximum allowed inductor valley current. The corresponding output current limit is:

$$I_{\text{LIMIT}} = \frac{V_{\text{SNS(MAX)}}}{R_{\text{DS(ON)}} \cdot \rho_T} + \frac{1}{2} \cdot \Delta I_L$$

The current limit value should be checked to ensure that $I_{\text{LIMIT(MIN)}} > I_{\text{OUT(MAX)}}$. The current limit value should be greater than the inductor current required to produce maximum output power at the worst-case efficiency. Worst-case efficiency typically occurs at the highest V_{IN} and highest ambient temperature. It is important to check for consistency between the assumed MOSFET junction temperatures and the resulting value of I_{LIMIT} which heats the MOSFET switches.

Caution should be used when setting the current limit based on the $R_{\text{DS(ON)}}$ of the MOSFETs. The maximum current limit is determined by the minimum MOSFET on-resistance. Data sheets typically specify nominal and maximum values for $R_{\text{DS(ON)}}$ but not a minimum. A reasonable assumption is that the minimum $R_{\text{DS(ON)}}$ lies the same amount below the typical value as the maximum lies above it. Consult the MOSFET manufacturer for further guidelines.

To further limit current in the event of a short circuit to ground, the LTC3879 includes foldback current limiting. If the output falls by more than 50%, then the maximum sense voltage is progressively lowered to about one-sixth of its full value.

INTV_{CC} Regulator

An internal P-channel low dropout regulator produces the 5.3V supply that powers the drivers and internal circuitry within the LTC3879. The INTV_{CC} pin can supply up to 50mA RMS and must be bypassed to ground with a minimum of 1 μ F low ESR tantalum or ceramic capacitor (10V, X5R or X7R). Output capacitance greater than 10 μ F is discouraged. Good bypassing is necessary to supply the high transient currents required by the MOSFET gate drivers.

Applications using large MOSFETs with a high input voltage and high frequency of operation may cause the LTC3879 to exceed its maximum junction temperature rating or RMS current rating. In continuous mode operation, this current is $I_{\text{GATECHG}} = f_{\text{OP}}(Q_{\text{g(TOP)}} + Q_{\text{g(BOT)}})$. The junction temperature can be estimated from the equations given in Note 2 of the Electrical Characteristics. For example, with a 30V input supply, the LTC3879 in the MSE16 is limited to less than:

$$T_J = 70^\circ\text{C} + (46\text{mA})(30)(40^\circ\text{C/W}) = 125^\circ\text{C}$$

Using the INTV_{CC} regulator to supply external loads greater than 5mA is discouraged. INTV_{CC} is designed to supply the LTC3879 with minimal external loading. When using the regulator to supply larger external loads, carefully consider all operating load conditions. During load steps and soft-start, transient current requirements significantly exceed the RMS values. Additional loading on INTV_{CC} takes away from the drive available to source gate charge during high frequency transient load steps.

Soft-Start with the TRACK/SS Pin

The LTC3879 has the ability to either soft-start by itself with a capacitor or track the output of another channel or external supply. When the LTC3879 is configured to soft-start by itself, a capacitor should be connected to the TRACK/SS pin. The LTC3879 is in the shutdown state when the RUN pin is below 0.7V. When RUN is greater than 0.7V but less than 1.5V, all internal circuitry is enabled while M_T and M_B are forced off. The TRACK/SS pin is actively pulled to ground when RUN is less than 1.5V.

When the RUN pin voltage is greater than 1.5V, the LTC3879 powers up. When not tracking, a soft-start current of 1 μ A is used to charge a soft-start capacitor placed on the TRACK/SS pin. Note that soft-start or tracking is achieved not by limiting the maximum output current of the controller, but instead by controlling the output voltage according to the ramp rate on the TRACK/SS pin. Current foldback is disabled during start-up to ensure smooth soft-start or tracking. The soft-start or tracking range is determined to be the voltage range from 0V to 0.6V on the TRACK/SS pin.

$$t_{\text{SOFT-START}} = 0.6 \cdot \frac{C_{\text{SS}}}{1\mu\text{A}}$$

APPLICATIONS INFORMATION

The LTC3879 is designed to start up into pre-biased outputs with no reverse current. Both TG and BG outputs remain low until the applied TRACK/SS voltage plus internal offset exceeds the voltage on the V_{FB} pin. Once this condition is exceeded, the switcher will start up normally and track the TRACK/SS voltage until it exceeds 0.6V. Once switching starts, the mode of operation is determined by the externally programmed MODE pin input. When TRACK/SS exceeds 0.6V, the output regulates to the internal reference value of 0.6V.

When the regulator is configured to track another supply, the feedback voltage of the other supply is duplicated by a resistor divider and applied to the TRACK/SS pin. Therefore, the voltage ramp rate on this pin is determined by the ramp rate of the other supply's voltage. Note that the small soft-start capacitor charging current is always flowing, producing a small offset error. To minimize this error, one can select the tracking resistive divider value to be small enough to make this error negligible.

In order to track down another supply after the soft-start phase expires, the LTC3879 must be configured for forced continuous operation.

Output Voltage Tracking

The LTC3879 allows the user to program how its output ramps up and down by means of the TRACK/SS pin. Through this pin, the output can be set up to either coincidentally or ratiometrically track with another supply's output, as shown in Figure 7. In the following discussions, V_{MASTER} refers to a master supply and V_{OUT} refers to the LTC3879's output as a slave supply. To implement the coincident tracking in Figure 7, connect a resistor divider to the V_{MASTER} , and connect its midpoint to the TRACK/SS pin of the LTC3879. The track divider should be the same as the LTC3879's feedback divider. In this tracking mode, V_{OUT_MASTER} must be higher than V_{OUT} . To implement ratiometric tracking, the ratio of the resistor divider connected to V_{OUT_MASTER} is determined by:

$$\frac{V_{OUT_MASTER}}{0.6V} = \frac{R3 + R4}{R4}$$

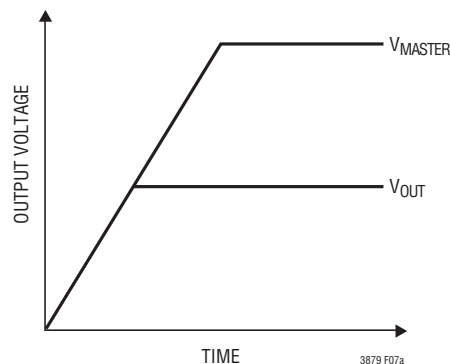

(7a) Coincident Tracking

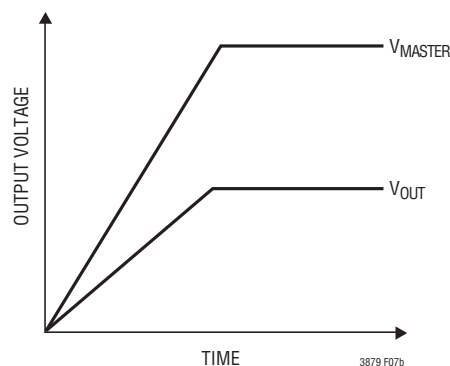

(7b) Ratiometric Tracking

Figure 7. Two Different Modes of Output Voltage Tracking

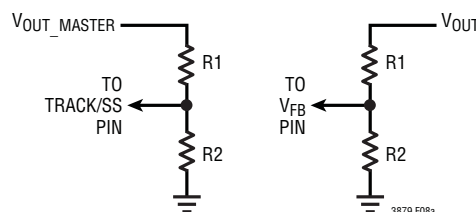

(8a) Coincident Tracking Setup

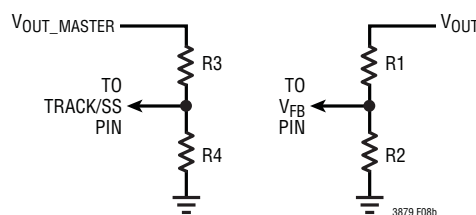

(8b) Ratiometric Tracking Setup

Figure 8. Setup for Coincident and Ratiometric Tracking

APPLICATIONS INFORMATION

So, which mode should be programmed? While either mode in Figure 8 satisfies most practical applications, the coincident mode offers better output regulation. This can be better understood with the help of Figure 9. At the input stage of the LTC3879's error amplifier, two common anode diodes are used to clamp the equivalent reference voltage and an additional diode is used to match the shifted common mode voltage. The top two current sources are of the same amplifier. In the coincident mode, the TRACK/SS voltage is substantially higher than 0.6V at steady-state and effectively turns off D1. D2 and D3 will, therefore, conduct the same current, and offer tight matching between V_{FB} and the internal precision 0.6V reference. In the ratiometric mode, however, TRACK/SS equals 0.6V in steady-state. D1 will divert part of the bias current to make V_{FB} slightly lower than 0.6V.

Although this error is minimized by the exponential I-V characteristics of the diode, it does impose a finite amount of output voltage deviation. Furthermore, when the master supply's output experiences dynamic excursion (under load transient, for example), the slave channel output will be affected as well. For better output regulation, use the coincident tracking mode instead of ratiometric.

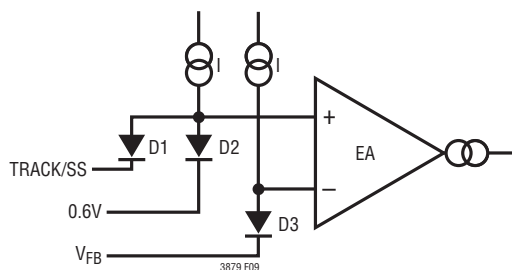

Figure 9. Equivalent Input Circuit of Error Amplifier

INTV_{CC} Undervoltage Lockout

Whenever INTV_{CC} drops below approximately 3.4V, the device enters undervoltage lockout (UVLO). In a UVLO condition, the switching outputs TG and BG are disabled. At the same time, the TRACK/SS pin is pulled down from

INTV_{CC} to 0V with a small internal NMOS switch. When the INTV_{CC} UVLO condition is removed, TRACK/SS is released, beginning a normal soft-start. This feature is important when regulator start-up is not initiated by applying a logic drive to RUN.

Efficiency Considerations

The percent efficiency of a switching regulator is equal to the output power divided by the input power times 100%. It is often useful to analyze individual losses to determine what is limiting the efficiency and which change would produce the most improvement. Although all dissipative elements in the circuit produce losses, four main sources account for most of the losses in LTC3879 circuits.

1. DC I^2R losses. These arise from the resistances of the MOSFETs, inductor and PC board traces and cause the efficiency to drop at high output currents. In continuous mode the average output current flows through the inductor L, but is chopped between the top and bottom MOSFETs. If the two MOSFETs have approximately the same $R_{DS(ON)}$, then the resistance of one MOSFET can simply be summed with the resistances of L and the board traces to obtain the DC I^2R loss. For example, if $R_{DS(ON)} = 0.01\Omega$ and $R_L = 0.005\Omega$, the loss will range from 15mW to 1.5W as the output current varies from 1A to 10A.
2. Transition loss. This loss arises from the brief amount of time the top MOSFET spends in the saturated region during switch node transitions. It depends upon the input voltage, load current, driver strength and MOSFET capacitance, among other factors. The loss is significant at input voltages above 20V.
3. INTV_{CC} current. This is the sum of the MOSFET driver and control currents.
4. C_{IN} loss. The input capacitor has the difficult job of filtering the large RMS input current to the regulator. It must have a very low ESR to minimize the AC I^2R loss and sufficient capacitance to prevent the RMS current from causing additional upstream losses in fuses or batteries.

APPLICATIONS INFORMATION

Other losses, which include the C_{OUT} ESR loss, bottom MOSFET reverse recovery loss and inductor core loss generally account for less than 2% additional loss.

When making adjustments to improve efficiency, the input current is the best indicator of changes in efficiency. If you make a change and the input current decreases, then the efficiency has increased. If there is no change in input current there is no change in efficiency.

Checking Transient Response

The regulator loop response can be checked by looking at the load transient response. Switching regulators take several cycles to respond to a step in load current. When a load step occurs, V_{OUT} immediately shifts by an amount equal to ΔI_{LOAD} (ESR), where ESR is the effective series resistance of C_{OUT} . ΔI_{LOAD} also begins to charge or discharge C_{OUT} , generating a feedback error signal used by the regulator to return V_{OUT} to its steady-state value. During this recovery time, V_{OUT} can be monitored for overshoot or ringing that would indicate a stability problem. The I_{TH} pin external components shown in the Design Example will provide adequate compensation for most applications.

A rough compensation check can be made by calculating the gain crossover frequency, f_{GCO} . $g_{m(EA)}$ is the error amplifier transconductance, R_C is the compensation resistor and feedback divider attenuation is assumed to be $0.6V/V_{OUT}$. This equation assumes that no feed-forward compensation is used on feedback and that C_{OUT} sets the dominant output pole.

$$f_{GCO} = g_{m(EA)} \cdot R_C \cdot \frac{I_{LIMIT}}{1.6} \cdot \frac{1}{2 \cdot \pi \cdot C_{OUT}} \cdot \frac{0.6}{V_{OUT}}$$

As a rule of thumb the gain crossover frequency should be less than 20% of the switching frequency. For a detailed explanation of switching control loop theory see Application Note 76.

High Switching Frequency Operation

Special care should be taken when operating at switching frequencies greater than 800kHz. At high switching frequencies there may be an increased sensitivity to PCB noise which may result in off-time variation greater than normal. This off-time instability can be prevented in several ways. First, carefully follow the recommended layout techniques. Second, use 2 μ F or more of X5R or X7R ceramic input capacitance per Amp of load current. Third, if necessary, increase the bottom MOSFET ripple voltage to 30mV_{P-P} or greater. This ripple voltage is equal to $R_{DS(ON)}$ typical at 25°C • I_{P-P} .

Design Example

Figure 10 is a power supply design example with the following specifications: $V_{IN} = 4.5V$ to 28V (12V nominal), $V_{OUT} = 1.2V \pm 5\%$, $I_{OUT(MAX)} = 15A$ and $f = 400kHz$. Start by calculating the timing resistor, R_{ON} :

$$R_{ON} = \frac{1.2V}{0.7V \cdot 400kHz \cdot 10pF} = 429k$$

Select the nearest standard resistor value of 432k for a nominal operating frequency of 396kHz. Set the inductor value to give 35% ripple current at maximum V_{IN} using the adjusted operating frequency:

$$L = \frac{1.2V}{396kHz \cdot 0.35 \cdot 15A} \left(1 - \frac{1.2}{28} \right) = 0.55\mu H$$

Select 0.56 μ H which is the nearest value.

The resulting maximum ripple current is:

$$\Delta I_L = \frac{1.2V}{396kHz \cdot 0.56\mu H} \left(1 - \frac{1.2V}{28V} \right) = 5.1A$$

Choose the synchronous bottom MOSFET switch and calculate the V_{RNG} current limit set-point. To calculate V_{RNG} and V_{DS} , the $\rho\tau$ term normalization factor (unity

APPLICATIONS INFORMATION

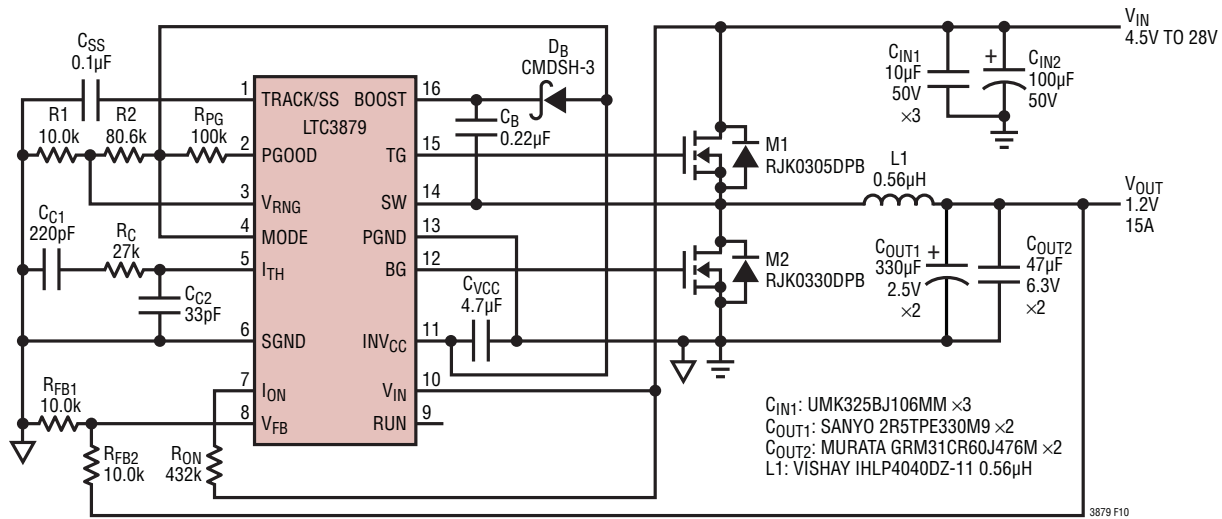

Figure 10. Design Example: 1.2V/15A at 400kHz

at 25°C) is required to account for variation in MOSFET on-resistance with temperature. Choosing an RJK0330 ($R_{DS(ON)} = 2.8\text{m}\Omega$ (nominal) $3.9\text{m}\Omega$ (maximum), $V_{GS} = 4.5\text{V}$, $\theta_{JA} = 40^\circ\text{C/W}$) yields a drain source voltage of:

$$V_{DS} = \left(I_{LIMIT} - \frac{1}{2} (I_{RIPPLE}) \right) 3.9\text{m}\Omega (\rho\tau)$$

V_{RNG} sets current limit by fixing the maximum peak V_{DS} voltage on the bottom MOSFET switch. As a result, the average DC current limit includes significant temperature and component variability. Design to guarantee that the average DC current limit will always exceed the rated operating output current by assuming worst-case component tolerance and temperature.

The worst-case minimum $INTV_{CC}$ is 5.15V. The bottom MOSFET worst-case $R_{DS(ON)}$ is $3.9\text{m}\Omega$ and the junction temperature is 80°C above a 70°C ambient with $\rho_{150^\circ\text{C}} = 1.5$. Set T_{ON} equal to the minimum specification of 15% low and the inductor 15% high.

By setting I_{LIMIT} equal to 15A we get 79mV for peak V_{DS} voltage which corresponds to a V_{RNG} equal to 592mV:

$$V_{DS} = \left(15\text{A} - \frac{1}{2} \cdot 5.1\text{A} \cdot \frac{0.85}{1.15} \right) \frac{3.9\text{m}\Omega}{5.15\text{V}} \cdot 1.5$$

$$V_{RNG} = 7.5 \cdot V_{DS}$$

Verify that the calculated nominal T_J is less than the assumed worst-case T_J in the bottom MOSFET:

$$P_{BOT} = \frac{28\text{V} - 1.2\text{V}}{28\text{V}} (15\text{A})^2 \cdot 1.5 \cdot 3.9\text{m}\Omega = 1.25\text{W}$$

$$T_J = 70^\circ\text{C} + 1.25\text{W} \cdot 40^\circ\text{C/W} = 120^\circ\text{C}$$

Because the top MOSFET is on for a short time, an RJK0305DPB ($R_{DS(ON)} = 10\text{m}\Omega$ (nominal) $13\text{m}\Omega$ (maximum), $C_{MILLER} = Q_{GD}/10\text{V} = 150\text{pF}$, $V_{BOOST} = 5\text{V}$, $V_{GS} = 4.5\text{V}$, $V_{MILLER} = 3\text{V}$, $\theta_{JA} = 40^\circ\text{C/W}$) is sufficient. Checking its power dissipation at current limit with $\rho_{100^\circ\text{C}} = 1.4$:

$$P_{TOP} = \frac{1.2\text{V}}{28\text{V}} (15\text{A})^2 \cdot 1.4 \cdot 13\text{m}\Omega + (28\text{V})^2 \left(\frac{15\text{A}}{2} \right)$$

$$(150\text{pF}) \left(\frac{2.5\Omega}{5\text{V} - 3\text{V}} + \frac{1.2\Omega}{3\text{V}} \right) 400\text{kHz}$$

$$= 0.18\text{W} + 0.58\text{W} = 0.76\text{W}$$

$$T_J = 70^\circ\text{C} + 0.76\text{W} \cdot 40^\circ\text{C/W} = 100^\circ\text{C}$$

The junction temperatures will be significantly less at nominal current, but this analysis shows that careful attention to heat sinking will be necessary.

Select C_{IN} to give an RMS current rating greater than 4A at 85°C . The output capacitor C_{OUT1} is chosen for a low ESR of $4.5\text{m}\Omega$ to minimize output voltage changes due to

APPLICATIONS INFORMATION

inductor ripple current and load steps. The output voltage ripple is given as:

$$\begin{aligned}\Delta V_{\text{OUT(RIPPLE)}} &= \Delta I_{\text{L(MAX)}} (\text{ESR}) \\ &= 5.1 \cdot 4.5\text{m}\Omega = 23\text{mV}\end{aligned}$$

However, a 0A to 10A load step will cause an output change of up to:

$$\begin{aligned}\Delta V_{\text{OUT(STEP)}} &= \Delta I_{\text{LOAD}} (\text{ESR}) \\ &= 10\text{A} \cdot 4.5\text{m}\Omega = 45\text{mV}\end{aligned}$$

Optional $2 \times 47\mu\text{F}$ ceramic output capacitors are included to minimize the effect of ESR and ESL in the output ripple and to improve load step response.

PC Board Layout Checklist

The LTC3879 PC board layout can be designed with or without a ground plane. A ground plane is generally preferred based on performance and noise concerns.

When using a ground plane, use a dedicated ground plane layer. In addition, for high current it is recommended to use a multilayer board to help with heat sinking power components.

- The ground plane layer should have no traces and be as close as possible to the routing layer connecting the power MOSFETs.
- Place LTC3879 Pins 9 to 16 facing the power components. Keep components connected to Pin 1 close to LTC3879 (noise sensitive components).
- Place C_{IN} , C_{OUT} , MOSFETs, D_{B} and inductor all in one compact area. It may help to have some components on the bottom side of the board.
- Use an immediate via to connect components to the ground plane SGND and PGND of LTC3879. Use several larger vias for power components.
- Use compact switch node (SW) plane to improve cooling of the MOSFETs and to keep EMI down.
- Use planes for V_{IN} and V_{OUT} to maintain good voltage filtering and to keep power losses low.
- Flood all unused areas on all layers with copper. Flooding with copper will reduce the temperature rise of power component. You can connect the copper areas to any DC net. (V_{IN} , V_{OUT} , GND or to any other DC rail in your system).
- Place decoupling capacitor C_{C2} next to the I_{TH} and SGND pins with short, direct trace connections.

When laying out a printed circuit board without a ground plane, use the following checklist to ensure proper operation of the controller. These items are illustrated in Figure 11.

- Segregate the signal and power grounds. All small-signal components should return to the SGND pin at one point. SGND and PGND should be tied together underneath the IC and then connect directly to the source of M2.
- Place M2 as close to the controller as possible, keeping the PGND, BG and SW traces short.
- Keep the high dV/dt SW, BOOST and TG nodes away from sensitive small-signal nodes.
- Connect the input capacitor(s), C_{IN} , close to the power MOSFETs. This capacitor carries the MOSFET AC current.
- Connect the INTV_{CC} decoupling capacitor C_{VCC} closely to the INTV_{CC} and PGND pins.
- Connect the top driver boost capacitor, C_{B} , closely to the BOOST and SW pins.
- Connect the V_{IN} pin decoupling C_{F} closely to the V_{IN} and PGND pins.

APPLICATIONS INFORMATION

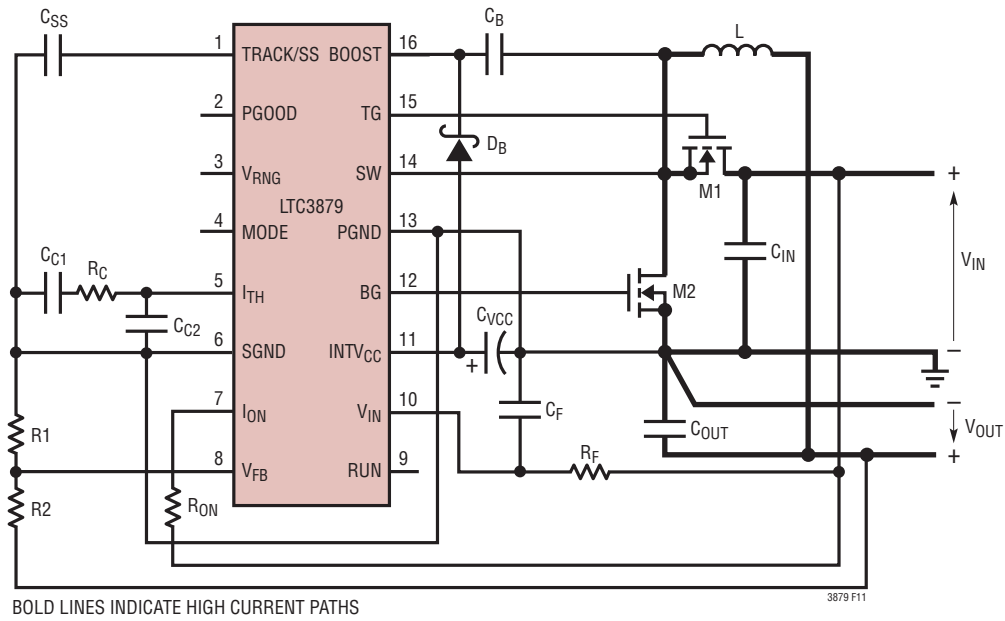
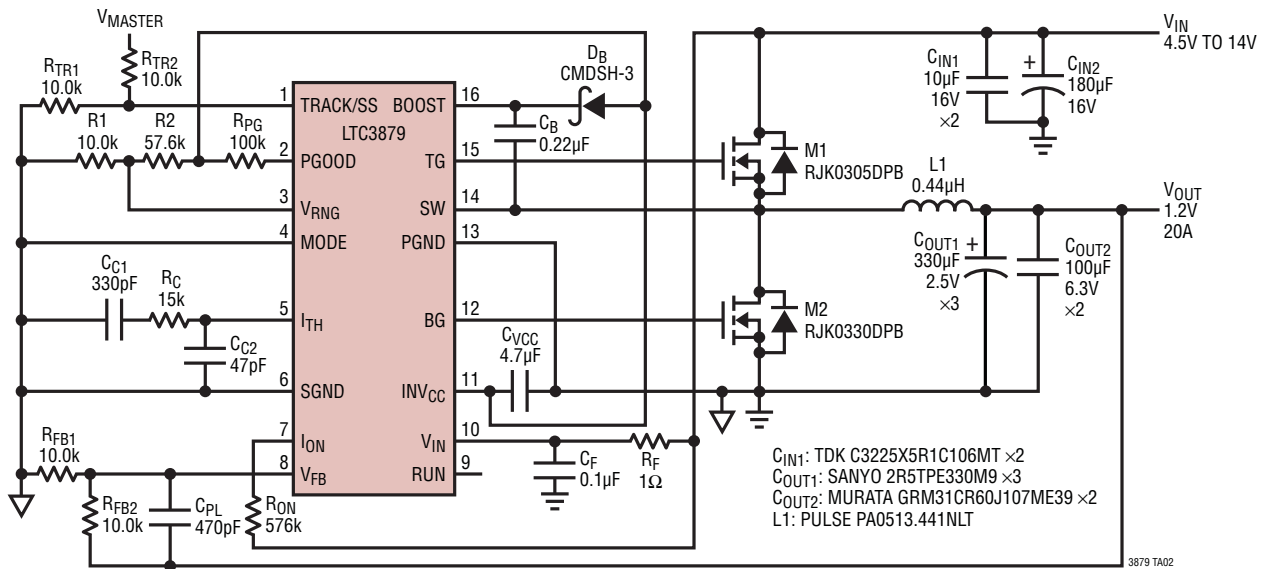

Figure 11. LTC3879 Layout Diagram Without Ground Plane

TYPICAL APPLICATIONS

4.5V to 14V Input, 1.2V/20A Output at 300kHz with Coincident Rail Tracking



TYPICAL APPLICATIONS

4.5V to 24V Input, 1.8V/10A Output at 500kHz

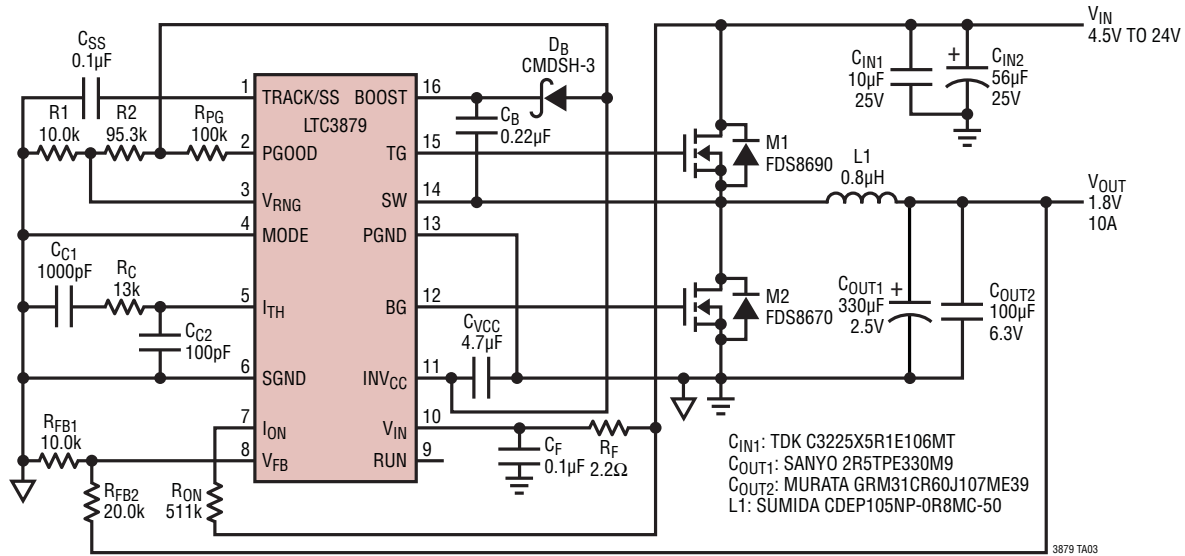

4.5V to 32V Input, 1V/5A Output at 250kHz

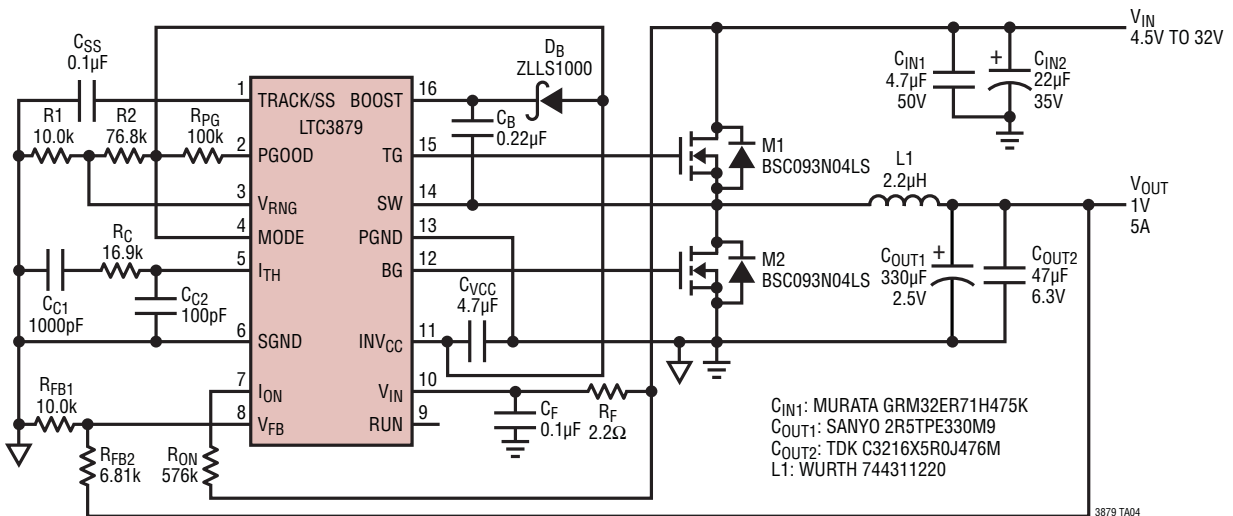

TYPICAL APPLICATIONS

4.5V to 28V Input, 2.5V/5A Output at 500kHz

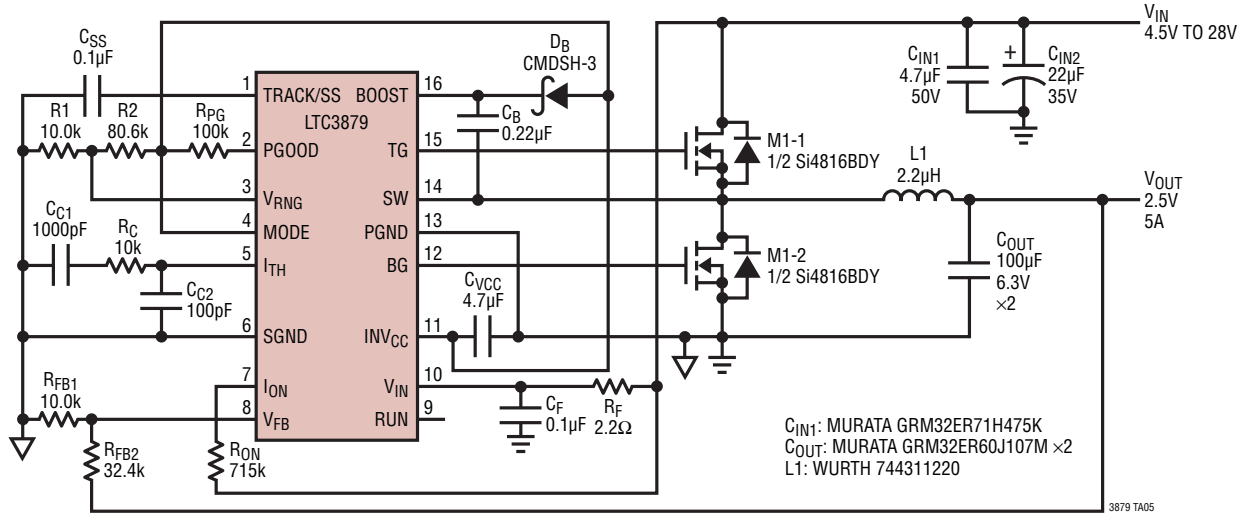

13V to 32V Input, 12V/5A Output at 300kHz

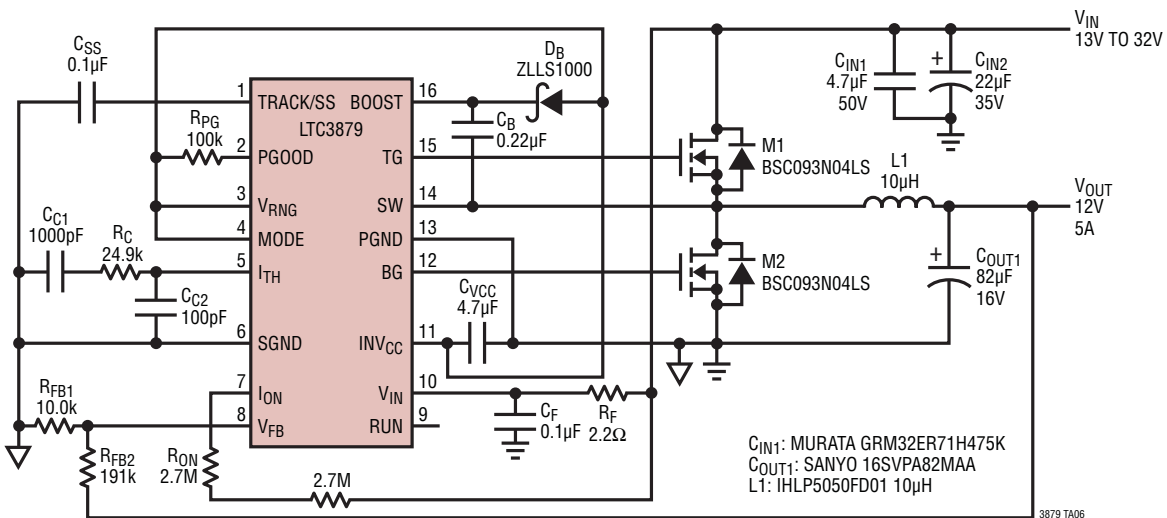

TYPICAL APPLICATIONS

Positive-to-Negative Converter, -5V at 300kHz

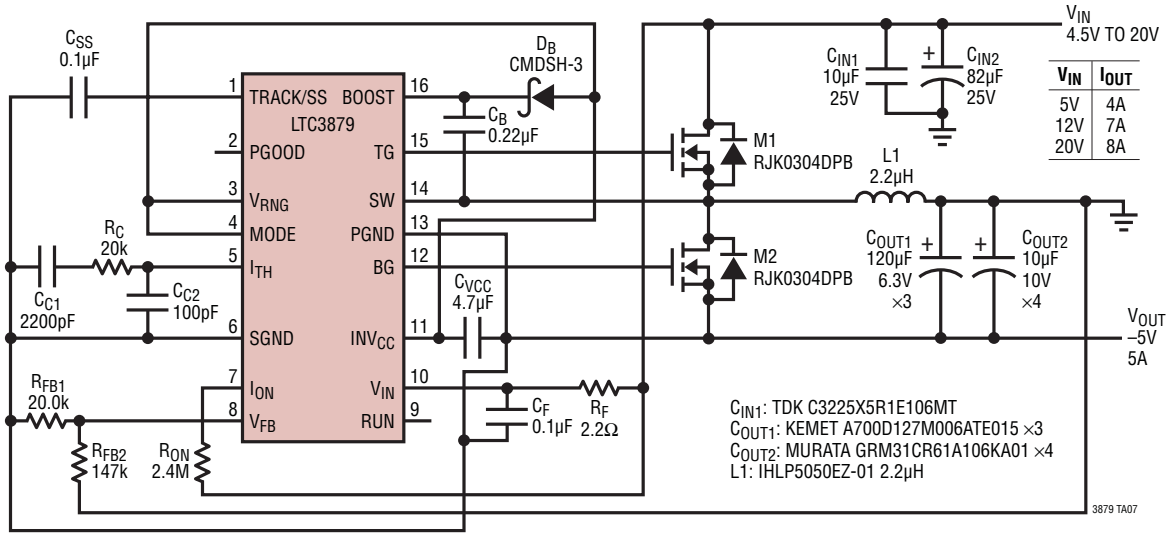

3879 TA07

PACKAGE DESCRIPTION

MSE Package 16-Lead Plastic MSOP, Exposed Die Pad (Reference LTC DWG # 05-08-1667 Rev A)

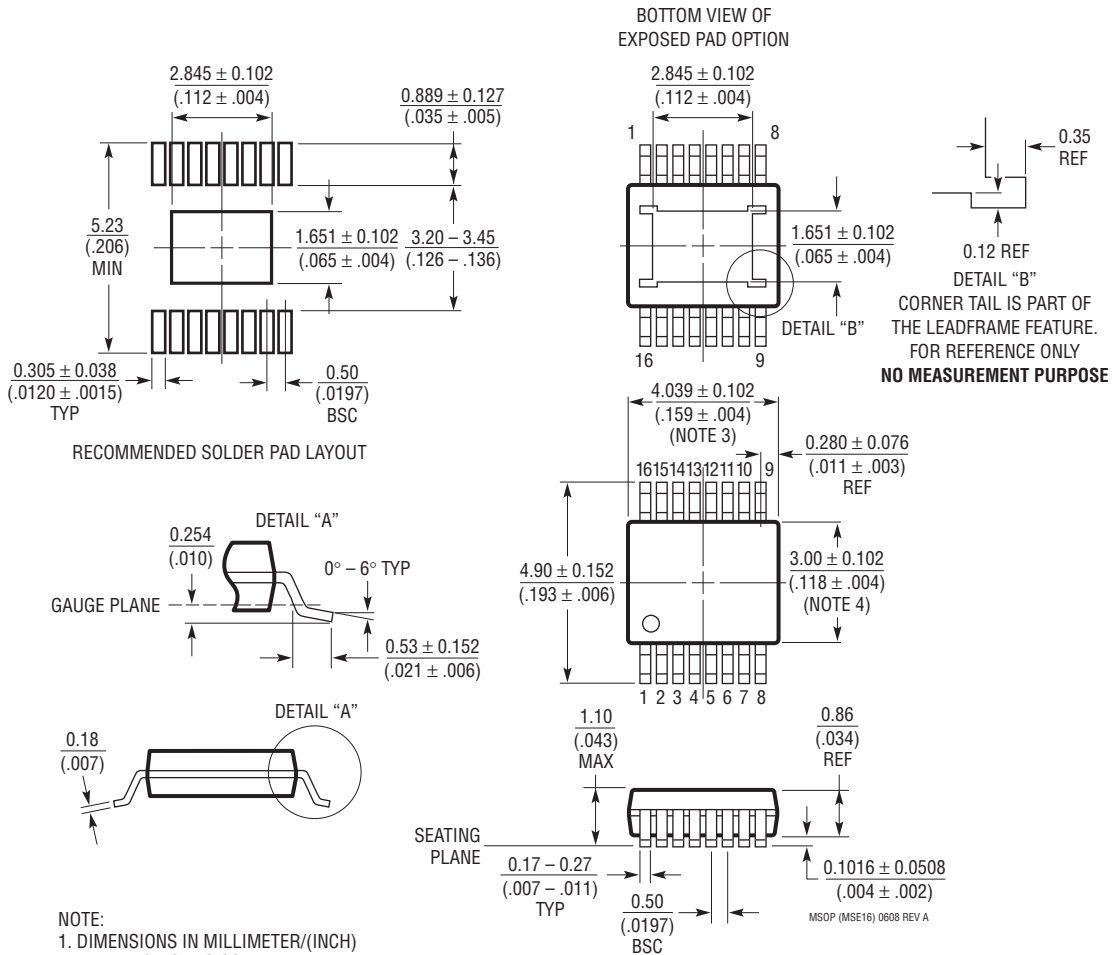

NOTE:

1. DIMENSIONS IN MILLIMETER/(INCH)
2. DRAWING NOT TO SCALE
3. DIMENSION DOES NOT INCLUDE MOLD FLASH, PROTRUSIONS OR GATE BURRS.
MOLD FLASH, PROTRUSIONS OR GATE BURRS SHALL NOT EXCEED 0.152mm (.006") PER SIDE
4. DIMENSION DOES NOT INCLUDE INTERLEAD FLASH OR PROTRUSIONS.
INTERLEAD FLASH OR PROTRUSIONS SHALL NOT EXCEED 0.152mm (.006") PER SIDE
5. LEAD COPLANARITY (BOTTOM OF LEADS AFTER FORMING) SHALL BE 0.102mm (.004") MAX

RELATED PARTS

PART NUMBER	DESCRIPTION	COMMENTS
LTC3608/LTC3609	8A/6A Monolithic Synchronous Step-Down DC/DC Converters	Optimized for High Step-Down Ratios, V_{IN} Up to 18V/32V
LTC3610/LTC3611	12A/10A Monolithic Synchronous Step-Down DC/DC Converters	Optimized for High Step-Down Ratios, V_{IN} Up to 24V/32V
LTC3728	2-Phase 550kHz, Dual Synchronous Step-Down Controller	QFN and SSOP Packages
LTC3770	No R_{SENSE} Synchronous Step-Down Controller with Voltage Margining, PLL and Tracking	$0.6V \leq V_{OUT} \leq (0.9)V_{IN}$, $4V \leq V_{IN} \leq 36V$, I_{OUT} Up to 20A
LTC3778	No R_{SENSE} Constant On-Time Synchronous Step-Down Controller	Extremely Fast Transient Response, $t_{ON(MIN)} \leq 100ns$, $4V \leq V_{IN} \leq 36V$, 0.8V Reference
LTC3811	Dual, PolyPhase [®] Synchronous Step-Down Controller, 20A to 200A	Differential Remote Sense Amplifier, R_{SENSE} or DCR Current Sense
LTC3823	Constant On-Time Synchronous No R_{SENSE} Step-Down Controller with Differential Output Sensing	Fast Transient Response, $4.5V \leq V_{IN} \leq 36V$, $0.6V \leq V_{OUT} \leq 0.9V_{IN}$, Tracking and PLL Synchronization
LTC3824	Low I_Q , High Voltage Current Mode Controller, 100% Duty Cycle, Programmable Operating Frequency	V_{IN} Up to 60V, $I_{OUT} \leq 5A$, Onboard Bias Regulator, Burst Mode Operation, 40 μ A I_Q , MSOP-10 Package
LTC3826/LTC3826-1	Very Low I_Q , Dual, 2-Phase Synchronous Step-Down Controllers	30 μ A I_Q , $0.8V \leq V_{OUT} \leq 10V$, $4V \leq V_{IN} \leq 36V$
LTC3834/LTC3834-1	Very Low I_Q , Synchronous Step-Down Controller	30 μ A I_Q , $0.8V \leq V_{OUT} \leq 10V$, $4V \leq V_{IN} \leq 36V$
LT3844	Low I_Q , High Voltage Current Mode Controller with Programmable Operating Frequency	V_{IN} Up to 60V, $I_{OUT} \leq 5V$ Onboard Bias Regulator, Burst Mode Operation, 120 μ A I_Q , Sync Capability, 16-Lead TSSOP Package
LT3845	Low I_Q , High Voltage Single Output Synchronous Step-Down DC/DC Controller	$1.23V \leq V_{OUT} \leq 36V$, $4V \leq V_{IN} \leq 60V$, 120 μ A I_Q
LTC3850/LTC3850-1 LTC3850-2	Dual 2-Phase, High Efficiency Synchronous Step-Down Controllers	R_{SENSE} or DCR Current Sense, 250kHz to 780kHz Fixed Operating Frequency, $4V \leq V_{IN} \leq 30V$, $0.8V \leq V_{OUT} \leq 5.25V$
LTC3851/LTC3851-1	No R_{SENSE} Wide Input Range Step-Down Controllers	$4V \leq V_{IN} \leq 38V$, Very Low Dropout with Tracking, DCR Current Sense, MSOP-16, SSOP-16, 3mm \times 3mm QFN-16
LTC3853	Triple Output, Multiphase Synchronous Step-Down Controller	R_{SENSE} or DCR Current Sensing, Tracking and Synchronizable
LTC3878	No R_{SENSE} Constant On-Time Synchronous Step-Down Controller	Extremely Fast Transient Response, $t_{ON(MIN)} = 43ns$, $4V \leq V_{IN} \leq 38V$, 0.8V Reference
LTM4600HV	10A Complete Switch Mode Power Supply	92% Efficiency, V_{IN} : 4.5V to 28V, True Current Mode Control, Ultrafast [™] Transient Response
LTM4601AHV	12A Complete Switch Mode Power Supply	92% Efficiency, V_{IN} : 4.5V to 28V, True Current Mode Control, Ultrafast Transient Response

PolyPhase is a registered trademark fo Linear Technology Corporation. No R_{SENSE} is a trademark of Linear Technology Corporation.

Looking for pricing, stock, or lifecycle information?

Click below to explore more details on WIN SOURCE:

 [View LTC3879IMSE#PBF on WIN SOURCE](#)

 [Analog Devices Inc. Information](#)

Optimize Your Supply Chain with WIN SOURCE Solutions

-  Global Sourcing Solution
-  Obsolete Management
-  Cost Control Management
-  Shortage Management
-  Alternative Solution
-  Excess Inventory Management